



**THE DATASHEET OF
MAX4781EGE+T**





High-Speed, Low-Voltage, 0.7Ω CMOS Analog Switches/Multiplexers

MAX4781/MAX4782/MAX4783

General Description

The MAX4781/MAX4782/MAX4783 are high-speed, low-voltage, low on-resistance, CMOS analog multiplexers/switches configured as an 8-channel multiplexer (MAX4781), two 4-channel multiplexers (MAX4782), and three single-pole/double-throw (SPDT) switches (MAX4783).

These devices operate with a +1.6V to +3.6V single supply. When powered from a +3V supply, MAX4781/MAX4782/MAX4783 feature a 0.7Ω on-resistance (RON), with 0.3Ω RON matching between channels, and 0.1Ω RON flatness. These devices handle rail-to-rail analog signals while consuming less than 3μW of quiescent power. They are available in space-saving 16-pin thin QFN (3mm x 3mm) and TSSOP packages.

Applications

- Battery-Operated Equipment
- Audio Signal Routing
- Low-Voltage Data-Acquisition Systems
- Communications Circuits

Features

- ◆ On-Resistance
0.7Ω (+3V Supply)
1.6Ω (+1.8V Supply)
- ◆ On-Resistance Match Between Channels
0.3Ω (+3V Supply)
- ◆ On-Resistance Flatness
0.1Ω (+3V Supply)
- ◆ Single-Supply Operation Down to 1.6V
- ◆ High-Current Handling Capacity (150mA Continuous)
- ◆ +1.8V CMOS-Logic Compatible
- ◆ Fast Switching Times: tON = 11ns, tOFF = 4ns
- ◆ Pin Compatible with Industry-Standard 74HC4051/74HC4052/74HC4053 and MAX4617/MAX4618/MAX4619
- ◆ Available in 3mm x 3mm 16-Pin Thin QFN Packages

Ordering Information

PART	TEMP RANGE	PIN-PACKAGE
MAX4781EUE	-40°C to +85°C	16 TSSOP
MAX4781ETE	-40°C to +85°C	16 Thin QFN (3mm x 3mm)
MAX4782EUE	-40°C to +85°C	16 TSSOP
MAX4782ETE	-40°C to +85°C	16 Thin QFN (3mm x 3mm)
MAX4783EUE	-40°C to +85°C	16 TSSOP
MAX4783ETE	-40°C to +85°C	16 Thin QFN (3mm x 3mm)

Pin Configurations/Functional Diagrams

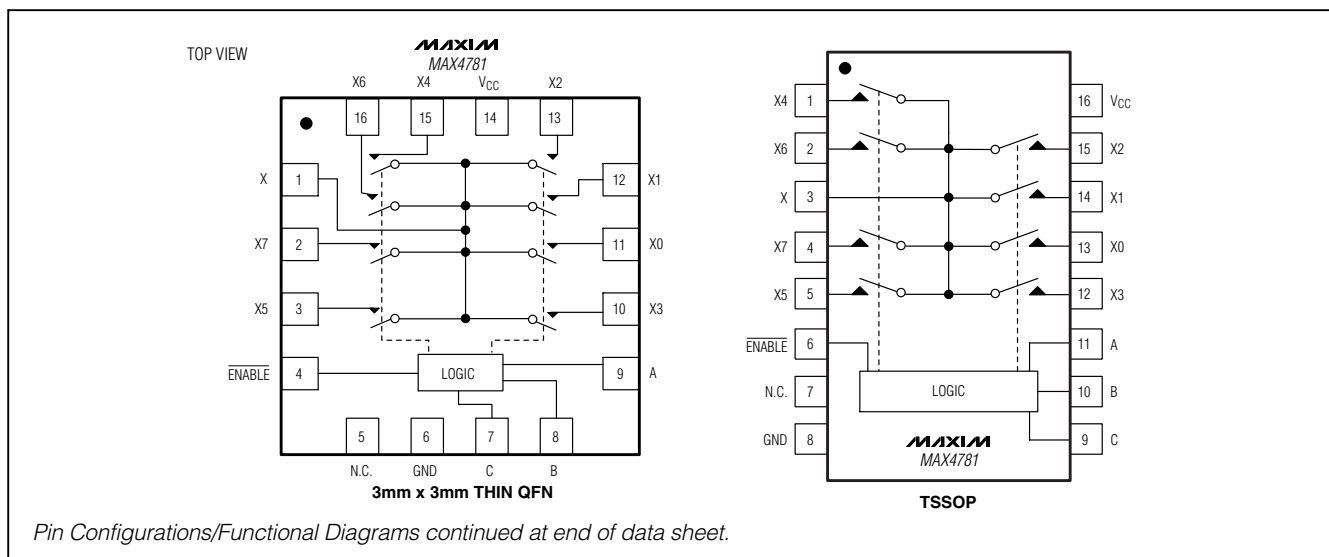

High-Speed, Low-Voltage, 0.7Ω CMOS Analog Switches/Multiplexers

ABSOLUTE MAXIMUM RATINGS

Voltages Referenced to GND

V_{CC} , A, B, C, and \overline{ENABLE} -0.3V to +4.6V

Voltage at Any Other Terminal

(Note 1).....-0.3V to ($V_{CC} + 0.3V$)

Continuous Current into A, B, C, \overline{ENABLE} $\pm 10mA$

Continuous Current into X, Y, Z, X_{-} , Y_{-} , Z_{-} $\pm 150mA$

Peak Current into X, Y, Z, X_{-} , Y_{-} , Z_{-}

(pulsed at 1ms, 10% duty cycle)..... $\pm 300mA$

Continuous Power Dissipation

16-Pin Thin QFN (derate 16.9mW/°C above +70°C) ...1349mW

16-Pin TSSOP (derate 5.7mW/°C above +70°C) 457mW

Operating Temperature Range-40°C to +85°C

Junction Temperature+150°C

Storage Temperature Range-65°C to +150°C

Lead Temperature (soldering, 10s)+300°C

Note 1: Signals on X, Y, Z, X_{-} , Y_{-} , and Z_{-} exceeding V_{CC} or GND are clamped by internal diodes. Limit forward-diode current to maximum current rating.

Stresses beyond those listed under "Absolute Maximum Ratings" may cause permanent damage to the device. These are stress ratings only, and functional operation of the device at these or any other conditions beyond those indicated in the operational sections of the specifications is not implied. Exposure to absolute maximum rating conditions for extended periods may affect device reliability.

ELECTRICAL CHARACTERISTICS—Single +3V Supply

($V_{CC} = +2.7V$ to +3.6V, GND = 0, $V_{IH} = 1.4V$, $V_{IL} = 0.5V$, $T_A = T_{MIN}$ to T_{MAX} , unless otherwise noted. Typical values are at $T_A = +25^{\circ}C$.) (Notes 2, 3)

PARAMETER	SYMBOL	CONDITIONS	T_A	MIN	TYP	MAX	UNITS
ANALOG SWITCH							
Analog Signal Range	$V_X, V_Y, V_Z,$ V_{X-}, V_{Y-}, V_{Z-}			0		V_{CC}	V
On-Resistance (Note 4)	R_{ON}	$V_{CC} = +2.7V; I_{X-}, I_{Y-}, I_{Z-} = 100mA; V_X, V_Y, V_Z = 1.7V$	+25°C	0.7	1		Ω
			T_{MIN} to T_{MAX}			1.2	
On-Resistance Match Between Channels (Notes 4, 5)	ΔR_{ON}	$V_{CC} = +2.7V; I_{X-}, I_{Y-}, I_{Z-} = 100mA; V_X, V_Y, V_Z = 1.7V$	+25°C	0.3	0.4		Ω
			T_{MIN} to T_{MAX}			0.6	
On-Resistance Flatness (Note 6)	$R_{FLAT(ON)}$	$V_{CC} = +2.7V; I_{X-}, I_{Y-}, I_{Z-} = 100mA; V_X, V_Y, V_Z = 0, 0.7V, 1.7V$	+25°C	0.1	0.2		Ω
			T_{MIN} to T_{MAX}			0.2	
X_{-}, Y_{-}, Z_{-} Off-Leakage Current	$I_{X(OFF)}$ $I_{Y(OFF)}$ $I_{Z(OFF)}$	$V_{CC} = +3.6V;$ $V_{X-}, V_{Y-}, V_{Z-} = 3.3V, 0.3V; V_X,$ $V_Y, V_Z = 0.3V, 3.3V$	+25°C	-2	0.002	+2	nA
			T_{MIN} to T_{MAX}	-7		+7	
X Off-Leakage Current (MAX4781 Only)	$I_{X(OFF)}$	$V_{CC} = +3.6V;$ $V_{X-} = 3.3V, 0.3V;$ $V_{X-} = 0.3V, 3.3V$	+25°C	-2	0.002	+2	nA
			T_{MIN} to T_{MAX}	-50		+50	
X On-Leakage Current (MAX4781 Only)	$I_{X(ON)}$	$V_{CC} = +3.6V$ $V_{X-} = 0.3V, 3.3V;$ $V_{X-} = 0.3V, 3.3V$ or floating	+25°C	-2	0.002	+2	nA
			T_{MIN} to T_{MAX}	-50		+50	
X, Y, Z Off-Leakage Current (MAX4782/MAX4783 Only)	$I_{X(OFF)}$ $I_{Y(OFF)}$ $I_{Z(OFF)}$	$V_{CC} = +3.6V;$ $V_{X-}, V_{Y-}, V_{Z-} = 3.3V, 0.3V; V_X,$ $V_Y, V_Z = 0.3V, 3.3V$	+25°C	-2	0.002	+2	nA
			T_{MIN} to T_{MAX}	-25		+25	
X, Y, Z On-Leakage Current (MAX4782/MAX4783 Only)	$I_{X(ON)}$ $I_{Y(ON)}$ $I_{Z(ON)}$	$V_{CC} = +3.6V;$ $V_X, V_Y, V_Z = 0.3V, 3.3V; V_X, V_Y,$ $V_Z = 0.3V, 3.3V$ or floating	+25°C	-2	0.002	+2	nA
			T_{MIN} to T_{MAX}	-25		+25	

High-Speed, Low-Voltage, 0.7Ω CMOS Analog Switches/Multiplexers

MAX4781/MAX4782/MAX4783

ELECTRICAL CHARACTERISTICS—Single +3V Supply (continued)

(V_{CC} = +2.7V to +3.6V, GND = 0, V_{IH} = 1.4V, V_{IL} = 0.5V, T_A = T_{MIN} to T_{MAX}, unless otherwise noted. Typical values are at T_A = +25°C.) (Notes 2, 3)

PARAMETER	SYMBOL	CONDITIONS	T _A	MIN	TYP	MAX	UNITS
SWITCH DYNAMIC CHARACTERISTICS							
Turn-On Time	t _{ON}	V _X , V _Y , V _Z = 1.5V; R _L = 50Ω; C _L = 35pF; Figure 1	+25°C	11	25	ns	
			T _{MIN} to T _{MAX}	27			
Turn-Off Time	t _{OFF}	V _X , V _Y , V _Z = 1.5V; R _L = 50Ω; C _L = 35pF; Figure 1	+25°C	4	15	ns	
			T _{MIN} to T _{MAX}	20			
Address Transition Time	t _{TRANS}	V _X , V _Y , V _Z = 1.5V; R _L = 50Ω; C _L = 35pF; Figure 2	+25°C	11	25	ns	
			T _{MIN} to T _{MAX}	27			
Break-Before-Make Time (Note 7)	t _{BBM}	V _X , V _Y , V _Z = 1.5V; R _L = 50Ω; C _L = 35pF; Figure 3	+25°C	18		ns	
			T _{MIN} to T _{MAX}	2			
Charge Injection	Q	V _{GEN} = 0, R _{GEN} = 0, C _L = 1nF, Figure 4	+25°C	-110		pC	
Input Off-Capacitance	C _{X(OFF)} , C _{Y(OFF)} , C _{Z(OFF)}	f = 1MHz, Figure 6	+25°C	38		pF	
Output Off-Capacitance	C _{X(OFF)} , C _{Y(OFF)} , C _{Z(OFF)}	f = 1MHz, Figure 6	+25°C	MAX4781	310		pF
				MAX4782	158		
				MAX4783	75		
Output On-Capacitance	C _{X(ON)} , C _{Y(ON)} , C _{Z(ON)}	f = 1MHz, Figure 6	+25°C	MAX4781	380		pF
				MAX4782	224		
				MAX4783	140		
Off-Isolation (Note 8)	V _{ISO}	R _L = 50Ω, C _L = 35pF, Figure 5	f = 10MHz	-75		dB	
			f = 1MHz	-90			
Channel-to-Channel Crosstalk (Note 9)	V _{CT}	R _L = 50Ω, C _L = 35pF, Figure 5	f = 10MHz	-65		dB	
			f = 1MHz	-80			
Total Harmonic Distortion	THD	f = 20Hz to 20kHz, 0.5V _{p-p} , R _L = 32Ω		0.045		%	
DIGITAL I/O							
Input Logic High	V _{IH}		T _{MIN} to T _{MAX}	1.4		V	
Input Logic Low	V _{IL}		T _{MIN} to T _{MAX}	0.5		V	
Input Leakage Current	I _{INL}	V _A , V _B , V _C = V _{ENABLE} = 0 or 3.6V	T _{MIN} to T _{MAX}	-1	0.0005	+1	μA
POWER SUPPLY							
Power-Supply Range	V _{CC}			+1.6	+3.6		V
Positive Supply Current	I _{CC}	V _{CC} = 3.6V; V _A , V _B , V _C ; V _{ENABLE} = 3.6V or 0		1		μA	

High-Speed, Low-Voltage, 0.7Ω CMOS Analog Switches/Multiplexers

ELECTRICAL CHARACTERISTICS—Single +1.8V Supply

($V_{CC} = +1.8V$, $GND = 0$, $V_{IH} = 1V$, $V_{IL} = 0.4V$, $T_A = T_{MIN}$ to T_{MAX} , unless otherwise noted. Typical values are at $T_A = +25^\circ C$.) (Notes 2, 3)

PARAMETER	SYMBOL	CONDITIONS	T_A	MIN	TYP	MAX	UNITS
ANALOG SWITCH							
Analog Signal Range	$V_{X-}, V_{Y-}, V_{Z-}, V_X, V_Y, V_Z$			0		V_{CC}	V
On-Resistance (Note 4)	R_{ON}	$V_{CC} = 1.8V; I_{X-}, I_{Y-}, I_{Z-} = 10mA; V_X, V_Y, V_Z = 1.0V$	$+25^\circ C$	1.6	2.5		Ω
			T_{MIN} to T_{MAX}		3.5		
On-Resistance Match Between Channels (Notes 4, 5)	ΔR_{ON}	$V_{CC} = 1.8V; I_{X-}, I_{Y-}, I_{Z-} = 10mA; V_X, V_Y, V_Z = 1.0V$	$+25^\circ C$	0.3	0.4		Ω
			T_{MIN} to T_{MAX}		0.6		
SWITCH DYNAMIC CHARACTERISTICS							
Turn-On Time	t_{ON}	$V_{X-}, V_{Y-}, V_{Z-} = 1.0V; R_L = 50\Omega; C_L = 35pF$; Figure 1	$+25^\circ C$	17	30		ns
			T_{MIN} to T_{MAX}		32		
Turn-Off Time	t_{OFF}	$V_{X-}, V_{Y-}, V_{Z-} = 1.0V; R_L = 50\Omega; C_L = 35pF$; Figure 1	$+25^\circ C$	8	20		ns
			T_{MIN} to T_{MAX}		22		
Address Transition Time	t_{TRANS}	$V_{X-}, V_{Y-}, V_{Z-} = 1.0V; R_L = 50\Omega; C_L = 35pF$; Figure 2	$+25^\circ C$	17	30		ns
			T_{MIN} to T_{MAX}		32		
Break-Before-Make Time (Note 7)	t_{BBM}	$V_{X-}, V_{Y-}, V_{Z-} = 1V; R_L = 50\Omega; C_L = 35pF$; Figure 3	$+25^\circ C$	26			ns
			T_{MIN} to T_{MAX}	1			
Charge Injection	Q	$V_{GEN} = 0, R_{GEN} = 0, C_L = 1nF$, Figure 4	$+25^\circ C$	-40			pC
DIGITAL I/O							
Input Logic High	V_{IH}		T_{MIN} to T_{MAX}	1			V
Input Logic Low	V_{IL}		T_{MIN} to T_{MAX}			0.4	V
Input Leakage Current	I_{IN-}	$V_A, V_B, V_C = V_{ENABLE} = 0$ or $3.6V$	T_{MIN} to T_{MAX}	-1	0.000	+1	μA
POWER SUPPLY							
Power-Supply Range	V_{CC}			1.6		3.6	V
Positive Supply Current	I_{CC}	$V_{CC} = 3.6V; V_A, V_B, V_C, V_{ENABLE} = 0$ or $3.6V$				1	μA

Note 2: The algebraic convention is used in this data sheet; the most negative value is shown in the minimum column.

Note 3: Devices are tested at maximum hot temperature and are guaranteed by design and correlation at $T_A = +25^\circ C$ and $-40^\circ C$ specifications.

Note 4: R_{ON} and ΔR_{ON} matching specifications for thin QFN-packaged parts are guaranteed by design.

Note 5: $\Delta R_{ON} = R_{ON(MAX)} - R_{ON(MIN)}$.

Note 6: Flatness is defined as the difference between the maximum and minimum value of on-resistance as measured over the specified analog signal ranges.

Note 7: Guaranteed by design; not production tested.

Note 8: Off-isolation = $20\log_{10}(V_{COM-} / V_{NO})$, V_{COM-} = output, V_{NO} = input to off switch.

Note 9: Between any two channels.

High-Speed, Low-Voltage, 0.7Ω CMOS Analog Switches/Multiplexers

Typical Operating Characteristics

(GND = 0, $T_A = +25^\circ\text{C}$, unless otherwise noted.)

MAX4781/MAX4782/MAX4783

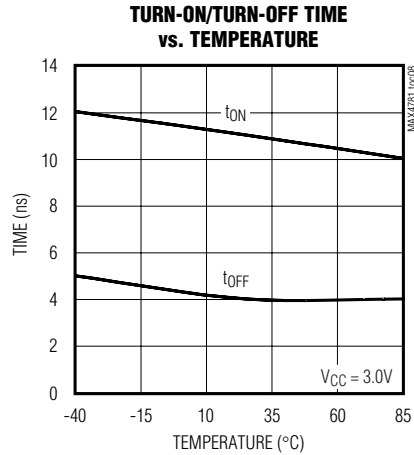
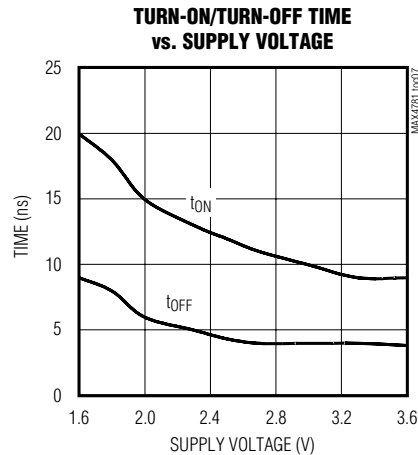
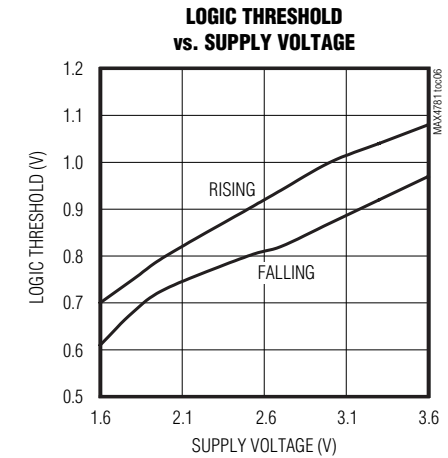
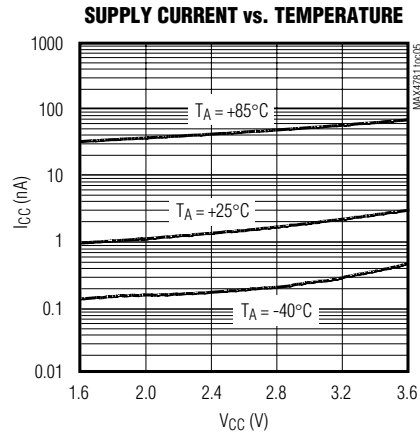
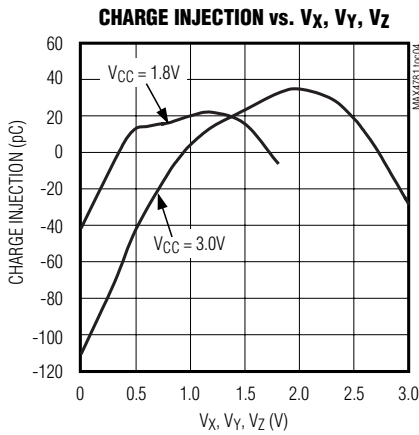
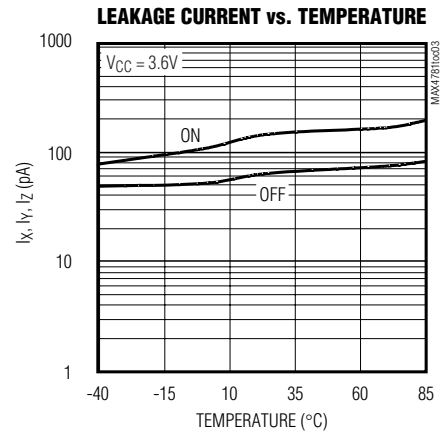
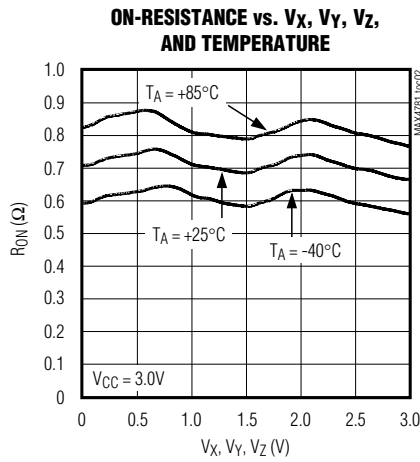
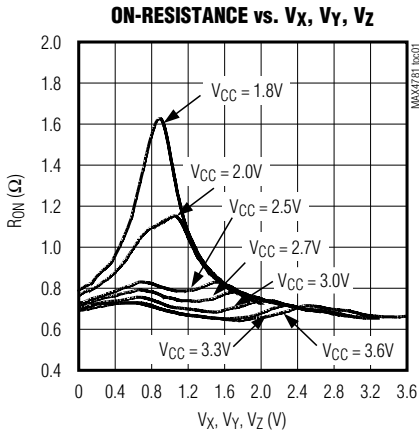

High-Speed, Low-Voltage, 0.7Ω CMOS Analog Switches/Multiplexers

Typical Operating Characteristics (continued)

(GND = 0, T_A = +25°C, unless otherwise noted.)

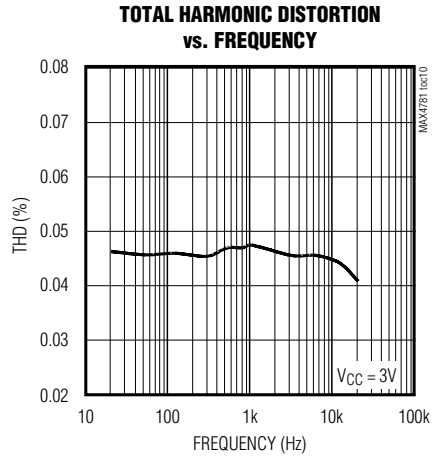
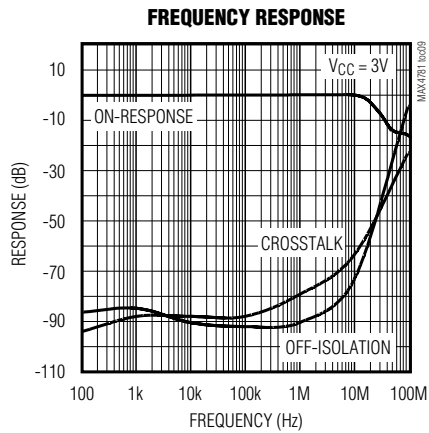

MAX4781 Pin Description

PIN		NAME	FUNCTION
TSSOP	THIN QFN		
3	1	X	Analog Switch Output
6	4	$\overline{\text{ENABLE}}$	Digital Enable Input. Normally connect to GND. Drive to logic high to set all switches off.
7	5	N.C.	No Connection. Not internally connected.
8	6	GND	Ground
9	7	C	Digital Address C Input
10	8	B	Digital Address B Input
11	9	A	Digital Address A Input
13, 14, 15, 12, 1, 5, 2, 4	11, 12, 13, 10, 15, 3, 16, 2	X0–X7	Analog Switch Inputs X0–X7
16	14	V _{CC}	Positive Analog and Digital Supply Voltage Input
—	EP	PAD	Exposed Pad. Connect to GND.

High-Speed, Low-Voltage, 0.7Ω CMOS Analog Switches/Multiplexers

MAX4782 Pin Description

PIN		NAME	FUNCTION
TSSOP	THIN QFN		
1, 5, 2, 4	15, 3, 16, 2	Y0–Y3	Analog Switch Y Inputs Y0–Y3
3	1	Y	Analog Switch Y Output
6	4	$\overline{\text{ENABLE}}$	Digital Enable Input. Normally connect to GND. Drive to logic high to set all switches off.
7	5	N.C.	No Connection. Not internally connected.
8	6	GND	Ground
9	7	B	Digital Address B Input
10	8	A	Digital Address A Input
12, 14, 15, 11	10, 12, 13, 9	X0–X3	Analog Switch X Inputs X0–X3
13	11	X	Analog Switch X Output
16	14	VCC	Positive Analog and Digital Supply Voltage Input

MAX4783 Pin Description

PIN		NAME	FUNCTION
TSSOP	THIN QFN		
1	15	Y1	Analog Switch Y Normally Open Input
2	16	Y0	Analog Switch Y Normally Closed Input
3	1	Z1	Analog Switch Z Normally Open Input
4	2	Z	Analog Switch Z Output
5	3	Z0	Analog Switch Z Normally Closed Input
6	4	$\overline{\text{ENABLE}}$	Digital Enable Input. Normally connect to GND. Drive to logic high to set all switches off.
7	5	N.C.	No Connection. Not internally connected.
8	6	GND	Ground
9	7	C	Digital Address C Input
10	8	B	Digital Address B Input
11	9	A	Digital Address A Input
12	10	X0	Analog Switch X Normally Closed Input
13	11	X1	Analog Switch X Normally Open Input
14	12	X	Analog Switch X Output
15	13	Y	Analog Switch Y Output
16	14	VCC	Positive Analog and Digital Supply Voltage Input

MAX4781/MAX4782/MAX4783

High-Speed, Low-Voltage, 0.7Ω CMOS Analog Switches/Multiplexers

Applications Information

Power-Supply Considerations

Overview

The MAX4781/MAX4782/MAX4783 construction is typical of most CMOS analog switches. There are two supply inputs: V_{CC} and GND. V_{CC} and GND drive the internal CMOS switches and set the limits of the analog voltage on any switch. Internal reverse ESD-protection diodes are connected between each analog signal input and both V_{CC} and GND. If any analog signal exceeds V_{CC} or GND, one of these diodes conducts. During normal operation, these and other reverse-biased ESD diodes leak, forming the only current drawn from V_{CC} or GND.

Virtually all the analog leakage current comes from the ESD diodes. Although the ESD diodes on a given signal input are identical and therefore fairly well balanced, they are reverse-biased differently. Each diode is biased by either V_{CC} or GND and the analog signal. Their leakages vary as the signal varies. The difference in the two diodes' leakages to V_{CC} and GND constitutes the analog-signal-path leakage current. All analog leakage current flows between each input and one of the supply terminals, not to the other switch terminal. Both sides of a given switch can show leakage currents of either the same or opposite polarity.

V_{CC} and GND power the internal logic and set the input logic limits. Logic inputs have ESD-protection diodes to ground.

Power Supply

The MAX4781/MAX4782/MAX4783 operate from a single supply between +1.6V and +3.6V. Switch on-resistance increases as the supply voltage is lowered.

High-Frequency Performance

In 50Ω systems, signal response is reasonably flat up to 50MHz (see the *Typical Operating Characteristics*). Above 20MHz, the on-response has several minor peaks that are highly layout dependent. In the off state, the switch acts like a capacitor and passes higher frequencies with less attenuation. At 10MHz, off-isolation is approximately -50dB in 50Ω systems, becoming worse (approximately 20dB per decade) as frequency increases. Higher circuit impedance also degrades off-isolation. Adjacent channel attenuation is approximately 3dB above that of a bare IC socket and is entirely because of capacitive coupling.

Pin Nomenclature

The MAX4781/MAX4782/MAX4783 are pin compatible with the industry-standard 74HC4051/74HC4052/74HC4053 and the MAX4617/MAX4618/MAX4619. In single-supply applications, they function identically and have identical logic diagrams, although these parts differ electrically. The pin designations and logic diagrams in this data sheet conform to the original 1972 specifications published by RCA for the CD4051/CD4052/CD4053. These designations differ from the standard Maxim switch and mux designations found on other Maxim data sheets such as the MAX4051/MAX4052/MAX4053. Designers who are more comfortable with Maxim's standard designations are advised that the pin designations and logic diagrams on the MAX4051/MAX4052/MAX4053 data sheet can be applied to the MAX4781/MAX4782/MAX4783.

High-Speed, Low-Voltage, 0.7Ω CMOS Analog Switches/Multiplexers

MAX4781/MAX4782/MAX4783

Table 1. Truth Table/Switch Programming

ENABLE INPUT	SELECT INPUT			ON SWITCHES		
	C*	B	A	MAX4781	MAX4782	MAX4783
H	✓	✓	✓	All switches open	All switches open	All switches open
L	L	L	L	X-X0	X-X0 Y-Y0 Z-Z0	X-X0 Y-Y0 Z-Z0
L	L	L	H	X-X1	X-X1 Y-Y1	X-X1 Y-Y0 Z-Z0
L	L	H	L	X-X2	X-X2 Y-Y2	X-X0 Y-Y1 Z-Z0
L	L	H	H	X-X3	X-X3 Y-Y3	X-X1 Y-Y1 Z-Z0
L	H	L	L	X-X4	X-X0 Y-Y0	X-X0 Y-Y0 Z-Z1
L	H	L	H	X-X5	X-X1 Y-Y1	X-X1 Y-Y0 Z-Z1
L	H	H	L	X-X6	X-X2 Y-Y2	X-X0 Y-Y1 Z-Z1
L	H	H	H	X-X7	X-X3 Y-Y3	X-X1 Y-Y1 Z-Z1

✓ = Don't care.

*Not present on MAX4782.

Note: Input and output pins are identical and interchangeable. Either can be considered an input or output. Signals pass equally well in either direction.

High-Speed, Low-Voltage, 0.7Ω CMOS Analog Switches/Multiplexers

Test Circuits/Timing Diagrams

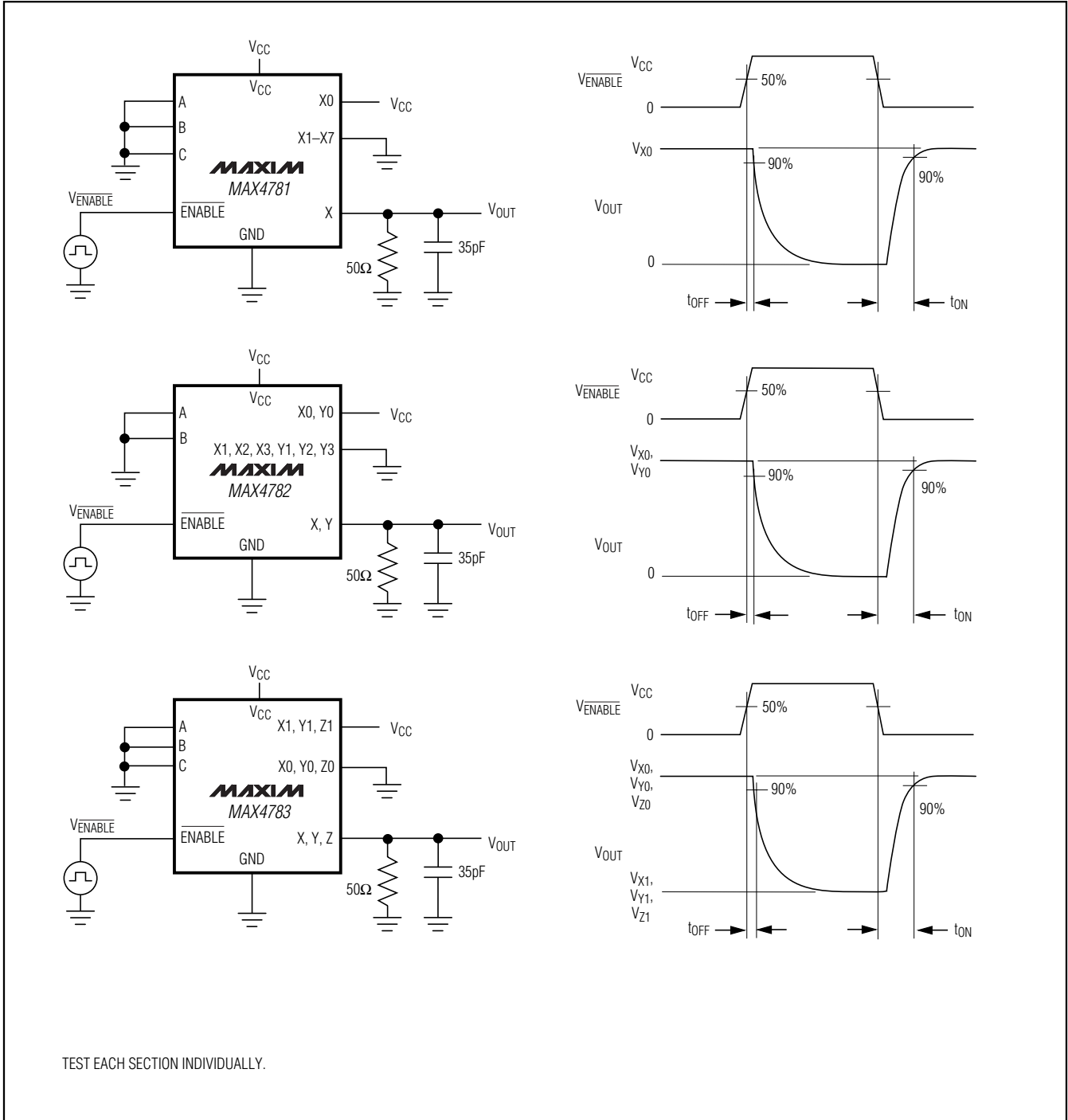

Figure 1. Enable Switching Times

High-Speed, Low-Voltage, 0.7Ω CMOS Analog Switches/Multiplexers

Test Circuits/Timing Diagrams (continued)

MAX4781/MAX4782/MAX4783

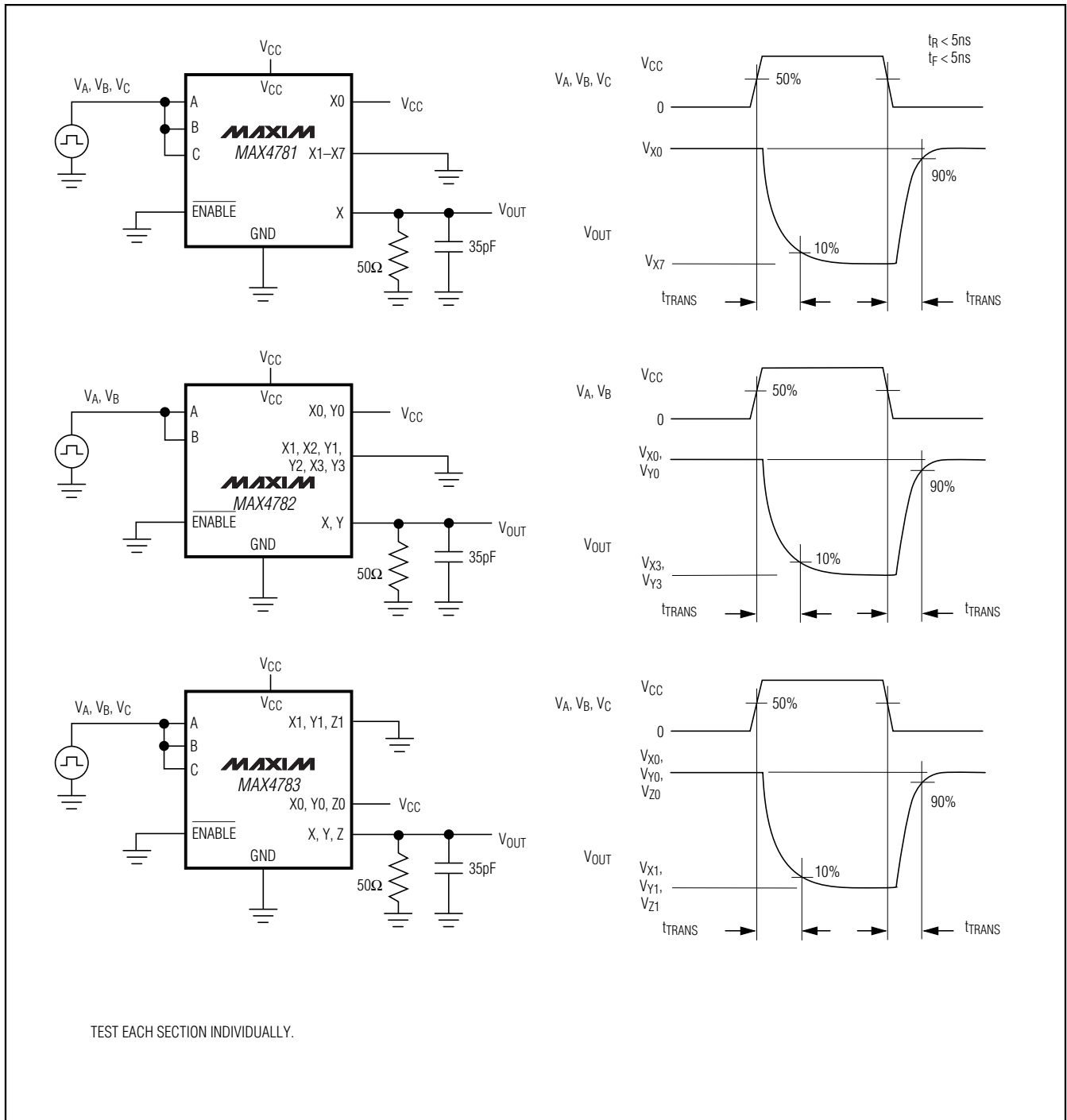

Figure 2. Address Transition Times

High-Speed, Low-Voltage, 0.7Ω CMOS Analog Switches/Multiplexers

Test Circuits/Timing Diagrams (continued)

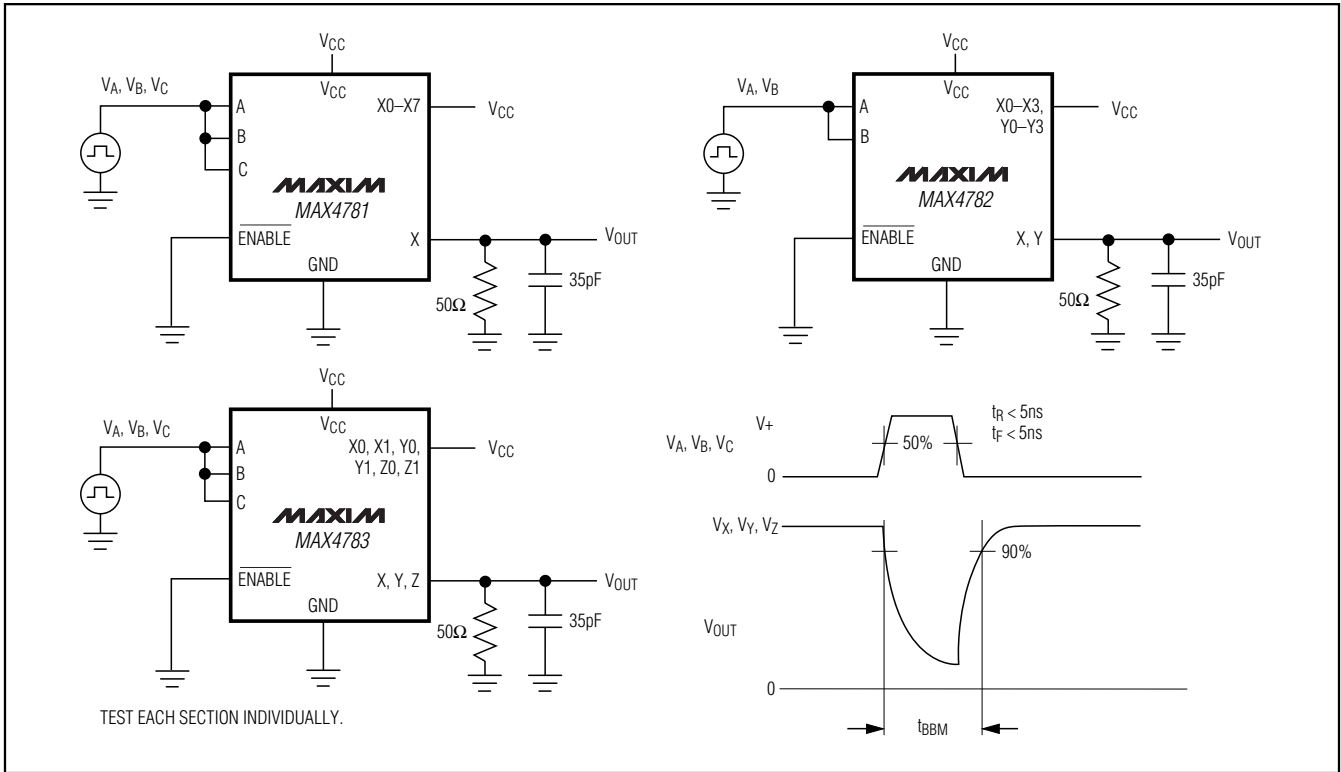

Figure 3. Break-Before-Make Interval

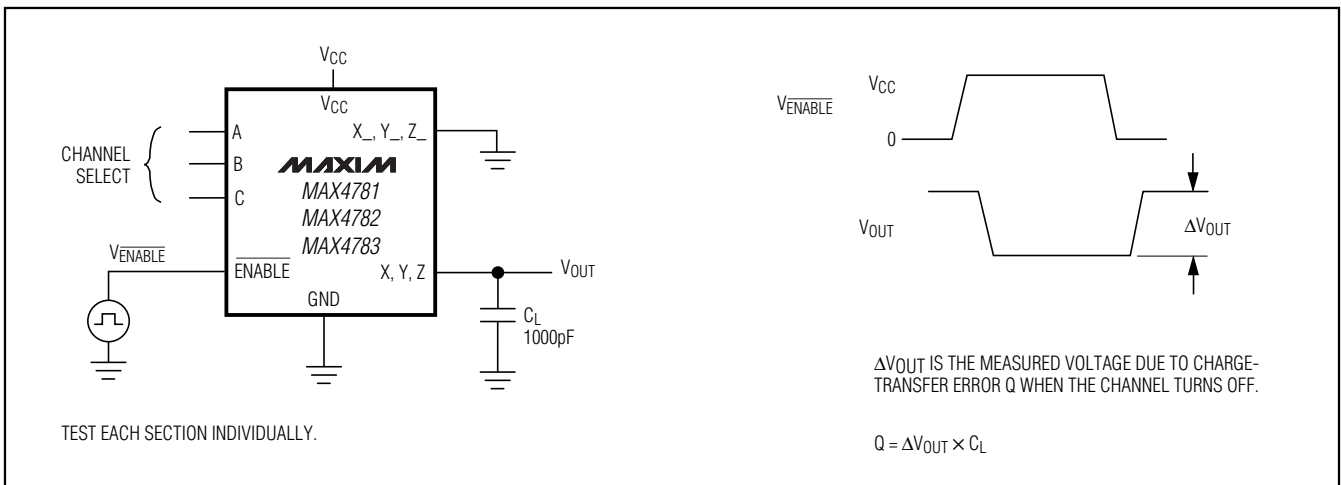

Figure 4. Charge Injection

High-Speed, Low-Voltage, 0.7Ω CMOS Analog Switches/Multiplexers

Test Circuits/Timing Diagrams (continued)

MAX4781/MAX4782/MAX4783

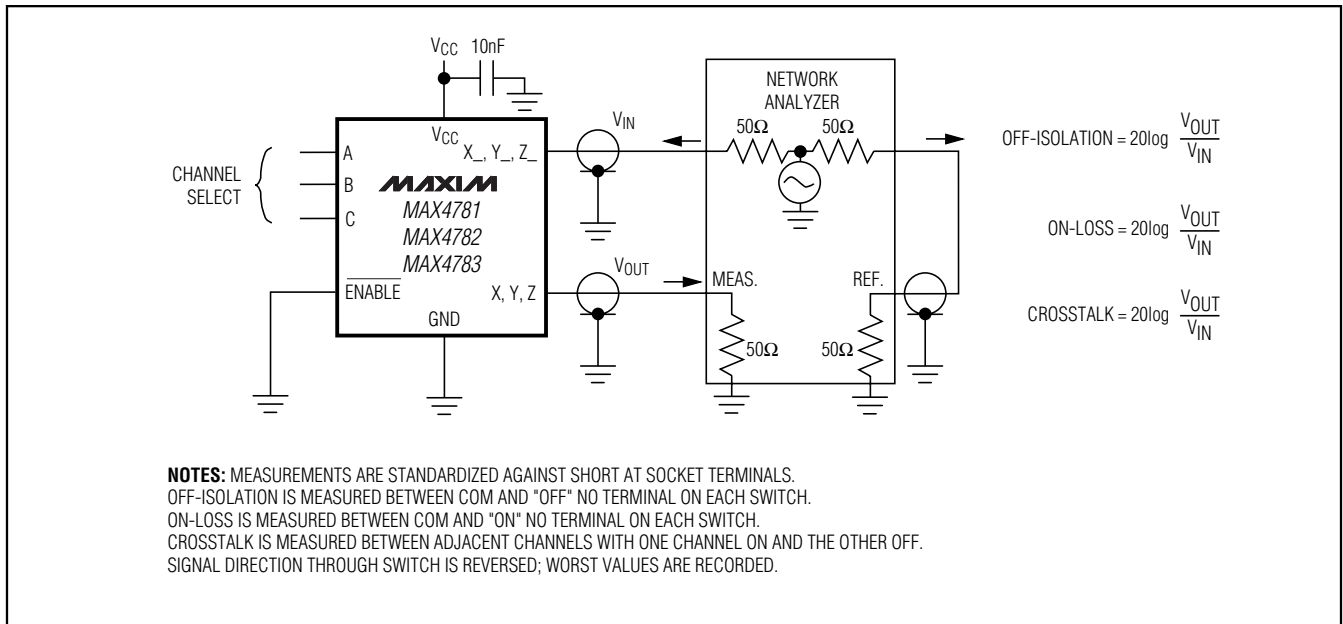

Figure 5. Off-Isolation, On-Loss, and Crosstalk

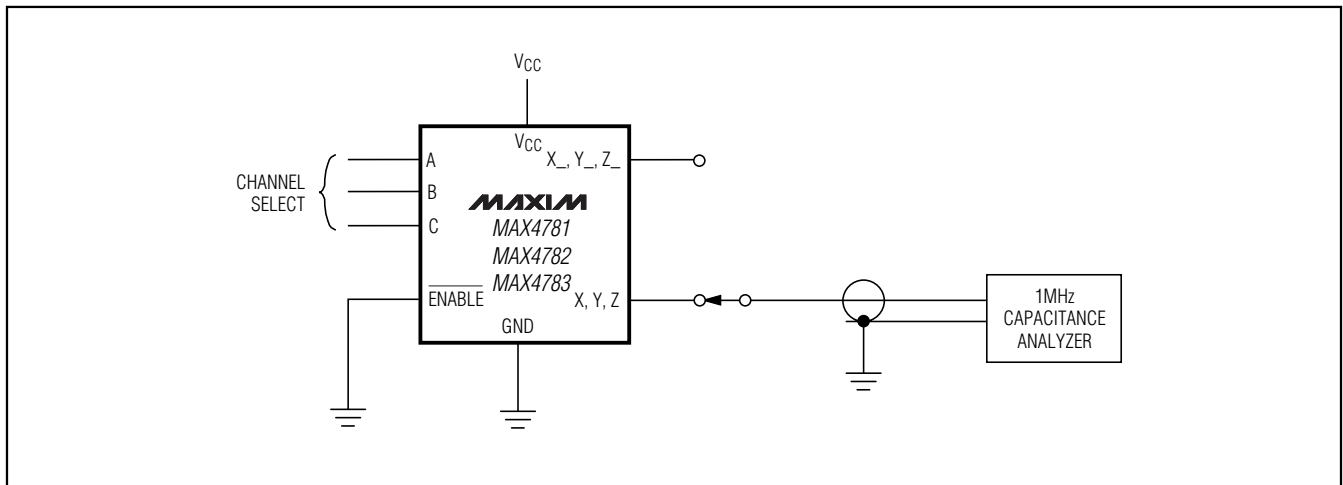

Figure 6. Capacitance

Chip Information

TRANSISTOR COUNT: 659

PROCESS: CMOS

High-Speed, Low-Voltage, 0.7Ω CMOS Analog Switches/Multiplexers

Pin Configurations/Functional Diagrams (continued)

TOP VIEW

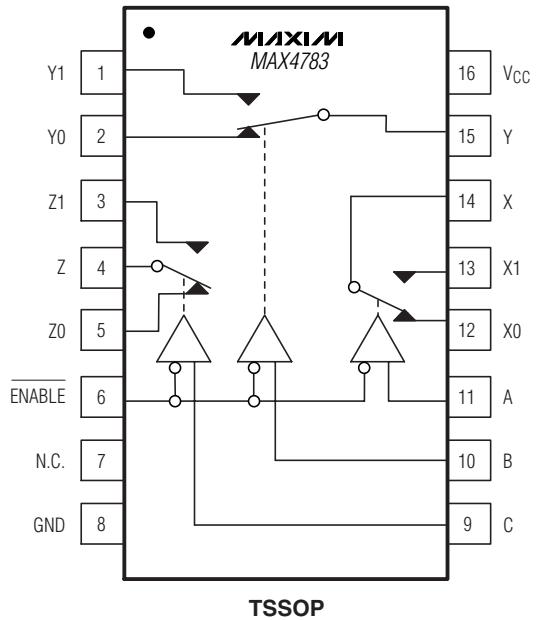
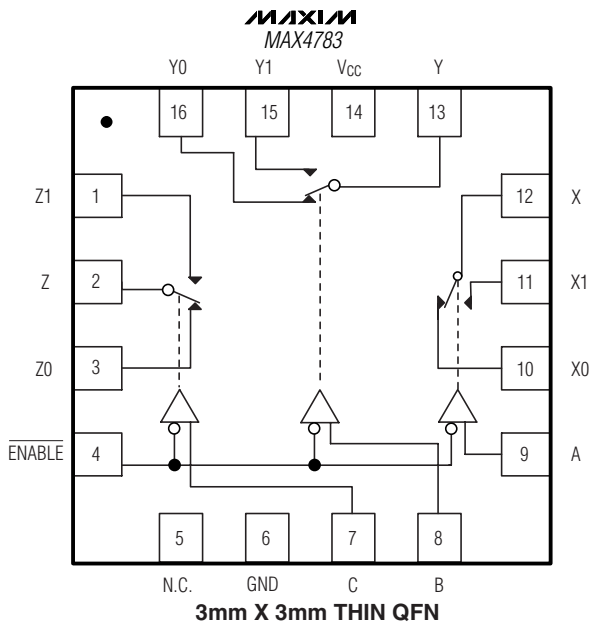
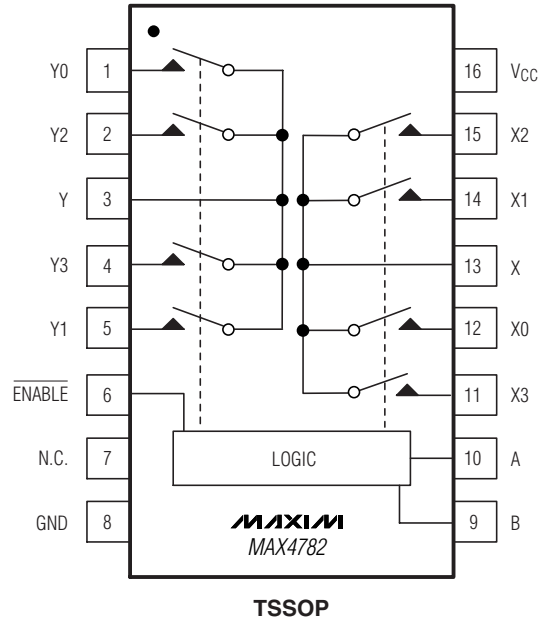
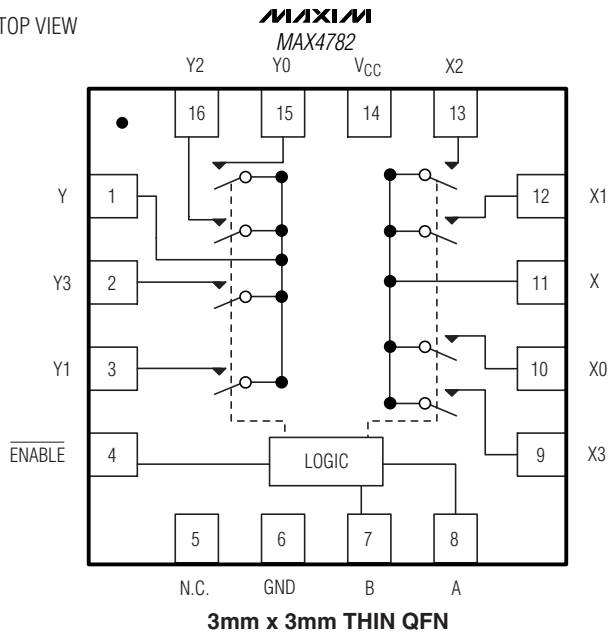

High-Speed, Low-Voltage, 0.7Ω CMOS Analog Switches/Multiplexers

Package Information

(The package drawing(s) in this data sheet may not reflect the most current specifications. For the latest package outline information, go to www.maxim-ic.com/packages.)

MAX4781/MAX4782/MAX4783

TSSOP4.40mm.EPS

COMMON DIMENSIONS

SYMBOL	MILLIMETERS		INCHES	
	MIN.	MAX.	MIN.	MAX.
A	—	1.10	—	.043
A ₁	0.05	0.15	.002	.006
A ₂	0.85	0.95	.033	.037
b	0.19	0.30	.007	.012
b ₁	0.19	0.25	.007	.010
c	0.09	0.20	.004	.008
c ₁	0.09	0.14	.004	.006
D	SEE VARIATIONS		SEE VARIATIONS	
E	4.30	4.50	.169	.177
e	0.65 BSC		.026 BSC	
H	6.25	6.55	.246	.258
L	0.50	0.70	.020	.028
N	SEE VARIATIONS		SEE VARIATIONS	
α	0°	8°	0°	8°

JEDEC	MD-153	N	VARIATIONS			
			MILLIMETERS		INCHES	
			MIN.	MAX.	MIN.	MAX.
AB-1	14	D	4.90	5.10	.193	.201
AB	16	D	4.90	5.10	.193	.201
AC	20	D	6.40	6.60	.252	.260
AD	24	D	7.70	7.90	.303	.311
AE	28	D	9.60	9.80	.378	.386

NOTES:

- DIMENSIONS D AND E DO NOT INCLUDE FLASH
- MOLD FLASH OR PROTRUSIONS NOT TO EXCEED 0.15mm PER SIDE
- CONTROLLING DIMENSION: MILLIMETER
- MEETS JEDEC OUTLINE MD-153. SEE JEDEC VARIATIONS TABLE
- "N" REFERS TO NUMBER OF LEADS
- THE LEAD TIPS MUST LIE WITHIN A SPECIFIED ZONE. THIS TOLERANCE ZONE IS DEFINED BY TWO PARALLEL PLANES. ONE PLANE IS THE SEATING PLANE, DATUM [-C-]; THE OTHER PLANE IS AT THE SPECIFIED DISTANCE FROM [-C-] IN THE DIRECTION INDICATED

High-Speed, Low-Voltage, 0.7Ω CMOS Analog Switches/Multiplexers

Package Information (continued)

(The package drawing(s) in this data sheet may not reflect the most current specifications. For the latest package outline information, go to www.maxim-ic.com/packages.)

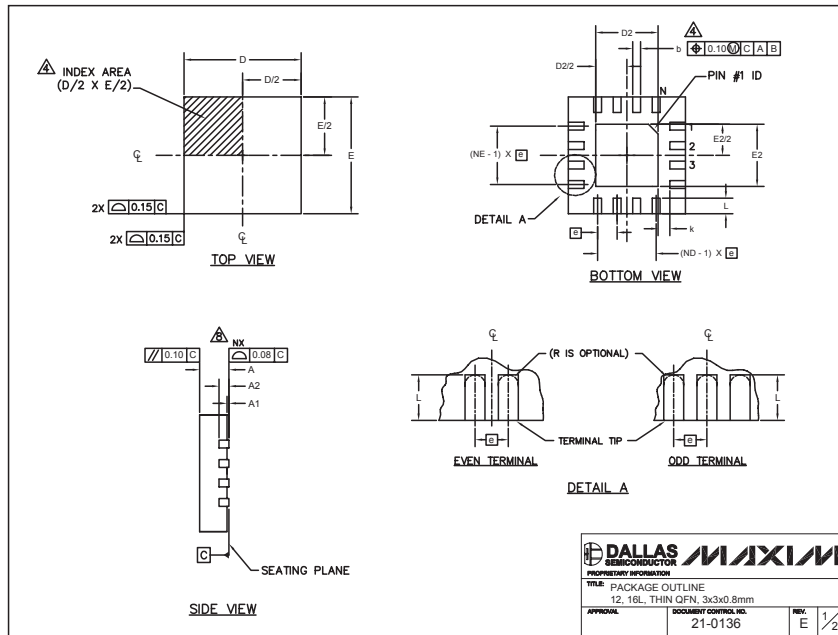

DALLAS SEMICONDUCTOR **MAXIM**

PROPRIETARY INFORMATION

TITLE PACKAGE OUTLINE
12, 16L, THIN OFN, 3x3x0.8mm

APPROVAL _____ DOCUMENT CONTROL NO. 21-0136 REV. E 1/2

PKG REF.	12L 3x3			16L 3x3		
	MIN.	NOM.	MAX.	MIN.	NOM.	MAX.
A	0.70	0.75	0.80	0.70	0.75	0.80
b	0.20	0.25	0.30	0.20	0.25	0.30
D	2.90	3.00	3.10	2.90	3.00	3.10
E	2.90	3.00	3.10	2.90	3.00	3.10
e	0.50 BSC.			0.50 BSC.		
L	0.45	0.55	0.65	0.30	0.40	0.50
N	12			16		
ND	3			4		
NE	3			4		
A1	0	0.02	0.05	0	0.02	0.05
A2	0.20 REF.			0.20 REF.		
k	0.25	-	-	0.25	-	-

PKG. CODES	D2			E2			PIN ID	JEDEC	DOWN BONDS ALLOWED
	MIN.	NOM.	MAX.	MIN.	NOM.	MAX.			
T1233-1	0.95	1.10	1.25	0.95	1.10	1.25	0.35 x 45°	WEED-1	NO
T1233-3	0.95	1.10	1.25	0.95	1.10	1.25	0.35 x 45°	WEED-1	YES
T1633-1	0.95	1.10	1.25	0.95	1.10	1.25	0.35 x 45°	WEED-2	NO
T1633-2	0.95	1.10	1.25	0.95	1.10	1.25	0.35 x 45°	WEED-2	YES
T1633F-3	0.65	0.80	0.95	0.65	0.80	0.95	0.225 x 45°	WEED-2	N/A
T1633-4	0.95	1.10	1.25	0.95	1.10	1.25	0.35 x 45°	WEED-2	NO

NOTES:

- DIMENSIONING & TOLERANCING CONFORM TO ASME Y14.5M-1994.
- ALL DIMENSIONS ARE IN MILLIMETERS. ANGLES ARE IN DEGREES.
- N IS THE TOTAL NUMBER OF TERMINALS.
- THE TERMINAL #1 IDENTIFIER AND TERMINAL NUMBERING CONVENTION SHALL CONFORM TO JEDEC 95-1 SPP-D12. DETAILS OF TERMINAL #1 IDENTIFIER ARE OPTIONAL, BUT MUST BE LOCATED WITHIN THE ZONE INDICATED. THE TERMINAL #1 IDENTIFIER MAY BE EITHER A MOLD OR MARKED FEATURE.
- DIMENSION b APPLIES TO METALLIZED TERMINAL AND IS MEASURED BETWEEN 0.20 mm AND 0.25 mm FROM TERMINAL TIP.
- ND AND NE REFER TO THE NUMBER OF TERMINALS ON EACH D AND E SIDE RESPECTIVELY.
- DEPOPULATION IS POSSIBLE IN A SYMMETRICAL FASHION.
- COPLANARITY APPLIES TO THE EXPOSED HEAT SINK SLUG AS WELL AS THE TERMINALS.
- DRAWING CONFORMS TO JEDEC MO220 REVISION C.

DALLAS SEMICONDUCTOR **MAXIM**

PROPRIETARY INFORMATION

TITLE PACKAGE OUTLINE
12, 16L, THIN OFN, 3x3x0.8mm



APPROVAL _____ DOCUMENT CONTROL NO. 21-0136 REV. E 1/2

Maxim cannot assume responsibility for use of any circuitry other than circuitry entirely embodied in a Maxim product. No circuit patent licenses are implied. Maxim reserves the right to change the circuitry and specifications without notice at any time.

16 **Maxim Integrated Products, 120 San Gabriel Drive, Sunnyvale, CA 94086 408-737-7600**

Looking for pricing, stock, or lifecycle information?

Click below to explore more details on WIN SOURCE:

-  [View MAX4781EGE+T on WIN SOURCE](#)
-  [Maxim Integrated Information](#)

Optimize Your Supply Chain with WIN SOURCE Solutions

-  Global Sourcing Solution
-  Obsolete Management
-  Cost Control Management
-  Shortage Management
-  Alternative Solution
-  Excess Inventory Management