



**THE DATASHEET OF
MAX5917BESE+**





+65V Simple Swapper Hot-Swap Switches

MAX5910/MAX5917

General Description

The MAX5910/MAX5917 are fully integrated hot-swap switches for positive supply rails. These devices allow the safe insertion and removal of circuit cards into live backplanes or ports without causing glitches on the backplane power-supply rail. They also monitor various circuit parameters and disconnect the load if a fault condition occurs, alerting the host with a logic-level IFAULT output. The MAX5910/MAX5917 operate over a +10V to +65V input voltage range. They are designed to permit hot plugging of an internet appliance such as an IP phone but are not limited to that application.

During startup, an internal power FET regulates the current between the backplane power source and the load to 280mA for the MAX5910, 567mA for the MAX5917A, and 420mA for the MAX5917B. After startup, the FET is fully enhanced to reduce its on-resistance. To ensure robust operation, the MAX5910/MAX5917 contain built-in safety features that prevent damage to the internal FET. They include an enable input, which responds to positive logic signals (+3.3V or +5V), allowing the host system to disconnect the load.

The MAX5910/MAX5917 Simple Swapper™ hot-swap ICs monitor four parameters for fault conditions: undervoltage lockout (UVLO), power-not-good, zero-current detection, and thermal shutdown. These devices are available in the extended temperature range, -40°C to +85°C. The MAX5910 comes in an 8-pin SO package and the MAX5917A/B is available in a 16-pin SO package.

Applications

- IP Phones
- Power-Over-LAN
- Power-Over-MDI
- Remote Power Distribution
- Network Routers
- Network Switches
- Internet Appliances

Pin Configurations appear at end of data sheet.

Simple Swapper is a trademark of Maxim Integrated Products, Inc.

Features

- ◆ Provides Safe Hot Swap for +10V to +65V Power Supplies
- ◆ IEEE 802.3af Compliant (MAX5917A)
- ◆ Startup into 500µF Load (MAX5917A)
- ◆ 280mA Current Limit for MAX5910
- ◆ 567mA Current Limit for MAX5917A
- ◆ 420mA Current Limit for MAX5917B
- ◆ Zero-Current Load Detection
- ◆ Integrated 2.2Ω Power FET
- ◆ Status Output Reports Fault Conditions
- ◆ Internal Switch-Protection Circuitry
- ◆ Built-In Thermal Shutdown

Ordering Information

PART	TEMP. RANGE	PIN-PACKAGE
MAX5910ESA	-40°C to +85°C	8 SO
MAX5917AESE*	-40°C to +85°C	16 SO
MAX5917BESE	-40°C to +85°C	16 SO

*Future product—contact factory for availability.

Typical Operating Circuit

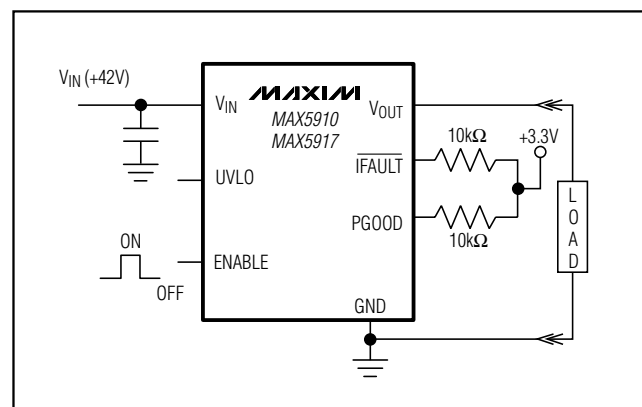

+65V Simple Swapper Hot-Swap Switches

ABSOLUTE MAXIMUM RATINGS

V_{IN} , V_{OUT} to GND -0.3V to +70.0V
 ENABLE to GND -0.3V to +12.0V
 PGOOD, IFAULT to GND -0.3V to +12.0V
 UVLO to GND -0.3V to ($V_{IN} + 0.3V$)
 PGOOD, IFAULT Sink Current 10mA
 Continuous Power Dissipation ($T_A = +70^\circ\text{C}$)
 8-Pin SO (derate 5.9mW/ $^\circ\text{C}$ above +70 $^\circ\text{C}$) 470mW
 16-Pin SO (derate 12.9mW/ $^\circ\text{C}$ above +70 $^\circ\text{C}$) 1039mW

Operating Temperature Range -40 $^\circ\text{C}$ to +85 $^\circ\text{C}$
 Maximum Junction Temperature +150 $^\circ\text{C}$
 Storage Temperature Range -60 $^\circ\text{C}$ to +150 $^\circ\text{C}$
 Lead Temperature (soldering 10s) +300 $^\circ\text{C}$

Stresses beyond those listed under "Absolute Maximum Ratings" may cause permanent damage to the device. These are stress ratings only, and functional operation of the device at these or any other conditions beyond those indicated in the operational sections of the specifications is not implied. Exposure to absolute maximum rating conditions for extended periods may affect device reliability.

ELECTRICAL CHARACTERISTICS

($V_{IN} = +42V$, GND = 0, UVLO = open circuit, $V_{ENABLE} = +3.3V$, and $T_A = -40^\circ\text{C}$ to +85 $^\circ\text{C}$, unless otherwise noted. Typical values are at $T_A = +25^\circ\text{C}$.)

PARAMETER	SYMBOL	CONDITIONS	MIN	TYP	MAX	UNITS	
Input Voltage Range	V_{IN}		10		65	V	
Supply Current	I_{IN}	$V_{IN} = 10V$ to 65V (Note 1)		1.2	2.5	mA	
Output Current Limit	I_{LIM}	$V_{OUT} = V_{IN} - 5V$, $V_{IN} = 10V$ to 65V	MAX5910	250	280	310	mA
			MAX5917A	510	567	623	
			MAX5917B	370	420	470	
Continuous Operating Output Current	I_{OUT}	(Note 2)	MAX5910		240	mA	
			MAX5917A		400		
			MAX5917B		350		
DMOS On-Resistance	$R_{DS(ON)}$	$V_{IN} = 10V$ to 65V, MAX5910, $I_{OUT} = 200mA$ MAX5917A, $I_{OUT} = 400mA$ MAX5917B, $I_{OUT} = 300mA$		2.2	4	Ω	
ENABLE Voltage Logic Low	V_{LOW}				0.8	V	
ENABLE Voltage Logic High	V_{HIGH}		2.4			V	
ENABLE High Input Current	I_{IH}	$V_{ENABLE} = +5V$			1	μA	
IFault Output Leakage Current	I_{OH}	$\overline{IFault} = 10V$, $I_{OH} > (I_{FTH} + I_{FHYS})$			1	μA	
PGOOD Output Leakage Current	I_{LPGOOD}	PGOOD = 10V, $V_{OUT} > V_{PG}$			1	μA	
V_{IN} to V_{OUT} Leakage Current	$I_{L_{IN/OUT}}$	ENABLE = 0, $V_{IN} = +65V$			1	μA	
PGOOD/ \overline{IFault} Output Logic Low	V_{OL}	Sink current = 3mA			0.4	V	
PGOOD Threshold	V_{PG}	Percentage of V_{IN} , V_{OUT} rising	71	78	85	%	
PGOOD Hysteresis	PG_{HYS}	Percentage of V_{IN}		10		%	
Zero-Current Detection Threshold	I_{FTH}	Decreasing output current	MAX5910	2	12	25	mA
			MAX5917A	2	6	10	
			MAX5917B	2	12	25	

+65V Simple Swapper Hot-Swap Switches

MAX5910/MAX5917

ELECTRICAL CHARACTERISTICS (continued)

($V_{IN} = +42V$, $GND = 0$, $UVLO = \text{open circuit}$, $V_{ENABLE} = +3.3V$, and $T_A = -40^\circ C$ to $+85^\circ C$, unless otherwise noted. Typical values are at $T_A = +25^\circ C$.)

PARAMETER	SYMBOL	CONDITIONS	MIN	TYP	MAX	UNITS
Zero-Current Detection Threshold Hysteresis	I_{FHYS}	Percentage of I_{FTH}		10		%
\overline{FAULT} Output Delay	t_{IFD}	(Figure 1)	7	12	17	ms
PGOOD Output Delay	t_{PGD}	(Figure 2)	7	12	17	ms
Thermal Shutdown Temperature	T_J	Die temperature increasing		140		$^\circ C$
Thermal Shutdown Hysteresis	T_{JHYS}			3.5		$^\circ C$
Default Undervoltage Lockout	V_{UVLO}	V_{IN} decreasing	24.5	26.5	28.5	V
Undervoltage Lockout Hysteresis	$UVLO_{HYS}$	Percentage of V_{UVLO}		11		%
Minimum Undervoltage Lockout Threshold	$V_{UVLO} (MIN)$	$UVLO$ connected to V_{IN} , V_{IN} decreasing	7	7.5	8	V
Undervoltage Lockout Input Resistance	R_{UVLO}	Force $I = 5\mu A$ into $UVLO$ pin	260			$k\Omega$

Note 1: Measured at GND pin at the end of the output voltage slew.

Note 2: Guaranteed by $R_{DS(on)}$ test. Limited by package power dissipation.

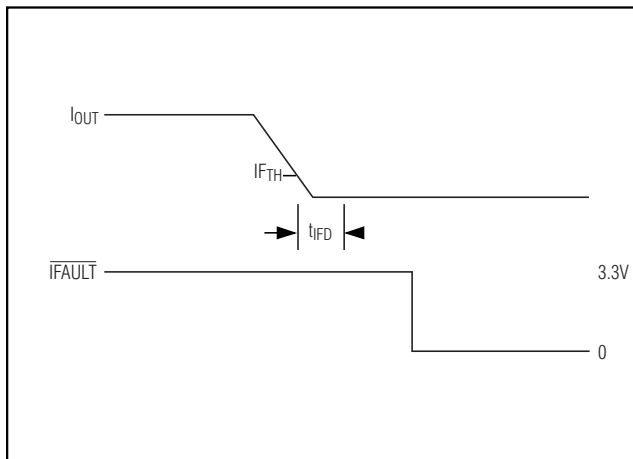

Figure 1. \overline{FAULT} Delay

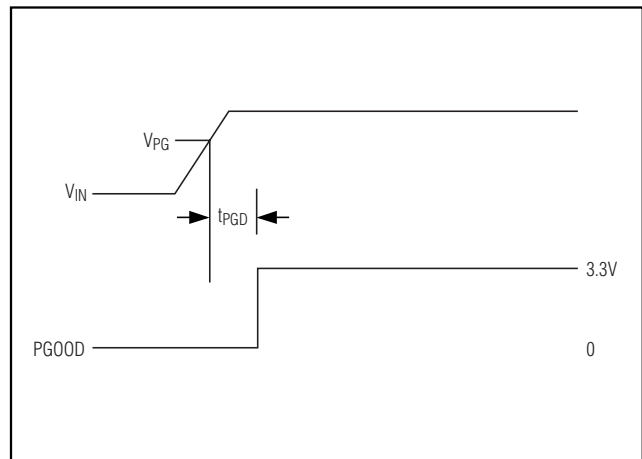
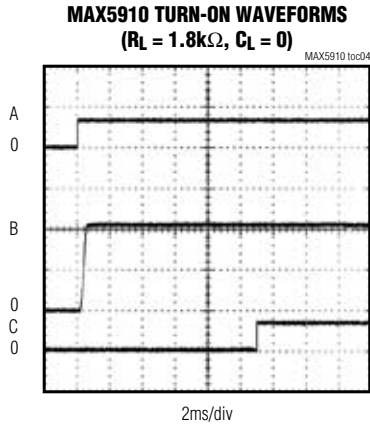
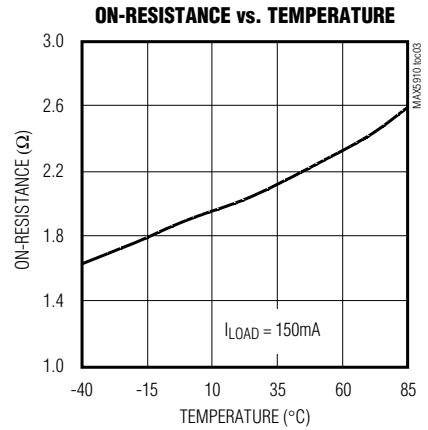
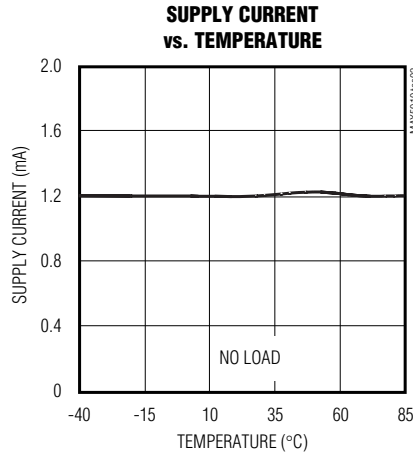
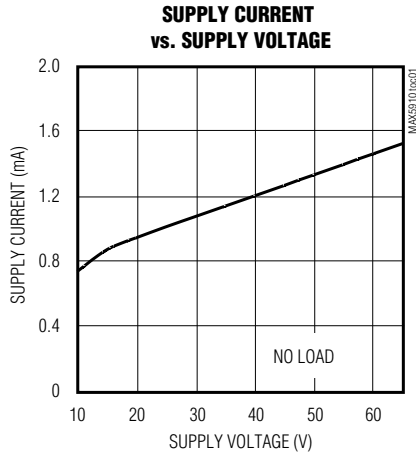

Figure 2. Power-Good Delay

+65V Simple Swapper Hot-Swap Switches

Typical Operating Characteristics

($V_{IN} = +42V$, $GND = 0$, $UVLO = \text{open circuit}$, $V_{ENABLE} = 3.3V$, $R_L = 1.8k\Omega$, $T_A = +25^\circ C$, unless otherwise noted).



A: ENABLE, 5V/div
B: V_{OUT} , 20V/div
C: PGOOD, 5V/div

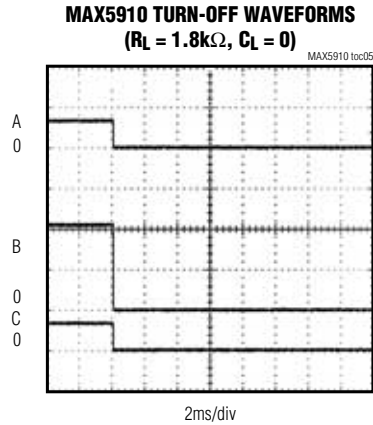

A: ENABLE, 5V/div
B: V_{OUT} , 20V/div
C: PGOOD, 5V/div

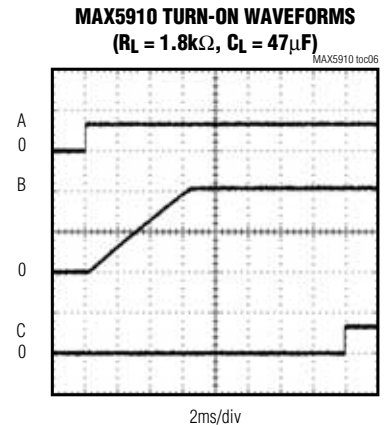

A: ENABLE, 5V/div
B: V_{OUT} , 20V/div
C: PGOOD, 5V/div

+65V Simple Swapper Hot-Swap Switches

MAX5910/MAX5917

Typical Operating Characteristics (continued)

($V_{IN} = +42V$, $GND = 0$, $UVLO = \text{open circuit}$, $V_{ENABLE} = 3.3V$, $R_L = 1.8k\Omega$, $T_A = +25^\circ C$, unless otherwise noted).

MAX5910 TURN-OFF WAVEFORMS
($R_L = 1.8k\Omega$, $C_L = 47\mu F$)

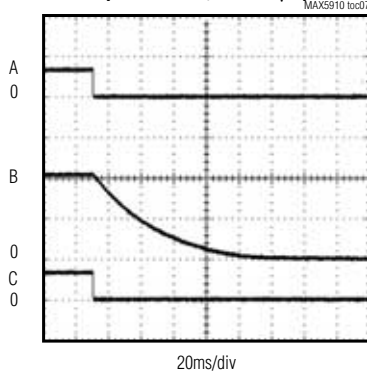

A: ENABLE, 5V/div
B: V_{OUT} , 20V/div
C: PGOOD, 5V/div

MAX5910 ZERO-CURRENT RESPONSE

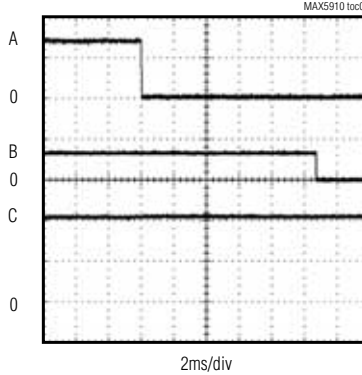

A: I_{OUT} , 100mA/div
B: IFAULT, 5V/div
C: V_{OUT} , 20V/div

MAX5910 OVER-CURRENT RESPONSE

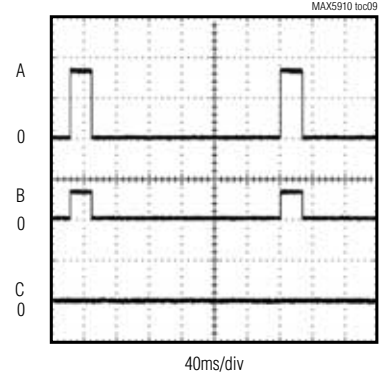

A: I_{OUT} , 200mA/div
B: IFAULT, 5V/div
C: V_{OUT} , 20V/div (SHORTED TO GND)

MAX5917B TURN-ON WAVEFORMS
($R_L = 1.8k\Omega$, $C_L = 0$)

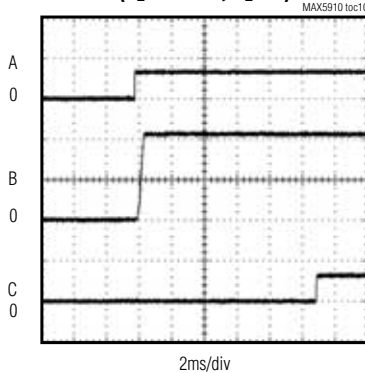

A: ENABLE, 5V/div
B: V_{OUT} , 20V/div
C: PGOOD, 5V/div

MAX5917B TURN-OFF WAVEFORMS
($R_L = 1.8k\Omega$, $C_L = 0$)

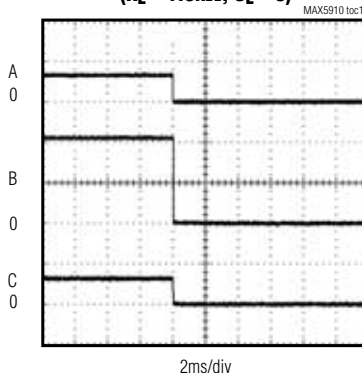

A: ENABLE, 5V/div
B: V_{OUT} , 20V/div
C: PGOOD, 5V/div

MAX5917B TURN-ON WAVEFORMS
($R_L = 1\Omega$, $C_L = 47\mu F$)

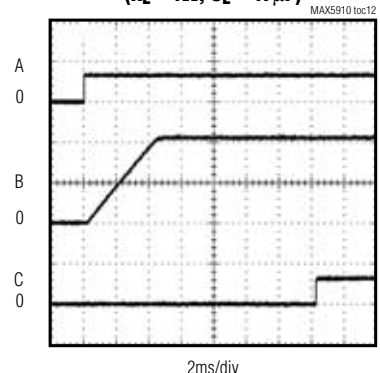

A: ENABLE, 5V/div
B: V_{OUT} , 20V/div
C: PGOOD, 5V/div

+65V Simple Swapper Hot-Swap Switches

Typical Operating Characteristics (continued)

($V_{IN} = +42V$, $GND = 0$, $UVLO = \text{open circuit}$, $V_{ENABLE} = 3.3V$, $R_L = 1.8k\Omega$, $T_A = +25^\circ C$, unless otherwise noted).

MAX5917B TURN-OFF WAVEFORMS
($R_L = 1.8k\Omega$, $C_L = 47\mu F$)

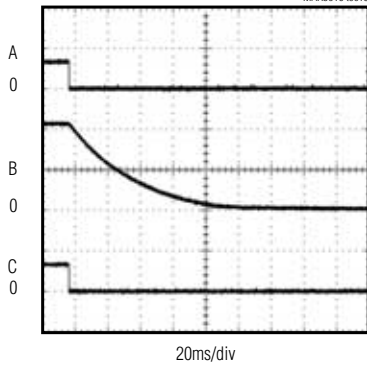

MAX5917B TURN-ON WAVEFORMS
($R_L = 300\Omega$, $C_L = 500\mu F$)

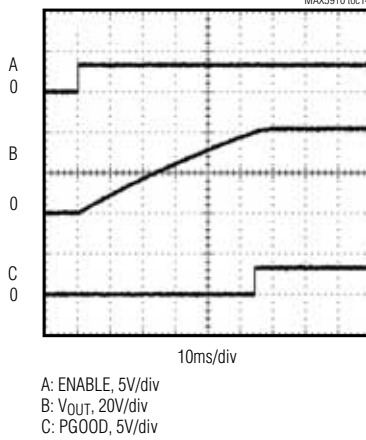

MAX5917B TURN-OFF WAVEFORMS
($R_L = 300\Omega$, $C_L = 500\mu F$)

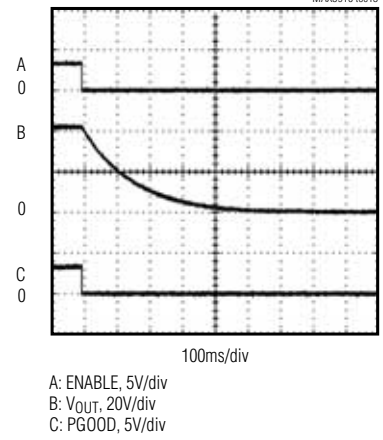

MAX5917B ZERO-CURRENT RESPONSE

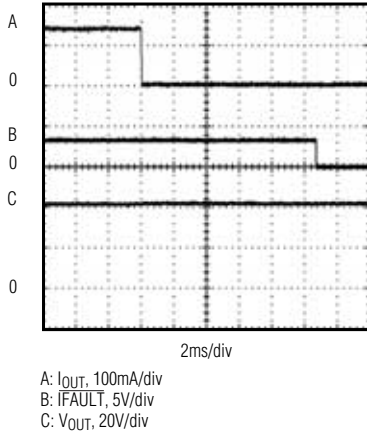

MAX5917B OVER-CURRENT RESPONSE

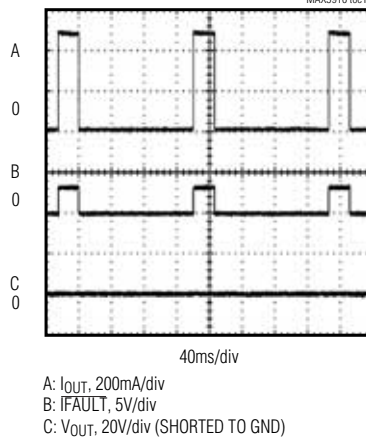

MAX5910 I_{OUT} vs. TEMPERATURE

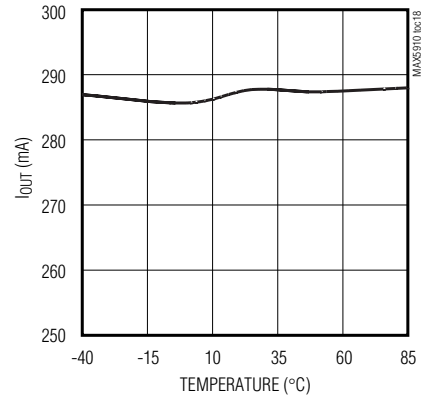

+65V Simple Swapper Hot-Swap Switches

MAX5910/MAX5917

Typical Operating Characteristics (continued)

($V_{IN} = +42V$, $GND = 0$, $UVLO = \text{open circuit}$, $V_{ENABLE} = 3.3V$, $R_L = 1.8k\Omega$, $T_A = +25^\circ C$, unless otherwise noted).

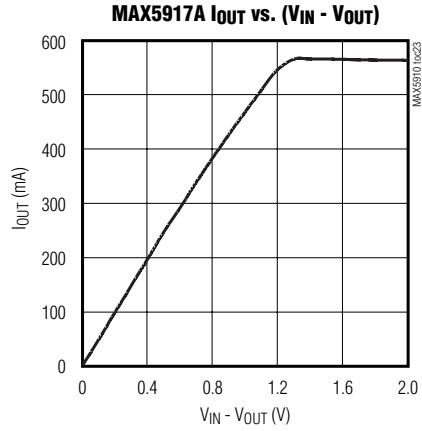
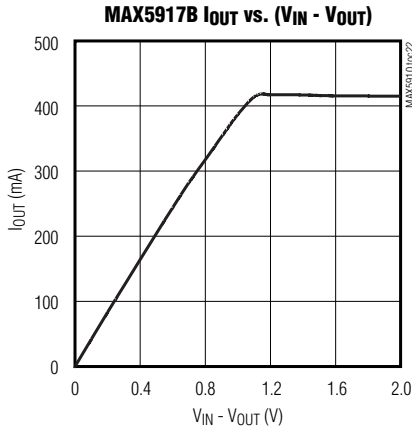
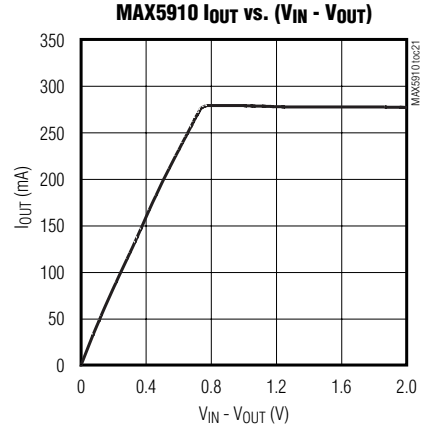
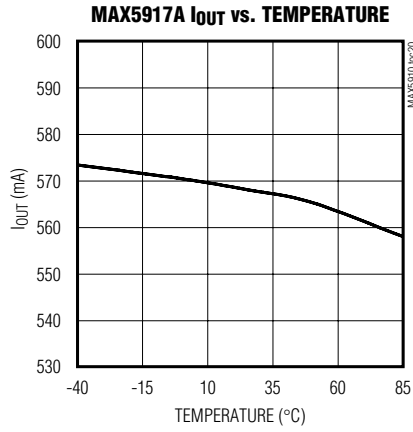
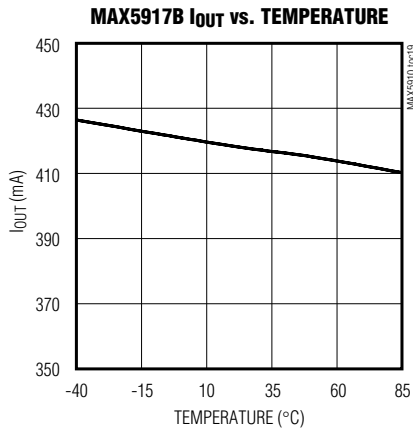

+65V Simple Swapper Hot-Swap Switches

Pin Description

PIN		NAME	FUNCTION
MAX5910	MAX5917A/B		
1	2	UVLO	Undervoltage Lockout Input. Leave UVLO open circuit for the default setting of 26.5V. Alternatively, UVLO can be connected to a resistive-divider to set a desired lockout voltage. See the <i>Changing the Undervoltage Lockout Setting</i> section.
2	3	V _{IN}	Voltage Input Terminal. Bypass V _{IN} to GND with a 0.1μF capacitor to improve noise immunity.
3	1, 6, 8, 9, 15, 16	N.C.	No Connection. Not internally connected.
4	7	ENABLE	3.3V Logic Input (TTL compatible), Active-High. Turns the internal FET on or off. Drive ENABLE high to enable V _{OUT} . Drive ENABLE low to disable V _{OUT} .
5	10	PGOOD	Open-Drain Logic Output, Active-High. PGOOD signals that the output is within specification. When the output is less than 70% of the input, the PGOOD signal is pulled low. Connect a 10kΩ pullup resistor (R) to 3.3V.
6	11	$\overline{\text{IFault}}$	Open-Drain Logic Output, Active-Low. $\overline{\text{IFault}}$ is asserted when the output current falls below the I _{FTH} nominal threshold or when the switch is off. Connect a 10kΩ pullup resistor (R) to 3.3V.
7	4, 5, 12, 13	GND	Ground
8	14	V _{OUT}	Voltage Output Terminal

Detailed Description

The MAX5910/MAX5917 are fully integrated hot-swap switches for positive power-supply rails. The devices allow safe insertion and removal of circuit cards into live backplanes or ports without causing glitches on the backplane power-supply rail. During startup these devices act as current regulators using their on-board FET to limit the amount of current drawn by the load to 280mA for MAX5910, 567mA for MAX5917A, and 420mA for MAX5917B. If the required load current exceeds that current limit, the internal switch behaves like a constant current source.

The MAX5910/MAX5917 monitor the input voltage, the output voltage, the output current, and the die temperature. They assert $\overline{\text{IFault}}$ and PGOOD accordingly if they detect an error condition.

A zero-current load detection feature activates if the load current drops below I_{FTH} for over 12ms. The MAX5910/MAX5917 also include an ENABLE input allowing the host system to turn the FET on or off.

Normal Operation

Startup

When power is first applied with ENABLE high, or when ENABLE is asserted, the MAX5910/MAX5917A/MAX5917B limit the current to the load to 280mA/567mA/420mA. PGOOD is asserted high 12ms after the output voltage exceeds the power-good threshold. PGOOD is pulled low if V_{OUT} is less than 70% V_{IN}.

Zero-Current Load Fault

A zero-current load detection feature activates if the load current drops below I_{FTH} for more than 12ms. The MAX5910/MAX5917 flag the zero-current condition but do not disconnect the load. $\overline{\text{IFault}}$ is deasserted whenever the load current exceeds the I_{FTH} + I_{FHYS} zero-current detection threshold.

Undervoltage Lockout Fault

If V_{IN} ≤ UVLO, where UVLO is the desired voltage at which the UVLO fault occurs, the internal FET is turned off and $\overline{\text{IFault}}$ and PGOOD are pulled low. The default UVLO voltage is 26.5V, but it can be adjusted using an external resistive-divider (see the *Changing the Undervoltage Lockout Setting* section).

+65V Simple Swapper Hot-Swap Switches

Thermal Shutdown Fault

The MAX5910/MAX5917 monitor their internal die temperature. If the temperature of the die exceeds +140°C, the internal FET is turned off and $\overline{\text{IFAULT}}$ and PGOOD are pulled low. The output is enabled again only when the die temperature is below the thermal shutdown temperature by 3.5°C typically.

Power-Good (PGOOD)

Power-good (PGOOD) logic output signals when the output has exceeded the PGOOD threshold. When the output voltage is below 70% of the input voltage, PGOOD is pulled low. When the output voltage is larger than 80% of the input voltage for more than 12ms, PGOOD is asserted.

Applications Information

Choosing a Device

The MAX5910 can output 280mA, the MAX5917B can output 420mA, and the MAX5917A can output up to 567mA. In applications where high power is expected, use the MAX5917 for its superior heat dissipation properties, and always solder all of its GND pins to a large section of circuit board copper.

Logic Control

The enable input (ENABLE) responds to 3.3V logic signals and will force the internal FET off if ENABLE is pulled low. This feature allows the host to disconnect the load from the power bus if required. Drive ENABLE high to enable V_{OUT} .

Changing the Undervoltage Lockout Setting

The undervoltage lockout (UVLO) value defaults to 26.5V if the UVLO pin is left open circuit (Figure 3). Connect UVLO to V_{IN} to set the undervoltage lockout to a minimum of 7.5V (Figure 4). This lockout voltage can also be changed with a resistive-divider from V_{IN} to GND. The center node of the divider is connected to the UVLO pin (Figure 5). The values of R1 and R2 must satisfy the condition $R1/R2 \ll 260k\Omega$ and $R2 \ll 1.65M\Omega$. R2 can be calculated as follows:

$$R2 = R1 \times [(V_{\text{UVLO}} / 7.5V) - 1]$$

where V_{IN} (UVLO) is the desired lockout voltage.

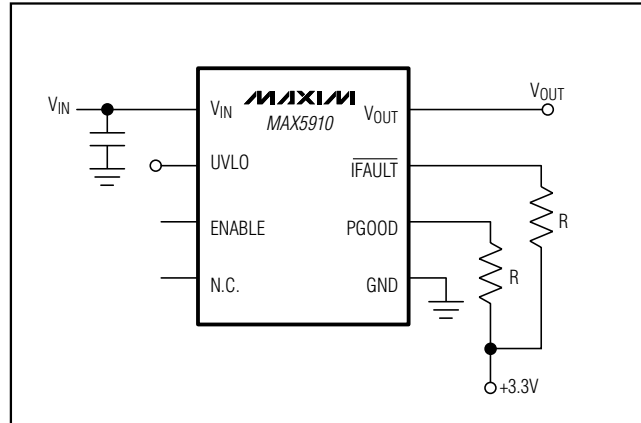

Figure 3. UVLO is Set Internally to its +26.5V Default Value

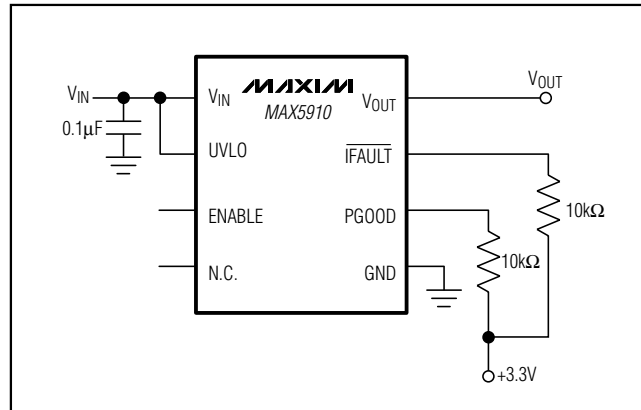

Figure 4. Minimum +7.5V UVLO Configuration

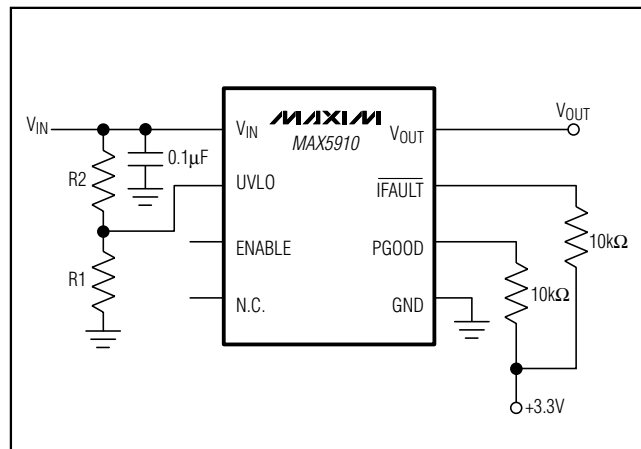
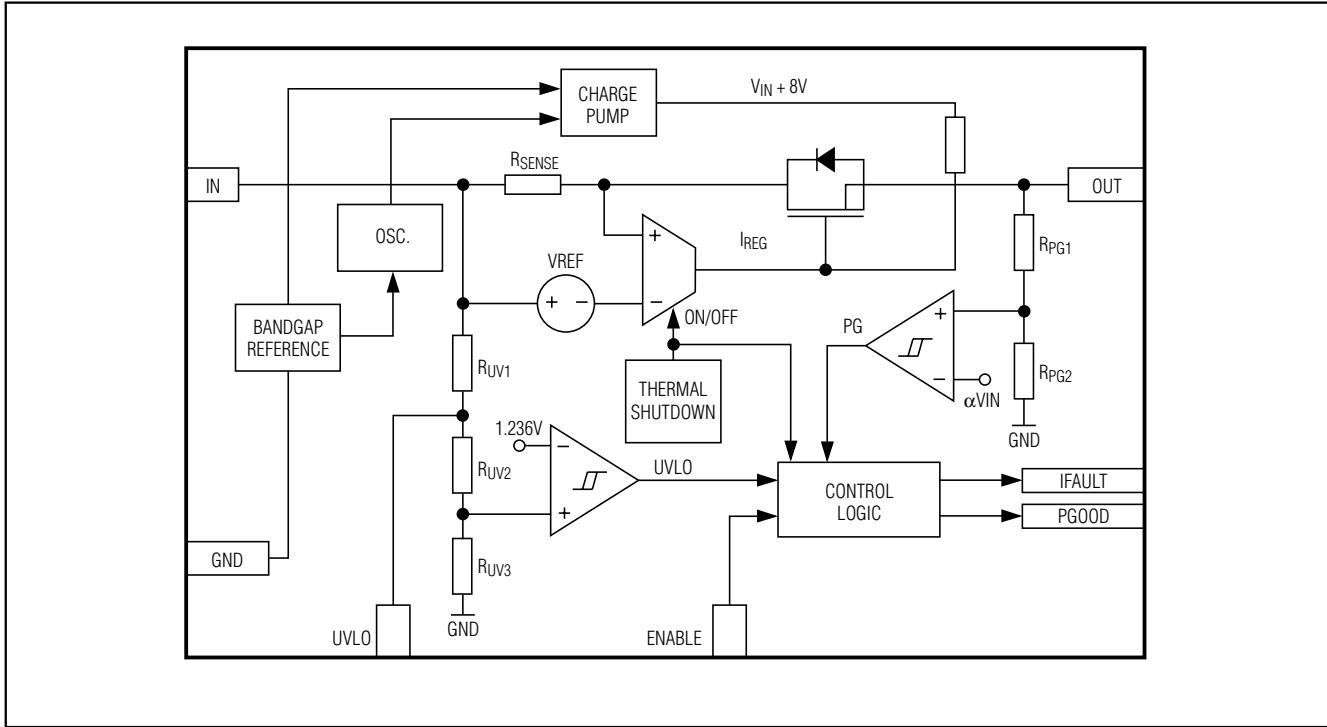

Figure 5. Adjusting UVLO with an External Resistive-Divider

+65V Simple Swapper Hot-Swap Switches

Functional Diagram



Pin Configurations

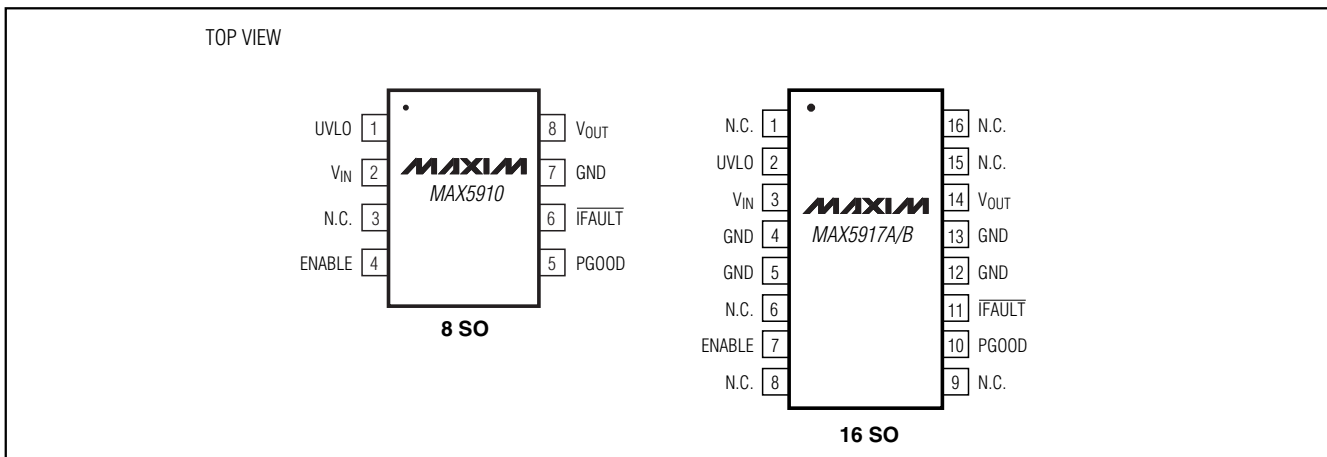

+65V Simple Swapper Hot-Swap Switches

Chip Information

TRANSISTOR COUNT: 1003

PROCESS: SG3ISO

Package Information

MAX5910/MAX5917

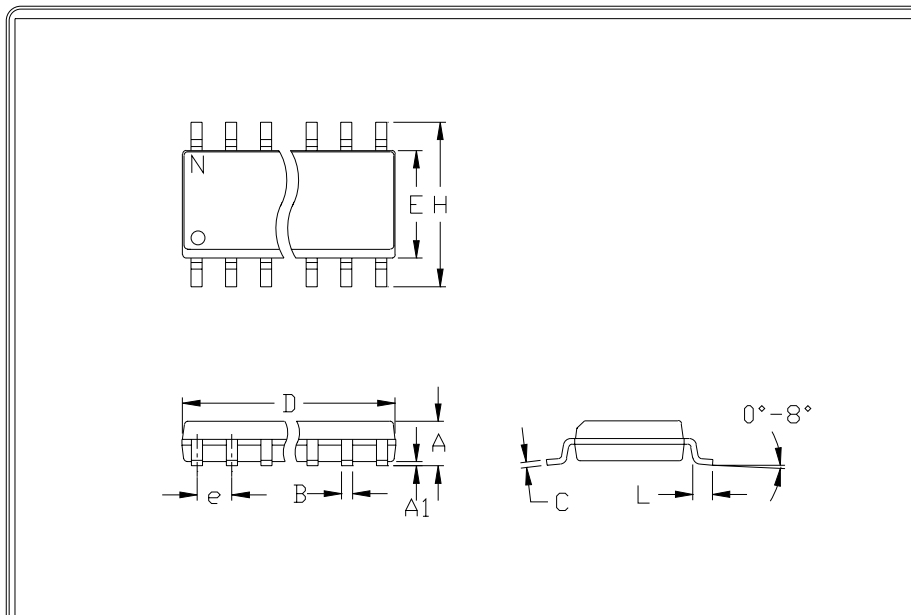

	INCHES		MILLIMETERS	
	MIN	MAX	MIN	MAX
A	0.053	0.069	1.35	1.75
A1	0.004	0.010	0.10	0.25
B	0.014	0.019	0.35	0.49
C	0.007	0.010	0.19	0.25
e	0.050		1.27	
E	0.150	0.157	3.80	4.00
H	0.228	0.244	5.80	6.20
h	0.010	0.020	0.25	0.50
L	0.016	0.050	0.40	1.27

	INCHES		MILLIMETERS		N	MS012
	MIN	MAX	MIN	MAX		
D	0.189	0.197	4.80	5.00	8	A
D	0.337	0.344	8.55	8.75	14	B
D	0.386	0.394	9.80	10.00	16	C

NOTES:

1. D&E DO NOT INCLUDE MOLD FLASH
2. MOLD FLASH OR PROTRUSIONS NOT TO EXCEED .15mm (.006")
3. LEADS TO BE COPLANAR WITHIN .102mm (.004")
4. CONTROLLING DIMENSION: MILLIMETER
5. MEETS JEDEC MS012-XX AS SHOWN IN ABOVE TABLE
6. N = NUMBER OF PINS



 PACKAGE FAMILY OUTLINE: SOIC .150" 1/1 21-0041 A
120 SAN GABRIEL DR. SUNNYVALE, CA 94086-1699 (415) 737-7700 DOCUMENT CONTROL NUMBER REV

Maxim cannot assume responsibility for use of any circuitry other than circuitry entirely embodied in a Maxim product. No circuit patent licenses are implied. Maxim reserves the right to change the circuitry and specifications without notice at any time.

Maxim Integrated Products, 120 San Gabriel Drive, Sunnyvale, CA 94086 408-737-7600 _____ 11

Looking for pricing, stock, or lifecycle information?

Click below to explore more details on WIN SOURCE:

-  [View MAX5917BESE+ on WIN SOURCE](#)
-  [Maxim Integrated Information](#)

Optimize Your Supply Chain with WIN SOURCE Solutions

-  Global Sourcing Solution
-  Obsolete Management
-  Cost Control Management
-  Shortage Management
-  Alternative Solution
-  Excess Inventory Management