



**THE DATASHEET OF  
MAX6468XS26D1+T**



## General Description

The MAX6467/MAX6468 microprocessor ( $\mu\text{P}$ ) supervisory circuits monitor single power-supply voltages from +1.8V to +5.0V and assert a reset if the supply voltage drops below its preset threshold. An edge-triggered, one-shot manual reset function ensures that the  $\mu\text{P}$  enters the reset mode for a fixed timeout period only, even in the event of a continuously asserted manual reset. The MAX6467/MAX6468 significantly improve system reliability compared to traditional manual reset supervisory circuits.

A variety of factory-trimmed threshold options accommodate different supply voltages and tolerances, eliminating external components. The factory-set thresholds range from +1.575V to +4.625V to monitor +5.0V, +3.3V, +3.0V, +2.5V, and +1.8V supplies with various tolerances. Reset timeout periods of 150ms (min) and 1200ms (min) are available to accommodate different  $\mu\text{P}$  platforms.

A single, active-low  $\overline{\text{RESET}}$  output asserts when  $V_{\text{CC}}$  drops below its threshold or if the edge-triggered  $\overline{\text{MR}}$  asserts low.  $\overline{\text{RESET}}$  remains low for the reset timeout period after  $V_{\text{CC}}$  rises above its threshold and for a fixed, one-shot timeout period after a manual reset input falling edge.  $\overline{\text{RESET}}$  remains valid as long as  $V_{\text{CC}}$  remains above +1V. Open-drain (MAX6467) and push-pull (MAX6468) output options provide additional flexibility in the system design.

The MAX6467/MAX6468 are offered in the space-saving 4-pin SOT143 package and the ultra-small 4-pin SC70 package and are specified over the automotive (-40°C to +125°C) temperature range.

## Applications

- Cell Phones/PDAs
- Embedded Control Systems
- Industrial Equipment
- Automotive Products
- Portable/Battery-Powered Equipment
- Medical Devices
- DSL Modems
- MP3 Players
- GPS Systems
- Digital Cameras

## Features

- Precision Factory-Set Reset Threshold Voltages for +5.0V, +3.3V, +3.0V, +2.5V, and +1.8V Supplies
- Edge-Triggered Manual Reset Input with One-Shot Pulsed Reset Output
- Two Reset Timeout Period Options (150ms or 1200ms min)
- Immune to Short Voltage Transients
- Low Supply Current (3 $\mu\text{A}$  at  $V_{\text{CC}} = +1.8\text{V}$ )
- $\overline{\text{RESET}}$  Valid to  $V_{\text{CC}} = +1\text{V}$
- Active-Low Open-Drain and Push-Pull  $\overline{\text{RESET}}$  Output Options
- -40°C to +125°C Operating Temperature Range
- Small 4-Pin SC70 and SOT143 Packages
- No External Components Required
- Pin Compatible with MAX811, MAX6315, MAX6384, and MAX6386
- AEC-Q100 Qualified, Refer to Ordering Information for Specific I/V Parts

*Ordering Information appears at end of data sheet.*

## Typical Operating Circuit

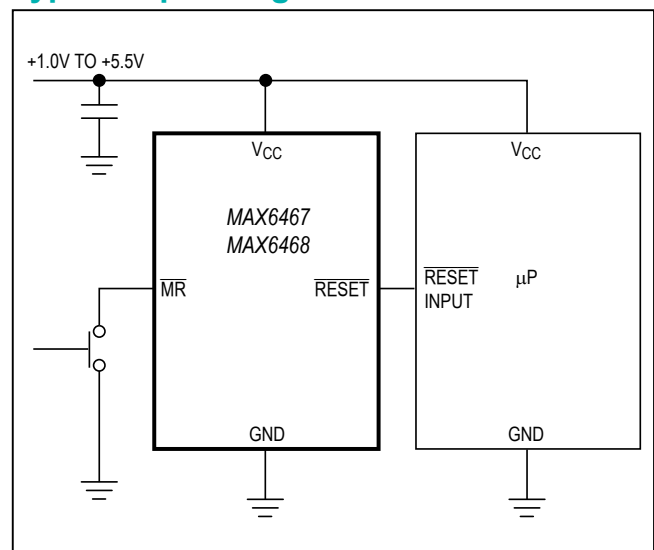

**Absolute Maximum Ratings**

V <sub>CC</sub> to GND .....	-0.3V to +6.0V	Continuous Power Dissipation (T <sub>A</sub> = +70°C)	
RESET to GND		4-Pin SC70 (derate 3.1mW/°C above +70°C).....	245mW
Open-Drain .....	-0.3V to +6.0V	4-Pin SOT143 (derate 4mW/°C above +70vC).....	320mW
Push-Pull .....	-0.3V to (V <sub>CC</sub> + 0.3V)	Operating Temperature Range.....	-40°C to +125°C
MR to GND.....	-0.3V to (V <sub>CC</sub> + 0.3V)	Storage Temperature Range.....	-65°C to +150°C
Input/Output Current (all pins).....	20mA	Junction Temperature.....	+150°C
		Lead Temperature (soldering, 10s) .....	+300°C

Stresses beyond those listed under "Absolute Maximum Ratings" may cause permanent damage to the device. These are stress ratings only, and functional operation of the device at these or any other conditions beyond those indicated in the operational sections of the specifications is not implied. Exposure to absolute maximum rating conditions for extended periods may affect device reliability.

**Electrical Characteristics**

(V<sub>CC</sub> = +1.2V to +5.5V, T<sub>A</sub> = -40°C to +125°C, unless otherwise noted. Typical values are at T<sub>A</sub> = +25°C.) (Note 1)

PARAMETER	SYMBOL	CONDITIONS	MIN	TYP	MAX	UNITS
Operating Voltage Range	V <sub>CC</sub>	T <sub>A</sub> = 0°C to +125°C	1.0		5.5	V
		T <sub>A</sub> = -40°C to 0°C	1.2		5.5	
Supply Current	I <sub>CC</sub>	V <sub>CC</sub> = +5.5V, no load		7	13	µA
		V <sub>CC</sub> = +3.6V, no load		6	11	
		V <sub>CC</sub> = +2.5V, no load		4	8	
		V <sub>CC</sub> = +1.8V, no load		3	7.5	
V <sub>CC</sub> Reset Threshold (See the Reset Threshold Table)	V <sub>TH</sub>	T <sub>A</sub> = +25°C	-1.5%	V <sub>TH</sub>	+1.5%	V
		T <sub>A</sub> = -40°C to +85°C	-2.5%		+2.5%	
		T <sub>A</sub> = +85°C to +125°C	-3%		+3%	
V <sub>CC</sub> Reset Delay	t <sub>RD</sub>	V <sub>CC</sub> falling at 10mV/µs from V <sub>TH</sub> + 100mV to V <sub>TH</sub> - 100mV		35		µs
V <sub>CC</sub> Reset Timeout Period	t <sub>RP</sub>	D3 option	150	225	300	ms
		D7 option	1200	1800	2400	
MR Timeout Period	t <sub>MRP</sub>	D3 and D7 options	150	225	300	ms
MR Rising Debounce Period (Note 2)	t <sub>DEB</sub>	D3 and D7 options	150	225	300	ms
MR Input Voltage	V <sub>IL</sub>	V <sub>TH</sub> < +4V	0.3 x V <sub>CC</sub>			V
	V <sub>IH</sub>		0.7 x V <sub>CC</sub>			
	V <sub>IL</sub>	V <sub>TH</sub> ≥ +4V	0.8			
	V <sub>IH</sub>		2.4			
MR Minimum Input Pulse			1			µs
MR Glitch Rejection				100		ns
MR to RESET Delay				200		ns
MR Pullup Resistance		MR to V <sub>CC</sub>	500	1560	3000	Ω
RESET Output High (MAX6468 Only)	V <sub>OH</sub>	V <sub>CC</sub> ≥ +2.5V, I <sub>SOURCE</sub> = 500µA, RESET not asserted	0.8 x V <sub>CC</sub>			V
		V <sub>CC</sub> ≥ +4.5V, I <sub>SOURCE</sub> = 800µA, RESET not asserted	0.8 x V <sub>CC</sub>			

Electrical Characteristics

( $V_{CC} = +1.2V$  to  $+5.5V$ ,  $T_A = -40^{\circ}C$  to  $+125^{\circ}C$ , unless otherwise noted. Typical values are at  $T_A = +25^{\circ}C$ .) (Note 1)

PARAMETER	SYMBOL	CONDITIONS	MIN	TYP	MAX	UNITS
RESET Output Low	$V_{OL}$	$V_{CC} \geq +1V$ , $I_{SINK} = 80\mu A$ , $\overline{RESET}$ asserted			0.3	V
		$V_{CC} \geq +2.5V$ , $I_{SINK} = 1.2mA$ , $\overline{RESET}$ asserted			0.3	
		$V_{CC} \geq +4.5V$ , $I_{SINK} = 3.2mA$ , $\overline{RESET}$ asserted			0.3	
RESET Output Leakage Current (MAX6467 Only)	$I_{LKG}$	$\overline{RESET}$ not asserted			1	$\mu A$

**Note 1:** Specifications over temperature are guaranteed by design. Production testing at  $T_A = +25^{\circ}C$  only.

**Note 2:** The  $\overline{MR}$  input ignores falling edges that occur within the  $\overline{MR}$  rising debounce period ( $t_{DEB}$ ) after  $\overline{MR}$  first rises from low to high (after a valid  $\overline{MR}$  reset assertion). This prevents invalid reset assertion due to switch bounce.

Typical Operating Characteristics

( $V_{CC} = +5V$ , MAX6468US29D3 device,  $T_A = +25^{\circ}C$ , unless otherwise noted.)

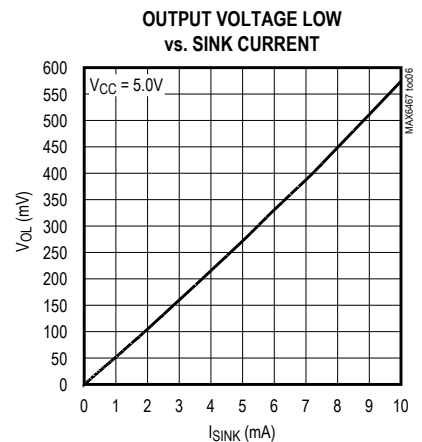
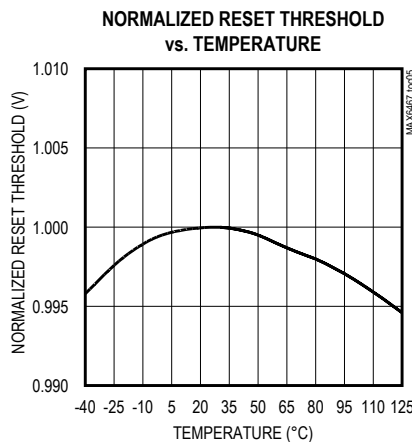
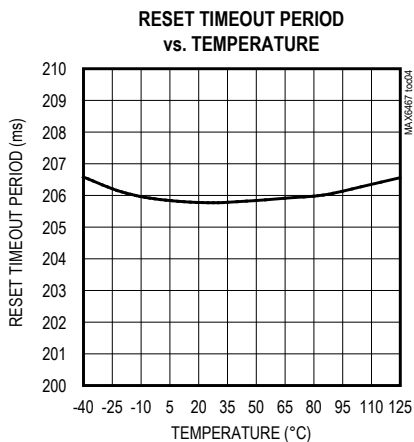
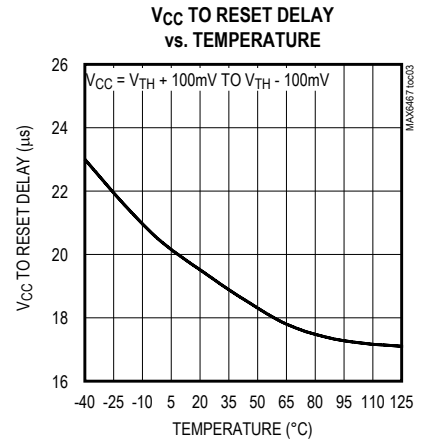
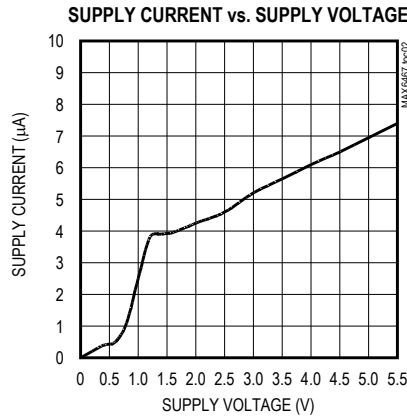
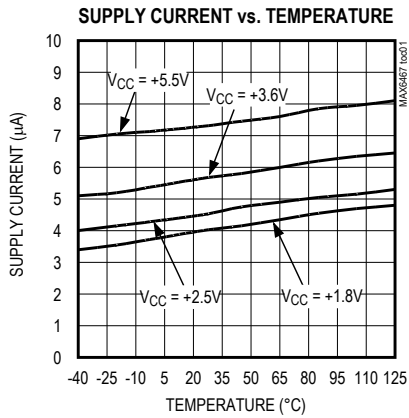

Typical Operating Characteristics

(V<sub>CC</sub> = +5V, MAX6468US29D3 device, T<sub>A</sub> = +25°C, unless otherwise noted.)

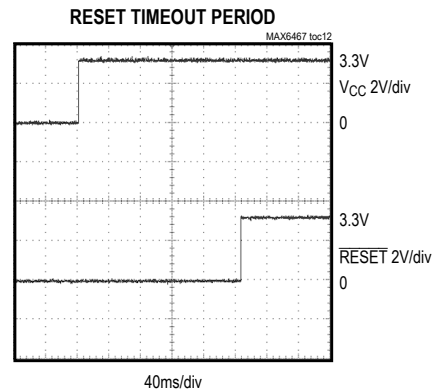
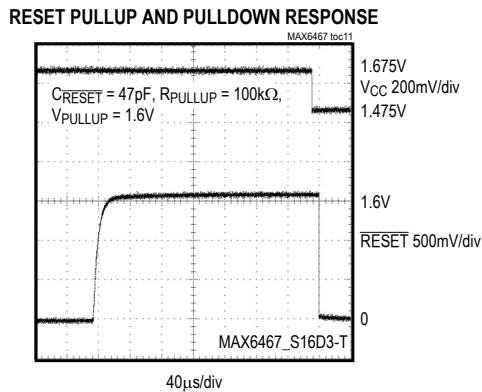
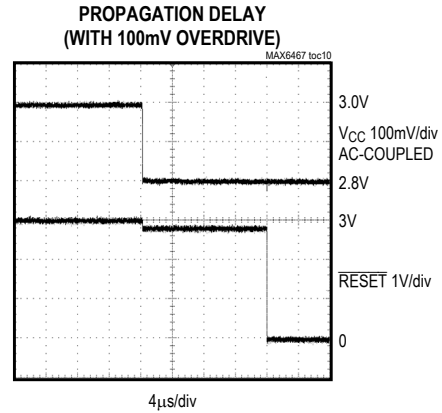
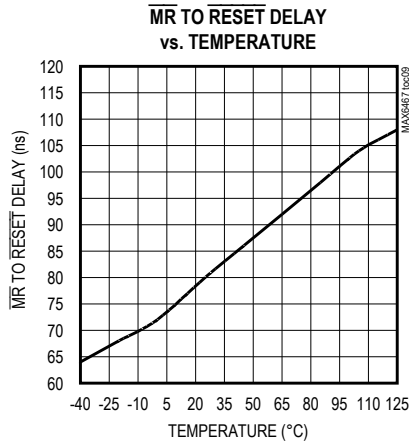
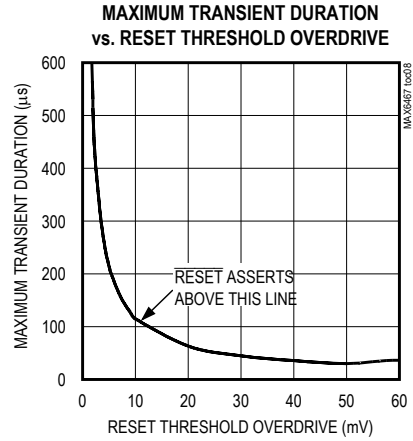
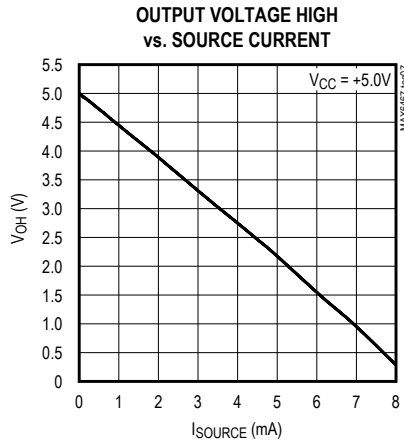

Pin Configurations

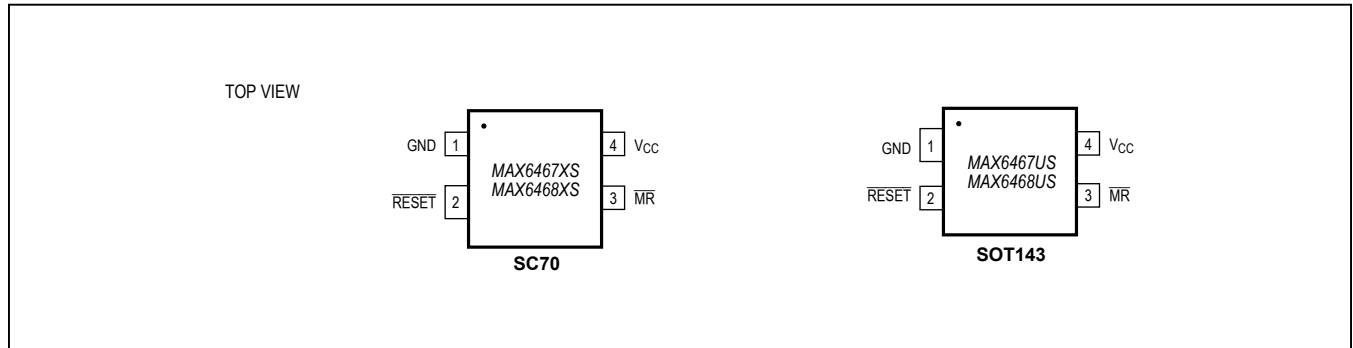

Pin Description

PIN	NAME	FUNCTION
1	GND	Ground
2	$\overline{\text{RESET}}$	Reset Output. $\overline{\text{RESET}}$ is an active-low open-drain (MAX6467) or push-pull (MAX6468) output. $\overline{\text{RESET}}$ asserts low when $V_{CC}$ drops below the selected threshold and remains low for the $V_{CC}$ reset timeout period after $V_{CC}$ rises above the threshold. The $\overline{\text{RESET}}$ one-shot asserts low for a fixed $\overline{\text{MR}}$ reset timeout period on the falling edge of the manual reset input. The open-drain output requires an external pullup resistor
3	$\overline{\text{MR}}$	Manual Reset Input. Drive $\overline{\text{MR}}$ low to initiate a reset output. $\overline{\text{MR}}$ controls an edge-triggered one-shot that asserts $\overline{\text{RESET}}$ low for a fixed $\overline{\text{MR}}$ timeout period when $\overline{\text{MR}}$ is driven low. Internal timing circuitry ignores switch close and open bounce to ensure proper one-shot reset timing
4	$V_{CC}$	Power-Supply Input. $V_{CC}$ provides power to the device and is also a monitored voltage. When $V_{CC}$ drops below the selected threshold, $\overline{\text{RESET}}$ asserts low and remains low for the reset timeout period after $V_{CC}$ rises above the threshold. For better noise immunity, bypass $V_{CC}$ to GND with a 0.1 $\mu$ F capacitor

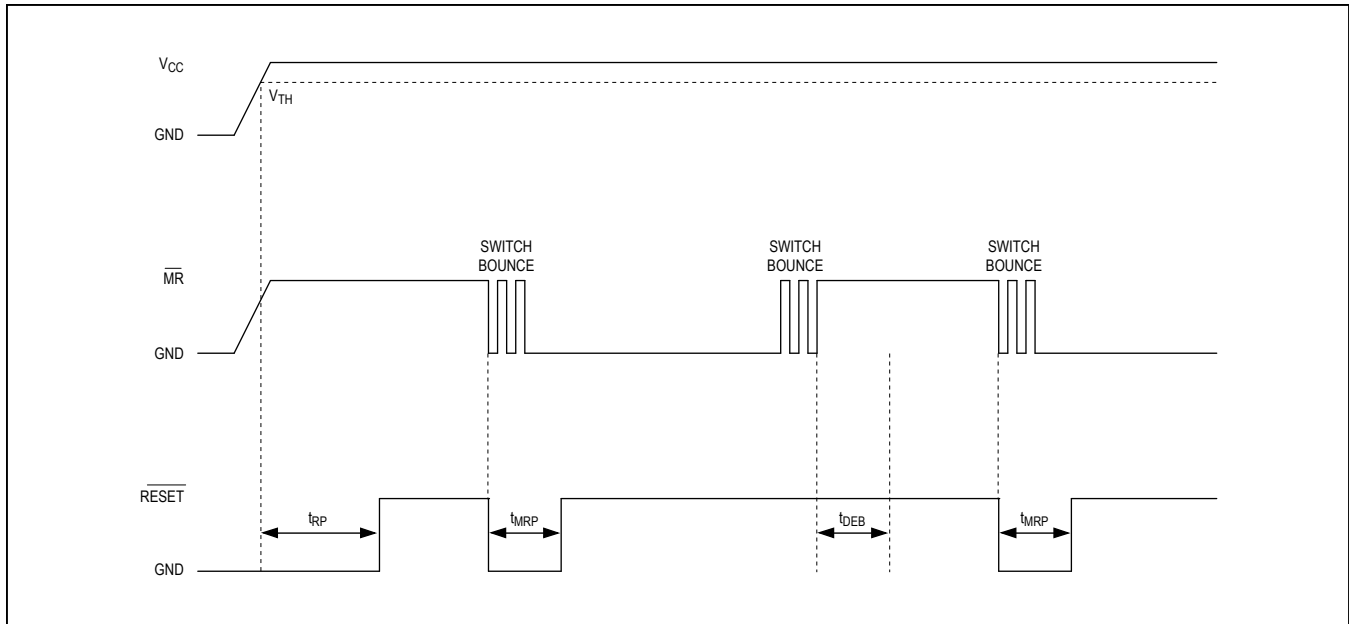

Figure 1. Timing Diagram

## Detailed Description

### Reset Output

The MAX6467 provides an active-low open-drain  $\overline{\text{RESET}}$  output. The MAX6468 provides an active-low push-pull  $\overline{\text{RESET}}$  output.  $\overline{\text{RESET}}$  asserts low if  $V_{CC}$  drops below the selected threshold or if a falling edge occurs on  $\overline{\text{MR}}$ .  $\overline{\text{RESET}}$  remains low for the  $V_{CC}$  reset timeout period after  $V_{CC}$  increases above the threshold voltage or is one-shot pulsed low for the  $\overline{\text{MR}}$  timeout period after a falling edge on  $\overline{\text{MR}}$ .

### Manual Reset Input

Many  $\mu\text{P}$ -based products require manual reset capability, allowing the operator, a test technician, or external logic circuitry to initiate a reset. A falling edge on  $\overline{\text{MR}}$  asserts

$\overline{\text{RESET}}$  low.  $\overline{\text{RESET}}$  is one-shot pulsed low for the  $\overline{\text{MR}}$  timeout period after a falling edge on  $\overline{\text{MR}}$ . An internal 1.5k $\Omega$  pullup resistor to  $V_{CC}$  allows MR to be left unconnected if not used.  $\overline{\text{MR}}$  can be driven with TTL or CMOS-logic levels, or with open-drain/collector outputs. Connect a normally open momentary pushbutton switch from  $\overline{\text{MR}}$  to GND to realize a manual reset function. External debounce circuitry is not required, as the MAX6467/MAX6468 respond to the first falling edge on  $\overline{\text{MR}}$  and ignore subsequent falling edges within the reset timeout period and during the  $\overline{\text{MR}}$  debounce period (see Figure 1). After  $\overline{\text{MR}}$  goes high for 150ms ( $t_{\text{DEB}}$ ), the manual reset one-shot is ready to trigger a reset on the next  $\overline{\text{MR}}$  falling edge. Connect a 0.1 $\mu\text{F}$  capacitor from  $\overline{\text{MR}}$  to GND when using long cables to provide additional noise immunity (Figure 2).

Reset Timeout Delay\*

RESET TIMEOUT SUFFIX	V <sub>CC</sub> RESET TIMEOUT PERIOD (min/max) (ms)	MR TIMEOUT PERIOD (min/max) (ms)	MR RISING DEBOUNCE PERIOD (min/max) (ms)
D3	150/300	150/300	150/300
D7	1200/2400	150/300	150/300

\*Additional reset timeout options may be available. Contact factory for availability.

Applications Information

Falling V<sub>CC</sub> Transients

In addition to issuing a reset to the μP during power-up, power-down, and brownout conditions, the MAX6467/MAX6468 are relatively immune to short-duration falling V<sub>CC</sub> transients (glitches). The Typical Operating Characteristics section shows the Maximum Transient Duration vs. V<sub>CC</sub> Overdrive for which the MAX6467/MAX6468 do not generate a reset pulse. This graph was generated using a falling pulse applied to V<sub>CC</sub> starting above the actual reset threshold and ending below the threshold by the magnitude indicated (V<sub>CC</sub> Overdrive). The graph indicates the typical maximum pulse width a falling V<sub>CC</sub> transient can have without initiating a reset pulse. As the magnitude of the transient increases (goes

farther below the reset threshold), the maximum allowable pulse width decreases. A 0.1μF bypass capacitor from V<sub>CC</sub> to GND provides additional transient immunity.

Ensuring a Valid RESET Output Down to V<sub>CC</sub> = 0V

The MAX6467/MAX6468 guarantee proper operation down to V<sub>CC</sub> = +1V. In applications that require valid reset levels down to V<sub>CC</sub> = 0V, a pulldown resistor to active-low outputs (MAX6468 only, Figure 3) ensures that  $\overline{\text{RESET}}$  remains valid while the  $\overline{\text{RESET}}$  output can no longer sink current. This scheme does not work with the open-drain outputs of the MAX6467. Ensure that the resistor value used does not overload the  $\overline{\text{RESET}}$  output when V<sub>CC</sub> is above the reset threshold. For most applications, use 100kΩ to 1MΩ.

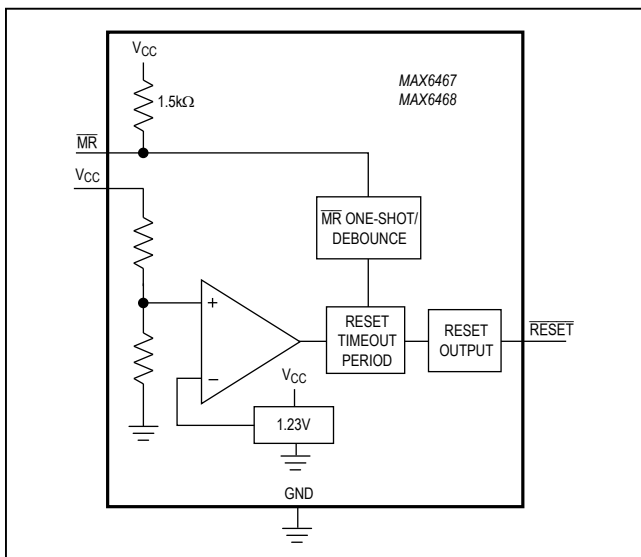

Figure 2. Functional Diagram

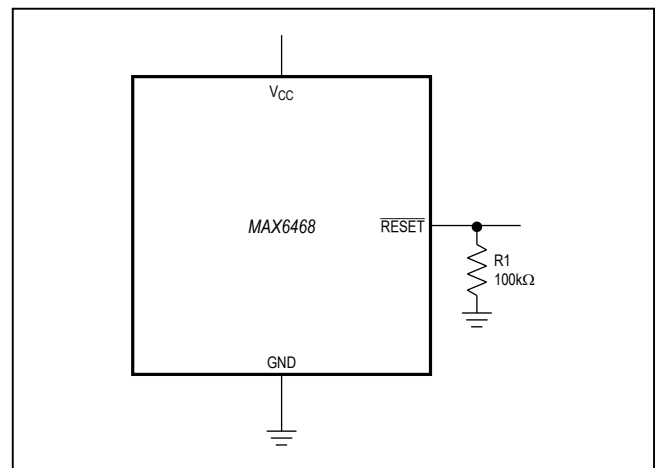

Figure 3.  $\overline{\text{RESET}}$  Valid to V<sub>CC</sub> = 0V

Chip Information

TRANSISTOR COUNT: 748

PROCESS: BICMOS

## Standard Versions

PART	TOP MARK
<b>MAX6467</b> XS16D3	AGL
MAX6467XS22D3	AGM
MAX6467XS26D3	AGN
MAX6467XS29D3	AGO
MAX6467XS46D3	AGP
MAX6467US16D3	KAFN
MAX6467US22D3	KAFO
MAX6467US26D3	KAFP
MAX6467US29D3	KAFQ
MAX6467US46D3	KAFR
<b>MAX6468</b> XS16D3	AGQ
MAX6468XS22D3	AGR
MAX6468XS26D3	AGS
MAX6468XS29D3	AGC
MAX6468XS46D3	AGB
MAX6468US16D3	KAFS
MAX6468US22D3	KAFT
MAX6468US26D3	KAFU
MAX6468US29D3	KAEW
MAX6468US46D3	KAFV

## Reset Threshold (-40°C to +85°C)

SUFFIX	V <sub>TH</sub> (min)	V <sub>TH</sub> (typ)	V <sub>TH</sub> (max)
46	4.509	4.625	4.741
45	4.388	4.500	4.613
44	4.266	4.375	4.484
43	4.193	4.300	4.408
42	4.095	4.200	4.305
41	3.998	4.100	4.203
40	3.900	4.000	4.100
39	3.803	3.900	3.998
38	3.705	3.800	3.895
37	3.608	3.700	3.793
36	3.510	3.600	3.690
35	3.413	3.500	3.588
34	3.315	3.400	3.485
33	3.218	3.300	3.383
32	3.120	3.200	3.280
31	2.998	3.075	3.152
30	2.925	3.000	3.075
29	2.852	2.925	2.998
28	2.730	2.800	2.870
27	2.633	2.700	2.768
26	2.559	2.625	2.691
25	2.438	2.500	2.563
24	2.340	2.400	2.460
23	2.255	2.313	2.370
22	2.133	2.188	2.242
21	2.048	2.100	2.153
20	1.950	2.000	2.050
19	1.853	1.900	1.948
18	1.755	1.800	1.845
17	1.623	1.665	1.707
16	1.536	1.575	1.614

**Ordering Information**

PART	TEMP RANGE	PIN-PACKAGE
<b>MAX6467</b> XS__D_-T	-40°C to +125°C	4 SC70-4
MAX6467XS__D_/V+T*	-40°C to +125°C	4 SC70-4
MAX6467XS29D3/V+T	-40°C to +125°C	4 SC70-4
MAX6467XS32D3/V+T	-40°C to +125°C	4 SC70-4
MAX6467US__D_-T	-40°C to +125°C	4 SOT143-4
<b>MAX6468</b> XS__D_-T	-40°C to +125°C	4 SC70-4
MAX6468US__D_-T	-40°C to +125°C	4 SOT143-4

**Note:** Insert reset threshold suffix (see Reset Threshold table) after XS or US. Insert reset timeout delay (see Reset Timeout Delay table) after D to complete the part number. Sample stock is generally held on standard versions only (see Standard Versions table). Standard versions have an order increment requirement of 2500 pieces. Nonstandard versions have an order increment requirement of 10,000 pieces. Contact factory for availability. Devices are available in both leaded and lead-free packaging. Specify lead-free by replacing “T” with “+T” when ordering.

T = Tape and reel.  
 /V denotes an automotive qualified part.  
 +Denotes a lead(pb)-free/RoHS-compliant package.  
 \*Future product—contact factory for availability.

**Package Information**

For the latest package outline information and land patterns (footprints), go to [www.maximintegrated.com/packages](http://www.maximintegrated.com/packages). Note that a “+”, “#”, or “-” in the package code indicates RoHS status only. Package drawings may show a different suffix character, but the drawing pertains to the package regardless of RoHS status.

PACKAGE TYPE	PACKAGE CODE	OUTLINE NO.	LAND PATTERN NO.
4 SC70	X4+1	21-0098	90-0187
4 SOT143	U3+1	21-0052	90-0183

## Revision History

REVISION NUMBER	REVISION DATE	DESCRIPTION	PAGES CHANGED
2	3/14	Added <i>I</i> V OPNs	1
3	4/14	Removed automotive reference from <i>Applications</i> section	1
	6/14	Reversed 4/14 change and added automotive reference back to <i>Applications</i> section	1
4	10/14	Fixed typo in <i>Package Information</i> section	9
5	10/15	Fixed MR Pullup Resistance specification in <i>Electrical Characteristics</i> table	2
6	3/18	Updated <i>Benefits and Features</i> and <i>Ordering Information</i> table	1, 9

For pricing, delivery, and ordering information, please contact Maxim Direct at 1-888-629-4642, or visit Maxim Integrated's website at [www.maximintegrated.com](http://www.maximintegrated.com).

Maxim Integrated cannot assume responsibility for use of any circuitry other than circuitry entirely embodied in a Maxim Integrated product. No circuit patent licenses are implied. Maxim Integrated reserves the right to change the circuitry and specifications without notice at any time. The parametric values (min and max limits) shown in the *Electrical Characteristics* table are guaranteed. Other parametric values quoted in this data sheet are provided for guidance.

## Looking for pricing, stock, or lifecycle information?

Click below to explore more details on WIN SOURCE:

- ⊖ [View MAX6468XS26D1+T on WIN SOURCE](#)
- ⊖ [Maxim Integrated Information](#)

## Optimize Your Supply Chain with WIN SOURCE Solutions

- ✓ Global Sourcing Solution
- ✓ Obsolete Management
- ✓ Cost Control Management
- ✓ Shortage Management
- ✓ Alternative Solution
- ✓ Excess Inventory Management