



**THE DATASHEET OF  
MAX6719AUTTGD3+T**



# MAX6715A–MAX6729A/ MAX6797A

# Dual/Triple, Ultra-Low-Voltage, SOT23 $\mu$ P Supervisory Circuits

## General Description

The MAX6715A–MAX6729A/MAX6797A are ultra-low-voltage microprocessor ( $\mu$ P) supervisory circuits designed to monitor two or three system power-supply voltages. These devices assert a system reset if any monitored supply falls below its factory-trimmed or adjustable threshold and maintain reset for a minimum timeout period after all supplies rise above their thresholds. The integrated dual/triple supervisory circuits significantly improve system reliability and reduce size compared to separate ICs or discrete components.

These devices monitor primary supply voltages ( $V_{CC1}$ ) from 1.8V to 5.0V and secondary supply voltages ( $V_{CC2}$ ) from 0.9V to 3.3V with factory-trimmed reset threshold voltage options (see the *Reset Voltage Threshold Suffix Guide*). An externally adjustable RSTIN input option allows customers to monitor a third supply voltage down to 0.62V. These devices are guaranteed to be in the correct reset output logic state when either  $V_{CC1}$  or  $V_{CC2}$  remains greater than 0.8V.

A variety of push-pull or open-drain reset outputs along with watchdog input, manual-reset input, and power-fail input/output features are available (see the Selector Guide). Select reset timeout periods from 1.1ms to 1120ms (min) (see the *Reset Timeout Period Suffix Guide*). The MAX6715A–MAX6729A/MAX6797A are available in small 5-, 6-, and 8-pin SOT23 packages and operate over the  $-40^{\circ}\text{C}$  to  $+125^{\circ}\text{C}$  temperature range.

## Applications

- Multivoltage Systems
- Telecom/Networking Equipment
- Computers/Servers
- Portable/Battery-Operated Equipment
- Industrial Equipment
- Printers/Fax Machines
- Set-Top Boxes

## Features

- $V_{CC1}$  (Primary Supply) Reset Threshold Voltages from 1.58V to 4.63V
- $V_{CC2}$  (Secondary Supply) Reset Threshold Voltages from 0.79V to 3.08V
- Externally Adjustable RSTIN Threshold for Auxiliary/ Triple-Voltage Monitoring (0.62V Internal Reference)
- Watchdog Timer Option
  - 35s (min) Long Startup Period
  - 1.12s (min) Normal Timeout Period
- Manual-Reset Input Option
- Power-Fail Input/Power-Fail Output Option (Push-Pull and Open-Drain Active-Low)
- Guaranteed Reset Valid Down to  $V_{CC1}$  or  $V_{CC2} = 0.8\text{V}$
- Reset Output Logic Options
- Immune to Short  $V_{CC}$  Transients
- Low Supply Current 14 $\mu\text{A}$  (typ) at 3.6V
- Watchdog Disable Feature
- Small 5, 6, and 8-Pin SOT23 Packages
- AEC-Q100 Qualified: MAX6719AUTCWD1/V+T

*Ordering Information continued at end of data sheet.*

*Pin Description and Selector Guide appear at end of data sheet.*

## Typical Operating Circuit

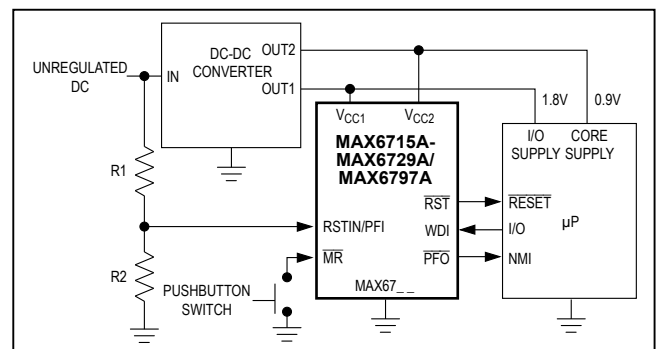

### Absolute Maximum Ratings

Terminal Voltage (with respect to GND)

$V_{CC1}$ , $V_{CC2}$ .....	-0.3V to +6V
Open-Drain $\overline{RST}$ , $\overline{RST1}$ , $\overline{RST2}$ , $\overline{PFO}$ , $\overline{RST}$ .....	-0.3V to +6V
Push-Pull $\overline{RST}$ , $\overline{RST1}$ , $\overline{PFO}$ , $\overline{RST}$ .....	-0.3V to ( $V_{CC1} + 0.3V$ )
Push-Pull $\overline{RST2}$ .....	-0.3V to ( $V_{CC2} + 0.3V$ )
$\overline{RSTIN}$ , $\overline{PFI}$ , $\overline{MR}$ , $\overline{WDI}$ .....	-0.3V to +6V
Input Current/Output Current (all pins) .....	20mA

Continuous Power Dissipation ( $T_A = +70^\circ\text{C}$ )

5-Pin SOT23-5 (derate 7.1mW/ $^\circ\text{C}$ above $+70^\circ\text{C}$ ) .....	571mW
6-Pin SOT23-6 (derate 8.7mW/ $^\circ\text{C}$ above $+70^\circ\text{C}$ ) .....	696mW
8-Pin SOT23-8 (derate 8.9mW/ $^\circ\text{C}$ above $+70^\circ\text{C}$ ) .....	714mW
Operating Temperature Range .....	$-40^\circ\text{C}$ to $+125^\circ\text{C}$
Storage Temperature Range .....	$-65^\circ\text{C}$ to $+150^\circ\text{C}$
Junction Temperature .....	$+150^\circ\text{C}$
Lead Temperature (soldering, 10s) .....	$+300^\circ\text{C}$

Stresses beyond those listed under "Absolute Maximum Ratings" may cause permanent damage to the device. These are stress ratings only, and functional operation of the device at these or any other conditions beyond those indicated in the operational sections of the specifications is not implied. Exposure to absolute maximum rating conditions for extended periods may affect device reliability.

### Electrical Characteristics

( $V_{CC1} = 0.8V$  to  $5.5V$ ,  $V_{CC2} = 0.8V$  to  $5.5V$ ,  $\text{GND} = 0V$ ,  $T_A = -40^\circ\text{C}$  to  $+125^\circ\text{C}$ , unless otherwise noted. Typical values are at  $T_A = +25^\circ\text{C}$ .) (Note 1)

PARAMETER	SYMBOL	CONDITIONS	MIN	TYP	MAX	UNITS
Supply Voltage	$V_{CC}$		0.8		5.5	V
Supply Current	$I_{CC1}$	$V_{CC1} < 5.5V$ all I/O connections open, outputs not asserted		15	39	$\mu\text{A}$
		$V_{CC1} < 3.6V$ all I/O connections open, outputs not asserted		10	28	
	$I_{CC2}$	$V_{CC2} < 3.6V$ all I/O connections open, outputs not asserted		4	11	
		$V_{CC2} < 2.75V$ all I/O connections open, outputs not asserted		3	9	
$V_{CC1}$ Reset Threshold	$V_{TH1}$	L (falling)	4.500	4.625	4.750	V
		M (falling)	4.250	4.375	4.500	
		T (falling)	3.000	3.075	3.150	
		S (falling)	2.850	2.925	3.000	
		R (falling)	2.550	2.625	2.700	
		Z (falling)	2.250	2.313	2.375	
		Y (falling)	2.125	2.188	2.250	
		W (falling)	1.620	1.665	1.710	
$V_{CC2}$ Reset Threshold	$V_{TH2}$	V (falling)	1.530	1.575	1.620	V
		I (falling)	1.350	1.388	1.425	
		H (falling)	1.275	1.313	1.350	
		G (falling)	1.080	1.110	1.140	
		F (falling)	1.020	1.050	1.080	
		E (falling)	0.810	0.833	0.855	
		D (falling)	0.765	0.788	0.810	
		T (falling)	3.000	3.075	3.150	
		S (falling)	2.850	2.925	3.000	
		R (falling)	2.550	2.625	2.700	
		Z (falling)	2.250	2.313	2.375	
		Y (falling)	2.125	2.188	2.250	
		W (falling)	1.620	1.665	1.710	

### Electrical Characteristics (continued)

( $V_{CC1} = 0.8V$  to  $5.5V$ ,  $V_{CC2} = 0.8V$  to  $5.5V$ ,  $GND = 0V$ ,  $T_A = -40^\circ C$  to  $+125^\circ C$ , unless otherwise noted. Typical values are at  $T_A = +25^\circ C$ .) (Note 1)

PARAMETER	SYMBOL	CONDITIONS	MIN	TYP	MAX	UNITS
Reset Threshold Tempco	$\Delta V_{TH}/^\circ C$			20		ppm/ $^\circ C$
Reset Threshold Hysteresis	$V_{HYST}$	Referenced to $V_{TH}$ typical		0.5		%
$V_{CC}$ to Reset Output Delay	$t_{RD}$	$V_{CC1} = (V_{TH1} + 100mV)$ to $(V_{TH1} - 100mV)$ or $V_{CC2} = (V_{TH2} + 75mV)$ to $(V_{TH2} - 75mV)$		20		$\mu s$
Reset Timeout Period	$t_{RP}$	D1	1.1	1.65	2.2	ms
		D2	8.8	13.2	17.6	
		D7 (MAX6797A only)	17.5	26.25	35	
		D8 (MAX6797A only)	35	52.5	70	
		D3	140	210	280	
		D5	280	420	560	
		D6	560	840	1120	
D4	1120	1680	2240			
<b>ADJUSTABLE RESET COMPARATOR INPUT (MAX6719A/MAX6720A/MAX6723A–MAX6727A)</b>						
RSTIN Input Threshold	$V_{RSTIN}$		611	626.5	642	mV
RSTIN Input Current	$I_{RSTIN}$		-100		+100	nA
RSTIN Hysteresis				3		mV
RSTIN to Reset Output Delay	$t_{RSTIND}$	$V_{RSTIN}$ to $(V_{RSTIN} - 30mV)$		22		$\mu s$
<b>POWER-FAIL INPUT (MAX6728A/MAX6729A)</b>						
PFI Input Threshold	$V_{PFI}$		611	626.5	642	mV
PFI Input Current	$I_{PFI}$		-100		+100	nA
PFI Hysteresis	$V_{PFIH}$			3		mV
PFI to $P\bar{F}O$ Delay	$t_{DPF}$	$(V_{PFI} + 30mV)$ to $(V_{PFI} - 30mV)$		2		$\mu s$
<b>MANUAL-RESET INPUT (MAX6715A–MAX6722A/MAX6725A–MAX6729A)</b>						
$\overline{MR}$ Input Voltage	$V_{IL}$			$0.3 \times V_{CC1}$		V
	$V_{IH}$		$0.7 \times V_{CC1}$			
$\overline{MR}$ Minimum Pulse Width			1			$\mu s$
$\overline{MR}$ Glitch Rejection				100		ns
$\overline{MR}$ to Reset Delay	$t_{MR}$			200		ns
$\overline{MR}$ Pullup Resistance			25	50	80	k $\Omega$
<b>WATCHDOG INPUT (MAX6721A–MAX6729A)</b>						
Watchdog Timeout Period	$t_{WD}$	First watchdog period after reset timeout period	35	54	72	s
		Normal mode	1.12	1.68	2.24	
WDI Pulse Width	$t_{WDI}$	(Note 2)	50			ns
WDI Input Voltage	$V_{IL}$		$0.3 \times V_{CC1}$		V	
	$V_{IH}$		$0.7 \times V_{CC1}$			
WDI Input Current	$I_{WDI}$	$V_{WDI} = 0V$ or $V_{CC1}$	-1		+1	$\mu A$

### Electrical Characteristics (continued)

( $V_{CC1} = 0.8V$  to  $5.5V$ ,  $V_{CC2} = 0.8V$  to  $5.5V$ ,  $GND = 0V$ ,  $T_A = -40^{\circ}C$  to  $+125^{\circ}C$ , unless otherwise noted. Typical values are at  $T_A = +25^{\circ}C$ .) (Note 1)

PARAMETER	SYMBOL	CONDITIONS	MIN	TYP	MAX	UNITS
<b>RESET/POWER-FAIL OUTPUTS</b>						
$\overline{RST}/RST1/RST2/PF\overline{O}$ Output Low (Push-Pull or Open-Drain)	$V_{OL}$	$V_{CC1}$ or $V_{CC2} \geq 0.8V$ , $I_{SINK} = 1\mu A$ , output asserted			0.3	V
		$V_{CC1}$ or $V_{CC2} \geq 1.0V$ , $I_{SINK} = 50\mu A$ , output asserted			0.3	
		$V_{CC1}$ or $V_{CC2} \geq 1.2V$ , $I_{SINK} = 100\mu A$ , output asserted			0.3	
		$V_{CC1}$ or $V_{CC2} \geq 2.7V$ , $I_{SINK} = 1.2mA$ , output asserted			0.3	
		$V_{CC1}$ or $V_{CC2} \geq 4.5V$ , $I_{SINK} = 3.2mA$ , output asserted			0.4	
$\overline{RST}/RST1/PF\overline{O}$ Output High (Push-Pull Only)	$V_{OH}$	$V_{CC1} \geq 1.8V$ , $I_{SOURCE} = 200\mu A$ , output not asserted	$0.8 \times V_{CC1}$			V
		$V_{CC1} \geq 2.7V$ , $I_{SOURCE} = 500\mu A$ , output not asserted	$0.8 \times V_{CC1}$			
		$V_{CC1} \geq 4.5V$ , $I_{SOURCE} = 800\mu A$ , output not asserted	$0.8 \times V_{CC1}$			
$\overline{RST}2$ Output High (Push-Pull Only)	$V_{OH}$	$V_{CC1} \geq 1.8V$ , $I_{SOURCE} = 200\mu A$ , output not asserted	$0.8 \times V_{CC2}$			V
		$V_{CC1} \geq 2.7V$ , $I_{SOURCE} = 500\mu A$ , output not asserted	$0.8 \times V_{CC2}$			
		$V_{CC1} \geq 4.5V$ , $I_{SOURCE} = 800\mu A$ , output not asserted	$0.8 \times V_{CC2}$			
RST Output High (Push-Pull Only)	$V_{OH}$	$V_{CC1} \geq 1.0V$ , $I_{SOURCE} = 1\mu A$ , reset asserted	$0.8 \times V_{CC1}$			V
		$V_{CC1} \geq 1.8V$ , $I_{SOURCE} = 150\mu A$ , reset asserted	$0.8 \times V_{CC1}$			
		$V_{CC1} \geq 2.7V$ , $I_{SOURCE} = 500\mu A$ , reset asserted	$0.8 \times V_{CC1}$			
		$V_{CC1} \geq 4.5V$ , $I_{SOURCE} = 800\mu A$ , reset asserted	$0.8 \times V_{CC1}$			
RST Output Low (Push-Pull or Open Drain)	$V_{OL}$	$V_{CC1}$ or $V_{CC2} \geq 1.8V$ , $I_{SINK} = 500\mu A$ , reset not asserted			0.3	V
		$V_{CC1}$ or $V_{CC2} \geq 2.7V$ , $I_{SINK} = 1.2mA$ , reset not asserted			0.3	
		$V_{CC1}$ or $V_{CC2} \geq 4.5V$ , $I_{SINK} = 3.2mA$ , reset not asserted			0.4	
RST/RST1/RST2/PF $\overline{O}$ Output Open-Drain Leakage Current		Output not asserted			0.5	$\mu A$
RST Output Open-Drain Leakage Current		Output asserted			0.5	$\mu A$

**Note 1:** Devices tested at  $T_A = +25^{\circ}C$ . Overtemperature limits are guaranteed by design and not production tested.

**Note 2:** Parameter guaranteed by design.

Typical Operating Characteristics

( $V_{CC1} = 5\text{V}$ ,  $V_{CC2} = 3.3\text{V}$ ,  $T_A = +25^\circ\text{C}$ , unless otherwise noted.)

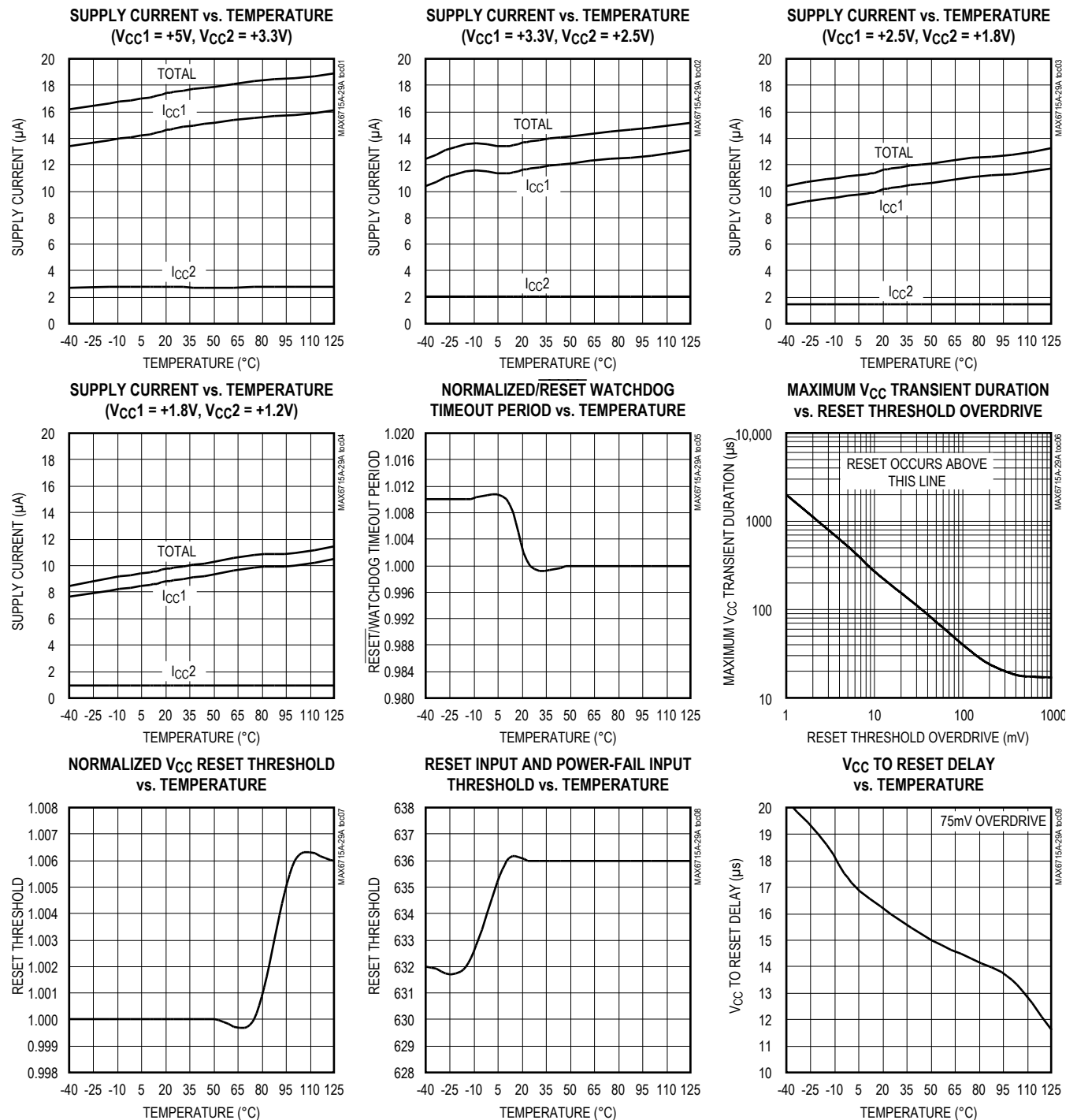

### Typical Operating Characteristics (continued)

( $V_{CC1} = 5V$ ,  $V_{CC2} = 3.3V$ ,  $T_A = +25^\circ C$ , unless otherwise noted.)

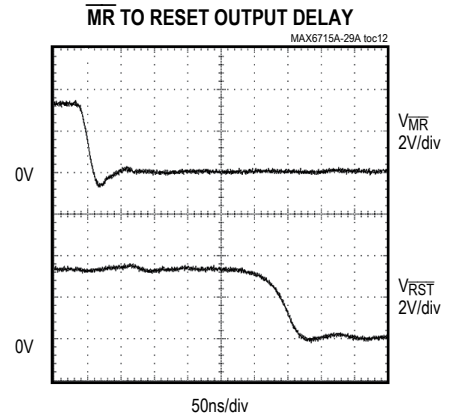
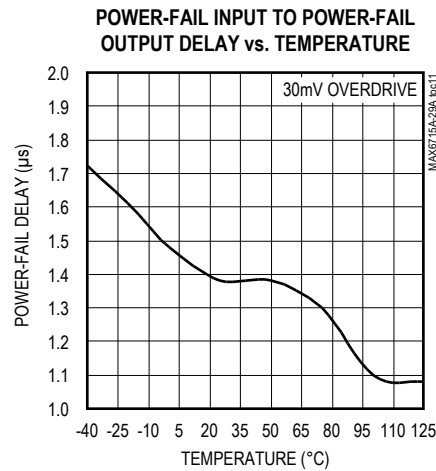
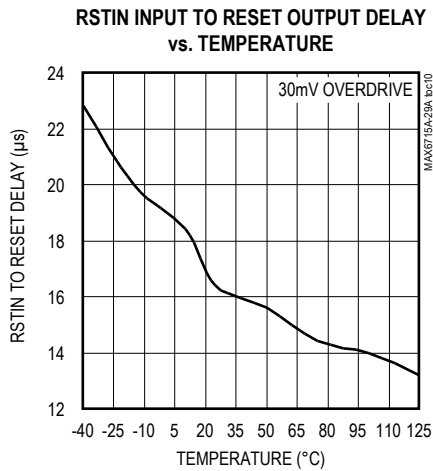

### Pin Description

PIN								NAME	FUNCTION
MAX6715A/ MAX6716A	MAX6717A/ MAX6718A	MAX6719A/ MAX6720A	MAX6721A/ MAX6722A	MAX6723A/ MAX6724A	MAX6725A/ MAX6726A	MAX6727A	MAX6728A/ MAX6729A/ MAX6797A		
1	1	1	1	1	1	1, 4	1	$\overline{RST}/$ $\overline{RST1}$	Active-Low Reset Output, Open-Drain or Push-Pull. $\overline{RST}/\overline{RST1}$ changes from high to low when $V_{CC1}$ or $V_{CC2}$ drops below the selected reset thresholds, $RSTIN$ is below threshold, $\overline{MR}$ is pulled low, or the watchdog triggers a reset. $\overline{RST}/\overline{RST1}$ remains low for the reset timeout period after $V_{CC1}/V_{CC2}/RSTIN$ exceed the device reset thresholds, $\overline{MR}$ goes low to high, or the watchdog triggers a reset. Open-drain outputs require an external pullup resistor. Push-pull outputs are referenced to $V_{CC1}$ .

Pin Description (continued)

PIN								NAME	FUNCTION
MAX6715A/ MAX6716A	MAX6717A/ MAX6718A	MAX6719A/ MAX6720A	MAX6721A/ MAX6722A	MAX6723A/ MAX6724A	MAX6725A/ MAX6726A	MAX6727A	MAX6728A/ MAX6729A/ MAX6797A		
5	—	—	—	—	—	—	—	$\overline{\text{RST2}}$	Active-Low Reset Output, Open-Drain or Push-Pull. $\overline{\text{RST2}}$ changes from high to low when $V_{\text{CC1}}$ or $V_{\text{CC2}}$ drops below the selected reset thresholds or $\overline{\text{MR}}$ is pulled low. $\overline{\text{RST2}}$ remains low for the reset timeout period after $V_{\text{CC1}}/V_{\text{CC2}}$ exceed the device reset thresholds or $\overline{\text{MR}}$ goes low to high. Open-drain outputs require an external pullup resistor. Push-pull outputs are referenced to $V_{\text{CC2}}$ .
2	2	2	2	2	2	2	2	GND	Ground
3	3	3	3	—	5	5	5	$\overline{\text{MR}}$	Active-Low Manual-Reset Input. Internal 50k $\Omega$ pullup to $V_{\text{CC1}}$ . Pull low to force a reset. Reset remains active as long as $\overline{\text{MR}}$ is low and for the reset timeout period after $\overline{\text{MR}}$ goes high. Leave unconnected or connect to $V_{\text{CC1}}$ if unused.
4	4	4	4	4	6	6	6	$V_{\text{CC2}}$	Secondary Supply Voltage Input. Powers the device when it is above $V_{\text{CC1}}$ and input for secondary reset threshold monitor.
6	5	6	6	6	8	8	8	$V_{\text{CC1}}$	Primary Supply Voltage Input. Powers the device when it is above $V_{\text{CC2}}$ and input for primary reset threshold monitor.

Pin Description (continued)

PIN								NAME	FUNCTION
MAX6715A/ MAX6716A	MAX6717A/ MAX6718A	MAX6719A/ MAX6720A	MAX6721A/ MAX6722A	MAX6723A/ MAX6724A	MAX6725A/ MAX6726A	MAX6727A	MAX6728A/ MAX6729A/ MAX6797A		
—	—	—	5	3	3	3	3	WDI	<p>Watchdog Input. If WDI remains high or low for longer than the watchdog timeout period, the internal watchdog timer runs out and the reset output asserts for the reset timeout period. The internal watchdog timer clears whenever a reset is asserted or WDI sees a rising or falling edge. The watchdog has a long startup period (35s min) after each reset event and a short watchdog timeout period (1.12s min) after the first valid WDI transition. Leave WDI unconnected to disable the watchdog timer. The WDI unconnected-state detector uses a small 200nA current source. Therefore, do not connect WDI to anything that will source more than 50nA.</p>
—	—	5	—	5	7	7	—	RSTIN	<p>Undervoltage Reset Comparator Input. High-impedance input for adjustable reset monitor. The reset output is asserted when RSTIN falls below the 0.626V internal reference voltage. Set the monitored voltage reset threshold with an external resistor-divider network. Connect RSTIN to <math>V_{CC1}</math> or <math>V_{CC2}</math> if not used.</p>

Pin Description (continued)

PIN								NAME	FUNCTION
MAX6715A/ MAX6716A	MAX6717A/ MAX6718A	MAX6719A/ MAX6720A	MAX6721A/ MAX6722A	MAX6723A/ MAX6724A	MAX6725A/ MAX6726A	MAX6727A	MAX6728A/ MAX6729A/ MAX6797A		
—	—	—	—	—	—	—	7	PFI	Power-Fail Voltage Monitor Input. High-impedance input for internal power-fail monitor comparator. Connect PFI to an external resistor-divider network to set the power-fail threshold voltage (0.626V typical internal reference voltage). Connect to GND, $V_{CC1}$ , or $V_{CC2}$ if not used.
—	—	—	—	—	—	—	4	$\overline{\text{PFO}}$	Active-Low Power-Fail Monitor Output, Open-Drain or Push-Pull. $\overline{\text{PFO}}$ is asserted low when PFI is less than 0.626V. $\overline{\text{PFO}}$ deasserts without a reset timeout period. Open-drain outputs require an external pullup resistor. Push-pull outputs are referenced to $V_{CC1}$ .
—	—	—	—	—	4	—	—	RST	Active-High Reset Output, Open-Drain or Push-Pull. RST changes from low to high when $V_{CC1}$ or $V_{CC2}$ drops below selected reset thresholds, RSTIN is below threshold, $\overline{\text{MR}}$ is pulled low, or the watchdog triggers a reset. RST remains HIGH for the reset timeout period after $V_{CC1}/V_{CC2}/\text{RSTIN}$ exceed the device reset thresholds, $\overline{\text{MR}}$ goes low to high, or the watchdog triggers a reset. Open-drain outputs require an external pullup resistor. Push-pull outputs are referenced to $V_{CC1}$ .

## Detailed Description

### Supply Voltages

The MAX6715A–MAX6729A/MAX6797A  $\mu$ P supervisory circuits maintain system integrity by alerting the  $\mu$ P to fault conditions. These ICs are optimized for systems that monitor two or three supply voltages. The output reset state is guaranteed to remain valid while either  $V_{CC1}$  or  $V_{CC2}$  is above 0.8V.

### Threshold Levels

Input-voltage threshold level combinations are indicated by a two-letter code in the *Reset Voltage Threshold Suffix Guide* (Table 1). Contact factory for availability of other voltage threshold combinations.

### Reset Outputs

The MAX6715A–MAX6729A/MAX6797A provide an active-low reset output ( $\overline{RST}$ ) and the MAX6725A/MAX6726A also provide an active-high ( $RST$ ) output.  $RST$ ,  $\overline{RST}$ ,  $\overline{RST1}$ , and  $\overline{RST2}$  are asserted when the voltage at either  $V_{CC1}$  or  $V_{CC2}$  falls below the voltage threshold level,  $RSTIN$  drops below threshold, or  $\overline{MR}$  is pulled low. Once reset is asserted, it stays low for the reset timeout period (see Table 2). If  $V_{CC1}$ ,  $V_{CC2}$ , or  $RSTIN$  goes below the reset threshold before the reset timeout period is completed, the internal timer restarts. The MAX6715A/MAX6717A/MAX6719A/MAX6721A/MAX6723A/MAX6725A/MAX6727A/MAX6728A contain open-drain reset outputs, while the MAX6716A/MAX6718A/MAX6720A/MAX6722A/MAX6724A/MAX6726A/MAX6729A/MAX6797A contain push-pull reset outputs. The MAX6727A provides two separate open-drain  $\overline{RST}$  outputs driven by the same internal logic.

### Manual-Reset Input

Many  $\mu$ P-based products require manual-reset capability, allowing the operator, a test technician, or external logic circuitry to initiate a reset. A logic-low on  $\overline{MR}$  asserts the reset output. Reset remains asserted while  $\overline{MR}$  is low for the reset timeout period ( $t_{RP}$ ) after  $\overline{MR}$  returns high. This input has an internal 50k $\Omega$  pullup resistor to  $V_{CC1}$  and can be left unconnected if not used.  $\overline{MR}$  can be driven with CMOS logic levels, or with open-drain/collector outputs. Connect a normally open momentary switch from  $\overline{MR}$  to GND to create a manual-reset function; external debounce circuitry is not required. If  $\overline{MR}$  is driven from long cables or if the device is used in a noisy environment, connect a 0.1 $\mu$ F capacitor from  $\overline{MR}$  to GND to provide additional noise immunity.

### Adjustable Input Voltage

The MAX6719A/MAX6720A and MAX6723A–MAX6727A provide an additional input to monitor a third system voltage. The threshold voltage at  $RSTIN$  is typically 626mV. Connect a resistor-divider network to the circuit as shown in Figure 1 to establish an externally controlled threshold voltage,  $V_{EXT\_TH}$ .

$$V_{EXT\_TH} = 626mV \cdot ((R1 + R2)/R2)$$

Low-leakage current at  $RSTIN$  allows the use of large-valued resistors resulting in reduced power consumption of the system.

### Watchdog Input

The watchdog monitors  $\mu$ P activity through the watchdog input (WDI). To use the watchdog function, connect WDI to a bus line or  $\mu$ P I/O line. When WDI remains high or low for longer than the watchdog timeout period, the reset output asserts.

The MAX6721A–MAX6729A/MAX6797A include a dual-mode watchdog timer to monitor  $\mu$ P activity. The flexible timeout architecture provides a long period initial watchdog mode, allowing complicated systems to complete lengthy boots, and a short period normal watchdog mode, allowing the supervisor to provide quick alerts when processor activity fails. After each reset event ( $V_{CC}$  power-up/brownout, manual reset, or watchdog reset), there is a long initial watchdog period of 35s minimum. The long watchdog period mode provides an extended time for the system to power-up and fully initialize all  $\mu$ P and system components before assuming responsibility for routine watchdog updates.

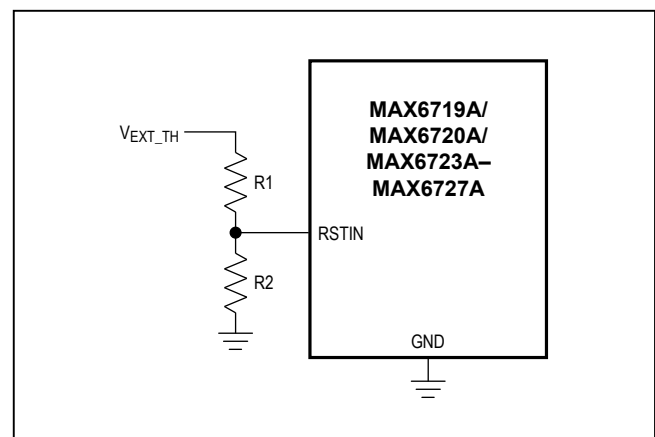

Figure 1. Monitoring a Third Voltage

The normal watchdog timeout period (1.12s min) begins after the first transition on WDI before the conclusion of the long initial watchdog period (Figure 2). During the normal operating mode, the supervisor will issue a reset pulse for the reset timeout period if the  $\mu$ P does not update the WDI with a valid transition (high-to-low or low-to-high) within the standard timeout period (1.12s min).

Leave WDI unconnected to disable the watchdog timer. The WDI unconnected-state detector uses a small (200nA typ) current source. Therefore, do not connect WDI to anything that will source more than 50nA.

### Power-Fail Comparator

PFI is the noninverting input to a comparator. If PFI is less than  $V_{PFI}$  (626.5mV),  $\overline{PFO}$  goes low. Common uses for the power-fail comparator include monitoring preregulated input of the power supply (such as a battery) or providing an early power-fail warning so software can conduct an orderly system shutdown. It can also be used to monitor supplies other than  $V_{CC1}$  or  $V_{CC2}$  by setting the power-fail threshold with a resistor-divider, as shown in Figure 3. PFI is the input to the power-fail comparator. The typical comparator delay is 2 $\mu$ s from PFI to  $\overline{PFO}$ . Connect PFI to ground of  $V_{CC1}$  if unused.

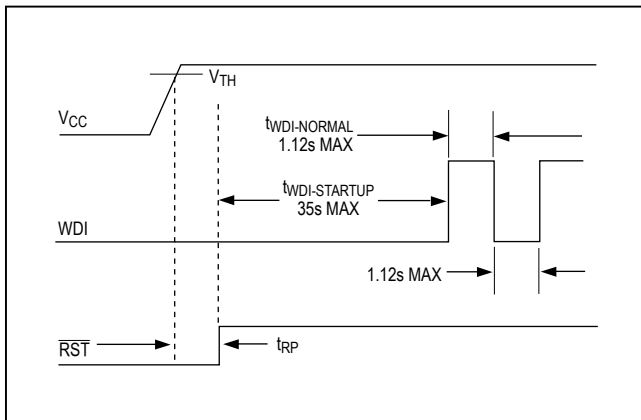

Figure 2. Normal Watchdog Startup Sequence

### Ensuring a Valid Reset Output Down to $V_{CC} = 0V$

The MAX6715A–MAX6729A/MAX6797A are guaranteed to operate properly down to  $V_{CC} = 0.8V$ . In applications that require valid reset levels down to  $V_{CC} = 0V$ , use a pulldown resistor at  $\overline{RST}$  to ground. The resistor value used is not critical, but it must be large enough not to load the reset output when  $V_{CC}$  is above the reset threshold. For most applications, 100k $\Omega$  is adequate. This configuration does not work for the open-drain outputs of the MAX6715A/MAX6717A/MAX6719A/MAX6721A/MAX6723A/MAX6725A/MAX6727A/MAX6728A. For push-pull, active-high RST output connect the external resistor as a pullup from RST to  $V_{CC1}$ .

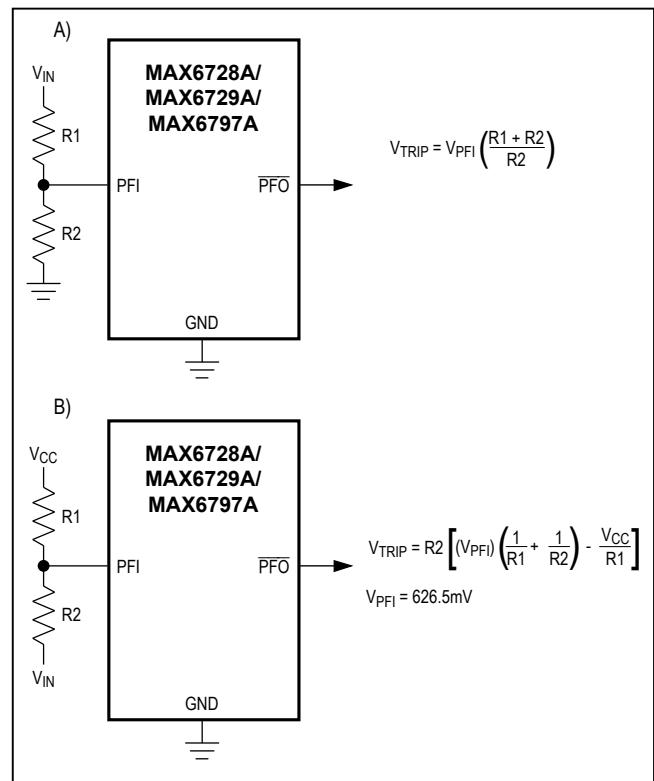

Figure 3. Using Power-Fail Input to Monitor an Additional Power-Supply a)  $V_{IN}$  is Positive b)  $V_{IN}$  is Negative

## Applications Information

### Interfacing to $\mu\text{P}$ s with Bidirectional Reset Pins

Most  $\mu\text{P}$ s with bidirectional reset pins can interface directly to open-drain  $\overline{\text{RST}}$  output options. Systems simultaneously requiring a push-pull  $\overline{\text{RST}}$  output and a bidirectional reset interface can be in logic contention. To prevent contention, connect a  $4.7\text{k}\Omega$  resistor between  $\overline{\text{RST}}$  and the  $\mu\text{P}$ 's reset I/O port, as shown in Figure 4.

### Adding Hysteresis to the Power-Fail Comparator

The power-fail comparator has a typical input hysteresis of  $3\text{mV}$ . This is sufficient for most applications where a power-supply line is being monitored through an external voltage-divider (see the *Power-Fail Comparator* section). If additional noise margin is desired, connect a resistor between  $\overline{\text{PFO}}$  and PFI as shown in Figure 5. Select the values of R1, R2, and R3 so PFI sees  $V_{\text{PFI}}$  ( $626\text{mV}$ ) when  $V_{\text{EXT}}$  falls to its power-fail trip point ( $V_{\text{FAIL}}$ ) and when  $V_{\text{IN}}$  rises to its power-good trip point ( $V_{\text{GOOD}}$ ). The hysteresis window extends between the specified  $V_{\text{FAIL}}$  and  $V_{\text{GOOD}}$  thresholds. R3 adds the additional hysteresis by sinking current from the R1/R2 divider network when  $\overline{\text{PFO}}$  is logic-low and sourcing current into the network when  $\overline{\text{PFO}}$  is logic-high. R3 is typically an order of magnitude greater than R1 or R2.

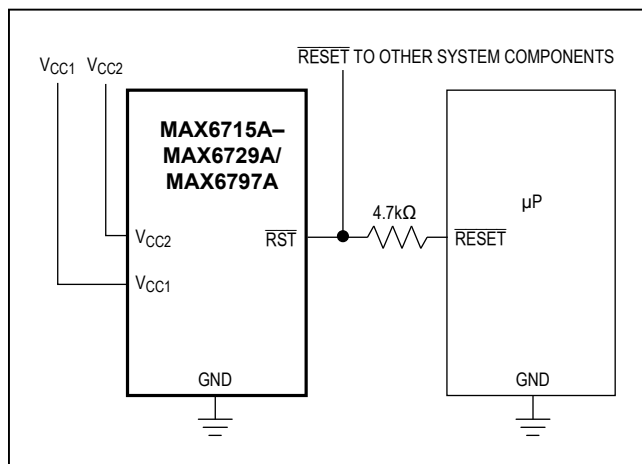

Figure 4. Interfacing to  $\mu\text{P}$ s with Bidirectional Reset I/O

The current through R2 should be at least  $2.5\mu\text{A}$  to ensure that the  $100\text{nA}$  (max) PFI input current does not significantly shift the trip points. Therefore,  $R2 < V_{\text{PFI}}/10\mu\text{A} < 62\text{k}\Omega$  for most applications. R3 will provide additional hysteresis for PFO push-pull ( $V_{\text{OH}} = V_{\text{CC1}}$ ) or open-drain ( $V_{\text{OH}} = V_{\text{PULLUP}}$ ) applications.

### Monitoring an Additional Power Supply

These  $\mu\text{P}$  supervisors can monitor either positive or negative supplies using a resistor voltage-divider to PFI.  $\overline{\text{PFO}}$  can be used to generate an interrupt to the  $\mu\text{P}$  or cause reset to assert (Figure 3).

### Monitoring a Negative Voltage

The power-fail comparator can be used to monitor a negative supply voltage using the circuit shown in Figure 3. When the negative supply is valid,  $\overline{\text{PFO}}$  is low. When the negative supply voltage drops,  $\overline{\text{PFO}}$  goes high. The circuit's accuracy is affected by the PFI threshold tolerance,  $V_{\text{CC}}$ , R1, and R2.

### Negative-Going $V_{\text{CC}}$ Transients

The MAX6715A–MAX6729A/MAX6797A supervisors are relatively immune to short-duration negative-going  $V_{\text{CC}}$  transients (glitches). It is usually undesirable to reset the  $\mu\text{P}$  when  $V_{\text{CC}}$  experiences only small glitches. The *Typical Operating Characteristics* show Maximum Transient Duration vs. Reset Threshold Overdrive, for which reset pulses are not generated. The graph was produced using negative-going  $V_{\text{CC}}$  pulses, starting above  $V_{\text{TH}}$  and ending below the reset threshold by the

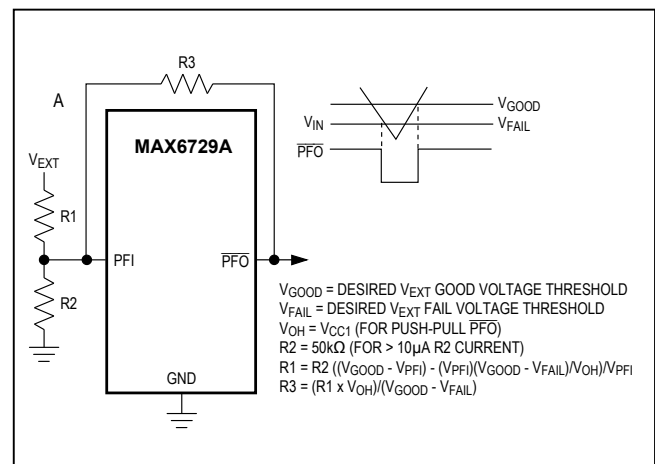

Figure 5. Adding Hysteresis to Power-Fail for Push-Pull PFO

magnitude indicated (reset threshold overdrive). The graph shows the maximum pulse width that a negative-going  $V_{CC}$  transient may typically have without causing a reset pulse to be issued. As the amplitude of the transient increases (i.e., goes farther below the reset threshold), the maximum allowable pulse width decreases. A  $0.1\mu\text{F}$  bypass capacitor mounted close to the  $V_{CC}$  pin provides additional transient immunity.

### Watchdog Software Considerations

Setting and resetting the watchdog input at different points in the program, rather than “pulsing” the watchdog input high-low-high or low-high-low, helps the watchdog timer to closely monitor software execution. This technique avoids a “stuck” loop where the watchdog timer continues to be reset within the loop, keeping the watchdog from timing out. Figure 6 shows an example flow diagram where the I/O driving the watchdog input is set high at the beginning of the program, set low at the beginning of every subroutine or loop, then set high again when the program returns to the beginning. If the program should “hang” in any subroutine, the I/O is continually set low and the watchdog timer is allowed to time out, causing a reset or interrupt to be issued.

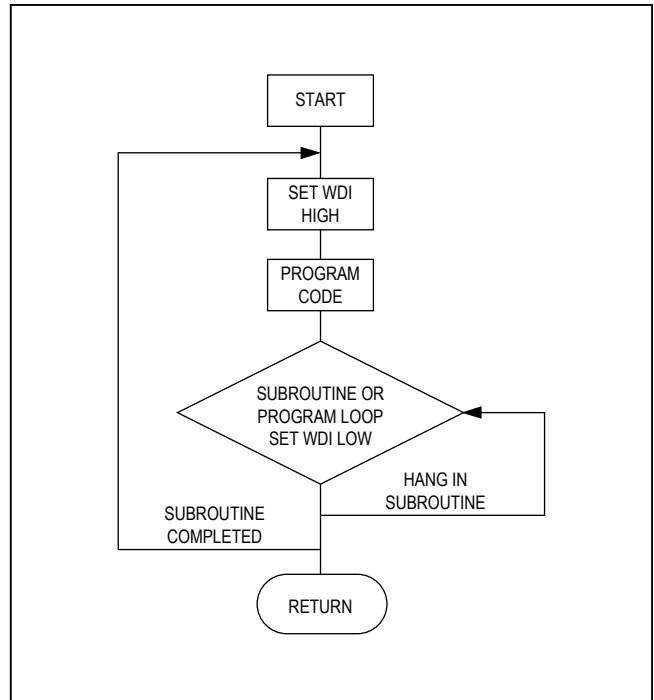
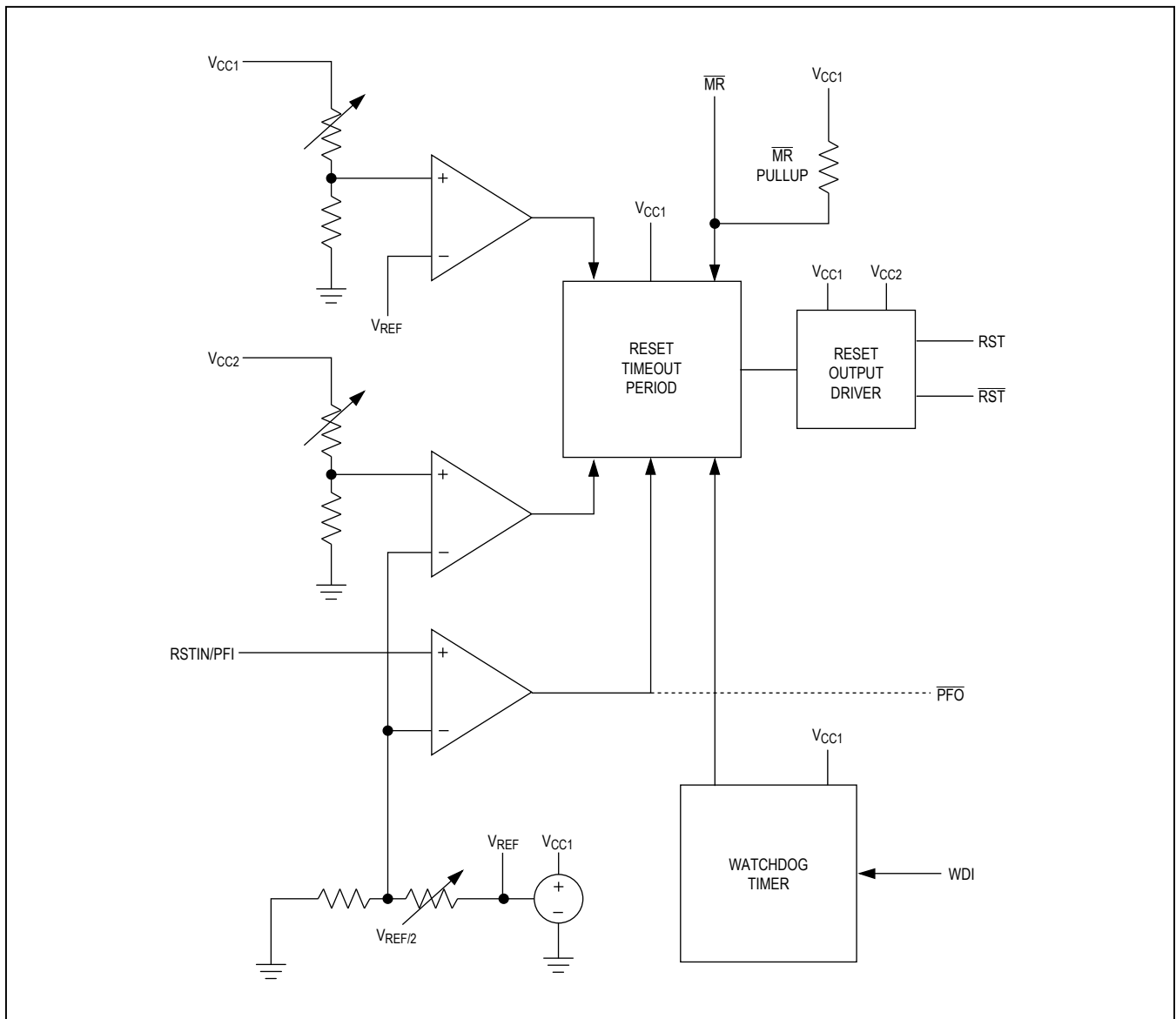

Figure 6. Watchdog Flow Diagram

### Functional Diagram



## Selector Guide

PART NUMBER	NUMBER OF VOLTAGE MONITORS	OPEN-DRAIN RESET	OPEN-DRAIN RESET	PUSH-PULL RESET	PUSH-PULL RESET	MANUAL RESET	WATCH-DOG INPUT	POWER-FAIL INPUT/ OUTPUT
MAX6715A	2	2	—	—	—	√	—	—
MAX6716A	2	—	—	2	—	√	—	—
MAX6717A	2	1	—	—	—	√	—	—
MAX6718A	2	—	—	1	—	√	—	—
MAX6719A	3	1	—	—	—	√	—	—
MAX6720A	3	—	—	1	—	√	—	—
MAX6721A	2	1	—	—	—	√	√	—
MAX6722A	2	—	—	1	—	√	√	—
MAX6723A	3	1	—	—	—	—	√	—
MAX6724A	3	—	—	1	—	—	√	—
MAX6725A	3	1	1	—	—	√	√	—
MAX6726A	3	—	—	1	1	√	√	—
MAX6727A	3	2	—	—	—	√	√	—
MAX6728A	2	1	—	—	—	√	√	√ (open drain)
MAX6729A	2	—	—	1	—	√	√	√ (push-pull)
MAX6797A	2	—	—	1	—	√	√	√ (open drain)

## Ordering Information

PART	TEMP RANGE	PIN-PACKAGE
MAX6715AUT__D_+T	-40°C to +125°C	6 SOT23
MAX6716AUT__D_+T	-40°C to +125°C	6 SOT23
MAX6717AUK__D_+T	-40°C to +125°C	5 SOT23
MAX6718AUK__D_+T	-40°C to +125°C	5 SOT23
MAX6719AUT__D_+T	-40°C to +125°C	6 SOT23
MAX6719AUT__D_/V+T*	-40°C to +125°C	6 SOT23
MAX6719AUTTWD1/V+T	-40°C to +125°C	6 SOT23
MAX6720AUT__D_+T	-40°C to +125°C	6 SOT23
MAX6721AUT__D_+T	-40°C to +125°C	6 SOT23

PART	TEMP RANGE	PIN-PACKAGE
MAX6722AUT__D_+T	-40°C to +125°C	6 SOT23
MAX6723AUT__D_+T	-40°C to +125°C	6 SOT23
MAX6724AUT__D_+T	-40°C to +125°C	6 SOT23
MAX6725AKA__D_+T	-40°C to +125°C	8 SOT23
MAX6726AKA__D_+T	-40°C to +125°C	8 SOT23
MAX6727AKA__D_+T	-40°C to +125°C	8 SOT23
MAX6728AKA__D_+T	-40°C to +125°C	8 SOT23
MAX6729AKA__D_+T	-40°C to +125°C	8 SOT23
MAX6797AKA__D_+T	-40°C to +125°C	8 SOT23

+Denotes a lead(Pb)-free/RoHS-compliant package.

T = Tape and reel.

**Note:** The first “\_\_” are placeholders for the threshold voltage levels of the devices. Desired threshold levels are set by the part number suffix found in the Reset Voltage Threshold Suffix Guide. The “\_” after the D is a placeholder for the reset timeout delay time. Desired delay time is set using the timeout period suffix found in the Reset Timeout Period Suffix Guide. For example, the MAX6716AULTLD3-T is a dual-voltage supervisor  $V_{TH1} = 4.625V$ ,  $V_{TH2} = 3.075V$ , and 210ms (typ) timeout period.

**Table 1. Reset Voltage Threshold Suffix Guide\*\***

PART NUMBER SUFFIX ( _ )	V <sub>CC1</sub> NOMINAL VOLTAGE THRESHOLD (V)	V <sub>CC2</sub> NOMINAL VOLTAGE THRESHOLD (V)
LT	<b>4.625</b>	<b>3.075</b>
MS	4.375	2.925
MR	4.375	2.625
TZ	3.075	2.313
<b>SY</b>	<b>2.925</b>	<b>2.188</b>
RY	2.625	2.188
TW	3.075	1.665
<b>SV</b>	<b>2.925</b>	<b>1.575</b>
<b>RV</b>	<b>2.625</b>	<b>1.575</b>
TI	3.075	1.388
<b>SH</b>	<b>2.925</b>	<b>1.313</b>
RH	2.625	1.313
<b>TG</b>	<b>3.075</b>	<b>1.110</b>
SF	2.925	1.050
RF	2.625	1.050
TE	3.075	0.833
<b>SD</b>	<b>2.925</b>	<b>0.788</b>
RD	2.625	0.788
<b>ZW</b>	<b>2.313</b>	<b>1.665</b>
YV	2.188	1.575
ZI	2.313	1.388
<b>YH</b>	<b>2.188</b>	<b>1.313</b>
<b>ZG</b>	<b>2.313</b>	<b>1.110</b>
YF	2.188	1.050
ZE	2.313	0.833
<b>YD</b>	<b>2.188</b>	<b>0.788</b>
WI	1.665	1.388
<b>VH</b>	<b>1.575</b>	<b>1.313</b>
<b>WG</b>	<b>1.665</b>	<b>1.110</b>
VF	1.575	1.050
WE	1.665	0.833
<b>VD</b>	<b>1.575</b>	<b>0.788</b>

**Note:** Standard versions are shown in bold and are available in a D3 timeout option only. Standard versions require 2500-piece-order increments and are typically held in sample stock. There is a 10,000 order increment on nonstandard versions. **Other threshold voltages may be available; contact factory for availability.**

**Table 2. Reset Timeout Period Suffix Guide**

TIMEOUT PERIOD SUFFIX	ACTIVE TIMEOUT PERIOD	
	MIN (ms)	MAX (ms)
D1	1.1	2.2
D2	8.8	17.6
D7†	17.5	35.0
D8†	35.0	70.0
D3	140	280
D5	280	560
D6	560	1120
D4	1120	2240

†D7 and D8 timeout periods are only available for the MAX6797A.

## Pin Configurations

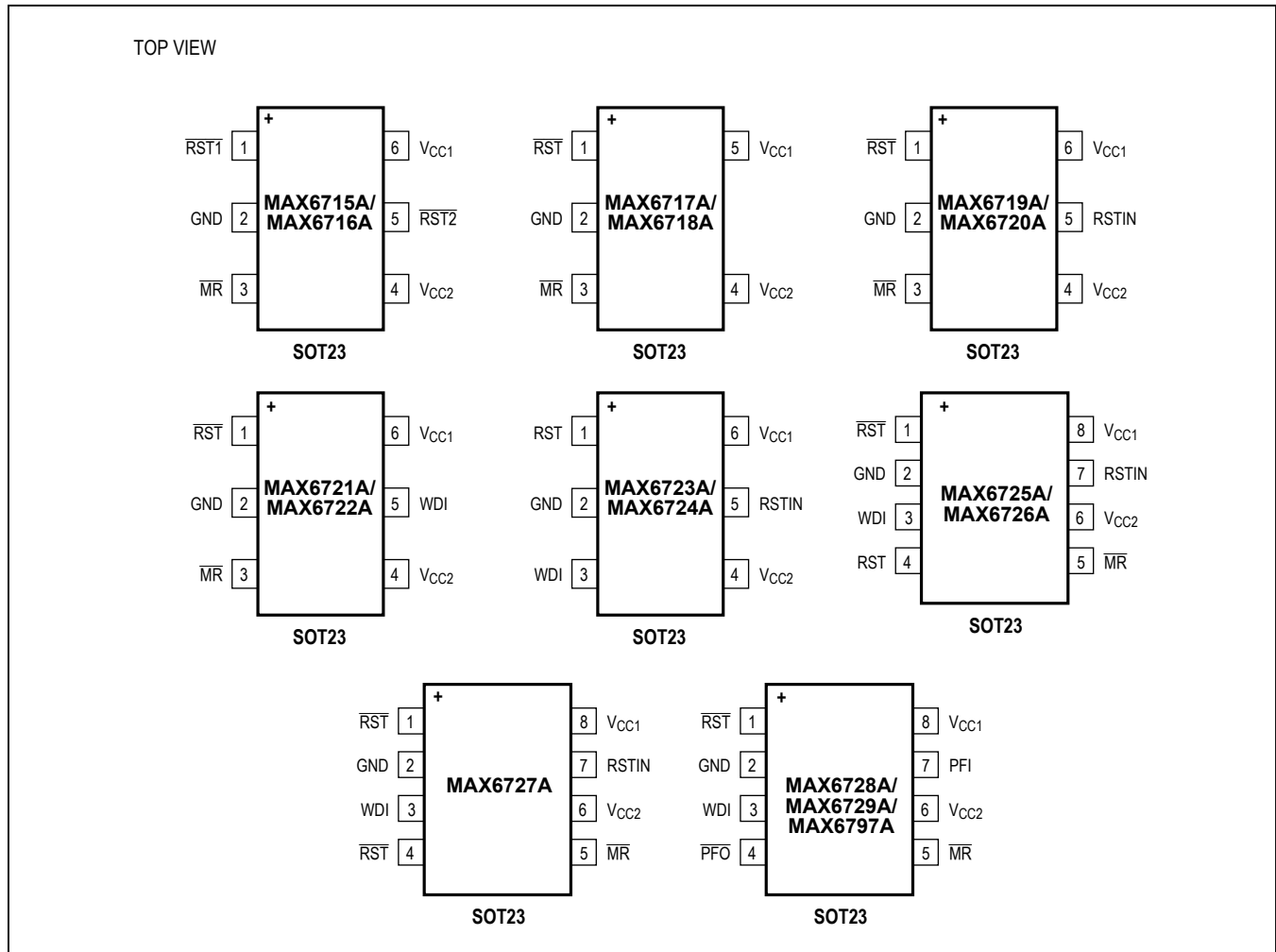

## Chip Information

PROCESS: BiCMOS

## Package Information

For the latest package outline information and land patterns (footprints), go to [www.maximintegrated.com/packages](http://www.maximintegrated.com/packages). Note that a "+", "#", or "-" in the package code indicates RoHS status only. Package drawings may show a different suffix character, but the drawing pertains to the package regardless of RoHS status.

PACKAGE TYPE	PACKAGE CODE	OUTLINE NO.	LAND PATTERN NO.
5 SOT23	U5+1	<a href="#">21-0057</a>	<a href="#">90-0174</a>
6 SOT23	U6+1	<a href="#">21-0058</a>	<a href="#">90-0175</a>
8 SOT23	K8SN+1	<a href="#">21-0078</a>	<a href="#">90-0176</a>

## Revision History

REVISION NUMBER	REVISION DATE	DESCRIPTION	PAGES CHANGED
0	4/06	Initial release	—
1	7/06	Updated <i>Ordering Information</i>	1, 15
2	6/08	Added the MAX6797A to <i>Ordering Information, Electrical Characteristics, Pin Description, Detailed Description, Figures 4 and 5, Selector Guide, Table 2, Pin Configurations</i>	1, 2, 6–11, 12, 15–17
3	9/08	Updated <i>Selector Guide</i>	15
4	3/14	Added automotive part to the <i>Ordering Information</i> table	1
5	10/17	Added AEC qualification statement to <i>Benefits and Features</i> section and updated <i>Ordering Information</i> table	1, 17

For pricing, delivery, and ordering information, please contact Maxim Direct at 1-888-629-4642, or visit Maxim Integrated's website at [www.maximintegrated.com](http://www.maximintegrated.com).

Maxim Integrated cannot assume responsibility for use of any circuitry other than circuitry entirely embodied in a Maxim Integrated product. No circuit patent licenses are implied. Maxim Integrated reserves the right to change the circuitry and specifications without notice at any time. The parametric values (min and max limits) shown in the *Electrical Characteristics* table are guaranteed. Other parametric values quoted in this data sheet are provided for guidance.

## Looking for pricing, stock, or lifecycle information?

Click below to explore more details on WIN SOURCE:

 [View MAX6719AUTTGD3+T on WIN SOURCE](#)

 [Maxim Integrated](#) Information

## Optimize Your Supply Chain with WIN SOURCE Solutions

-  Global Sourcing Solution
-  Obsolete Management
-  Cost Control Management
-  Shortage Management
-  Alternative Solution
-  Excess Inventory Management