



**THE DATASHEET OF  
MAX8607ETD+T**



EVALUATION KIT  
AVAILABLE

MAXIM

# 1MHz PWM Boost Converter for 1.5A White LED Camera Flash

MAX8607

## General Description

The MAX8607 white LED boost converter is optimized for camera flash/strobe applications using high-current white LEDs. The MAX8607 integrates a 1MHz PWM boost converter, 1.5A low-dropout (LDO) current regulator, and logic control circuitry for a space-saving LED flash design. Two logic inputs control four modes of operation: shutdown mode reduces the quiescent current to 0.1 $\mu$ A (typ), movie mode supplies up to 360mA of LED current for continuous lighting, flash mode supplies up to 1.5A of LED current for short-duration lighting during an exposure, and disco mode supplies +5V (at up to 1A) to external circuits while driving the LED with a fixed 80mA current.

The internal 1MHz boost converter features an adaptive control scheme with an internal switching MOSFET and synchronous rectifier to improve efficiency and minimize external component count. The MAX8607 is available in a 14-pin, 3mm x 3mm TDFN package (0.8mm max height).

## Applications

Camera Flashes/Strobes  
Cell Phones/Smartphones  
PDAs and Digital Cameras

## Pin Configuration

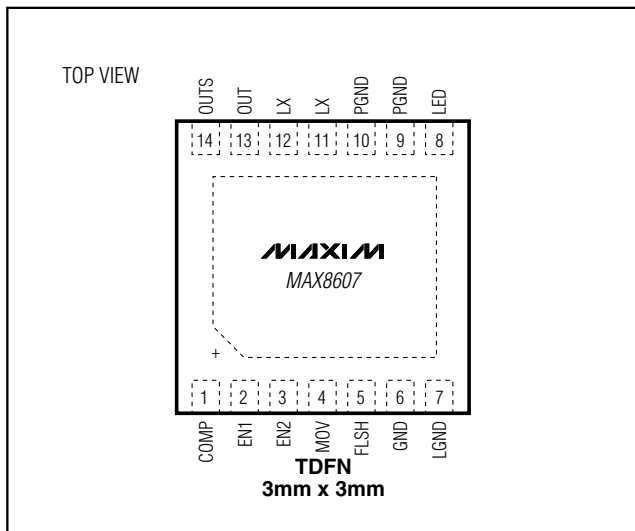

## Features

- ◆ Supports Lumileds and Other High-Power White LEDs
- ◆ Independently Set Flash/Movie Currents  
Flash-Mode Current Up to 1.5A  
Movie-Mode Current Up to 360mA
- ◆ Disco Mode with Fixed 5V (Up to 1A) and 80mA LED Current
- ◆ 84% Efficiency (PLED / PBATT) at 1.1A
- ◆  $T_A$  Derating Function for LED Thermal Protection
- ◆ Output Overvoltage Protection (OVP)
- ◆ Soft-Start Eliminates Inrush Current
- ◆ 1MHz PWM Operation at All Loads
- ◆ Small External Components
- ◆ 2.7V to 5.5V Input Voltage Range
- ◆ 0.1 $\mu$ A Shutdown Mode
- ◆ 14-Pin, 3mm x 3mm TDFN Package

## Ordering Information

PART*	PIN-PACKAGE	TOP MARK
MAX8607ETD+	14 TDFN 3mm x 3mm (T1433-1)	ABA

+Indicates lead-free package.

\*The MAX8607ETD is characterized over the -40°C to +85°C temperature range.

## Typical Operating Circuit

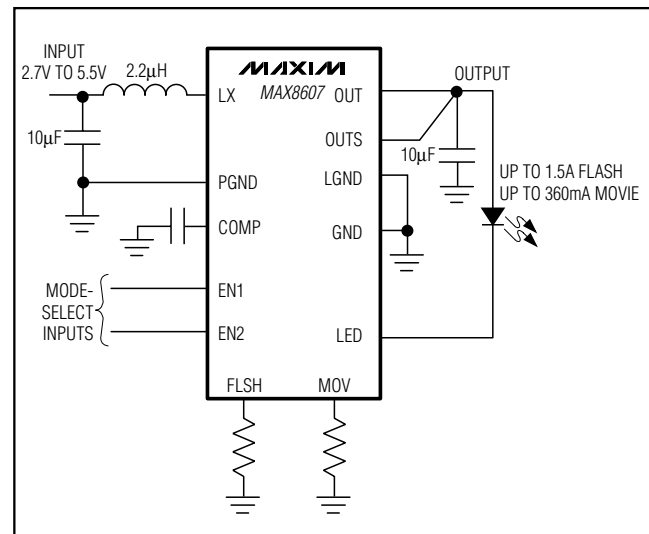

MAXIM

Maxim Integrated Products 1

For pricing, delivery, and ordering information, please contact Maxim/Dallas Direct! at 1-888-629-4642, or visit Maxim's website at [www.maxim-ic.com](http://www.maxim-ic.com).

# 1MHz PWM Boost Converter for 1.5A White LED Camera Flash

## ABSOLUTE MAXIMUM RATINGS

OUT, OUTS, EN1, EN2 to GND .....-0.3V to +6V  
 FLSH, MOV, LED, COMP, LX to GND ....-0.3V to (V<sub>OUTS</sub> + 0.3V)  
 LGND, PGND to GND. ....-0.3V to +0.3V  
 LX Current. ....2A<sub>RMS</sub>  
 Continuous Power Dissipation (T<sub>A</sub> = +70°C)  
 14-Pin TDFN 3mm x 3mm (derate 18.2mW/°C  
 above +70°C).....1455mW

Operating Temperature Range .....-40°C to +85°C  
 Storage Temperature Range .....-65°C to +150°C  
 Lead Temperature (soldering, 10s) .....+300°C

Stresses beyond those listed under "Absolute Maximum Ratings" may cause permanent damage to the device. These are stress ratings only, and functional operation of the device at these or any other conditions beyond those indicated in the operational sections of the specifications is not implied. Exposure to absolute maximum rating conditions for extended periods may affect device reliability.

## ELECTRICAL CHARACTERISTICS

(V<sub>EN1</sub> = V<sub>EN2</sub> = 5V, V<sub>OUT</sub> = V<sub>OUTS</sub> = 4V, C<sub>OUT</sub> = 10μF, T<sub>A</sub> = -40°C to +85°C. Typical values are at T<sub>A</sub> = +25°C, unless otherwise noted.) (Note 1)

PARAMETER	CONDITIONS	MIN	TYP	MAX	UNITS	
Supply Voltage	IC supplied from OUTS	2.7		5.5	V	
Undervoltage-Lockout Threshold	V <sub>OUTS</sub> rising, 100mV (typ) hysteresis	2.25	2.38	2.65	V	
OUT Quiescent Current, Flash or Movie Mode	LX switching, I <sub>LED</sub> = 0mA		4		mA	
OUT Quiescent Current, Shutdown Mode	EN1 = EN2 = GND	T <sub>A</sub> = +25°C	0.1	1	μA	
		T <sub>A</sub> = +85°C	1			
OUT Regulation Voltage	Overvoltage limit, I <sub>LED</sub> = 0mA, V <sub>LED</sub> = 0V	5.3	5.5	5.7	V	
	V <sub>LED</sub> = 0.5V	3.65	3.85	3.95		
	Disco mode, I <sub>LED</sub> = 80mA	4.8	5.0	5.2		
LED Current, Shutdown Mode	EN1 = EN2 = GND	T <sub>A</sub> = +25°C	0.01	1	μA	
		T <sub>A</sub> = +85°C	0.5			
Current-Source Guaranteed Sink Current	R <sub>MOV</sub> = 2kΩ, R <sub>FLSH</sub> = 2kΩ, V <sub>LED</sub> = 0.5V	Flash mode	1200	1500	mA	
		Movie mode	338	360		
		Disco mode		80		
Current-Source Multiplier in MOV Mode (I <sub>LED</sub> / I <sub>MOV</sub> )	I <sub>MOV</sub> up to 300μA		1200		A/A	
Current-Source Accuracy in MOV Mode	R <sub>MOV</sub> = 2kΩ, V <sub>LED</sub> = 0.5V	T <sub>A</sub> ≥ 0°C (Note 2)	-3	±0.5	+3	%
		T <sub>A</sub> = -40°C	-6	±0.5	+6	
MOV Current-Source Dropout Voltage	R <sub>MOV</sub> = 2kΩ		48	100	mV	
Disco Current-Source Current Setting	V <sub>EN1</sub> = 0V, V <sub>EN2</sub> = 5V	62	80	108	mA	
Current-Source Multiplier in FLSH Mode (I <sub>LED</sub> / I <sub>FLSH</sub> )	I <sub>FLSH</sub> up to 300μA		5000		A/A	
Current-Source Accuracy in FLSH Mode	R <sub>FLSH</sub> = 2kΩ, V <sub>LED</sub> = 0.5V, T <sub>A</sub> ≥ -40°C (Note 2)		±3		%	
FLSH Current-Source Dropout Voltage	R <sub>FLSH</sub> = 2kΩ		200	420	mV	
LX n-Channel Current Limit			4.4		A	
MOV Regulation Voltage			600		mV	
FLSH Regulation Voltage			600		mV	
LED to COMP Transconductance	V <sub>COMP</sub> = 1.5V		60		μS	

# 1MHz PWM Boost Converter for 1.5A White LED Camera Flash

MAX8607

## ELECTRICAL CHARACTERISTICS (continued)

( $V_{EN1} = V_{EN2} = 5V$ ,  $V_{OUT} = V_{OUTS} = 4V$ ,  $C_{OUT} = 10\mu F$ ,  $T_A = -40^\circ C$  to  $+85^\circ C$ . Typical values are at  $T_A = +25^\circ C$ , unless otherwise noted.) (Note 1)

PARAMETER	CONDITIONS	MIN	TYP	MAX	UNITS
COMP Input Resistance to GND	During shutdown or UVLO		140	250	$\Omega$
LED $T_A$ Derating Function Threshold	Temperature when the LED current derating function begins		+40		$^\circ C$
LED $T_A$ Derating Function Slope	$T_A = +40^\circ C$ to $+85^\circ C$		-1.67		$\%/^\circ C$
EN1 and EN2 Logic-High Input Voltage	$V_{OUTS} = 2.7V$ to $5.5V$	1.4			V
EN1 and EN2 Logic-Low Input Voltage	$V_{OUTS} = 2.7V$ to $5.5V$			0.4	V
EN1 and EN2 Logic Input Bias Current	$V_{EN\_} = 5.5V$	$T_A = +25^\circ C$	0.01	1	$\mu A$
		$T_A = +85^\circ C$	0.03		
LX n-Channel On-Resistance	$I_{LX} = 200mA$		50	100	$m\Omega$
LX p-Channel On-Resistance	$I_{LX} = 200mA$		100	200	$m\Omega$
LX Leakage	$V_{LX} = 5.5V$	$T_A = +25^\circ C$	0.01	1	$\mu A$
		$T_A = +85^\circ C$	0.03		
Operating Frequency		0.8	1.0	1.2	MHz
Maximum Duty Cycle		65	75		%
Minimum Duty Cycle			4	8	%

**Note 1:** All devices are production tested at  $T_A = +25^\circ C$ . Specifications over temperature are guaranteed by design and characterization and not production tested.

**Note 2:** For temperatures below the thermal derating start point.

## Typical Operating Characteristics

(Circuit of Figure 2,  $V_{IN} = V_{EN1} = 3.6V$ ,  $V_{EN2} = 0V$ ,  $T_A = +25^\circ C$ , unless otherwise noted.)

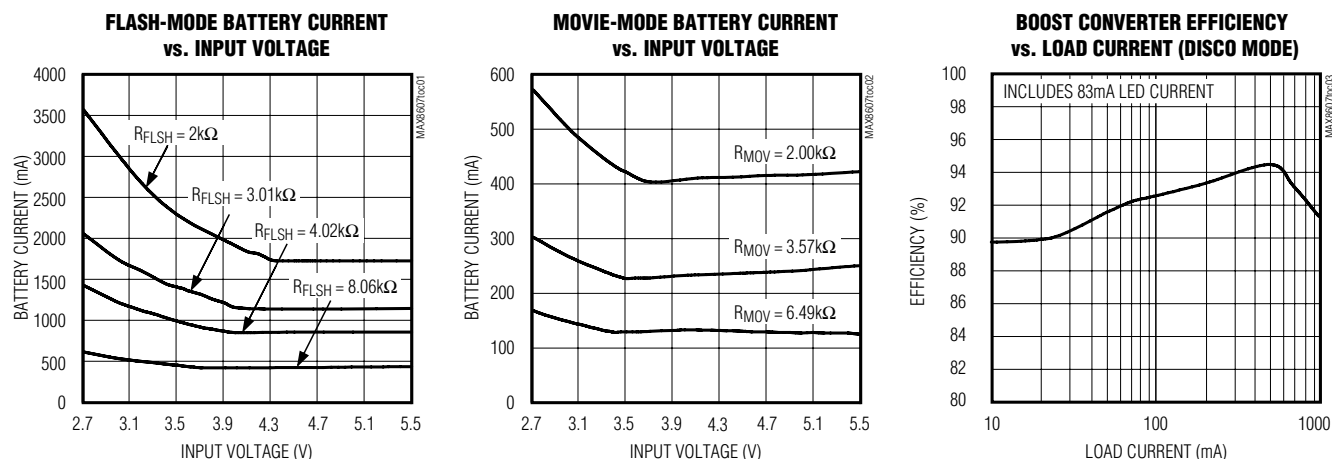

# 1MHz PWM Boost Converter for 1.5A White LED Camera Flash

## Typical Operating Characteristics (continued)

(Circuit of Figure 2,  $V_{IN} = V_{EN1} = 3.6V$ ,  $V_{EN2} = 0V$ ,  $T_A = +25^\circ C$ , unless otherwise noted.)

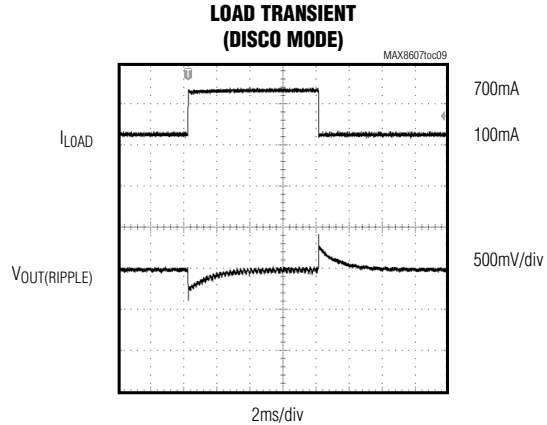
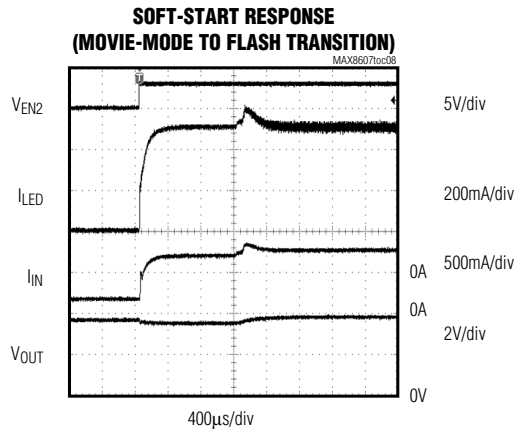
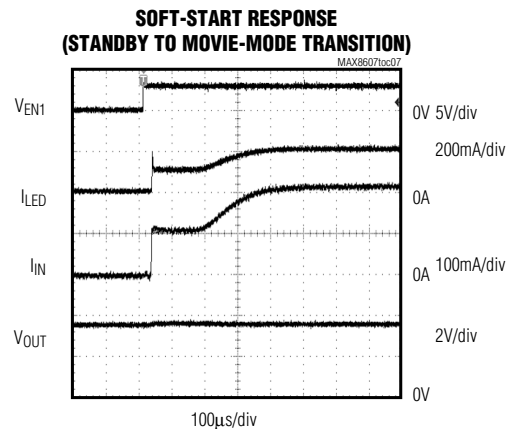
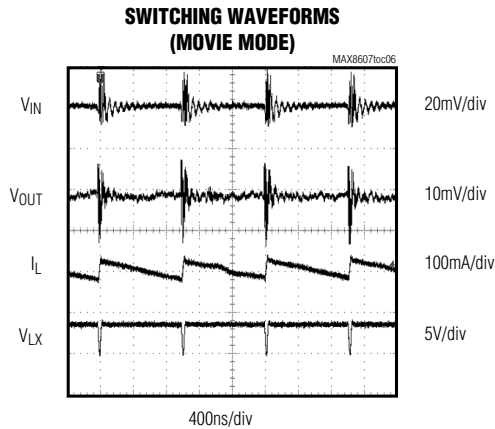
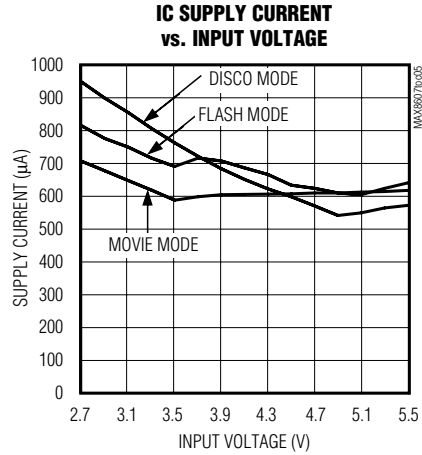
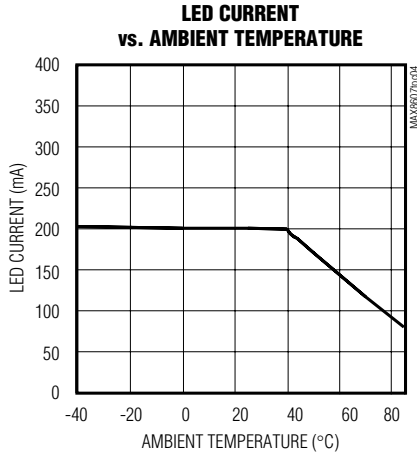

# 1MHz PWM Boost Converter for 1.5A White LED Camera Flash

MAX8607

## Typical Operating Characteristics (continued)

(Circuit of Figure 2,  $V_{IN} = V_{EN1} = 3.6V$ ,  $V_{EN2} = 0V$ ,  $T_A = +25^\circ C$ , unless otherwise noted.)

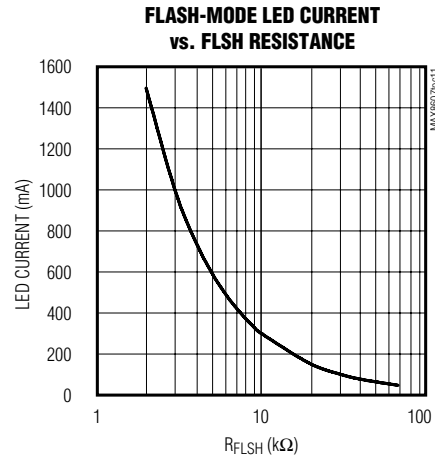
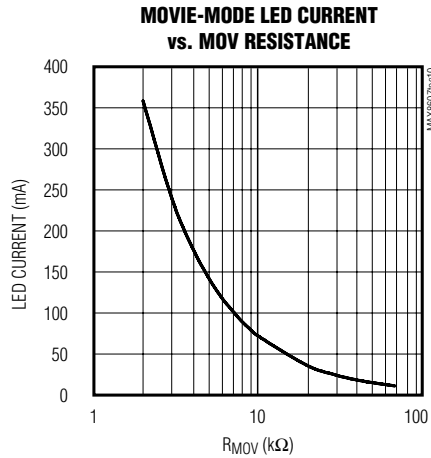

## Pin Description

PIN	NAME	FUNCTION
1	COMP	Compensation Input. Connect a 0.1 $\mu$ F ceramic capacitor from COMP to GND for regulator stability.
2	EN1	Enable Input 1. EN1 and EN2 set the operating mode (see Table 1).
3	EN2	Enable Input 2. EN1 and EN2 set the operating mode (see Table 1).
4	MOV	Movie Current Program Input. Connect a resistor from MOV to GND to set the LED current in movie mode. $R_{MOV}$ must be greater than 2k $\Omega$ .
5	FLSH	Flash Current Program Input. Connect a resistor from FLSH to GND to set the LED current in flash mode. $R_{FLSH}$ must be greater than 2k $\Omega$ .
6	GND	Analog Ground. Connect GND to the exposed paddle directly under the IC.
7	LGND	LED Current Regulator Ground. Connect LGND to the ground plane on the PC board.
8	LED	LED Current Regulator. Connect LED to the cathode of the external LED. LED is high impedance during shutdown.
9, 10	PGND	Power Ground. Connect PGND to the input capacitor ground. Also, connect PGND to the PC board ground plane.
11, 12	LX	Inductor Connection. Connect LX to the switched side of the inductor. LX is internally connected to the drains of the internal MOSFETs. Both MOSFETs are off during shutdown.
13	OUT	Regulator Output. Connect OUT to the anode of the external LED. Bypass OUT to PGND with a 10 $\mu$ F or larger ceramic capacitor. During shutdown, OUT is one body-diode drop below the input voltage.
14	OUTS	Output Sense and IC Supply Input. Connect OUTS to OUT at the output bypass capacitor. The IC's operating power is supplied from OUTS.
—	EP	Exposed Paddle. Connect the exposed paddle to GND directly under the IC and to a large PC board ground plane for increased thermal performance.

# 1MHz PWM Boost Converter for 1.5A White LED Camera Flash

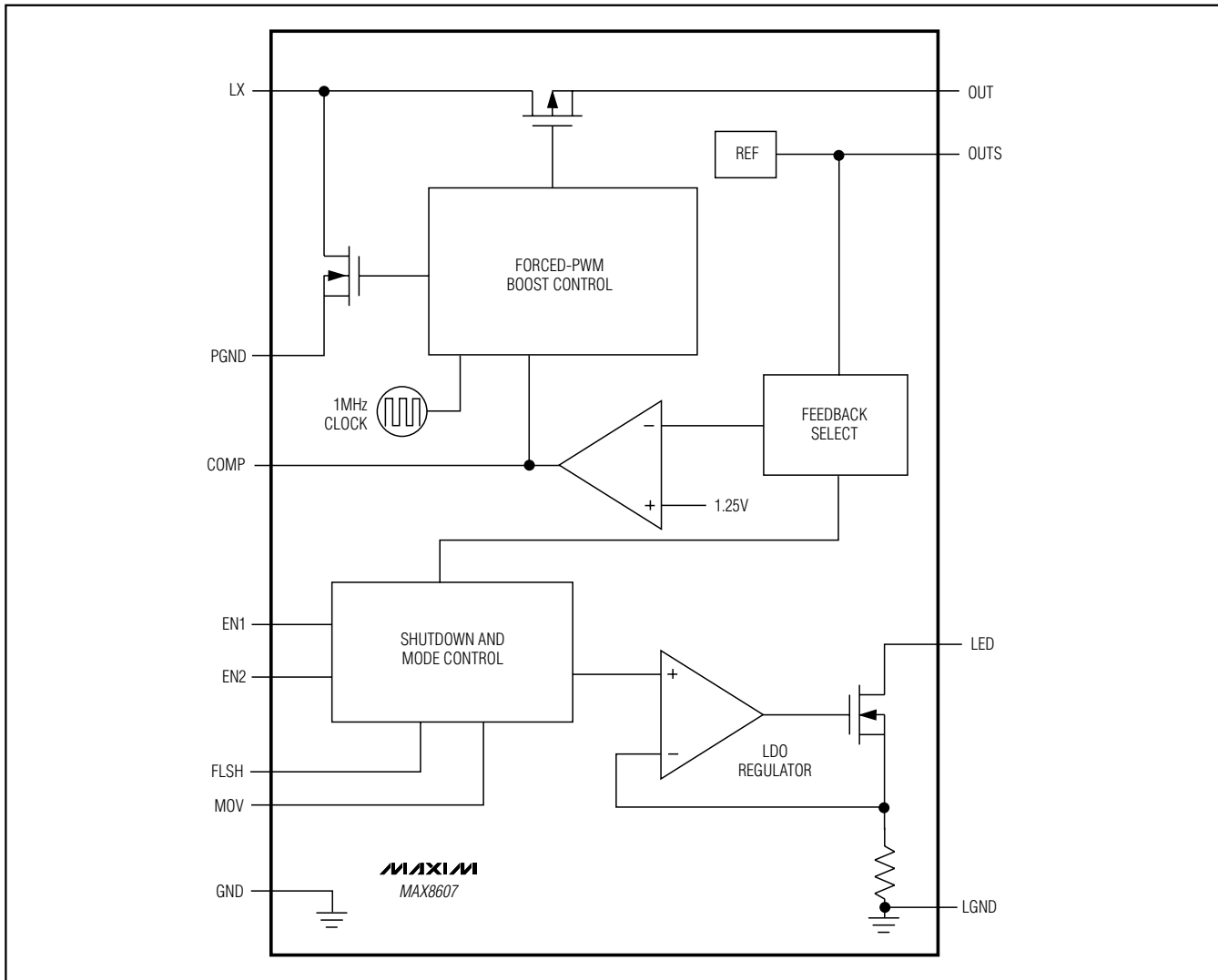

Figure 1. Functional Diagram

## Detailed Description

### Boost Converter

The MAX8607 includes a fixed-frequency, PWM boost converter that supplies the LED current. The output voltage is adaptively controlled to provide adequate headroom with varying LED forward voltage. The boost converter switches an internal power MOSFET and synchronous rectifier at a constant 1MHz frequency with varying duty cycle up to 75% to maintain constant LED current over the 2.7V to 5.5V input range. Internal special circuits prevent any unwanted subharmonic switching in the critical buck/boost region.

### LDO Current Regulator (LED)

A low-dropout (LDO) linear current regulator from LED to LGND sinks current from the external LED's cathode terminal. The LED current is regulated to a user-programmable level. In movie mode, the current into LED is regulated to 1200 times the current set by the MOV resistor ( $R_{MOV}$ ). In flash mode, the current into LED is regulated to 5000 times the current set by the FLSH resistor ( $R_{FLSH}$ ). In disco mode, the current into LED is regulated to 80mA.

# 1MHz PWM Boost Converter for 1.5A White LED Camera Flash

MAX8607

## Mode-Select Inputs (EN1, EN2)

Drive EN1 high and EN2 low to enable movie mode. In this mode, the current regulator regulates the current through the LED to 1200 times the current set by the MOV resistor. See the *Setting the Movie-Mode Current* section for details on setting the movie-mode current.

Drive EN1 and EN2 high to enable flash mode. In this mode, the current through the LED is regulated to 5000 times the current set by the FLSH resistor. See the *Setting the Flash-Mode Current* section for details on setting the flash-mode current. The time duration of the flash mode must be set using external circuitry or software.

Drive EN1 low and EN2 high to enable disco mode. In this mode, the output of the boost converter provides a regulated +5V at up to 1A for external circuitry, while the LED current is regulated to 80mA. The LED current is not adjustable in this mode.

Drive EN1 and EN2 low to place the IC into a low-power shutdown mode. See the *Shutdown* section for more details.

## Overvoltage Protection

The output voltage of the MAX8607 is limited by internal overvoltage-protection (OVP) circuitry, which prevents the output from exceeding 5.7V under any conditions. In flash and movie modes, if the output voltage nears 5.5V, the LED current is smoothly reduced through proprietary means to prevent overvoltage without sudden termination of the output current. In case of an LED with very high forward voltage (VF), this circuit provides more reliable and repeatable flash than would a simple on/off comparator. In disco mode, the output is limited by the internal 5.0V regulation.

## Undervoltage Lockout

The MAX8607 contains undervoltage-lockout (UVLO) circuitry that disables the IC until V<sub>OUTS</sub> is greater than 2.38V. Prior to startup, V<sub>OUTS</sub> is one diode drop below the input voltage. This ensures a great enough input voltage for startup.

## Soft-Start

The MAX8607 attains soft-start by charging C<sub>COMP</sub> with a 100µA current source. During this time, the internal MOSFET is switching at the minimum duty cycle. Once V<sub>COMP</sub> rises above 1V, the duty cycle increases until output reaches the desired regulation level. COMP is pulled to GND with a 140Ω internal resistor during UVLO, OVP, or shutdown. See the *Typical Operating Characteristics* for an example of soft-start operation.

Table 1. EN1 and EN2 Mode Selection

EN1	EN2	MODE
0	0	Shutdown
0	1	Disco Mode
1	0	Movie Mode
1	1	Flash Mode

## Shutdown

Drive EN1 and EN2 low to place the MAX8607 into a low-power shutdown mode. In shutdown, supply current is reduced to 0.1µA (typ). C<sub>COMP</sub> is discharged during shutdown, allowing the device to reinitiate soft-start when it is enabled. The internal MOSFET and synchronous rectifier are turned off during shutdown; however, OUT is one body-diode drop below the input. LED is high impedance so the external LED is off, but any external circuitry on OUT is not disconnected and, therefore, should include its own shutdown capability. Typical shutdown timing characteristics are shown in the *Typical Operating Characteristics*.

## Ambient Temperature Derating Function

The MAX8607 limits the maximum LED current depending on its die temperature. Once the die temperature reaches +40°C, the LED current decreases by 1.67% per °C. This corresponds to approximately 0mA of LED current at +100°C. Due to the package's exposed paddle, the die temperature is very close to the PC board temperature. The temperature derating function allows the LED current to be safely set higher at normal operating temperatures, thereby allowing either a brighter flash or movie light to be used for normal ambient temperatures. See the *Typical Operating Characteristics* for a graph of LED Current vs. Ambient Temperature.

## Applications Information

### Setting the Movie-Mode Current

To set the LED current during movie mode, connect a resistor from MOV to GND (R<sub>MOV</sub>). V<sub>MOV</sub> is regulated to 0.6V and the current through R<sub>MOV</sub> is mirrored to LED with a gain of 1200. R<sub>MOV</sub> is calculated as:

$$R_{MOV} = (0.6V \times 1200) / I_{LED(MOV)}$$

### Setting the Flash-Mode Current

To set the LED current during flash mode, connect a resistor from FLSH to GND (R<sub>FLSH</sub>). V<sub>FLSH</sub> is regulated to 0.6V and the current through R<sub>FLSH</sub> is mirrored to LED with a gain of 5000. R<sub>FLSH</sub> is calculated as:

$$R_{FLSH} = (0.6V \times 5000) / I_{LED(FLSH)}$$

# 1MHz PWM Boost Converter for 1.5A White LED Camera Flash

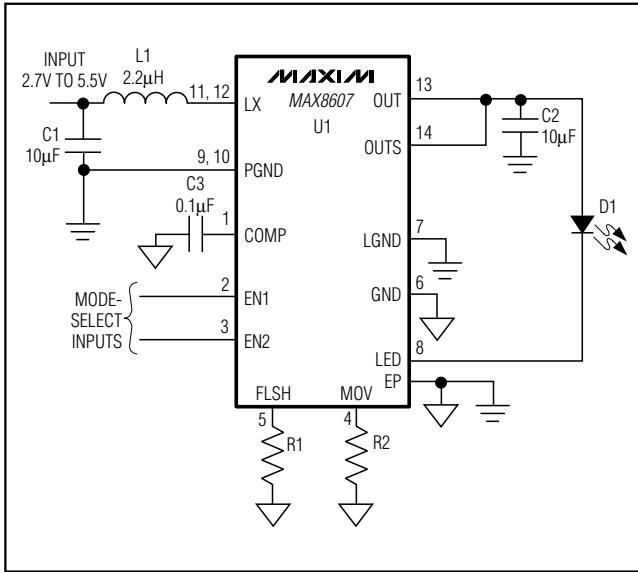

Figure 2. Typical Application Circuit

### Inductor Selection

The MAX8607 is designed to use a 2.2µH inductor. To prevent core saturation, ensure that the inductor-saturation current rating exceeds the peak inductor current for the application. Calculate the worst-case peak inductor current with the following formula:

$$I_{PEAK} = \frac{5V \times I_{LED(MAX)}}{0.9 \times V_{IN(MIN)}} + \frac{V_{IN(MIN)} \times 0.5\mu s}{2 \times 2.2\mu H}$$

Table 2 provides a list of suggested inductors.

**Table 2. Suggested Inductors**

MANUFACTURER	SERIES	INDUCTANCE (µH)	DCR (mΩ)	ISAT (A)	DIMENSIONS (LTYP x WTYP x HMAX = Volume)
Coilcraft	LPO3310	2.2	150	1.1	3.3 x 3.3 x 1.0 = 11mm <sup>3</sup>
Cooper (Coiltronics)	SD3114	2.2	83	1.48	3.0 x 3.0 x 1.45 = 13mm <sup>3</sup>
FDK	MIPF2520	2.2	80	0.7	2.5 x 2.0 x 1.0 = 5mm <sup>3</sup>
	MIPW3226	2.2	100	1.1	3.2 x 2.6 x 1.0 = 8mm <sup>3</sup>
TOKO	DE2812C	2.2	70	1.6	3.0 x 2.8 x 1.2 = 10mm <sup>3</sup>
	FDSE0312	2.2	160	2.3	3.0 x 3.0 x 1.2 = 11mm <sup>3</sup>

### Capacitor Selection

Bypass the input to PGND using a ceramic capacitor. Place the capacitor as close to the IC as possible. The exact value of the input capacitor is not critical. The typical value for the input capacitor is 10µF; however, larger value capacitors can be used to reduce input ripple at the expense of size and higher cost.

The output capacitance required depends on the required LED current. A 10µF ceramic capacitor works well in most situations, but a 4.7µF capacitor is acceptable for load current below 300mA.

### PC Board Layout

Due to fast switching waveforms and high-current paths, careful PC board layout is required. Connect GND directly to the exposed paddle underneath the IC; connect the exposed paddle to the PC board ground plane. Connect LGND and PGND to the ground plane. The output bypass capacitor should be placed as close to the IC as possible. CCOMP should be connected from COMP to GND as close to the IC as possible. Minimize trace lengths between the IC and the inductor, the input capacitor, and the output capacitor; keep these traces short, direct, and wide. The ground connections of CIN and COUT should be as close together as possible and connected to PGND. The traces from the input to the inductor and from the output capacitor to the LED may be longer. A sample layout is available in the MAX8607 evaluation kit (MAX8607EVKIT) to speed design.

### Chip Information

PROCESS: BiCMOS

# 1MHz PWM Boost Converter for 1.5A White LED Camera Flash

## Package Information

(The package drawing(s) in this data sheet may not reflect the most current specifications. For the latest package outline information, go to [www.maxim-ic.com/packages](http://www.maxim-ic.com/packages).)

**MAX8607**

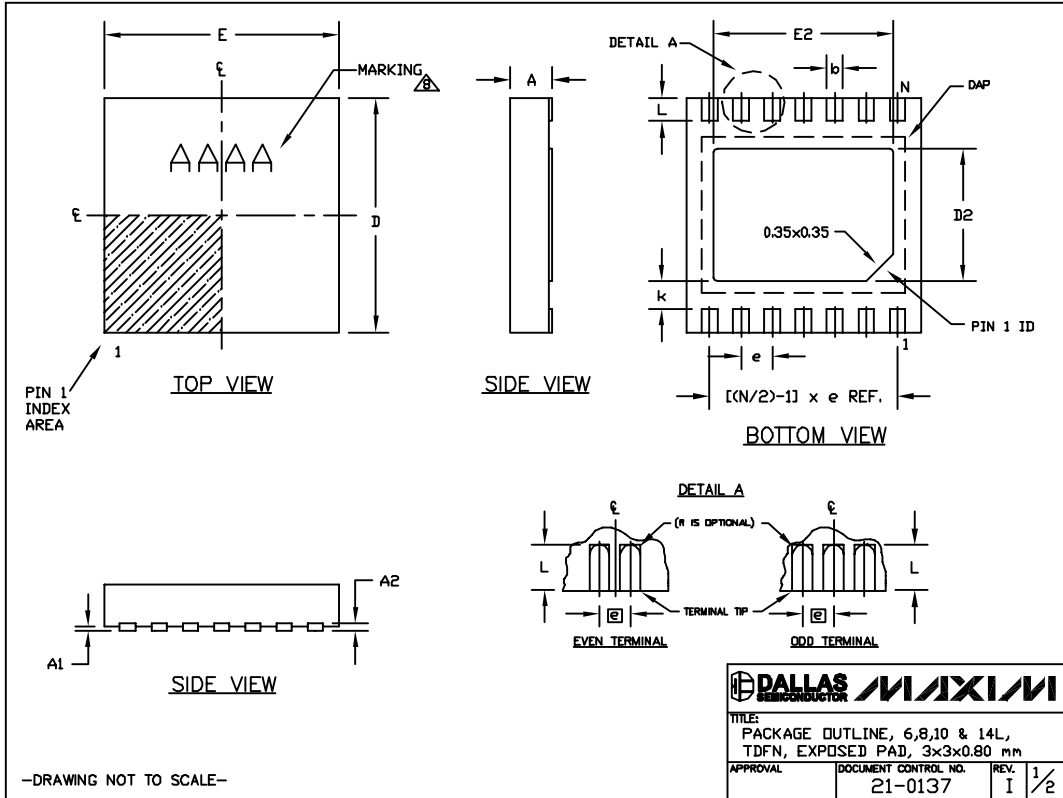

# 1MHz PWM Boost Converter for 1.5A White LED Camera Flash

## Package Information (continued)

(The package drawing(s) in this data sheet may not reflect the most current specifications. For the latest package outline information, go to [www.maxim-ic.com/packages](http://www.maxim-ic.com/packages).)

COMMON DIMENSIONS		
SYMBOL	MIN.	MAX.
A	0.70	0.80
D	2.90	3.10
E	2.90	3.10
A1	0.00	0.05
L	0.20	0.40
k	0.25 MIN.	
A2	0.20 REF.	

PACKAGE VARIATIONS								
PKG. CODE	N	D2	E2	e	JEDEC SPEC	b	[(N/2)-1] x e	
T633-2	6	1.50±0.10	2.30±0.10	0.95 BSC	MO229 / WEEA	0.40±0.05	1.90 REF	
T833-2	8	1.50±0.10	2.30±0.10	0.65 BSC	MO229 / WEEC	0.30±0.05	1.95 REF	
T833-3	8	1.50±0.10	2.30±0.10	0.65 BSC	MO229 / WEEC	0.30±0.05	1.95 REF	
T1033-1	10	1.50±0.10	2.30±0.10	0.50 BSC	MO229 / WEED-3	0.25±0.05	2.00 REF	
T1033-2	10	1.50±0.10	2.30±0.10	0.50 BSC	MO229 / WEED-3	0.25±0.05	2.00 REF	
T1433-1	14	1.70±0.10	2.30±0.10	0.40 BSC	----	0.20±0.05	2.40 REF	
T1433-2	14	1.70±0.10	2.30±0.10	0.40 BSC	----	0.20±0.05	2.40 REF	

### NOTES:

- ALL DIMENSIONS ARE IN mm. ANGLES IN DEGREES.
- COPLANARITY SHALL NOT EXCEED 0.08 mm.
- WARPAGE SHALL NOT EXCEED 0.10 mm.
- PACKAGE LENGTH/PACKAGE WIDTH ARE CONSIDERED AS SPECIAL CHARACTERISTIC(S).
- DRAWING CONFORMS TO JEDEC MO229, EXCEPT DIMENSIONS "D2" AND "E2", AND T1433-1 & T1433-2.
- "N" IS THE TOTAL NUMBER OF LEADS.
- NUMBER OF LEADS SHOWN ARE FOR REFERENCE ONLY.
-  MARKING IS FOR PACKAGE ORIENTATION REFERENCE ONLY.

—DRAWING NOT TO SCALE—

		
<b>TITLE:</b> PACKAGE OUTLINE, 6,8,10 & 14L, TDFN, EXPOSED PAD, 3x3x0.80 mm		
APPROVAL	DOCUMENT CONTROL NO.	REV.
	21-0137	I 2/2

## Revision History

Pages changed at Rev 1: 1, 2, 9, 10

Maxim cannot assume responsibility for use of any circuitry other than circuitry entirely embodied in a Maxim product. No circuit patent licenses are implied. Maxim reserves the right to change the circuitry and specifications without notice at any time.

10 \_\_\_\_\_ **Maxim Integrated Products, 120 San Gabriel Drive, Sunnyvale, CA 94086 408-737-7600**

## Looking for pricing, stock, or lifecycle information?

Click below to explore more details on WIN SOURCE:

 [View MAX8607ETD+T on WIN SOURCE](#)

 [Maxim Integrated](#) Information

## Optimize Your Supply Chain with WIN SOURCE Solutions

-  Global Sourcing Solution
-  Obsolete Management
-  Cost Control Management
-  Shortage Management
-  Alternative Solution
-  Excess Inventory Management