



**MAX8844Z/MAX8844Y****28V Dual Input Linear Li+ Battery Chargers with Battery Detection and Overvoltage-Protected Output****General Description**

The MAX8844Z/MAX8844Y intelligent, stand-alone constant-current, constant-voltage (CCCV), thermally regulated dual input linear chargers are designed for charging a single-cell lithium-ion (Li+) battery. The MAX8844Z/MAX8844Y integrates a current-sense circuit, MOSFET pass element, thermal-regulation circuitry, and eliminates the external reverse-blocking Schottky diode to create the simplest and smallest charging solutions for handheld equipment.

The IC controls the charging sequence from the prequalification state through constant current fast-charge, top-off charge, and full-charge indication. Proprietary thermal-regulation circuitry limits the die temperature during fast-charging or when the IC is exposed to high ambient temperatures, allowing maximum charging current without damaging the IC.

The MAX8844Z/MAX8844Y achieve high flexibility by providing adjustable fast-charge currents (SETI) and an adjustable top-off current threshold (MIN) through external resistors. The IC features a booting assistant circuit that distinguishes input sources and battery connection and provides an enable signal (ABO,  $\overline{\text{ABO}}$ ) for system booting.

The ICs also integrate two input overvoltage protected LDO outputs (SAFEOUT, SAFEUSB) for low voltage rated USB or charger inputs in system, and a battery pack detection circuit (DETBAT) that disables the charger when the battery pack is absent. Other features include an active-low control input ( $\overline{\text{EN}}$ ), an active-low input power source detection output (POK), and a fully charged top-off threshold detection output ( $\overline{\text{CHG}}$ ).

The MAX8844Z/MAX8844Y automatically select between either the USB or IN source. If both sources are present at the same time, highest priority is given to the IN source. The IN source is selected to insure the shortest charging time for the system since it is able to deliver the highest current.

The MAX8844Z/MAX8844Y accept an input supply range from 4.25V to 28V (IN and USB), but disables charging if the input voltage exceeds +7.5V to protect against unqualified or faulty AC adapters. The ICs operate over the extended temperature range (-40°C to +85°C) and are available in a compact 14-pin, thermally enhanced TDFN 3mm x 3mm package (0.8mm max height).

**Applications**

- Cellular and Cordless Phones
- Smart Phones and PDAs
- Digital Still Cameras
- MP3 Players
- USB Appliances
- Charging Cradles and Docks
- Bluetooth® Equipment

Bluetooth is a registered trademark of Bluetooth SIG.

**Features**

- CCCV, Thermally Regulated Linear One-Cell Li+ Battery Charger
- No External MOSFET, Reverse Blocking Diode, or Current-Sense Resistor
- Programmable Fast-Charge Currents (1A<sub>RMS</sub> max)
- Programmable Top-Off Current Threshold
- Input Overvoltage Protected 4.7V Output (SAFEOUT) from IN
- Input Overvoltage Protected 4.7V Output (SAFEUSB) from USB
- Proprietary Die Temperature Regulation Control (+115°C)
- 4.25V to 28V Input Voltage Range with Input Overvoltage Protection Above +7.5V
- Low-Dropout Voltage (300mV at 500mA)
- Input Power-Source Detection Output ( $\overline{\text{POK}}$ ), Charge Status Output ( $\overline{\text{CHG}}$ ), Charge-Enable Input ( $\overline{\text{EN}}$ )
- Output for Autoboosting (ABO, MAX8844Z)
- Output for Autoboosting ( $\overline{\text{ABO}}$ , MAX8844Y)
- Tiny 3mm x 3mm, 14-Pin TDFN Package, 0.8mm Height (max)

**Ordering Information**

PART	PIN-PACKAGE	TOP MARK	ABO ACTIVE STATE
MAX8844ZETD+	14 TDFN-EP* 3mm x 3mm	AEK	Active high
MAX8844YETD+	14 TDFN-EP* 3mm x 3mm	AEN	Active low

+Denotes a lead(Pb)-free/RoHS-compliant package.

\*EP = Exposed pad.

**Note:** All devices are specified over the -40°C to +85°C operating temperature range.

**Typical Operating Circuit and Pin Configuration appear at end of data sheet.**



**Absolute Maximum Ratings**

IN, USB to GND .....-0.3V to +30V  
 ABI, BATT, EN, POK, ABO, ABO, CHG, DETBAT, SETI,  
 MIN, SAFEOUT,  
 SAFEUSB to GND .....-0.3V to +6V  
 IN to BATT Continuous Current .....1A<sub>RMS</sub>  
 Continuous Power Dissipation (T<sub>A</sub> = +70°C)  
 14-TDFN (derate 24.4mW/°C above 70°C)  
 (multilayer PCB) .....1951.2mW  
 BATT Short-Circuit Duration ..... Continuous  
 Operating Temperature Range ..... -40°C to +85°C

Junction Temperature .....+150°C  
 Storage Temperature Range ..... -65°C to +150°C  
 Lead Temperature (soldering, 10s) .....+300°C

*Stresses beyond those listed under "Absolute Maximum Ratings" may cause permanent damage to the device. These are stress ratings only, and functional operation of the device at these or any other conditions beyond those indicated in the operational sections of the specifications is not implied. Exposure to absolute maximum rating conditions for extended periods may affect device reliability.*

**Electrical Characteristics**

(V<sub>IN</sub> = 5V or V<sub>USB</sub> = 5V, V<sub>BATT</sub> = 4V, R<sub>POK</sub> = 1MΩ to BATT, EN = unconnected, R<sub>SETI</sub> = 2.8kΩ to GND, V<sub>DETBAT</sub> = 0V, C<sub>BATT</sub> = 2.2μF, T<sub>A</sub> = -40°C to +85°C, unless otherwise noted. Typical values are at T<sub>A</sub> = +25°C.) (Note 1)

PARAMETER	CONDITIONS	MIN	TYP	MAX	UNITS	
<b>IN, USB</b>						
Input Supply Voltage Range		0		28	V	
Input Supply Operating Voltage Range		4.25		7.00	V	
Overvoltage Lockout Trip Threshold	V <sub>IN</sub> rising, 100mV hysteresis (typ)	7.0	7.5	8.0	V	
Input Current	Constant current charging I <sub>IN</sub> - I <sub>BATT</sub> , I <sub>BATT</sub> = 0A		0.25	0.50	mA	
	Constant current charging I <sub>IN</sub> - I <sub>BATT</sub> , I <sub>BATT</sub> = 500mA		1			
	IC disabled, V <sub>EN</sub> = 5V		0.23	0.50		
	V <sub>IN</sub> = 4V, V <sub>BATT</sub> = 4.2V	T <sub>A</sub> = +25°C T <sub>A</sub> = +85°C		0.02 0.03		
<b>BATT, CHG, POK</b>						
Minimum BATT Bypass Capacitance			2.2		μF	
V <sub>BATT</sub> Prequalification Threshold Voltage	V <sub>BATT</sub> rising, 100mV hysteresis (typ)	2.3	2.5	2.7	V	
Battery Regulation Voltage	I <sub>BATT</sub> = 0A	T <sub>A</sub> = 0°C to +85°C	4.175	4.200	4.225	V
		T <sub>A</sub> = -40°C to +85°C	4.158	4.200	4.242	
Regulator Dropout Voltage (V <sub>IN</sub> - V <sub>BATT</sub> )	V <sub>BATT</sub> = 4.1V, I <sub>BATT</sub> = 425mA		260		mV	
BATT Input Current (Note 2)	V <sub>IN</sub> = 0 to 4V, V <sub>BATT</sub> = 4.2V		5	10	μA	
	IC disabled		3			
Current-Sense Amplifier Gain (I <sub>BATT</sub> to I <sub>SETI</sub> )	I <sub>BATT</sub> = 500mA	T <sub>A</sub> = 0°C to +85°C		1120	μA/A	
		T <sub>A</sub> = -40°C to +85°C		1120		

**Electrical Characteristics (continued)**

( $V_{IN} = 5V$  or  $V_{USB} = 5V$ ,  $V_{BATT} = 4V$ ,  $R_{\overline{POK}} = 1M\Omega$  to BATT,  $\overline{EN} =$  unconnected,  $R_{SETI} = 2.8k\Omega$  to GND,  $V_{DETBAT} = 0V$ ,  $C_{BATT} = 2.2\mu F$ ,  $T_A = -40^\circ C$  to  $+85^\circ C$ , unless otherwise noted. Typical values are at  $T_A = +25^\circ C$ .) (Note 1)

PARAMETER	CONDITIONS		MIN	TYP	MAX	UNITS
Fast-Charge Current	$V_{BATT} = 3.5V$ , $R_{SETI} = 2.8k\Omega$	$T_A = 0^\circ C$ to $+85^\circ C$	400	440	480	mA
		$T_A = -40^\circ C$ to $+85^\circ C$	375	440	505	
	$V_{BATT} = 3.5V$ , $R_{SETI} = 14k\Omega$		74	88	102	
USB Fast-Charge Current	MAX8844Z		332	380	418	mA
	MAX8844Y		405	450	495	
$\overline{CHG}$ Top-Off Threshold (Note 3)	$I_{BATT}$ falling, battery is charged, $R_{MIN} = 1.75k\Omega$			99		mA
$\overline{CHG}$ Hysteresis	$I_{BATT}$ rising after top-off is detected, $R_{MIN} = 1.75k\Omega$			27		mA
$\overline{CHG}$ Detection Delay	$I_{BATT}$ falls below top-off threshold		4.0	6.2	10.7	ms
Prequalification Charge Current	Percentage of the fast-charge current, $V_{BATT} = 2.2V$ , $T_A = 0^\circ C$ to $+85^\circ C$		5	11	17	%
$\overline{CHG}$ , $\overline{POK}$ Output Low Threshold	$I_{\overline{POK}} = 5mA$ , $I_{\overline{CHG}} = 5mA$				0.4	V
$\overline{CHG}$ , $\overline{POK}$ Output High Leakage Current	$V_{\overline{POK}} = 5.5V$ , $V_{\overline{CHG}} = 5.5V$	$T_A = +25^\circ C$			1	$\mu A$
		$T_A = +85^\circ C$			0.002	
POK Threshold (Note 2)	$V_{IN} - V_{BATT}$	$V_{IN}$ rising		40		mV
		$V_{IN}$ falling		30		
<b>DETBAT, SAFEOUT, SAFEUSB</b>						
DETBAT Logic Input Low Threshold					0.4	V
DETBAT Logic Input High Threshold			1.3			
DETBAT Pullup Resistor	DETBAT to VL = 3V			470		k $\Omega$
Minimum SAFEOUT Bypass Capacitance				1		$\mu F$
SAFEOUT Regulated Output	$I_{SAFEOUT} = 30mA$ , $V_{IN} = 5V$ , $T_A = 0^\circ C$ to $+85^\circ C$		4.5	4.7	4.9	V
SAFEOUT Current Limit				100		mA
Minimum SAFEUSB Bypass Capacitance				1		$\mu F$
SAFEUSB Regulated Output	$I_{SAFEUSB} = 30mA$ , $V_{USB} = 5V$ , $T_A = 0^\circ C$ to $+85^\circ C$		4.5	4.7	4.9	V
SAFEUSB Current Limit				100		mA
<b><math>\overline{EN}</math>, ABI, ABO, <math>\overline{ABO}</math></b>						
$\overline{EN}$ , ABI Internal Pulldown Resistor			100	200	400	k $\Omega$
$\overline{EN}$ , Logic Input Low Threshold (Note 2)	$4.25V \leq V_{IN} \leq 7V$				0.4	V
$\overline{EN}$ , Logic Input High Theshold (Note 2)	$4.25V \leq V_{IN} \leq 7V$		1.3			V

**Electrical Characteristics (continued)**

( $V_{IN} = 5V$  or  $V_{USB} = 5V$ ,  $V_{BATT} = 4V$ ,  $R_{\overline{POK}} = 1M\Omega$  to BATT,  $\overline{EN} =$  unconnected,  $R_{SET1} = 2.8k\Omega$  to GND,  $V_{DET\overline{BAT}} = 0V$ ,  $C_{BATT} = 2.2\mu F$ ,  $T_A = -40^\circ C$  to  $+85^\circ C$ , unless otherwise noted. Typical values are at  $T_A = +25^\circ C$ .) (Note 1)

PARAMETER	CONDITIONS	MIN	TYP	MAX	UNITS
ABI Logic Input Low Threshold	$V_{BATT} = 4V$ , $V_{IN} = 0V$			0.4	V
ABI Logic Input High Threshold	$V_{BATT} = 4V$ , $V_{IN} = 0V$	1.3			V
ABO Output Low Threshold	$I_{ABO(SINK)} = 1mA$			0.4	V
ABO Output High Threshold	$I_{ABO(SOURCE)} = 1mA$	$V_{BATT} - 0.4V$			V
$\overline{ABO}$ Output Low Threshold	Open drain, $I_{\overline{ABO}(SINK)} = 1mA$			0.4	
$\overline{ABO}$ Output High Threshold	Open drain, 100k $\Omega$ pullup on BATT	$V_{BATT} - 0.4V$			
<b>THERMAL</b>					
Die Temperature Regulation Threshold			115		$^\circ C$

- Note 1:** Specifications are 100% production tested at  $T_A = +25^\circ C$ . Limits over the operating temperature range are guaranteed by design and characterization.
- Note 2:** The IN input supply and USB input supply are interchangeable ( $V_{IN} = V_{USB}$ ). See the *DC and USB Power Supplies* section for further details.
- Note 3:** See the *Top-Off Current Threshold Setting* section for further details.

**Typical Operating Characteristics**

( $V_{IN} = 5V$  or  $V_{USB} = 5V$ ,  $V_{BATT} = 4V$ ,  $R_{\overline{POK}} = R_{CHG} = 200k\Omega$  to 5V,  $\overline{EN} =$  unconnected,  $R_{SET1} = 2.8k\Omega$  to GND,  $R_{MIN} = 1.74k\Omega$  to GND,  $R_{DET\overline{BAT}} = 4.7k\Omega$  to GND,  $C_{BATT} = 2.2\mu F$ ,  $T_A = +25^\circ C$ , unless otherwise noted.)

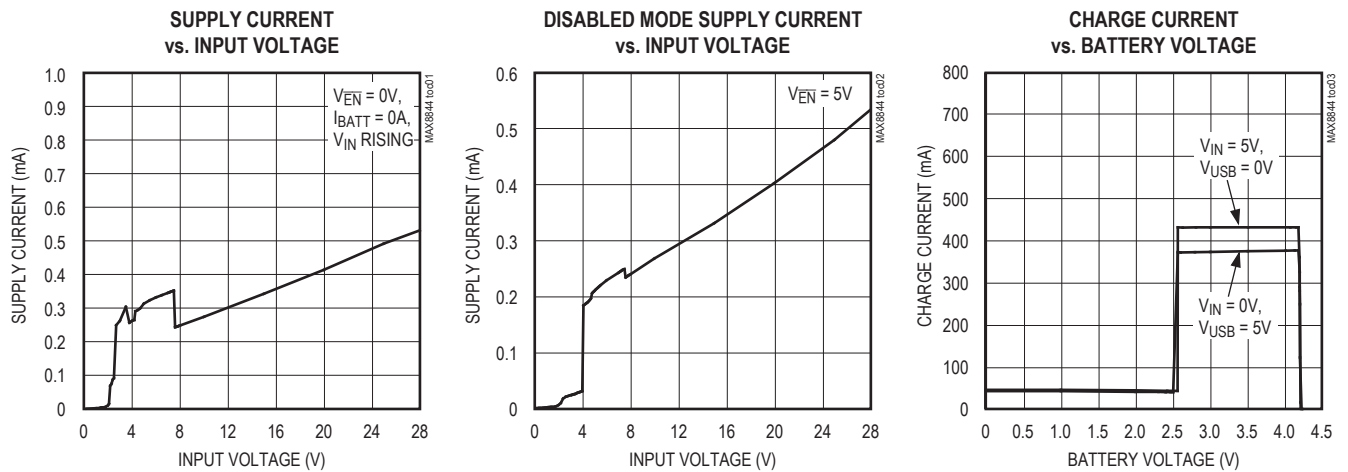

Typical Operating Characteristics (continued)

( $V_{IN} = 5V$  or  $V_{USB} = 5V$ ,  $V_{BATT} = 4V$ ,  $R_{POK} = R_{CHG} = 200k\Omega$  to  $5V$ ,  $\overline{EN}$  = unconnected,  $R_{SET1} = 2.8k\Omega$  to GND,  $R_{MIN} = 1.74k\Omega$  to GND,  $R_{DETBAT} = 4.7k\Omega$  to GND,  $C_{BATT} = 2.2\mu F$ ,  $T_A = +25^\circ C$ , unless otherwise noted.

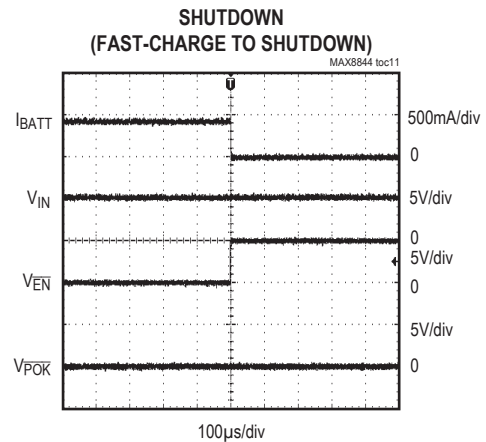
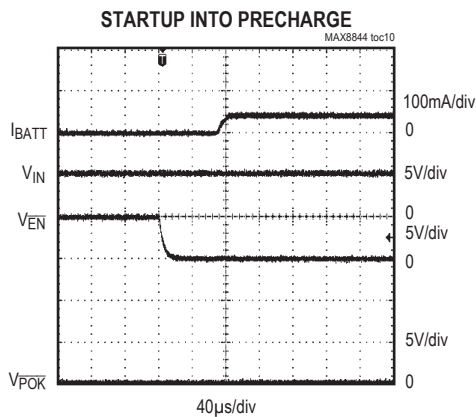
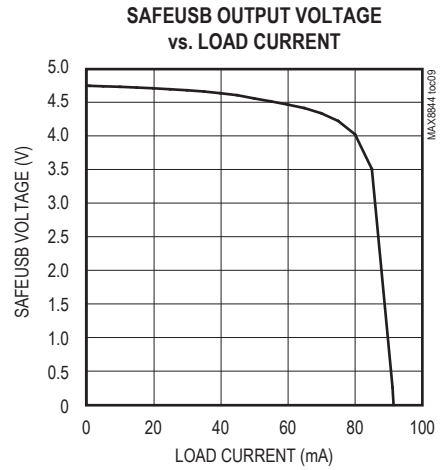
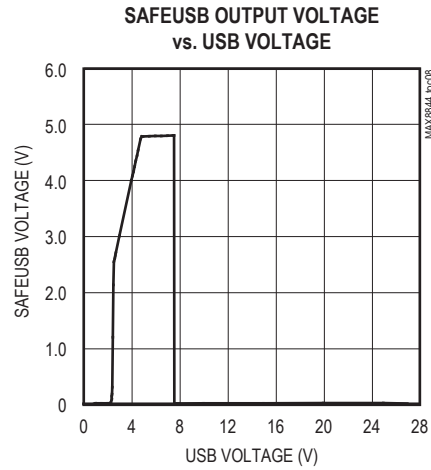
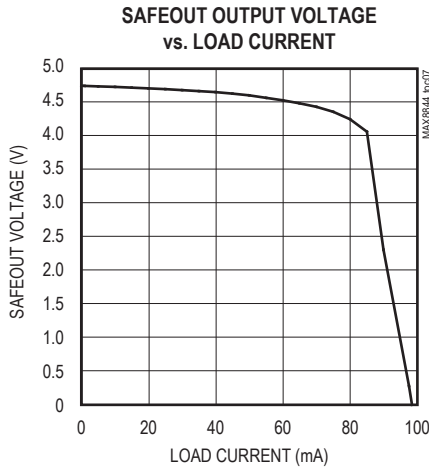
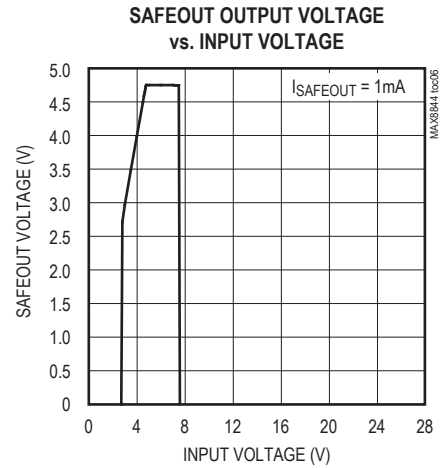
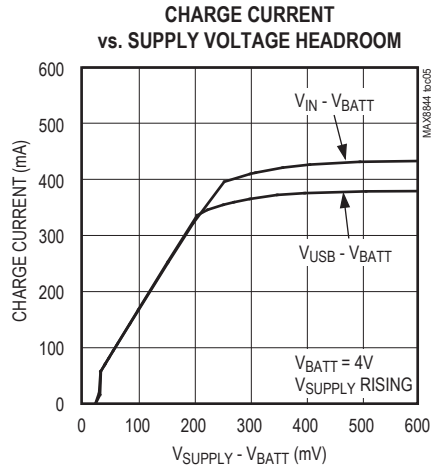
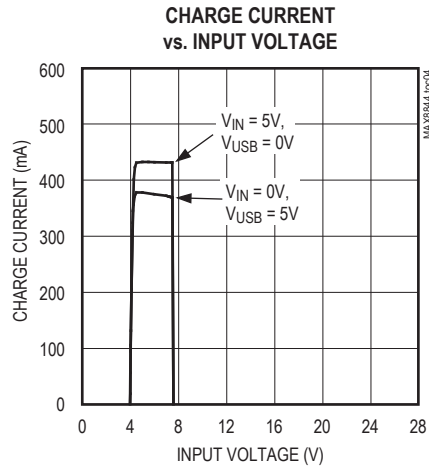

Typical Operating Characteristics (continued)

( $V_{IN} = 5V$  or  $V_{USB} = 5V$ ,  $V_{BATT} = 4V$ ,  $R_{POK} = R_{CHG} = 200k\Omega$  to  $5V$ ,  $\overline{EN}$  = unconnected,  $R_{SET1} = 2.8k\Omega$  to GND,  $R_{MIN} = 1.74k\Omega$  to GND,  $R_{DETBAT} = 4.7k\Omega$  to GND,  $C_{BATT} = 2.2\mu F$ ,  $T_A = +25^\circ C$ , unless otherwise noted.)

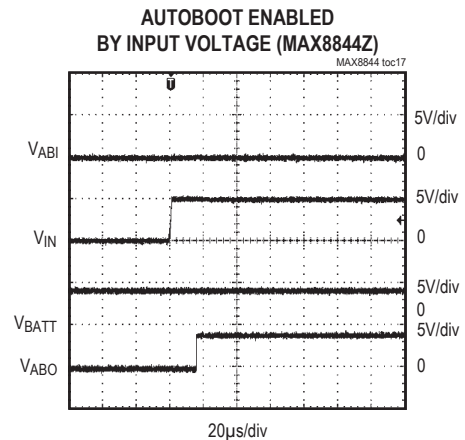
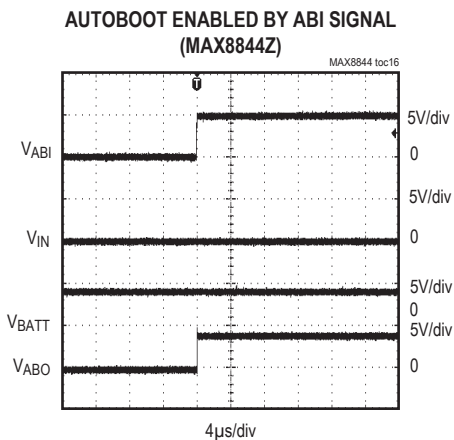
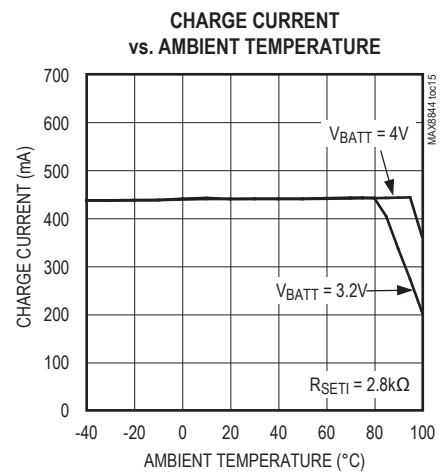
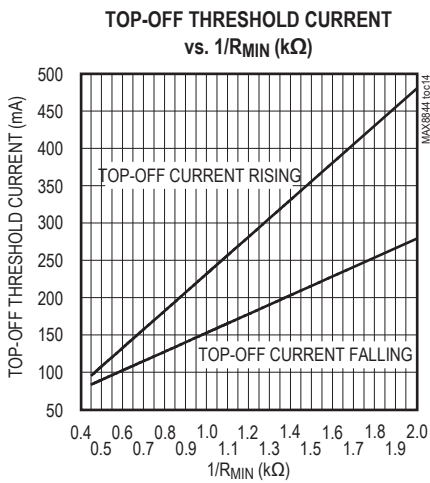
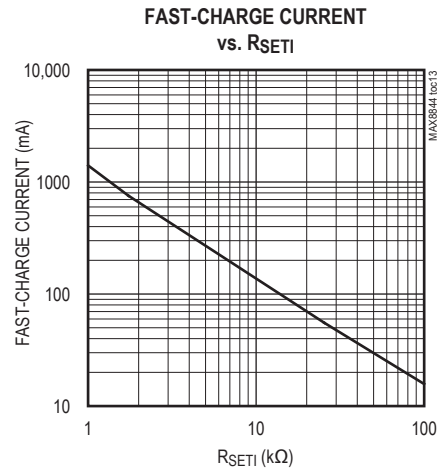
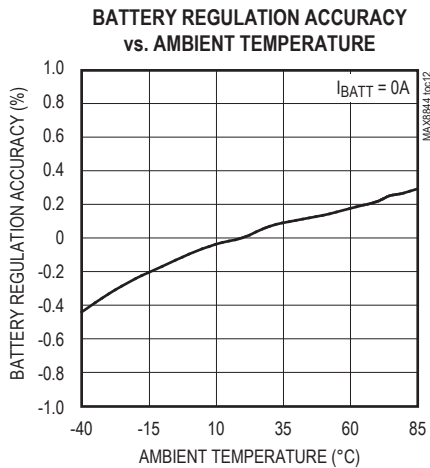

## Pin Description

PIN		NAME	FUNCTION
MAX8844Z	MAX8844Y		
1	1	IN	Input Supply Voltage. IN is the power supply for the SAFEOUT linear regulator and the battery charger. See the <i>DC and USB Power Supplies</i> section. Bypass IN to GND with a 1µF or larger ceramic capacitor to improve line noise and input transient rejection.
2	2	$\overline{\text{POK}}$	Active-Low, Input Voltage Status Indicator. $\overline{\text{POK}}$ is an open-drain output that asserts low when $2.35\text{V} < (V_{\text{IN}} \text{ or } V_{\text{USB}}) < 7\text{V}$ and $[(V_{\text{IN}} \text{ or } V_{\text{USB}}) - V_{\text{BATT}}] \geq 40\text{mV}$ . If $(V_{\text{IN}} \text{ or } V_{\text{USB}}) > +7.5\text{V}$ or $V_{\text{BATT}} > (V_{\text{IN}} \text{ or } V_{\text{USB}})$ , the IC is shut down and $\overline{\text{POK}}$ becomes high impedance. Connect a pullup resistor to the microprocessor's I/O voltage when interfacing with a microprocessor logic input.
3	3	USB	USB Input Supply Voltage. USB is the power supply for the SAFEUSB linear regulator and the battery charger. See the <i>DC and USB Power Supplies</i> section. Bypass USB to GND with a 1µF or larger ceramic capacitor to improve line noise and input transient rejection.
4	4	ABI	Autobooting External Input. See the <i>Autobooting Assistant</i> section and Table 1 for autobooting conditions. ABI is pulled to GND through an internal 200kΩ resistor.
5	—	ABO	Active-High, Autobooting Logic Output. See the <i>Autobooting Assistant</i> section and Table 1 for autobooting conditions.
—	5	$\overline{\text{ABO}}$	Active-Low, Autobooting Logic Output. See the <i>Autobooting Assistant</i> section and Table 1 for autobooting conditions.
6	6	MIN	Top-Off Current Threshold Programmable Input. $I_{\text{MIN}} \text{ (mA) falling} = 126\text{V}/R_{\text{MIN}} \text{ (k}\Omega) + 27 \text{ (mA)}$ .
7	7	SETI	Charge-Current Program and Fast-Charge Current Monitor. Output current from SETI is 1120µA per ampere of battery charging current. Set the charging current by connecting a resistor ( $R_{\text{SETI}}$ in Figure 3) from SETI to GND. $I_{\text{FAST-CHARGE}} = 1250\text{V}/R_{\text{SETI}}$ . To configure the MAX8844Z/MAX8844Y as a USB charger, see Figure 5.
8	8	DETBAT	Battery Pack ID Resistor Detection Input. If DETBAT is pulled low through a pulldown resistor less than 51kΩ, the charger is enabled. If DETBAT is left unconnected, the charger is disabled.
9	9	$\overline{\text{CHG}}$	Active-Low, Charging Indicator. $\overline{\text{CHG}}$ is an open-drain output that is pulled low once charging begins. $\overline{\text{CHG}}$ is high impedance when the battery current drops below MIN, or when the IC is disabled. Connect a pullup resistor to the microprocessor's I/O voltage when interfacing with a microprocessor logic input.
10	10	$\overline{\text{EN}}$	Active-Low, Logic-Level Enable Input. Drive $\overline{\text{EN}}$ high to disable charger. Drive $\overline{\text{EN}}$ low or leave unconnected for normal operation. $\overline{\text{EN}}$ has an internal 200kΩ pulldown resistor.
11	11	GND	Ground. Connect GND and the exposed pad to a large copper ground plane for maximum power dissipation. Connect GND to the exposed pad directly under the IC.
12	12	BATT	Li+ Battery Connection. Bypass BATT to GND with a 2.2µF ceramic capacitor.
13	13	SAFEUSB	4.7V Regulated LDO Output with Input Overvoltage Protection. Bypass SAFEUSB to GND with a 1µF or larger ceramic capacitor. SAFEUSB can be used to supply low voltage rated USB systems.

Pin Description (continued)

PIN		NAME	FUNCTION
MAX8844Z	MAX8844Y		
14	14	SAFEOUT	4.7V Regulated LDO Output with Input Overvoltage Protection. Bypass SAFEOUT to GND with a 1µF or larger ceramic capacitor. SAFEOUT can be used to supply low voltage rated charging systems.
—	—	EP	Exposed Pad. Connect the exposed pad to a large ground plane for maximum power dissipation. Connect GND to the exposed pad directly under the IC.

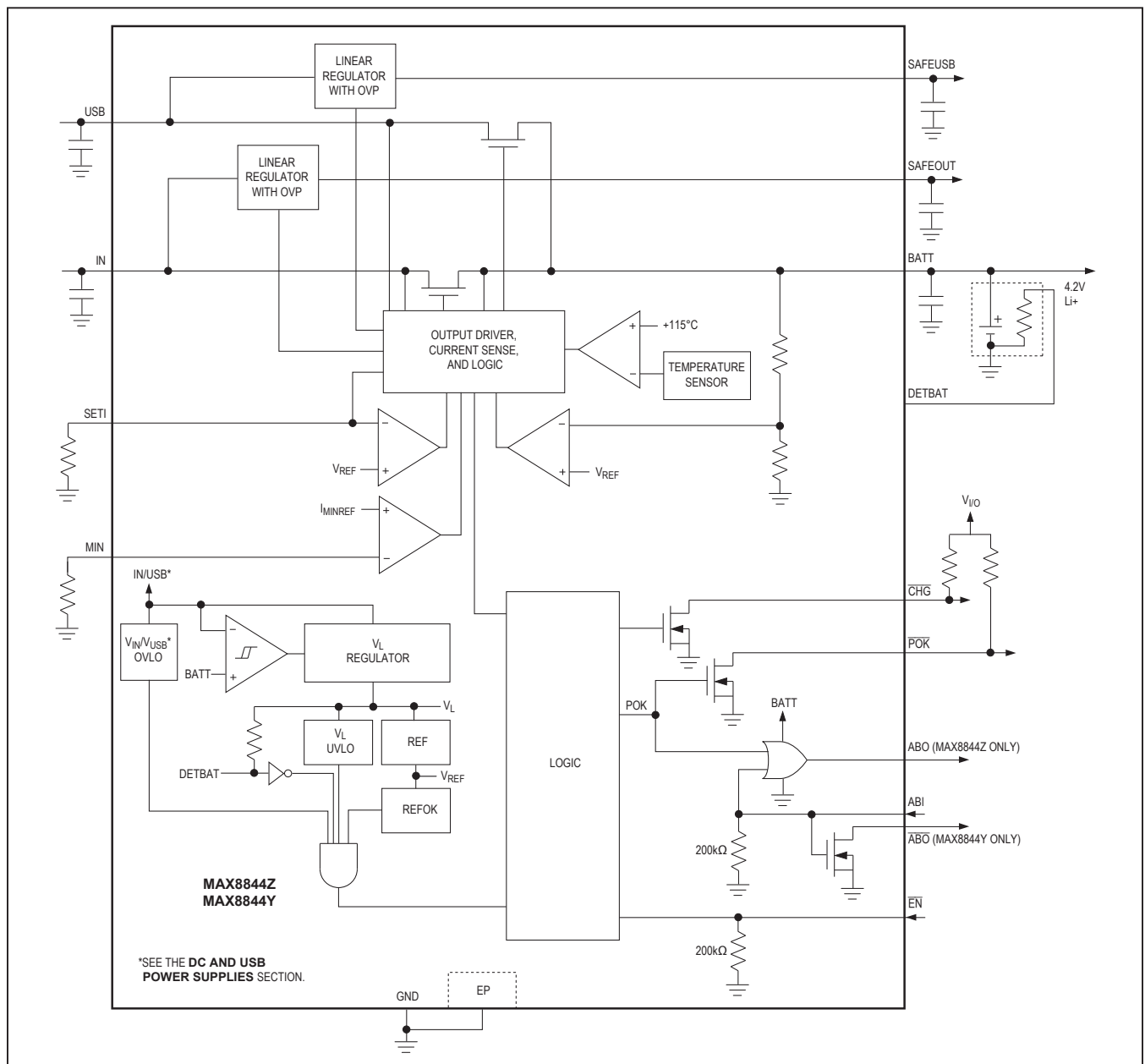

Figure 1. Functional Diagram

**Detailed Description**

The MAX8844Z/MAX8844Y chargers use voltage, current, and thermal-control loops to charge a single Li+ cell and protect the battery (Figure 1). When a Li+ battery with a cell voltage below 2.5V is inserted, the MAX8844Z/MAX8844Y chargers enter a prequalification stage where it precharges that cell with 10% of the user-programmed fast-charge current (Figure 2). The  $\overline{\text{CHG}}$  indicator is driven low to indicate entry into the prequalification state. When the battery voltage exceeds 2.5V, the charger soft-starts as it enters the fast-charge stage. The fast-charge current level is programmed through a resistor from SET1 to GND. As the battery voltage approaches 4.2V, the battery current is reduced. If the battery current drops to less than then top-off current threshold set by  $R_{\text{MIN}}$ , the charger enters top-off mode and the  $\overline{\text{CHG}}$  indicator goes high impedance signaling that the battery is fully charged.

**Overvoltage Protected Output (SAFEOUT)**

SAFEOUT is a linear regulator that provides an output voltage of 4.7V and can be used to supply low voltage rated charging systems. The SAFEOUT linear regulator

turns on when  $V_{\text{IN}} \geq 4.25\text{V}$  regardless of  $\overline{\text{EN}}$  and is disabled when  $V_{\text{IN}}$  is greater than the overvoltage threshold (7.5V typ).

**Overvoltage Protected Output (SAFEUSB)**

SAFEUSB is a linear regulator that provides an output voltage of 4.7V and can be used to supply low voltage rated USB systems. The SAFEUSB linear regulator turns on when  $V_{\text{USB}} \geq 4.25\text{V}$  regardless of  $\overline{\text{EN}}$  and is disabled when  $V_{\text{USB}}$  is greater than the overvoltage threshold (7.5V typ).

**Battery Pack Detection Input (DETBAT)**

DETBAT is a battery pack ID resistor detector that enables the battery charger if pulled low through a resistor that is less than 51kΩ. If DETBAT is left unconnected or the pulldown resistor is 51kΩ or greater the battery charger is disabled.

**$\overline{\text{POK}}$  Output**

The open-drain  $\overline{\text{POK}}$  output asserts low when  $2.35\text{V} \leq (V_{\text{IN}} \text{ or } V_{\text{USB}}) \leq 7\text{V}$  and  $[(V_{\text{IN}} \text{ or } V_{\text{USB}}) - V_{\text{BATT}}] \geq 40\text{mV}$  (typ  $V_{\text{IN}}$  or  $V_{\text{USB}}$  rising).  $\overline{\text{POK}}$  is high impedance during

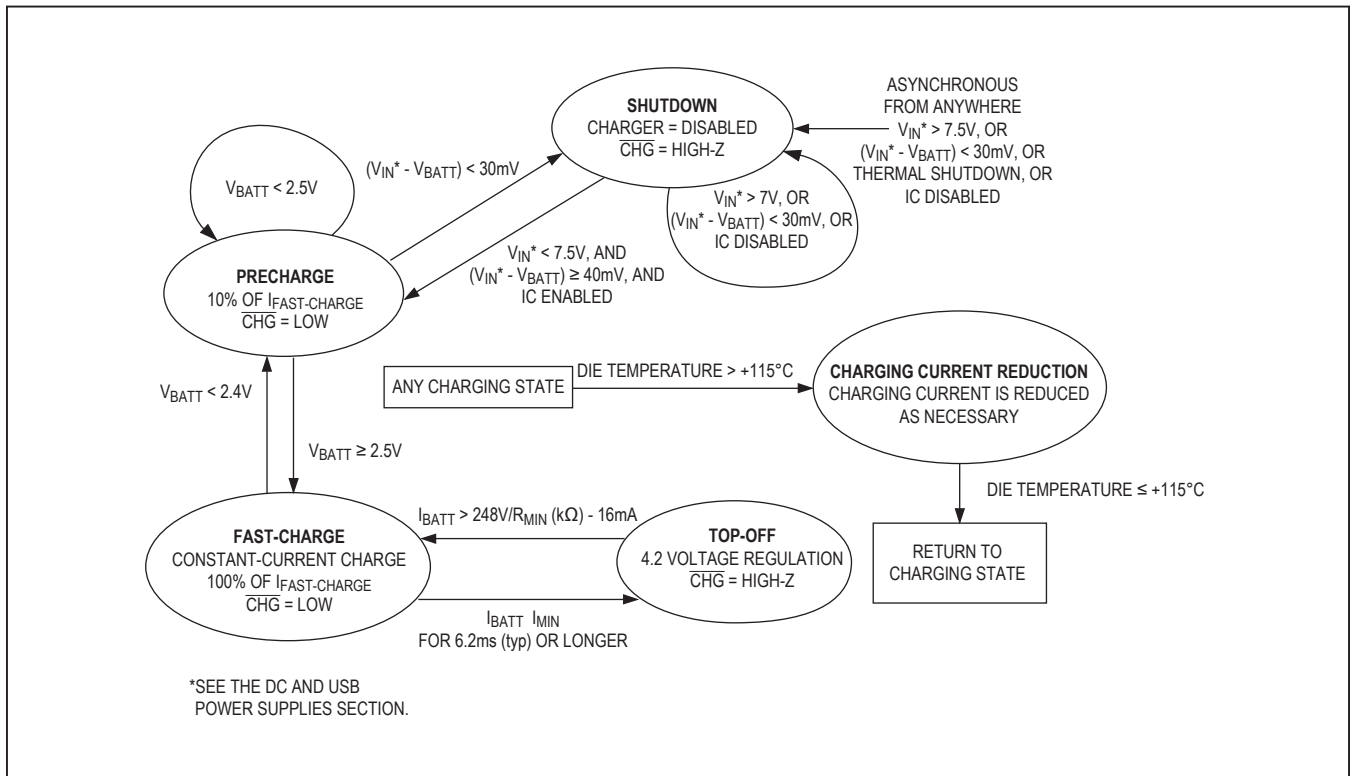

Figure 2. Charge-State Diagram

**Table 1. Autoboosting Output States**

ABI	BATT	POK	CHARGER STATE	ABO (MAX8844Z)	$\overline{\text{ABO}}$ (MAX8844Y)
Low	Present	High-Z	Shutdown	Low	High-Z
High	Present	High-Z	Shutdown	High	Low
Low	Not present	Low	CC/CV mode	High	High-Z
Low	Present	Low	Fast-charge/top-off	High	High-Z
High	Present	Low	Fast-charge/top-off	High	Low

**Note:** Present indicates that  $V_{\text{BATT}} \geq 2.0\text{V}$  and Not Present indicates that the battery is not connected.

shutdown. When interfacing with a microprocessor logic input, a pullup resistor to the microprocessor's I/O voltage may be required. If DETBAT is not used, connect DETBAT to GND for normal operation.

### Autoboosting Assistant

The MAX8844Z/MAX8844Y contain an autoboosting assistant circuit that generates an enable signal for system booting (ABO,  $\overline{\text{ABO}}$ ). For the MAX8844Z, the booting assistant functions as an internal OR gate (Figure 1). The first input is dependant on the input supply voltage ( $V_{\text{IN}}$  or  $V_{\text{USB}}$ ) and DETBAT while the second input is an external signal applied to ABI. The first input (POK) is driven high once DETBAT is pulled low through a resistor less than 51k $\Omega$ ,  $2.35\text{V} \leq (V_{\text{IN}}$  or  $V_{\text{USB}}) \leq 7\text{V}$ , and  $[(V_{\text{IN}}$  or  $V_{\text{USB}}) - V_{\text{BATT}}] \geq 40\text{mV}$  (typ  $V_{\text{IN}}$  rising).

The second input signal (ABI) is driven by an external source (Table 1). ABI enables an autoboot signal when a battery is connected at BATT and is independent of  $\overline{\text{POK}}$ . If  $\overline{\text{POK}}$  is pulled low, the booting assistant always drives ABO high regardless of ABI. ABI is pulled to GND through an internal 200k $\Omega$  resistor. If ABI is supplied from an out-

side exposed pin, a RC filter (Figure 4) is required for ESD protection and noise filtering. If ABI is supplied by a system's internal GPIO, or logic, the RC filter is not required.

For the MAX8844Y, the output  $\overline{\text{ABO}}$  is only dependent on the state of ABI (Table 1).

### CHG Charge Indicator Output

$\overline{\text{CHG}}$  is an open-drain output that indicates charge status. Table 2 describes the state of  $\overline{\text{CHG}}$  during different stages of operation.  $\overline{\text{CHG}}$  is suitable for driving a charge indication LED. If the MAX8844Z/MAX8844Y are used in conjunction with a microprocessor, a pullup resistor to the logic I/O voltage allows CHG to indicate charge status to the microprocessor instead of driving an LED.

### Thermal Regulation

The thermal-regulation loop limits the MAX8844Z/MAX8844Y die temperatures to +115°C by reducing the charge current as necessary. This feature not only protects the IC from overheating, but also allows a higher charge current without risking damage to the system.

**Table 2.  $\overline{\text{CHG}}$  States**

EN	$V_{\text{IN}}^*$	$V_{\text{BATT}}$	$I_{\text{BATT}}$	$\overline{\text{CHG}}$	STATE
High	X	X	0	High-Z	Disabled
Low	> 7.5V	X	0	High-Z	Shutdown
	X	> $V_{\text{IN}}^* - 30\text{mV}$			
Low	$4.25\text{V} \leq V_{\text{IN}}^* \leq 7.5\text{V}$	< 2.4V	10% of $I_{\text{FAST-CHARGE}}^\dagger$	Low	Precharge
Low	$4.25\text{V} \leq V_{\text{IN}}^* \leq 7.5\text{V}$	$\geq 2.5\text{V}$	100% of $I_{\text{FAST-CHARGE}}^\dagger$	Low	Fast-charge
Low	$4.25\text{V} \leq V_{\text{IN}}^* \leq 7.5\text{V}$	4.2V	< $I_{\text{MIN}}$	High-Z	Top-off

X = Don't care.

\* $V_{\text{IN}}$  and  $V_{\text{USB}}$  are interchangeable. See the DC and USB Power Supplies section.

† $I_{\text{FAST-CHARGE}}$  is reduced as necessary to prevent the die temperature from exceeding +115°C.

### Charger Enable Input

The MAX8844Z/MAX8844Y contain an active-low logic input ( $\overline{\text{EN}}$ ) used to enable the chargers. Drive  $\overline{\text{EN}}$  low, leave unconnected, or connect to GND to enable the charge-control circuitry. Drive  $\overline{\text{EN}}$  high to disable the charger-control circuitry.  $\overline{\text{EN}}$  has an internal 200k $\Omega$  pull-down resistor.

### Soft-Start

The soft-start algorithm activates when entering fast-charge mode. When the prequalification state is complete ( $V_{\text{BATT}}$  exceeds +2.5V), the charging current ramps up in 250 $\mu\text{s}$  to the full charging current. This reduces the inrush current demand on the input supply.

## Applications Information

### Fast-Charge Current Setting

The maximum charging current is programmed by an external resistor connected from SETI to GND ( $R_{\text{SETI}}$ ). Use the following equation to determine the fast-charge current ( $I_{\text{FAST-CHARGE}}$ ):

$$I_{\text{FAST-CHARGE}} = \frac{1250\text{V}}{R_{\text{SETI}}}$$

where  $I_{\text{FAST-CHARGE}}$  is in amps and  $R_{\text{SETI}}$  is in ohms.  $R_{\text{SETI}}$  must always be 1.25k $\Omega$  or higher due to the continuous charging current limit of 1A $_{\text{RMS}}$ .

### Top-Off Current Threshold Setting

The top-off current threshold is programmed by an external resistor connected from MIN to GND ( $R_{\text{MIN}}$ ). Use the following equation to determine the top-off current ( $I_{\text{MIN}}$ ):

$$I_{\text{MIN}} (\text{falling}) = 126\text{V}/R_{\text{MIN}} (\text{k}\Omega) + 27\text{mA}$$

$$I_{\text{MIN}} (\text{rising}) = 248\text{V}/R_{\text{MIN}} (\text{k}\Omega) - 16\text{mA}$$

where  $I_{\text{MIN}}$  is in mA and  $R_{\text{MIN}}$  is in k $\Omega$ . Use  $R_{\text{MIN}} \leq 2.2\text{k}\Omega$ .

### Capacitor Selection

Connect a ceramic capacitor from BATT to GND for proper stability. Use a 2.2 $\mu\text{F}$  ceramic capacitor for most applications. Connect 1 $\mu\text{F}$  ceramic capacitors from IN to GND and from USB to GND. A larger input capacitor can be used for high charging current to reduce input voltage ripple.

Connect 1 $\mu\text{F}$  ceramic capacitors from SAFEOUT to GND and from SAFEUSB to GND. A larger bypass capacitor for SAFEOUT and SAFEUSB can be used for optimum noise immunity. Ceramic capacitors with X5R or X7R dielectric are highly recommended due to their small size, low ESR, and small temperature coefficients.

### Thermal Considerations

The MAX8844Z/MAX8844Y are available in a thermally enhanced TDFN package with an exposed pad. Connect the exposed pad to a large copper ground plane to provide a thermal contact between the device and the circuit board for increased power dissipation. The exposed pad transfers heat away from the device, allowing the IC to charge the battery with maximum current, while minimizing the increase in die temperature.

**Table 3. Input Power-Supply Selection**

IN	USB	CHARGER STATE
$4.25\text{V} \leq V_{\text{IN}} \leq 7\text{V}$	$4.25\text{V} \leq V_{\text{USB}} \leq 7\text{V}$	Enabled, selects IN power supply
$4.25\text{V} \leq V_{\text{IN}} \leq 7\text{V}$	Not present	Enabled, selects IN power supply
Not present	$4.25\text{V} \leq V_{\text{USB}} \leq 7\text{V}$	Enabled, selects USB power supply
$V_{\text{IN}} \geq 7.5\text{V}$	$4.25\text{V} \leq V_{\text{USB}} \leq 7\text{V}$	Disabled
$4.25\text{V} \leq V_{\text{IN}} \leq 7\text{V}$	$V_{\text{USB}} \geq 7.5\text{V}$	Enabled

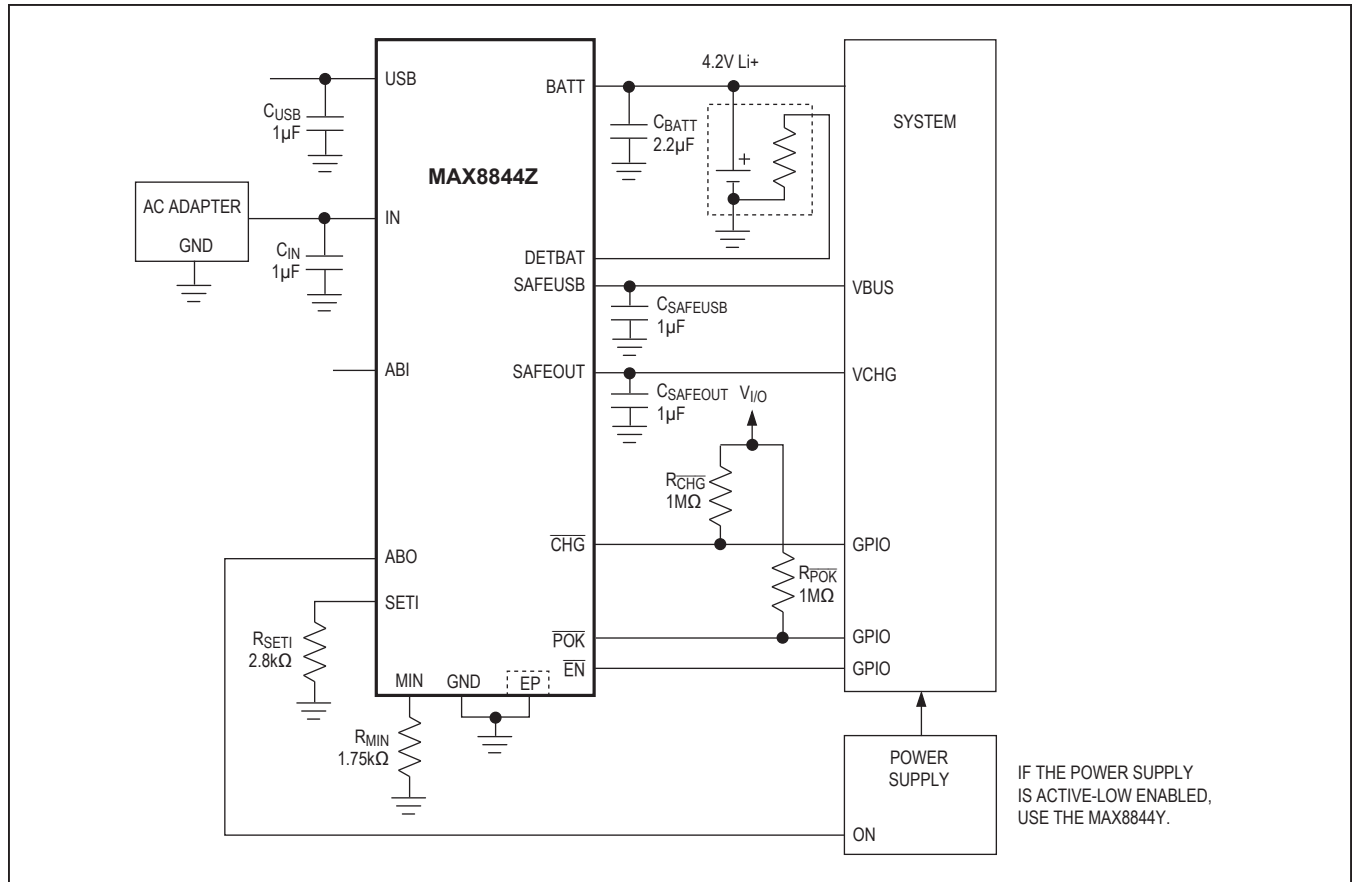

Figure 3. AC Adapter Application

### DC and USB Power Supplies

The MAX8844Z/MAX8844Y operate from well-regulated DC sources and automatically selects between both input power supply connections (Table 3). If both sources are present at the same time, highest priority is given to the IN source. The IN source is selected to insure the shortest charging time for the system since it is able to deliver the highest current. The USB fastcharge current is fixed at 380mA (MAX8844Z) and 450mA (MAX8844Y).

The full charging input voltage range for IN and USB is 4.25V to 7.5V. The device can withstand up to 28V on both inputs, IN and USB, without damage to the IC. If  $V_{IN}$  or  $V_{USB}$  is greater than 7.5V, the internal overvoltage-protection circuitry disables charging until the input falls below 7.5V. The power supplies must provide at least 4.25V at the desired peak charging current and stay below 7V when unloaded.

### Typical Application Circuits

#### AC Adapter Application

Figure 3 shows the MAX8844Z as a Li+ battery charger with an AC adapter. The MAX8844Z detects the presence of an input supply and DETBAT resulting in  $\overline{POK}$  pulled low. Once  $\overline{POK}$  is pulled low the autobooting assistant drives ABO high and enables the power supplies of the system to boot up. The MAX8844Z begins charging the battery when  $\overline{EN}$  is low or unconnected. By monitoring  $\overline{CHG}$ , the system can detect the top-off threshold and terminate the charge through  $\overline{EN}$ . The MAX8844Z also provides an overvoltage protected SAFEOUT and SAFEUSB to the system.

#### Factory System Interface Connector Application

Figure 4 shows the MAX8844Z as an autoboot assistant with the factory system interface connector. The MAX8844Z detects the ABI input even though there is no input voltage available and drives ABO high to turn on

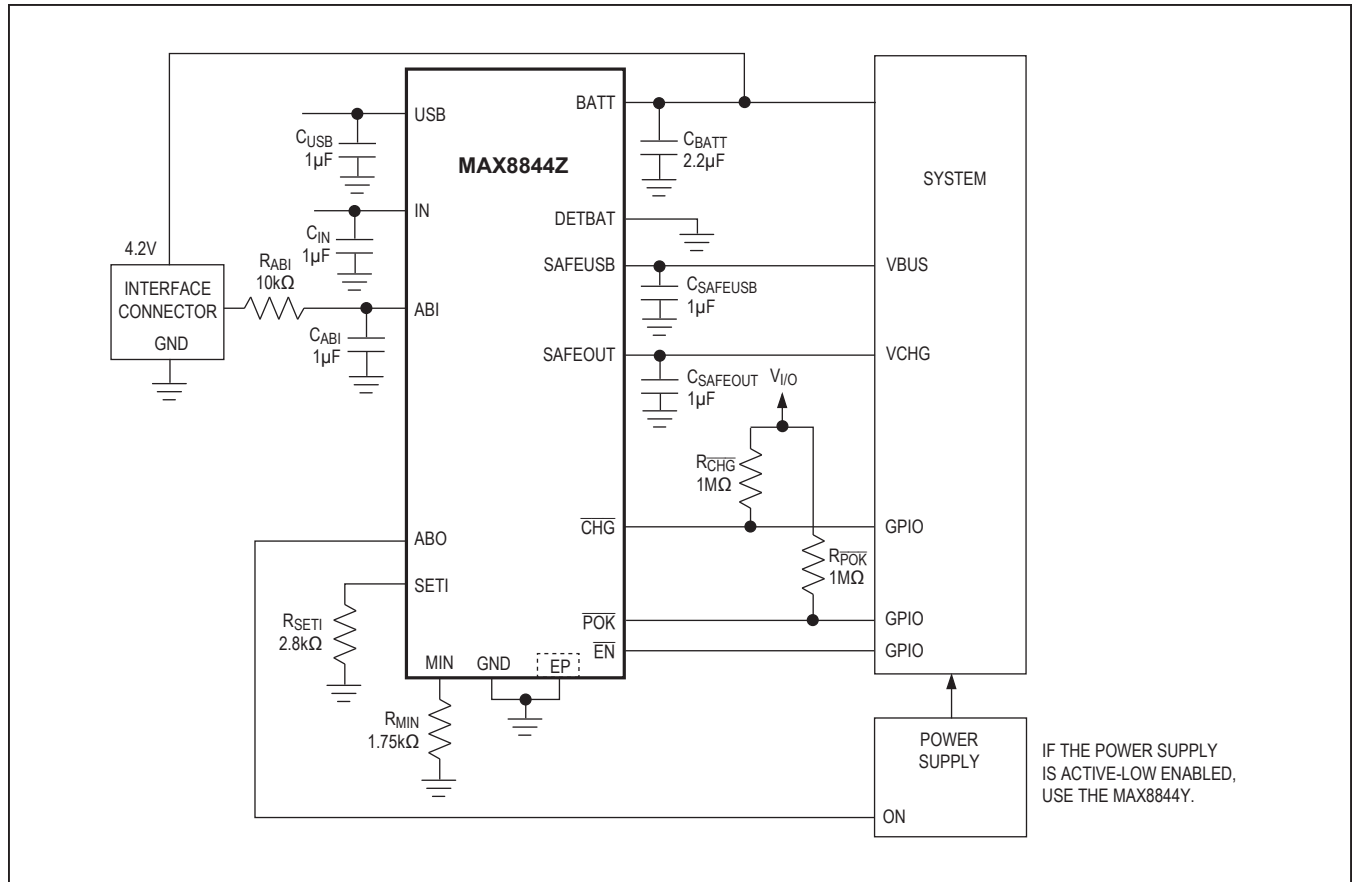

Figure 4. Factory System Interface Connector Application

power supplies to boot up the system. The configuration in Figure 4 is used for system development, testing, and calibrations in production or design stage.

**USB-Powered Li+ Charger**

The universal serial bus (USB) provides a high-speed serial communication port as well as power for the remote device. The MAX8844Z can be configured to charge a battery at the highest current possible from the host port. Figure 5 shows the MAX8844Z as a USB battery charger with the default charging current as 380mA. The MAX8844Z also provides an overvoltage protected SAFEUSB to the system.

**USB Connector and AC Adapter**

Figure 6 shows the MAX8844Z as a Li+ battery charger with an AC adapter and USB connector. The MAX8844Z detects the presence of input supplies and DETBET resulting in  $\overline{POK}$  pulled low. Once  $\overline{POK}$  is pulled low the

autobooting assistant drives ABO high and enables the power supplies of the system to boot up. The MAX8844Z begins charging the battery from IN source when  $\overline{EN}$  is low or open. By monitoring CHG, the system can detect the top-off threshold and terminate the charge through the  $\overline{EN}$  pin. The MAX8844Z provides overvoltage protected SAFEOUT and SAFEUSB to the system.

**Recommended PCB Layout and Routing**

Place all bypass capacitors for IN, USB, BATT, SAFEOUT, and SAFEUSB as close to the device as possible. Connect the battery to BATT as close as possible to the device to provide accurate battery voltage sensing. Provide a large copper ground plane to allow the exposed pad to sink heat away from the device. Make all high-current traces short and wide to minimize voltage drops. A sample layout is available in the MAX8844Z evaluation kit to speed designs.

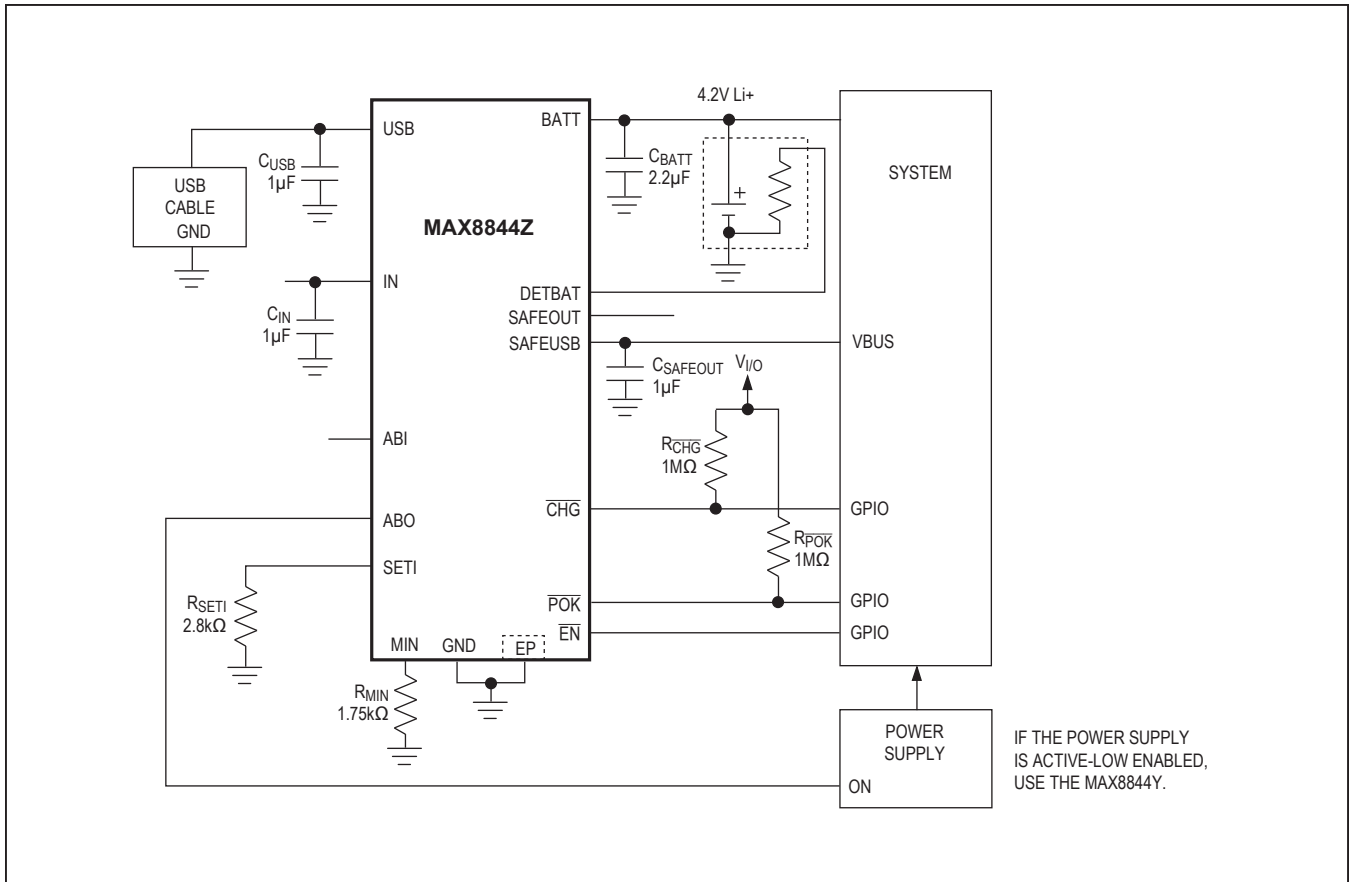

Figure 5. USB Battery Charger

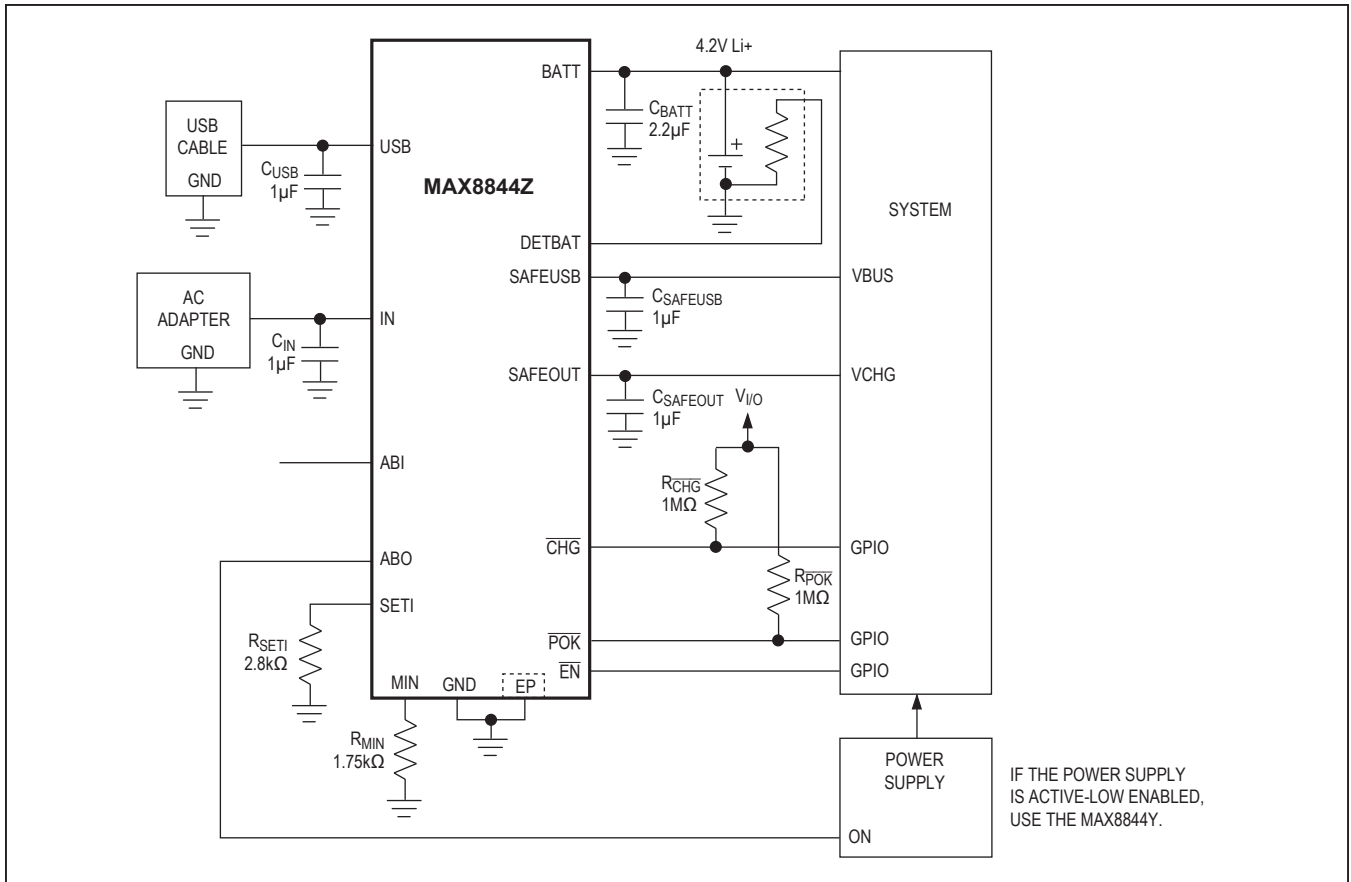

Figure 6. USB Connector and AC Adapter Application

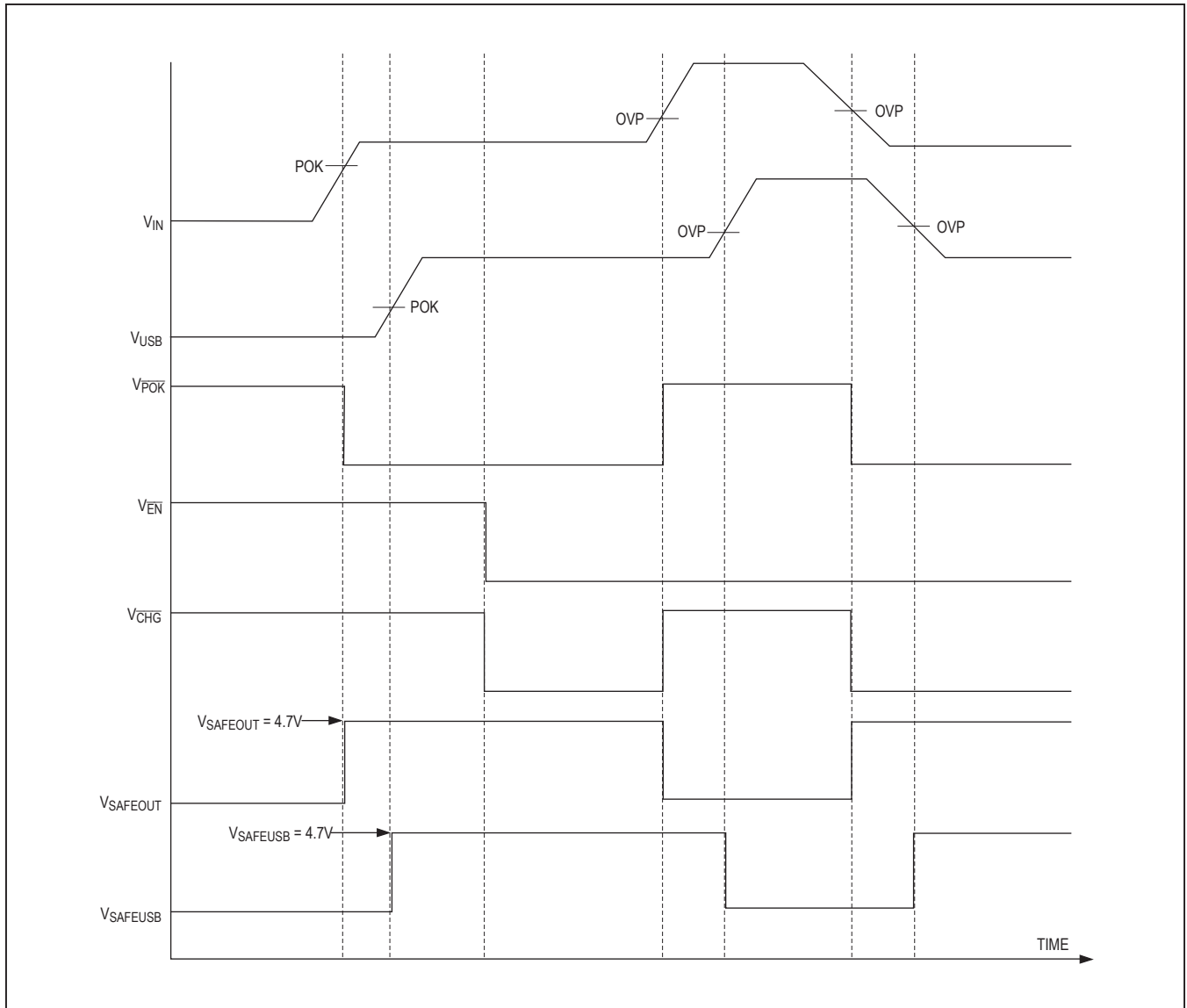
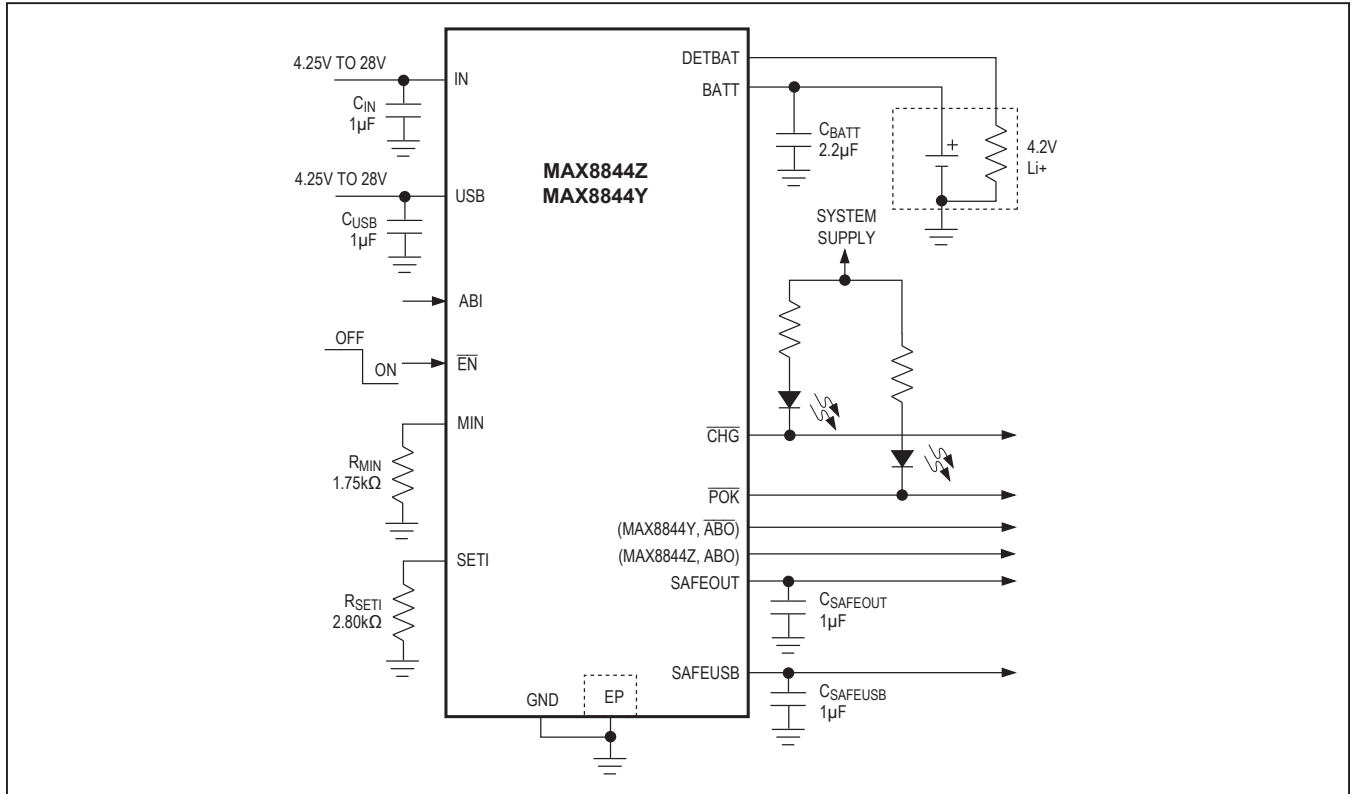

Figure 7. Timing Diagram

Typical Operating Circuit



Chip Information

PROCESS: BiCMOS

Package Information

For the latest package outline information and land patterns (footprints), go to [www.maximintegrated.com/packages](http://www.maximintegrated.com/packages). Note that a "+", "#", or "-" in the package code indicates RoHS status only. Package drawings may show a different suffix character, but the drawing pertains to the package regardless of RoHS status.

PACKAGE TYPE	PACKAGE CODE	DOCUMENT NO.
14 TDFN-EP (3mm x 3mm)	T1433-2	<a href="#">21-0137</a>

Pin Configuration

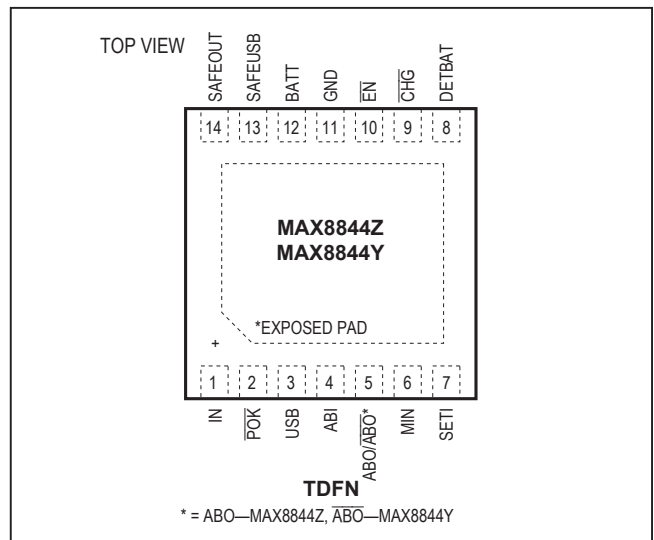

For pricing, delivery, and ordering information, please contact Maxim Direct at 1-888-629-4642, or visit Maxim Integrated's website at [www.maximintegrated.com](http://www.maximintegrated.com).

Maxim Integrated cannot assume responsibility for use of any circuitry other than circuitry entirely embodied in a Maxim Integrated product. No circuit patent licenses are implied. Maxim Integrated reserves the right to change the circuitry and specifications without notice at any time. The parametric values (min and max limits) shown in the Electrical Characteristics table are guaranteed. Other parametric values quoted in this data sheet are provided for guidance.

## Looking for pricing, stock, or lifecycle information?

Click below to explore more details on WIN SOURCE:

- ⊖ [View MAX8844YETD+T on WIN SOURCE](#)
- ⊖ [Maxim Integrated Information](#)

## Optimize Your Supply Chain with WIN SOURCE Solutions

- ✓ Global Sourcing Solution
- ✓ Obsolete Management
- ✓ Cost Control Management
- ✓ Shortage Management
- ✓ Alternative Solution
- ✓ Excess Inventory Management