



**THE DATASHEET OF
MAX9249GCM/V+T**





Gigabit Multimedia Serial Link Serializer with LVDS System Interface

MAX9249

General Description

The MAX9249 serializer with LVDS system interface utilizes Maxim's Gigabit multimedia serial link (GMSL) technology. The MAX9249 serializer pairs with any GMSL deserializer to form a complete digital serial link for joint transmission of high-speed video, audio, and control data.

The MAX9249 allows a maximum serial payload data rate of 2.5Gbps for a 15m shielded twisted-pair (STP) cable. The serializer operates up to a maximum clock rate of 104MHz (3-channel LVDS) or 78MHz (4-channel LVDS). This serial link supports display panels from QVGA (320 x 240) to WXGA (1280 x 800) and higher with 24-bit color.

The 3-channel mode handles three lanes of LVDS data (21 bits), UART control signals, and three audio signals. The 4-channel mode handles four lanes of LVDS data (28 bits), UART control signals, three audio signals, and/or up to three auxiliary parallel inputs. The three audio inputs form a standard I²S interface, supporting sample rates from 8kHz to 192kHz and audio word lengths of 4 to 32 bits. The embedded control channel forms a full-duplex, differential, 100kbps to 1Mbps UART link between the serializer and deserializer. The electronic control unit (ECU), or microcontroller (μ C), can be located on the MAX9249 side of the link (typical for video display), on the deserializer side of the link (typical for image sensing), or on both sides. In addition, the control channel enables ECU/ μ C control of peripherals on the remote side, such as backlight control, grayscale Gamma correction, camera module, and touch screen. Base-mode communication with peripherals uses either I²C or the GMSL UART format. A bypass mode enables full-duplex communication using custom UART formats.

The MAX9249 serializer driver preemphasis, along with the channel equalizer on the GMSL deserializer, extends the link length and enhances the link reliability. Spread spectrum is available on the MAX9249 to reduce EMI on the serial link and the parallel output of the GMSL deserializer. The serial output complies with ISO 10605 and IEC 61000-4-2 ESD protection standards.

The core supply for the MAX9249 is 1.8V. The I/O supply ranges from 1.8V to 3.3V. The MAX9249 is available in a 48-pin TQFP package (7mm x 7mm) with an exposed pad. Electrical performance is guaranteed over the -40°C to +105°C automotive temperature range.

Features

- ◆ Pairs with Any GMSL Deserializer
- ◆ 2.5Gbps Payload Rate AC-Coupled Serial Link with 8B/10B Line Coding
- ◆ Supports Up to WXGA (1280 x 800) with 24-Bit Color
- ◆ 8.33MHz to 104MHz (3-Channel LVDS) or 6.25MHz to 78MHz (4-Channel LVDS) Input Clock
- ◆ 4-Bit to 32-Bit Word Length, 8kHz to 192kHz I²S Audio Channel Supports High-Definition Audio
- ◆ Embedded Half-/Full-Duplex Bidirectional Control Channel (100kbps to 1Mbps)
- ◆ Interrupt Supports Touch-Screen Functions for Display Panels
- ◆ Remote-End I²C Master for Peripherals
- ◆ Preemphasis Line Driver
- ◆ Programmable Spread Spectrum on the Serial Outputs for Reduced EMI
- ◆ Automatic Data-Rate Detection Allows "On-the-Fly" Data-Rate Change
- ◆ Input Clock PLL Jitter Attenuator
- ◆ Built-In PRBS Generator for BER Testing of the Serial Link
- ◆ Line-Fault Detector Detects Serial Link Shorts to Ground, Battery, or Open Link
- ◆ ISO 10605 and IEC 61000-4-2 ESD Protection
- ◆ -40°C to +105°C Operating Temperature Range
- ◆ 1.8V to 3.3V I/O, 1.8V Core, and 3.3V LVDS Supplies
- ◆ Patent Pending

Applications

High-Resolution Automotive Navigation
Rear-Seat Infotainment
Megapixel Camera Systems

Ordering Information

PART	TEMP RANGE	PIN-PACKAGE
MAX9249GCM/V+	-40°C to +105°C	48 TQFP-EP*
MAX9249GCM/V+T	-40°C to +105°C	48 TQFP-EP*

V denotes an automotive qualified part.

+ Denotes a lead(Pb)-free/RoHS-compliant package.

*EP = Exposed pad.

T = Tape and reel.



Gigabit Multimedia Serial Link Serializer with LVDS System Interface

ABSOLUTE MAXIMUM RATINGS

AVDD to AGND	-0.5V to +1.9V	IEC 61000-4-2 (R _D = 330Ω, C _S = 150pF)	
LVDSVDD to AGND.....	-0.5V to +3.9V	Contact Discharge	
DVDD to GND	-0.5V to +1.9V	(RXIN_-, RXCLKIN_) to AGND.....	±4kV
IOVDD to GND	-0.5V to +3.9V	(OUT+, OUT-) to AGND	±10kV
Any Ground to Any Ground	-0.5V to +0.5V	Air Discharge	
RXIN_-, RXCLKIN_ to AGND.....	-0.5V to +3.9V	(RXIN_-, RXCLKIN_) to AGND.....	±8kV
OUT+, OUT- to AGND	-0.5V to +1.9V	(OUT+, OUT-) to AGND	±12kV
LMN_ to AGND (15mA current limit).....	-0.5V to +3.9V	ISO 10605 (R _D = 2kΩ, C _S = 330pF)	
All Other Pins to Any Ground.....	-0.5V to (V _{IOVDD} + 0.5V)	Contact Discharge	
OUT+, OUT- Short Circuit to Ground or Supply	Continuous	(RXIN_-, RXCLKIN_) to AGND.....	±6kV
Continuous Power Dissipation (T _A = +70°C)		(OUT+, OUT-) to AGND	±10kV
48-Pin TQFP (derate 36.2mW/°C above +70°C)....	2898.6mW	Air Discharge	
ESD Protection		(RXIN_-, RXCLKIN_) to AGND.....	±20kV
Human Body Model (R _D = 1.5kΩ, C _S = 100pF)		(OUT+, OUT-) to AGND	±30kV
(RXIN_-, RXCLKIN_-, OUT+, OUT-) to AGND	±8kV	Operating Temperature Range	-40°C to +105°C
All Other Pins to GND.....	±3kV	Junction Temperature	+150°C
		Storage Temperature Range.....	-65°C to +150°C
		Lead Temperature (soldering, 10s)	+300°C
		Soldering Temperature (reflow)	+260°C

PACKAGE THERMAL CHARACTERISTICS (Note 1)

48 TQFP-EP

Junction-to-Ambient Thermal Resistance (θ_{JA}).....27.6°C/W

Junction-to-Case Thermal Resistance (θ_{JC}).....2°C/W

Note 1: Package thermal resistances were obtained using the method described in JEDEC specification JESD51-7, using a four-layer board. For detailed information on package thermal considerations, refer to www.maxim-ic.com/thermal-tutorial.

Stresses beyond those listed under "Absolute Maximum Ratings" may cause permanent damage to the device. These are stress ratings only, and functional operation of the device at these or any other conditions beyond those indicated in the operational sections of the specifications is not implied. Exposure to absolute maximum rating conditions for extended periods may affect device reliability.

DC ELECTRICAL CHARACTERISTICS

(V_{DVDD} = V_{AVDD} = 1.7V to 1.9V, V_{LVDSVDD} = 3.0V to 3.6V, V_{IOVDD} = 1.7V to 3.6V, R_L = 100Ω ±1% (differential), T_A = -40°C to +105°C, unless otherwise noted. Differential input voltage |V_{ID}| = 0.1V to 1.2V, input common-mode voltage V_{CM} = |V_{ID}|/2 to 2.4V - |V_{ID}|/2. Typical values are at V_{DVDD} = V_{AVDD} = V_{IOVDD} = 1.8V, V_{LVDSVDD} = 3.3V, T_A = +25°C.)

PARAMETER	SYMBOL	CONDITIONS	MIN	TYP	MAX	UNITS	
SINGLE-ENDED INPUTS (P_{WDN}, S_{SEN}, B_{WS}, D_{RS}, M_S, C_{DS}, A_{UTOS}, S_{D/CNTL0}, S_{CK}, W_S, C_{NTL_})							
High-Level Input Voltage	V _{IH1}	P _{WDN} , S _{SEN} , B _{WS} , D _{RS} , M _S , C _{DS} , A _{UTOS}	0.65 x V _{IOVDD}			V	
		S _{D/CNTL0} , S _{CK} , W _S , C _{NTL_}	0.7 x V _{IOVDD}				
Low-Level Input Voltage	V _{IL1}				0.35 x V _{IOVDD}	V	
Input Current	I _{IN1}	V _{IN} = 0 to V _{IOVDD}	-10		+10	μA	
Input Clamp Voltage	V _{CL}	I _{CL} = -18mA			-1.5	V	
SINGLE-ENDED OUTPUT (INT)							
High-Level Output Voltage	V _{OH1}	I _{OH} = -2mA	V _{IOVDD} - 0.2			V	
Low-Level Output Voltage	V _{OL1}	I _{OL} = 2mA			0.2	V	
Output Short-Circuit Current	I _{OS}	V _O = 0V	V _{IOVDD} = 3.0V to 3.6V	16	35	64	mA
			V _{IOVDD} = 1.7V to 1.9V	3	12	21	

Gigabit Multimedia Serial Link Serializer with LVDS System Interface

MAX9249

DC ELECTRICAL CHARACTERISTICS (continued)

($V_{DVDD} = V_{AVDD} = 1.7V$ to $1.9V$, $V_{LVDSVDD} = 3.0V$ to $3.6V$, $V_{IOVDD} = 1.7V$ to $3.6V$, $R_L = 100\Omega \pm 1\%$ (differential), $T_A = -40^\circ C$ to $+105^\circ C$, unless otherwise noted. Differential input voltage $|V_{ID}| = 0.1V$ to $1.2V$, input common-mode voltage $V_{CM} = |V_{ID}|/2$ to $2.4V - |V_{ID}|/2$. Typical values are at $V_{DVDD} = V_{AVDD} = V_{IOVDD} = 1.8V$, $V_{LVDSVDD} = 3.3V$, $T_A = +25^\circ C$.)

PARAMETER	SYMBOL	CONDITIONS	MIN	TYP	MAX	UNITS
I²C AND UART I/O, OPEN-DRAIN OUTPUT (RX/SDA, TX/SCL, LFLT)						
High-Level Input Voltage	V_{IH2}		$0.7 \times V_{IOVDD}$			V
Low-Level Input Voltage	V_{IL2}				$0.3 \times V_{IOVDD}$	V
Input Current	I_{IN2}	$V_{IN} = 0$ to V_{IOVDD} (Note 2)	-110		+5	μA
Low-Level Open-Drain Output Voltage	V_{OL2}	$I_{OL} = 3mA$	$V_{IOVDD} = 1.7V$ to $1.9V$		0.4	V
			$V_{IOVDD} = 3.0V$ to $3.6V$		0.3	
DIFFERENTIAL OUTPUT (OUT+, OUT-)						
Differential Output Voltage	V_{OD}	Preemphasis off (Figure 1)	300	400	500	mV
		3.3dB preemphasis setting, $V_{OD(P)}$ (Figure 2)	350		610	
		3.3dB deemphasis setting, $V_{OD(D)}$ (Figure 2)	240		425	
Change in V_{OD} Between Complementary Output States	ΔV_{OD}				15	mV
Output Offset Voltage ($V_{OUT+} + V_{OUT-})/2 = V_{OS}$	V_{OS}	Preemphasis off	1.1	1.4	1.56	V
Change in V_{OS} Between Complementary Output States	ΔV_{OS}				15	mV
Output Short-Circuit Current	I_{OS}	V_{OUT+} or $V_{OUT-} = 0V$	-60			mA
		V_{OUT+} or $V_{OUT-} = 1.9V$			25	
Magnitude of Differential Output Short-Circuit Current	I_{OSD}	$V_{OD} = 0V$			25	mA
Output Termination Resistance (Internal)	R_O	From $OUT+$, $OUT-$ to V_{AVDD}	45	54	63	Ω
REVERSE CONTROL-CHANNEL RECEIVER (OUT+, OUT-)						
High Switching Threshold	V_{CHR}				27	mV
Low Switching Threshold	V_{CLR}		-27			mV
LINE-FAULT DETECTION INPUT (LMN_)						
Short-to-GND Threshold	V_{TG}	Figure 3			0.3	V
Normal Thresholds	V_{TN}	Figure 3	0.57		1.07	V
Open Thresholds	V_{TO}	Figure 3	1.45		$V_{IO} + 60mV$	V
Open Input Voltage	V_{IO}	Figure 3	1.47		1.75	V
Short-to-Battery Threshold	V_{TE}	Figure 3	2.47			
LVDS INPUTS (RXIN_ _, RXCLKIN_)						
Differential Input High Threshold	V_{TH}				50	mV
Differential Input Low Threshold	V_{TL}		-50			mV

Gigabit Multimedia Serial Link Serializer with LVDS System Interface

DC ELECTRICAL CHARACTERISTICS (continued)

($V_{DVDD} = V_{AVDD} = 1.7V$ to $1.9V$, $V_{LVDSVDD} = 3.0V$ to $3.6V$, $V_{IOVDD} = 1.7V$ to $3.6V$, $R_L = 100\Omega \pm 1\%$ (differential), $T_A = -40^\circ C$ to $+105^\circ C$, unless otherwise noted. Differential input voltage $|V_{ID}| = 0.1V$ to $1.2V$, input common-mode voltage $V_{CM} = |V_{ID}|/2$ to $2.4V - |V_{ID}|/2$. Typical values are at $V_{DVDD} = V_{AVDD} = V_{IOVDD} = 1.8V$, $V_{LVDSVDD} = 3.3V$, $T_A = +25^\circ C$.)

PARAMETER	SYMBOL	CONDITIONS	MIN	TYP	MAX	UNITS
Input Differential Termination Resistance	R_{TERM}		85	110	135	Ω
Input Current	I_{IN+}, I_{IN-}	PW $\overline{D}N$ = high or low, IN+ and IN- are shorted	-25		+25	μA
Power-Off Input Current	I_{INO+}, I_{INO-}	$V_{AVDD} = V_{DVDD} = V_{IOVDD} = 0V$	-40		+40	μA
POWER SUPPLY						
Worst-Case Supply Current (Figure 4)	I_{WCS}	BWS = GND	$f_{RXCLKIN_} = 16.6MHz$	125	165	mA
			$f_{RXCLKIN_} = 33.3MHz$	135	175	
			$f_{RXCLKIN_} = 66.6MHz$	150	190	
			$f_{RXCLKIN_} = 104MHz$	175	220	
Sleep-Mode Supply Current	I_{CCS}	LVDS inputs are not driven		45	125	μA
Power-Down Supply Current	I_{CCZ}	PW $\overline{D}N$ = GND, LVDS inputs are not driven		5	80	μA

AC ELECTRICAL CHARACTERISTICS

($V_{DVDD} = V_{AVDD} = 1.7V$ to $1.9V$, $V_{IOVDD} = 1.7V$ to $3.6V$, $R_L = 100\Omega \pm 1\%$ (differential), $T_A = -40^\circ C$ to $+105^\circ C$, unless otherwise noted. Differential input voltage $|V_{ID}| = 0.15V$ to $1.2V$, input common-mode voltage $V_{CM} = |V_{ID}|/2$ to $2.4V - |V_{ID}|/2$. Typical values are at $V_{DVDD} = V_{AVDD} = V_{IOVDD} = 1.8V$, $V_{LVDSVDD} = 3.3V$, $T_A = +25^\circ C$.)

PARAMETER	SYMBOL	CONDITIONS	MIN	TYP	MAX	UNITS
CLOCK INPUT (RXCLKIN_)						
Clock Frequency	$f_{RXCLKIN_}$	BWS = GND, $V_{DRS} = V_{IOVDD}$	8.33		16.66	MHz
		BWS = GND, DRS = GND	16.66		104	
		$V_{BWS} = V_{IOVDD}$, $V_{DRS} = V_{IOVDD}$	6.25		12.5	
		$V_{BWS} = V_{IOVDD}$, DRS = GND	12.5		78	
I²C/UART PORT TIMING (Note 3)						
Output Rise Time	t_R	30% to 70%, $C_L = 10pF$ to $100pF$, $1k\Omega$ pullup to IOVDD	20		150	ns
Output Fall Time	t_F	70% to 30%, $C_L = 10pF$ to $100pF$, $1k\Omega$ pullup to IOVDD	20		150	ns
Input Setup Time	t_{SET}	I ² C only (Figure 5)	100			ns
Input Hold Time	t_{HOLD}	I ² C only (Figure 5)	0			ns
SWITCHING CHARACTERISTICS (Note 3)						
Differential Output Rise/Fall Time	t_R, t_F	20% to 80%, $V_{OD} \geq 400mV$, $R_L = 100\Omega$, serial-bit rate = 3.125Gbps (Note 3)		90	150	ps
Total Serial Output Jitter	t_{TSOJ1}	3.125Gbps PRBS signal, measured at $V_{OD} = 0V$ differential, preemphasis disabled (Figure 6)		0.25		UI
Deterministic Serial Output Jitter	t_{DSOJ2}	3.125Gbps PRBS signal		0.15		UI
CNTL_ Input Setup Time	t_{SET}	CNTL_ (Figure 7)	3			ns
CNTL_ Input Hold Time	t_{HOLD}	CNTL_ (Figure 7)	1.5			ns
RXIN_ Skew Margin	t_{RSKM}	Figure 8	0.3			UI

Gigabit Multimedia Serial Link Serializer with LVDS System Interface

MAX9249

AC ELECTRICAL CHARACTERISTICS (continued)

(VDVDD = VAVDD = 1.7V to 1.9V, VIOVDD = 1.7V to 3.6V, RL = 100Ω ±1% (differential), TA = -40°C to +105°C, unless otherwise noted. Differential input voltage |VID| = 0.15V to 1.2V, input common-mode voltage VCM = |VID|/2 to 2.4V - |VID|/2. Typical values are at VDVDD = VAVDD = VIOVDD = 1.8V, VLVDSDVDD = 3.3V, TA = +25°C.)

PARAMETER	SYMBOL	CONDITIONS		MIN	TYP	MAX	UNITS
Serializer Delay (Note 4)	tSD	Figure 9	Spread spectrum enabled			2950	Bits
			Spread spectrum disabled			390	
Link Start Time	tLOCK	Figure 10				3.5	ms
Power-Up Time	tPU	Figure 11				3.5	ms
I²S INPUT TIMING							
WS Frequency	fWS	Table 3		8		192	kHz
Sample Word Length	nWS	Table 3		4		32	Bits
SCK Frequency	fSCK	fSCK = fWS × nWS × 2		(8 × 4) × 2		(192 × 32) × 2	kHz
SCK Clock High Time (Note 3)	tHC	VSCK ≥ VIH, tSCK = 1/fSCK		0.35 × tSCK			ns
SCK Clock Low Time (Note 3)	tLC	VSCK ≤ VIL, tSCK = 1/fSCK		0.35 × tSCK			ns
SD/CNTL0, WS Setup Time	tSET	Figure 12 (Note 3)		2			ns
SD/CNTL0, WS Hold Time	tHOLD	Figure 12 (Note 3)		2			ns

Note 2: Minimum IIN due to voltage drop across the internal pullup resistor.

Note 3: Not production tested.

Note 4: Bit time = $\frac{1}{30 \times f_{RXCLKIN_}}$ (BWS = 0), = $\frac{1}{40 \times f_{RXCLKIN_}}$ (BWS = VIOVDD)

Gigabit Multimedia Serial Link Serializer with LVDS System Interface

Typical Operating Characteristics

($V_{DVDD} = V_{AVDD} = V_{IOVDD} = 1.8V$, $V_{LVDSVDD} = 3.3V$, $T_A = +25^\circ C$, unless otherwise noted.)

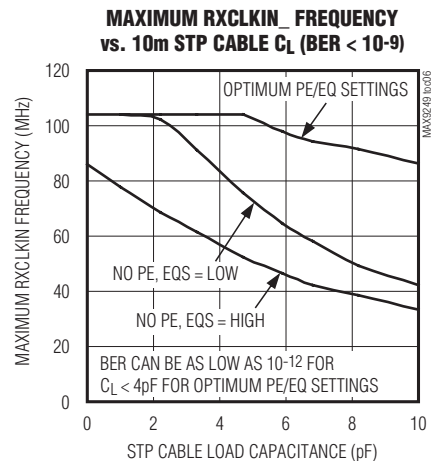
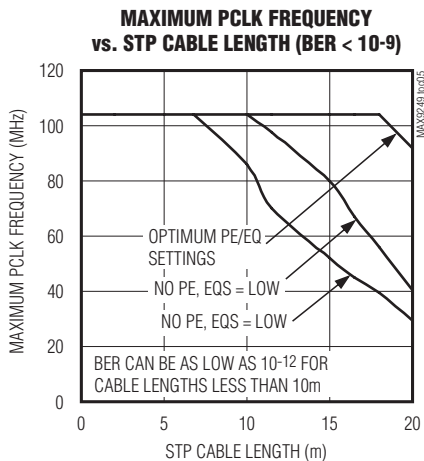
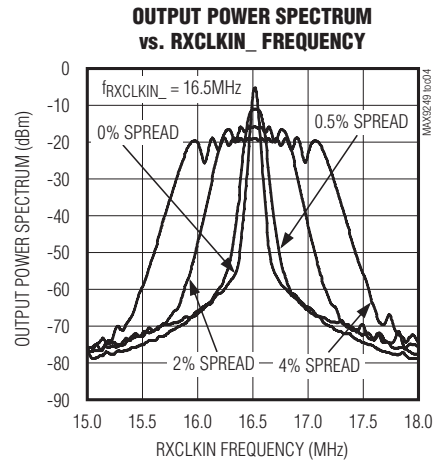
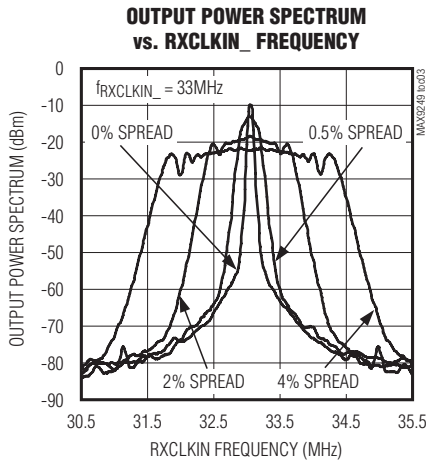
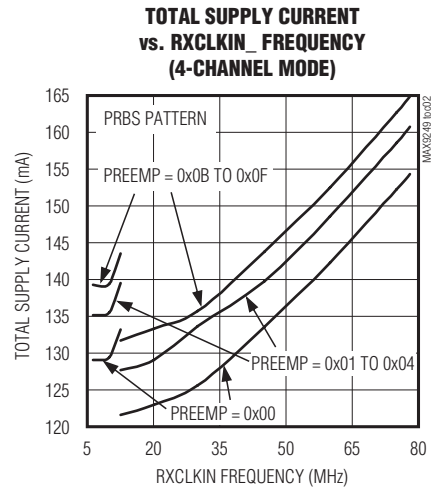
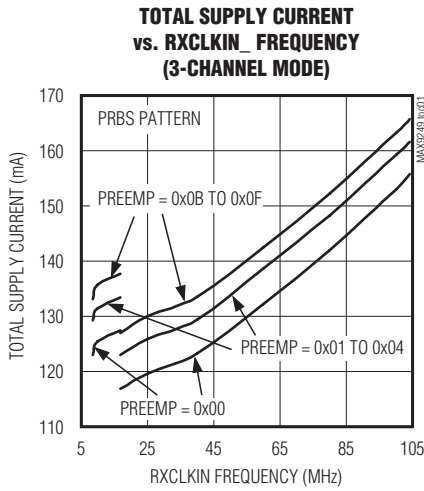

Gigabit Multimedia Serial Link Serializer with LVDS System Interface

Pin Configuration

MAX9249

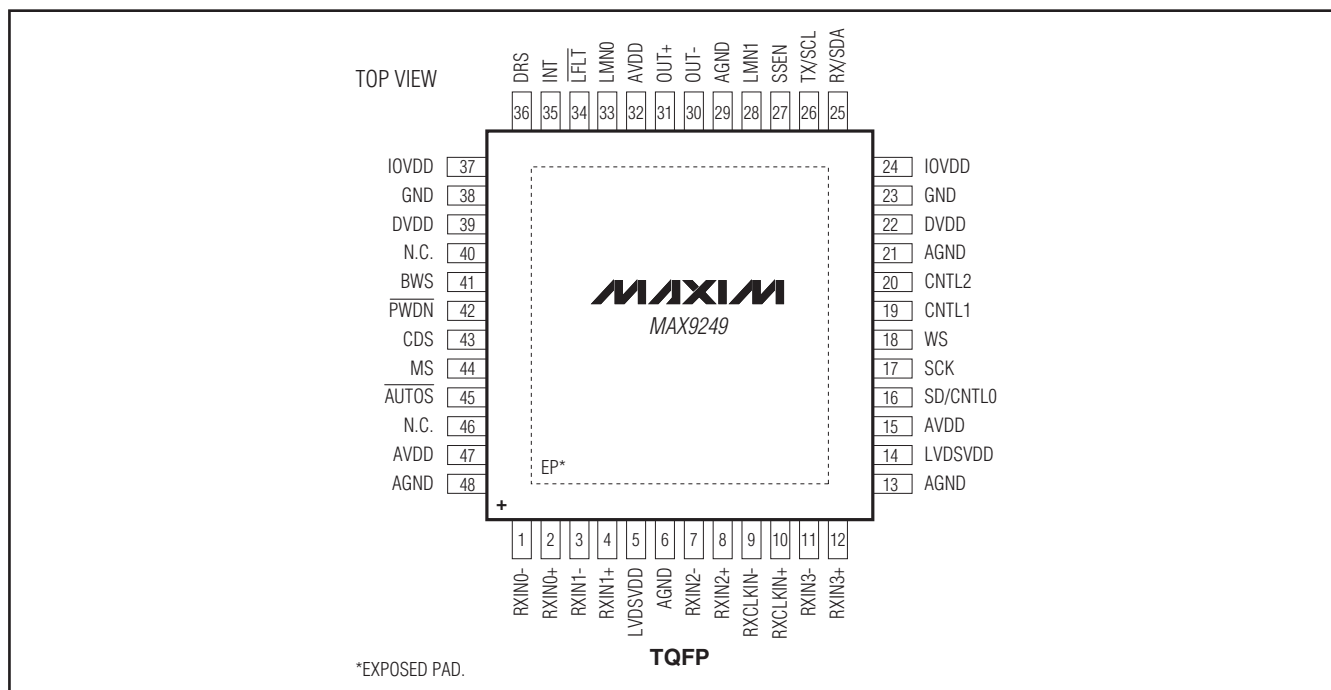

Pin Description

PIN	NAME	FUNCTION
1-4, 7, 8, 11, 12	RXIN ₋ , RXIN ₊	Differential LVDS Data Inputs. Set BWS = low (3-channel mode) to use RXIN ₀₋ to RXIN ₂₋ . Set BWS = high (4-channel mode) to use RXIN ₀₋ to RXIN ₃₋ .
5, 14	LVDSVDD	3.3V LVDS Power Supply. Bypass LVDSVDD to AGND with 0.1μF and 0.001μF capacitors as close as possible to the device with the smaller value capacitor closest to LVDSVDD.
6, 13, 21, 29, 48	AGND	Analog Ground
9, 10	RXCLKIN ₋ , RXCLKIN ₊	LVDS Input for the LVDS Clock
15, 32, 47	AVDD	1.8V Analog Power Supply. Bypass AVDD to AGND with 0.1μF and 0.001μF capacitors as close as possible to the device with the smaller value capacitor closest to AVDD.
16	SD/CNTL0	I ² S Serial-Data Input with Internal Pulldown to GND. Disable I ² S to use SD/CNTL0 as an additional input.
17	SCK	I ² S Serial-Clock Input with Internal Pulldown to GND
18	WS	I ² S Word-Select Input with Internal Pulldown to GND
19	CNTL1	Control Input 1 with Internal Pulldown to GND. Data is latched every RXCLKIN ₋ cycle (Figure 7). CNTL1 is not available in 3-channel mode. Drive BWS high (4-channel mode) to use this input. CNTL1 or RES (RES from VESA Standard Panel Specification) is mapped to DIN27 (see the <i>Reserved Bit (RES)</i> section).

Gigabit Multimedia Serial Link Serializer with LVDS System Interface

Pin Description (continued)

PIN	NAME	FUNCTION
20	CNTL2	Control Input 2 with Internal Pulldown to GND. Data is latched every RXCLKIN_ cycle (Figure 7). CNTL2 is not available in 3-channel mode. Drive BWS high (4-channel mode) to use this input. CNTL2 is mapped to DIN28.
22, 39	DVDD	1.8V Digital Power Supply. Bypass DVDD to GND with 0.1 μ F and 0.001 μ F capacitors as close as possible to the device with the smaller value capacitor closest to DVDD.
23, 38	GND	Digital and I/O Ground
24, 37	IOVDD	I/O Supply Voltage. 1.8V to 3.3V logic I/O power supply. Bypass IOVDD to GND with 0.1 μ F and 0.001 μ F capacitors as close as possible to the device with the smallest value capacitor closest to IOVDD.
25	RX/SDA	Receive/Serial Data. UART receive or I ² C serial-data input/output with internal 30k Ω pullup to IOVDD. In UART mode, RX/SDA is the Rx input of the MAX9249's UART. In I ² C mode, RX/SDA is the SDA input/output of the MAX9249's I ² C master.
26	TX/SCL	Transmit/Serial Clock. UART transmit or I ² C serial-clock output with internal 30k Ω pullup to IOVDD. In UART mode, TX/SCL is the Tx output of the MAX9249's UART. In I ² C mode, TX/SCL is the SCL output of the MAX9249's I ² C master.
27	SSEN	Spread-Spectrum Enable. Serial link spread-spectrum enable input requires external pulldown or pullup resistors. The state of SSEN latches upon power-up or when resuming from power-down mode ($\overline{\text{PWDN}}$ = low). Set SSEN = high for $\pm 0.5\%$ spread spectrum on the serial link. Set SSEN = low to use the serial link without spread spectrum.
28	LMN1	Line-Fault Monitor Input 1 (see Figure 3 for details)
30, 31	OUT-, OUT+	Differential CML Output+/- . Differential outputs of the serial link.
33	LMN0	Line-Fault Monitor Input 0 (see Figure 3 for details)
34	$\overline{\text{LFLT}}$	Line Fault. Active-low, open-drain line-fault output with a 60k Ω internal pullup resistor. $\overline{\text{LFLT}}$ = low indicates a line fault. LFLT is high impedance when $\overline{\text{PWDN}}$ = low.
35	INT	Interrupt Output to Indicate Remote Side Requests. INT = low upon power-up and when $\overline{\text{PWDN}}$ = low. A transition on the INT input of the GMSL deserializer toggles the MAX9249's INT output.
36	DRS	Data-Rate Select. Data-rate range-selection input requires external pulldown or pullup resistors. Set DRS = high for RXCLKIN_ frequencies of 8.33MHz to 16.66MHz (3-channel mode) or 6.25MHz to 12.5MHz (4-channel mode). Set DRS = low for RXCLKIN_ frequencies of 16.66MHz to 104MHz (3-channel mode) or 12.5MHz to 78MHz (4-channel mode).
40, 46	N.C.	Internally Not Connected. Connect to GND or leave unconnected.
41	BWS	Bus-Width Select. Input width selection requires external pulldown or pullup resistors. Set BWS = low for 3-channel mode. Set BWS = high for 4-channel mode.
42	$\overline{\text{PWDN}}$	Power-Down. Active-low power-down input requires external pulldown or pullup resistors.
43	CDS	Control Direction Selection. Control link direction selection input requires external pulldown or pullup resistors. Set CDS = low for μ C use on the MAX9249 side of the serial link. Set CDS = high for μ C use on the GMSL deserializer side of the serial link.
44	MS	Mode Select. Control link mode-selection input requires external pulldown or pullup resistors. Set MS = low to select base mode. Set MS = high to select the bypass mode.

Gigabit Multimedia Serial Link Serializer with LVDS System Interface

MAX9249

Pin Description (continued)

PIN	NAME	FUNCTION
45	$\overline{\text{AUTOS}}$	Autostart Setting. Active-low power-up mode-selection input requires external pulldown or pullup resistors. Set $\overline{\text{AUTOS}}$ = high to power up the device with no link active. Set $\overline{\text{AUTOS}}$ = low to have the MAX9249 power up the serial link with autorange detection (see Tables 8 and 9).
—	EP	Exposed Pad. EP internally connected to AGND. MUST externally connect EP to the AGND plane for proper thermal and electrical performance.

Functional Diagram

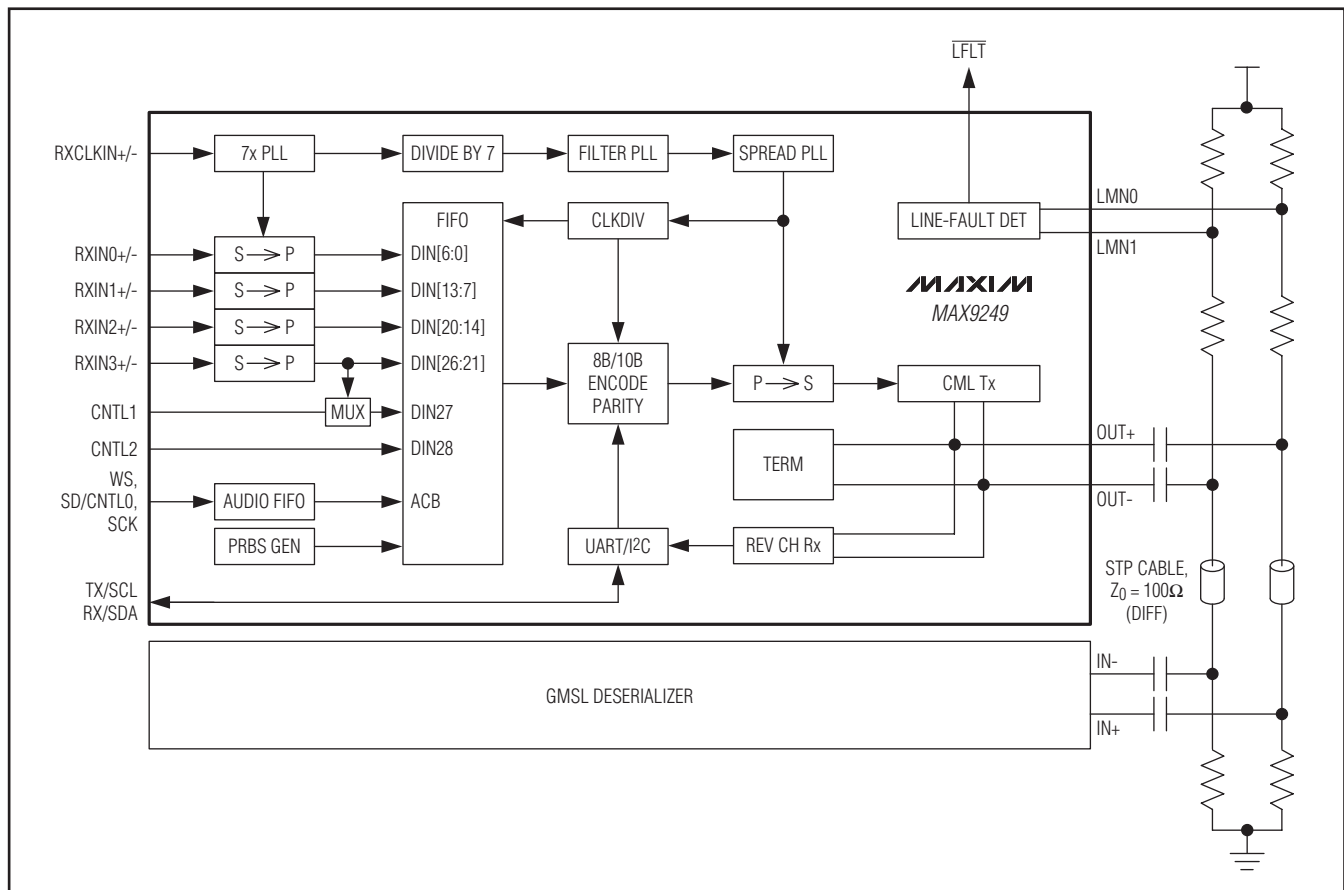

Gigabit Multimedia Serial Link Serializer with LVDS System Interface

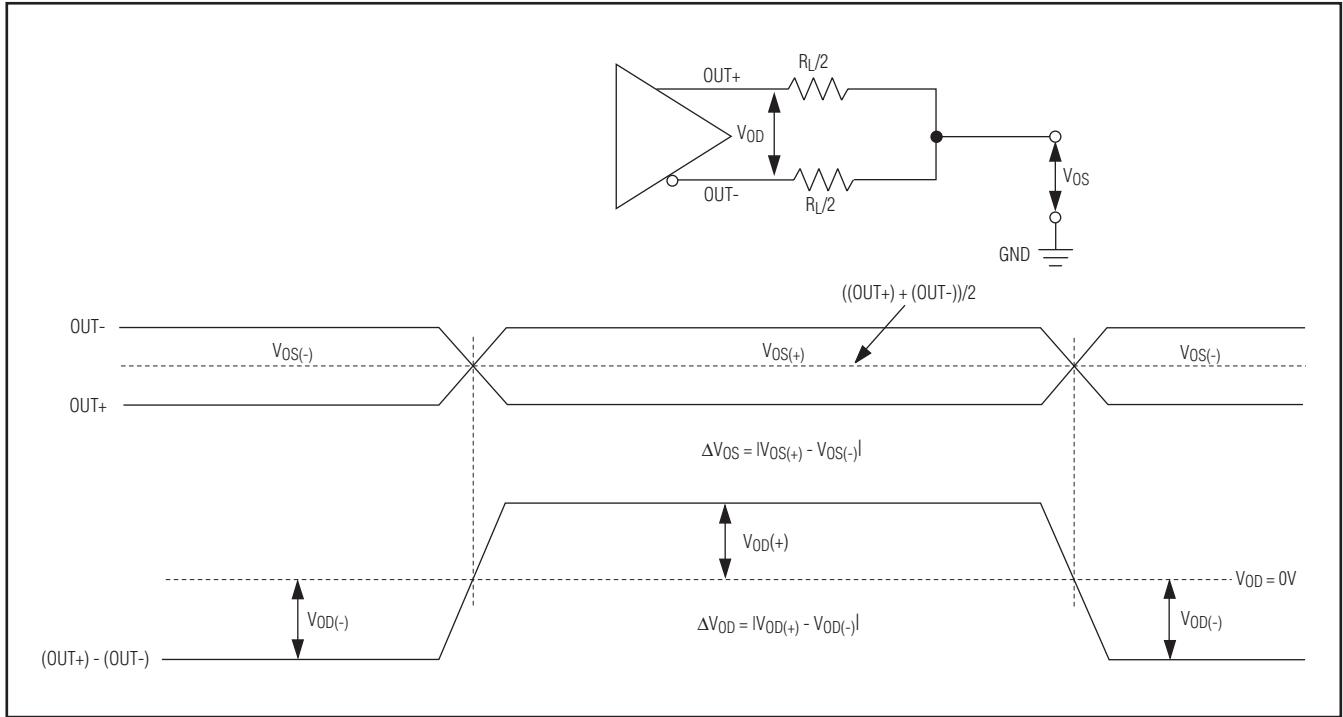

Figure 1. Serial-Output Parameters

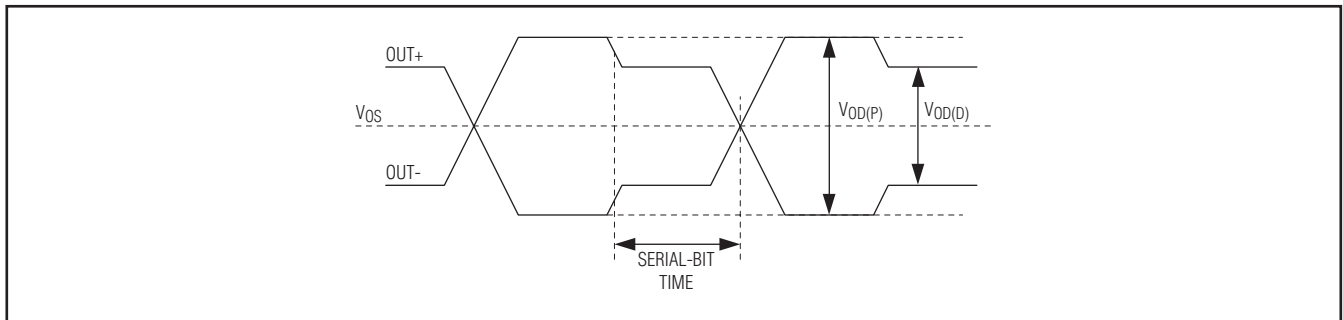

Figure 2. Output Waveforms at OUT+ and OUT-

Gigabit Multimedia Serial Link Serializer with LVDS System Interface

MAX9249

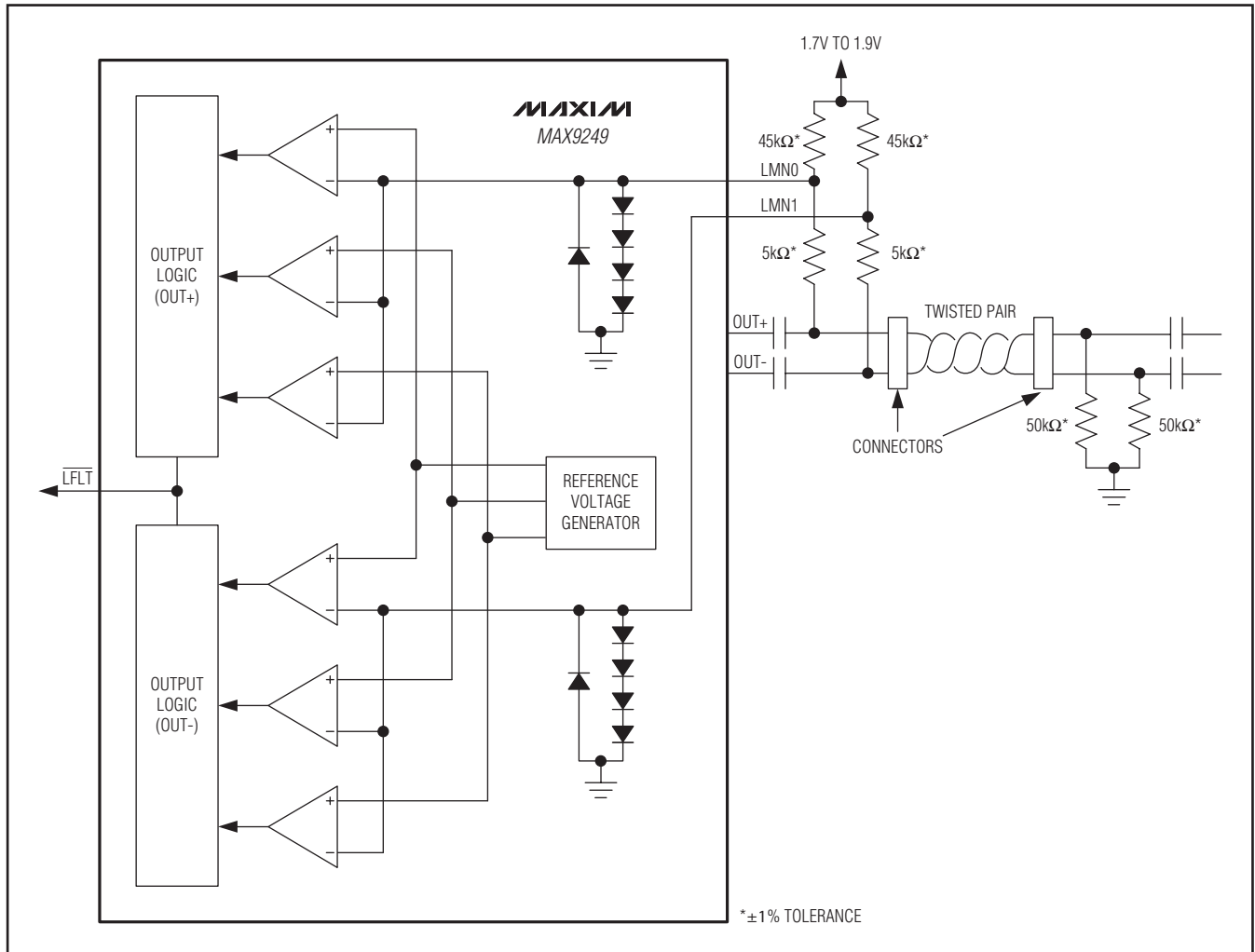

Figure 3. Line-Fault Detector Circuit

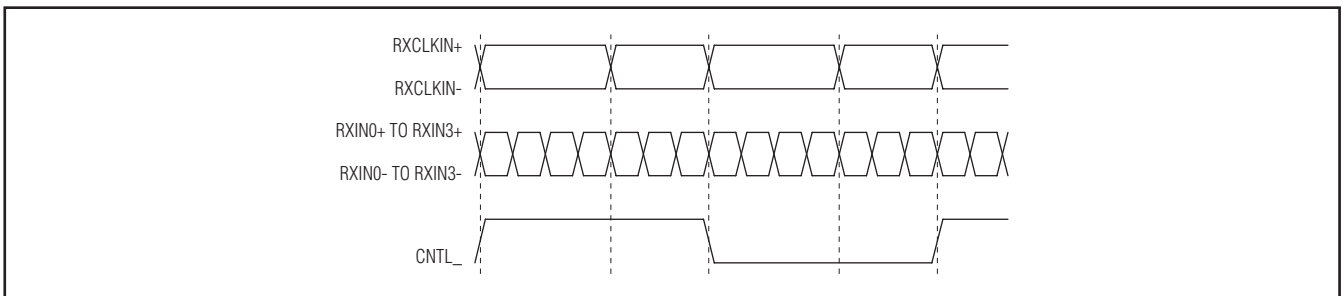

Figure 4. Worst-Case Pattern Input

Gigabit Multimedia Serial Link Serializer with LVDS System Interface

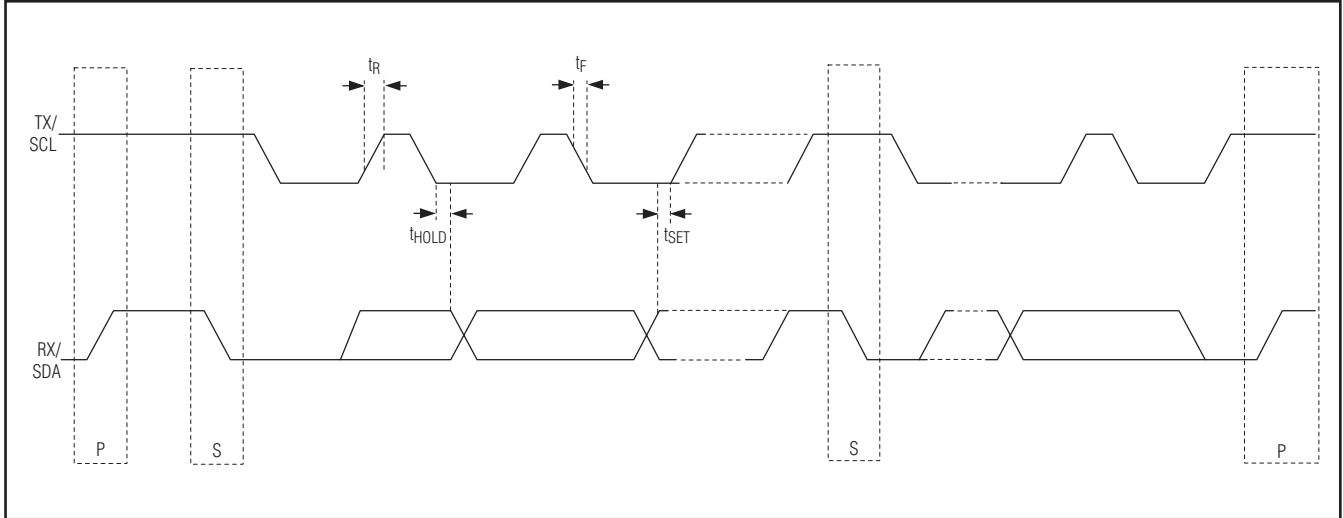

Figure 5. I²C Timing Parameters

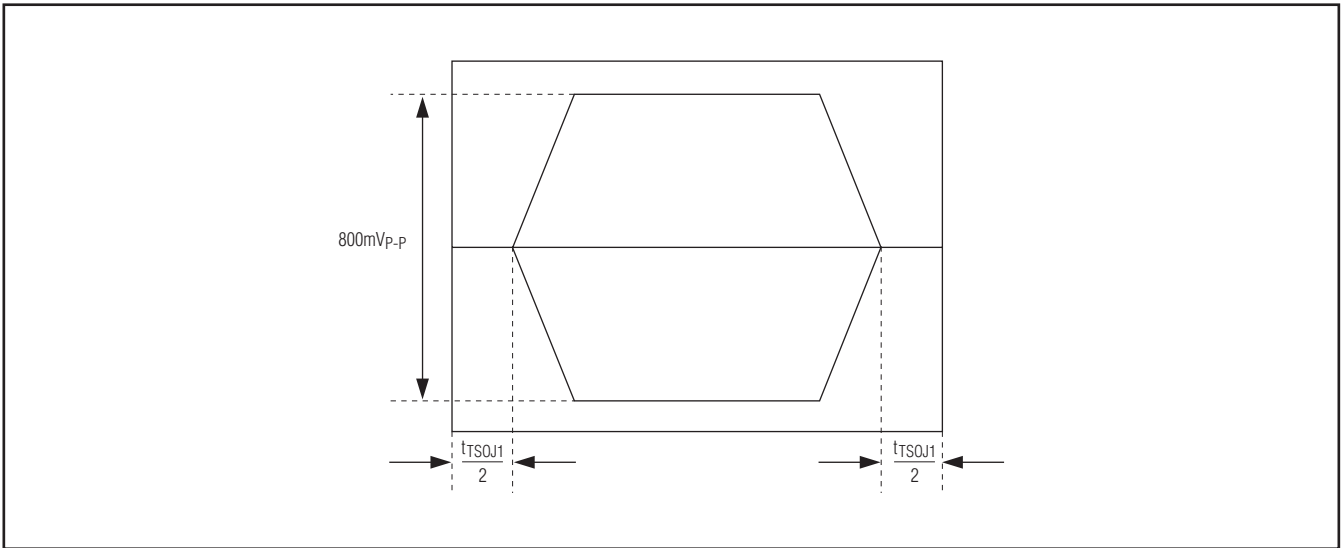

Figure 6. Differential Output Template

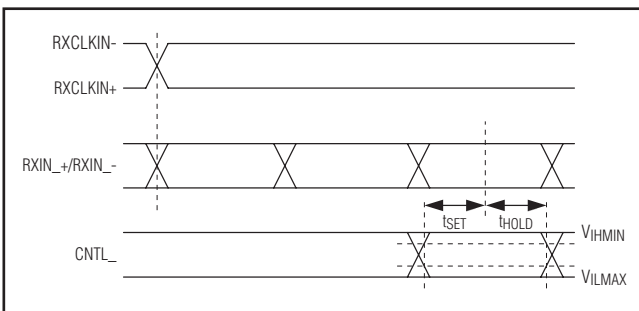

Figure 7. Input Setup-and-Hold Times

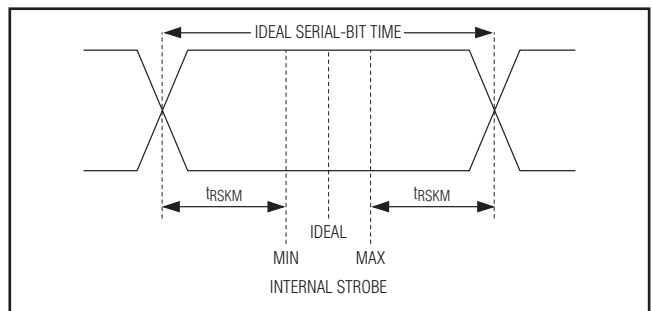

Figure 8. LVDS Receiver Input Skew Margin

Gigabit Multimedia Serial Link Serializer with LVDS System Interface

MAX9249

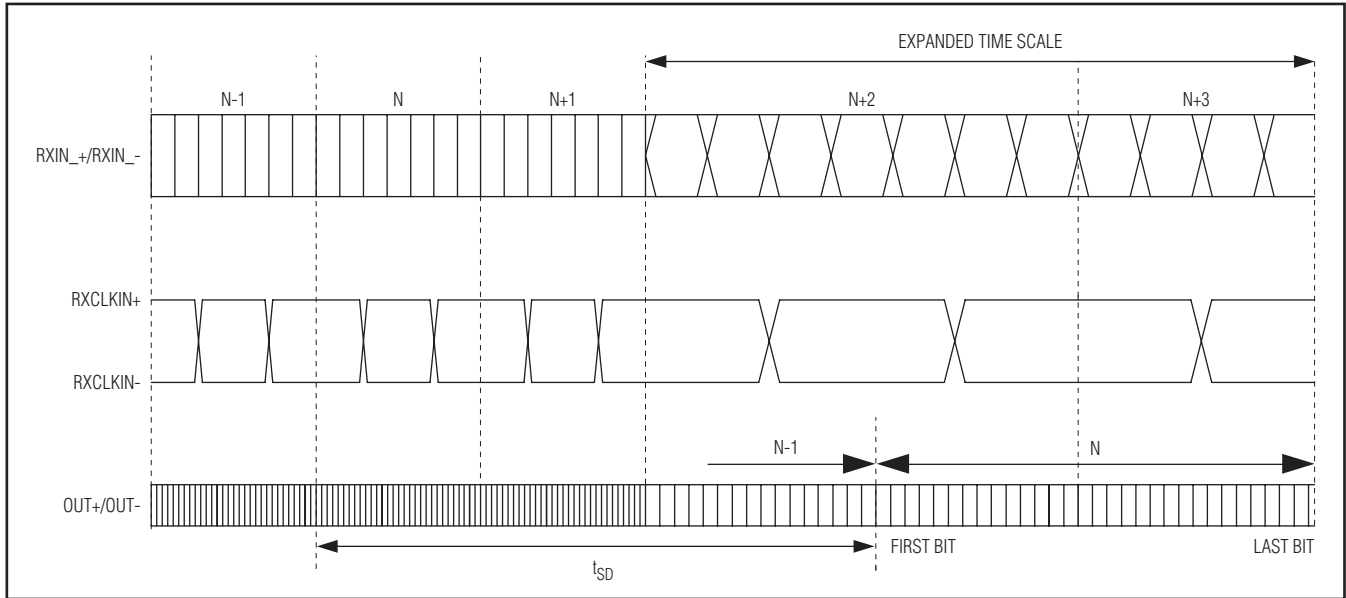

Figure 9. Serializer Delay

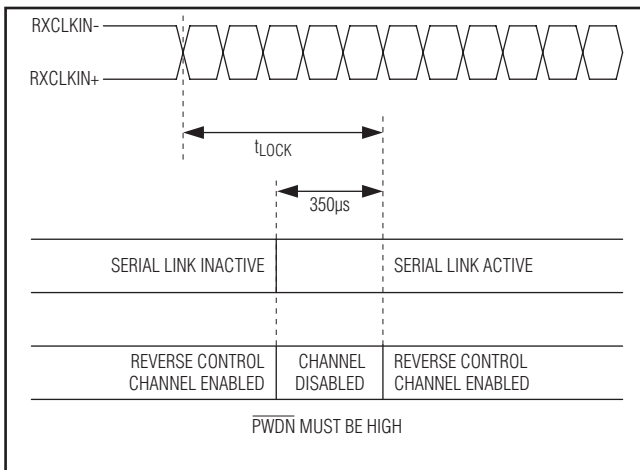

Figure 10. Link Startup Time

Gigabit Multimedia Serial Link Serializer with LVDS System Interface

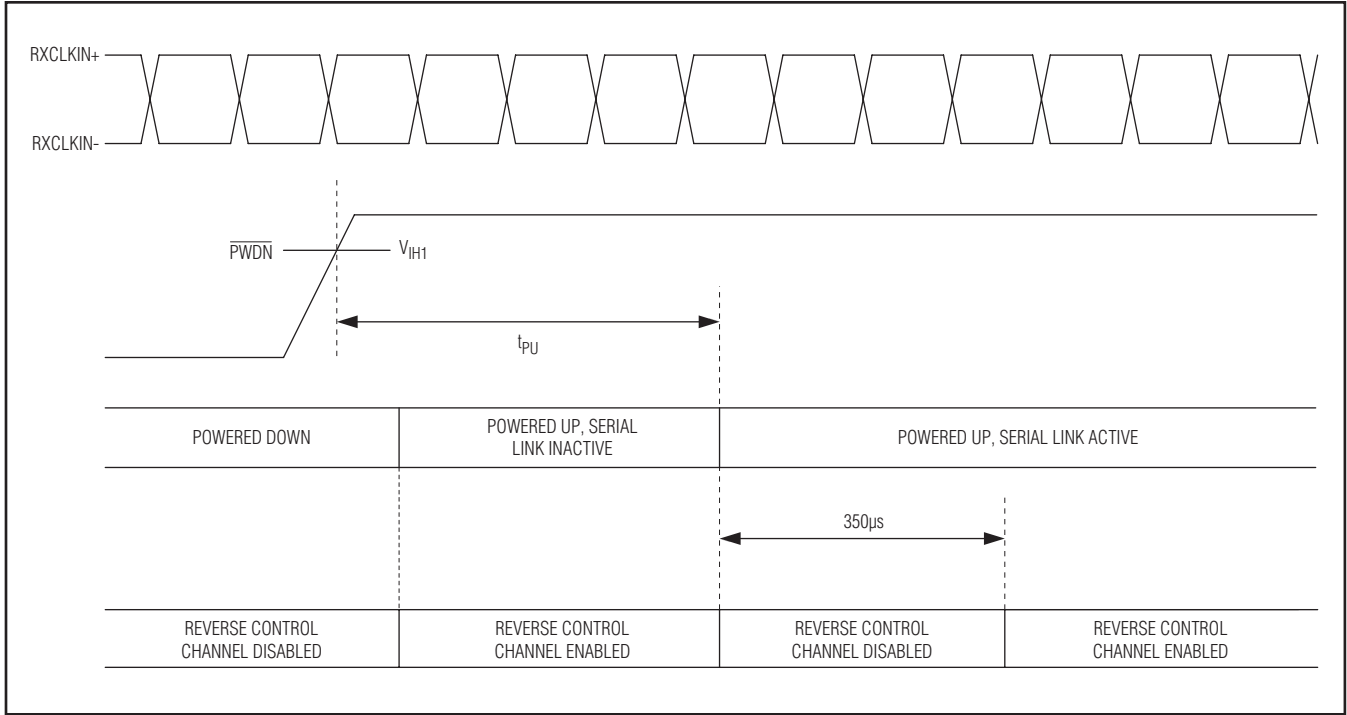

Figure 11. Power-Up Delay

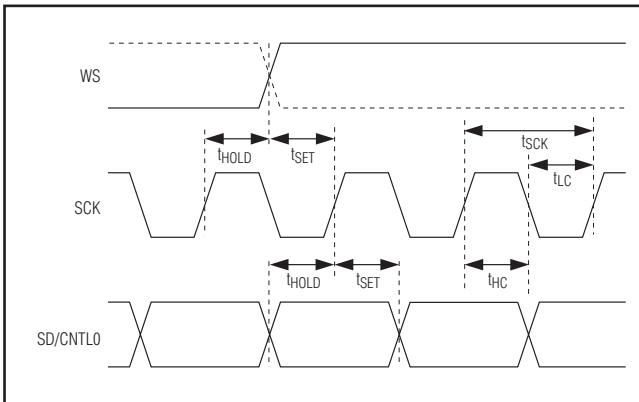

Figure 12. Input I²S Timing Parameters

Gigabit Multimedia Serial Link Serializer with LVDS System Interface

Detailed Description

The MAX9249 serializer with LVDS system interface utilizes Maxim's GMSL technology. The MAX9249 serializer pairs with any GMSL deserializer to form a complete digital serial link for joint transmission of high-speed video, audio, and control data.

The MAX9249 allows a maximum serial payload data rate of 2.5Gbps for a greater than 15m STP cable. The serializer operates up to a maximum clock of 104MHz for a 3-channel LVDS input or 78MHz for a 4-channel LVDS input. This serial link supports display panels from QVGA (320 x 240) up to WXGA (1280 x 800) with 24-bit color.

The 3-channel mode handles three lanes of LVDS data (21 bits), UART control signals, and three audio signals. The 4-channel mode handles four lanes of LVDS data (28 bits), UART control signals, three audio signals, and/or up to three auxiliary parallel inputs. The three audio inputs form a standard I²S interface, supporting sample rates from 8kHz to 192kHz and audio word lengths of 4 to 32 bits. The embedded control channel forms a full-duplex, differential, 100kbps to 1Mbps UART link between the serializer and deserializer. The ECU, or μ C, can be located on the MAX9249 side of the link (typical

for video display), on the deserializer side of the link (typical for image sensing), or on both sides. In addition, the control channel enables ECU/ μ C control of peripherals in the remote side, such as backlight control, grayscale Gamma correction, camera module, and touch screen. Base-mode communication with peripherals uses either I²C or the GMSL UART format. A bypass mode enables full-duplex communication using custom UART formats.

The MAX9249 serializer driver preemphasis, along with the channel equalizer on the GMSL deserializer, extends the link length and enhances the link reliability. Spread spectrum is available on the MAX9249 to reduce EMI on the serial link and the parallel output of the GMSL deserializer. The serial output complies with ISO 10605 and IEC 61000-4-2 ESD protection standards.

Register Mapping

The μ C configures various operating conditions of the MAX9249 and GMSL deserializer through internal registers. The default device addresses stored in the R0 and R1 registers of both the MAX9249 and GMSL deserializer are 0x80 and 0x90, respectively. Write to the R0/R1 registers in both devices to change the device address of the MAX9249 or GMSL deserializer.

Table 1. Power-Up Default Register Map (see Table 12)

REGISTER ADDRESS (HEX)	POWER-UP DEFAULT (HEX)	POWER-UP DEFAULT SETTINGS (MSB FIRST)
0x00	0x80	SERID = 1000000, serializer device address is 1000 000 RESERVED = 0
0x01	0x90	DESID = 1001000, deserializer device address is 1001 000 RESERVED = 0
0x02	0x1F, 0x3F	SS = 000 (SSEN = low), SS = 001 (SSEN = high), spread-spectrum settings depend on SSEN pin state at power-up AUDIOEN = 1, I ² S channel enabled PRNG = 11, automatically detect the pixel clock range SRNG = 11, automatically detect serial-data rate
0x03	0x00	AUTOFM = 00, calibrate spread-modulation rate only once after locking SDIV = 000000, autocalibrate sawtooth divider

Gigabit Multimedia Serial Link Serializer with LVDS System Interface

Table 1. Power-Up Default Register Map (see Table 12) (continued)

REGISTER ADDRESS (HEX)	POWER-UP DEFAULT (HEX)	POWER-UP DEFAULT SETTINGS (MSB FIRST)
0x04	0x03, 0x13, 0x83 or 0x93	SEREN = 0 ($\overline{\text{AUTOS}}$ = high), SEREN = 1 ($\overline{\text{AUTOS}}$ = low), serial link enable default depends on $\overline{\text{AUTOS}}$ pin state at power-up CLINKEN = 0, configuration link disabled PRBSEN = 0, PRBS test disabled SLEEP = 0 or 1, sleep-mode state depends on CDS and $\overline{\text{AUTOS}}$ pin state at power-up (see the <i>Link Startup Procedure</i> section) INTTYPE = 00, base mode uses I ² C REVCCEN = 1, reverse control channel active (receiving) FWDCCEN = 1, forward control channel active (sending)
0x05	0x70	I ² CMETHOD = 0, I ² C packets include register address DISFPLL = 1, filter PLL disabled CMLLVL = 11, 400mV CML signal level PREEMP = 0000, preemphasis off
0x06	0x40	RESERVED = 01000000
0x07	0x22	RESERVED = 00100010
0x08	0x0A (read only)	RESERVED = 0000 LFNEG = 10, no faults detected LFPOS = 10, no faults detected
0x0C	0x70	RESERVED = 01110000
0x0D	0x0F	SETINT = 0, interrupt output set to low RESERVED = 00 DISRES = 0, RES mapped to DIN27 SKEWADJ = 1111, no X7PLL clock skew adjustment
0x1E	0x03 (read only)	ID = 00000011, device ID is 0x03
0x1F	0x0X (read only)	RESERVED = 0000 REVISION = XXXX, revision number

VESA Standard Panel Bitmapping and Bus-Width Selection

The LVDS input has two selectable widths, 3-channel and 4-channel. The MAX9249 accepts the VESA standard panel 3- or 4-channel LVDS (Table 2). Inputs on the MAX9249 are mapped internally, according to Figures 13 and 14. In 3-channel mode, RXIN3_ and CNTL1/CNTL2 are not available. For both modes, the SD/CNTLO, SCK, and WS pins are for I²S audio. The MAX9249 accepts clock rates from 8.33MHz to 104MHz for 3-channel mode and 6.25MHz to 78MHz for 4-channel mode.

Serial Link Signaling and Data Format

The MAX9249 high-speed data serial output uses CML signaling with programmable preemphasis and AC-coupling. The GMSL deserializer uses AC-coupling and programmable channel equalization. When using both the preemphasis and equalization, the MAX9249/GMSL deserializer can operate up to 3.125Gbps over STP cable lengths to 15m or more.

The MAX9249 serializer scrambles and encodes the LVDS input data and sends the 8B/10B coded signal through the serial link. The GMSL deserializer recovers

Gigabit Multimedia Serial Link Serializer with LVDS System Interface

Table 2. Bus-Width Selection Using BWS

INPUT BITS	3-CHANNEL MODE (BWS = LOW)		4-CHANNEL MODE (BWS = HIGH)	
	VESA STANDARD PANEL MAPPING	AUXILIARY SIGNALS MAPPING	VESA STANDARD PANEL MAPPING	AUXILIARY SIGNALS MAPPING
DIN[0:5]	R[0:5]	—	R[0:5]	—
DIN[6:11]	G[0:5]	—	G[0:5]	—
DIN[12:17]	B[0:5]	—	B[0:5]	—
DIN[18:20]	HS, VS, DE	—	HS, VS, DE	—
DIN[21:22]	Not used	Not used	R6, R7	—
DIN[23:24]	Not used	Not used	G6, G7	—
DIN[25:26]	Not used	Not used	B6, B7	—
DIN27	Not used	Not used	RES*	CNTL1
DIN28	Not used	Not used	—	CNTL2
SD/CNTL0	—	SD/CNTL0	—	SD/CNTL0

*RES = Reserved (see the Reserved Bit (RES) section for details).

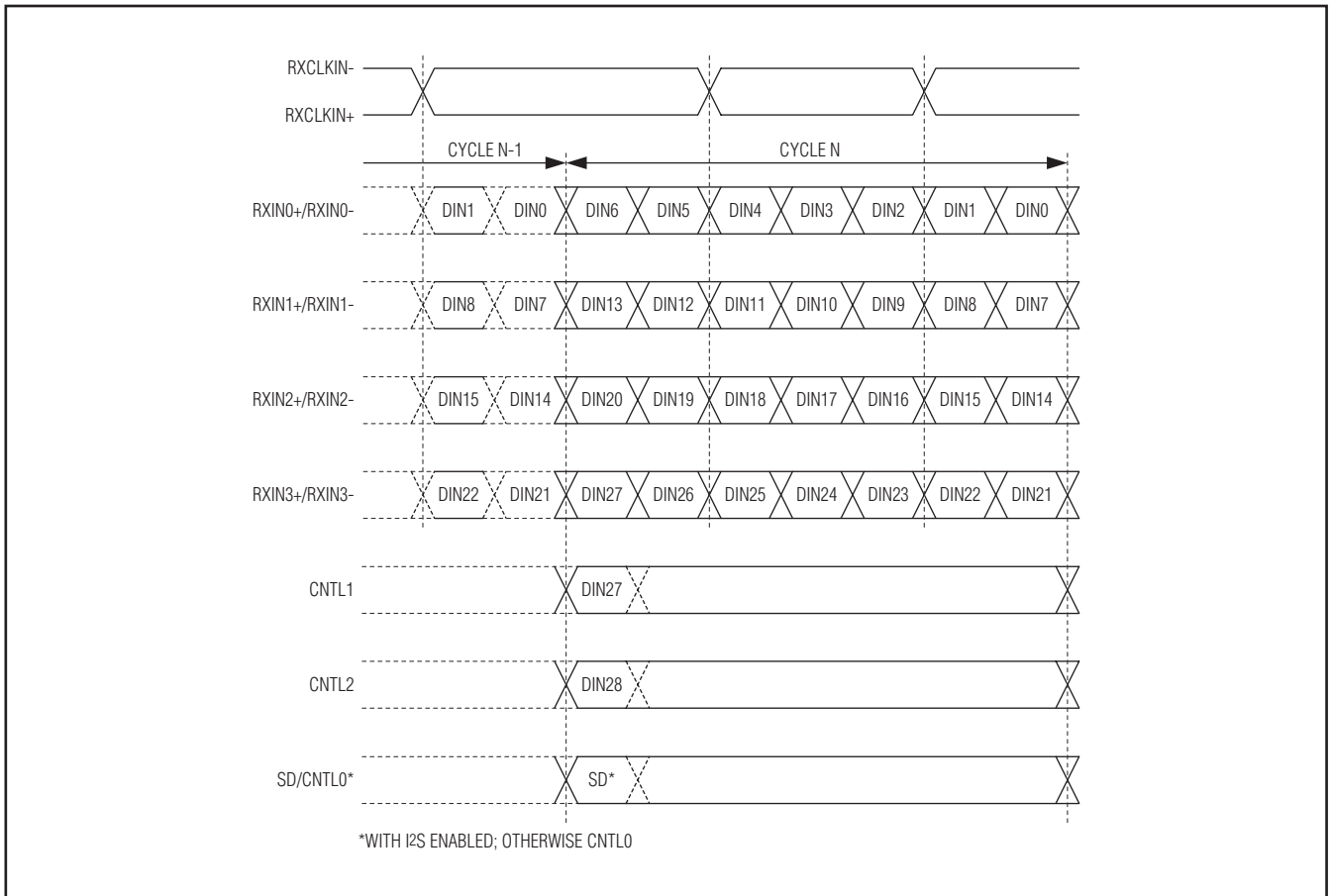

Figure 13. LVDS Input Timing

Gigabit Multimedia Serial Link Serializer with LVDS System Interface

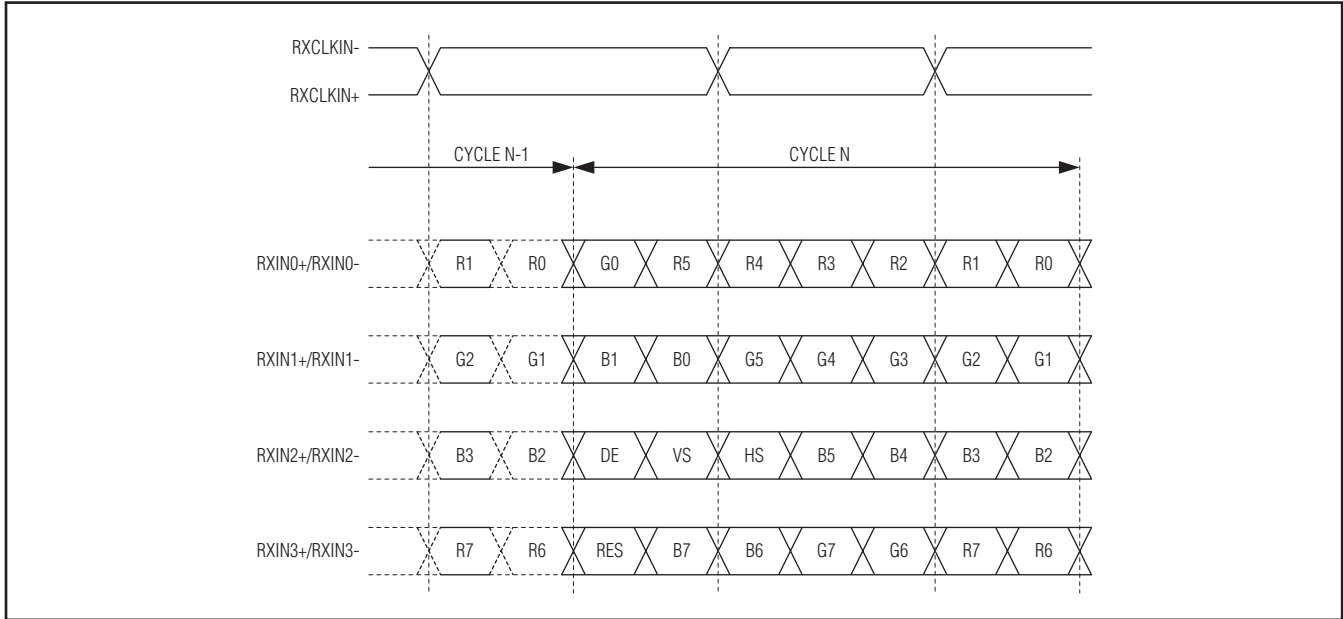

Figure 14. VESA Standard Panel Clock and Bit Assignment

the embedded serial clock and then samples, decodes, and descrambles before outputting the data. Figures 15 and 16 show the serial-data packet format before scrambling and 8B/10B coding. In 3-channel or 4-channel mode, 21 or 28 bits come from the RXIN_ LVDS inputs. Control bits can be mapped to DIN27 and DIN28 in 4-channel mode. The audio channel bit (ACB) contains an encoded audio signal derived from the three I²S inputs (SD/CNTL0, SCK, and WS). The forward control-channel (FCC) bit carries the forward control data. The last bit (PCB) is the parity bit of the previous 23 or 31 bits.

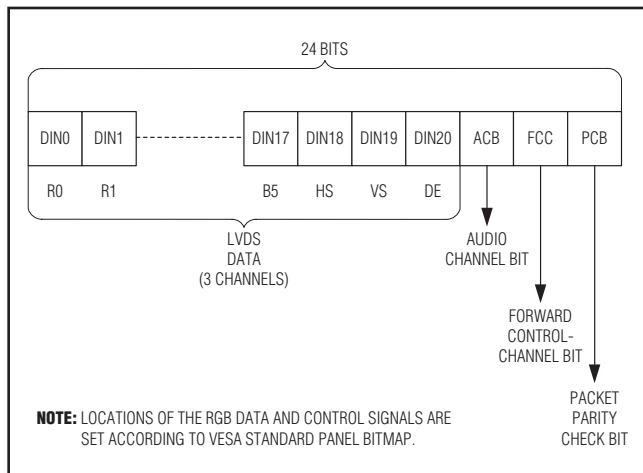

Figure 15. 3-Channel Mode Serial Link Data Format

Reserved Bit (RES)

In 4-channel mode, the MAX9249 serializes all bits of all four lanes including RES by default. Set DISRES (D4 of Register 0x0D) to 1 to map CNTL1 to DIN27 instead of RES.

Reverse Control Channel

The MAX9249 uses the reverse control channel to receive I²C/UART and interrupt signals from the GMSL deserializer in the opposite direction of the video stream. The reverse control channel and forward video data coexist on the same twisted pair forming a bidirectional link. The reverse control channel operates independently from the forward control channel. The reverse control channel is available 500µs after power-up. The MAX9249 temporarily disables the reverse control channel for 350µs after starting/stopping the forward serial link.

Data-Rate Selection

The MAX9249 uses the DRS input to set the RXCLKIN_ frequency. Set DRS high for an RXCLKIN_ frequency of 6.25MHz to 12.5MHz (4-channel mode) or 8.33MHz to 16.66MHz (3-channel mode). Set DRS low for normal operation with an RXCLKIN_ frequency of 12.5MHz to 78MHz (4-channel mode) or 16.66MHz to 104MHz (3-channel mode).

Gigabit Multimedia Serial Link Serializer with LVDS System Interface

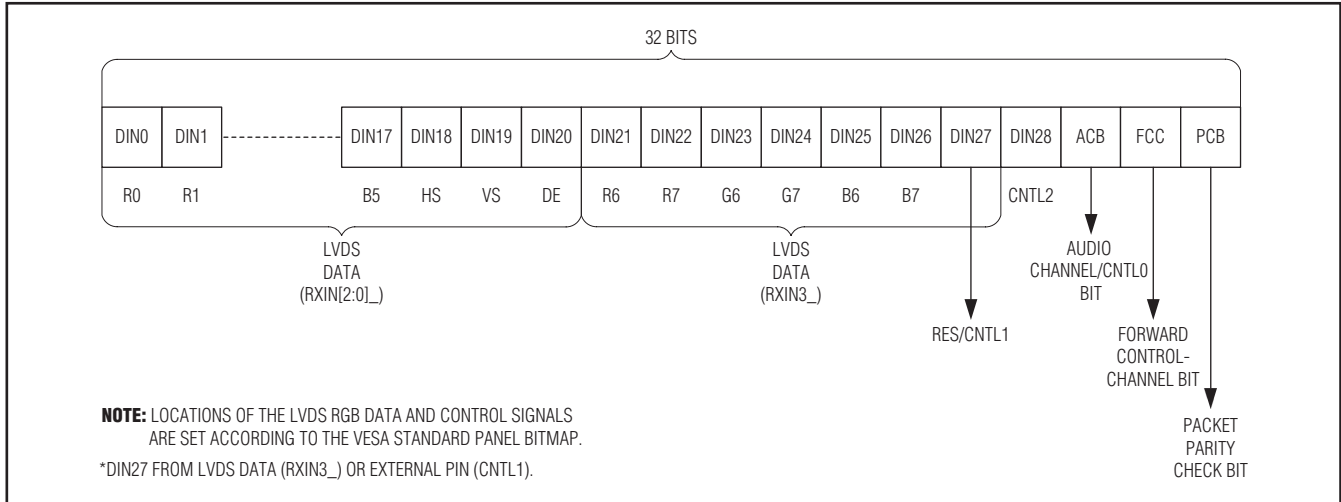

Figure 16. 4-Channel Mode Serial Link Data Format

Table 3. Maximum Audio WS Frequency (kHz) for Various RXCLKIN_ Frequencies

WORD LENGTH (BITS)	RXCLKIN_ FREQUENCY (DRS = LOW) (MHz)				RXCLKIN_ FREQUENCY (DRS = HIGH) (MHz)			
	12.5	15	16.6	> 20	6.25	7.5	8.33	> 10
8	> 192	> 192	> 192	> 192	> 192	> 192	> 192	> 192
16	> 192	> 192	> 192	> 192	> 192	> 192	> 192	> 192
18	185.5	> 192	> 192	> 192	185.5	> 192	> 192	> 192
20	174.6	> 192	> 192	> 192	174.6	> 192	> 192	> 192
24	152.2	182.7	> 192	> 192	152.2	182.7	> 192	> 192
32	123.7	148.4	164.3	> 192	123.7	148.4	164.3	> 192

Audio Channel

The I²S audio channel supports audio sampling rates from 8kHz to 192kHz and audio word lengths from 4 bits to 32 bits. The audio bit clock (SCK) does not have to be synchronized with RXCLKIN_. The MAX9249 automatically encodes audio data into a single bit stream synchronous with RXCLKIN_. The GMSL deserializer decodes the audio stream and stores audio words in a FIFO. Audio rate detection uses an internal oscillator to continuously determine the audio data rate and output the audio in I²S format. The audio channel is enabled by default. When the audio channel is disabled, the audio data on the MAX9249 and GMSL deserializer is treated as a control pin (CNTLO).

Low RXCLKIN_ frequencies limit the maximum audio sampling rate. Table 3 lists the maximum audio sampling rate for various RXCLKIN_ frequencies. Spread-

spectrum settings do not affect the I²S data rate or WS clock frequency.

Control Channel and Register Programming

The control channel is available for the μ C to send and receive control data over the serial link simultaneously with the high-speed data. Configuring the CDS pin allows the μ C to control the link from either the MAX9249 or the GMSL deserializer side to support video-display or image-sensing applications.

The control channel between the μ C and MAX9249 or GMSL deserializer runs in base mode or bypass mode according to the mode selection (MS) input of the device connected to the μ C. Base mode is a half-duplex control channel and the bypass mode is a full-duplex control channel. In base mode, the μ C is the host and can access the registers of both the MAX9249 and GMSL deserializer from either side of the link by using the GMSL

Gigabit Multimedia Serial Link Serializer with LVDS System Interface

UART protocol. The μ C can also program the peripherals on the remote side by sending the UART packets to the MAX9249 or GMSL deserializer, with the UART packets converted to I²C by the device on the remote side of the link (GMSL deserializer for LCD or MAX9249 for image-sensing applications). The μ C communicates with a UART peripheral in base mode (through INTTYPE register settings), using the half-duplex default GMSL UART protocol of the MAX9249/GMSL deserializer. The device addresses of the MAX9249 and GMSL deserializer in base mode are programmable. The default values are 0x80 for the MAX9249 and 0x90 for the GMSL deserializer.

In base mode, when the peripheral interface uses I²C (default), the MAX9249/GMSL deserializer convert packets to I²C that have device addresses different from those of the MAX9249 or GMSL deserializer. The converted I²C bit rate is the same as the original UART bit rate.

In bypass mode, the MAX9249/GMSL deserializer ignore UART commands from the μ C and the μ C communicates with the peripherals directly using its own defined UART protocol. The μ C cannot access the MAX9249/GMSL deserializer's registers in this mode. Peripherals accessed through the forward control channel using the UART interface need to handle at least one RXCLKIN_ period of jitter due to the asynchronous sampling of the UART signal by RXCLKIN_.

The MAX9249 embeds control signals going to the GMSL deserializer in the high-speed forward link. Do not send a logic-low value longer than 100 μ s in either base or bypass mode. The GMSL deserializer uses a proprietary differential line coding to send signals back towards the MAX9249. The speed of the control channel ranges from 100kbps to 1Mbps in both directions. The MAX9249/GMSL deserializer automatically detect the control channel bit rate in base mode. Packet bit rates can vary up to 3.5x from the previous bit rate (see the *Changing the Clock Frequency* section). Figure 17 shows the UART protocol for writing and reading in base mode between the μ C and the MAX9249/GMSL deserializer.

Figure 18 shows the UART data format. Even parity is used. Figures 19 and 20 detail the formats of the SYNC byte (0x79) and the ACK byte (0xC3). The μ C and the connected slave chip generate the SYNC byte and ACK byte, respectively. Events such as device wake-up and interrupt generate transitions on the control channel that should be ignored by the μ C. Data written to the MAX9249/GMSL deserializer registers does not take

effect until after the acknowledge byte is sent. This allows the μ C to verify write commands received without error, even if the result of the write command directly affects the serial link. The slave uses the SYNC byte to synchronize with the host UART data rate automatically. If the INT or MS inputs of the GMSL deserializer toggles while there is control-channel communication, the control-channel communication may be corrupted. In the event of a missed acknowledge, the μ C should assume there was an error in the packet when the slave device receives it, or that an error occurred during the response from the slave device. In base mode, the μ C must keep the UART Tx/Rx lines high for 16 bit times before starting to send a new packet.

As shown in Figure 21, the remote-side device converts the packets going to or coming from the peripherals from the UART format to the I²C format and vice versa. The remote device removes the byte number count and adds or receives the ACK between the data bytes of I²C. The I²C's data rate is the same as the UART data rate.

Interfacing Command-Byte-Only I²C Devices

The MAX9249 and GMSL deserializer UART-to-I²C conversion interfaces with devices that do not require register addresses, such as the MAX7324 GPIO expander. In this mode, the I²C master ignores the register address byte and directly reads/writes the subsequent data bytes (Figure 22). Change the communication method of the I²C master using the I2CMETHOD bit. I2CMETHOD = 1 sets command-byte-only mode, while I2CMETHOD = 0 sets normal mode where the first byte in the data stream is the register address.

Interrupt Control

The INT pin of the MAX9249 is the interrupt output and the INT pin of the GMSL deserializer is the interrupt input. The interrupt output on the MAX9249 follows the transitions at the interrupt input. This interrupt function supports remote-side functions such as touch-screen peripherals, remote power-up, or remote monitoring. Interrupts that occur during periods where the reverse control channel is disabled, such as link startup/shut-down, are automatically resent once the reverse control channel becomes available again. Bit D4 of register 0x06 in the GMSL deserializer also stores the interrupt input state. The INT output of the MAX9249 is low after power-up. In addition, the μ C can set the INT output of MAX9249 by writing to the SETINT register bit. In normal operation, the state of the interrupt output changes when the interrupt input on the GMSL deserializer toggles.

Gigabit Multimedia Serial Link Serializer with LVDS System Interface

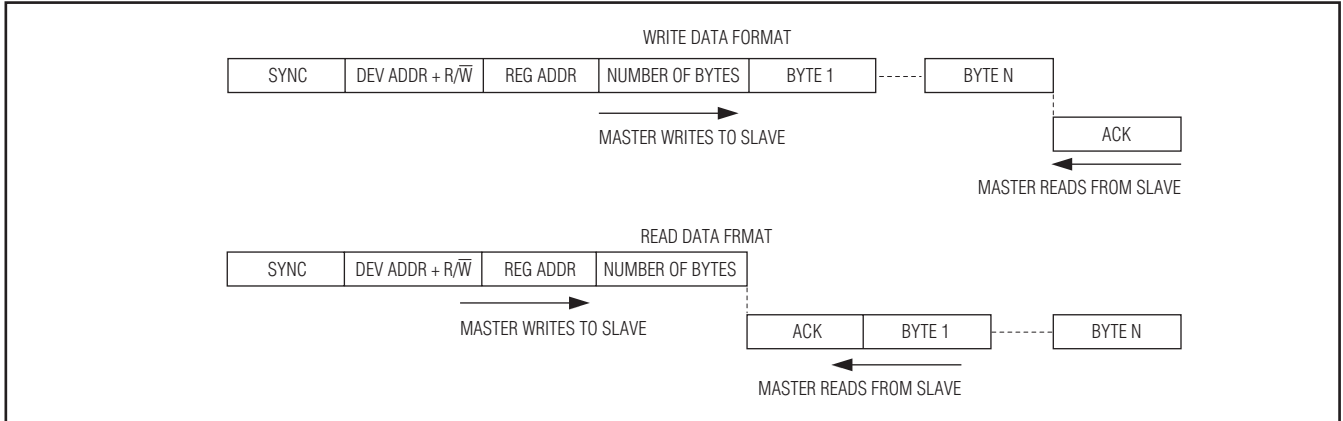

Figure 17. GMSL UART Protocol for Base Mode

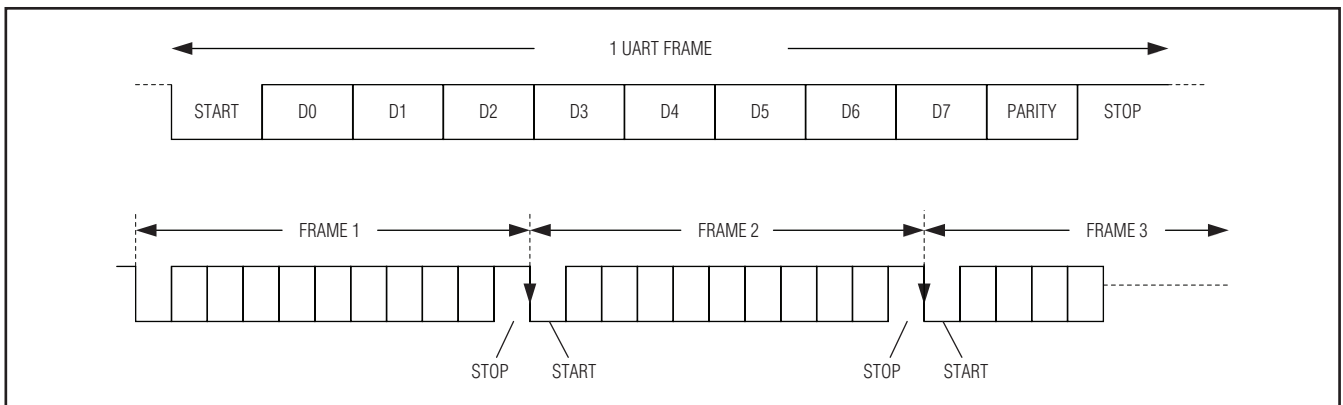

Figure 18. GMSL UART Data Format for Base Mode

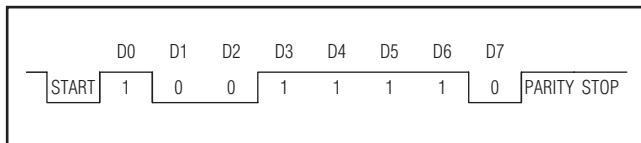

Figure 19. SYNC Byte (0x79)

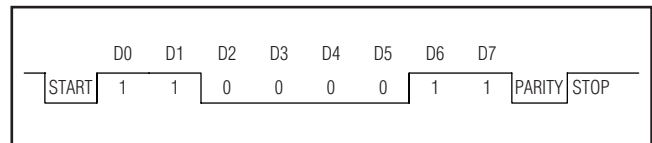

Figure 20. ACK Byte (0xC3)

Gigabit Multimedia Serial Link Serializer with LVDS System Interface

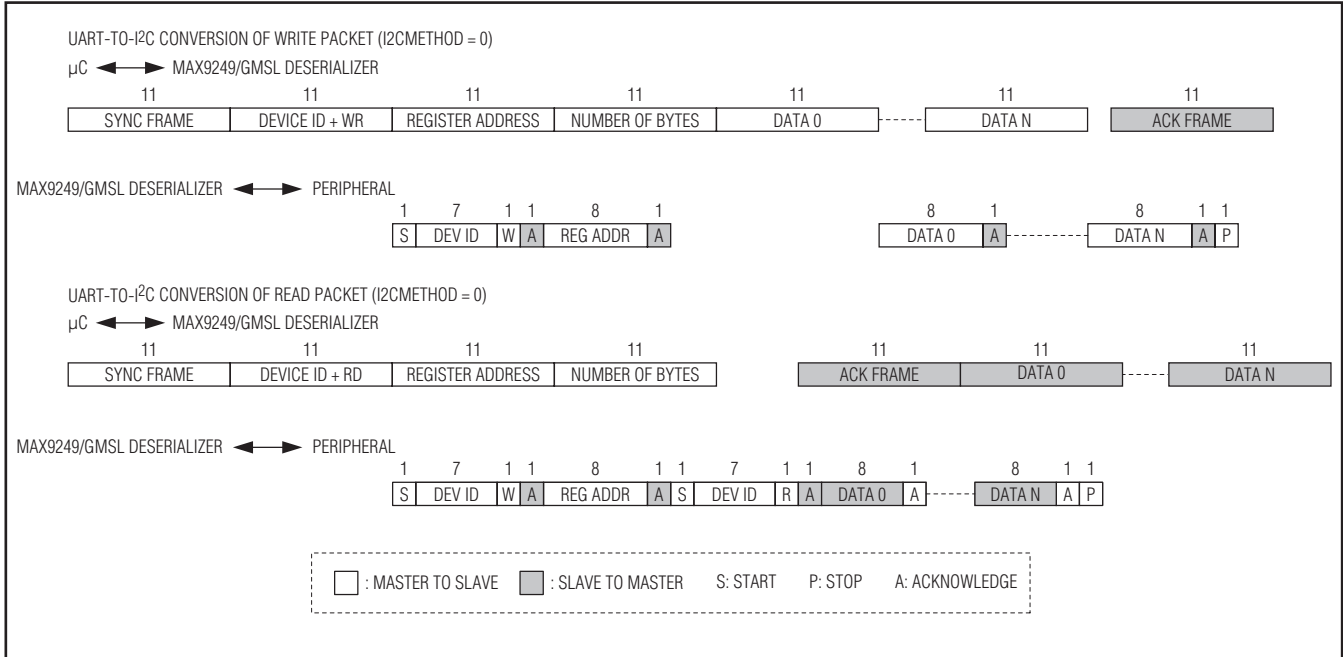

Figure 21. Format Conversion Between GMSL UART and I²C with Register Address (I2CMETHOD = 0)

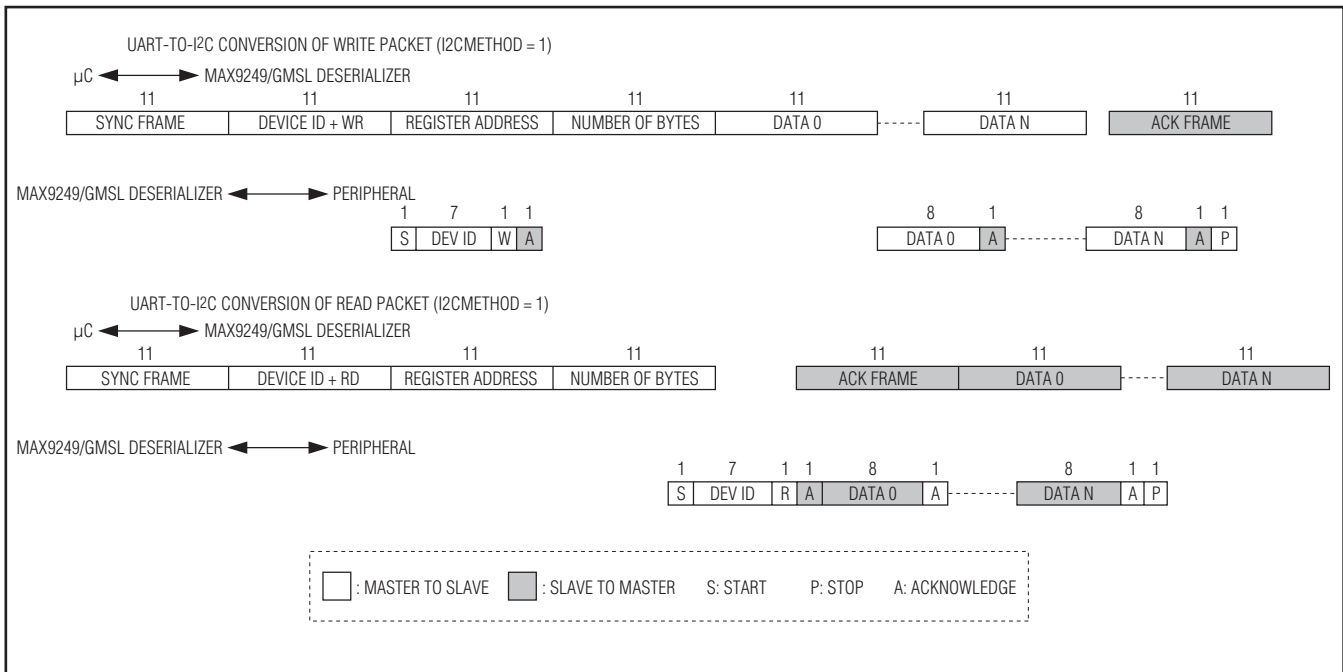

Figure 22. Format Conversion Between UART and I²C in Command-Byte-Only Mode (I2CMETHOD = 1)

Gigabit Multimedia Serial Link Serializer with LVDS System Interface

Table 4. CML Driver Strength (Default Level, CMLLVL = 11)

PREEMPHASIS LEVEL (dB)*	PREEMPHASIS SETTING (0x05, D[3:0])	I _{CML} (mA)	I _{PRE} (mA)	SINGLE-ENDED VOLTAGE SWING	
				MAX (mV)	MIN (mV)
-6.0	0100	12	4	400	200
-4.1	0011	13	3	400	250
-2.5	0010	14	2	400	300
-1.2	0001	15	1	400	350
0	0000	16	0	400	400
1.1	1000	16	1	425	375
2.2	1001	16	2	450	350
3.3	1010	16	3	475	325
4.4	1011	16	4	500	300
6.0	1100	15	5	500	250
8.0	1101	14	6	500	200
10.5	1110	13	7	500	150
14.0	1111	12	8	500	100

*Negative preemphasis levels denote deemphasis.

Table 5. Serial Output Spread

SS	SPREAD (%)
000	No spread spectrum. Power-up default when SSEN = low.
001	±0.5% spread spectrum. Power-up default when SSEN = high.
010	±1.5% spread spectrum
011	±2% spread spectrum
100	No spread spectrum
101	±1% spread spectrum
110	±3% spread spectrum
111	±4% spread spectrum

Preemphasis Driver

The serial line driver in the MAX9249 employs current-mode logic (CML) signaling. The driver can be programmed to generate a preemphasized waveform according to the cable length and characteristics. There are 13 preemphasis settings, as shown in Table 4. Negative preemphasis levels are deemphasis levels in which the swing is the same as normal, but the no-transition data is deemphasized. Program the preemphasis levels through register 0x05 D[3:0] of the MAX9249. This preemphasis function compensates the high-frequency loss of the cable and enables reliable transmission over longer link distances. Additionally, a lower power-drive mode can be entered by programming CMLLVL bits

(0x05 D[5:4]) to reduce the driver strength down to 75% (CMLLVL = 10) or 50% (CMLLVL = 01) from 100% (CMLLVL = 11, default).

Spread Spectrum

To reduce the EMI generated by the transitions on the serial link and outputs of the GMSL deserializer, both the MAX9249 and GMSL deserializer support spread spectrum. Turning on spread spectrum on the MAX9249 spreads the serial data and the GMSL deserializer outputs. Do not enable spread for both the MAX9249 and GMSL deserializer. The six selectable spread-spectrum rates at the MAX9249 serial output are ±0.5%, ±1%, ±1.5%, ±2%, ±3%, and ±4% (Table 5). Some spread-spectrum rates can only be used at lower RXCLKIN_ frequencies (Table 6). There is no RXCLKIN_ frequency limit for the 0.5% spread rate.

Set the MAX9249 SSEN input high to select 0.5% spread at power-up and SSEN input low to select no spread at power-up. The state of SSEN is latched upon power-up or when resuming from power-down mode. Whenever the MAX9249 spread spectrum is turned on or off, the serial link automatically restarts and remains unavailable while the GMSL deserializer relocks to the serial data.

Turning on spread spectrum on the MAX9249 or GMSL deserializer does not affect the audio data stream. Changes in the MAX9249 spread settings only affect the GMSL deserializer MCLK output if it is derived from RXCLKIN_ (MCLKSRC = 0).

Gigabit Multimedia Serial Link Serializer with LVDS System Interface

Table 6. Spread-Spectrum Rate Limitations

3-CHANNEL MODE RXCLKIN_ FREQUENCY (MHz)	4-CHANNEL MODE RXCLKIN_ FREQUENCY (MHz)	SERIAL LINK BIT RATE (Mbps)	AVAILABLE SPREAD RATES
< 33.3	< 25	< 1000	All rates available
33.3 to < 66.7	20 to < 50	1000 to < 2000	1.5%, 1.0%, 0.5%
≥ 66.7	≥ 50	≥ 2000	0.5%

Table 7. Modulation Coefficients and Maximum SDIV Settings

BUS-WIDTH MODE	SPREAD-SPECTRUM SETTING (%)	MODULATION COEFFICIENT (DECIMAL)	SDIV UPPER LIMIT (DECIMAL)
4-Channel	0.5	104	63
	1	104	40
	1.5	152	54
	2	204	30
	3	152	27
	4	204	15
3-Channel	0.5	80	63
	1	80	52
	1.5	112	63
	2	152	42
	3	112	37
	4	152	21

Both devices include a sawtooth divider to control the spread-modulation rate. Autodetection or manual programming of the RXCLKIN_ operation range guarantees a spread-spectrum modulation frequency within 20kHz to 40kHz. Additionally, manual configuration of the sawtooth divider (SDIV, 0x03 D[5:0]) allows the user to set a modulation frequency according to the RXCLKIN_ frequency. Always keep the modulation frequency between 20kHz to 40kHz to ensure proper operation.

Manual Programming of the Spread-Spectrum Divider

The modulation rate for the MAX9249 relates to the RXCLKIN_ frequency as follows:

$$f_M = (1 + \text{DRS}) \frac{f_{\text{RXCLKIN}_}}{\text{MOD} \times \text{SDIV}}$$

where:

f_M = Modulation frequency

DRS = DRS pin input value (0 or 1)

$f_{\text{RXCLKIN}_}$ = LVDS clock frequency

MOD = Modulation coefficient given in Table 7

SDIV = 6-bit SDIV setting, manually programmed by the μC

To program the SDIV setting, first look up the modulation coefficient according to the part number and desired bus-width and spread-spectrum settings. Solve the above equation for SDIV using the desired pixel clock and modulation frequencies. If the calculated SDIV value is larger than the maximum allowed SDIV value in Table 7, set SDIV to the maximum value.

Sleep Mode

The MAX9249/GMSL deserializer include low-power sleep mode to reduce power consumption on the device not attached to the μC (the GMSL deserializer in LCD applications and the MAX9249 in camera applications). Set the corresponding remote IC's SLEEP bit to 1 to initiate sleep mode. The MAX9249 sleeps immediately after

Gigabit Multimedia Serial Link Serializer with LVDS System Interface

Table 8. Startup Selection for Video-Display Applications (CDS = Low)

CASE	$\overline{\text{AUTOS}}$ (MAX9249)	MAX9249 POWER-UP STATE	MS (GMSL DESERIALIZER)	GMSL DESERIALIZER POWER-UP STATE	LINK STARTUP MODE
1	Low	Serialization enabled	Low	Normal (SLEEP = 0)	Both devices power up with serial link active (autostart)
2	High	Serialization disabled	High	Sleep mode (SLEEP = 1)	Serial link is disabled and the GMSL deserializer powers up in sleep mode. Set SEREN = 1 or CLINKEN = 1 in the MAX9249 to start the serial link and wake up the GMSL deserializer.
3	High	Serialization disabled	Low	Normal (SLEEP = 0)	Both devices power up in normal mode with the serial link disabled. Set SEREN = 1 or CLINKEN = 1 in the MAX9249 to start the serial link.
4	Low	Serialization enabled	High	Sleep mode (SLEEP = 1)	GMSL deserializer starts in sleep mode. Link autostarts upon MAX9249 power-up. Use this case when the GMSL deserializer powers up before the MAX9249.

setting its SLEEP = 1. The GMSL deserializer sleeps after serial link inactivity or 8ms (whichever arrives first) after setting its SLEEP = 1. See the *Link Startup Procedure* section for details on waking up the device for different μC and starting conditions.

The μC side device cannot enter into sleep mode. If an attempt is made to program the μC side device for sleep, the SLEEP bit remains 0. Use the $\overline{\text{PWDN}}$ input pin to bring the μC side device into a low-power state.

Configuration Link Mode

The MAX9249 includes a low-speed configuration link to allow control-data connection between the two devices in the absence of a valid clock input. In either display or camera applications, the configuration link can be used to program equalizer/preemphasis or other registers before establishing the video link. An internal oscillator provides RXCLKIN_ for establishing the serial configuration link between the MAX9249 and GMSL deserializer. Set CLINKEN = 1 on the MAX9249 to turn on the configuration link. The configuration link remains active as long as the video link has not been enabled. The video link overrides the configuration link and attempts to lock when SEREN = 1.

Link Startup Procedure

Table 8 lists four startup cases for video-display applications. Table 9 lists two startup cases for image-sensing applications. In either video-display or image-sensing applications, the control link is always available after the high-speed data link or the configuration link is established and the MAX9249/GMSL deserializer registers or the peripherals are ready for programming.

Video-Display Applications

For the video-display application, with a remote display unit, connect the μC to the serializer (MAX9249) and set CDS = low for both the MAX9249 and GMSL deserializer. Table 8 summarizes the four startup cases based on the settings of $\overline{\text{AUTOS}}$ and MS.

Case 1: Autostart Mode

After power-up or when $\overline{\text{PWDN}}$ transitions from low to high for both the serializer and deserializer, the serial link establishes if a stable RXCLKIN_ is present. The MAX9249 locks to RXCLKIN_ and sends the serial data to the GMSL deserializer. The GMSL deserializer then detects activity on the serial link and locks to the input serial data.

Gigabit Multimedia Serial Link Serializer with LVDS System Interface

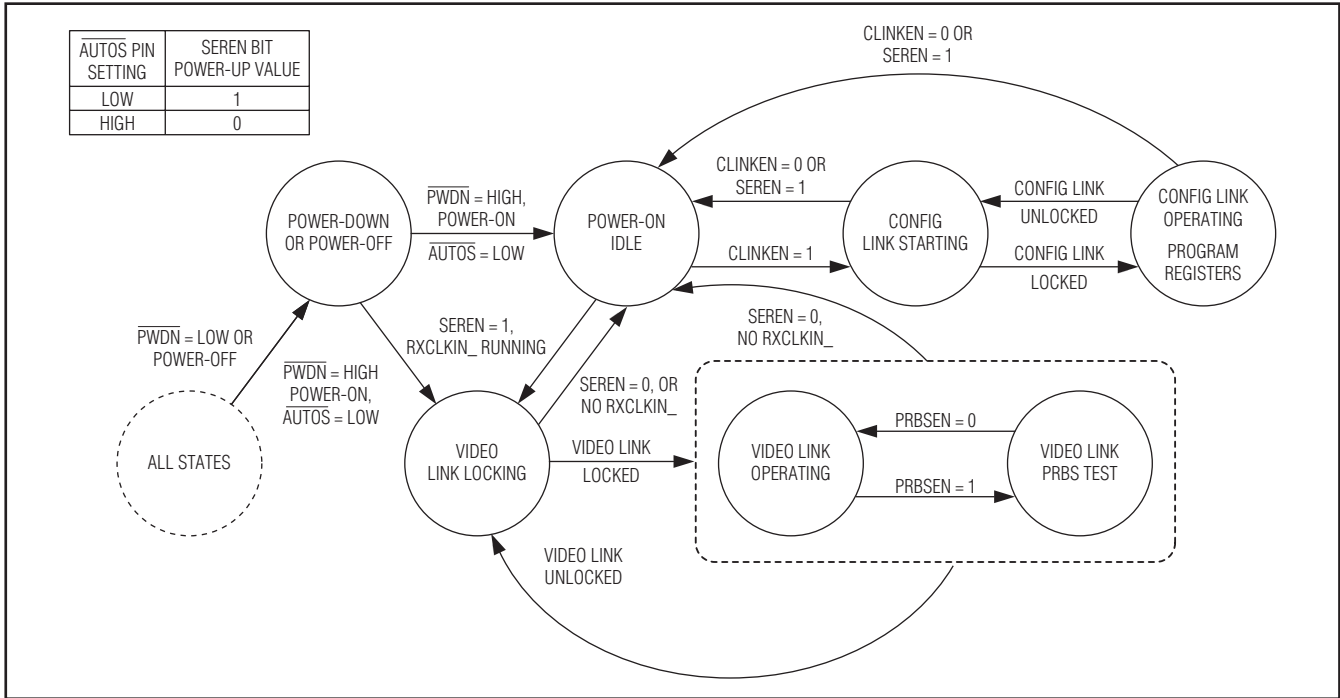

Figure 23. State Diagram, CDS = Low (LCD Application)

Table 9. Startup Selection for Image-Sensing Applications (CDS = High)

CASE	$\overline{\text{AUTOS}}$ (MAX9249)	MAX9249 POWER-UP STATE	GMSL DESERIALIZER POWER-UP STATE	LINK STARTUP MODE
1	Low	Serialization enabled	Normal (SLEEP = 0)	Autostart
2	High	Sleep mode (SLEEP = 1)	Normal (SLEEP = 0)	MAX9249 is in sleep mode. Wake up the MAX9249 through the control channel (μC attached to the GMSL deserializer).

Case 2: Standby Start Mode

After power-up or when $\overline{\text{PWDN}}$ transitions from low to high for both the serializer and deserializer, the GMSL deserializer starts up in sleep mode, and the MAX9249 stays in standby mode (does not send serial data). Use the μC and program the MAX9249 to set SEREN = 1 to establish a video link or CLINKEN = 1 to establish the configuration link. After locking to a stable RXCLKIN_ (for SEREN = 1) or the internal oscillator (for CLINKEN = 1), the MAX9249 sends a wake-up signal to the deserializer. The GMSL deserializer exits sleep mode after locking to the serial data and sets SLEEP = 0. If after 8ms the deserializer does not lock to the input serial data, the GMSL deserializer goes back to sleep, and the internal sleep bit remains set (SLEEP = 1).

Case 3: Remote Side Autostart Mode

After power-up or when $\overline{\text{PWDN}}$ transitions from low to high, the remote device (GMSL deserializer) starts up and tries to lock to an incoming serial signal with sufficient power. The host side (MAX9249) is in standby mode and does not try to establish a link. Use the μC and program the MAX9249 to set SEREN = 1 (and apply a stable RXCLKIN_) to establish a video link or CLINKEN = 1 to establish the configuration link. In this case, the GMSL deserializer ignores the short wake-up signal sent from MAX9249.

Gigabit Multimedia Serial Link Serializer with LVDS System Interface

MAX9249

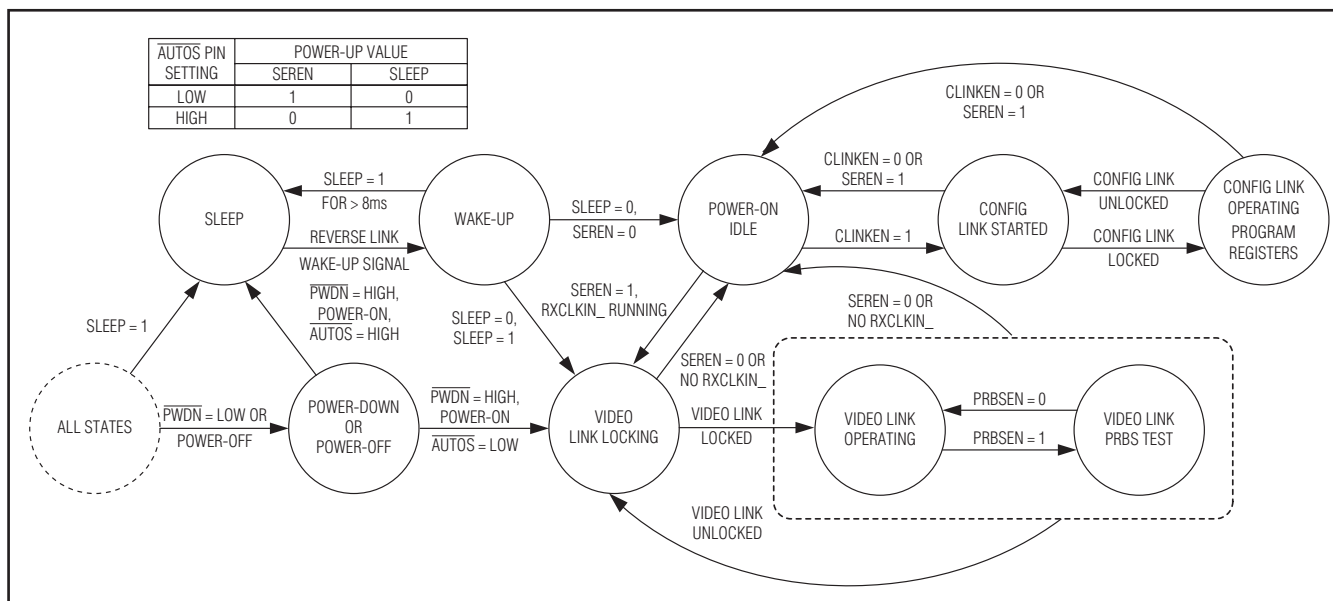

Figure 24. State Diagram, CDS = High (Camera Application)

Case 4: Remote Side in Sleep Mode

After power-up or when $\overline{\text{PWDN}}$ transitions from low to high, the remote device (GMSL deserializer) starts up in sleep mode. The high-speed link establishes automatically after MAX9249 powers up with a stable RXCLKIN_- and sends a wake-up signal to the GMSL deserializer. Use this mode in applications where the GMSL deserializer powers up before the MAX9249.

Image-Sensing Applications

For image-sensing applications, connect the μC to the GMSL deserializer and set CDS = high for both the MAX9249 and GMSL deserializer. The GMSL deserializer powers up normally ($\text{SLEEP} = 0$) and continuously tries to lock to a valid serial input. Table 9 summarizes both startup cases, based on the state of the MAX9249 AUTOS pin.

Case 1: Autostart Mode

After power-up, or when $\overline{\text{PWDN}}$ transitions from low to high, the MAX9249 locks to a stable RXCLKIN_- and sends the high-speed data to the GMSL deserializer. The GMSL deserializer locks to the serial data and outputs the video data and clock.

Case 2: Sleep Mode

After power-up or when $\overline{\text{PWDN}}$ transitions from low to high, the MAX9249 starts up in sleep mode. To wake up the MAX9249, use the μC to send a GMSL protocol UART

frame containing at least three rising edges (e.g., 0x66), at a bit rate no greater than 1Mbps. The low-power wake-up receiver of the MAX9249 detects the wake-up frame over the reverse control channel and powers up. Reset the sleep bit ($\text{SLEEP} = 0$) of the MAX9249 using a regular control channel write packet to power up the device fully. Send the sleep bit write packet at least 500 μs after the wake-up frame. The MAX9249 goes back to sleep mode if its sleep bit is not cleared within 5ms (min) after detecting a wake-up frame.

Applications Information

Self-PRBS Test

The MAX9249/GMSL deserializer link includes a PRBS pattern generator and bit-error verification function. Set $\text{PRBSEN} = 1$ (0x04 D5) first in the MAX9249 and then the GMSL deserializer to start the PRBS test. Set $\text{PRBSEN} = 0$ (0x04 D5) first in the GMSL deserializer and then the MAX9249 to exit the PRBS self-test. The GMSL deserializer uses an 8-bit register (0x0E) to count the number of detected errors. The control link also controls the start and stop of the error counting. During PRBS mode, the device does not count decoding errors and the GMSL deserializer $\overline{\text{ERR}}$ output reflects PRBS errors only. Refer to the respective GMSL deserializer data sheet for more details.

Gigabit Multimedia Serial Link Serializer with LVDS System Interface

Microcontrollers on Both Sides of the GMSL Link (Dual μ C Control)

Usually the microcontroller is either on the serializer (MAX9249) side for video-display applications or on the deserializer side for image-sensing applications. For the former case, both the CDS pins of the MAX9249/GMSL deserializer are set to low, and for the latter case, the CDS pins are set to high. However, if the CDS pin of the MAX9249 is low and the same pin of the GMSL deserializer is high, then the MAX9249/GMSL deserializer connect to both μ Cs simultaneously. In such a case, the μ Cs on either side can communicate with the MAX9249/GMSL deserializer.

Contentions of the control link can happen if the μ Cs on both sides are using the link at the same time. The MAX9249/GMSL deserializer do not provide the solution for contention avoidance. The serializer/deserializer do not send an acknowledge frame when communication fails due to contention. Users can always implement a higher layer protocol to avoid the contention. In addition, if UART communication across the serial link is not required, the μ Cs can disable the forward and reverse control channel through the REVCCEN and FWDCEN bits (0x04 D[1:0]) in the MAX9249/GMSL deserializer. UART communication across the serial link is stopped and contention between μ Cs no longer occurs. During dual μ Cs operation, if one of the CDS pins on either side changes state, the link resumes the corresponding state described in the *Link Startup Procedure* section.

As an example of dual μ C use in an image-sensing application, the MAX9249 can be in sleep mode and waiting for wake-up by the GMSL deserializer. After wake-up, the serializer-side μ C sets the MAX9249 CDS pin low and assumes master control of the MAX9249 registers.

Jitter-Filtering PLL

In some applications, the input clock to the MAX9249 (RXCLKIN_) includes jitter that reduces link reliability. The MAX9249 has a programmable narrow-band jitter-filtering PLL to attenuate frequency components outside the PLL's bandwidth (< 100kHz, typ). Enable the jitter-filtering PLL by setting DISFPLL = 0 (0x05 D6).

Changing the Clock Frequency

Both the video clock rate ($f_{RXCLKIN_}$) and the control-channel clock rate (f_{UART}) can be changed on-the-fly to support applications with multiple clock speeds. It is recommended to enable the serial link after RXCLKIN_ stabilizes. Stop RXCLKIN_ for 5 μ s and restart the serial link or toggle SEREN after each change in the RXCLKIN_ frequency to recalibrate any automatic settings if a clean frequency change cannot be guaranteed. The reverse control channel remains unavailable for 350 μ s after serial link start or stop. Limit on-the-fly changes in f_{UART} to factors of less than 3.5 at a time to ensure that the device recognizes the UART sync pattern. For example, when lowering the UART frequency from 1Mbps to 100kbps, first send data at 333kbps and then at 100kbps to have reduction ratios of 3 and 3.333, respectively.

LOCK Output Loopback

For quick loss-of-lock notification, the GMSL deserializer can loop back its LOCK output to the MAX9249 using the INT signal. Connect the LOCK output to the INT input of the GMSL deserializer. The interrupt output on the MAX9249 follows the transitions at the LOCK output of the GMSL deserializer. Reverse control-channel communication does not require an active forward link to operate and accurately tracks the LOCK status of the video link. LOCK asserts for video link only and not for the configuration link.

Line-Fault Detection

The line-fault detector in the MAX9249 monitors for line failures such as short to ground, short to power supply, and open link for system fault diagnosis. Figure 3 shows the required external resistor connections. \overline{LFLT} = low when a line fault is detected and \overline{LFLT} = high when the line returns to normal. The line-fault type is stored in 0x08 D[3:0] of the MAX9249. The fault-detector threshold voltages are referenced to the MAX9249 ground. Additional passive components set the DC level of the cable (Figure 3). If the MAX9249 and GMSL deserializer grounds are different, the link DC voltage during normal operation can vary and cross one of the fault-detection thresholds. For the fault-detection circuit, select the resistor's power rating to handle a short to the battery and use surface-mount resistors with small case size to minimize parasitic effects to the high-speed signal. Table 10 lists the mapping for line-fault types.

Gigabit Multimedia Serial Link Serializer with LVDS System Interface

Table 10. Line-Fault Mapping

REGISTER ADDRESS	BITS	NAME	VALUE	LINE-FAULT TYPE
0x08	D[3:2]	LFNEG	00	Negative cable wire shorted to battery
			01	Negative cable wire shorted to ground
			10	Normal operation
			11	Negative cable wire open
	D[1:0]	LFPOS	00	Positive cable wire shorted to battery
			01	Positive cable wire shorted to ground
			10	Normal operation
			11	Positive cable wire open

Choosing I²C/UART Pullup Resistors

Both I²C/UART open-drain lines require pullup resistors to provide a logic-high level. There are trade-offs between power dissipation and speed, and a compromise made in choosing pullup resistor values. Every device connected to the bus introduces some capacitance even when the device is not in operation. I²C specifies 300ns rise times to go from low to high (30% to 70%) for fast mode, which is defined for data rates up to 400kbps (see the I²C specifications in the *AC Electrical Characteristics* section for details). To meet the fast-mode rise-time requirement, choose the pullup resistors so that rise time $t_R = 0.85 \times R_{PULLUP} \times C_{BUS} < 300ns$. The waveforms are not recognized if the transition time becomes too slow. The MAX9249 supports I²C/UART rates up to 1Mbps.

AC-Coupling

AC-coupling isolates the receiver from DC voltages up to the voltage rating of the capacitor. Four capacitors—two at the serializer output and two at the deserializer input—are needed for proper link operation and to provide protection if either end of the cable is shorted to a high voltage. AC-coupling blocks low-frequency ground shifts and low-frequency common-mode noise.

Selection of AC-Coupling Capacitors

Voltage droop and the digital sum variation (DSV) of transmitted symbols cause signal transitions to start from different voltage levels. Because the transition time is finite, starting the signal transition from different voltage levels causes timing jitter. The time constant for an AC-coupled link needs to be chosen to reduce droop

and jitter to an acceptable level. The RC network for an AC-coupled link consists of the CML receiver termination resistor (RTR), the CML driver termination resistor (RTD), and the series AC-coupling capacitors (C). The RC time constant for four equal-value series capacitors is $(C \times (RTD + RTR))/4$. RTD and RTR are required to match the transmission line impedance (usually 100Ω). This leaves the capacitor selection to change the system time constant. Use at least 0.2μF high-frequency surface-mount ceramic capacitors, with sufficient voltage rating to withstand a short to battery, to pass the lower speed reverse control-channel signal. Use capacitors with a case size less than 3.2mm x 1.6mm to have lower parasitic effects to the high-speed signal.

Power-Supply Circuits and Bypassing

The MAX9249 uses a VAVDD and VDVDD of 1.7V to 1.9V, and a VLVDSVDD of 3.0V to 3.6V. All single-ended inputs and outputs on the MAX9249 derive power from a VIOVDD of 1.7V to 3.6V, which scale with IOVDD. Proper voltage-supply bypassing is essential for high-frequency circuit stability.

Cables and Connectors

Interconnect for CML typically has a differential impedance of 100Ω. Use cables and connectors that have matched differential impedance to minimize impedance discontinuities. Twisted-pair and shielded twisted-pair cables tend to generate less EMI due to magnetic-field canceling effects. Balanced cables pick up noise as common mode rejected by the CML receiver. Table 11 lists the suggested cables and connectors used in the GMSL link.

Gigabit Multimedia Serial Link Serializer with LVDS System Interface

Table 11. Suggested Connectors and Cables for GMSL

VENDOR	CONNECTOR	CABLE
JAE Electronics, Inc.	MX38-FF	A-BW-Lxxxxx
Nissei Electric Co., Ltd.	GT11L-2S	F-2WME AWG28
Rosenberger Hochfrequenztechnik GmbH	D4S10A-40ML5-Z	Dacar 538

Board Layout

Separate the digital signals and CML/LVDS high-speed signals to prevent crosstalk. Use a four-layer PCB with separate layers for power, ground, CML/LVDS, and digital signals. Layout PCB traces close to each other for a 100Ω differential characteristic impedance. The trace dimensions depend on the type of trace used (microstrip or stripline). Note that two 50Ω PCB traces do not have 100Ω differential impedance when brought close together—the impedance goes down when the traces are brought closer.

Route the PCB traces for a CML/LVDS channel (there are two conductors per CML/LVDS channel) in parallel to maintain the differential characteristic impedance. Avoid vias. Keep PCB traces that make up a differential pair equal length to avoid skew within the differential pair.

ESD Protection

The MAX9249 ESD tolerance is rated for Human Body Model, IEC 61000-4-2, and ISO 10605. The ISO 10605 and IEC 61000-4-2 standards specify ESD tolerance for electronic systems. CML/LVDS I/O are tested for ISO 10605 ESD protection and IEC 61000-4-2 ESD protection. All pins are tested for the Human Body Model. The Human Body Model discharge components are $C_S = 100\text{pF}$ and $R_D = 1.5\text{k}\Omega$ (Figure 25). The IEC 61000-4-2 discharge components are $C_S = 150\text{pF}$ and $R_D = 330\Omega$ (Figure 26). The ISO 10605 discharge components are $C_S = 330\text{pF}$ and $R_D = 2\text{k}\Omega$ (Figure 27).

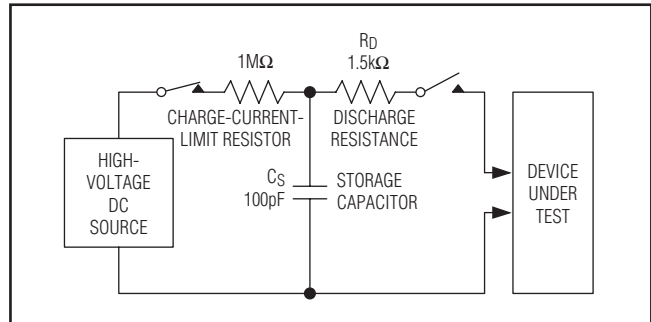

Figure 25. Human Body Model ESD Test Circuit

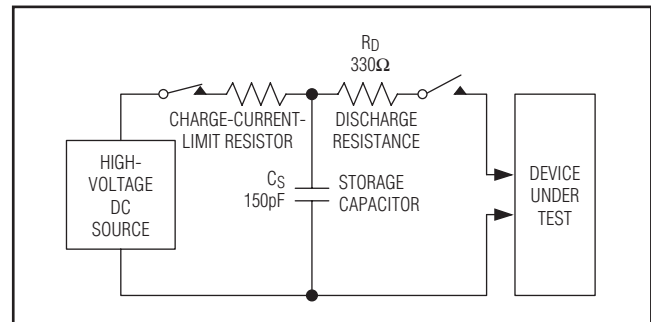

Figure 26. IEC 61000-4-2 Contact Discharge ESD Test Circuit

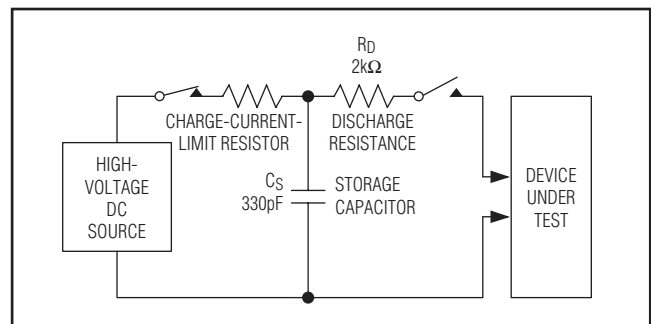

Figure 27. ISO 10605 Contact Discharge ESD Test Circuit

Gigabit Multimedia Serial Link Serializer with LVDS System Interface

Table 12. Register Table (See Table 1 for Default Value Details)

REGISTER ADDRESS	BITS	NAME	VALUE	FUNCTION	DEFAULT VALUE
0x00	D[7:1]	SERID	XXXXXXX	Serializer device address	1000000
	D0	—	0	Reserved	0
0x01	D[7:1]	DESID	XXXXXXX	Deserializer device address	1001000
	D0	—	0	Reserved	0
0x02	D[7:5]	SS	000	No spread spectrum. Power-up default when SSEN = low.	000, 001
			001	±0.5% spread spectrum. Power-up default when SSEN = high.	
			010	±1.5% spread spectrum	
			011	±2% spread spectrum	
			100	No spread spectrum	
			101	±1% spread spectrum	
			110	±3% spread spectrum	
			111	±4% spread spectrum	
	D4	AUDIOEN	0	Disable I ² S channel	1
			1	Enable I ² S channel	
	D[3:2]	PRNG	00	12.5MHz to 25MHz pixel clock	11
			01	25MHz to 50MHz pixel clock	
			10	50MHz to 104MHz pixel clock	
			11	Automatically detect the pixel clock range	
	D[1:0]	SRNG	00	0.5 to 1Gbps serial-bit rate	11
			01	1 to 2Gbps serial-bit rate	
10			2 to 3.125Gbps serial-bit rate		
11			Automatically detect serial-bit rate		
0x03	D[7:6]	AUTOFM	00	Calibrate spread-modulation rate only once after locking	00
			01	Calibrate spread-modulation rate every 2ms after locking	
			10	Calibrate spread-modulation rate every 16ms after locking	
			11	Calibrate spread-modulation rate every 256ms after locking	
	D[5:0]	SDIV	000000	Autocalibrate sawtooth divider	000000
XXXXXX			Manual SDIV setting. See the <i>Manual Programming of the Spread-Spectrum Divider</i> section.		

Gigabit Multimedia Serial Link Serializer with LVDS System Interface

Table 12. Register Table (See Table 1 for Default Value Details) (continued)

REGISTER ADDRESS	BITS	NAME	VALUE	FUNCTION	DEFAULT VALUE
0x04	D7	SEREN	0	Disable serial link. Power-up default when AUTOS = high. Reverse control-channel communication remains unavailable for 350µs after the MAX9249 starts/stops the serial link.	0, 1
			1	Enable serial link. Power-up default when AUTOS = low. Reverse control-channel communication remains unavailable for 350µs after the MAX9249 starts/stops the serial link.	
	D6	CLINKEN	0	Disable configuration link	0
			1	Enable configuration link	
	D5	PRBSEN	0	Disable PRBS test	0
			1	Enable PRBS test	
	D4	SLEEP	0	Normal mode. Default value depends on CDS and AUTOS pin values at power-up.	0, 1
			1	Activate sleep mode. Default value depends on CDS and $\overline{\text{AUTOS}}$ pin values at power-up.	
	D[3:2]	INTTYPE	00	Base mode uses I ² C peripheral interface	00
			01	Base mode uses UART peripheral interface	
			10, 11	Base mode peripheral interface disabled	
	D1	REVCCEN	0	Disable reverse control channel from deserializer (receiving)	1
			1	Enable reverse control channel from deserializer (receiving)	
	D0	FWDCEN	0	Disable forward control channel to deserializer (sending)	1
1			Enable forward control channel to deserializer (sending)		

Gigabit Multimedia Serial Link Serializer with LVDS System Interface

MAX9249

Table 12. Register Table (See Table 1 for Default Value Details) (continued)

REGISTER ADDRESS	BITS	NAME	VALUE	FUNCTION	DEFAULT VALUE
0x05	D7	I2CMETHOD	0	I ² C conversion sends the register address	0
			1	Disable sending of I ² C register address (command-byte-only mode)	
	D6	DISFPLL	0	Filter PLL active	1
			1	Filter PLL disabled	
	D[5:4]	CMLLVL	00	Do not use	11
			01	200mV CML signal level	
			10	300mV CML signal level	
			11	400mV CML signal level	
	D[3:0]	PREEMP	0000	Preemphasis off	0000
			0001	-1.2dB preemphasis	
			0010	-2.5dB preemphasis	
			0011	-4.1dB preemphasis	
			0100	-6.0dB preemphasis	
			0101	Do not use	
			0110	Do not use	
			0111	Do not use	
			1000	1.1dB preemphasis	
			1001	2.2dB preemphasis	
			1010	3.3dB preemphasis	
			1011	4.4dB preemphasis	
1100			6.0dB preemphasis		
1101			8.0dB preemphasis		
1110	10.5dB preemphasis				
1111	14.0dB preemphasis				
0x06	D[7:0]	—	01000000	Reserved	01000000
0x07	D[7:0]	—	00100010	Reserved	00100010
0x08	D[7:4]	—	0000	Reserved	0000 (read only)
	D[3:2]	LFNEG	00	Negative cable wire shorted to battery	10 (read only)
			01	Negative cable wire shorted to ground	
			10	Normal operation	
			11	Negative cable wire open	
	D[1:0]	LFPOS	00	Positive cable wire shorted to battery	10 (read only)
			01	Positive cable wire shorted to ground	
			10	Normal operation	
11			Positive cable wire open		
0x0C	D[7:0]	—	01110000	Reserved	01110000

Gigabit Multimedia Serial Link Serializer with LVDS System Interface

Table 12. Register Table (See Table 1 for Default Value Details) (continued)

REGISTER ADDRESS	BITS	NAME	VALUE	FUNCTION	DEFAULT VALUE
0x0D	D7	SETINT	0	Set INT low when SETINT transitions from 1 to 0	0
			1	Set INT high when SETINT transitions from 0 to 1	
	D[6:5]	—	00	Reserved	00
	D4	DISRES	0	RES (LVDS interface) mapped to DIN27	0
			1	CNTL1 mapped to DIN27	
	D[3:0]	SKEWADJ	0000	Adjust x7 PLL clock skew + 50ps	1111
			0001	Adjust x7 PLL clock skew + 100ps	
			0010	Adjust x7 PLL clock skew + 200ps	
			0011	Adjust x7 PLL clock skew + 250ps	
			0100	Adjust x7 PLL clock skew + 300ps	
			0101	Adjust x7 PLL clock skew + 350ps	
			0110	Adjust x7 PLL clock skew + 400ps	
			0111	Do not use	
			1000	Adjust x7 PLL clock skew - 50ps	
			1001	Adjust x7 PLL clock skew - 100ps	
			1010	Adjust x7 PLL clock skew - 200ps	
			1011	Adjust x7 PLL clock skew - 250ps	
			1100	Adjust x7 PLL clock skew - 300ps	
1101			Adjust x7 PLL clock skew - 350ps		
1110			Adjust x7 PLL clock skew - 400ps		
1111			No x7PLL clock skew adjustment		
0x1E	D[7:0]	ID	00000011	Device identifier (MAX9249 = 0x03)	00000011 (read only)
0x1F	D[7:4]	—	0000	Reserved	0000 (read only)
	D[3:0]	REVISION	XXXX	Device revision	(read only)

X = Don't care.

Gigabit Multimedia Serial Link Serializer with LVDS System Interface

Typical Application Circuit

MAX9249

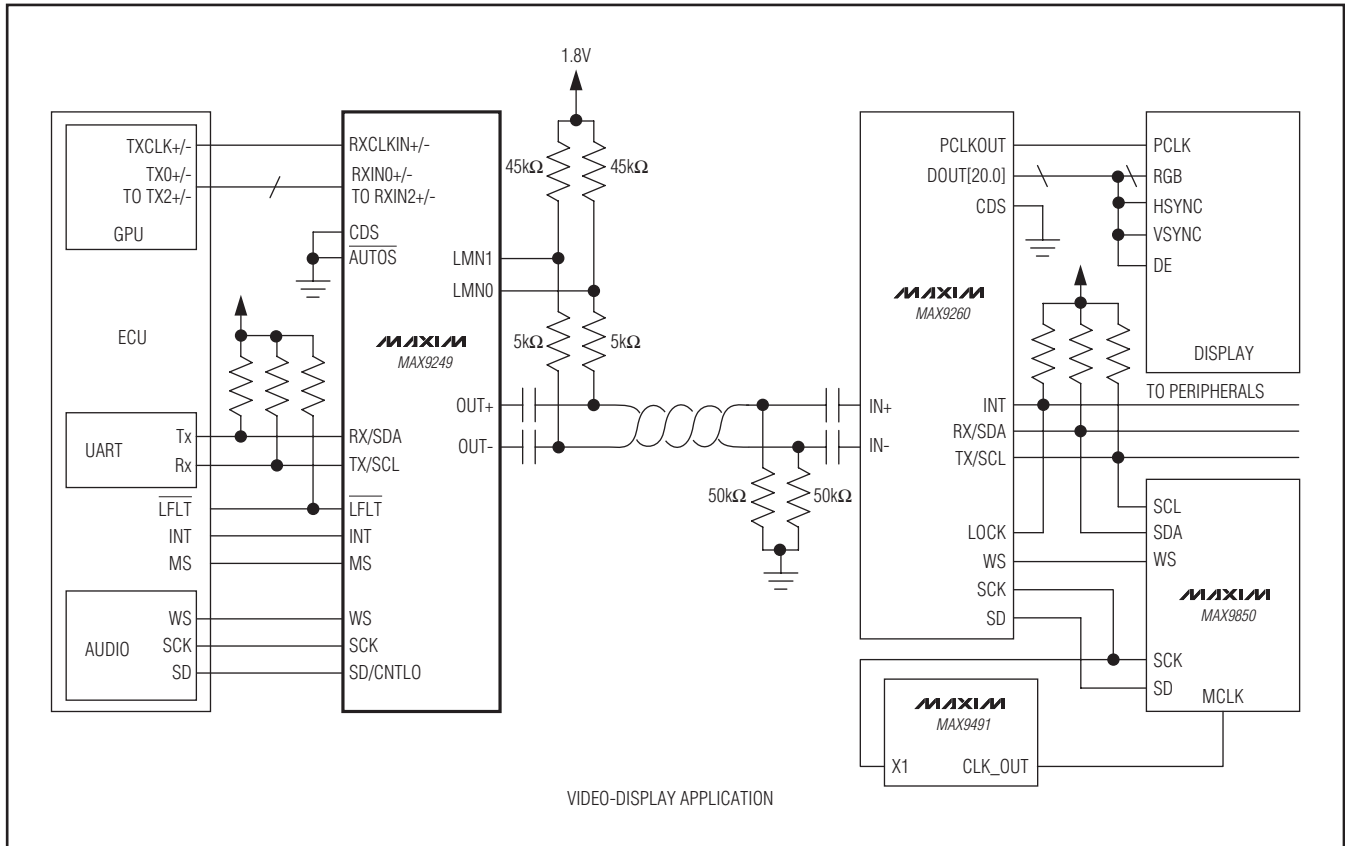

Chip Information

PROCESS: CMOS

Package Information

For the latest package outline information and land patterns (footprints), go to www.maxim-ic.com/packages. Note that a "+", "#", or "-" in the package code indicates RoHS status only. Package drawings may show a different suffix character, but the drawing pertains to the package regardless of RoHS status.

PACKAGE TYPE	PACKAGE CODE	OUTLINE NO.	LAND PATTERN NO.
48 TQFP-EP	C48E+8	21-0065	90-0138

Gigabit Multimedia Serial Link Serializer with LVDS System Interface

Revision History

REVISION NUMBER	REVISION DATE	DESCRIPTION	PAGES CHANGED
0	1/10	Initial release	—
1	3/10	Improved yield	2, 3
2	5/10	Added soldering temperature (reflow) to the <i>Absolute Maximum Ratings</i> section and corrected spread-spectrum modulation settings in Table 7	2, 24
3	1/11	Added Patent Pending to <i>Features</i>	1
4	1/12	Corrected GND to AGND in <i>Absolute Maximum Ratings</i>	2

Maxim cannot assume responsibility for use of any circuitry other than circuitry entirely embodied in a Maxim product. No circuit patent licenses are implied. Maxim reserves the right to change the circuitry and specifications without notice at any time.

36 **Maxim Integrated Products, 120 San Gabriel Drive, Sunnyvale, CA 94086 408-737-7600**

Looking for pricing, stock, or lifecycle information?

Click below to explore more details on WIN SOURCE:

- ⊖ [View MAX9249GCM/V+T on WIN SOURCE](#)
- ⊖ [Maxim Integrated Information](#)

Optimize Your Supply Chain with WIN SOURCE Solutions

- ✓ Global Sourcing Solution
- ✓ Obsolete Management
- ✓ Cost Control Management
- ✓ Shortage Management
- ✓ Alternative Solution
- ✓ Excess Inventory Management