



**THE DATASHEET OF
MAX9667ETP+T**





6/8/10-Channel, 10-Bit, Nonvolatile Programmable Gamma and VCOM Reference Voltages

General Description

The MAX9665/MAX9666/MAX9667 provide multiple programmable reference voltages for gamma correction in TFT LCDs and a programmable reference voltage for VCOM adjustment. All gamma and VCOM reference voltages have a 10-bit digital-to-analog converter (DAC) and buffer with high peak current. This reduces the recovery time of the output voltage when critical levels and patterns are displayed.

These devices include multiple-time programmable (MTP) memory to store gamma and VCOM codes on the chip, eliminating the need for external EEPROM. The MTP memory supports up to 300 write operations.

The MAX9665/MAX9666/MAX9667 feature an I²C interface to control the programmable reference voltages and a single-wire interface to toggle the VCOM reference voltage up or down.

Applications

TFT LCDs

Ordering Information

PART	GAMMA CHANNELS	TEMP RANGE	PIN-PACKAGE
MAX9665ETP+	6	-40°C to +85°C	20 TQFN-EP*
MAX9666ETP+	8	-40°C to +85°C	20 TQFN-EP*
MAX9667ETP+	10	-40°C to +85°C	20 TQFN-EP*

+Denotes a lead(Pb)-free/RoHS-compliant package.

*EP = Exposed pad.

Pin Configurations

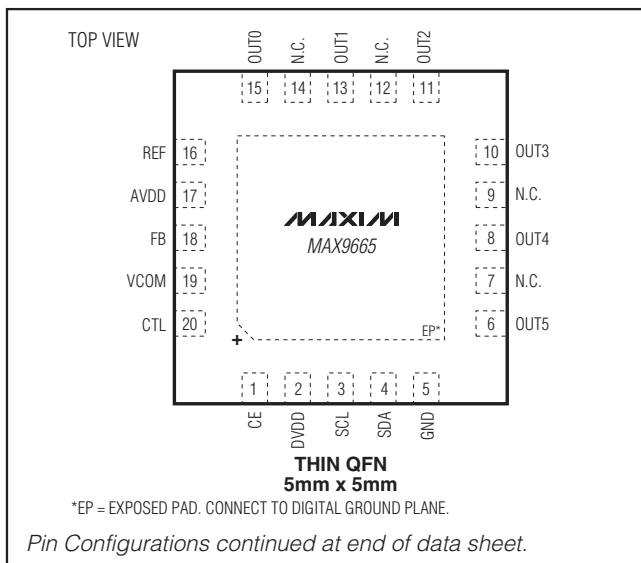

Features

- ◆ 6/8/10 Channels Gamma Correction, 10-Bit Resolution
- ◆ VCOM Driver
- ◆ Integrated Multiple-Time Programmable Memory
- ◆ DAC Reference Input
- ◆ Single-Wire and I²C Programming of VCOM Reference
- ◆ 950mA Peak Transient Current on VCOM Channel

Functional Diagrams

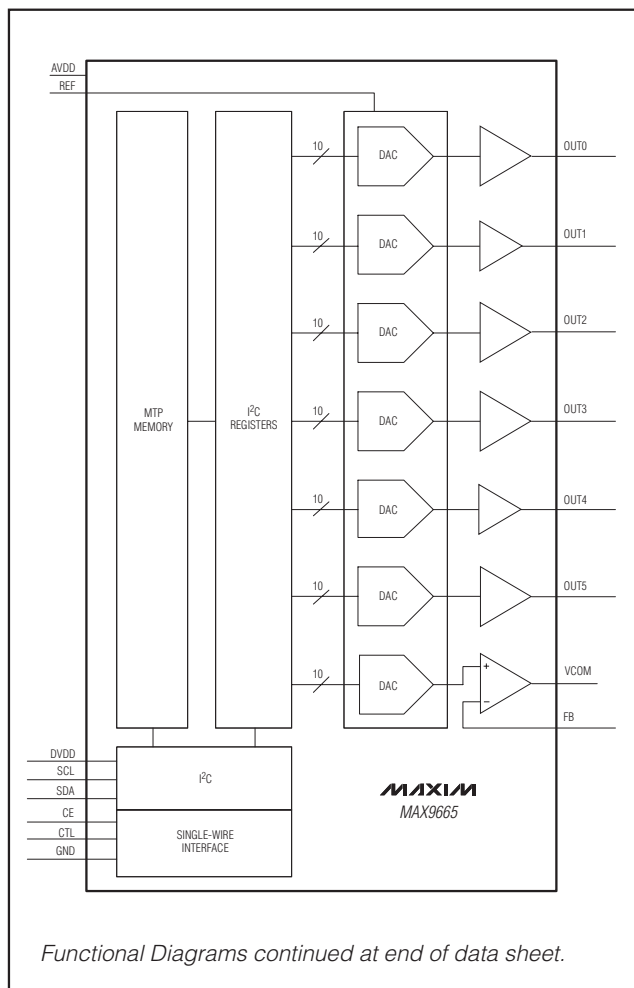

MAX9665/MAX9666/MAX9667



6/8/10-Channel, 10-Bit, Nonvolatile Programmable Gamma and VCOM Reference Voltages

ABSOLUTE MAXIMUM RATINGS

Supply Voltages		Continuous Power Dissipation ($T_A = +70^\circ\text{C}$)
AVDD to GND.....	-0.3V to +22V	20-Pin TQFN (derate 25.6mW/°C above +70°C)2051.3mW
DVDD to GND.....	-0.3V to +4V	Junction-to-Case Thermal Resistance (θ_{JC}) (Note 1)
Outputs		20-Pin TQFN.....6°C/W
OUT0–OUT9, VCOM to GND	-0.3V to ($V_{AVDD} + 0.3V$)	Junction-to-Ambient Thermal Resistance (θ_{JA}) (Note 1)
Inputs		20-Pin TQFN.....39°C/W
SDA, SCL, CE to GND.....	-0.3V to +4V	Operating Temperature Range
CTL, REF to GND	-0.3V to +22V	-40°C to +85°C
FB to GND	-0.3V to ($V_{AVDD} + 0.3V$)	Junction Temperature.....
Continuous Current		+150°C
OUT0–OUT9, VCOM.....	±400mA	Storage Temperature Range
All Other Pins	±50mA	-65°C to +150°C
		Lead Temperature (soldering, 10s)
		+300°C
		Soldering Temperature (reflow)
		+260°C

Note 1: Package thermal resistances were obtained using the method described in JEDEC specification JESD51-7, using a four-layer board. For detailed information on package thermal considerations, refer to www.maxim-ic.com/thermal-tutorial.

Stresses beyond those listed under “Absolute Maximum Ratings” may cause permanent damage to the device. These are stress ratings only, and functional operation of the device at these or any other conditions beyond those indicated in the operational sections of the specifications is not implied. Exposure to absolute maximum rating conditions for extended periods may affect device reliability.

ELECTRICAL CHARACTERISTICS

($V_{AVDD} = V_{REF} = 15.7V$, $V_{DVDD} = 3.3V$, $V_{GND} = 0V$, VCOM connected to FB, CTL = DVDD/2, no load, $T_A = -40^\circ\text{C}$ to $+85^\circ\text{C}$, unless otherwise noted. Typical values are at $T_A = +25^\circ\text{C}$.) (Note 2)

PARAMETER	SYMBOL	CONDITIONS	MIN	TYP	MAX	UNITS
SUPPLIES						
Analog-Supply Voltage Range	V_{AVDD}	Guaranteed by power-supply rejection ratio specification (Note 3)	9		20	V
Analog-Supply Voltage Range for Programming MTP	V_{AVDD_MTP}		15		20	V
Digital-Supply Voltage Range	V_{DVDD}		2.7		3.6	V
Analog Quiescent Current	I_{AVDD}	MAX9665		12	22	mA
		MAX9666		14	24	
		MAX9667		16	26	
Digital Quiescent Current	I_{DVDD}	No SCL or SDA transitions		450	900	μA
DVDD Undervoltage Lockout	UVLO			2.3	2.6	V
DAC						
Resolution			10			Bits
Integral Nonlinearity Error	INL	$T_A = +25^\circ\text{C}$, $16 \leq \text{CODE} \leq 1008$			1	LSB
Differential Nonlinearity Error	DNL	$T_A = +25^\circ\text{C}$, $16 \leq \text{CODE} \leq 1008$			1	LSB
REF Input Resistance				384		k Ω
GAMMA OUTPUTS (Note 4)						
Short-Circuit Current	I_{SC}	Output to AVDD or GND, $T_A = +25^\circ\text{C}$	100	400		mA
Maximum Capacitive Load		Placed directly at output		300		pF
Output Impedance	Z_O	Output resistance when output is disabled		84		k Ω
Load Regulation	R_{EG}	-5mA to +5mA		0.5		mV/mA
Total Output Error		$T_A = +25^\circ\text{C}$, measured at code = 512	-40		+40	mV
Slew Rate	SR	5V swing, measure 10% to 90%		22		V/ μs

6/8/10-Channel, 10-Bit, Nonvolatile Programmable Gamma and VCOM Reference Voltages

ELECTRICAL CHARACTERISTICS (continued)

($V_{AVDD} = V_{REF} = 15.7V$, $V_{DVDD} = 3.3V$, $V_{GND} = 0V$, VCOM connected to FB, CTL = DVDD/2, no load, $T_A = -40^{\circ}C$ to $+85^{\circ}C$, unless otherwise noted. Typical values are at $T_A = +25^{\circ}C$.) (Note 2)

PARAMETER	SYMBOL	CONDITIONS	MIN	TYP	MAX	UNITS
Low Output Voltage	V_{MIN}	Sinking 4mA, $T_A = +25^{\circ}C$		0.1	0.15	V
High Output Voltage	V_{MAX}	Sourcing 4mA, $T_A = +25^{\circ}C$	$V_{AVDD} - 0.15$	$V_{AVDD} - 0.1$		V
Power-Supply Rejection Ratio	PSRR	To AVDD, $f = 60kHz$, REF and AVDD shorted		40		dB
		$9V < V_{AVDD} < 20V$, $V_{REF} = 9V$	60	90		
Channel-to-Channel Isolation	C_{XTLK}	$f = 5MHz$, all channels to all channels		80		dB
GAMMA OUTPUTS (Note 5)						
Short-Circuit Current	I_{SC}	Outputs to AVDD or GND, $T_A = +25^{\circ}C$	50	200		mA
Maximum Capacitive Load		Placed directly at output		300		pF
Output Impedance	Z_O	Output resistance when output is disabled		84		$k\Omega$
Load Regulation	REG	-5mA to +5mA		0.50		mV/mA
Total Output Error		$T_A = +25^{\circ}C$, measured at code = 512	-40		+40	mV
Slew Rate	SR	Swing $5V_{P-P}$ at input, 10% to 90% measurement on output		22		V/ μs
Low Output Voltage	V_{MIN}	Sinking 4mA		0.15	0.2	V
High Output Voltage	V_{MAX}	Sourcing 4mA	$V_{AVDD} - 0.2$	$V_{AVDD} - 0.15$		V
Power-Supply Rejection Ratio	PSRR	To AVDD, $f = 60kHz$, REF and AVDD shorted		40		dB
		$9V < V_{AVDD} < 20V$, $V_{REF} = 9V$	60	90		
Thermal Shutdown				160		$^{\circ}C$
Thermal-Shutdown Hysteresis				15		$^{\circ}C$
Channel-to-Channel Isolation	C_{XTLK}	$f = 5MHz$, all channels to all channels		80		dB
VCOM OUTPUT						
Short-Circuit Current	I_{SC}	Outputs to AVDD or GND, $T_A = +25^{\circ}C$	50	200		mA
Maximum Capacitive Load		Placed directly at output		300		pF
Output Impedance	Z_O	Output resistance when output is disabled		84		$k\Omega$
Load Regulation	REG	-5mA to +5mA		± 0.2		mV/mA
Total Output Error		$T_A = +25^{\circ}C$, measured at code = 512	-50	1	+50	mV
Slew Rate	SR	Swing $4V_{P-P}$ at VCOM, 10% to 90%, $R_L = 10k\Omega$, $C_L = 50pF$ (Note 6)		100		V/ μs
Low Output Voltage	V_{MIN}	Sinking 4mA		0.15	0.2	V
High Output Voltage	V_{MAX}	Sourcing 4mA	$V_{AVDD} - 0.2$	$V_{AVDD} - 0.15$		V
Power-Supply Rejection Ratio	PSRR	To AVDD, $f = 60kHz$, REF and AVDD shorted		40		dB
		$9V < V_{AVDD} < 20V$, $V_{REF} = 9V$	70			

MAX9665/MAX9666/MAX9667

6/8/10-Channel, 10-Bit, Nonvolatile Programmable Gamma and VCOM Reference Voltages

ELECTRICAL CHARACTERISTICS (continued)

($V_{AVDD} = V_{REF} = 15.7V$, $V_{DVDD} = 3.3V$, $V_{GND} = 0V$, VCOM connected to FB, CTL = DVDD/2, no load, $T_A = -40^{\circ}C$ to $+85^{\circ}C$, unless otherwise noted. Typical values are at $T_A = +25^{\circ}C$.) (Note 2)

PARAMETER	SYMBOL	CONDITIONS	MIN	TYP	MAX	UNITS
SINGLE-WIRE INTERFACE						
CE Input Low Voltage		$2.6V < V_{DVDD} < 3.6V$			$0.3 \times V_{DVDD}$	V
CE Input High Voltage		$2.6V < V_{DVDD} < 3.6V$	$0.7 \times V_{DVDD}$			V
CE Startup Time		(Note 7)			1	ms
CTL High Voltage		$2.6V < V_{DVDD} < 3.6V$	$0.7 \times V_{DVDD}$		$0.82 \times V_{DVDD}$	V
CTL Float Voltage		$2.6V < V_{DVDD} < 3.6V$	$0.4 \times V_{DVDD}$		$0.62 \times V_{DVDD}$	V
CTL Low Voltage		$2.6V < V_{DVDD} < 3.6V$	$0.2 \times V_{DVDD}$		$0.32 \times V_{DVDD}$	V
CTL Rejected Pulse Width			20			μs
CTL Typical Pulse Width				50		μs
CTL Minimum Pulse Width					200	μs
CTL Minimum Time Between Pulses					10	μs
CTL Input Current		CTL = GND	-10			μA
		CTL = DVDD			+10	
LOGIC INPUTS AND OUTPUTS (SDA, SCL)						
Input High Voltage	V_{IH}		$0.7 \times V_{DVDD}$			V
Input Low Voltage	V_{IL}				$0.3 \times V_{DVDD}$	V
Input Leakage Current	I_{IH}, I_{IL}	$V_{SDA/SCL} = 0V$ or V_{DVDD}	-10	+0.01	+10	μA
Input Capacitance		(Note 7)		5		pF
Power-Down Input Current	$I_{SDA/SCL}$	$V_{DVDD} = 0V$, $V_{SDA/SCL} = 1.98V$	-10		+10	μA
SDA Output Low Voltage	V_{OL}	$I_{SINK} = 6mA$			0.4	V

6/8/10-Channel, 10-Bit, Nonvolatile Programmable Gamma and VCOM Reference Voltages

MAX9665/MAX9666/MAX9667

ELECTRICAL CHARACTERISTICS (continued)

($V_{AVDD} = V_{REF} = 15.7V$, $V_{DVDD} = 3.3V$, $V_{GND} = 0V$, VCOM connected to FB, CTL = DVDD/2, no load, $T_A = -40^{\circ}C$ to $+85^{\circ}C$, unless otherwise noted. Typical values are at $T_A = +25^{\circ}C$.) (Note 2)

PARAMETER	SYMBOL	CONDITIONS	MIN	TYP	MAX	UNITS
I²C TIMING CHARACTERISTICS (Figure 4)						
Serial-Clock Frequency	f _{SCL}		0		400	kHz
Bus Free Time Between STOP and START Conditions	t _{BUF}		1.3			μs
Hold Time (Repeated) START Condition	t _{HD,STA}		0.6			μs
SCL Pulse-Width Low	t _{LOW}		1.3			μs
SCL Pulse-Width High	t _{HIGH}		0.6			μs
Setup Time for a Repeated START Condition	t _{SU,STA}		0.6			μs
Data Hold Time	t _{HD,DAT}		0		900	ns
Data Setup Time	t _{SU,DAT}		100			ns
SDA and SCL Receiving Rise Time	t _R	(Note 8)	20 + 0.1C _B		300	ns
SDA and SCL Receiving Fall Time	t _F	(Note 8)	20 + 0.1C _B		300	ns
SDA Transmitting Fall Time	t _{F,TX}	(Note 8)	20 + 0.1C _B		250	ns
Setup Time for STOP Condition	t _{SU,STO}		0.6			μs
Bus Capacitance	C _B				400	pF
Pulse Width of Suppressed Spike	t _{SP}		0		50	ns

Note 2: All devices are 100% production tested at $T_A = +25^{\circ}C$. Specifications over temperature limits are guaranteed by design.

Note 3: For AVDD below 15.6V, internal LDO must be externally adjusted to meet LDO dropout specification.

Note 4: This section applies to OUT0, OUT2, OUT3, and OUT5 of the MAX9665; OUT0, OUT3, OUT4, and OUT7 of the MAX9666; OUT0, OUT4, OUT5, and OUT9 of the MAX9667.

Note 5: This section applies to OUT1 and OUT4 of the MAX9665; OUT1, OUT2, OUT5, and OUT6 of the MAX9666; OUT1, OUT2, OUT3, OUT6, OUT7, and OUT8 of the MAX9667.

Note 6: Measured with the VCOM amplifier configured as an inverting unity-gain amplifier. $R_F = R_{IN} = 10k\Omega$.

Note 7: Guaranteed by design. Not production tested.

Note 8: C_B is in pF.

6/8/10-Channel, 10-Bit, Nonvolatile Programmable Gamma and VCOM Reference Voltages

Typical Operating Characteristics

($V_{AVDD} = V_{REF} = 15.7V$, $V_{DVDD} = 3.3V$, $V_{GND} = 0V$, VCOM connected to FB, CTL = DVDD/2, no load, $T_A = -40^{\circ}C$ to $+85^{\circ}C$, unless otherwise noted. Typical values are at $T_A = +25^{\circ}C$.) (Note 2)

**OUTPUT OFFSET
VOLTAGE DISTRIBUTION**

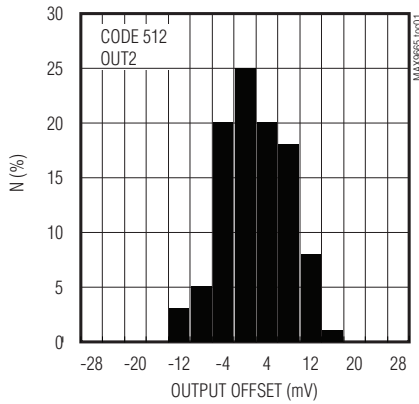

GAMMA LOAD REGULATION

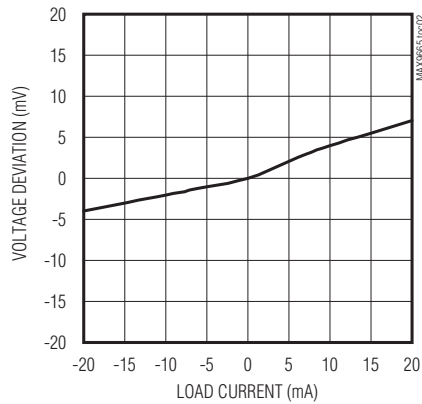

VCOM LOAD REGULATION

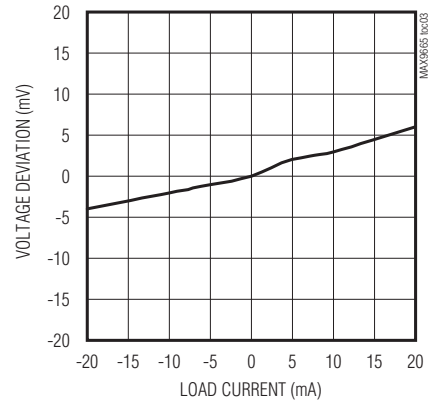

**INTEGRAL NONLINEARITY
vs. DAC CODE**

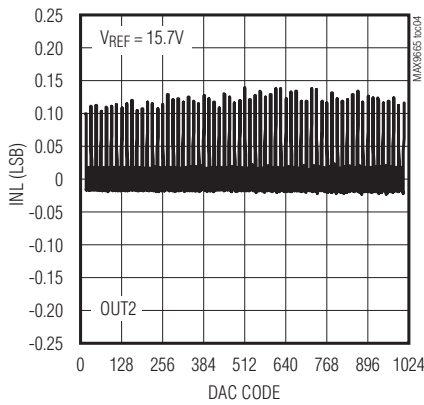

**INTEGRAL NONLINEARITY
vs. DAC CODE**

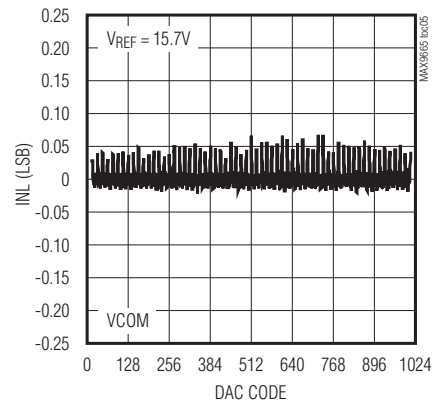

**INTEGRAL NONLINEARITY
vs. DAC CODE**

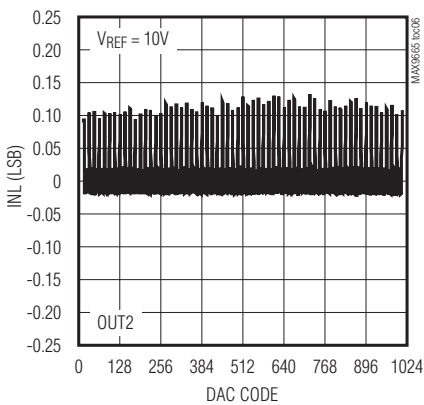

**INTEGRAL NONLINEARITY
vs. DAC CODE**

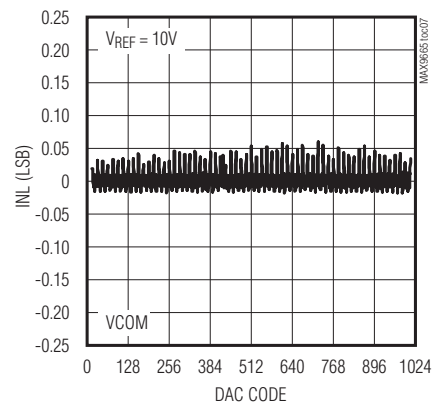

6/8/10-Channel, 10-Bit, Nonvolatile Programmable Gamma and VCOM Reference Voltages

Typical Operating Characteristics (continued)

($V_{AVDD} = V_{REF} = 15.7V$, $V_{DVDD} = 3.3V$, $V_{GND} = 0V$, VCOM connected to FB, CTL = DVDD/2, no load, $T_A = -40^{\circ}C$ to $+85^{\circ}C$, unless otherwise noted. Typical values are at $T_A = +25^{\circ}C$.) (Note 2)

MAX9665/MAX9666/MAX9667

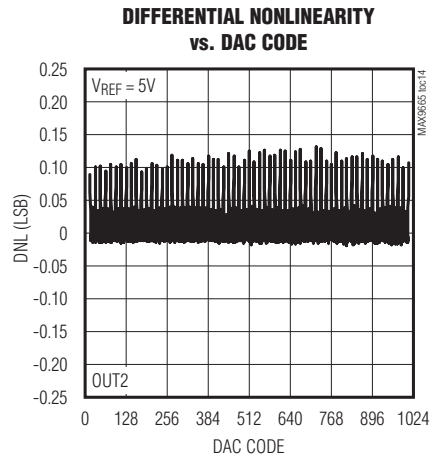
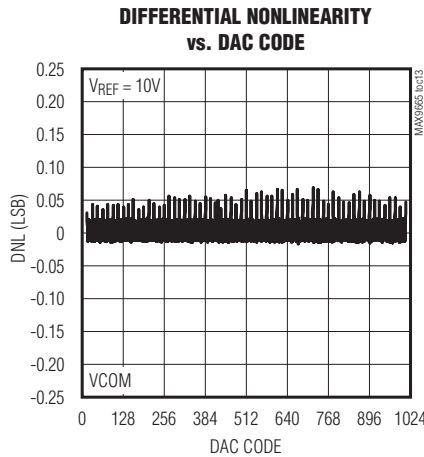
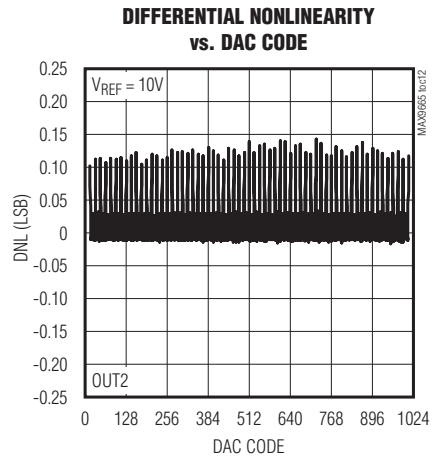
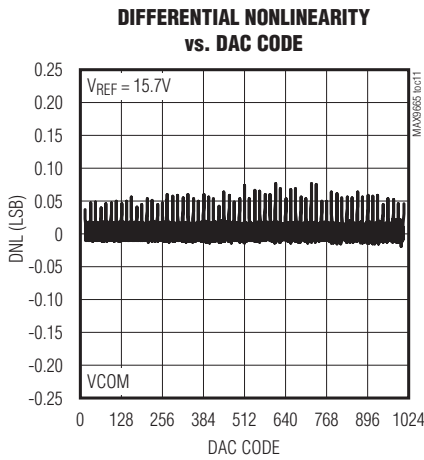
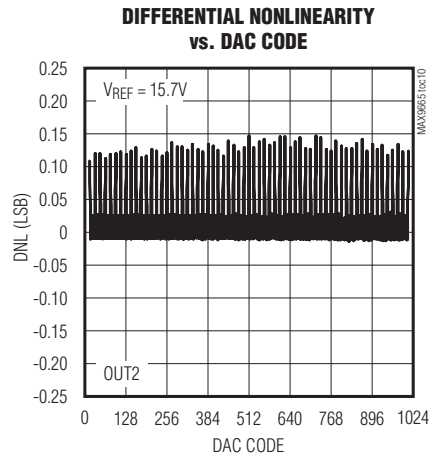
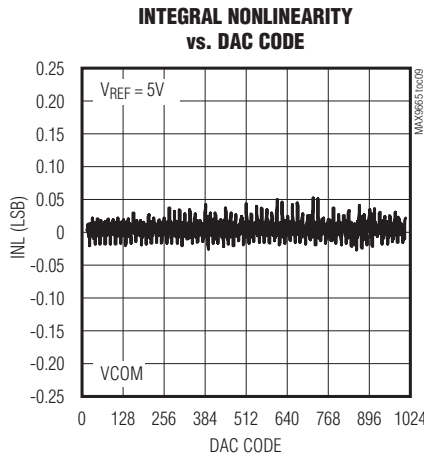
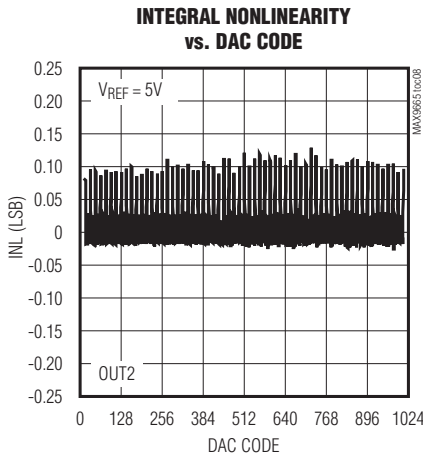

6/8/10-Channel, 10-Bit, Nonvolatile Programmable Gamma and VCOM Reference Voltages

Typical Operating Characteristics (continued)

($V_{AVDD} = V_{REF} = 15.7V$, $V_{DVDD} = 3.3V$, $V_{GND} = 0V$, VCOM connected to FB, CTL = DVDD/2, no load, $T_A = -40^{\circ}C$ to $+85^{\circ}C$, unless otherwise noted. Typical values are at $T_A = +25^{\circ}C$.) (Note 2)

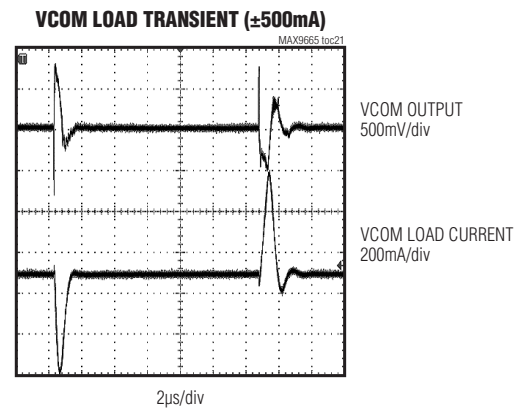
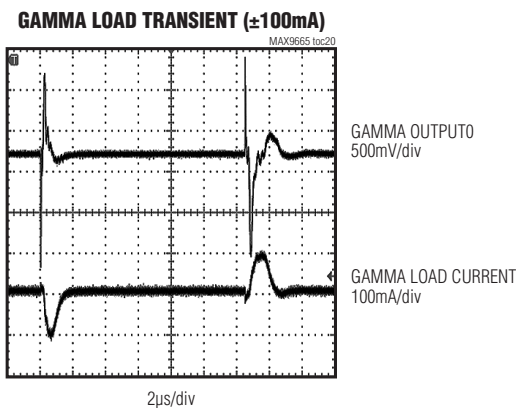
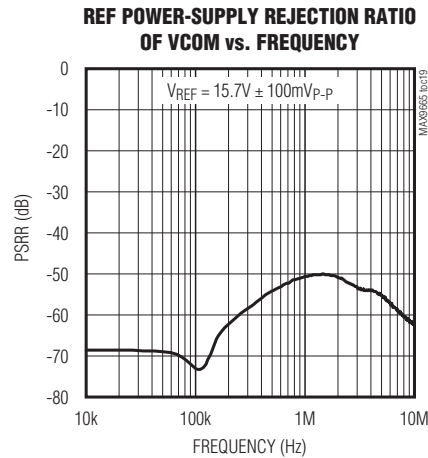
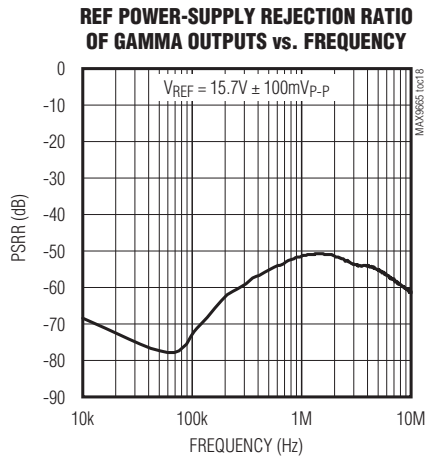
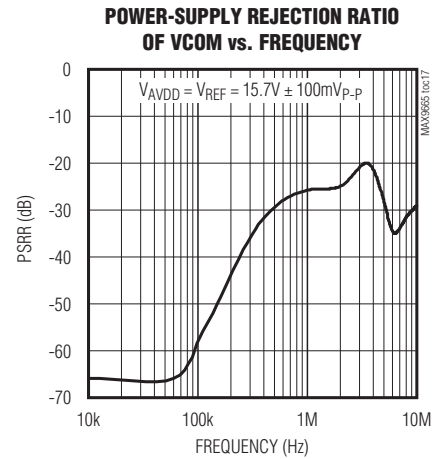
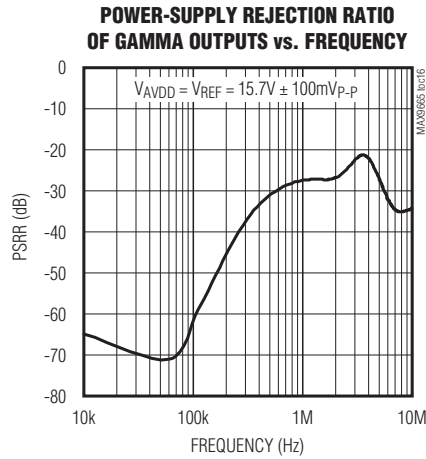
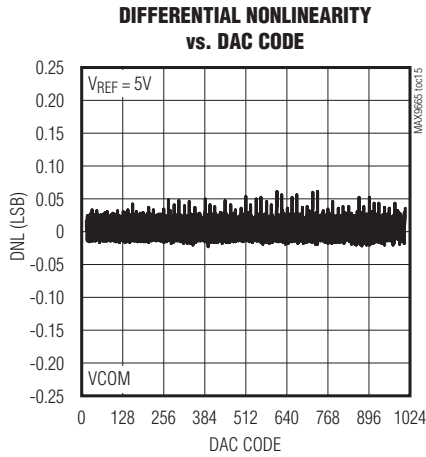

6/8/10-Channel, 10-Bit, Nonvolatile Programmable Gamma and VCOM Reference Voltages

Pin Description

PIN			NAME	FUNCTION
MAX9665	MAX9666	MAX9667		
1	1	1	CE	Single-Wire Control Interface Enable. Connect CE to DVDD to enable the CTL input. Connect CE to GND to disable the CTL input and reduce the supply current.
2	2	2	DVDD	Digital Supply Input. Bypass to GND with 0.1µF capacitor.
3	3	3	SCL	I ² C Serial-Clock Input
4	4	4	SDA	I ² C Serial-Data Input/Output
5	5	5	GND	Ground
—	—	6	OUT9	Gamma Output 9
—	—	7	OUT8	Gamma Output 8
—	6	8	OUT7	Gamma Output 7
—	7	9	OUT6	Gamma Output 6
6	8	10	OUT5	Gamma Output 5
8	10	11	OUT4	Gamma Output 4
10	11	12	OUT3	Gamma Output 3
11	13	13	OUT2	Gamma Output 2
13	14	14	OUT1	Gamma Output 1
15	15	15	OUT0	Gamma Output 0
16	16	16	REF	Reference Input
17	17	17	AVDD	Analog Supply Input. Bypass AVDD to GND with a minimum 0.1µF capacitor.
18	18	18	FB	VCOM Amplifier Negative Input
19	19	19	VCOM	VCOM Amplifier Output
20	20	20	CTL	VCOM Adjustment and Multiple-Time Programmable Memory Control. CTL sets the internal DAC code and programs the MTP memory. A pulse-control method is used to adjust the VCOM level. See the <i>VCOM Adjustment (CTL)</i> section. To program the DAC setting into the MTP memory as the power-on default, drive CTL to the MTP programming voltage using the correct timing and voltage ramp rates. See the <i>MTP Programming (CTL)</i> section.
7, 9, 12, 14	9, 12	—	N.C.	No Connection. Not internally connected.
—	—	—	EP	Exposed Pad. The exposed pad must be connected to GND.

MAX9665/MAX9666/MAX9667

6/8/10-Channel, 10-Bit, Nonvolatile Programmable Gamma and VCOM Reference Voltages

Detailed Description

The MAX9665/MAX9666/MAX9667 are a family of multi-channel, programmable reference voltages. Each channel has a 10-bit DAC to create the reference voltage. One channel has an operational amplifier that follows the DAC while all other channels have a buffer after the DAC. The user can program the DAC codes into on-chip nonvolatile memory, which is called multiple-time programmable (MTP) memory since data can be written into it up to 300 times.

The MAX9665/MAX9666/MAX9667 provide the gamma, VCOM, and level shifter reference voltages in a LCD panel. A single chip can potentially replace a discrete digital variable resistor (DVR), VCOM amplifier, gamma buffers, high-voltage linear regulator, and resistor strings. The high-voltage linear regulator can be eliminated because the DAC contains a lowpass filter that reduces horizontal line frequency noise by 40dB. Power sequencing is well-controlled since a single chip generates all the various reference voltages needed for the LCD panel.

Each part has an I²C interface for programming both the MTP memory and the I²C registers. For compatibility with legacy flicker adjustment production equipment, these devices include a single-wire interface that is compatible with the MAX1512.

With the MTP memory and the I²C interface, these devices enable automatic gamma and flicker calibration on a panel-by-panel basis on the production line. Contact your Maxim representative for more details.

10-Bit Digital-to-Analog Converters

The reference input, REF, accepts a DC voltage between ground (GND) and the analog supply voltage (AVDD). The voltage at REF sets the full-scale output of the DACs. Determine the output voltage using the following equations:

$$V_{OUT} = (V_{REF} \times CODE) / 2^N$$

where CODE is the numeric value of the DAC's binary input code and N is the bits of resolution. For the MAX9665 family, N = 10 and CODE ranges from 0 to 1023.

Note that even if REF is less than AVDD, the DAC can never output REF because the maximum value of CODE is always one LSB less than the reference. For example, if REF = 16V and CODE = 1023, then the output voltage is:

$$\begin{aligned} V_{OUT} &= (16V \times 1023) / 2^{10} \\ &= 15.98438V \end{aligned}$$

Gamma Buffers

There are two types of DAC output buffers: 5mA and 10mA. The 5mA buffer is guaranteed to source or sink 5mA of DC current within 0.2V of the supplies, and the 10mA buffer does the same with 10mA. The 10mA buffers should be attached to the ends of the resistor ladders that set the transfer function of the source driver (look at the connections from OUT0, OUT4, OUT5, and OUT9 on the typical operating circuit of the MAX9667). The 5mA buffers should be attached to the middle tap points of the resistor ladder because those places require less current than the ends (see the connections from OUT1, OUT2, OUT7, and OUT8 on the typical operating circuit of the MAX9667).

If the 10mA buffers cannot provide enough current to drive the ends of the resistor ladders, attach an additional resistor from the nearest supply. For example, at the very top of the resistor ladder, attach an additional resistor to AVDD. At the very bottom of the resistor ladder, attach an additional resistor to GND. The MAX9665/MAX9666/MAX9667 greatly diminish any noise from the AVDD supply through the discrete resistor because the high-frequency noise from REF has been attenuated, and the buffers have excellent AC PSRR. See Figure 1.

The source drivers can kick back a great deal of current to the buffer outputs during a horizontal line change or a polarity switch. The 5mA DAC output buffers can source/sink 200mA of peak transient current, and the 10mA DAC output buffers can source/sink 400mA of peak transient current to reduce the recovery time of the output voltages when critical levels and patterns are displayed.

VCOM Amplifier

The operational amplifier attached to the bottom DAC holds the VCOM voltage stable while providing the ability to source and sink 400mA into the backplane of a TFT-LCD panel. The operational amplifier can directly drive the capacitive load of the TFT-LCD backplane without the need for a series resistor in most cases. The VCOM amplifier has current limiting on its output to protect its bond wires.

The output (VCOM) and negative input (FB) of the operational amplifier are typically connected together in a unity-gain configuration. If higher output current is required, add an npn emitter follower and a pnp emitter follower in the feedback loop.

If a higher, closed-loop gain is desired, add feedback resistors as shown in Figure 2.

6/8/10-Channel, 10-Bit, Nonvolatile Programmable Gamma and VCOM Reference Voltages

MAX9665/MAX9666/MAX9667

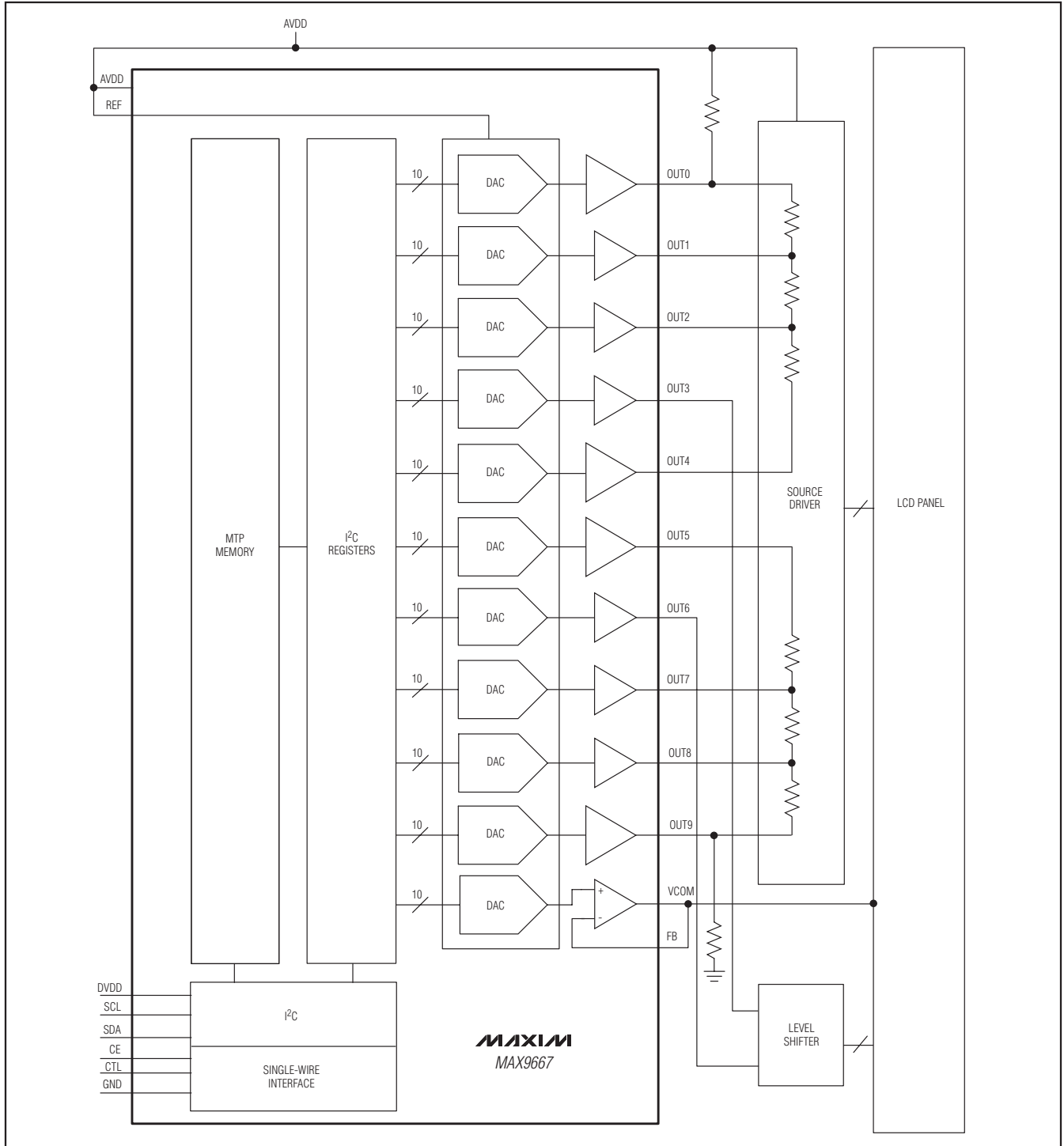

Figure 1. Pullup and Pulldown Resistors Attached to Source Driver

6/8/10-Channel, 10-Bit, Nonvolatile Programmable Gamma and VCOM Reference Voltages

Multiple-Time Programmable (MTP) Memory

MTP memory, which is a form of nonvolatile memory, stores the DAC code values even when the chip is not powered. When the chip is powered up, the code values are automatically transferred from MTP memory to the I²C registers. See the *Power-On Reset (POR)/Power-Up* section for more details.

The user can program DAC codes into MTP memory for up to 300 times. In conventional TFT-LCD applications, a resistor string creates the gamma voltages. MTP memory eliminates the resistor string and the need to change manually the resistor values when searching for the optimal gamma curve for a new TFT-LCD panel model.

Power-On Reset (POR)/Power-Up

The POR circuit that monitors DVDD ensures that all I²C registers are reset to their MTP values upon power-up or POR. Once DVDD rises above 2.4V (typ), the POR circuit releases the I²C registers and the values stored in MTP are loaded. Should DVDD drop to less than 2.4V typical, then the contents of the registers can no longer be guaranteed and a reset is generated. When DVDD rises back above the POR voltage, the values stored in MTP are loaded back into the I²C registers.

The transfer time of the MTP registers to I²C registers is 300µs typical and is less than 400µs in the worst case. During this time, AVDD should not be powered up, and the I²C does not acknowledge any commands (the I²C only starts acknowledging commands after all registers have been loaded from MTP).

Thermal Protection

When the die temperature reaches +165°C, all gamma buffers except for the middle ones are disabled. See Table 1.

When the die cools down by 15°C, all the buffers are enabled again.

The VCOM operational amplifier does not have thermal protection.

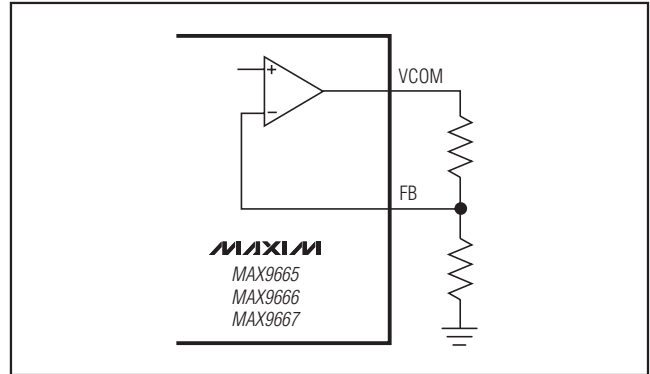

Figure 2. VCOM Operational Amplifier with Feedback Resistors

Digital Interfaces

The MAX9665/MAX9666/MAX9667 have two digital interfaces: I²C and single-wire. Through the I²C interface, the user can change all the registers and program MTP memory. The I²C interface is the more general purpose of the two interfaces.

The single-wire interface, which is compatible with the MAX1512 digital interface, is included to support TFT-LCD production lines that depend upon the single-wire interface to adjust the VCOM voltage to minimize flicker. Note that the single-wire interface cannot program the gamma registers or gamma MTP memory.

Interoperability Between the Single-Wire Interface and the I²C Interface

To prevent any collision between the single-wire interface and the I²C interface, operation through one interface is only allowed if the other is in the idle state. For example, if the I²C interface is in the middle of executing a command, any input through the single-wire interface is ignored. Conversely, if the single-wire interface is in the middle of executing a command, the I²C interface does not acknowledge any commands.

Table 1. Buffer Output Status During Thermal Shutdown

PART	ENABLED	DISABLED
MAX9665	OUT2 and OUT3	OUT0, OUT1, OUT4, OUT5
MAX9666	OUT3 and OUT4	OUT0, OUT1, OUT2, OUT5, OUT6, OUT7
MAX9667	OUT4 and OUT5	OUT0, OUT1, OUT2, OUT3, OUT6, OUT7, OUT8, OUT9

6/8/10-Channel, 10-Bit, Nonvolatile Programmable Gamma and VCOM Reference Voltages

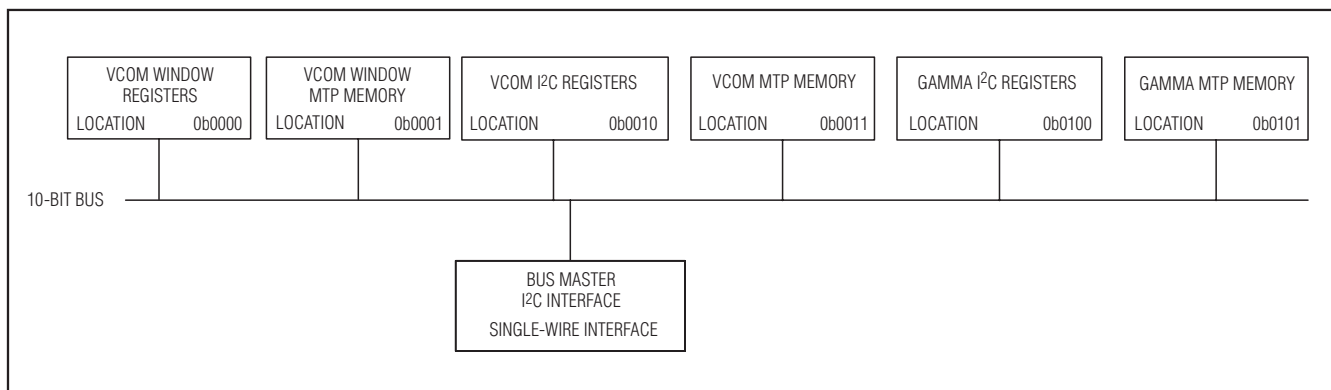

Figure 3. 10-Bit Bus

Bus Architecture

The internal memory, both volatile and nonvolatile, is divided into blocks that are connected by a 10-bit bus (Figure 3).

The I²C registers (volatile memory) are 8 bits wide. Two I²C registers are needed to hold one 10-bit DAC code. The I²C registers are separated into blocks that are distinguished by whether they hold VCOM DAC codes or gamma DAC codes. MTP memory (nonvolatile memory) is organized in the same manner. The VCOM MTP memory has enough bits to store the single VCOM DAC code. Likewise, the gamma MTP memory has enough bits to store all of the gamma DAC codes. Each block connected to the 10-bit bus has a unique location number with one exception. The block that contains the bus master, I²C interface, and the single-wire interface does not store any data, and hence, it does not have a location number.

Although the external I²C interface transfers data in units of 8 bits (1 byte), the internal bus that connects the I²C registers, MTP memory, and digital interfaces is 10 bits wide because the DAC code size is 10 bits. The 10-bit bus can also accommodate data transfers of fewer than 10 bits since communication to the outside world is through either an 8-bit I²C interface or a 1-bit single-wire interface. Writing a single byte to any address location is ignored.

The 10-bit bus connects together registers, MTP memories, and digital interfaces. The bus master resides in the same block as the I²C interface and the single-wire interface.

VCOM MTP Programming

Through the I²C Interface

To program VCOM MTP memory, the I²C master must first write the DAC code that is to be stored into the VCOM I²C registers. Next, the I²C master must send a command to move the data in the VCOM I²C registers to the VCOM MTP memory, thereby finishing the programming.

To read VCOM MTP memory, the I²C master must issue a command to move the data in the VCOM MTP memory to the VCOM I²C registers. Then it can read the two VCOM I²C registers.

To program gamma MTP memory, the I²C master must first write the complete set of gamma DAC codes into the gamma I²C registers. For example, six gamma DAC codes must be written into the MAX9665 since it has six gamma outputs. Next, the I²C master must send a command to move the data in the gamma I²C registers to the gamma MTP memory.

To read gamma MTP memory, the I²C master must issue a command to move the data in the gamma MTP memory to the gamma I²C registers. Then it can read the gamma I²C registers.

During MTP programming, the parts do not respond to the I²C interface. The part generates an acknowledge to the MTP programming command, but the I²C interface does not generate further acknowledge signals until MTP programming is complete.

If the analog supply voltage is not greater than the minimum required for MTP programming, the I²C still acknowledges the MTP write command, but MTP programming is disabled. The I²C continues to acknowledge and process non-MTP write commands.

See the *Register Description* section for further explanation on how to execute commands.

6/8/10-Channel, 10-Bit, Nonvolatile Programmable Gamma and VCOM Reference Voltages

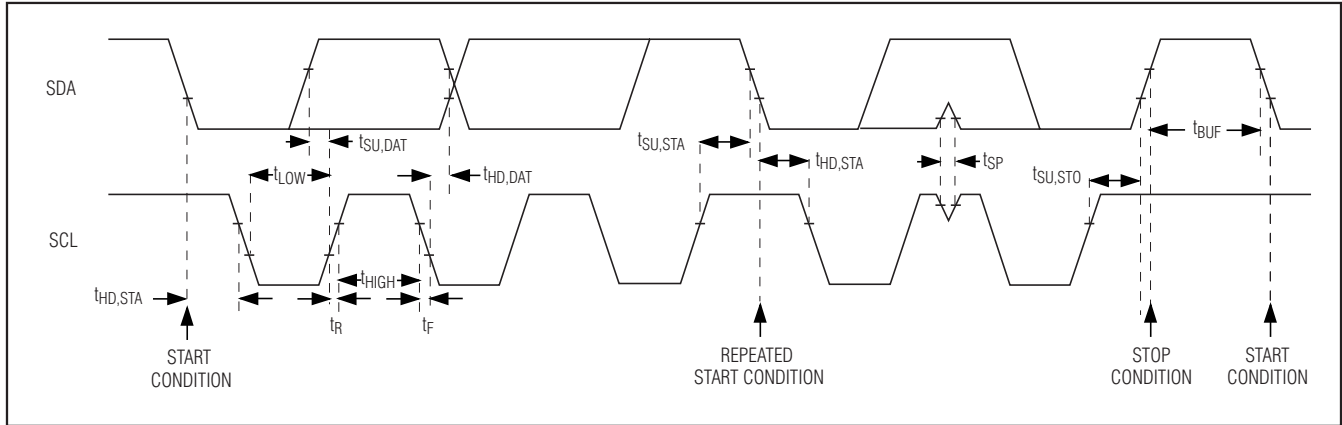

Figure 4. I²C Serial-Interface Timing Diagram

Through the Single-Wire Interface

For VCOM MTP programming through the single-wire interface, see the *Single-Wire Interface* section.

VCOM Programming Range

Two registers, VCOMMIN and VCOMMAX, are provided to set the minimum and maximum VCOM register value. These two registers are accessed through the I²C interface and can be written to and read from MTP memory. If any adjustment, either through I²C or the single-wire interface takes the VCOM register value less than VCOMMIN, then the value in VCOMMIN is stored in the VCOM register. Similarly, if any adjustment, either through I²C or the single-wire interface takes the VCOM register value greater than VCOMMAX, then the value in VCOMMAX is stored in the VCOM register.

I²C Interface

The MAX9665/MAX9666/MAX9667 feature an I²C/SMBus™-compatible, 2-wire serial interface consisting of a serial-data line (SDA) and a serial-clock line (SCL). SDA and SCL facilitate communication between the devices and the master at clock rates up to 400kHz. Figure 4 shows the 2-wire interface timing diagram. The master generates SCL and initiates data transfer on the bus. A master device writes data to the devices by transmitting the proper slave address followed by the register address and then the data word. Each transmit sequence is framed by a START (S) or REPEATED START (Sr) condition and a STOP (P) condition. Each word transmitted to the MAX9665/MAX9666/MAX9667 is 8 bits long and followed by an acknowledge clock pulse. A master reading data from the devices transmits the proper slave address followed by a series of nine SCL pulses. The devices transmit data on SDA in sync with the master-generated SCL pulses. The master

SMBus is a trademark of Intel Corp.

acknowledges receipt of each byte of data. Each read sequence is framed by a START or REPEATED START condition, a not acknowledge, and a STOP condition. SDA operates as both an input and an open-drain output. A pullup resistor, typically greater than 500Ω, is required on the SDA bus. SCL operates as only an input. A pullup resistor, typically greater than 500Ω, is required on SCL if there are multiple masters on the bus, or if the master in a single-master system has an open-drain SCL output. Series resistors in line with SDA and SCL are optional. Series resistors protect the digital inputs of the devices from high-voltage spikes on the bus lines, and minimize crosstalk and undershoot of the bus signals.

Bit Transfer

One data bit is transferred during each SCL cycle. The data on SDA must remain stable during the high period of the SCL pulse. Changes in SDA while SCL is high are control signals (see the *START and STOP Conditions* section). SDA and SCL idle high when the I²C bus is not busy.

START and STOP Conditions

SDA and SCL idle high when the bus is not in use. A master initiates communication by issuing a START condition. A START condition is a high-to-low transition on SDA with SCL high. A STOP condition is a low-to-high transition on SDA while SCL is high (Figure 5). A START condition from the master signals the beginning of a transmission to the MAX9665/MAX9666/MAX9667. The master terminates transmission, and frees the bus, by issuing a STOP condition. The bus remains active if a REPEATED START condition is generated instead of a STOP condition.

6/8/10-Channel, 10-Bit, Nonvolatile Programmable Gamma and VCOM Reference Voltages

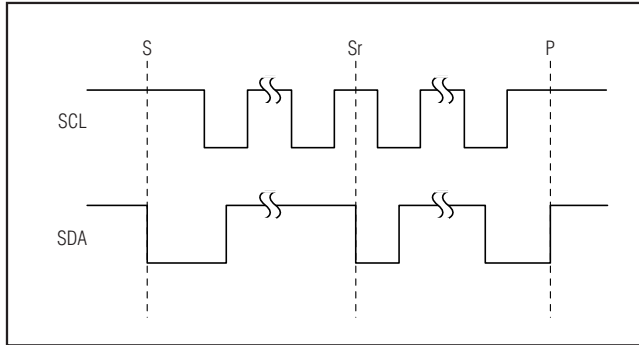

Figure 5. START, STOP, and REPEATED START Conditions

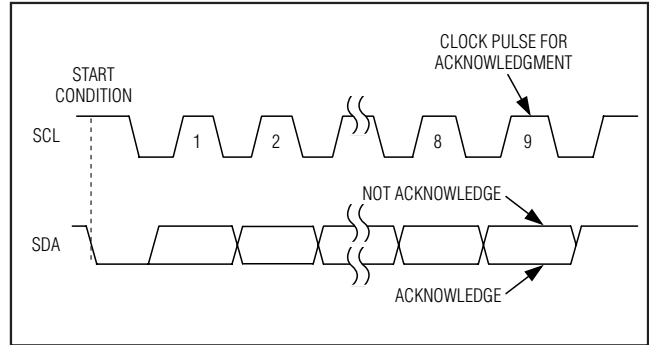

Figure 6. Acknowledge

Early STOP Conditions

The MAX9665/MAX9666/MAX9667 recognize a STOP condition at any point during data transmission except if the STOP condition occurs in the same high pulse as a START condition. For proper operation, do not send a STOP condition during the same SCL high pulse as the START condition.

Slave Address

The slave address is defined as the 7 most significant bits (MSBs) followed by the read/write (R/\bar{W}) bit. Set the R/\bar{W} bit to 1 to configure the MAX9665/MAX9666/MAX9667 to read mode. Set the R/\bar{W} bit to 0 to configure the MAX9665/MAX9666/MAX9667 to write mode. The address is the first byte of information sent to the MAX9665/MAX9666/MAX9667 after the START condition. The MAX9665/MAX9666/MAX9667 slave address is 0x9E for writing and 0x9F for reading.

Acknowledge

The acknowledge bit (ACK) is a clocked 9th bit that the MAX9665/MAX9666/MAX9667 use to handshake receipt of each byte of data when in write mode (see Figure 6). The MAX9665/MAX9666/MAX9667 pull down SDA during the entire master-generated ninth clock pulse if the previous byte is successfully received. Monitoring ACK allows for detection of unsuccessful data transfers. An unsuccessful data transfer occurs if a receiving device is busy or if a system fault has occurred. In the event of an unsuccessful data transfer, the bus master may retry communication. The master pulls down SDA during the ninth clock cycle to acknowledge receipt of data when the MAX9665/MAX9666/MAX9667 are in read mode. An acknowledge is sent by the master after each read byte to allow data transfer to continue. A not acknowledge is sent when the master reads the final byte of data from the MAX9665/MAX9666/MAX9667, followed by a STOP condition.

Table 2. Slave ID Description

B7	B6	B5	B4	B3	B2	B1	B0	WRITE ADDRESS (hex)	READ ADDRESS (hex)
1	0	0	1	1	1	1	R/\bar{W}	0x9E	0x9F

6/8/10-Channel, 10-Bit, Nonvolatile Programmable Gamma and VCOM Reference Voltages

Write Data Format

A write to the MAX9665/MAX9666/MAX9667 consists of transmitting a START condition, the slave address with the R/W bit set to 0, one data byte of data to configure the internal register address pointer, one or more data bytes, and a STOP condition. Figure 7 illustrates the frame format for writing one byte of data to the MAX9665/MAX9666/MAX9667.

The slave address with the R/W bit set to 0 indicates that the master intends to write data to the MAX9665/MAX9666/MAX9667. The MAX9665/MAX9666/MAX9667 acknowledge receipt of the address byte during the master-generated ninth SCL pulse.

The second byte transmitted from the master configures the MAX9665/MAX9666/MAX9667's internal register address pointer. The pointer tells the MAX9665/MAX9666/MAX9667 where to write the next byte of data. An acknowledge pulse is sent by the MAX9665/MAX9666/MAX9667 upon receipt of the address pointer data.

The third byte sent to the MAX9665/MAX9666/MAX9667 contains the data that is written to the chosen register. An acknowledge pulse from the MAX9665/MAX9666/MAX9667 signals receipt of the data byte. The address pointer autoincrements to the next register address after each received data byte. This autoincrement feature allows a master to write to sequential register address locations within one continuous frame. The master signals the end of transmission by issuing a STOP condition.

Read Data Format

The master presets the address pointer by first sending the MAX9665/MAX9666/MAX9667's slave address with the R/W bit set to 0 followed by the register address after a START condition. The MAX9665/MAX9666/MAX9667 acknowledge receipt of the slave address and the register address by pulling SDA low during the ninth SCL clock pulse. A REPEATED START condition is then sent followed by the slave address with the R/W bit set to 1. The MAX9665/MAX9666/MAX9667 transmit the contents of the specified register. Transmitted data is valid on the rising edge of the master-generated serial clock (SCL). The address pointer autoincrements after each read data byte. This autoincrement feature allows all registers to be read sequentially within one continuous frame. A STOP condition can be issued after any number of read data bytes. If a STOP condition is issued followed by another read operation, the first data byte to be read is from the register address location set by the previous transaction and not 0x00 and subsequent reads autoincrement the address pointer until the next STOP condition. Attempting to read from register addresses higher than the highest valid address locations (0x13 for MAX9665, 0x17 for MAX9666, 0x1B for MAX9667) in repeated reads from a dummy register containing all one data. The master acknowledges receipt of each read byte during the acknowledge clock pulse. The master must acknowledge all correctly received bytes except the last byte. The final byte must be followed by a not acknowledge from the master and then a STOP condition. Figures 8 and 9 illustrate the frame format for reading data from the MAX9665/MAX9666/MAX9667.

6/8/10-Channel, 10-Bit, Nonvolatile Programmable Gamma and VCOM Reference Voltages

MAX9665/MAX9666/MAX9667

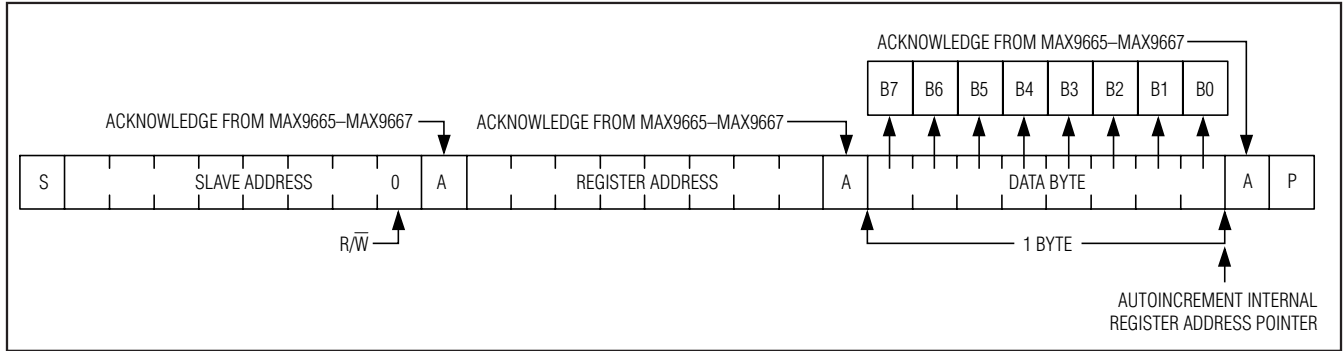

Figure 7. Writing One Byte of Data to the MAX9665/MAX9666/MAX9667

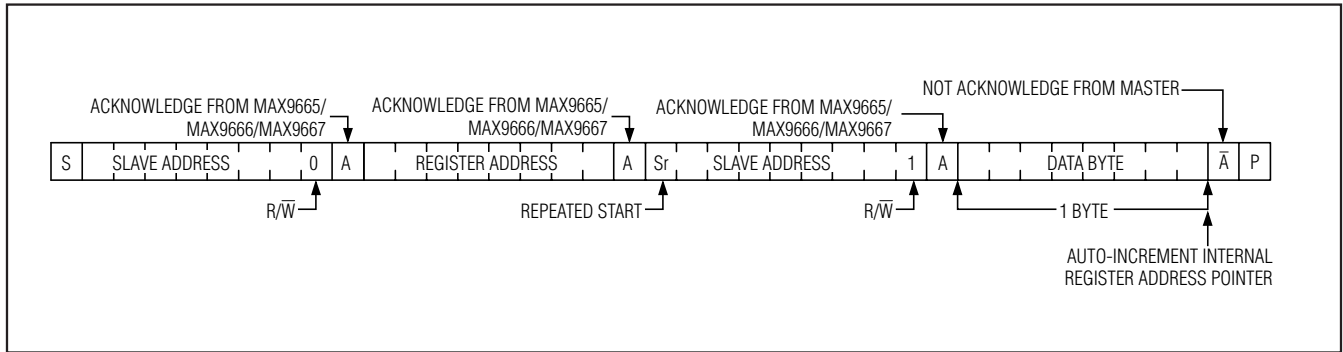

Figure 8. Reading One Indexed Byte of Data from the MAX9665/MAX9666/MAX9667

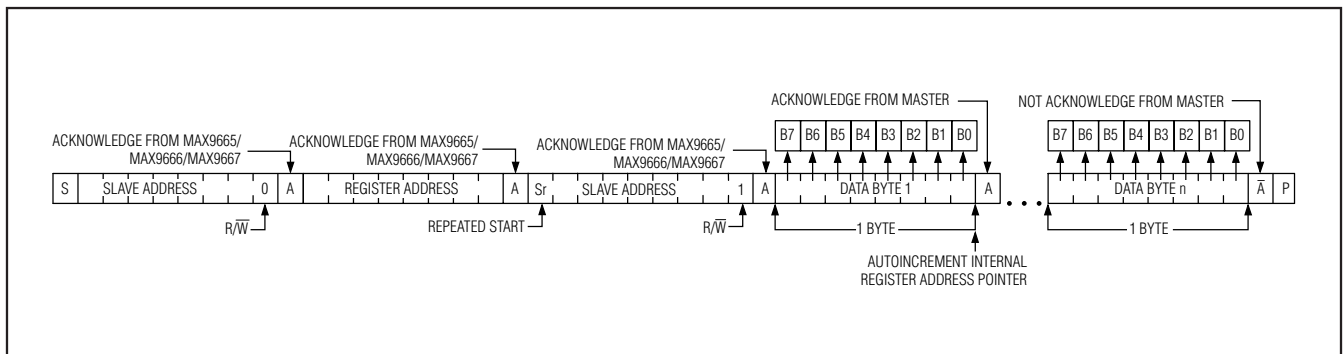

Figure 9. Reading n Bytes of Indexed Data from the MAX9665/MAX9666/MAX9667

6/8/10-Channel, 10-Bit, Nonvolatile Programmable Gamma and VCOM Reference Voltages

Register Map

The I²C interface was architected for 8-bit systems. With the increase in DAC resolution from 8 bits to 10 bits, 2 bytes must be transferred to get 10 bits. Therefore, the word size is 2 bytes (16 bits) in the register map. Byte order is big endian. The least significant

byte (LSB) holds the bottom 8 bits of the 10-bit data, while the most significant byte (MSB) holds the top 2 bits of the 10-bit data. The I²C stores each 10-bit DAC code in two 8-bit registers, as shown in the register maps of Tables 3, 4, and 5.

Table 3. Register Map for MAX9665

LEAST SIGNIFICANT BYTE		MOST SIGNIFICANT BYTE		COMMENTS
REGISTER ADDRESS	REGISTER NAME	REGISTER ADDRESS	REGISTER NAME	
0x01	CMD_OPND	0x00	CMD_OPRN	Command
0x03	VCOMMIN_L	0x02	VCOMMIN_M	VCOM (minimum)
0x05	VCOMMAX_L	0x04	VCOMMAX_M	VCOM (maximum)
0x07	VCOM_L	0x06	VCOM_M	VCOM
0x09	GMA0_L	0x08	GMA0_M	Gamma 0
0x0B	GMA1_L	0x0A	GMA1_M	Gamma 1
0x0D	GMA2_L	0x0C	GMA2_M	Gamma 2
0x0F	GMA3_L	0x0E	GMA3_M	Gamma 3
0x11	GMA4_L	0x10	GMA4_M	Gamma 4
0x13	GMA5_L	0x12	GMA5_M	Gamma 5

Table 4. Register Map for MAX9666

LEAST SIGNIFICANT BYTE		MOST SIGNIFICANT BYTE		COMMENTS
REGISTER ADDRESS	REGISTER NAME	REGISTER ADDRESS	REGISTER NAME	
0x01	CMD_OPND	0x00	CMD_OPRN	Command
0x03	VCOMMIN_L	0x02	VCOMMIN_M	VCOM (minimum)
0x05	VCOMMAX_L	0x04	VCOMMAX_M	VCOM (maximum)
0x07	VCOM_L	0x06	VCOM_M	VCOM
0x09	GMA0_L	0x08	GMA0_M	Gamma 0
0x0B	GMA1_L	0x0A	GMA1_M	Gamma 1
0x0D	GMA2_L	0x0C	GMA2_M	Gamma 2
0x0F	GMA3_L	0x0E	GMA3_M	Gamma 3
0x11	GMA4_L	0x10	GMA4_M	Gamma 4
0x13	GMA5_L	0x12	GMA5_M	Gamma 5
0x15	GMA6_L	0x14	GMA6_M	Gamma 6
0x17	GMA7_L	0x16	GMA7_M	Gamma 7

6/8/10-Channel, 10-Bit, Nonvolatile Programmable Gamma and VCOM Reference Voltages

Table 5. Register Map for MAX9667

LEAST SIGNIFICANT BYTE		MOST SIGNIFICANT BYTE		COMMENTS
REGISTER ADDRESS	REGISTER NAME	REGISTER ADDRESS	REGISTER NAME	
0x01	CMD_OPND	0x00	CMD_OPRN	Command
0x03	VCOMMIN_L	0x02	VCOMMIN_M	VCOM (minimum)
0x05	VCOMMAX_L	0x04	VCOMMAX_M	VCOM (maximum)
0x07	VCOM_L	0x06	VCOM_M	VCOM
0x09	GMA0_L	0x08	GMA0_M	Gamma 0
0x0B	GMA1_L	0x0A	GMA1_M	Gamma 1
0x0D	GMA2_L	0x0C	GMA2_M	Gamma 2
0x0F	GMA3_L	0x0E	GMA3_M	Gamma 3
0x11	GMA4_L	0x10	GMA4_M	Gamma 4
0x13	GMA5_L	0x12	GMA5_M	Gamma 5
0x15	GMA6_L	0x14	GMA6_M	Gamma 6
0x17	GMA7_L	0x16	GMA7_M	Gamma 7
0x19	GMA8_L	0x18	GMA8_M	Gamma 8
0x1B	GMA9_L	0x1A	GMA9_M	Gamma 9

Register Description

The I²C registers either hold DAC codes or commands (see Tables 6, 7, and 8). After power-up, the digital circuitry loads the values stored in MTP memory into the VCOM and gamma registers. This process takes approximately 350 μ s. During this time, the I²C does not respond to any commands (either from the user or from the single-wire interface). To ensure the gamma chip does not reverse bias, the source driver, the VCOM DAC code, and the gamma DAC codes upon power-up are as shown in the Tables 6, 7, and 8.

The I²C master can write a command such as MOV (move) into a pair of command registers. To execute a valid command, the command operation (CMD_OPRN) and command operand (CMD_OPND) registers must be written to sequentially in the same I²C transaction (between the same I²C start/stop).

The form of the command is shown below:

Operation	Operands
-----------	----------

To move data from gamma registers to gamma MTP memory, use the following command (essentially, data is being written into MTP memory):

MOV	MOV Gamma Registers	Gamma MTP
-----	---------------------	-----------

MOV is the operation. Gamma registers and gamma MTP memory are operands. Both the operation and the operands must be assembled into machine code that is written into the command registers. The machine code for the operation must be written into the command operation register (CMD_OPRN). The machine code for the operands (if there are any) must be written into command operand register (CMD_OPND). Table 9 shows the list of operations and operands.

6/8/10-Channel, 10-Bit, Nonvolatile Programmable Gamma and VCOM Reference Voltages

Table 6. MAX9665 Register Description

REGISTER ADDRESS	REGISTER NAME	REGISTER DESCRIPTION	BIT								POWER-ON RESET VALUE	MTP FACTORY INITIALIZATION VALUE	READ AND WRITE?
			7	6	5	4	3	2	1	0			
0x00	CMD_OPRN	Command operation	d7	d6	d5	d4	d3	d2	d1	d0	0x00	Not applicable	Write only
0x01	CMD_OPND	Command operand	d7	d6	d5	d4	d3	d2	d1	d0	0x00	Not applicable	Write only
0x02	VCOMMIN_M	VCOMMIN (most significant byte)	x	x	x	x	x	x	d9	d8	0x00	0x00	Read and write
0x03	VCOMMIN_L	VCOMMIN (least significant byte)	d7	d6	d5	d4	d3	d2	d1	d0	0x00	0x00	Read and write
0x04	VCOMMAX_M	VCOMMAX (most significant byte)	x	x	x	x	x	x	d9	d8	0x03	0x03	Read and write
0x05	VCOMMAX_L	VCOMMAX (least significant byte)	d7	d6	d5	d4	d3	d2	d1	d0	0xFF	0xFF	Read and write
0x06	VCOM_M	VCOM (most significant byte)	x	x	x	x	x	x	d9	d8	0x02	0x02	Read and write
0x07	VCOM_L	VCOM (least significant byte)	d7	d6	d5	d4	d3	d2	d1	d0	0x00	0x00	Read and write
0x08	GMA0_M	Gamma 0 (most significant byte)	x	x	x	x	x	x	d9	d8	0x03	0x03	Read and write
0x09	GMA0_L	Gamma 0 (least significant byte)	d7	d6	d5	d4	d3	d2	d1	d0	0x80	0x80	Read and write
0x0A	GMA1_M	Gamma 1 (most significant byte)	x	x	x	x	x	x	d9	d8	0x03	0x03	Read and write
0x0B	GMA1_L	Gamma 1 (least significant byte)	d7	d6	d5	d4	d3	d2	d1	d0	0x00	0x00	Read and write
0x0C	GMA2_M	Gamma 2 (most significant byte)	x	x	x	x	x	x	d9	d8	0x02	0x02	Read and write

Note: d0, d1, d2, d3, d4, d5, d6, d7, d8, d9 = valid data bits; x = don't care.

6/8/10-Channel, 10-Bit, Nonvolatile Programmable Gamma and VCOM Reference Voltages

MAX9665/MAX9666/MAX9667

Table 6. MAX9665 Register Description (continued)

REGISTER ADDRESS	REGISTER NAME	REGISTER DESCRIPTION	BIT								POWER-ON RESET VALUE	MTP FACTORY INITIALIZATION VALUE	READ AND WRITE?
			7	6	5	4	3	2	1	0			
0x0D	GMA2_L	Gamma 2 (least significant byte)	d7	d6	d5	d4	d3	d2	d1	d0	0x80	0x80	Read and write
0x0E	GMA3_M	Gamma 3 (most significant byte)	x	x	x	x	x	x	d9	d8	0x01	0x01	Read and write
0x0F	GMA3_L	Gamma 3 (least significant byte)	d7	d6	d5	d4	d3	d2	d1	d0	0x80	0x80	Read and write
0x10	GMA4_M	Gamma 4 (most significant byte)	x	x	x	x	x	x	d9	d8	0x01	0x01	Read and write
0x11	GMA4_L	Gamma 4 (least significant byte)	d7	d6	d5	d4	d3	d2	d1	d0	0x00	0x00	Read and write
0x12	GMA5_M	Gamma 5 (most significant byte)	x	x	x	x	x	x	d9	d8	0x00	0x00	Read and write
0x13	GMA5_L	Gamma 5 (least significant byte)	d7	d6	d5	d4	d3	d2	d1	d0	0x80	0x80	Read and write

Note: d0, d1, d2, d3, d4, d5, d6, d7, d8, d9 = valid data bits; x = don't care.

6/8/10-Channel, 10-Bit, Nonvolatile Programmable Gamma and VCOM Reference Voltages

Table 7. MAX9666 Register Description

REGISTER ADDRESS	REGISTER NAME	REGISTER DESCRIPTION	BIT								POWER-ON RESET VALUE	MTP FACTORY INITIALIZATION VALUE	READ AND WRITE?
			7	6	5	4	3	2	1	0			
0x00	CMD_OPRN	Command operation	d7	d6	d5	d4	d3	d2	d1	d0	0x00	Not applicable	Write only
0x01	CMD_OPND	Command operand	d7	d6	d5	d4	d3	d2	d1	d0	0x00	Not applicable	Write only
0x02	VCOMMIN_M	VCOMMIN (most significant byte)	x	x	x	x	x	x	d9	d8	0x00	0x00	Read and write
0x03	VCOMMIN_L	VCOMMIN (least significant byte)	d7	d6	d5	d4	d3	d2	d1	d0	0x00	0x00	Read and write
0x04	VCOMMAX_M	VCOMMAX (most significant byte)	x	x	x	x	x	x	d9	d8	0x03	0x03	Read and write
0x05	VCOMMAX_L	VCOMMAX (least significant byte)	d7	d6	d5	d4	d3	d2	d1	d0	0xFF	0xFF	Read and write
0x06	VCOM_M	VCOM (most significant byte)	x	x	x	x	x	x	d9	d8	0x02	0x02	Read and write
0x07	VCOM_L	VCOM (least significant byte)	d7	d6	d5	d4	d3	d2	d1	d0	0x00	0x00	Read and write
0x08	GMA0_M	Gamma 0 (most significant byte)	x	x	x	x	x	x	d9	d8	0x03	0x03	Read and write
0x09	GMA0_L	Gamma 0 (least significant byte)	d7	d6	d5	d4	d3	d2	d1	d0	0x80	0x80	Read and write

Note: d0, d1, d2, d3, d4, d5, d6, d7, d8, d9 = valid data bits; x = don't care.

6/8/10-Channel, 10-Bit, Nonvolatile Programmable Gamma and VCOM Reference Voltages

MAX9665/MAX9666/MAX9667

Table 7. MAX9666 Register Description (continued)

REGISTER ADDRESS	REGISTER NAME	REGISTER DESCRIPTION	BIT								POWER-ON RESET VALUE	MTP FACTORY INITIALIZATION VALUE	READ AND WRITE?	
			7	6	5	4	3	2	1	0				
0x0A	GMA1_M	Gamma 1 (most significant byte)	x	x	x	x	x	x	x	d9	d8	0x03	0x03	Read and write
0x0B	GMA1_L	Gamma 1 (least significant byte)	d7	d6	d5	d4	d3	d2	d1	d0		0x40	0x40	Read and write
0x0C	GMA2_M	Gamma 2 (most significant byte)	x	x	x	x	x	x	x	d9	d8	0x03	0x03	Read and write
0x0D	GMA2_L	Gamma 2 (least significant byte)	d7	d6	d5	d4	d3	d2	d1	d0		0x00	0x00	Read and write
0x0E	GMA3_M	Gamma 3 (most significant byte)	x	x	x	x	x	x	x	d9	d8	0x02	0x02	Read and write
0x0F	GMA3_L	Gamma 3 (least significant byte)	d7	d6	d5	d4	d3	d2	d1	d0		0x80	0x80	Read and write
0x10	GMA4_M	Gamma 4 (most significant byte)	x	x	x	x	x	x	x	d9	d8	0x01	0x01	Read and write
0x11	GMA4_L	Gamma 4 (least significant byte)	d7	d6	d5	d4	d3	d2	d1	d0		0x80	0x80	Read and write
0x12	GMA5_M	Gamma 5 (most significant byte)	x	x	x	x	x	x	x	d9	d8	0x01	0x01	Read and write

Note: d0, d1, d2, d3, d4, d5, d6, d7, d8, d9 = valid data bits; x = don't care.

6/8/10-Channel, 10-Bit, Nonvolatile Programmable Gamma and VCOM Reference Voltages

Table 7. MAX9666 Register Description (continued)

REGISTER ADDRESS	REGISTER NAME	REGISTER DESCRIPTION	BIT								POWER-ON RESET VALUE	MTP FACTORY INITIALIZATION VALUE	READ AND WRITE?
			7	6	5	4	3	2	1	0			
0x13	GMA5_L	Gamma 5 (least significant byte)	d7	d6	d5	d4	d3	d2	d1	d0	0x00	0x00	Read and write
0x14	GMA6_M	Gamma 6 (most significant byte)	x	x	x	x	x	x	d9	d8	0x00	0x00	Read and write
0x15	GMA6_L	Gamma 6 (least significant byte)	d7	d6	d5	d4	d3	d2	d1	d0	0xC0	0xC0	Read and write
0x16	GMA7_M	Gamma 7 (most significant byte)	x	x	x	x	x	x	d9	d8	0x00	0x00	Read and write
0x17	GMA7_L	Gamma 7 (least significant byte)	d7	d6	d5	d4	d3	d2	d1	d0	0x80	0x80	Read and write

Note: d0, d1, d2, d3, d4, d5, d6, d7, d8, d9 = valid data bits; x = don't care.

6/8/10-Channel, 10-Bit, Nonvolatile Programmable Gamma and VCOM Reference Voltages

MAX9665/MAX9666/MAX9667

Table 8. MAX9667 Register Description

REGISTER ADDRESS	REGISTER NAME	REGISTER DESCRIPTION	BIT								POWER-ON RESET VALUE	MTP FACTORY INITIALIZATION VALUE	READ AND WRITE?
			7	6	5	4	3	2	1	0			
0x00	CMD_OPRN	Command operation	d7	d6	d5	d4	d3	d2	d1	d0	0x00	Not applicable	Write only
0x01	CMD_OPND	Command operand	d7	d6	d5	d4	d3	d2	d1	d0	0x00	Not applicable	Write only
0x02	VCOMMIN_M	VCOMMIN (most significant byte)	x	x	x	x	x	x	d9	d8	0x00	0x00	Read and write
0x03	VCOMMIN_L	VCOMMIN (least significant byte)	d7	d6	d5	d4	d3	d2	d1	d0	0x00	0x00	Read and write
0x04	VCOMMAX_M	VCOMMAX (most significant byte)	x	x	x	x	x	x	d9	d8	0x03	0x03	Read and write
0x05	VCOMMAX_L	VCOMMAX (least significant byte)	d7	d6	d5	d4	d3	d2	d1	d0	0xFF	0xFF	Read and write
0x06	VCOM_M	VCOM (most significant byte)	x	x	x	x	x	x	d9	d8	0x02	0x02	Read and write
0x07	VCOM_L	VCOM (least significant byte)	d7	d6	d5	d4	d3	d2	d1	d0	0x00	0x00	Read and write
0x08	GMA0_M	Gamma 0 (most significant byte)	x	x	x	x	x	x	d9	d8	0x03	0x03	Read and write
0x09	GMA0_L	Gamma 0 (least significant byte)	d7	d6	d5	d4	d3	d2	d1	d0	0x80	0x80	Read and write
0x0A	GMA1_M	Gamma 1 (most significant byte)	x	x	x	x	x	x	d9	d8	0x03	0x03	Read and write
0x0B	GMA1_L	Gamma 1 (least significant byte)	d7	d6	d5	d4	d3	d2	d1	d0	0x40	0x40	Read and write

Note: d0, d1, d2, d3, d4, d5, d6, d7, d8, d9 = valid data bits; x = don't care.

6/8/10-Channel, 10-Bit, Nonvolatile Programmable Gamma and VCOM Reference Voltages

Table 8. MAX9667 Register Description (continued)

REGISTER ADDRESS	REGISTER NAME	REGISTER DESCRIPTION	BIT								POWER-ON RESET VALUE	MTP FACTORY INITIALIZATION VALUE	READ AND WRITE?	
			7	6	5	4	3	2	1	0				
0x0C	GMA2_M	Gamma 2 (most significant byte)	x	x	x	x	x	x	x	d9	d8	0x03	0x03	Read and write
0x0D	GMA2_L	Gamma 2 (least significant byte)	d7	d6	d5	d4	d3	d2	d1	d0		0x00	0x00	Read and write
0x0E	GMA3_M	Gamma 3 (most significant byte)	x	x	x	x	x	x	x	d9	d8	0x02	0x02	Read and write
0x0F	GMA3_L	Gamma 3 (least significant byte)	d7	d6	d5	D4	d3	d2	d1	d0		0xC0	0xC0	Read and write
0x10	GMA4_M	Gamma 4 (most significant byte)	x	x	x	x	x	x	x	d9	d8	0x02	0x02	Read and write
0x11	GMA4_L	Gamma 4 (least significant byte)	d7	d6	d5	d4	d3	d2	d1	d0		0x80	0x80	Read and write
0x12	GMA5_M	Gamma 5 (most significant byte)	x	x	x	x	x	x	x	d9	d8	0x01	0x01	Read and write
0x13	GMA5_L	Gamma 5 (least significant byte)	d7	d6	d5	d4	d3	d2	d1	d0		0x80	0x80	Read and write
0x14	GMA6_M	Gamma 6 (most significant byte)	x	x	x	x	x	x	x	d9	d8	0x01	0x01	Read and write
0x15	GMA6_L	Gamma 6 (least significant byte)	d7	d6	d5	d4	d3	d2	d1	d0		0x40	0x40	Read and write

Note: d0, d1, d2, d3, d4, d5, d6, d7, d8, d9 = valid data bits; x = don't care.

6/8/10-Channel, 10-Bit, Nonvolatile Programmable Gamma and VCOM Reference Voltages

MAX9665/MAX9666/MAX9667

Table 8. MAX9667 Register Description (continued)

REGISTER ADDRESS	REGISTER NAME	REGISTER DESCRIPTION	BIT								POWER-ON RESET VALUE	MTP FACTORY INITIALIZATION VALUE	READ AND WRITE?	
			7	6	5	4	3	2	1	0				
0x16	GMA7_M	Gamma 7 (most significant byte)	x	x	x	x	x	x	x	d9	d8	0x01	0x01	Read and write
0x17	GMA7_L	Gamma 7 (least significant byte)	d7	d6	d5	d4	d3	d2	d1	d0		0x00	0x00	Read and write
0x18	GMA8_M	Gamma 8 (most significant byte)	x	x	x	x	x	x	x	d9	d8	0x00	0x00	Read and write
0x19	GMA8_L	Gamma 8 (least significant byte)	d7	d6	d5	d4	d3	d2	d1	d0		0xC0	0xC0	Read and write
0x1A	GMA9_M	Gamma 9 (most significant byte)	x	x	x	x	x	x	x	d9	d8	0x00	0x00	Read and write
0x1B	GMA9_L	Gamma 9 (least significant byte)	d7	d6	d5	d4	d3	d2	d1	d0		0x80	0x80	Read and write

Note: d0, d1, d2, d3, d4, d5, d6, d7, d8, d9 = valid data bits; x = don't care.

Table 9. Command Set

MACHINE CODE FOR OPERATION*	OPERATION	OPERANDS	DESCRIPTION
0x00	NOP	None	No operation.
0x01	MOV	Source, destination	Move data in source location to destination location. Source location is bits 4 through 7, and destination location is bits 0 through 3. Source locations and destination locations must be of the same type. For example, commands that move data from the VCOM registers to the gamma registers and vice-versa are not valid, and the I ² C interface issues a NACK.

*Write to I²C Register 0x00.

6/8/10-Channel, 10-Bit, Nonvolatile Programmable Gamma and VCOM Reference Voltages

Table 10. Example Commands for MOV Operation

I ² C REGISTER ADDRESS	0x00	0x01
Operation: Move Gamma register value to Gamma MTP memory	0x01	0x45
Operation: Move VCOM MTP memory to VCOM register	0x01	0x32
Operation: Move all register values to MTP memory	0x01	0x67

For a move (MOV) command, 0x01 should be written into I²C register 0x00, and the source and destination written in I²C register 0x01. See Table 10 for examples. The upper 4 bits (7 to 4) designate the source, and the lower 4 bits (3 to 0) destination, per Table 11.

It takes 30ms (typ) and 32ms (max) to move one I²C register to MTP memory. Thus, it needs 400ms (typ) and 450ms (max) to program all I²C registers to MTP memory for VCOM window, VCOM, and gamma.

The command operand and operation registers must be written to consecutively, otherwise the command does not execute.

Single-Wire Interface

The MAX9665/MAX9666/MAX9667 have a single-wire interface that is compatible with the MAX1512 interface.

Table 11. Source and Destination Locations for MOV Command

LOCATION CODE	DESCRIPTION
0b0000	VCOM Window Registers
0b0001	VCOM Window MTP Memory
0b0010	VCOM Register
0b0011	VCOM MTP Memory
0b0100	Gamma Registers
0b0101	Gamma MTP Memory
0b0110	All Registers
0b0111	All MTP Memory

VCOM Adjustment (CTL)

Pulse CTL low for more than 200μs to increment the DAC setting, which lowers the VCOM level by 1 least-significant bit (LSB) (Figure 10). Similarly, pulse CTL high for more than 200μs, which raises the VCOM level by 1 LSB.

To avoid unintentional VCOM adjustment, the parts are guaranteed to reject CTL pulses shorter than 20μs. In addition, to avoid the possibility of a single false pulse caused by power-up sequencing between DVDD and CTL, the very first pulse is ignored.

6/8/10-Channel, 10-Bit, Nonvolatile Programmable Gamma and VCOM Reference Voltages

MAX9665/MAX9666/MAX9667

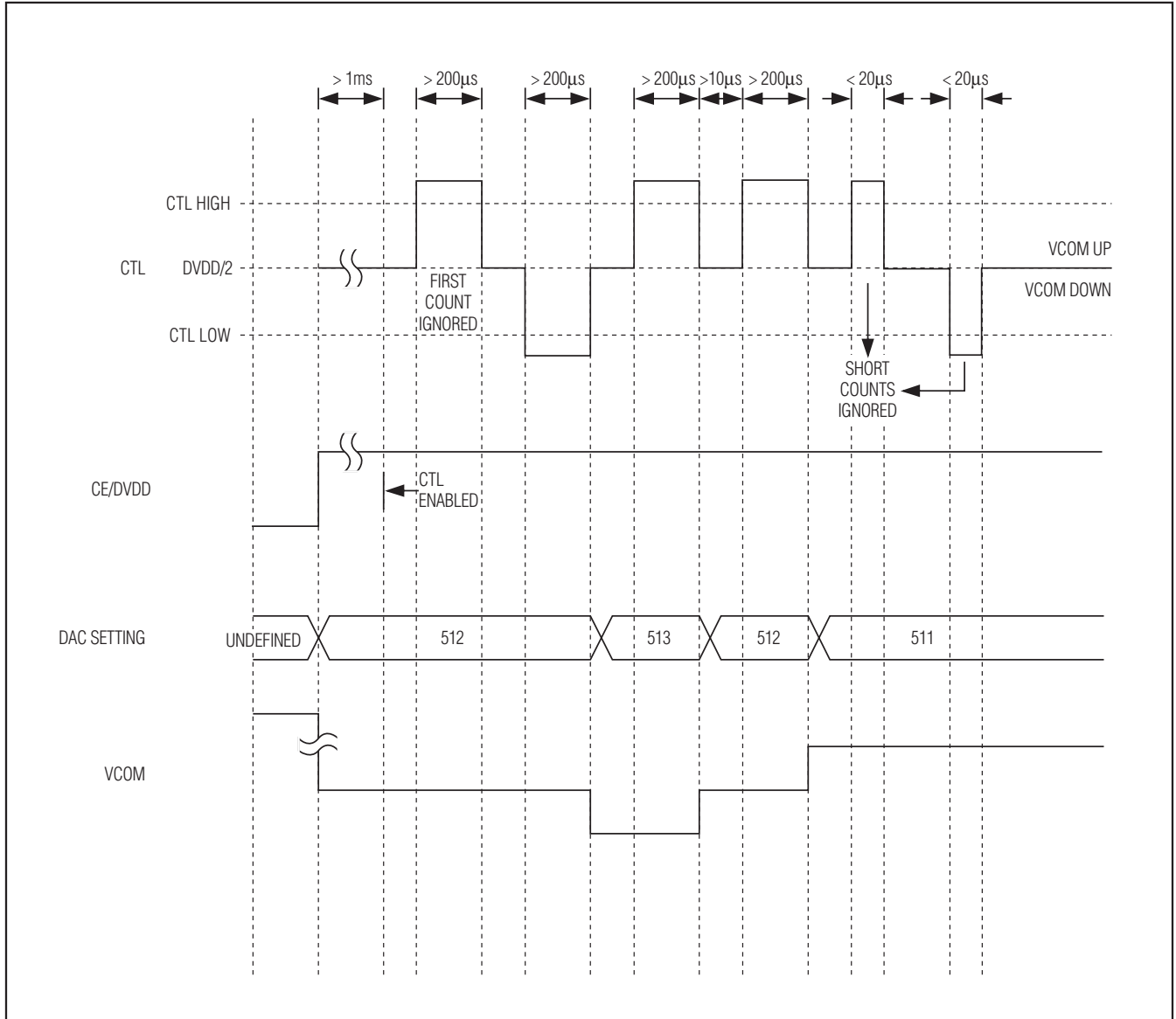

Figure 10. VCOM Adjustment

6/8/10-Channel, 10-Bit, Nonvolatile Programmable Gamma and VCOM Reference Voltages

MTP Programming (CTL)

To program the MTP memory, apply the MTP programming waveform through the CTL interface (Figure 11). Unlike the MAX1512, the control interface only delivers DAC adjustment commands, not programming power. AVDD must be valid for MTP programming to occur. If AVDD is not valid for MTP programming, the single-wire interface is in shutdown.

To apply the MTP programming waveform, carefully ramp CTL from midscale (DVDD/2) to the programming voltage, V_{P-P} , in 7.5ms as shown in Figure 11. If the ramp is generated digitally, use at least 45 steps to achieve the required 320mV ramp resolution. During the ramp time, VCOM adjustment is disabled and the MTP cell is biased in preparation for programming. After reaching V_{P-P} , hold CTL at V_{P-P} for 1ms. During the MTP program time, the MTP memory stores the DAC setting. Next, drive CTL to ground in less than 1ms and hold for at least 200 μ s. Finally, drive CTL to DVDD/2 to complete the write cycle. The MTP memory is factory set to half scale. Follow the MTP programming specification in Table 12 to guarantee reliable MTP memory programming. Violating the specifications can damage the MTP memory or affect data retention.

Table 12 shows the timing and voltage parameters for MTP programming. This table is used for programming through the single-wire interface.

Single-Wire Interface Enable/Disable (CE)

The single-wire interface can be disabled to reduce the DVDD supply current. Connect CE to GND to reduce the typical supply current from 450 μ A to 320 μ A. Connect CE to DVDD to enable the single-wire interface.

The programming circuit in Figure 12 drives CE high to enable the CTL input when it is connected. When the programming circuit is not connected, CE is pulled low through resistor R_{CE} , which disables the CTL input. The CTL input is relatively immune to noise and brief voltage transients. It can be safely left continuously enabled if higher supply current is acceptable.

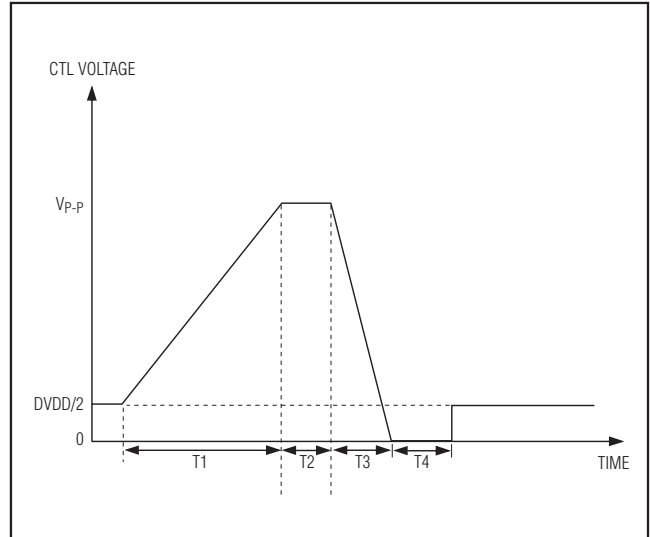

Figure 11. MTP Memory Programming

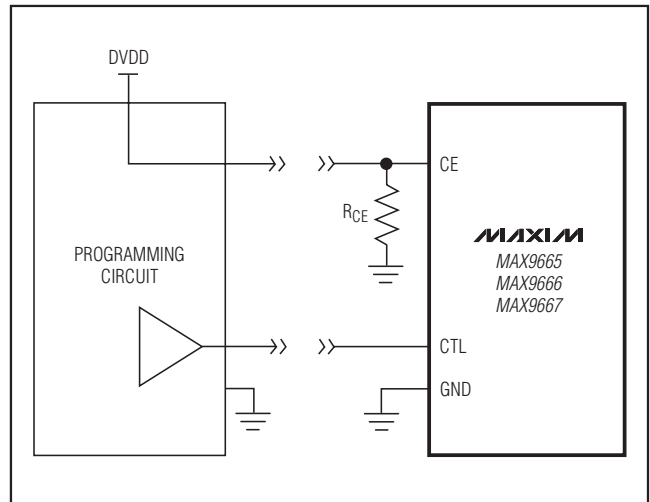

Figure 12. Optional Circuit to Drive CE

Table 12. MTP Memory Programming Specifications

PARAMETER	SYMBOL	MIN	TYP	MAX	UNITS
CTL Programming Voltage	V_{P-P}	15.25	15.5	15.75	V
CTL Programming Ramp	T1	7.0	7.5	8.0	ms
MTP Memory Program Time	T2	0.9	1.0	1.1	ms
V_{P-P} Fall Time	T3	10	—	1000	μ s
Done Hold Time	T4	200	—	—	μ s

6/8/10-Channel, 10-Bit, Nonvolatile Programmable Gamma and VCOM Reference Voltages

Applications Information

Power-Up and Power-Down

Figure 13 below shows the power-up sequence. The digital supply must be powered up first. The analog supply should not be powered up for at least 350µs (min) after the digital supply has been powered up.

During this time, the MTP register values are loaded into the I²C registers and the default I²C register values are overwritten. Once AVDD is above approximately 8V, the output buffers have enough headroom and power up proportionally with the AVDD.

For power-down, AVDD must be lowered first to 0V, and then DVDD can safely be powered down.

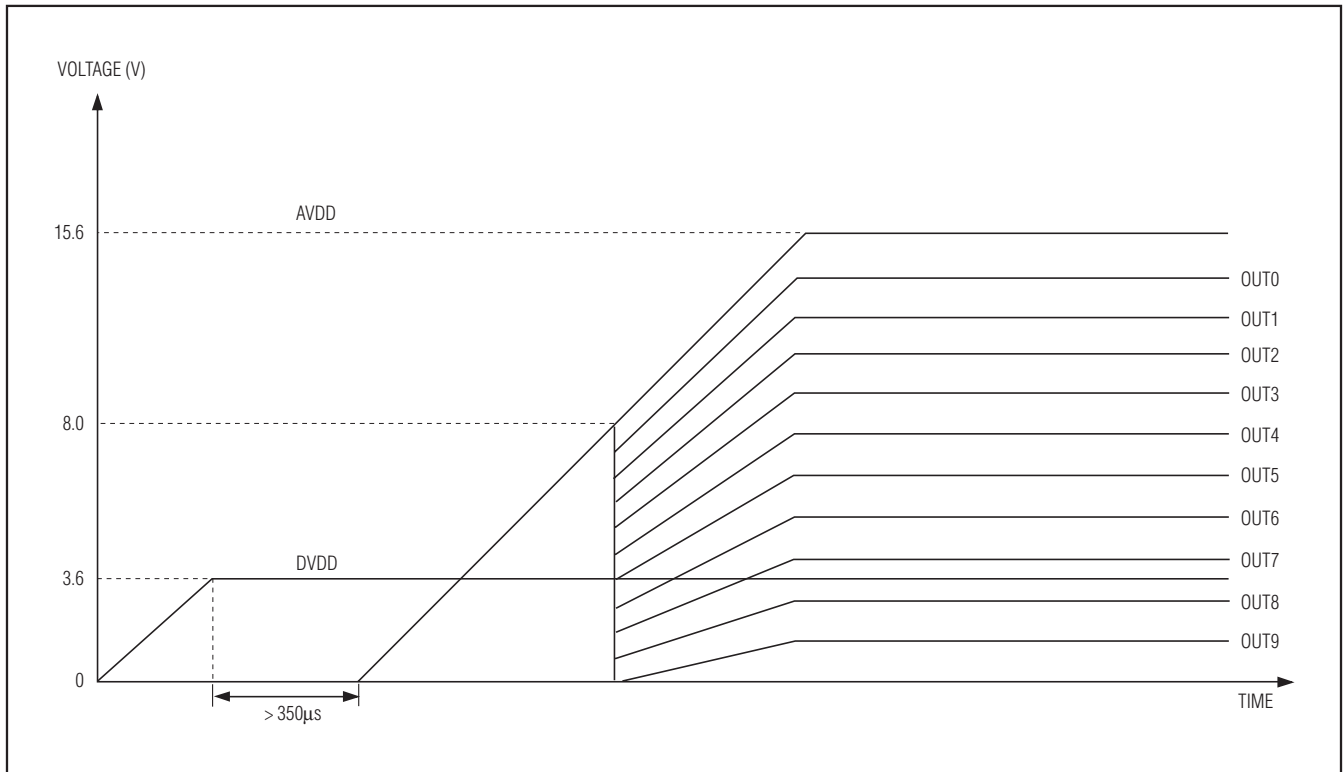

Figure 13. Power-Up Sequence

6/8/10-Channel, 10-Bit, Nonvolatile Programmable Gamma and VCOM Reference Voltages

Electrostatic Discharge (CTL, CE)

Often, CTL and CE are exposed at the panel connector and are therefore subject to electrostatic discharge (ESD). Resistor-capacitor (RC) filters can be employed at these inputs to improve their ESD performance (Figure 14).

If the CE panel connector is to be left unconnected after programming, be sure to include a resistor to ground (R_{CE}) to ensure a valid logic-low on CE. The time constant for a CE filter is not critical, but the driving resistor must have a much lower resistance than R_{CE} to properly drive CE. If a filter is used at the CTL panel connector, its RC time-constant should be short enough to avoid interfering with CTL pulses or MTP memory programming timing. A time constant less than 200 μ s does not interfere with MTP memory programming. To avoid interfering with CTL pulses, make the time constant small compared to the CTL pulse width needed.

Leakage Current (CTL)

The CTL pin is internally biased to DVDD/2, but it is sensitive to leakage currents above 0.1 μ A. When CTL is not driven, avoid leakage currents around the CTL pin. Otherwise, reinforce the DVDD/2 set point with an external resistive voltage-divider.

Power Supplies and Bypass Capacitors

The MAX9665/MAX9666/MAX9667 operate from a single 9V to 20V analog supply and a 2.5V to 3.6V digital supply. Bypass AVDD to GND with 0.1 μ F and 10 μ F capacitors in parallel. Use an extensive ground plane to ensure optimum performance. Bypass DVDD to GND with a 0.1 μ F capacitor. Refer to the MAX9665/MAX9666/MAX9667 evaluation kit for a proven PCB layout.

Layout and Grounding

The exposed pad on the TQFN package is electrically connected to GND. Solder the exposed pad to a ground plane to provide a low thermal resistance to ground for heat dissipation. Do not route traces under these packages.

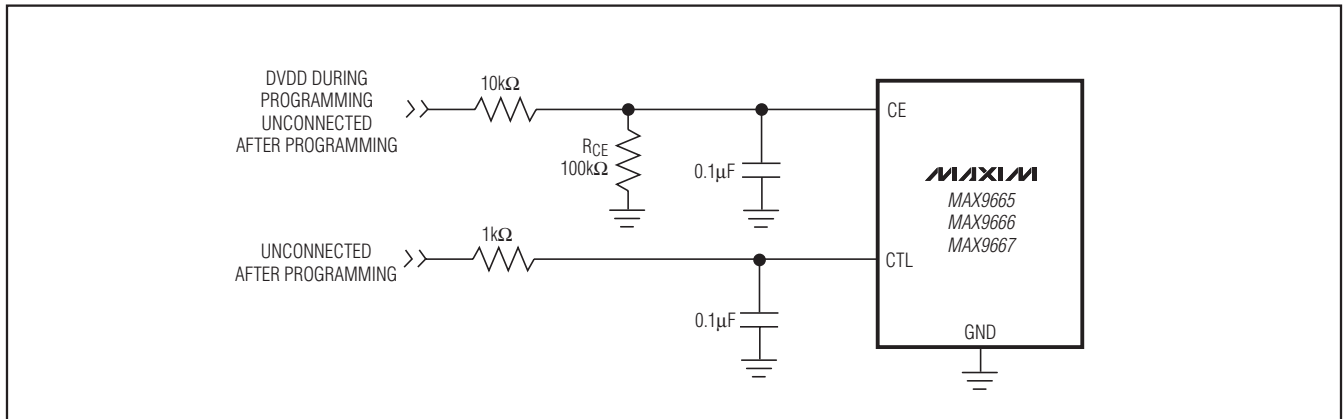
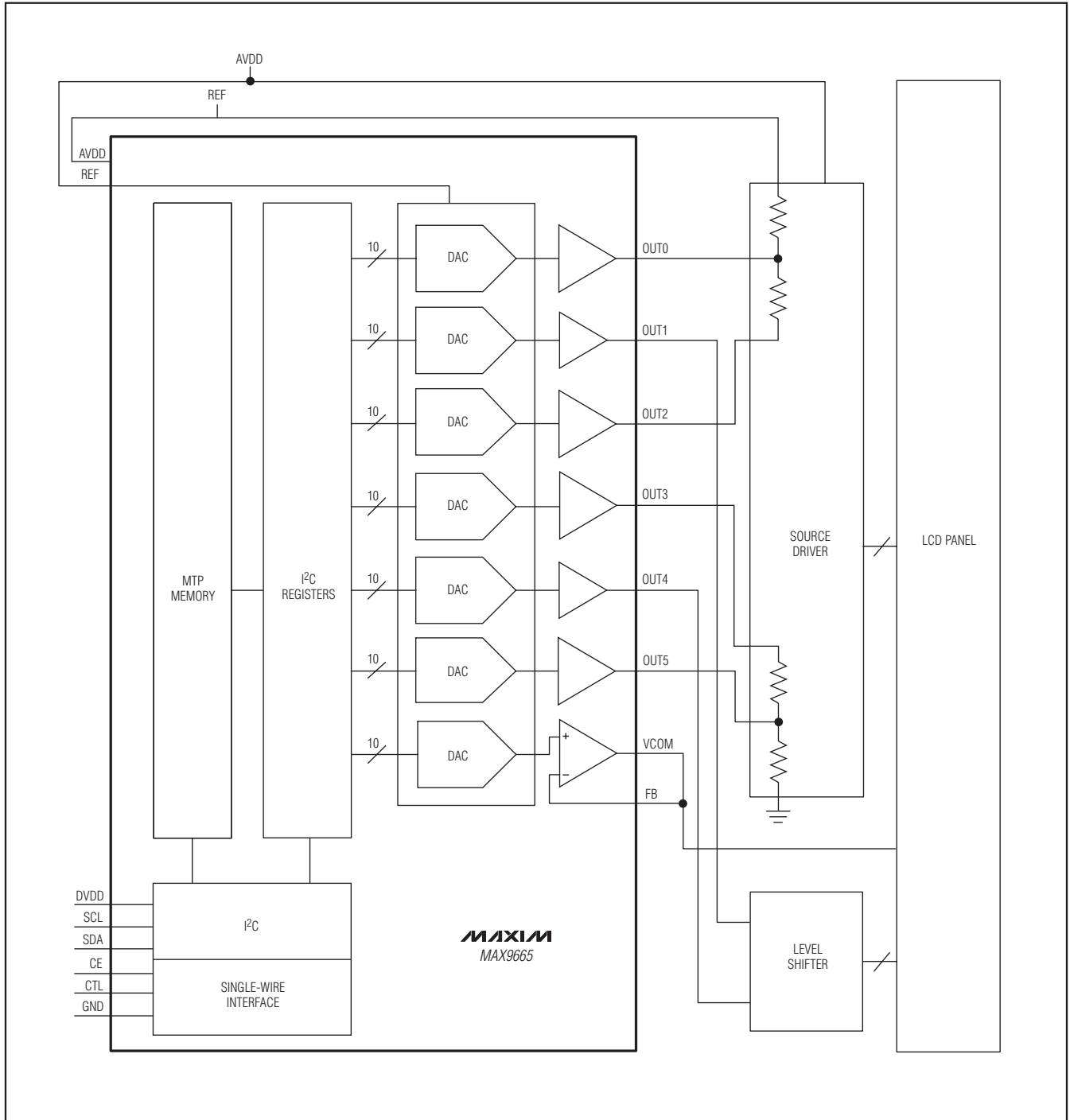

Figure 14. Improved EOS/Surge Performance

6/8/10-Channel, 10-Bit, Nonvolatile Programmable Gamma and VCOM Reference Voltages

Typical Operating Circuits

MAX9665/MAX9666/MAX9667



6/8/10-Channel, 10-Bit, Nonvolatile Programmable Gamma and VCOM Reference Voltages

Typical Operating Circuits (continued)

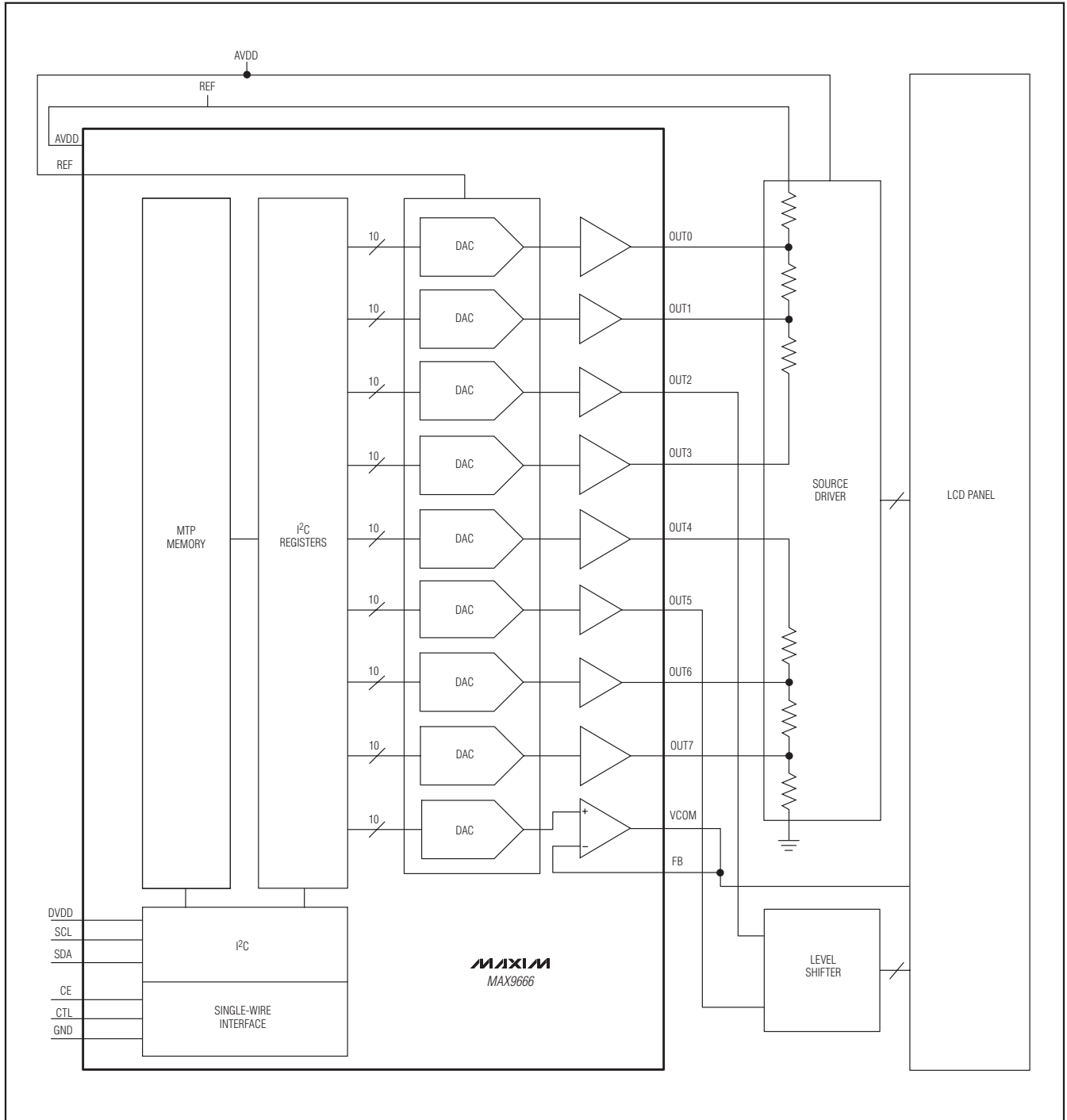

6/8/10-Channel, 10-Bit, Nonvolatile Programmable Gamma and VCOM Reference Voltages

Typical Operating Circuits (continued)

MAX9665/MAX9666/MAX9667

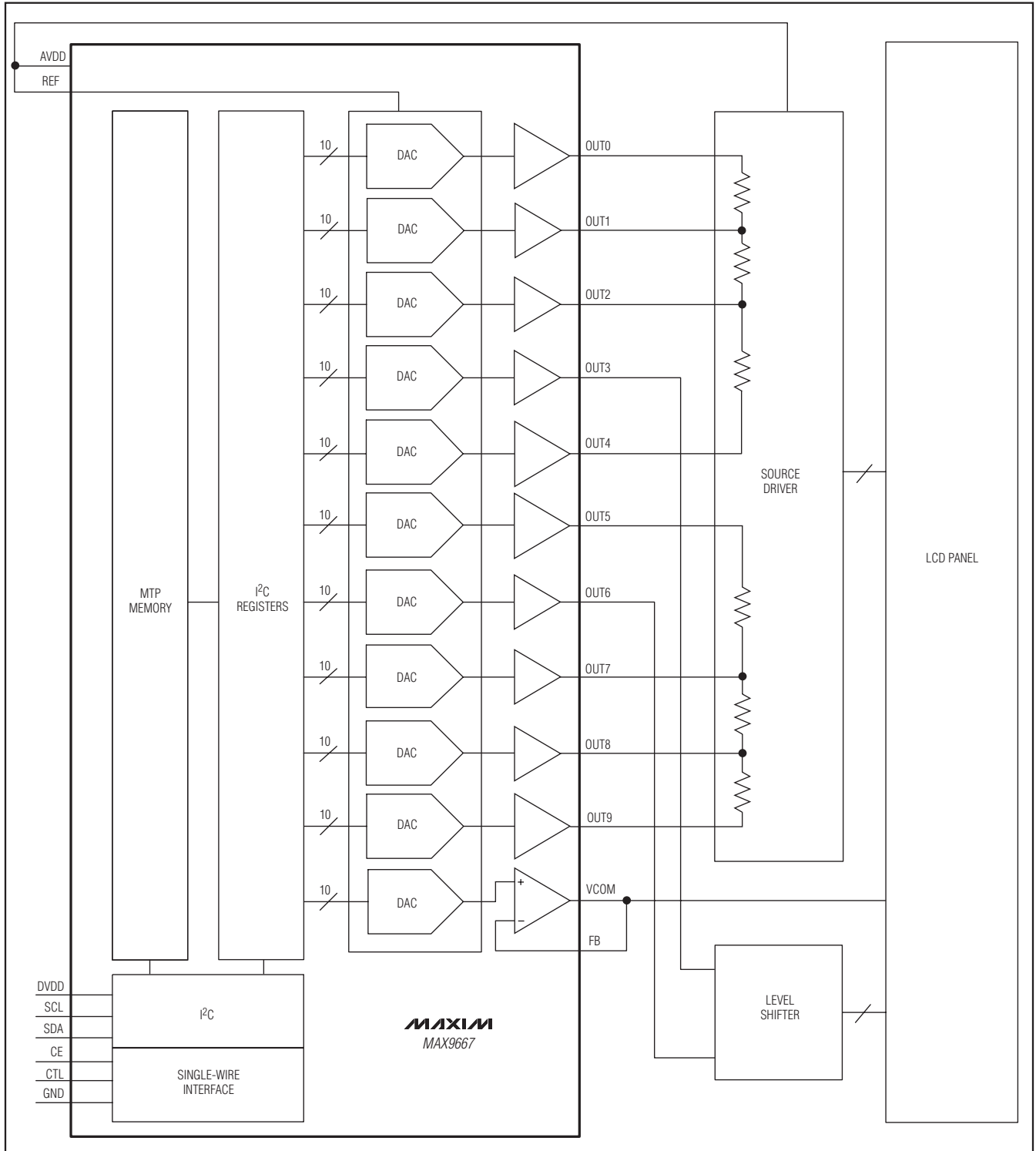

6/8/10-Channel, 10-Bit, Nonvolatile Programmable Gamma and VCOM Reference Voltages

Functional Diagrams (continued)

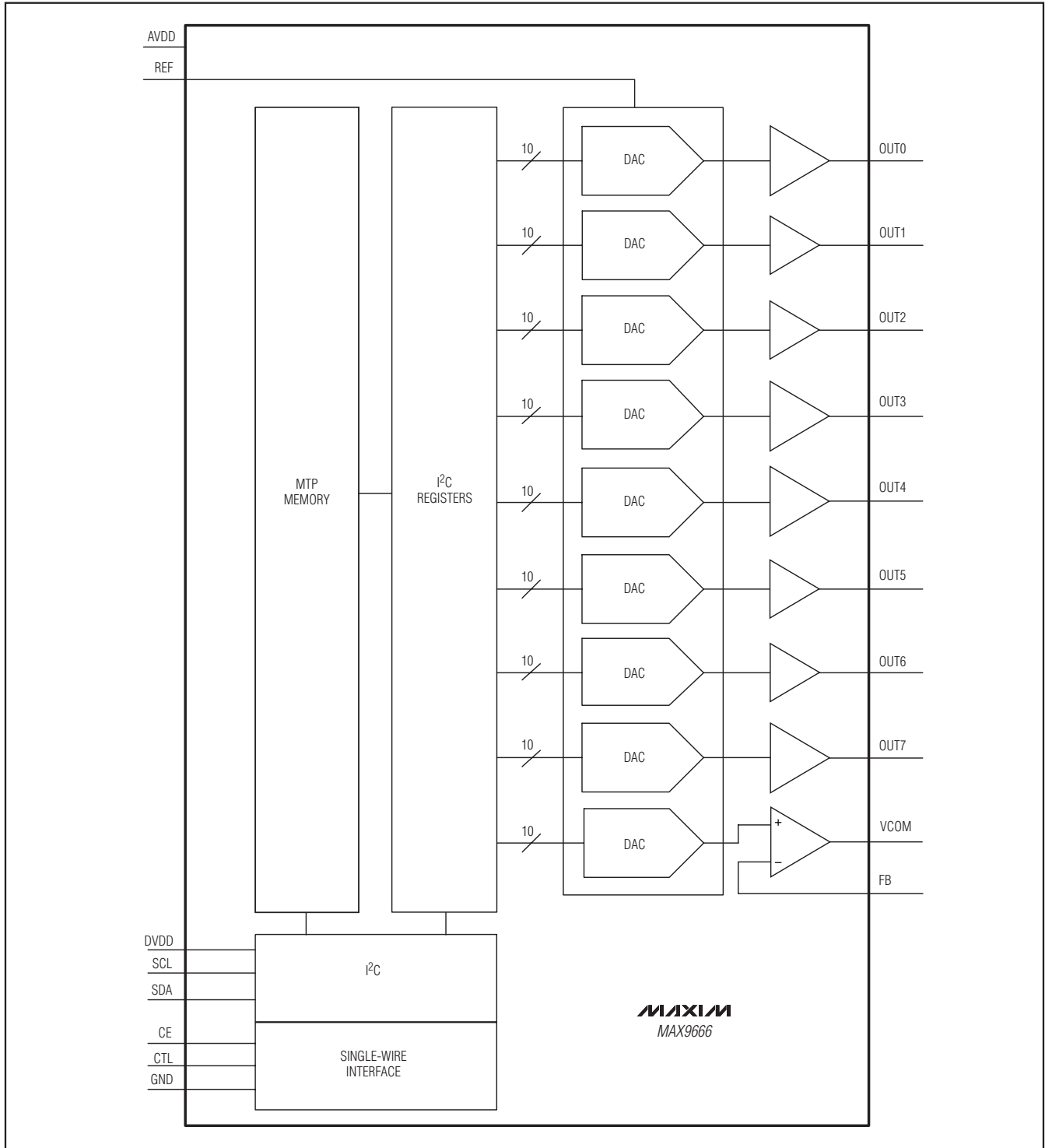

6/8/10-Channel, 10-Bit, Nonvolatile Programmable Gamma and VCOM Reference Voltages

Functional Diagrams (continued)

MAX9665/MAX9666/MAX9667

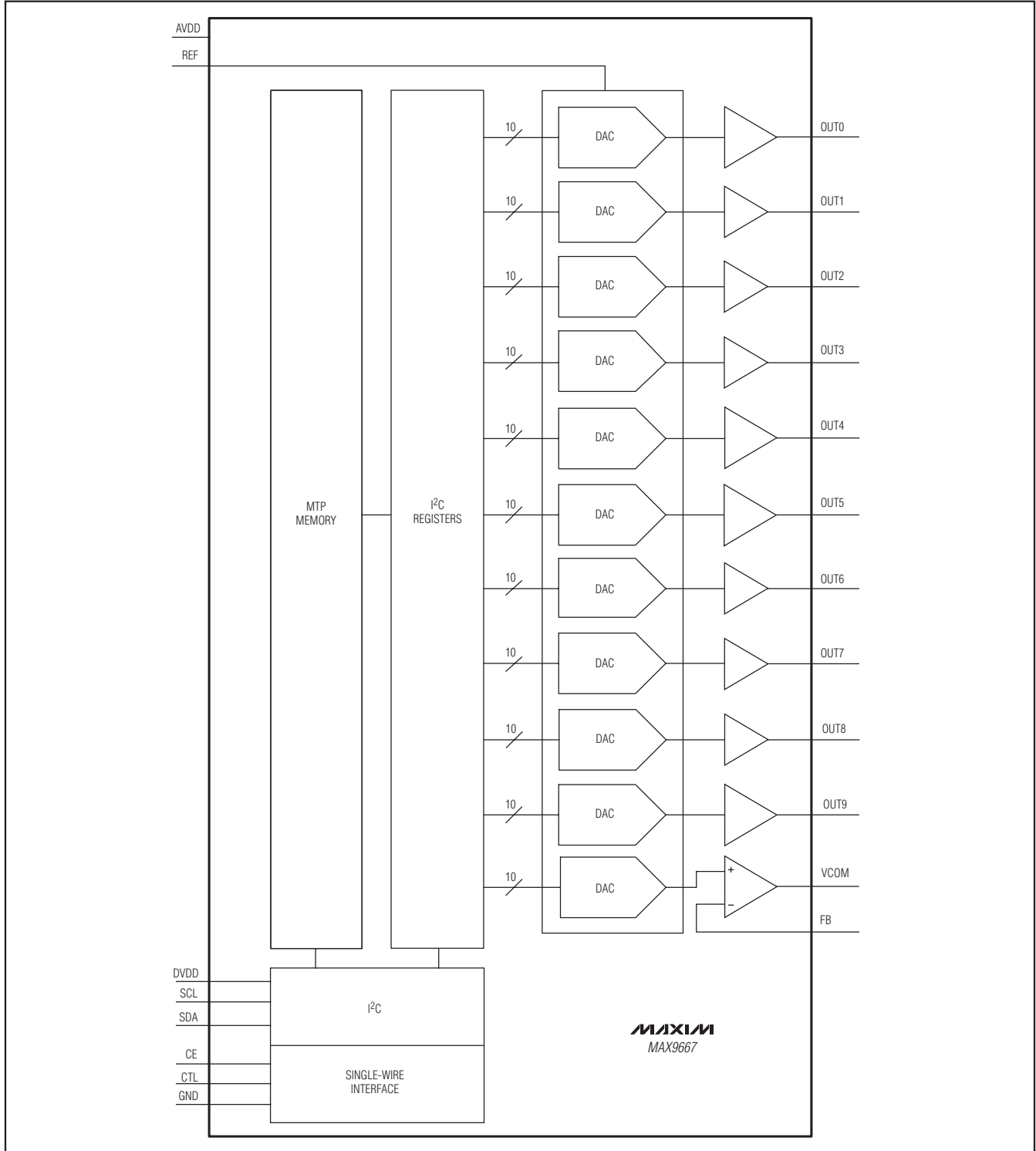

6/8/10-Channel, 10-Bit, Nonvolatile Programmable Gamma and VCOM Reference Voltages

Pin Configurations (continued)

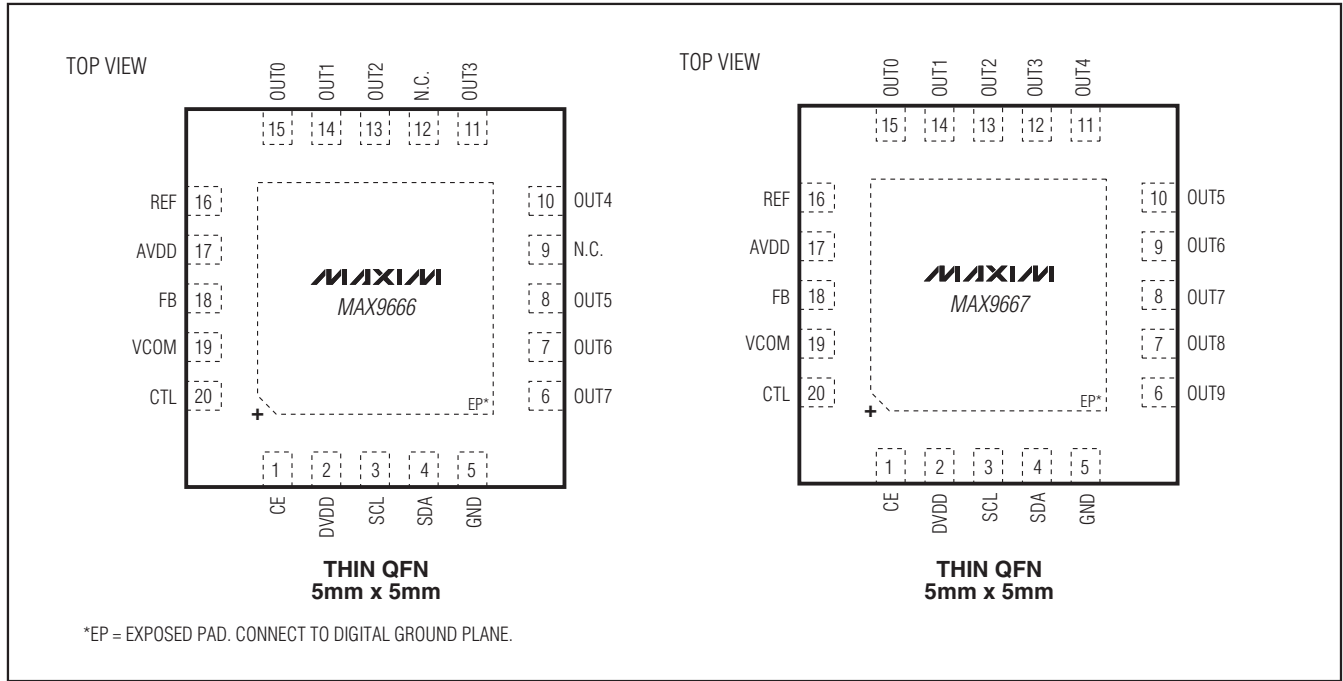

6/8/10-Channel, 10-Bit, Nonvolatile Programmable Gamma and VCOM Reference Voltages

Package Information

For the latest package outline information and land patterns, go to www.maxim-ic.com/packages. Note that a "+", "#", or "-" in the package code indicates RoHS status only. Package drawings may show a different suffix character, but the drawing pertains to the package regardless of RoHS status.

PACKAGE TYPE	PACKAGE CODE	OUTLINE NO.	LAND PATTERN NO.
20 TQFN-EP	T2055+3	21-0140	90-0121

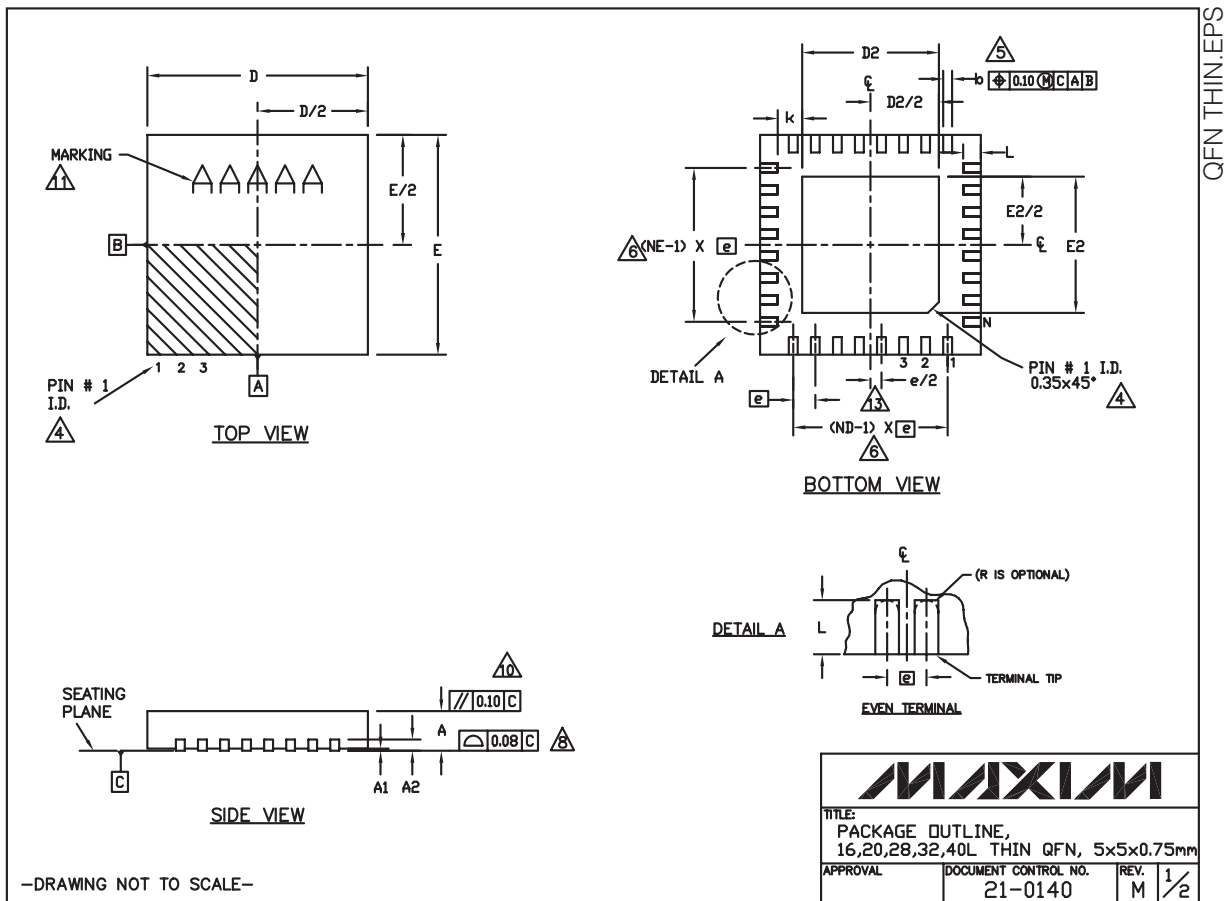

MAX9665/MAX9666/MAX9667

6/8/10-Channel, 10-Bit, Nonvolatile Programmable Gamma and VCOM Reference Voltages

Package Information (continued)

For the latest package outline information and land patterns, go to www.maxim-ic.com/packages. Note that a "+", "#", or "-" in the package code indicates RoHS status only. Package drawings may show a different suffix character, but the drawing pertains to the package regardless of RoHS status.

COMMON DIMENSIONS															
PKG.	16L 5x5			20L 5x5			28L 5x5			32L 5x5			40L 5x5		
SYMBOL	MIN.	NDM.	MAX.	MIN.	NDM.	MAX.	MIN.	NDM.	MAX.	MIN.	NDM.	MAX.	MIN.	NDM.	MAX.
A	0.70	0.75	0.80	0.70	0.75	0.80	0.70	0.75	0.80	0.70	0.75	0.80	0.70	0.75	0.80
A1	0	0.02	0.05	0	0.02	0.05	0	0.02	0.05	0	0.02	0.05	0	0.02	0.05
A2	0.20 REF.			0.20 REF.			0.20 REF.			0.20 REF.			0.20 REF.		
b	0.25	0.30	0.35	0.25	0.30	0.35	0.20	0.25	0.30	0.20	0.25	0.30	0.15	0.20	0.25
D	4.90	5.00	5.10	4.90	5.00	5.10	4.90	5.00	5.10	4.90	5.00	5.10	4.90	5.00	5.10
E	4.90	5.00	5.10	4.90	5.00	5.10	4.90	5.00	5.10	4.90	5.00	5.10	4.90	5.00	5.10
e	0.80 BSC.			0.65 BSC.			0.50 BSC.			0.50 BSC.			0.40 BSC.		
k	0.25	-	-	0.25	-	-	0.25	-	-	0.25	-	-	0.25	-	-
L	0.30	0.40	0.50	0.45	0.55	0.65	0.45	0.55	0.65	0.30	0.40	0.50	0.30	0.40	0.50
N	16			20			28			32			40		
ND	4			5			7			8			10		
NE	4			5			7			8			10		
JEDEC	WHHB			WHHC			WHHD-1			WHHD-2			-----		

EXPOSED PAD VARIATIONS						
PKG. CODES	D2			E2		
	MIN.	NDM.	MAX.	MIN.	NDM.	MAX.
T1655-2	3.00	3.10	3.20	3.00	3.10	3.20
T1655-3	3.00	3.10	3.20	3.00	3.10	3.20
T1655-4	2.19	2.29	2.39	2.19	2.29	2.39
T165N-1	3.00	3.10	3.20	3.00	3.10	3.20
T2055-3	3.00	3.10	3.20	3.00	3.10	3.20
T2055-4	3.00	3.10	3.20	3.00	3.10	3.20
T2055-5	3.15	3.25	3.35	3.15	3.25	3.35
T2055MN-5	3.15	3.25	3.35	3.15	3.25	3.35
T2855-3	3.15	3.25	3.35	3.15	3.25	3.35
T2855-4	2.60	2.70	2.80	2.60	2.70	2.80
T2855-5	2.60	2.70	2.80	2.60	2.70	2.80
T2855-6	3.15	3.25	3.35	3.15	3.25	3.35
T2855-7	2.60	2.70	2.80	2.60	2.70	2.80
T2855-8	3.15	3.25	3.35	3.15	3.25	3.35
T2855N-1	3.15	3.25	3.35	3.15	3.25	3.35
T3255-3	3.00	3.10	3.20	3.00	3.10	3.20
T3255-4	3.00	3.10	3.20	3.00	3.10	3.20
T3255M-4	3.00	3.10	3.20	3.00	3.10	3.20
T3255-5	3.00	3.10	3.20	3.00	3.10	3.20
T3255N-1	3.00	3.10	3.20	3.00	3.10	3.20
T4055-1	3.40	3.50	3.60	3.40	3.50	3.60
T4055-2	3.40	3.50	3.60	3.40	3.50	3.60
T4055N-1	3.40	3.50	3.60	3.40	3.50	3.60
T4055MN-1	3.40	3.50	3.60	3.40	3.50	3.60

NOTES:

- DIMENSIONING & TOLERANCING CONFORM TO ASME Y14.5M-1994.
- ALL DIMENSIONS ARE IN MILLIMETERS. ANGLES ARE IN DEGREES.
- N IS THE TOTAL NUMBER OF TERMINALS.
- THE TERMINAL #1 IDENTIFIER AND TERMINAL NUMBERING CONVENTION SHALL CONFORM TO JEDEC 95-1 SPP-012. DETAILS OF TERMINAL #1 IDENTIFIER ARE OPTIONAL, BUT MUST BE LOCATED WITHIN THE ZONE INDICATED. THE TERMINAL #1 IDENTIFIER MAY BE EITHER A MOLD OR MARKED FEATURE.
- DIMENSION b APPLIES TO METALLIZED TERMINAL AND IS MEASURED BETWEEN 0.25 mm AND 0.30 mm FROM TERMINAL TIP.
- ND AND NE REFER TO THE NUMBER OF TERMINALS ON EACH D AND E SIDE RESPECTIVELY.
- DEPOPULATION IS POSSIBLE IN A SYMMETRICAL FASHION.
- COPLANARITY APPLIES TO THE EXPOSED HEAT SINK SLUG AS WELL AS THE TERMINALS.
- DRAWING CONFORMS TO JEDEC MO220, EXCEPT EXPOSED PAD DIMENSION FOR T2855-3, T2855-6, T4055-1 AND T4055-2.
- WARPAGE SHALL NOT EXCEED 0.10 mm.
- MARKING IS FOR PACKAGE ORIENTATION REFERENCE ONLY.
- NUMBER OF LEADS SHOWN ARE FOR REFERENCE ONLY.
- LEAD CENTERLINES TO BE AT TRUE POSITION AS DEFINED BY BASIC DIMENSION 'e', ±0.05.
- ALL DIMENSIONS APPLY TO BOTH LEADED (-) AND PbFREE (+) PKG. CODES.

-DRAWING NOT TO SCALE-

		
TITLE: PACKAGE OUTLINE, 16,20,28,32,40L THIN QFN, 5x5x0.75mm		
APPROVAL	DOCUMENT CONTROL NO. 21-0140	REV. M 2/2

6/8/10-Channel, 10-Bit, Nonvolatile Programmable Gamma and VCOM Reference Voltages

Revision History

REVISION NUMBER	REVISION DATE	DESCRIPTION	PAGES CHANGED
0	10/09	Initial release	—
1	11/09	Added soldering temperature (reflow) and made minor updates	1, 2, 10, 38
2	1/10	Updated MTP write qualification and MOV command description	1, 10, 12, 28, 30
3	3/10	Corrected various errors and added soldering temperature	1, 2, 3, 5–9, 15–20, 22, 25, 30, 31, 33, 38
4	7/10	Corrected terminology in TOCs 2 and 3 and typos	6, 16, 17

MAX9665/MAX9666/MAX9667

Maxim cannot assume responsibility for use of any circuitry other than circuitry entirely embodied in a Maxim product. No circuit patent licenses are implied. Maxim reserves the right to change the circuitry and specifications without notice at any time.

Maxim Integrated Products, 120 San Gabriel Drive, Sunnyvale, CA 94086 408-737-7600 _____ 41

Looking for pricing, stock, or lifecycle information?

Click below to explore more details on WIN SOURCE:

 [View MAX9667ETP+T on WIN SOURCE](#)

 [Maxim Integrated](#) Information

Optimize Your Supply Chain with WIN SOURCE Solutions

-  Global Sourcing Solution
-  Obsolete Management
-  Cost Control Management
-  Shortage Management
-  Alternative Solution
-  Excess Inventory Management