

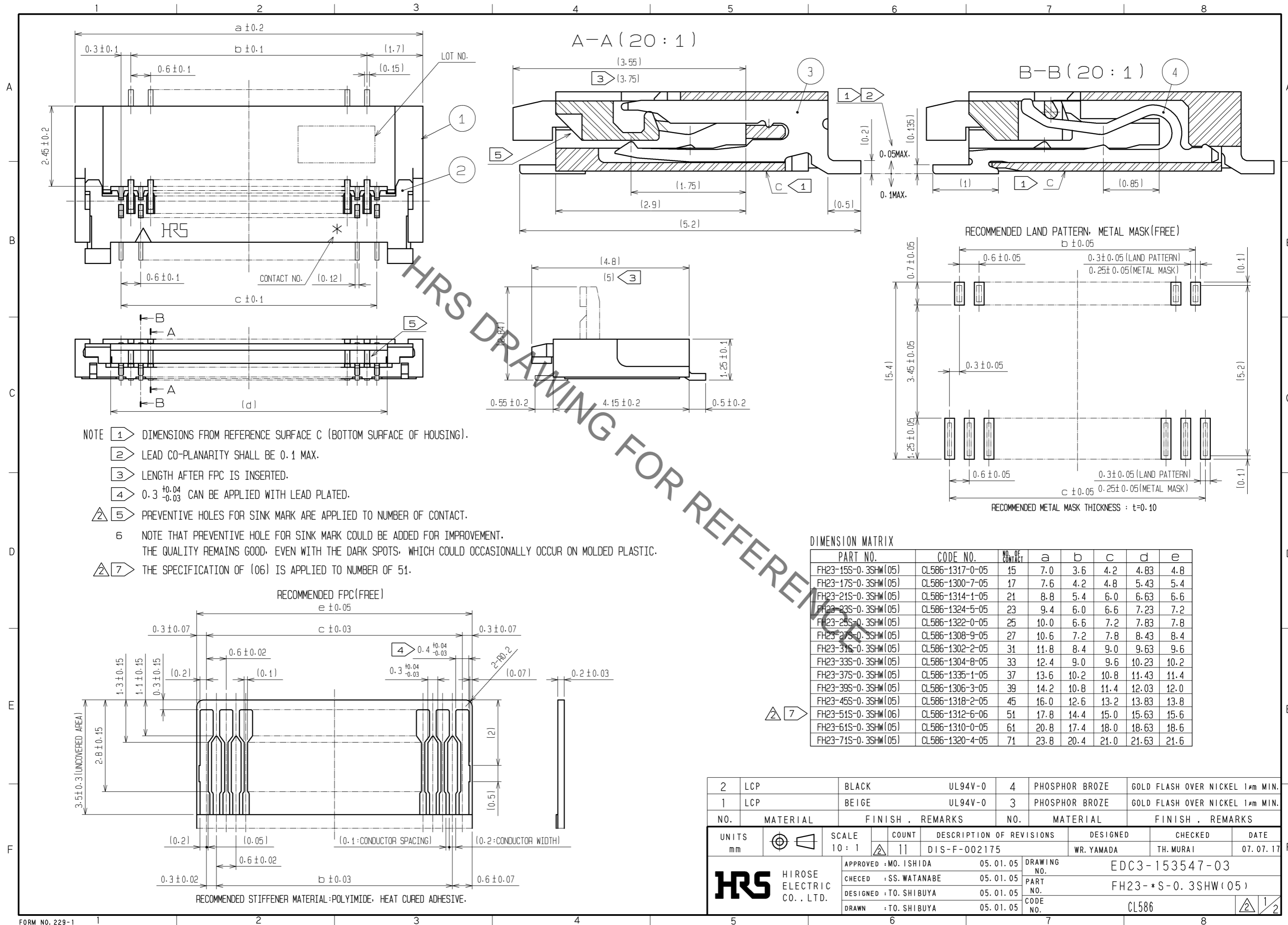

**THE DATASHEET OF
FH23-25S-0.3SHW(05)**



Jul.1.2019 Copyright 2019 HIROSE ELECTRIC CO., LTD. All Rights Reserved.
 In case of consideration for using Automotive equipment / device which demand high reliability, kindly contact our sales window correspondents.



2	LCP	BLACK	UL94V-0	4	PHOSPHOR BROZE	GOLD FLASH OVER NICKEL 1μm MIN.	
1	LCP	BEIGE	UL94V-0	3	PHOSPHOR BROZE	GOLD FLASH OVER NICKEL 1μm MIN.	
NO.	MATERIAL	FINISH	REMARKS	NO.	MATERIAL	FINISH	REMARKS
UNITS	mm	SCALE	10:1	COUNT	11	DESCRIPTION OF REVISIONS	DIS-F-002175
APPROVED : MO. ISHIDA 05.01.05				DESIGNED			WR. YAMADA
CHECKED : SS. WATANABE 05.01.05				CHECKED			TH. MURAI
DESIGNED : TO. SHIBUYA 05.01.05				DATE			07.07.17
DRAWN : TO. SHIBUYA 05.01.05				DRAWING NO.			EDC3-153547-03
HRS HIROSE ELECTRIC CO., LTD.				PART NO.			FH23-*S-0.3SHW(05)
				CODE NO.			CL586

Jul.1.2019 Copyright 2019 HIROSE ELECTRIC CO., LTD. All Rights Reserved.
 In case of consideration for using Automotive equipment / device which demand high reliability, kindly contact our sales window correspondents.

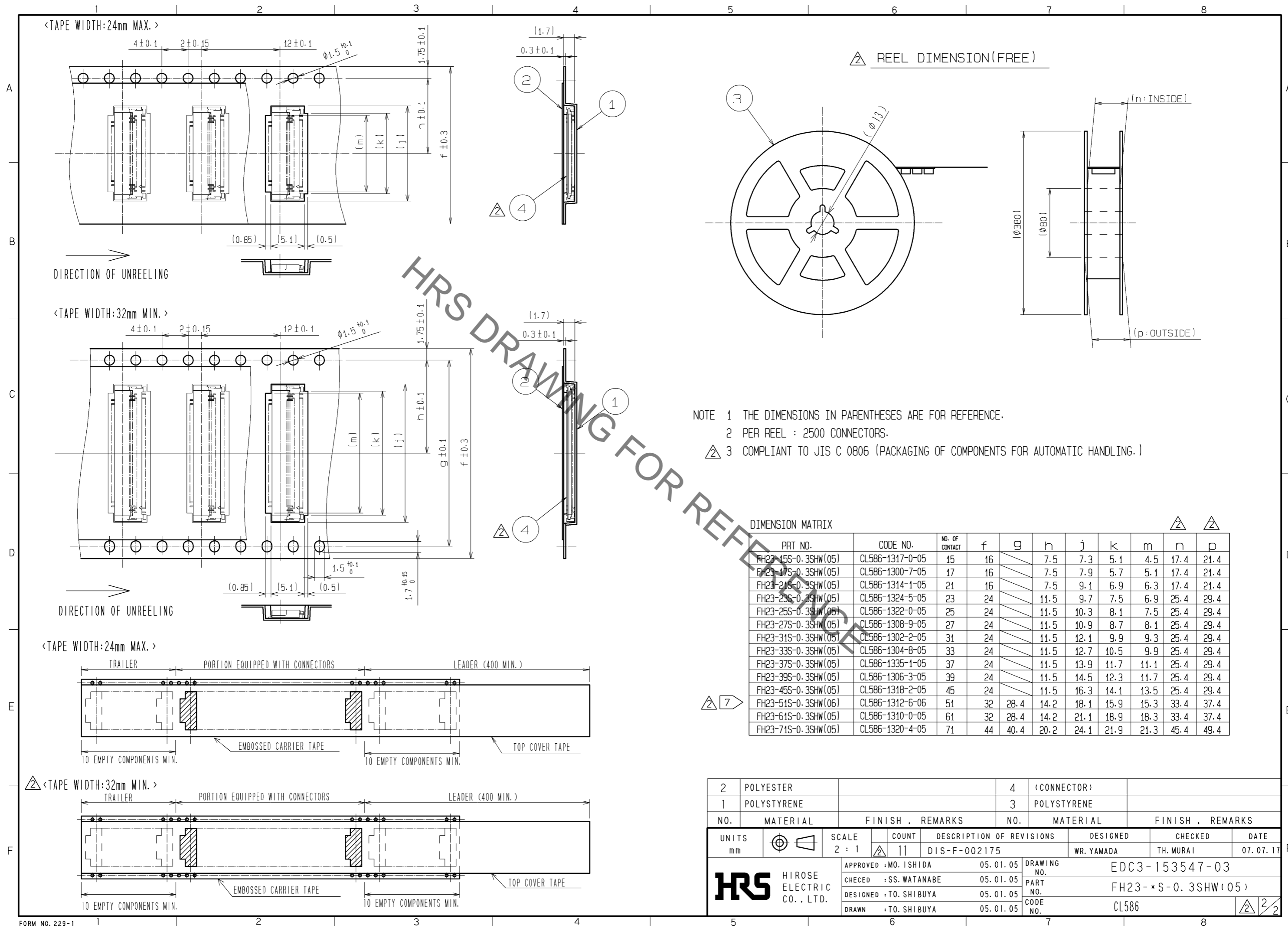

HRS DRAWING FOR REFERENCE

NOTE 1 THE DIMENSIONS IN PARENTHESES ARE FOR REFERENCE.
 2 PER REEL : 2500 CONNECTORS.
 3 COMPLIANT TO JIS C 0806 (PACKAGING OF COMPONENTS FOR AUTOMATIC HANDLING.)



DIMENSION MATRIX

PRT NO.	CODE NO.	NO. OF CONTACT	f	g	h	j	k	m	n	p
FH23-15S-0.3SHW(05)	CL586-1317-0-05	15	16		7.5	7.3	5.1	4.5	17.4	21.4
FH23-17S-0.3SHW(05)	CL586-1300-7-05	17	16		7.5	7.9	5.7	5.1	17.4	21.4
FH23-21S-0.3SHW(05)	CL586-1314-1-05	21	16		7.5	9.1	6.9	6.3	17.4	21.4
FH23-23S-0.3SHW(05)	CL586-1324-5-05	23	24		11.5	9.7	7.5	6.9	25.4	29.4
FH23-25S-0.3SHW(05)	CL586-1322-0-05	25	24		11.5	10.3	8.1	7.5	25.4	29.4
FH23-27S-0.3SHW(05)	CL586-1308-9-05	27	24		11.5	10.9	8.7	8.1	25.4	29.4
FH23-31S-0.3SHW(05)	CL586-1302-2-05	31	24		11.5	12.1	9.9	9.3	25.4	29.4
FH23-33S-0.3SHW(05)	CL586-1304-8-05	33	24		11.5	12.7	10.5	9.9	25.4	29.4
FH23-37S-0.3SHW(05)	CL586-1335-1-05	37	24		11.5	13.9	11.7	11.1	25.4	29.4
FH23-39S-0.3SHW(05)	CL586-1306-3-05	39	24		11.5	14.5	12.3	11.7	25.4	29.4
FH23-45S-0.3SHW(05)	CL586-1318-2-05	45	24		11.5	16.3	14.1	13.5	25.4	29.4
FH23-51S-0.3SHW(06)	CL586-1312-6-06	51	32	28.4	14.2	18.1	15.9	15.3	33.4	37.4
FH23-61S-0.3SHW(05)	CL586-1310-0-05	61	32	28.4	14.2	21.1	18.9	18.3	33.4	37.4
FH23-71S-0.3SHW(05)	CL586-1320-4-05	71	44	40.4	20.2	24.1	21.9	21.3	45.4	49.4

2	POLYESTER		4	(CONNECTOR)	
1	POLYSTYRENE		3	POLYSTYRENE	
NO.	MATERIAL	FINISH . REMARKS	NO.	MATERIAL	FINISH . REMARKS
UNITS mm		SCALE 2 : 1	COUNT 11	DESCRIPTION OF REVISIONS DIS-F-002175	DESIGNED WR. YAMADA
APPROVED : MO. ISHIDA 05.01.05			CHECKED : SS. WATANABE 05.01.05		
DESIGNED : TO. SHIBUYA 05.01.05			DRAWN : TO. SHIBUYA 05.01.05		
DRAWING NO. EDC3-153547-03		PART NO. FH23-*S-0.3SHW(05)			
CODE NO. CL586		DATE 07.07.17			

Looking for pricing, stock, or lifecycle information?

Click below to explore more details on WIN SOURCE:

-  [View FH23-25S-0.3SHW\(05\) on WIN SOURCE](#)
-  [Hirose Electric Co Ltd Information](#)

Optimize Your Supply Chain with WIN SOURCE Solutions

-  Global Sourcing Solution
-  Obsolete Management
-  Cost Control Management
-  Shortage Management
-  Alternative Solution
-  Excess Inventory Management