



THE DATASHEET OF THS4221DBVR



LOW-DISTORTION, HIGH-SPEED, RAIL-TO-RAIL OUTPUT OPERATIONAL AMPLIFIERS

FEATURES

- **Rail-to-Rail Output Swing**
 - $V_O = -4.8/4.8$ ($R_L = 2\text{ k}\Omega$)
- **High Speed**
 - 230 MHz Bandwidth (-3 dB , $G = 1$)
 - 975 V/ μs Slew Rate
- **Ultra-Low Distortion**
 - HD2 = -90 dBc ($f = 5\text{ MHz}$, $R_L = 499\Omega$)
 - HD3 = -100 dBc ($f = 5\text{ MHz}$, $R_L = 499\Omega$)
- **High Output Drive, $I_O = 100\text{ mA}$ (typ)**
- **Excellent Video Performance**
 - 40 MHz Bandwidth (0.1 dB , $G = 2$)
 - 0.007% Differential Gain
 - 0.007° Differential Phase
- **Wide Range of Power Supplies**
 - $V_S = 3\text{ V}$ to 15 V
- **Power-Down Mode (THS4225/6)**
- **Evaluation Module Available**

DESCRIPTION

The THS4222 family is a set of rail-to-rail output single, and dual low-voltage, high-output swing, low-distortion high-speed amplifiers ideal for driving data converters, video switching or low distortion applications. This family of voltage feedback amplifiers can operate from a single 15-V power supply down to a single 3-V power supply while consuming only 14 mA of quiescent current per channel. In addition, the family offers excellent ac performance with 230-MHz bandwidth, 975-V/ μs slew rate and harmonic distortion (THD) at -90 dBc at 5 MHz.

APPLICATIONS

- **Low-Voltage Analog-to-Digital Converter Preamplifier**
- **Active Filtering**
- **Video Applications**

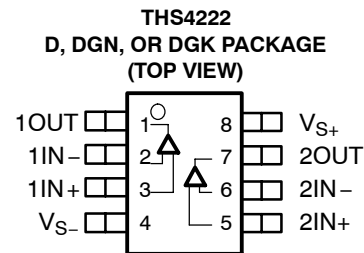

RELATED DEVICES

DEVICE	DESCRIPTION
THS4211	1 GHz, 800 V/ μs , $V_n = 7\text{ nV}/\sqrt{\text{Hz}}$
THS4271	1.4 GHz, 900 V/ μs , $V_n = 3\text{ nV}/\sqrt{\text{Hz}}$
OPA354	250 MHz, 150 V/ μs , $V_n = 6.5\text{ nV}/\sqrt{\text{Hz}}$
OPA690	500 MHz, 1800 V/ μs , $V_n = 5.5\text{ nV}/\sqrt{\text{Hz}}$

DIFFERENTIAL DRIVE CIRCUIT

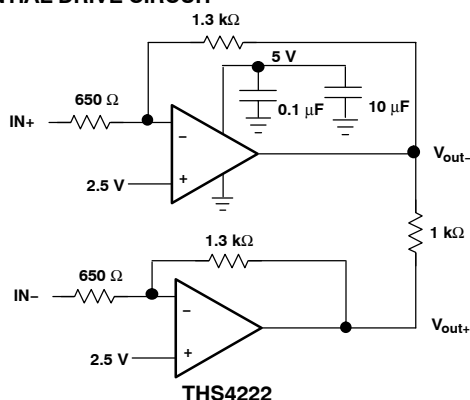

SLEW RATE

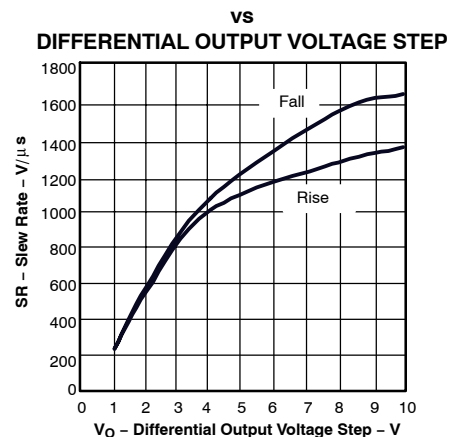

Please be aware that an important notice concerning availability, standard warranty, and use in critical applications of Texas Instruments semiconductor products and disclaimers thereto appears at the end of this data sheet.

ABSOLUTE MAXIMUM RATINGS

over operating free-air temperature range unless otherwise noted⁽¹⁾

		UNIT	
Supply voltage, V_S		16.5 V	
Input voltage, V_I		$\pm V_S$	
Output current, I_O		100 mA	
Differential input voltage, V_{ID}		4 V	
Continuous power dissipation		See Dissipation Rating Table	
Maximum junction temperature, T_J		150°C	
Maximum junction temperature, continuous operation, long term reliability T_J ⁽²⁾		125°C	
Storage temperature range, T_{stg}		-65°C to 150°C	
Lead temperature 1.6 mm (1/16 inch) from case for 10 seconds		300°C	
ESD ratings:	HBM	THS4221/5	2500 V
		THS4222/6	3000 V
	CDM		1500 V
	MM	THS4221/5	150 V
		THS4222/6	200 V

- (1) The absolute maximum ratings under any condition is limited by the constraints of the silicon process. Stresses above these ratings may cause permanent damage. Exposure to absolute maximum conditions for extended periods may degrade device reliability. These are stress ratings only, and functional operation of the device at these or any other conditions beyond those specified is not implied.
- (2) The maximum junction temperature for continuous operation is limited by package constraints. Operation above this temperature may result in reduced reliability and/or lifetime of the device.



This integrated circuit can be damaged by ESD. Texas Instruments recommends that all integrated circuits be handled with appropriate precautions. Failure to observe proper handling and installation procedures can cause damage.

ESD damage can range from subtle performance degradation to complete device failure. Precision integrated circuits may be more susceptible to damage because very small parametric changes could cause the device not to meet its published specifications.

PACKAGE DISSIPATION RATINGS

PACKAGE	Θ_{JC} (°C/W)	Θ_{JA} ⁽¹⁾ (°C/W)	POWER RATING ⁽²⁾	
			$T_A \leq 25^\circ\text{C}$	$T_A = 85^\circ\text{C}$
DBV (5)	55	255.4	391 mW	156 mW
D (8)	38.3	97.5	1.02 W	410 mW
DGN (8) ⁽³⁾	4.7	58.4	1.71 W	685 mW
DGK (8)	54.2	260	385 mW	154 mW
DGQ (10) ⁽³⁾	4.7	58	1.72 W	690 mW

- (1) This data was taken using the JEDEC standard High-K test PCB.
- (2) Power rating is determined with a junction temperature of 125°C. This is the point where distortion starts to substantially increase. Thermal management of the final PCB should strive to keep the junction temperature at or below 125°C for best performance and long term reliability.
- (3) The THS422x may incorporate a PowerPAD on the underside of the chip. This acts as a heatsink and must be connected to a thermally dissipative plane for proper power dissipation. Failure to do so may result in exceeding the maximum junction temperature which could permanently damage the device. See TI technical brief SLMA002 and SLMA004 for more information about utilizing the PowerPAD thermally enhanced package.

RECOMMENDED OPERATING CONDITIONS

		MIN	MAX	UNIT
Supply voltage, (V_{S+} and V_{S-})	Dual supply	± 1.35	± 7.5	V
	Single supply	2.7	15	
Input common-mode voltage range		$V_{S-} + 1.1$	$V_{S+} - 1.1$	V

THS4221 AND THS4225 SINGLE PACKAGE/ORDERING INFORMATION

PACKAGED DEVICES						
PLASTIC SMALL OUTLINE (D)	SOT-23 ⁽¹⁾		PLASTIC MSOP ⁽²⁾ PowerPAD™		PLASTIC MSOP ⁽²⁾	
	(DBV)	SYM	(DGN)	SYM	(DGK)	SYM
THS4221D	THS4221DBV	BFS	THS4221DGN	BFT	THS4221DGK	BHX
THS4225D	—	—	THS4225DGN	BFU	THS4225DGK	BFY

- (1) All packages are available taped and reeled. The R suffix standard quantity is 3000. The T suffix standard quantity is 250 (e.g., THS4221DBVT).
- (2) All packages are available taped and reeled. The R suffix standard quantity is 2500 (e.g., THS4221DGNR).

THS4222 AND THS4226 DUAL PACKAGE/ORDERING INFORMATION

PACKAGED DEVICES						
PLASTIC SMALL OUTLINE (D) ⁽¹⁾	PLASTIC MSOP PowerPAD™(1)				PLASTIC MSOP™(1)	
	(DGN)	SYM	(DGQ)	SYM	(DGK)	SYM
THS4222D	THS4222DGN	BFO	—	—	THS4222DGK	BHW
—	—	—	THS4226DGQ	BFP	—	—

(1) All packages are available taped and reeled. The R suffix standard quantity is 2500 (e.g., THS4222DGNR).

ELECTRICAL CHARACTERISTICS

$V_S = \pm 5\text{ V}$, $R_L = 499\ \Omega$, and $G = 1$ unless otherwise noted

PARAMETER	TEST CONDITIONS	TYP	OVER TEMPERATURE				UNITS	MIN/ MAX
		25°C	25°C	0°C to 70°C	-40°C to 85°C			
AC PERFORMANCE								
Small signal bandwidth	$G = 1$, $P_{IN} = -7\text{ dBm}$	230				MHz	Typ	
	$G = 2$, $P_{IN} = -13\text{ dBm}$, $R_f = 1.3\text{ k}\Omega$	100				MHz	Typ	
	$G = 5$, $P_{IN} = -21\text{ dBm}$, $R_f = 2\text{ k}\Omega$	25				MHz	Typ	
	$G = 10$, $P_{IN} = -27\text{ dBm}$, $R_f = 2\text{ k}\Omega$	12				MHz	Typ	
0.1 dB flat bandwidth	$G = 2$, $P_{IN} = -13\text{ dBm}$, $R_f = 1.3\text{ k}\Omega$	40				MHz	Typ	
Gain bandwidth product	$G > 10$, $f = 1\text{ MHz}$, $R_f = 2\text{ k}\Omega$	120				MHz	Typ	
Full-power bandwidth	$G = 1$, $V_O = \pm 2.5\text{ V}$	65				MHz	Typ	
Slew rate	$G = -1$, $V_O = \pm 2.5\text{ Vpp}$	990				V/ μs	Min	
	$G = 1$, $V_O = \pm 2.5\text{ Vpp}$	975				V/ μs	Min	
Settling time to 0.1%	$G = -1$, $V_O = \pm 2\text{ Vpp}$	25				ns	Typ	
Settling time to 0.01%	$G = -1$, $V_O = \pm 2\text{ Vpp}$	52				ns	Typ	
Harmonic distortion	$G = 1$, $V_O = 2\text{ Vpp}$, $f = 5\text{ MHz}$							
Second harmonic distortion	$R_L = 499\ \Omega$	-90				dBc	Typ	
	$R_L = 150\ \Omega$	-92				dBc	Typ	
Third harmonic distortion	$R_L = 499\ \Omega$	-100				dBc	Typ	
	$R_L = 150\ \Omega$	-96				dBc	Typ	
Differential gain (NTSC, PAL)	$G = 2$, $R = 150\ \Omega$	0.007				%	Typ	
Differential phase (NTSC, PAL)	$G = 2$, $R = 150\ \Omega$	0.007				°	Typ	
Input voltage noise	$f = 1\text{ MHz}$	13				nV/ $\sqrt{\text{Hz}}$	Typ	
Input current noise	$f = 1\text{ MHz}$	0.8				pA/ $\sqrt{\text{Hz}}$	Typ	
Crosstalk (dual only)	$f = 5\text{ MHz}$ Ch-to-Ch	-90				dB	Typ	
DC PERFORMANCE								
Open-loop voltage gain (A_{OL})	$V_O = \pm 2\text{ V}$	100	80	75	75	dB	Min	
Input offset voltage	$V_{CM} = 0\text{ V}$	3	10	16	16	mV	Max	
Average offset voltage drift	$V_{CM} = 0\text{ V}$			± 20	± 20	$\mu\text{V}/^\circ\text{C}$	Typ	
Input bias current	$V_{CM} = 0\text{ V}$	0.9	3	5	5	μA	Max	
Average offset voltage drift	$V_{CM} = 0\text{ V}$			± 10	± 10	$\mu\text{V}/^\circ\text{C}$	Typ	
Input offset current	$V_{CM} = 0\text{ V}$	100	500	700	700	nA	Max	
Average offset current drift	$V_{CM} = 0\text{ V}$			± 10	± 10	nA/ $^\circ\text{C}$	Typ	
INPUT CHARACTERISTICS								
Common-mode input range		-4 / 4	-3.9 / 3.9			V	Min	
Common-mode rejection ratio	$V_{CM} = \pm 2\text{ V}$	94	74	69	69	dB	Min	
Input resistance		33				M Ω	Typ	
Input capacitance	Common-mode / differential	1 / 0.5				pF	Max	

ELECTRICAL CHARACTERISTICS

$V_S = \pm 5\text{ V}$, $R_L = 499\ \Omega$, and $G = 1$ unless otherwise noted

PARAMETER	TEST CONDITIONS	TYP	OVER TEMPERATURE				UNITS	MIN/ MAX
		25°C	25°C	0°C to 70°C	-40°C to 85°C			
OUTPUT CHARACTERISTICS								
Output voltage swing	$R_L = 499\ \Omega$	-4.7 / 4.7	-4.5 / 4.5	-4.4 / 4.4	-4.4 / 4.4	V	Min	
	$R_L = 2\ \text{k}\Omega$	-4.8 / 4.8				V	Min	
Output current (sourcing)	$R_L = 10\ \Omega$	100	92	88	88	mA	Min	
Output current (sinking)	$R_L = 10\ \Omega$	-100	-92	-88	-88	mA	Min	
Output impedance	$f = 1\ \text{MHz}$	0.02				Ω	Typ	
POWER SUPPLY								
Specified operating voltage		± 5	± 7.5	± 7.5	± 7.5	V	Max	
Maximum quiescent current	Per channel	14	18	20	22	mA	Max	
Power supply rejection ($\pm\text{PSRR}$)		75	62	60	60	dB	Min	
POWER-DOWN CHARACTERISTICS								
Maximum power-down current	$\overline{\text{PD}} \leq \text{REF} + 1.0\ \text{V}$, $\text{REF} = 0\ \text{V}$, Per channel	700	900	1000	1000	μA	Max	
Power-down voltage level ⁽¹⁾	$\text{REF} = 0\ \text{V}$, or V_{S-}	Enable		REF+1.8		V	Min	
		Power down		REF+1		V	Max	
	$\text{REF} = V_{S+}$ or floating	Enable		REF-1		V	Min	
		Power down		REF-1.5		V	Max	
Turnon time delay	50% of final value	200				ns	Typ	
Turnoff time delay	50% of final value	500				ns	Typ	
Input impedance		58				Ω	Typ	
Isolation	$f = 5\ \text{MHz}$	80				dB	Typ	

⁽¹⁾ For detail information on the power-down circuit, refer to the powerdown section in the application information of this data sheet.

ELECTRICAL CHARACTERISTICS
 $V_S = 5\text{ V}$, $R_L = 499\ \Omega$, and $G = 1$ unless otherwise noted

PARAMETER	TEST CONDITIONS	TYP	OVER TEMPERATURE				UNITS	MIN/ MAX
		25°C	25°C	0°C to 70°C	-40°C to 85°C			
AC PERFORMANCE								
Small signal bandwidth	$G = 1$, $P_{IN} = -7\text{ dBm}$	200					MHz	Typ
	$G = 2$, $P_{IN} = -13\text{ dBm}$, $R_f = 1.3\text{ k}\Omega$	100					MHz	Typ
	$G = 5$, $P_{IN} = -21\text{ dBm}$, $R_f = 2\text{ k}\Omega$	25					MHz	Typ
	$G = 10$, $P_{IN} = -27\text{ dBm}$, $R_f = 2\text{ k}\Omega$	12					MHz	Typ
0.1 dB flat bandwidth	$G = 2$, $P_{IN} = -13\text{ dBm}$, $R_f = 1.3\text{ k}\Omega$	50					MHz	Typ
Gain bandwidth product	$G > 10$, $f = 1\text{ MHz}$, $R_f = 2\text{ k}\Omega$	120					MHz	Typ
Full-power bandwidth	$G = 1$, $V_O = \pm 2\text{ V}$	40					MHz	Typ
Slew rate	$G = -1$, $V_O = \pm 2\text{ Vpp}$	500					V/ μs	Min
	$G = 1$, $V_O = \pm 2\text{ Vpp}$	550					V/ μs	Min
Settling time to 0.1%	$G = -1$, $V_O = \pm 1\text{ Vpp}$	27					ns	Typ
Settling time to 0.01%	$G = -1$, $V_O = \pm 1\text{ Vpp}$	48					ns	Typ
Harmonic distortion	$G = 1$, $V_O = 2\text{ Vpp}$, $f = 5\text{ MHz}$							
Second harmonic distortion	$R_L = 499\ \Omega$	-90					dBc	Typ
	$R_L = 150\ \Omega$	-93					dBc	Typ
Third harmonic distortion	$R_L = 499\ \Omega$	-89					dBc	Typ
	$R_L = 150\ \Omega$	-91					dBc	Typ
Differential gain (NTSC, PAL)	$G = 2$, $R = 150\ \Omega$	0.014					%	Typ
Differential phase (NTSC, PAL)	$G = 2$, $R = 150\ \Omega$	0.011					°	Typ
Input voltage noise	$f = 1\text{ MHz}$	13					nV/ $\sqrt{\text{Hz}}$	Typ
Input current noise	$f = 1\text{ MHz}$	0.8					pA/ $\sqrt{\text{Hz}}$	Typ
Crosstalk (dual only)	$f = 5\text{ MHz}$ Ch-to-Ch	-90					dB	Typ
DC PERFORMANCE								
Open-loop voltage gain (A_{OL})	$V_O = 1.5\text{ V}$ to 3.5 V	100	80	75	75		dB	Min
Input offset voltage	$V_{CM} = 2.5\text{ V}$	3	10	16	16		mV	Max
Average offset voltage drift	$V_{CM} = 2.5\text{ V}$			± 20	± 20		$\mu\text{V}/^\circ\text{C}$	Typ
Input bias current	$V_{CM} = 2.5\text{ V}$	0.9	3	5	5		μA	Max
Average offset voltage drift	$V_{CM} = 2.5\text{ V}$			± 10	± 10		$\mu\text{V}/^\circ\text{C}$	Typ
Input offset current	$V_{CM} = 2.5\text{ V}$	100	500	700	700		nA	Max
Average offset current drift	$V_{CM} = 2.5\text{ V}$			± 10	± 10		nA/ $^\circ\text{C}$	Typ
INPUT CHARACTERISTICS								
Common-mode input range		1 / 4	1.1 / 3.9				V	Min
Common-mode rejection ratio	$V_{CM} = 1.5\text{ V}$ to 3.5 V	96	74	69	69		dB	Min
Input resistance		33					M Ω	Typ
Input capacitance	Common-mode / differential	1 / 0.5					pF	Max
OUTPUT CHARACTERISTICS								
Output voltage swing	$R_L = 499\ \Omega$	0.2 / 4.8	0.3 / 4.7	0.4 / 4.6	0.4 / 4.6		V	Min
	$R_L = 2\text{ k}\Omega$	0.1 / 4.9					V	Min
Output current (sourcing)	$R_L = 10\ \Omega$	95	85	80	80		mA	Min
Output current (sinking)	$R_L = 10\ \Omega$	-95	-85	-80	-80		mA	Min
Output impedance	$f = 1\text{ MHz}$	0.02					Ω	Typ

ELECTRICAL CHARACTERISTICS (continued)

$V_S = 5\text{ V}$, $R_L = 499\ \Omega$, and $G = 1$ unless otherwise noted

PARAMETER	TEST CONDITIONS	TYP	OVER TEMPERATURE				UNITS	MIN/ MAX
		25°C	25°C	0°C to 70°C	-40°C to 85°C			
POWER SUPPLY								
Specified operating voltage		5	15	15	15	V	Max	
Maximum quiescent current	Per channel	12	15	17	19	mA	Max	
Power supply rejection (\pm PSRR)		70	62	60	60	dB	Min	
POWER-DOWN CHARACTERISTICS								
Maximum power-down current	$\overline{PD} \leq \text{REF} + 1.0\text{ V}$, $\text{REF} = 0\text{ V}$, Per channel	500	750	900	900	μA	Max	
Power-down voltage level ⁽¹⁾	REF = 0 V, or V_{S-}	Enable		REF+1.8		V	Min	
		Power down		REF+1		V	Max	
	REF = V_{S+} or floating	Enable		REF-1		V	Min	
		Power down		REF-1.5		V	Max	
Turnon time delay	50% of final value	200				ns	Typ	
Turnoff time delay	50% of final value	500				ns	Typ	
Input impedance		58				Ω	Typ	
Isolation	f = 5 MHz	80				dB	Typ	

⁽¹⁾ For detail information on the power-down circuit, refer to the powerdown section in the application information of this data sheet.

ELECTRICAL CHARACTERISTICS
 $V_S = 3.3\text{ V}$, $R_L = 499\ \Omega$, and $G = 1$ unless otherwise noted

PARAMETER	TEST CONDITIONS	TYP	OVER TEMPERATURE				UNITS	MIN/ MAX
		25°C	25°C	0°C to 70°C	-40°C to 85°C			
AC PERFORMANCE								
Small signal bandwidth	$G = 1$, $P_{IN} = -7\text{ dBm}$	200					MHz	Typ
	$G = 2$, $P_{IN} = -13\text{ dBm}$, $R_f = 1\text{ k}\Omega$	100					MHz	Typ
	$G = 5$, $P_{IN} = -21\text{ dBm}$, $R_f = 2\text{ k}\Omega$	15					MHz	Typ
	$G = 10$, $P_{IN} = -27\text{ dBm}$, $R_f = 2\text{ k}\Omega$	12					MHz	Typ
0.1 dB flat bandwidth	$G = 2$, $P_{IN} = -13\text{ dBm}$, $R_f = 1\text{ k}\Omega$	50					MHz	Typ
Gain bandwidth product	$G > 10$, $f = 1\text{ MHz}$, $R_f = 1.5\text{ k}\Omega$	120					MHz	Typ
Full-power bandwidth	$G = 1$, $V_O = 1.3\text{ V to } 2\text{ V}$	50					MHz	Typ
Slew rate	$G = -1$, $V_O = 1.3\text{ V to } 2\text{ V}$	120					V/ μs	Min
	$G = 1$, $V_O = 1.3\text{ V to } 2\text{ V}$	250					V/ μs	Min
Harmonic distortion	$G = 2$, $V_O = 1\text{ V}_{pp}$, $f = 5\text{ MHz}$							
Second harmonic distortion	$R_L = 499\ \Omega$	-80					dBc	Typ
	$R_L = 150\ \Omega$	-79					dBc	Typ
Third harmonic distortion	$R_L = 499\ \Omega$	-91					dBc	Typ
	$R_L = 150\ \Omega$	-92					dBc	Typ
Input voltage noise	$f = 1\text{ MHz}$	13					nV/ $\sqrt{\text{Hz}}$	Typ
Input current noise	$f = 1\text{ MHz}$	0.8					pA/ $\sqrt{\text{Hz}}$	Typ
Crosstalk (dual only)	$f = 5\text{ MHz Ch-to-Ch}$	-90					dB	Typ
DC PERFORMANCE								
Open-loop voltage gain (A_{OL})	$V_O = 1.35\text{ V to } 1.95\text{ V}$	98	80	75	75		dB	Min
Input offset voltage	$V_{CM} = 1.65\text{ V}$	3	10	16	16		mV	Max
Average offset voltage drift	$V_{CM} = 1.65\text{ V}$			± 20	± 20		$\mu\text{V}/^\circ\text{C}$	Typ
Input bias current	$V_{CM} = 1.65\text{ V}$	0.9	3	5	5		μA	Max
Average offset voltage drift	$V_{CM} = 1.65\text{ V}$			± 10	± 10		$\mu\text{V}/^\circ\text{C}$	Typ
Input offset current	$V_{CM} = 1.65\text{ V}$	100	500	700	700		nA	Max
Average offset current drift	$V_{CM} = 1.65\text{ V}$			± 10	± 10		nA/ $^\circ\text{C}$	Typ
INPUT CHARACTERISTICS								
Common-mode input range		1 / 2.3	1.1/2.2				V	Min
Common-mode rejection ratio	$V_{CM} = 1.35\text{ V to } 1.95\text{ V}$	92	74	69	69		dB	Min
Input resistance		33					M Ω	Typ
Input capacitance	Common-mode / differential	1 / 0.5					pF	Max
OUTPUT CHARACTERISTICS								
Output voltage swing	$R_L = 499\ \Omega$	0.15/3.15	0.3/3.0	0.35/2.95	0.35/2.95		V	Min
Output voltage swing	$R_L = 2\text{ k}\Omega$	0.1 / 3.2					V	Min
Output current (sourcing)	$R_L = 20\ \Omega$	50	45	40	40		mA	Min
Output current (sinking)	$R_L = 20\ \Omega$	-50	-45	-40	-40		mA	Min
Output impedance	$f = 1\text{ MHz}$	0.02					Ω	Typ

ELECTRICAL CHARACTERISTICS (continued)

$V_S = 3.3\text{ V}$, $R_L = 499\ \Omega$, and $G = 1$ unless otherwise noted

PARAMETER	TEST CONDITIONS	TYP	OVER TEMPERATURE				UNITS	MIN/ MAX
		25°C	25°C	0°C to 70°C	-40°C to 85°C			
POWER SUPPLY								
Specified operating voltage		3.3	15	15	15	V	Max	
Maximum quiescent current	Per channel	11	13	16	17	mA	Max	
Power supply rejection (\pm PSRR)		65	60	55	55	dB	Min	
POWER-DOWN CHARACTERISTICS								
Maximum power-down current	$\overline{PD} \leq \text{REF} + 1.0\text{ V}$, $\text{REF} = 0\text{ V}$, Per channel	500	700	800	800	μA	Max	
Power-down voltage level ⁽¹⁾	$\text{REF} = 0\text{ V}$, or V_{S-}	Enable		REF+1.8		V	Min	
		Power down		REF+1		V	Max	
	$\text{REF} = V_{S+}$ or floating	Enable		REF-1		V	Min	
		Power down		REF-1.5		V	Max	
Turnon time delay	50% of final value	200				ns	Typ	
Turnoff time delay	50% of final value	500				ns	Typ	
Input impedance		58				Ω	Typ	
Isolation	$f = 5\text{ MHz}$	80				dB	Typ	

⁽¹⁾ For detail information on the power-down circuit, refer to the powerdown section in the application information of this data sheet.

PIN ASSIGNMENTS

NON-POWER DOWN PACKAGE DEVICES

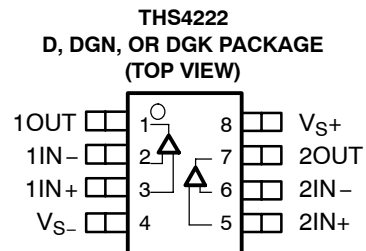
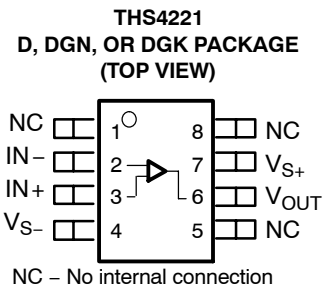
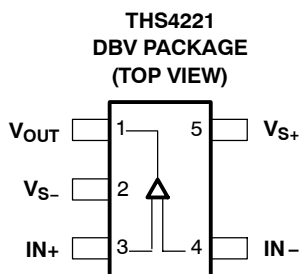

POWER-DOWN PACKAGE DEVICES

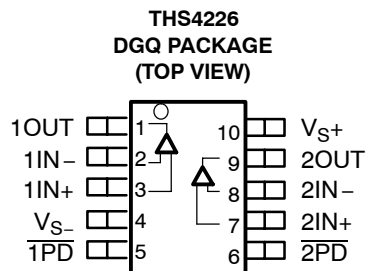
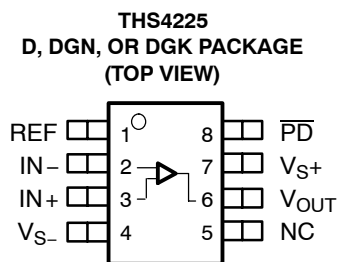

NC – No internal connection

TYPICAL CHARACTERISTICS

TABLE OF GRAPHS

	FIGURE
Small signal frequency response	1
Slew rate vs Output voltage step	2, 3
Harmonic distortion vs Frequency	4, 5, 8, 9
Harmonic distortion vs Output voltage swing	6, 7
Voltage and current noise vs Frequency	10
Differential gain vs Number of loads	11, 13
Differential phase vs Number of loads	12, 14
Quiescent current vs Supply voltage	15
Output voltage vs Load resistance	16
Open-loop gain and phase vs Frequency	17
Open-loop gain vs Supply voltage	18
Rejection ratio vs Frequency	19
Rejection ratio vs Case temperature	20
Common-mode rejection ratio vs Input common-mode range	21, 22
Input offset voltage vs Case temperature	23
Input bias and offset current vs Case temperature	24, 25
Power-down quiescent current vs Supply voltage	26
Output impedance in power down vs Frequency	27
Crosstalk vs Frequency	28

SMALL SIGNAL FREQUENCY RESPONSE

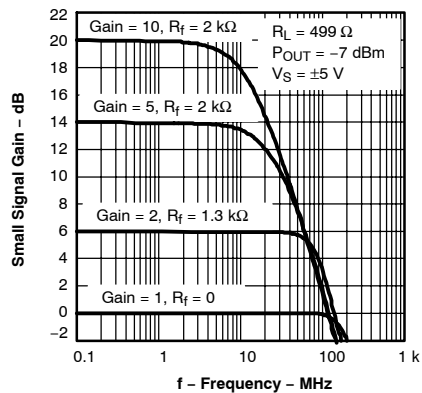

Figure 1

SLEW RATE
vs
OUTPUT VOLTAGE STEP

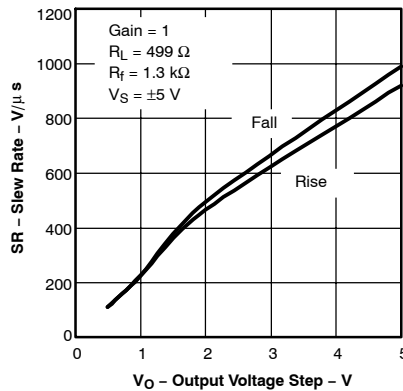

Figure 2

SLEW RATE
vs
OUTPUT VOLTAGE STEP

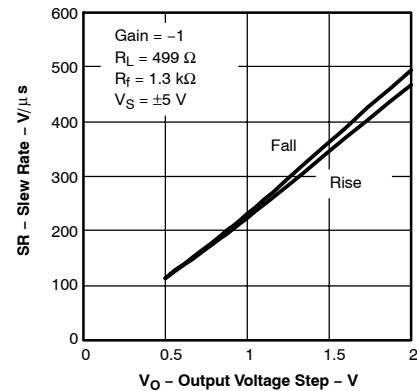

Figure 3

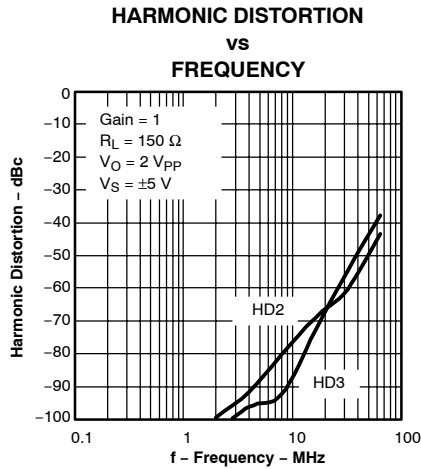

Figure 4

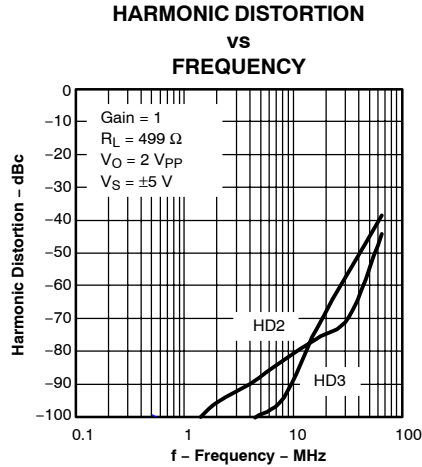

Figure 5

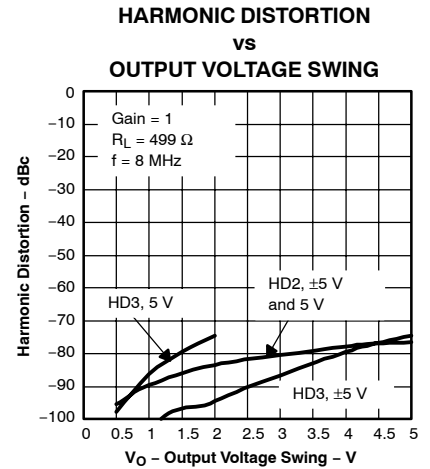

Figure 6

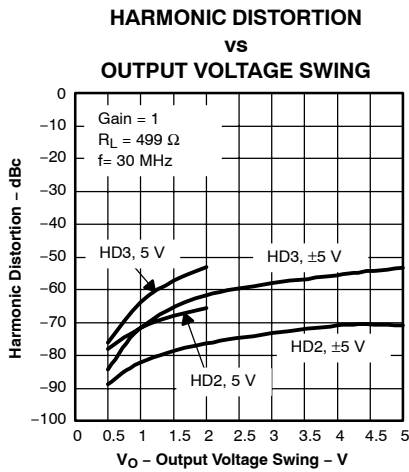

Figure 7

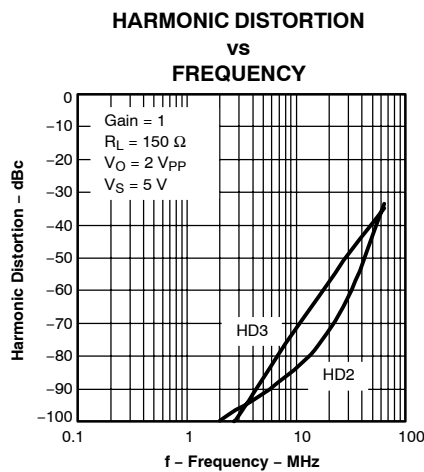

Figure 8

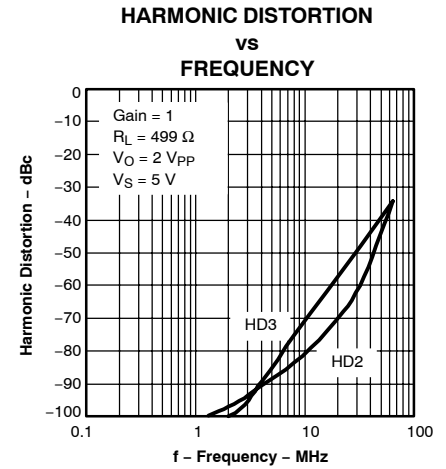

Figure 9

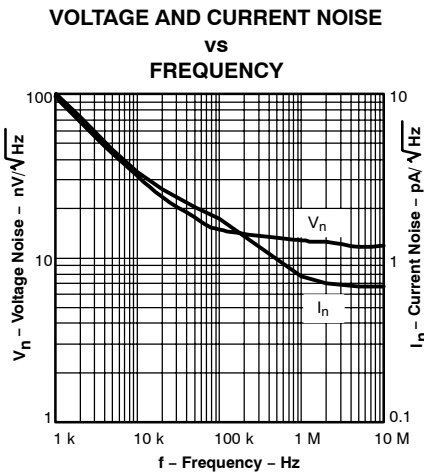

Figure 10

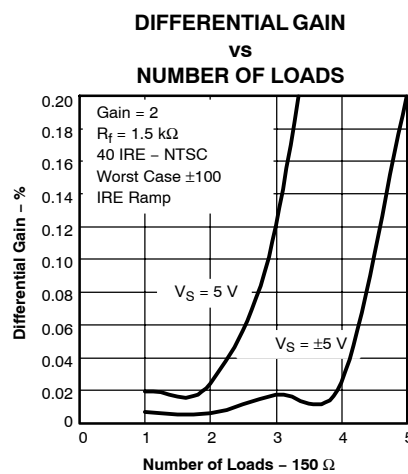

Figure 11

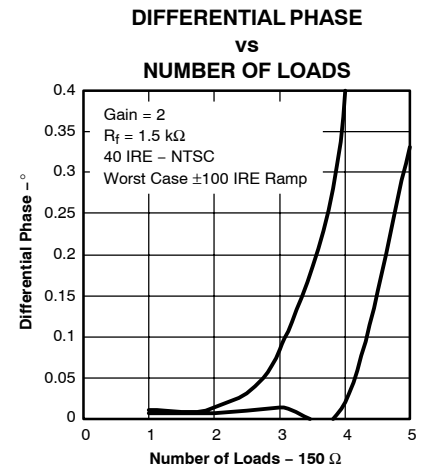

Figure 12

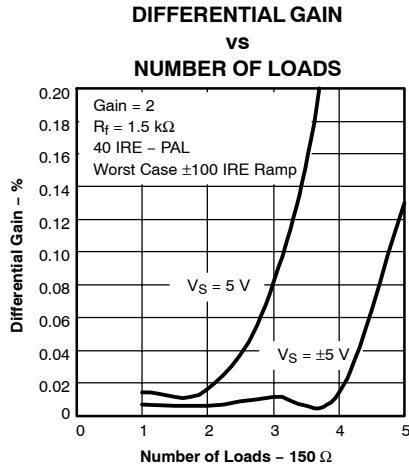

Figure 13

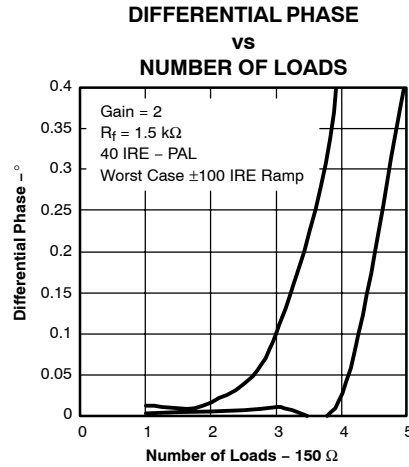

Figure 14

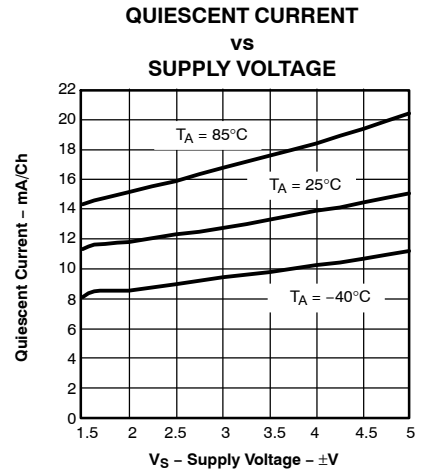

Figure 15

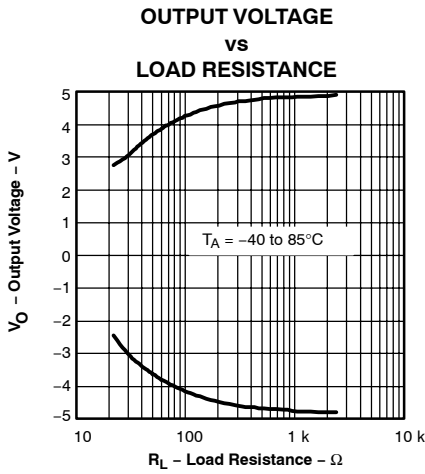

Figure 16

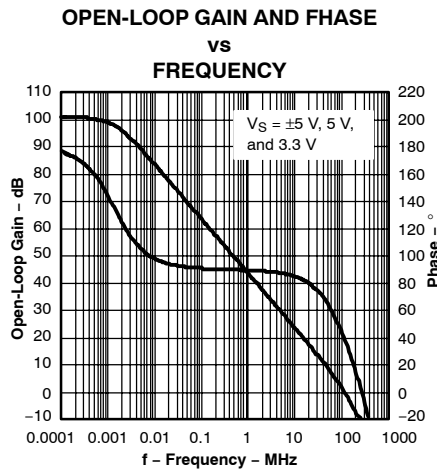

Figure 17

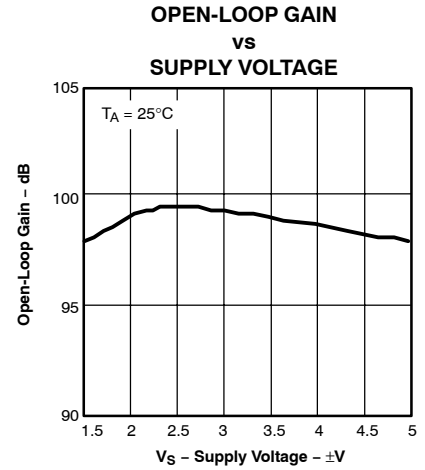

Figure 18

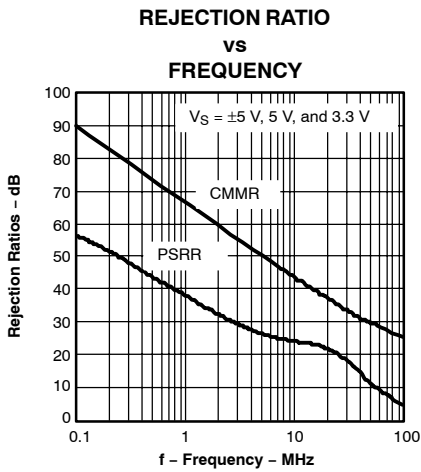

Figure 19

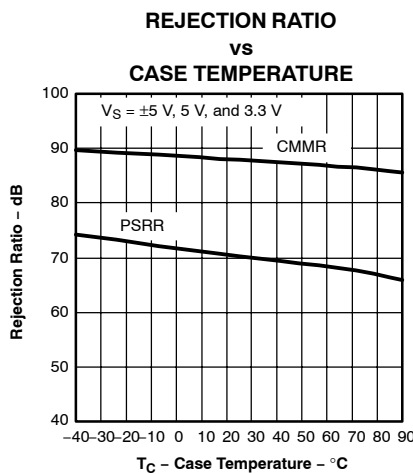

Figure 20

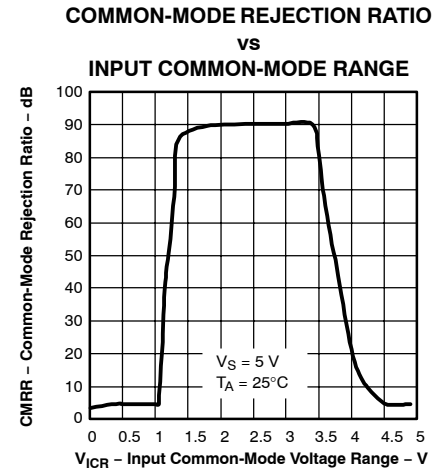

Figure 21

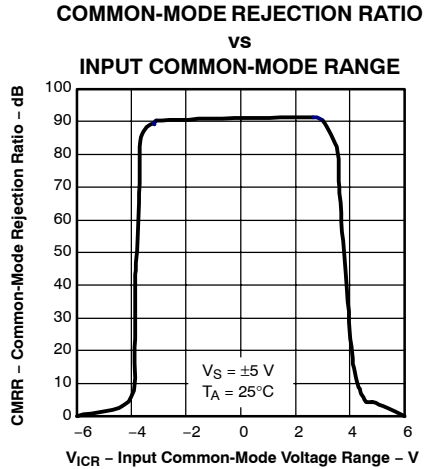

Figure 22

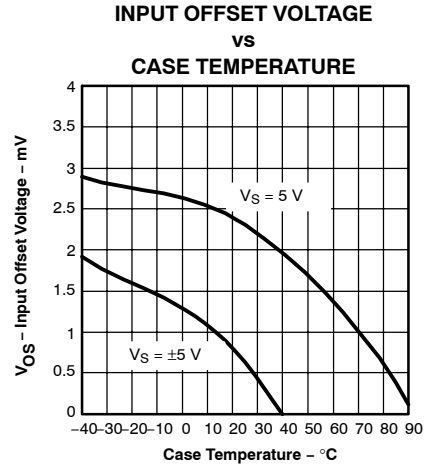

Figure 23

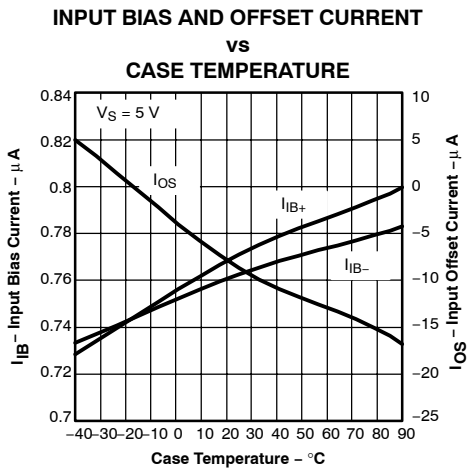

Figure 24

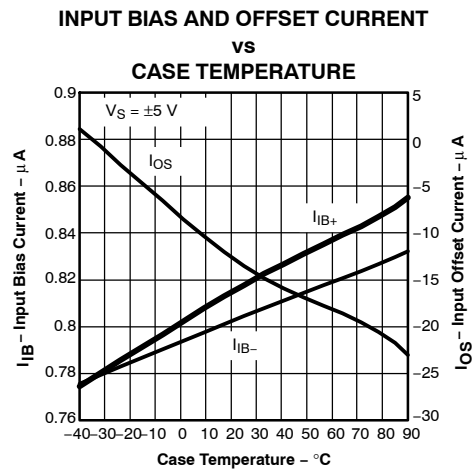

Figure 25

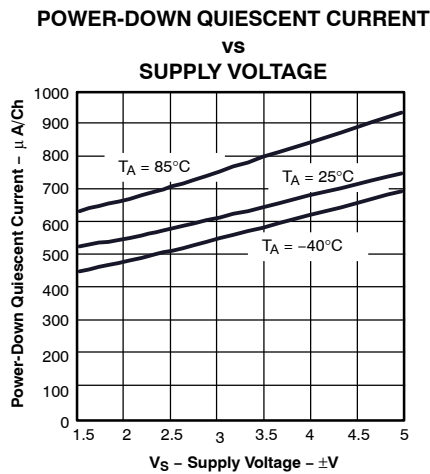

Figure 26

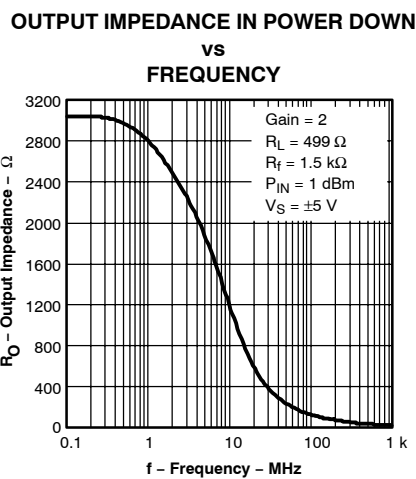

Figure 27

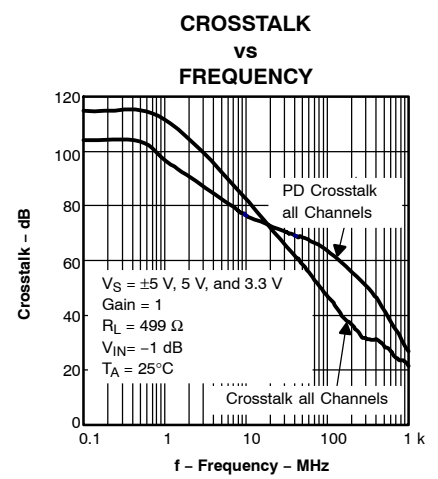

Figure 28

APPLICATION INFORMATION

HIGH-SPEED OPERATIONAL AMPLIFIERS

The THS4222 family of operational amplifiers is a family of single and dual, rail-to-rail output voltage feedback amplifiers. The THS4222 family combines both a high slew rate and a rail-to-rail output stage.

The THS4225 and THS4226 provides a power-down mode, providing the ability to save power when the amplifier is inactive. A reference pin is provided to allow the user the flexibility to control the threshold levels of the power-down control pin.

Applications Section Contents

- Wideband, Noninverting Operation
- Wideband, Inverting Gain Operation
- Single Supply Operation
- Saving Power With Power-Down Functionality and Setting Threshold Levels With the Reference Pin
- Power Supply Decoupling Techniques and Recommendations
- Driving an ADC With the THS4222
- Active Filtering With the THS4222
- An Abbreviated Analysis of Noise in Amplifiers
- Driving Capacitive Loads
- Printed Circuit Board Layout Techniques for Optimal Performance
- Power Dissipation and Thermal Considerations
- Evaluation Fixtures, Spice Models, and Applications Support
- Additional Reference Material
- Mechanical Package Drawings

WIDEBAND, NONINVERTING OPERATION

The THS4222 is a family of unity gain stable rail-to-rail output voltage feedback operational amplifiers, with and without power-down capability, designed to operate from a single 3-V to 15-V power supply.

Figure 29 is the noninverting gain configuration of 2 V/V used to demonstrate the typical performance curves.

Voltage feedback amplifiers, unlike current feedback designs, can use a wide range of resistors values to set their gain with minimal impact on their stability and frequency response. Larger-valued resistors decrease the loading effect of the feedback network on the output of the amplifier, but this enhancement comes at the expense of additional noise and potentially lower bandwidth. Feedback resistor values between 1 k Ω and 2 k Ω are recommended for most situations.

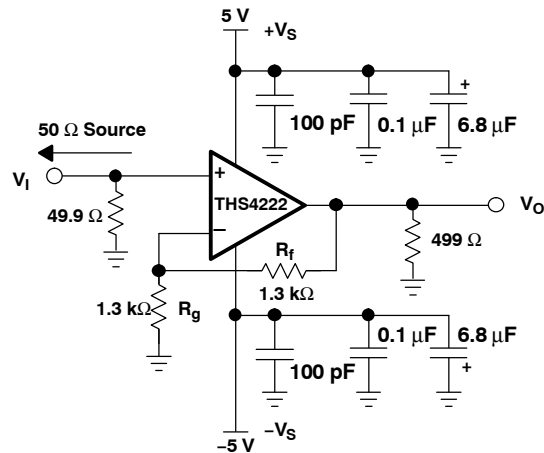

Figure 29. Wideband, Noninverting Gain Configuration

WIDEBAND, INVERTING OPERATION

Since the THS4222 family are general-purpose, wideband voltage-feedback amplifiers, several familiar operational amplifier applications circuits are available to the designer. Figure 30 shows a typical inverting configuration where the input and output impedances and noise gain from Figure 29 are retained in an inverting circuit configuration. Inverting operation is one of the more common requirements and offers several performance benefits. The inverting configuration shows improved slew rates and distortion due to the pseudo-static voltage maintained on the inverting input.

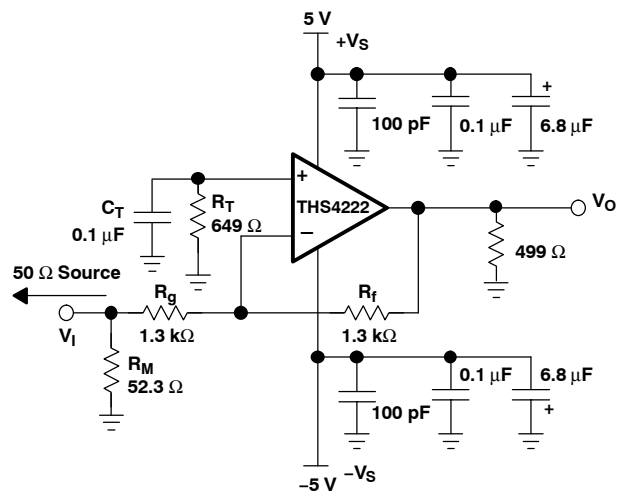

Figure 30. Wideband, Inverting Gain Configuration

In the inverting configuration, some key design considerations must be noted. One is that the gain resistor (R_g) becomes part of the signal channel input impedance. If the input impedance matching is desired (which is beneficial whenever the signal is coupled through a cable, twisted pair, long PC board trace, or other transmission line conductors), R_g may be set equal to the required termination value and R_f adjusted to give the desired gain. However, care must be taken when dealing with low inverting gains, as the resultant feedback resistor value can present a significant load to the amplifier output. For an inverting gain of 2, setting R_g to $49.9\ \Omega$ for input matching eliminates the need for R_M but requires a $100\text{-}\Omega$ feedback resistor. This has an advantage of the noise gain becoming equal to 2 for a $50\text{-}\Omega$ source impedance—the same as the noninverting circuit in Figure 29. However, the amplifier output now sees the $100\text{-}\Omega$ feedback resistor in parallel with the external load. To eliminate this excessive loading, it is preferable to increase both R_g and R_f values, as shown in Figure 30, and then achieve the input matching impedance with a third resistor (R_M) to ground. The total input impedance becomes the parallel combination of R_g and R_M .

The last major consideration to discuss in inverting amplifier design is setting the bias current cancellation resistor on the noninverting input. If the resistance is set equal to the total dc resistance looking out of the inverting terminal, the output dc error, due to the input bias currents, is reduced to (input offset current) multiplied by R_f in Figure 30, the dc source impedance looking out of the inverting terminal is $1.3\ \text{k}\Omega \parallel (1.3\ \text{k}\Omega + 25.6\ \Omega) = 649\ \Omega$. To reduce the additional high-frequency noise introduced by the resistor at the noninverting input, and power-supply feedback, R_T is bypassed with a capacitor to ground.

SINGLE SUPPLY OPERATION

The THS4222 is designed to operate from a single 3-V to 15-V power supply. When operating from a single power supply, care must be taken to ensure the input signal and amplifier are biased appropriately to allow for the maximum output voltage swing. The circuits shown in Figure 31 demonstrate methods to configure an amplifier in a manner conducive for single supply operation.

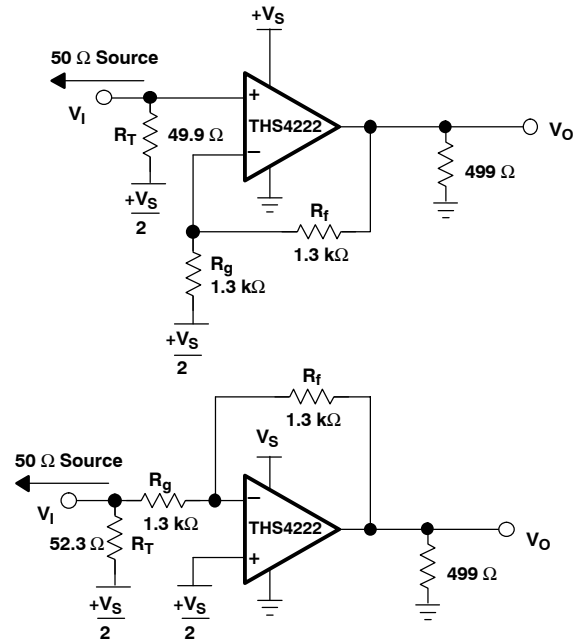

Figure 31. DC-Coupled Single Supply Operation
Saving Power With Power-Down Functionality
and Setting Threshold Levels With the Reference Pin

The THS4225 and THS4226 feature a power-down pin ($\overline{\text{PD}}$) which lowers the quiescent current from $14\ \text{mA}/\text{ch}$ down to $700\ \mu\text{A}/\text{ch}$, ideal for reducing system power.

The power-down pin of the amplifiers defaults to the positive supply voltage in the absence of an applied voltage, putting the amplifier in the *power-on* mode of operation. To turn off the amplifier in an effort to conserve power, the power-down pin can be driven towards the negative rail. The threshold voltages for power-on and power-down are relative to the supply rails and given in the specification tables. Above the *Enable Threshold Voltage*, the device is on. Below the *Disable Threshold Voltage*, the device is off. Behavior in between these threshold voltages is not specified.

Note that this power-down functionality is just that; the amplifier consumes less power in power-down mode. The power-down mode is not intended to provide a high-impedance output. In other words, the power-down functionality is not intended to allow use as a 3-state bus driver. When in power-down mode, the impedance looking back into the output of the amplifier is dominated by the feedback and gain setting resistors, but the output impedance of the device itself varies depending on the voltage applied to the outputs.

The time delays associated with turning the device on and off are specified as the time it takes for the amplifier to reach 50% of the nominal quiescent current. The time delays are on the order of microseconds because the amplifier moves in and out of the linear mode of operation in these transitions.

Power-Down Reference Pin Operation

In addition to the power-down pin, the THS4225 features a reference pin (REF) which allows the user to control the enable or disable power-down voltage levels applied to the $\overline{\text{PD}}$ pin. Operation of the reference pin as it relates to the power-down pin is described below.

In most split-supply applications, the reference pin is connected to ground. In some cases, the user may want to connect it to the negative or positive supply rail. In either case, the user needs to be aware of the voltage level thresholds that apply to the power-down pin. The tables below show examples and illustrate the relationship between the reference voltage and the power-down thresholds.

POWER-DOWN THRESHOLD VOLTAGE LEVELS (REF \leq Midrail)			
SUPPLY VOLTAGE (V)	REFERENCE PIN VOLTAGE (V)	ENABLE LEVEL (V)	DISABLE LEVEL (V)
± 5	GND	≥ 1.8	≤ 1
	-2.5	≥ -0.7	≤ -1.5
	-5	≥ -3.2	≤ -4
5	GND	≥ 1.8	≤ 1
	1	≥ 2.8	≤ 2
	2.5	≥ 4.3	≤ 3.5
3.3	GND	≥ 1.8	≤ 1

In the above table, the threshold levels are derived by the following equations:

$$\text{REF} + 1.8 \text{ V for enable}$$

$$\text{REF} + 1 \text{ V for disable}$$

Note that in order to maintain these threshold levels, the reference pin can be any voltage between V_{s-} or GND up to $V_{s+}/2$ (mid rail).

For 3.3-V operation, the reference pin must be connected to the most negative rail (for single supply this is GND).

POWER-DOWN THRESHOLD VOLTAGE LEVELS (REF $>$ Midrail)			
SUPPLY VOLTAGE (V)	REFERENCE PIN VOLTAGE (V)	ENABLE LEVEL (V)	DISABLE LEVEL (V)
± 5	Floating or 5	≥ 4	≤ 3.5
	2.5	≥ 1.5	≤ 1
	1	≥ 0	≤ -0.5
5	Floating or 5	≥ 4	≤ 3.5
	4	≥ 3	≤ 2.5
	3.5	≥ 2.5	≤ 2
3.3	Floating or 3.3	≥ 2.7	≤ 1.8

In the above table, the threshold levels are derived by the following equations:

$$\text{REF} - 1 \text{ V for enable}$$

$$\text{REF} - 1.5 \text{ V for disable}$$

Note that in order to maintain these threshold levels, the reference pin can be any voltage between $(V_{s+}/2) + 1 \text{ V}$ to V_{s+} or left floating. The reference pin is internally connected to the positive rail, therefore it can be left floating to maintain these threshold levels.

For 3.3-V operation, the reference pin must be connected to the positive rail or left floating.

The recommended mode of operation is to tie the reference pin to midrail, thus setting the threshold levels to midrail +1.0 V and midrail +1.8 V.

NO. OF CHANNELS	PACKAGES
Single (8-pin)	THS4225D, THS4225DGN

Power Supply Decoupling Techniques and Recommendations

Power supply decoupling is a critical aspect of any high-performance amplifier design process. Careful decoupling provides higher quality ac performance (most notably improved distortion performance). The following guidelines ensure the highest level of performance.

1. Place decoupling capacitors as close to the power supply inputs as possible, with the goal of minimizing the inductance of the path from ground to the power supply.
2. Placement priority should put the smallest valued capacitors closest to the device.
3. Use of solid power and ground planes is recommended to reduce the inductance along power supply return current paths, with the exception of the areas underneath the input and output pins.
4. Recommended values for power supply decoupling include a bulk decoupling capacitor (6.8 to 22 μF), a mid-range decoupling capacitor (0.1 μF) and a high frequency decoupling capacitor (1000 pF) for each supply. A 100 pF capacitor can be used across the supplies as well for extremely high frequency return currents, but often is not required.

APPLICATION CIRCUITS

Driving an Analog-to-Digital Converter With the THS4222

The THS4222 can be used to drive high-performance analog-to-digital converters. Two example circuits are presented below.

The first circuit uses a wideband transformer to convert a single-ended input signal into a differential signal. The differential signal is then amplified and filtered by two THS4222 amplifiers. This circuit provides low intermodulation distortion, suppressed even-order distortion, 14 dB of voltage gain, a 50- Ω input impedance, and a single-pole filter at 25 MHz. For applications without signal content at dc, this method of driving ADCs can be very useful. Where dc information content is required, the THS4500 family of fully differential amplifiers may be applicable.

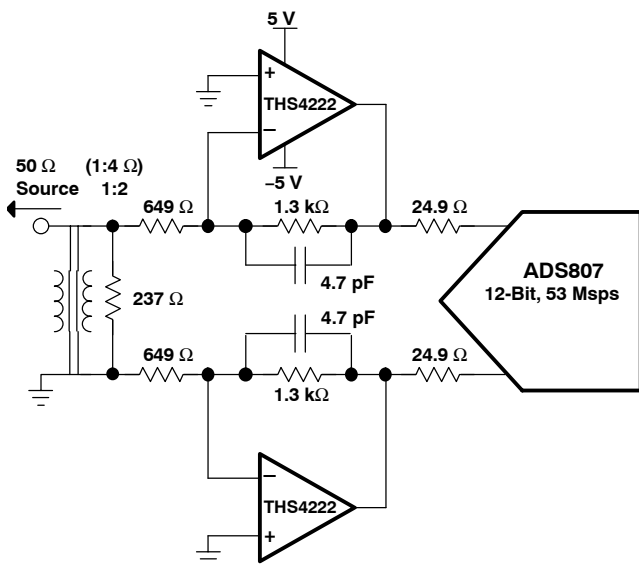
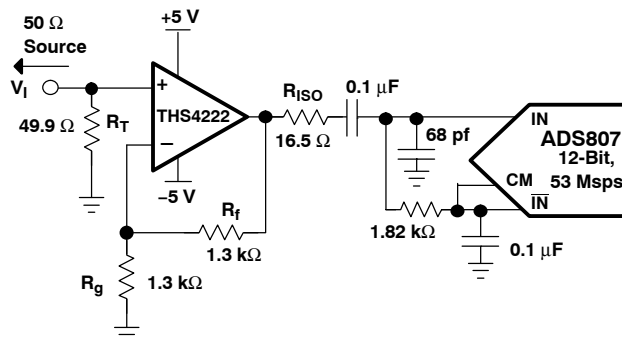

Figure 32. A Linear, Low Noise, High Gain ADC Preamplifier

The second circuit depicts single-ended ADC drive. While not recommended for optimum performance using converters with differential inputs, satisfactory

performance can sometimes be achieved with single-ended input drive. An example circuit is shown here for reference.



NOTE: For best performance, high-speed ADCs should be driven differentially. See the THS4500 family of devices for more information.

Figure 33. Driving an ADC With a Single-Ended Input

Active Filtering With the THS4222

High-frequency active filtering with the THS4222 is achievable due to the amplifier's high slew rate, wide bandwidth, and voltage feedback architecture. Several options are available for high-pass, low-pass, bandpass, and bandstop filters of varying orders. A simple two-pole low pass filter is presented here as an example, with two poles at about 25 MHz.

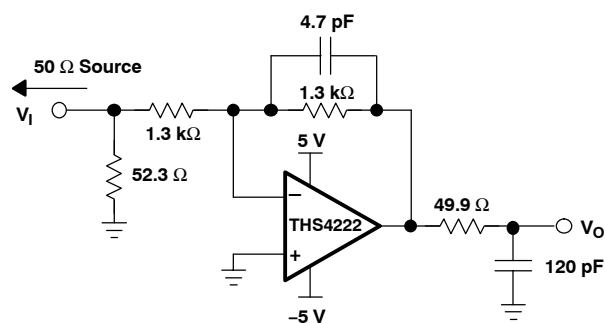

Figure 34. A Two-Pole Active Filter With Two Poles at about 25 MHz

NOISE ANALYSIS

High slew rates, stable unity gain, voltage-feedback operational amplifiers usually achieve their slew rate at the expense of a higher input noise voltage. The input-referred voltage noise, and the two input-referred current noise terms, combine to give low output noise under a wide variety of operating conditions. Figure 35 shows the amplifier noise analysis model with all the noise terms included. In this model, all noise terms are taken to be noise voltage or current density terms in either nV/\sqrt{Hz} or pA/\sqrt{Hz} .

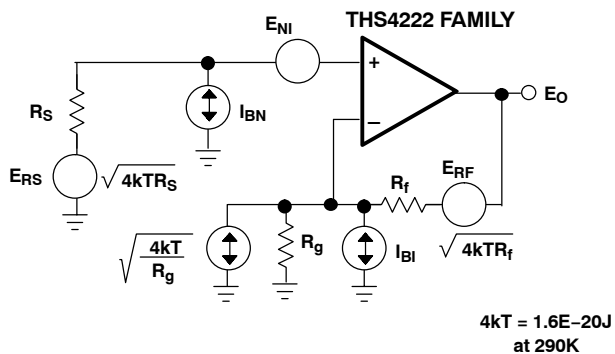

Figure 35. Noise Analysis Model

The total output shot noise voltage can be computed as the square of all squares output noise voltage contributors. Equation 1 shows the general form for the output noise voltage using the terms shown in Figure 35:

$$E_O = \sqrt{\left(E_{NI}^2 + (I_{BN}R_S)^2 + 4kTR_S\right)NG^2 + (I_{BI}R_f)^2 + 4kTR_f}NG$$

Dividing this expression by the noise gain ($NG=(1+R_f/R_g)$) gives the equivalent input-referred spot noise voltage at the noninverting input, as shown in equation 2:

$$E_O = \sqrt{E_{NI}^2 + (I_{BN}R_S)^2 + 4kTR_S + \left(\frac{I_{BI}R_f}{NG}\right)^2 + \frac{4kTR_f}{NG}}$$

Driving Capacitive Loads

One of the most demanding, and yet very common, load conditions for an op amp is capacitive loading. Often, the capacitive load is the input of an A/D converter, including additional external capacitance, which may be recommended to improve A/D linearity. A high-speed, high open-loop gain amplifier like the THS4222 can be very susceptible to decreased stability and closed-loop response peaking when a capacitive load is placed directly on the output pin. When the amplifier's open-loop output resistance is considered, this capacitive load introduces an additional pole in the signal path that can decrease the phase margin. When the primary considerations are frequency response flatness, pulse response fidelity, or

distortion, the simplest and most effective solution is to isolate the capacitive load from the feedback loop by inserting a series isolation resistor between the amplifier output and the capacitive load. This does not eliminate the pole from the loop response, but rather shifts it and adds a zero at a higher frequency. The additional zero acts to cancel the phase lag from the capacitive load pole, thus increasing the phase margin and improving stability.

BOARD LAYOUT

Achieving optimum performance with a high frequency amplifier like the THS4222 requires careful attention to board layout parasitics and external component types.

Recommendations that optimize performance include:

1. **Minimize parasitic capacitance to any ac ground for all of the signal I/O pins.** Parasitic capacitance on the output and inverting input pins can cause instability: on the noninverting input, it can react with the source impedance to cause unintentional band limiting. To reduce unwanted capacitance, a window around the signal I/O pins should be opened in all of the ground and power planes around those pins. Otherwise, ground and power planes should be unbroken elsewhere on the board.
2. **Minimize the distance (< 0.25") from the power supply pins to high frequency 0.1-μF decoupling capacitors.** At the device pins, the ground and power plane layout should not be in close proximity to the signal I/O pins. Avoid narrow power and ground traces to minimize inductance between the pins and the decoupling capacitors. The power supply connections should always be decoupled with these capacitors. Larger (2.2-μF to 6.8-μF) decoupling capacitors, effective at lower frequency, should also be used on the main supply pins. These may be placed somewhat farther from the device and may be shared among several devices in the same area of the PC board.
3. **Careful selection and placement of external components will preserve the high frequency performance of the THS4222.** Resistors should be a very low reactance type. Surface-mount resistors work best and allow a tighter overall layout. Metal-film and carbon composition, axially-leaded resistors can also provide good high frequency performance. Again, keep their leads and PC board trace length as short as possible. Never use wire wound type resistors in a high frequency application. Since the output pin and inverting input pin are the most sensitive to parasitic capacitance, always position the feedback and series output resistor, if any, as close as possible to the output pin. Other network components, such as noninverting input termination resistors, should also be placed close to the package. Where double-side component mounting is allowed, place

the feedback resistor directly under the package on the other side of the board between the output and inverting input pins. Even with a low parasitic capacitance shunting the external resistors, excessively high resistor values can create significant time constants that can degrade performance. Good axial metal-film or surface-mount resistors have approximately 0.2 pF in shunt with the resistor. For resistor values > 2.0 kΩ, this parasitic capacitance can add a pole and/or a zero below 400 MHz that can effect circuit operation. Keep resistor values as low as possible, consistent with load driving considerations. It has been suggested here that a good starting point for design would be set the R_f be set to 1.3 kΩ for low-gain, noninverting applications. Doing this automatically keeps the resistor noise terms low, and minimize the effect of their parasitic capacitance.

- Connections to other wideband devices on the board may be made with short direct traces or through onboard transmission lines.** For short connections, consider the trace and the input to the next device as a lumped capacitive load. Relatively wide traces (50 mils to 100 mils) should be used, preferably with ground and power planes opened up around them. Estimate the total capacitive load and set R_{ISO} from the plot of recommended R_{ISO} vs Capacitive Load. Low parasitic capacitive loads (<4 pF) may not need an R_{ISO} , since the THS4222 is nominally compensated to operate with a 2-pF parasitic load. Higher parasitic capacitive loads without an R_{ISO} are allowed as the signal gain increases (increasing the unloaded phase margin). If a long trace is required, and the 6-dB signal loss intrinsic to a doubly-terminated transmission line is acceptable, implement a matched impedance transmission line using microstrip or stripline techniques (consult an ECL design handbook for microstrip and stripline layout techniques). A 50-Ω environment is normally not necessary onboard, and in fact a higher impedance environment improves distortion as shown in the distortion versus load plots. With a characteristic board trace impedance defined based on board material and trace dimensions, a matching series resistor into the trace from the output of the THS4222 is used as well as a terminating shunt resistor at the input of the destination device. Remember also that the terminating impedance is the parallel combination of the shunt resistor and the input impedance of the destination device: this total effective impedance should be set to match the trace impedance. If the 6-dB attenuation of a doubly terminated transmission line is unacceptable, a long trace can be series-terminated at the source end only. Treat the trace as a capacitive load in this case and set

the series resistor value as shown in the plot of R_{ISO} vs Capacitive Load. This setting does not preserve signal integrity or a doubly-terminated line. If the input impedance of the destination device is low, there is some signal attenuation due to the voltage divider formed by the series output into the terminating impedance.

- Socketing a high speed part like the THS4222 is not recommended.** The additional lead length and pin-to-pin capacitance introduced by the socket can create a troublesome parasitic network which can make it almost impossible to achieve a smooth, stable frequency response. Best results are obtained by soldering the THS4222 onto the board.

PowerPAD™ DESIGN CONSIDERATIONS

The THS4222 family is available in a thermally-enhanced PowerPAD family of packages. These packages are constructed using a downset leadframe upon which the die is mounted [see Figure 36(a) and Figure 36(b)]. This arrangement results in the lead frame being exposed as a thermal pad on the underside of the package [see Figure 36(c)]. Because this thermal pad has direct thermal contact with the die, excellent thermal performance can be achieved by providing a good thermal path away from the thermal pad.

The PowerPAD package allows for both assembly and thermal management in one manufacturing operation.

During the surface-mount solder operation (when the leads are being soldered), the thermal pad can also be soldered to a copper area underneath the package. Through the use of thermal paths within this copper area, heat can be conducted away from the package into either a ground plane or other heat dissipating device.

The PowerPAD package represents a breakthrough in combining the small area and ease of assembly of surface mount with the heretofore awkward mechanical methods of heatsinking.

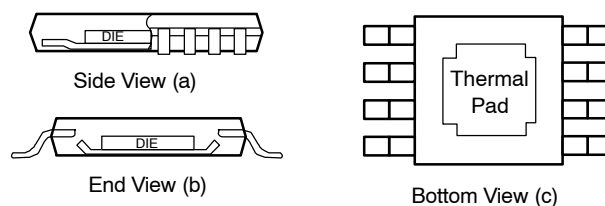

Figure 36. Views of Thermally Enhanced Package

Although there are many ways to properly heatsink the PowerPAD package, the following steps illustrate the recommended approach.

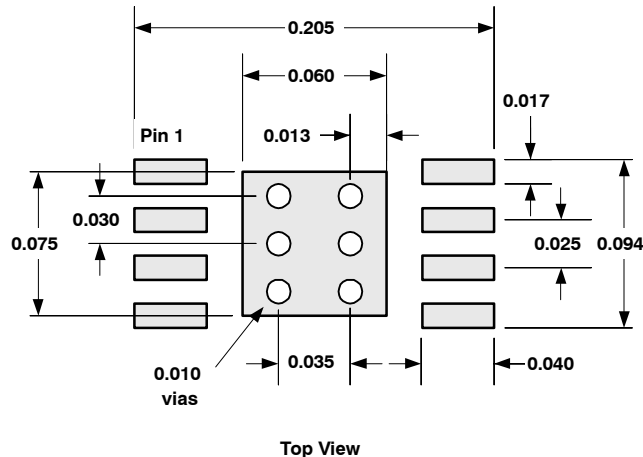

Figure 37. PowerPAD PCB Etch and Via Pattern

PowerPAD PCB LAYOUT CONSIDERATIONS

1. Prepare the PCB with a top side etch pattern as shown in Figure 37. There should be etch for the leads as well as etch for the thermal pad.
2. Place five holes in the area of the thermal pad. These holes should be 13 mils in diameter. Keep them small so that solder wicking through the holes is not a problem during reflow.
3. Additional vias may be placed anywhere along the thermal plane outside of the thermal pad area. They help dissipate the heat generated by the THS4222 family IC. These additional vias may be larger than the 13-mil diameter vias directly under the thermal pad. They can be larger because they are not in the thermal pad area to be soldered, so that wicking is not a problem.
4. Connect all holes to the internal ground plane.
5. When connecting these holes to the ground plane, **do not** use the typical web or spoke via connection methodology. Web connections have a high thermal resistance connection that is useful for slowing the heat transfer during soldering operations. This resistance makes the soldering of vias that have plane connections easier. In this application, however, low thermal resistance is desired for the most efficient heat transfer. Therefore, the holes under the THS4222 family PowerPAD package should make their connection to the internal ground plane, with a complete connection around the entire circumference of the plated-through hole.
6. The top-side solder mask should leave the terminals of the package and the thermal pad area with its five holes exposed. The bottom-side solder mask should cover the five holes of the thermal pad area. This

prevents solder from being pulled away from the thermal pad area during the reflow process.

7. Apply solder paste to the exposed thermal pad area and all of the IC terminals.
8. With these preparatory steps in place, the IC is simply placed in position and run through the solder reflow operation as any standard surface-mount component. This results in a part that is properly installed.

For a given θ_{JA} , the maximum power dissipation is shown in Figure 38 and is calculated by the equation 5:

$$P_D = \frac{T_{max} - T_A}{\theta_{JA}} \quad (3)$$

where:

P_D = Maximum power dissipation of THS4222 (watts)

T_{MAX} = Absolute maximum junction temperature (150°C)

T_A = Free-ambient temperature (°C)

$\theta_{JA} = \theta_{JC} + \theta_{CA}$

θ_{JC} = Thermal coefficient from junction to the case

θ_{CA} = Thermal coefficient from the case to ambient air (°C/W).

The next consideration is the package constraints. The two sources of heat within an amplifier are quiescent power and output power. The designer should never forget about the quiescent heat generated within the device, especially multi-amplifier devices. Because these devices have linear output stages (Class AB), most of the heat dissipation is at low output voltages with high output currents.

The other key factor when dealing with power dissipation is how the devices are mounted on the PCB. The PowerPAD devices are extremely useful for heat dissipation. But, the device should always be soldered to a copper plane to fully use the heat dissipation properties of the PowerPAD. The SOIC package, on the other hand, is highly dependent on how it is mounted on the PCB. As more trace and copper area is placed around the device, θ_{JA} decreases and the heat dissipation capability increases. For a single package, the sum of the RMS output currents and voltages should be used to choose the proper package.

THERMAL ANALYSIS

The THS4222 family of devices does not incorporate automatic thermal shutoff protection, so the designer must take care to ensure that the design does not violate the absolute maximum junction temperature of the device. Failure may result if the absolute maximum junction temperature of 150° C is exceeded.

The thermal characteristics of the device are dictated by the package and the PC board. Maximum power dissipation for a given package can be calculated using the following formula.

$$P_{Dmax} = \frac{T_{max} - T_A}{\theta_{JA}}$$

where:

P_{Dmax} is the maximum power dissipation in the amplifier (W).

T_{max} is the absolute maximum junction temperature (°C).

T_A is the ambient temperature (°C).

$\theta_{JA} = \theta_{JC} + \theta_{CA}$

θ_{JC} is the thermal coefficient from the silicon junctions to the case (°C/W).

θ_{CA} is the thermal coefficient from the case to ambient air (°C/W).

For systems where heat dissipation is more critical, the THS4222 family is offered in MSOP with PowerPAD. The thermal coefficient for the MSOP PowerPAD package is substantially improved over the traditional SOIC. Maximum power dissipation levels are depicted in the graph for the two packages. The data for the DGN package assumes a board layout that follows the PowerPAD layout guidelines referenced above and detailed in the PowerPAD application notes in the *Additional Reference Material* section at the end of the data sheet.

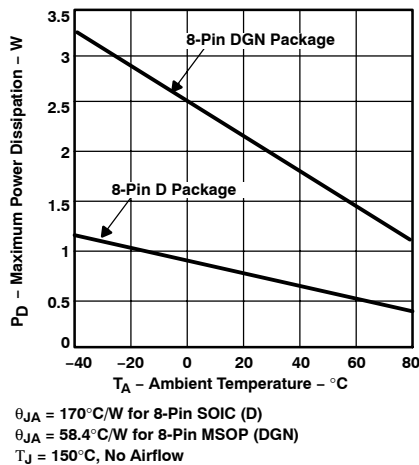

Figure 38. Maximum Power Dissipation vs Ambient Temperature

When determining whether or not the device satisfies the maximum power dissipation requirement, it is important to consider not only quiescent power dissipation, but also dynamic power dissipation. Often maximum power dissipation is difficult to quantify because the signal pattern is inconsistent, but an estimate of the RMS power dissipation can provide visibility into a possible problem.

DESIGN TOOLS

Evaluation Fixtures, Spice Models, and Applications Support

Texas Instruments is committed to providing its customers with the highest quality of applications support. To support this goal, evaluation boards have been developed for the THS4222 family of operational amplifiers. The boards are easy to use, allowing for straight-forward evaluation of the device. These evaluation boards can be ordered through the Texas Instruments web site, www.ti.com, or through your local Texas Instruments sales representative. Schematics for the two evaluation boards are shown below with their default component values. Unpopulated footprints are shown to provide insight into design flexibility.

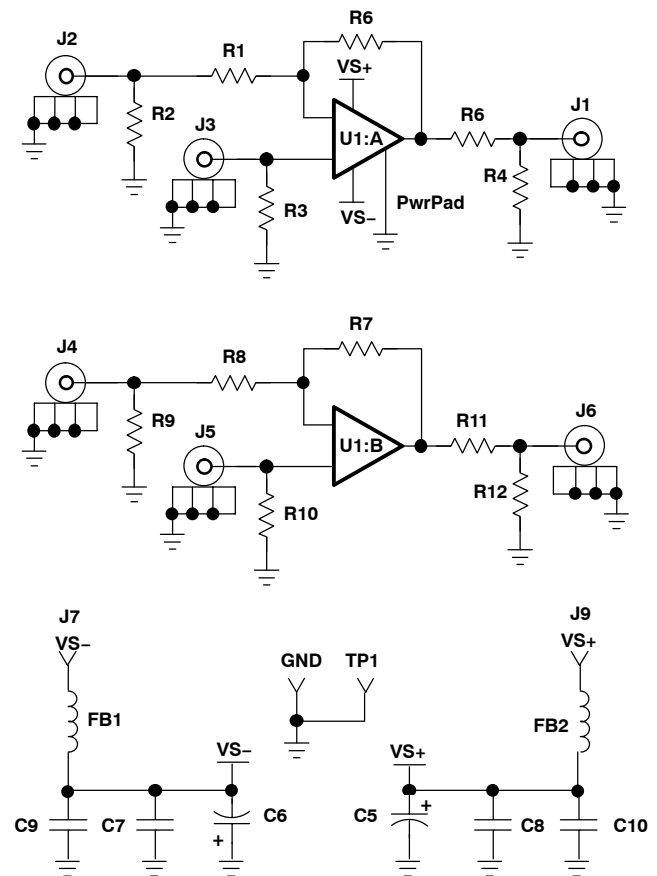

Figure 39. THS4222 EVM Circuit Configuration

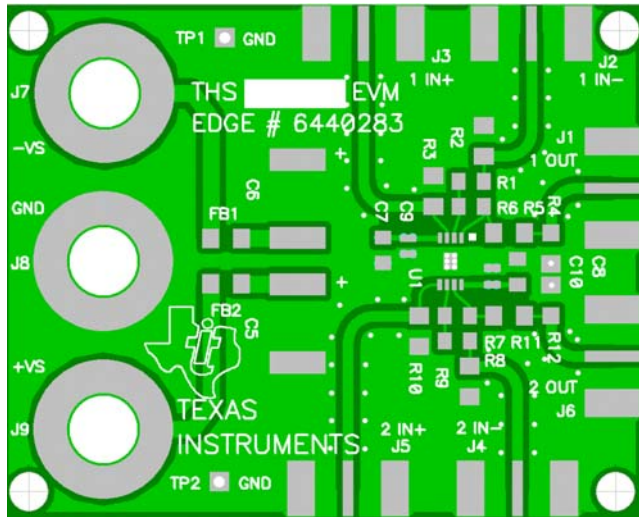

Figure 40. THS4222 EVM Board Layout (Top Layer)

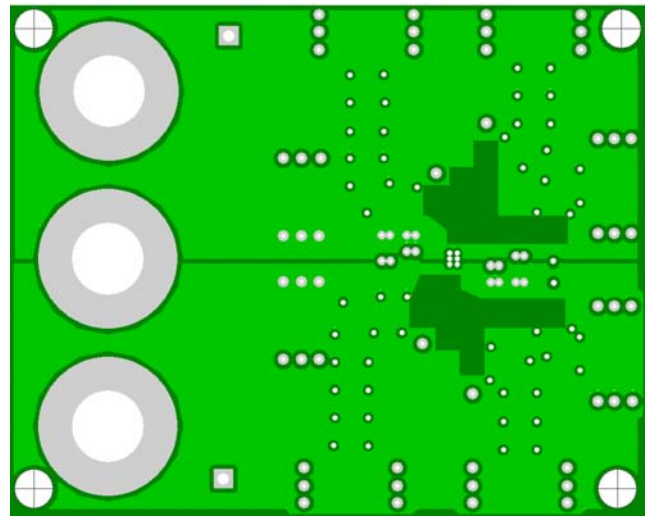

Figure 42. THS4222 EVM Board Layout (3rd Layer, Power)

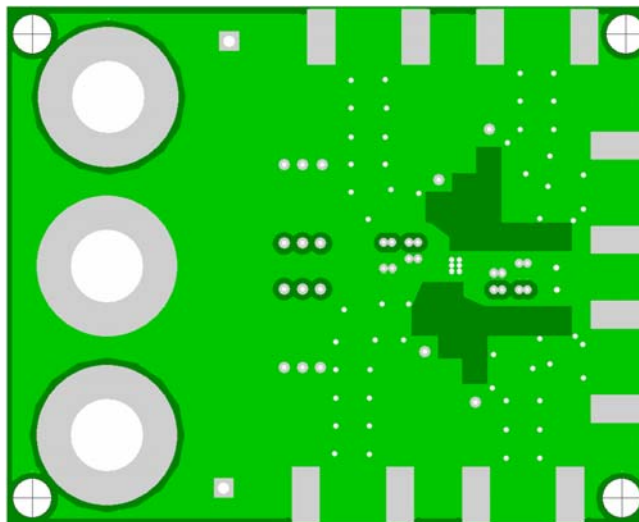

Figure 41. THS4222 EVM Board Layout (2nd Layer, Ground)

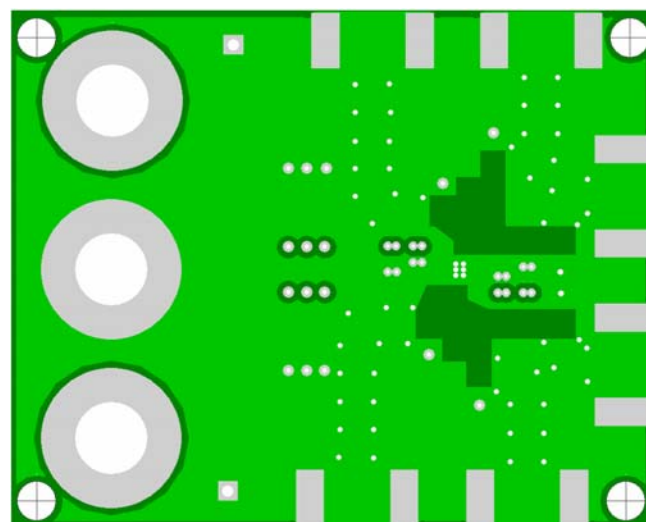

Figure 43. THS4222 EVM Board Layout (Bottom Layer)

Computer simulation of circuit performance using SPICE is often useful when analyzing the performance of analog circuits and systems. This is particularly true for video and RF amplifier circuits where parasitic capacitance and inductance can have a major effect on circuit performance. A SPICE model for the THS4222 family is available through the Texas Instruments web site (www.ti.com). The PIC is also available for design assistance and detailed product information. These models do a good job of predicting small-signal ac and transient performance under a wide variety of operating conditions. They are not intended to model the distortion characteristics of the

amplifier, nor do they attempt to distinguish between the package types in their small-signal ac performance. Detailed information about what is and is not modeled is contained in the model file itself.

ADDITIONAL REFERENCE MATERIAL

- *PowerPAD Made Easy*, application brief (SLMA004)
- *PowerPAD Thermally Enhanced Package*, technical brief (SLMA002)

PACKAGING INFORMATION

Orderable Device	Status (1)	Package Type	Package Drawing	Pins	Package Qty	Eco Plan (2)	Lead/Ball Finish (6)	MSL Peak Temp (3)	Op Temp (°C)	Device Marking (4/5)	Samples
THS4221D	ACTIVE	SOIC	D	8	75	Green (RoHS & no Sb/Br)	CU NIPDAU	Level-1-260C-UNLIM	-40 to 85	4221	Samples
THS4221DBVR	ACTIVE	SOT-23	DBV	5	3000	Green (RoHS & no Sb/Br)	CU NIPDAU	Level-1-260C-UNLIM	-40 to 85	BFS	Samples
THS4221DBVT	ACTIVE	SOT-23	DBV	5	250	Green (RoHS & no Sb/Br)	CU NIPDAU	Level-1-260C-UNLIM	-40 to 85	BFS	Samples
THS4221DBVTG4	ACTIVE	SOT-23	DBV	5	250	Green (RoHS & no Sb/Br)	CU NIPDAU	Level-1-260C-UNLIM	-40 to 85	BFS	Samples
THS4221DGK	ACTIVE	VSSOP	DGK	8	80	Green (RoHS & no Sb/Br)	CU NIPDAU	Level-1-260C-UNLIM	-40 to 85	BHX	Samples
THS4221DGKR	ACTIVE	VSSOP	DGK	8	2500	Green (RoHS & no Sb/Br)	CU NIPDAU	Level-1-260C-UNLIM	-40 to 85	BHX	Samples
THS4221DGN	ACTIVE	MSOP-PowerPAD	DGN	8	80	Green (RoHS & no Sb/Br)	CU NIPDAU	Level-1-260C-UNLIM	-40 to 85	BFT	Samples
THS4222D	ACTIVE	SOIC	D	8	75	Green (RoHS & no Sb/Br)	CU NIPDAU	Level-1-260C-UNLIM	-40 to 85	4222	Samples
THS4222DGK	ACTIVE	VSSOP	DGK	8	80	Green (RoHS & no Sb/Br)	CU NIPDAU CU NIPDAUAG	Level-1-260C-UNLIM	-40 to 85	BHW	Samples
THS4222DGN	ACTIVE	MSOP-PowerPAD	DGN	8	80	Green (RoHS & no Sb/Br)	CU NIPDAU CU NIPDAUAG	Level-1-260C-UNLIM	-40 to 85	BFO	Samples
THS4222DGNR	ACTIVE	MSOP-PowerPAD	DGN	8	2500	Green (RoHS & no Sb/Br)	CU NIPDAU CU NIPDAUAG	Level-1-260C-UNLIM	-40 to 85	BFO	Samples
THS4222DR	ACTIVE	SOIC	D	8	2500	Green (RoHS & no Sb/Br)	CU NIPDAU	Level-1-260C-UNLIM	-40 to 85	4222	Samples
THS4225D	ACTIVE	SOIC	D	8	75	Green (RoHS & no Sb/Br)	CU NIPDAU	Level-1-260C-UNLIM	-40 to 85	4225	Samples
THS4225DGK	ACTIVE	VSSOP	DGK	8	80	Green (RoHS & no Sb/Br)	CU NIPDAU	Level-1-260C-UNLIM	-40 to 85	BFY	Samples
THS4225DGN	ACTIVE	MSOP-PowerPAD	DGN	8	80	Green (RoHS & no Sb/Br)	CU NIPDAU	Level-1-260C-UNLIM	-40 to 85	BFU	Samples
THS4226DGQ	ACTIVE	MSOP-PowerPAD	DGQ	10	80	Green (RoHS & no Sb/Br)	CU NIPDAU	Level-1-260C-UNLIM	-40 to 85	BFP	Samples

(1) The marketing status values are defined as follows:
ACTIVE: Product device recommended for new designs.

LIFEBUY: TI has announced that the device will be discontinued, and a lifetime-buy period is in effect.

NRND: Not recommended for new designs. Device is in production to support existing customers, but TI does not recommend using this part in a new design.

PREVIEW: Device has been announced but is not in production. Samples may or may not be available.

OBSOLETE: TI has discontinued the production of the device.

⁽²⁾ **RoHS:** TI defines "RoHS" to mean semiconductor products that are compliant with the current EU RoHS requirements for all 10 RoHS substances, including the requirement that RoHS substance do not exceed 0.1% by weight in homogeneous materials. Where designed to be soldered at high temperatures, "RoHS" products are suitable for use in specified lead-free processes. TI may reference these types of products as "Pb-Free".

RoHS Exempt: TI defines "RoHS Exempt" to mean products that contain lead but are compliant with EU RoHS pursuant to a specific EU RoHS exemption.

Green: TI defines "Green" to mean the content of Chlorine (Cl) and Bromine (Br) based flame retardants meet JS709B low halogen requirements of ≤ 1000 ppm threshold. Antimony trioxide based flame retardants must also meet the ≤ 1000 ppm threshold requirement.

⁽³⁾ MSL, Peak Temp. - The Moisture Sensitivity Level rating according to the JEDEC industry standard classifications, and peak solder temperature.

⁽⁴⁾ There may be additional marking, which relates to the logo, the lot trace code information, or the environmental category on the device.

⁽⁵⁾ Multiple Device Markings will be inside parentheses. Only one Device Marking contained in parentheses and separated by a "~" will appear on a device. If a line is indented then it is a continuation of the previous line and the two combined represent the entire Device Marking for that device.

⁽⁶⁾ Lead/Ball Finish - Orderable Devices may have multiple material finish options. Finish options are separated by a vertical ruled line. Lead/Ball Finish values may wrap to two lines if the finish value exceeds the maximum column width.

Important Information and Disclaimer: The information provided on this page represents TI's knowledge and belief as of the date that it is provided. TI bases its knowledge and belief on information provided by third parties, and makes no representation or warranty as to the accuracy of such information. Efforts are underway to better integrate information from third parties. TI has taken and continues to take reasonable steps to provide representative and accurate information but may not have conducted destructive testing or chemical analysis on incoming materials and chemicals. TI and TI suppliers consider certain information to be proprietary, and thus CAS numbers and other limited information may not be available for release.

In no event shall TI's liability arising out of such information exceed the total purchase price of the TI part(s) at issue in this document sold by TI to Customer on an annual basis.

TAPE AND REEL INFORMATION

QUADRANT ASSIGNMENTS FOR PIN 1 ORIENTATION IN TAPE

*All dimensions are nominal

Device	Package Type	Package Drawing	Pins	SPQ	Reel Diameter (mm)	Reel Width W1 (mm)	A0 (mm)	B0 (mm)	K0 (mm)	P1 (mm)	W (mm)	Pin1 Quadrant
THS4221DBVR	SOT-23	DBV	5	3000	180.0	9.0	3.15	3.2	1.4	4.0	8.0	Q3
THS4221DBVT	SOT-23	DBV	5	250	180.0	9.0	3.15	3.2	1.4	4.0	8.0	Q3
THS4221DGKR	VSSOP	DGK	8	2500	330.0	12.4	5.3	3.4	1.4	8.0	12.0	Q1
THS4222DGNR	MSOP-Power PAD	DGN	8	2500	330.0	12.4	5.3	3.4	1.4	8.0	12.0	Q1
THS4222DR	SOIC	D	8	2500	330.0	12.4	6.4	5.2	2.1	8.0	12.0	Q1

TAPE AND REEL BOX DIMENSIONS

*All dimensions are nominal

Device	Package Type	Package Drawing	Pins	SPQ	Length (mm)	Width (mm)	Height (mm)
THS4221DBVR	SOT-23	DBV	5	3000	182.0	182.0	20.0
THS4221DBVT	SOT-23	DBV	5	250	182.0	182.0	20.0
THS4221DGKR	VSSOP	DGK	8	2500	358.0	335.0	35.0
THS4222DGNR	MSOP-PowerPAD	DGN	8	2500	364.0	364.0	27.0
THS4222DR	SOIC	D	8	2500	350.0	350.0	43.0



D0008A

PACKAGE OUTLINE

SOIC - 1.75 mm max height

SMALL OUTLINE INTEGRATED CIRCUIT



4214825/C 02/2019

NOTES:

1. Linear dimensions are in inches [millimeters]. Dimensions in parenthesis are for reference only. Controlling dimensions are in inches. Dimensioning and tolerancing per ASME Y14.5M.
2. This drawing is subject to change without notice.
3. This dimension does not include mold flash, protrusions, or gate burrs. Mold flash, protrusions, or gate burrs shall not exceed $.006$ [0.15] per side.
4. This dimension does not include interlead flash.
5. Reference JEDEC registration MS-012, variation AA.

EXAMPLE BOARD LAYOUT

D0008A

SOIC - 1.75 mm max height

SMALL OUTLINE INTEGRATED CIRCUIT



LAND PATTERN EXAMPLE
 EXPOSED METAL SHOWN
 SCALE:8X



SOLDER MASK DETAILS

4214825/C 02/2019

NOTES: (continued)

- 6. Publication IPC-7351 may have alternate designs.
- 7. Solder mask tolerances between and around signal pads can vary based on board fabrication site.

EXAMPLE STENCIL DESIGN

D0008A

SOIC - 1.75 mm max height

SMALL OUTLINE INTEGRATED CIRCUIT



SOLDER PASTE EXAMPLE
BASED ON .005 INCH [0.125 MM] THICK STENCIL
SCALE:8X

4214825/C 02/2019

NOTES: (continued)

8. Laser cutting apertures with trapezoidal walls and rounded corners may offer better paste release. IPC-7525 may have alternate design recommendations.
9. Board assembly site may have different recommendations for stencil design.

EXAMPLE BOARD LAYOUT

DBV0005A

SOT-23 - 1.45 mm max height

SMALL OUTLINE TRANSISTOR



LAND PATTERN EXAMPLE
EXPOSED METAL SHOWN
SCALE:15X



SOLDER MASK DETAILS

4214839/D 11/2018

NOTES: (continued)

- 5. Publication IPC-7351 may have alternate designs.
- 6. Solder mask tolerances between and around signal pads can vary based on board fabrication site.

EXAMPLE STENCIL DESIGN

DBV0005A

SOT-23 - 1.45 mm max height

SMALL OUTLINE TRANSISTOR



SOLDER PASTE EXAMPLE
BASED ON 0.125 mm THICK STENCIL
SCALE:15X

4214839/D 11/2018

NOTES: (continued)

7. Laser cutting apertures with trapezoidal walls and rounded corners may offer better paste release. IPC-7525 may have alternate design recommendations.
8. Board assembly site may have different recommendations for stencil design.

DGK (S-PDSO-G8)

PLASTIC SMALL-OUTLINE PACKAGE

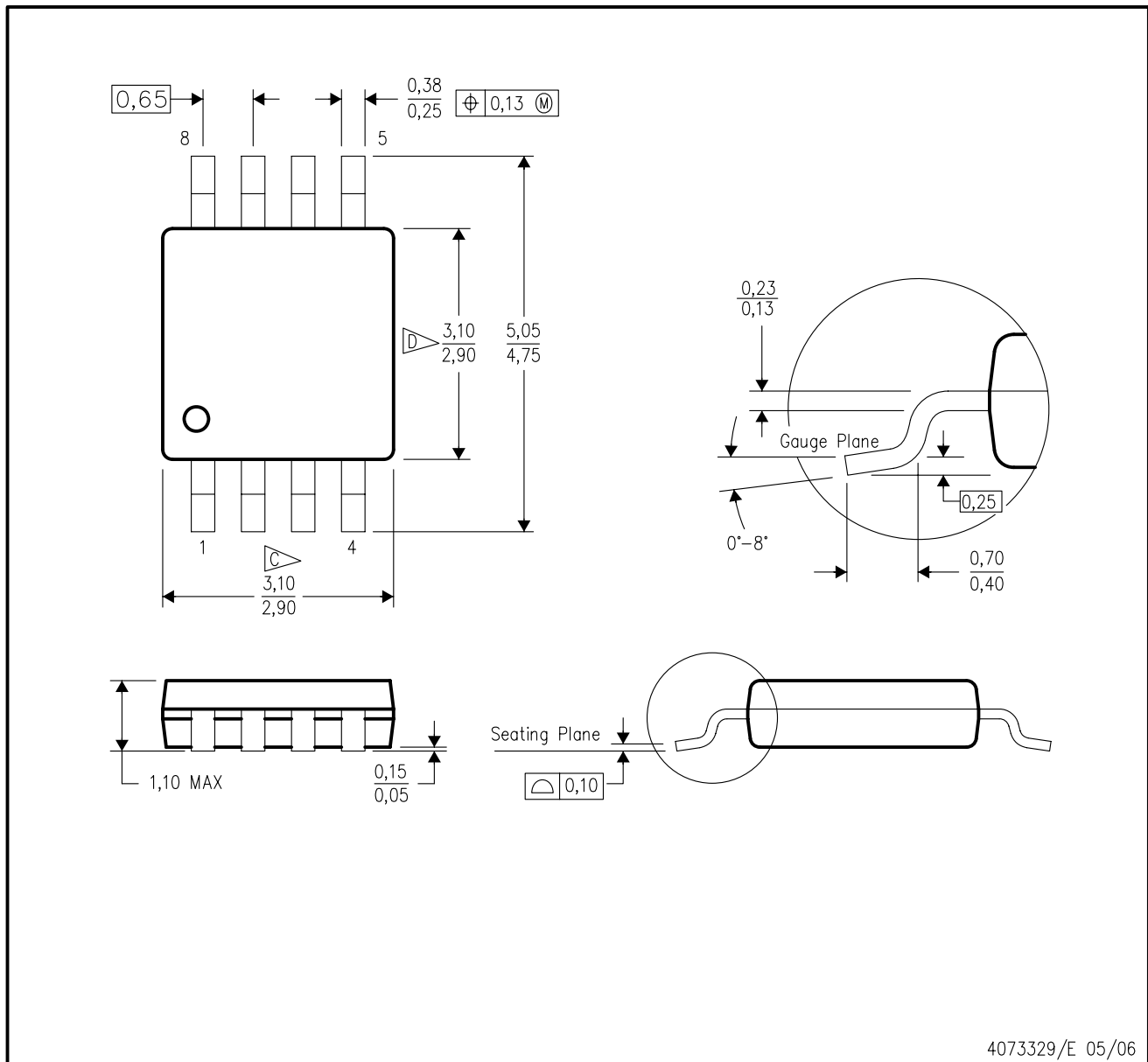

- NOTES:
- A. All linear dimensions are in millimeters.
 - B. This drawing is subject to change without notice.
 - C. Body length does not include mold flash, protrusions, or gate burrs. Mold flash, protrusions, or gate burrs shall not exceed 0.15 per end.
 - D. Body width does not include interlead flash. Interlead flash shall not exceed 0.50 per side.
 - E. Falls within JEDEC MO-187 variation AA, except interlead flash.



- NOTES:
- A. All linear dimensions are in millimeters.
 - B. This drawing is subject to change without notice.
 - C. Publication IPC-7351 is recommended for alternate designs.
 - D. Laser cutting apertures with trapezoidal walls and also rounding corners will offer better paste release. Customers should contact their board assembly site for stencil design recommendations. Refer to IPC-7525 for other stencil recommendations.
 - E. Customers should contact their board fabrication site for solder mask tolerances between and around signal pads.

DGQ (S-PDSO-G10)

PowerPAD™ PLASTIC SMALL OUTLINE

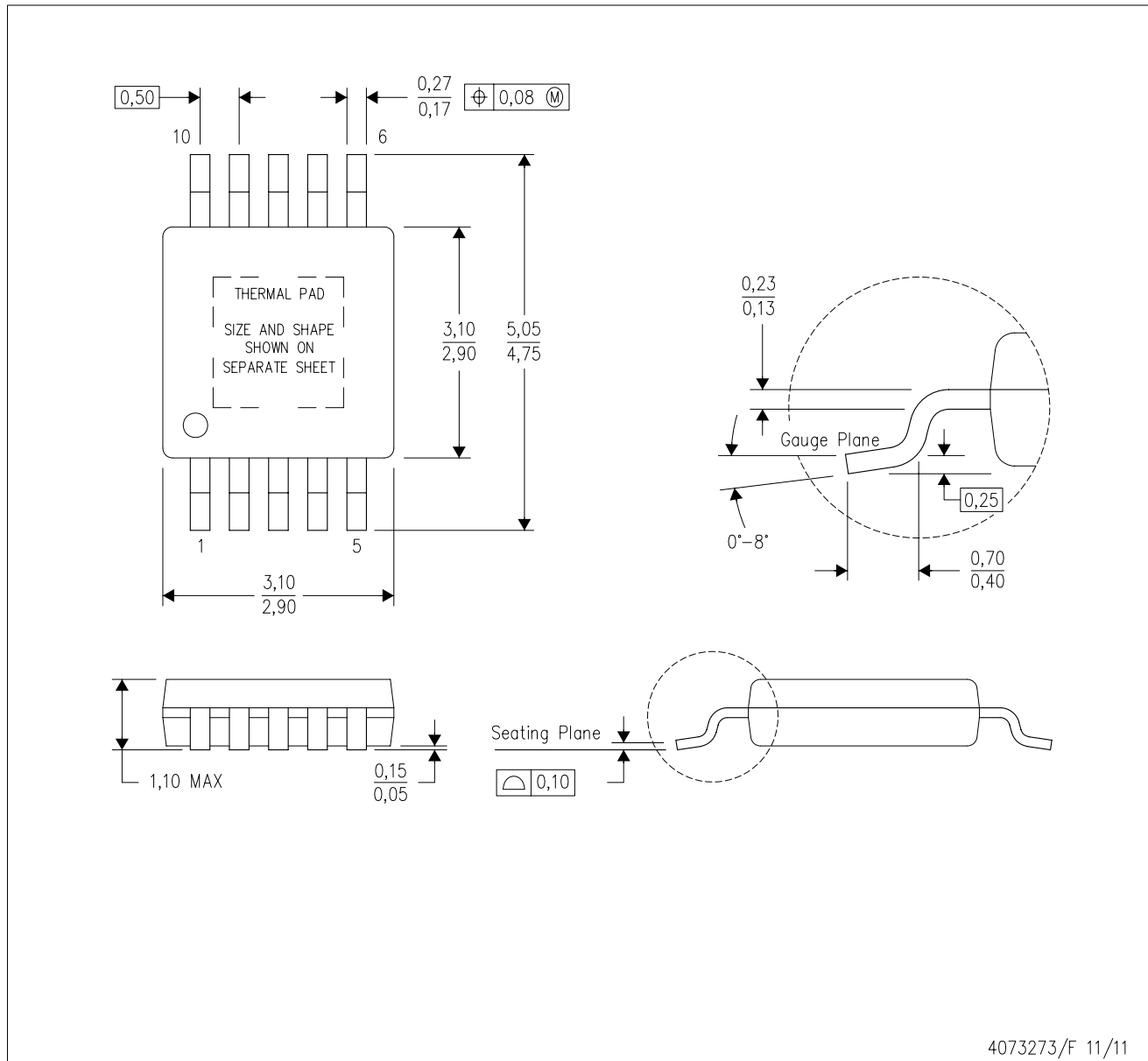

- NOTES:
- A. All linear dimensions are in millimeters.
 - B. This drawing is subject to change without notice.
 - C. Body dimensions do not include mold flash or protrusion not to exceed 0,15.
 - D. This package is designed to be soldered to a thermal pad on the board. Refer to Technical Brief, PowerPad Thermally Enhanced Package, Texas Instruments Literature No. SLMA002 for information regarding recommended board layout. This document is available at www.ti.com <<http://www.ti.com>>.
 - E. See the additional figure in the Product Data Sheet for details regarding the exposed thermal pad features and dimensions.
 - F. Falls within JEDEC MO-187 variation BA-T.

PowerPAD is a trademark of Texas Instruments.

DGQ (S-PDSO-G10)

PowerPAD™ PLASTIC SMALL OUTLINE

THERMAL INFORMATION

This PowerPAD™ package incorporates an exposed thermal pad that is designed to be attached to a printed circuit board (PCB). The thermal pad must be soldered directly to the PCB. After soldering, the PCB can be used as a heatsink. In addition, through the use of thermal vias, the thermal pad can be attached directly to the appropriate copper plane shown in the electrical schematic for the device, or alternatively, can be attached to a special heatsink structure designed into the PCB. This design optimizes the heat transfer from the integrated circuit (IC).

For additional information on the PowerPAD package and how to take advantage of its heat dissipating abilities, refer to Technical Brief, PowerPAD Thermally Enhanced Package, Texas Instruments Literature No. SLMA002 and Application Brief, PowerPAD Made Easy, Texas Instruments Literature No. SLMA004. Both documents are available at www.ti.com.

The exposed thermal pad dimensions for this package are shown in the following illustration.

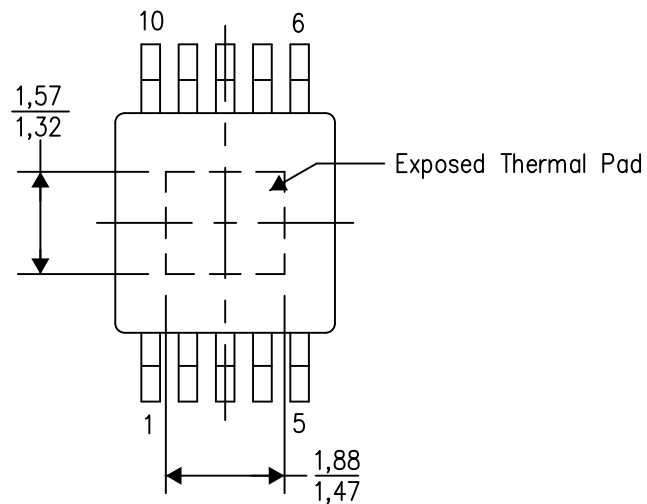

Top View

Exposed Thermal Pad Dimensions

4206324-2/H 12/14

NOTE: A. All linear dimensions are in millimeters

PowerPAD is a trademark of Texas Instruments

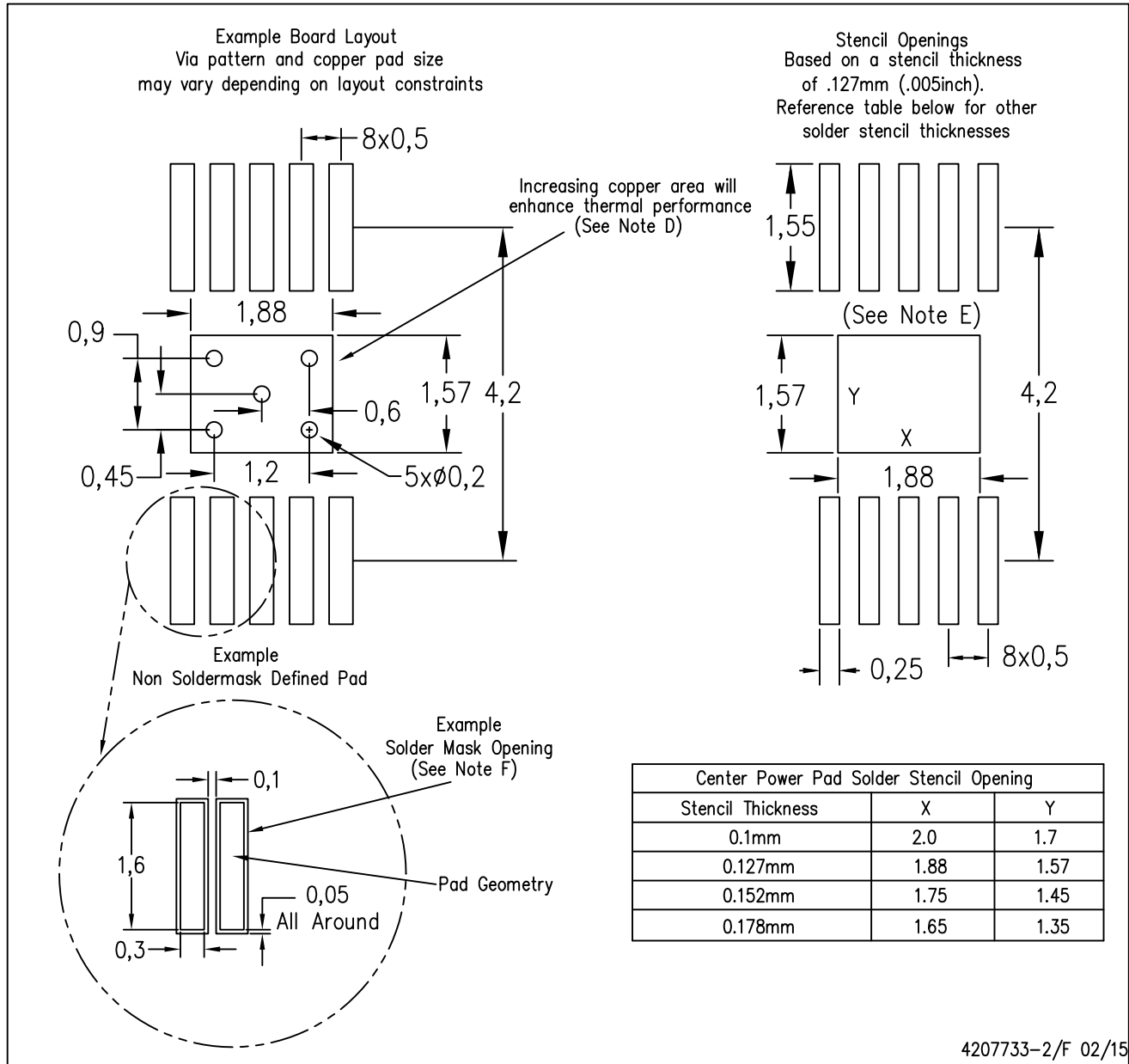

- NOTES:
- All linear dimensions are in millimeters.
 - This drawing is subject to change without notice.
 - Customers should place a note on the circuit board fabrication drawing not to alter the center solder mask defined pad.
 - This package is designed to be soldered to a thermal pad on the board. Refer to Technical Brief, PowerPad Thermally Enhanced Package, Texas Instruments Literature No. SLMA002, SLMA004, and also the Product Data Sheets for specific thermal information, via requirements, and recommended board layout. These documents are available at www.ti.com <<http://www.ti.com>>. Publication IPC-7351 is recommended for alternate designs.
 - Laser cutting apertures with trapezoidal walls and also rounding corners will offer better paste release. Customers should contact their board assembly site for stencil design recommendations. Example stencil design based on a 50% volumetric metal load solder paste. Refer to IPC-7525 for other stencil recommendations.
 - Customers should contact their board fabrication site for solder mask tolerances between and around signal pads.

PowerPAD is a trademark of Texas Instruments

DGN (S-PDSO-G8)

PowerPAD™ PLASTIC SMALL OUTLINE

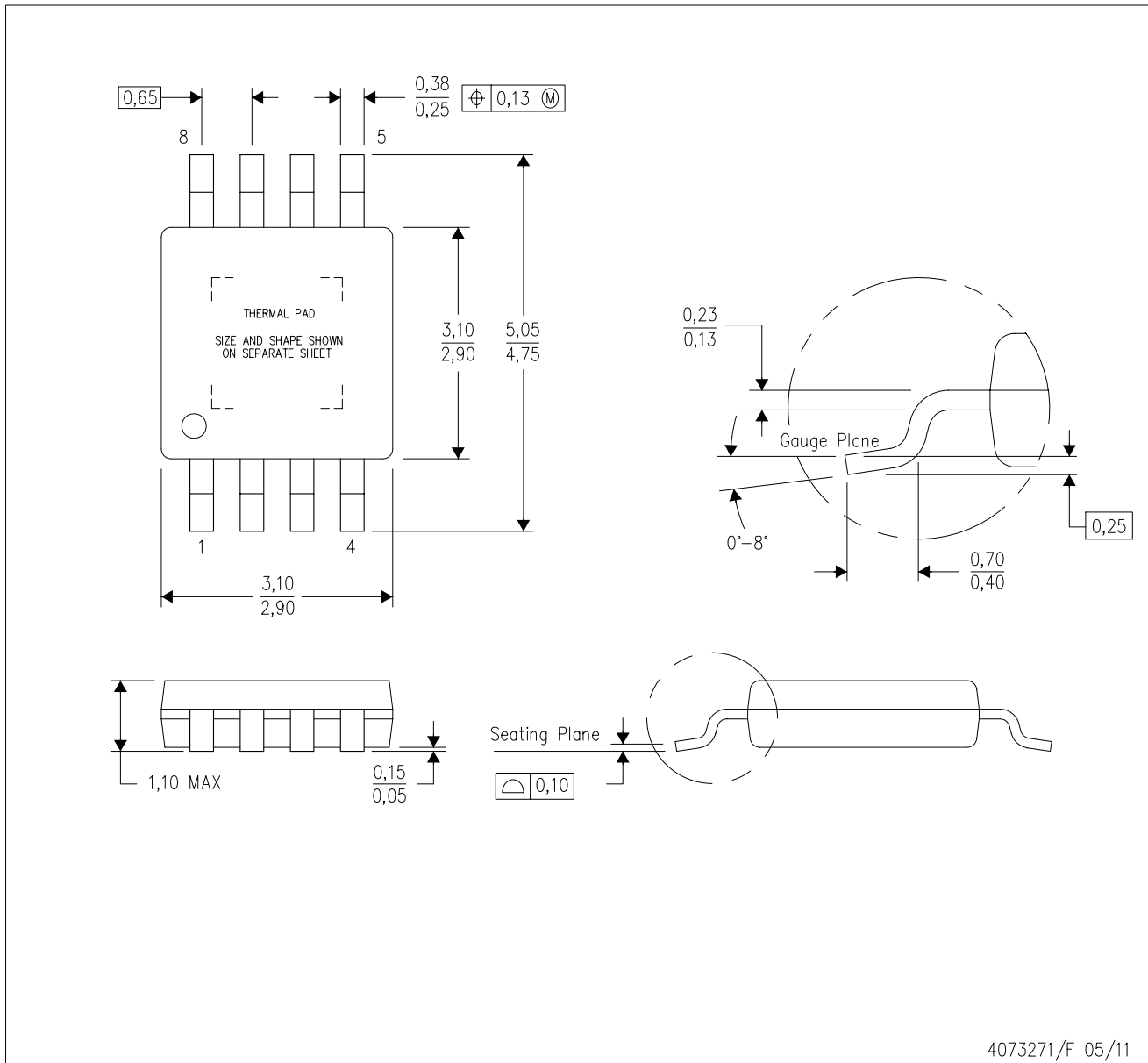

- NOTES:
- All linear dimensions are in millimeters.
 - This drawing is subject to change without notice.
 - Body dimensions do not include mold flash or protrusion.
 - This package is designed to be soldered to a thermal pad on the board. Refer to Technical Brief, PowerPad Thermally Enhanced Package, Texas Instruments Literature No. SLMA002 for information regarding recommended board layout. This document is available at www.ti.com <<http://www.ti.com>>.
 - See the additional figure in the Product Data Sheet for details regarding the exposed thermal pad features and dimensions.
 - Falls within JEDEC MO-187 variation AA-T

PowerPAD is a trademark of Texas Instruments.

DGN (S-PDSO-G8)

PowerPAD™ PLASTIC SMALL OUTLINE

THERMAL INFORMATION

This PowerPAD™ package incorporates an exposed thermal pad that is designed to be attached to a printed circuit board (PCB). The thermal pad must be soldered directly to the PCB. After soldering, the PCB can be used as a heatsink. In addition, through the use of thermal vias, the thermal pad can be attached directly to the appropriate copper plane shown in the electrical schematic for the device, or alternatively, can be attached to a special heatsink structure designed into the PCB. This design optimizes the heat transfer from the integrated circuit (IC).

For additional information on the PowerPAD package and how to take advantage of its heat dissipating abilities, refer to Technical Brief, PowerPAD Thermally Enhanced Package, Texas Instruments Literature No. SLMA002 and Application Brief, PowerPAD Made Easy, Texas Instruments Literature No. SLMA004. Both documents are available at www.ti.com.

The exposed thermal pad dimensions for this package are shown in the following illustration.

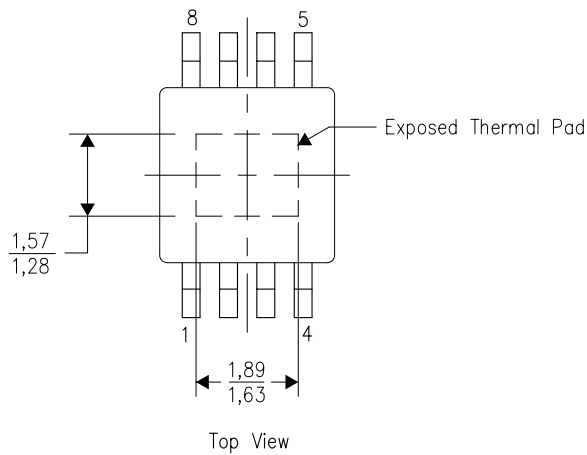

Exposed Thermal Pad Dimensions

4206323-2/1 12/11

NOTE: All linear dimensions are in millimeters

PowerPAD is a trademark of Texas Instruments

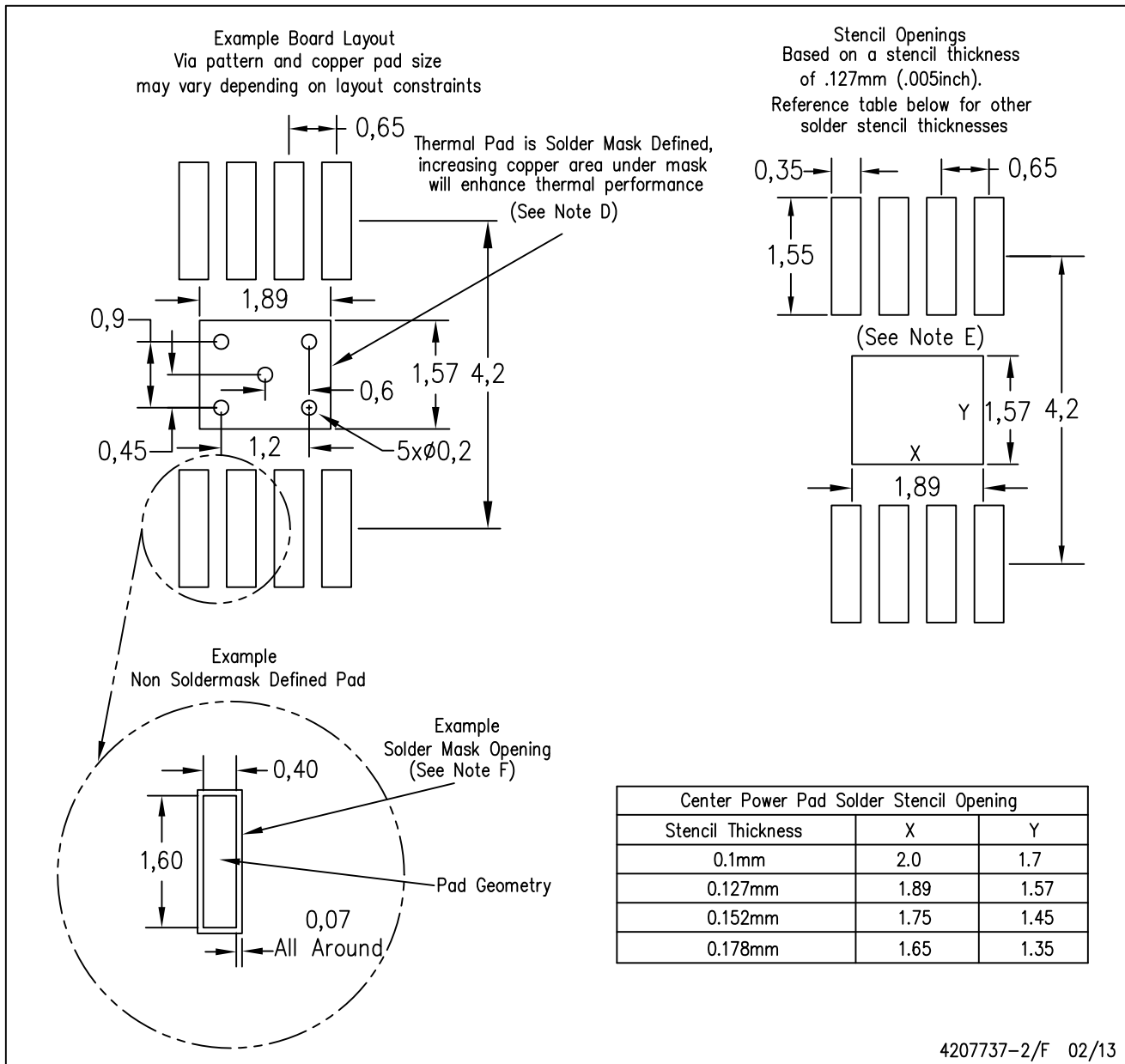

- NOTES:
- A. All linear dimensions are in millimeters.
 - B. This drawing is subject to change without notice.
 - C. Customers should place a note on the circuit board fabrication drawing not to alter the center solder mask defined pad.
 - D. This package is designed to be soldered to a thermal pad on the board. Refer to Technical Brief, PowerPad Thermally Enhanced Package, Texas Instruments Literature No. SLMA002, SLMA004, and also the Product Data Sheets for specific thermal information, via requirements, and recommended board layout. These documents are available at www.ti.com <<http://www.ti.com>>.
 - E. Laser cutting apertures with trapezoidal walls and also rounding corners will offer better paste release. Customers should contact their board assembly site for stencil design recommendations. Example stencil design based on a 50% volumetric metal load solder paste. Refer to IPC-7525 for other stencil recommendations.
 - F. Customers should contact their board fabrication site for solder mask tolerances between and around signal pads.

PowerPAD is a trademark of Texas Instruments

IMPORTANT NOTICE AND DISCLAIMER

TI PROVIDES TECHNICAL AND RELIABILITY DATA (INCLUDING DATASHEETS), DESIGN RESOURCES (INCLUDING REFERENCE DESIGNS), APPLICATION OR OTHER DESIGN ADVICE, WEB TOOLS, SAFETY INFORMATION, AND OTHER RESOURCES "AS IS" AND WITH ALL FAULTS, AND DISCLAIMS ALL WARRANTIES, EXPRESS AND IMPLIED, INCLUDING WITHOUT LIMITATION ANY IMPLIED WARRANTIES OF MERCHANTABILITY, FITNESS FOR A PARTICULAR PURPOSE OR NON-INFRINGEMENT OF THIRD PARTY INTELLECTUAL PROPERTY RIGHTS.

These resources are intended for skilled developers designing with TI products. You are solely responsible for (1) selecting the appropriate TI products for your application, (2) designing, validating and testing your application, and (3) ensuring your application meets applicable standards, and any other safety, security, or other requirements. These resources are subject to change without notice. TI grants you permission to use these resources only for development of an application that uses the TI products described in the resource. Other reproduction and display of these resources is prohibited. No license is granted to any other TI intellectual property right or to any third party intellectual property right. TI disclaims responsibility for, and you will fully indemnify TI and its representatives against, any claims, damages, costs, losses, and liabilities arising out of your use of these resources.

TI's products are provided subject to TI's Terms of Sale (www.ti.com/legal/termsofsale.html) or other applicable terms available either on ti.com or provided in conjunction with such TI products. TI's provision of these resources does not expand or otherwise alter TI's applicable warranties or warranty disclaimers for TI products.

Mailing Address: Texas Instruments, Post Office Box 655303, Dallas, Texas 75265
Copyright © 2019, Texas Instruments Incorporated

Looking for pricing, stock, or lifecycle information?

Click below to explore more details on WIN SOURCE:

 [View THS4221DBVR on WIN SOURCE](#)

 [Texas Instruments](#) Information

Optimize Your Supply Chain with WIN SOURCE Solutions

-  Global Sourcing Solution
-  Obsolete Management
-  Cost Control Management
-  Shortage Management
-  Alternative Solution
-  Excess Inventory Management