



**THE DATASHEET OF
AS1302-BWLT**





austriamicrosystems AG

is now

ams AG

The technical content of this austriamicrosystems datasheet is still valid.

Contact information:

Headquarters:

ams AG
Tobelbaderstrasse 30
8141 Unterpremstaetten, Austria
Tel: +43 (0) 3136 500 0
e-Mail: ams_sales@ams.com

Please visit our website at www.ams.com

AS1302

5V/30mA Adaptive Inductorless Boost Converter

1 General Description

The AS1302 is a 30mA inductorless boost converter using a double H-bridge charge-pump topology with two external flying capacitors. The AS1302 charge pump features 1:2 and 2:3 operation modes as well as a 1:1 operation mode where the input is directly connected to the output.

The AS1302 runs on a 1.2MHz fixed frequency and is utilized with a low noise regulation scheme to allow usage together with sensitive RF circuitry from the same battery supply. Additionally to increase efficiency the AS1302 switches to 49kHz at light loads.

Designed to reside in portable and space limited equipment the 1.2MHz charge pump converts a 2.9V to 5.15V input to regulated 5V output with 3% accuracy.

The shutdown function reduces the supply current to <math><1\mu\text{A}</math> and disconnects the load from the output. The integrated soft-start circuitry prevents high inrush currents being drawn from the battery during start-up.

The AS1302 includes built-in under-voltage lockout, short circuit-, and thermal protection circuitry.

The AS1302 is available in TDFN (3x3x0.8mm) 10-pin and an extremely small 1.2x1.2mm WL-CSP 8-bumps package with 0.4mm pitch.

2 Key Features

- Up to 90% Efficiency
- 2.9V to 5.15V Input Voltage
- Regulated 5V Output
- Automatic Mode Switching
- <math><1\mu\text{A}</math> Shutdown Current
- Startup with Full Load (within 1ms)
- Up to 30mA Load Current
- Short Circuit Protection
- Output Disconnected During Shutdown
- Soft-Start
- No Inductor Required
- Small External Components Required ($C_{OUT} = 2.2\mu\text{F}$, $C_{FLY} = 220\text{nF}$)
- Low Noise Fixed Frequency (1.2MHz, 49kHz) Charge Pump:
 - 1:1 Battery Feed Through Mode
 - 2:3 Single Phase Mode
 - 1:2 Single Phase Mode
- Package Options:
 - TDFN (3x3x0.8mm) 10-pin
 - WL-CSP 8-bumps with 0.4mm Pitch

3 Applications

The device is ideal for two or three AA cells or a single Li-Ion battery cell to 5V conversion, mobile phones, portable instruments, microprocessor based systems and remote data-acquisition systems.

Figure 1. AS1302 - Typical Application Diagram

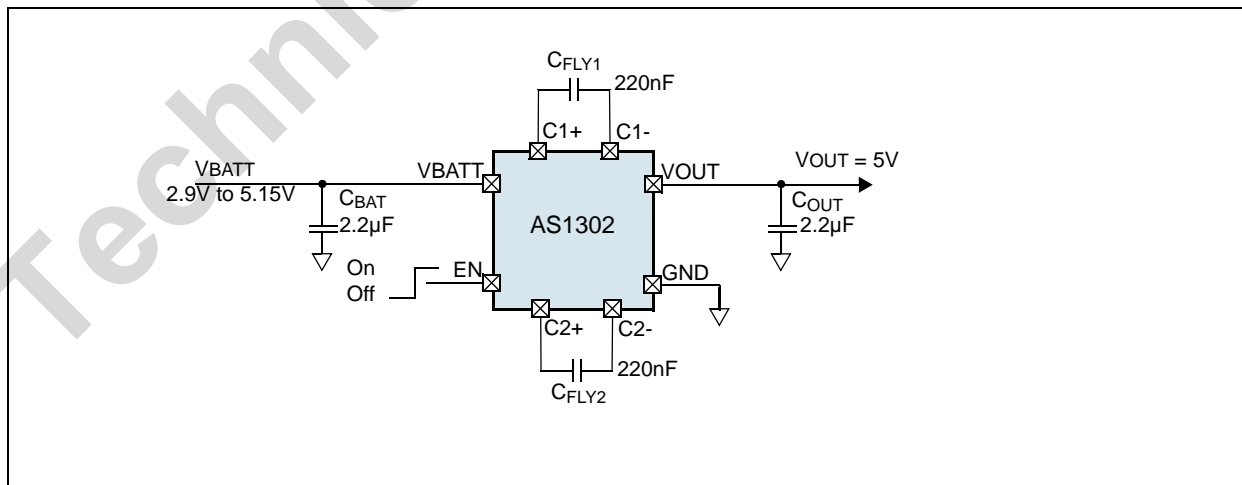

4 Pin Assignments

Figure 2. Pin Assignments (Through View)

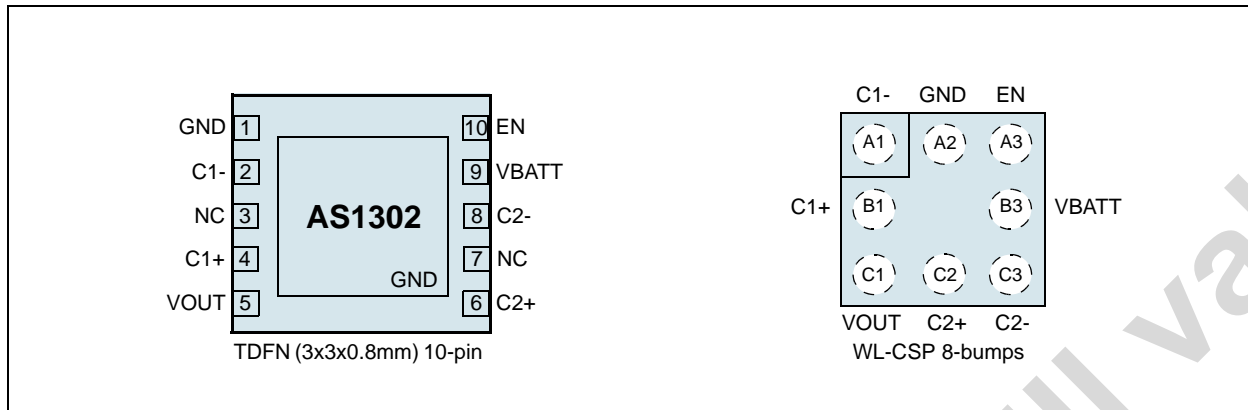

Pin Descriptions

Table 1. Pin Descriptions

Pin Name	Pin Number	Description
C1-	A1	Connector 1- . Negative terminal of flying cap 1.
GND	A2	Ground.
EN	A3	Enable. (operating if EN = 1). Set this digital input to logic high for normal operation. For shutdown, set to logic low.
C1+	B1	Connector 1+. Positive terminal of flying cap 1.
VBATT	B3	+2.9V to 5.15V Input Voltage. Bypass this pin to GND with a $\geq 2.2\mu\text{F}$ low ESR ceramic capacitor.
VOUT	C1	+5V Output Voltage. This pin must be bypassed with a $\geq 2.2\mu\text{F}$ low ESR ceramic capacitor.
C2+	C2	Connector 2+. Positive terminal of flying cap 2.
C2-	C3	Connector 2- . Negative terminal of flying cap 2.

5 Absolute Maximum Ratings

Stresses beyond those listed in [Table 2](#) may cause permanent damage to the device. These are stress ratings only, and functional operation of the device at these or any other conditions beyond those indicated in [Section 6 Electrical Characteristics on page 4](#) is not implied. Exposure to absolute maximum rating conditions for extended periods may affect device reliability.

Table 2. Absolute Maximum Ratings

Parameter	Min	Max	Units	Notes
All pins to GND	-0.3	+7.0	V	
Operating Temperature Range	-40	+85	°C	
Storage Temperature Range	-65	+125	°C	
ESD	2		kV	HBM MIL-Std. 883E 3015.7 methods
	500		V	CDM JESD22-C101C methods
Package Body Temperature	+260		°C	The reflow peak soldering temperature (body temperature) specified is in accordance with IPC/JEDEC J-STD-020D "Moisture/Reflow Sensitivity Classification for Non-Hermetic Solid State Surface Mount Devices". The lead finish for Pb-free leaded packages is matte tin (100% Sn).

6 Electrical Characteristics

$V_{BATT} = 2.9V$ to $5.15V$, $V_{OUT} = 5V$, $C_{OUT} = C_{BAT} = 2.2\mu F$, $C_{FLY1} = C_{FLY2} = 220nF$, $T_{AMB} = -40$ to $+85^{\circ}C$. Typical values are at $T_{AMB} = +25^{\circ}C$ and $V_{IN} = 3.3V$, unless otherwise specified.

Table 3. Electrical Characteristics

Symbol	Parameter	Conditions	Min	Typ	Max	Units
$V_{BATT(on)}$	Undervoltage Lockout	Rising V_{BATT}		2.8	2.9	V
$V_{BATT(off)}$	Undervoltage Lockout	Falling V_{BATT}	2.4	2.5	2.8	V
V_{BATT}	Battery Supply Voltage		2.9		5.15	V
V_{OUT}	Output Voltage Accuracy	$I_{OUT} = 0mA, 15mA$	4.85	5.0	5.15	V
$\Delta V_O/\Delta I_{O11}$	Load Regulation in 1:1 Mode	$V_{BATT} = 5.4V, I_{OUT} = 10\sim 30mA$		2		mV/mA
$\Delta V_O/\Delta I_{O23}$	Load Regulation in 2:3 Mode	$V_{BATT} = 4.3V, I_{OUT} = 10\sim 30mA$		3		
$\Delta V_O/\Delta I_{O12}$	Load Regulation in 1:2 Mode	$V_{BATT} = 3.3V, I_{OUT} = 10\sim 30mA$		3		
$V_{tgr11/23}$	Mode Switching Voltage	1:1 / 2:3 mode, falling V_{BATT}		5.1		V
$V_{tgr23/12}$		2:3 / 1:2 mode, falling V_{BATT}		3.6		
		Mode switching voltage hysteresis			150	
I_{OUT}	Load Current ¹				30	mA
V_{ripple}	Output Voltage Ripple	$V_{BATT} = 3.6V, I_{OUT} = 30mA$		22		mV _{PP}
		$V_{BATT} = 3.6V, I_{OUT} = 2mA$		40		mV _{PP}
I_{inr}	Inrush Current ²				150	mA
I_{short}	Short-Circuit Current				150	mA
η_{12}	Efficiency in Switching Mode	1:2 mode, $V_{BATT} = 2.9V$, $I_{OUT} = 30mA$		85		%
η_{23}		2:3 mode, $V_{BATT} = 3.8V$, $I_{OUT} = 30mA$		85		%
I_{OP12}	Operating Quiescent Current	$V_{BATT} = 3.4V$ (1:2 mode without load)		240	300	μA
I_{OP23}		$V_{BATT} = 4.5V$ (2:3 mode without load)		170	230	
I_{OP11}		$V_{BATT} = 5.3V$ (1:1 mode without load)		100	150	
I_{OFF}	Shutdown Current	$EN = 0V$		0.01	1	μA
Input Levels						
V_{IH}	Input High Level	pin EN	1.1		5.5	V
V_{IL}	Input Low Level		0.0		0.4	V
Timing						
f _{OSC}	Oscillator Frequency	$V_{BATT} = 3.6V, I_{OUT} = 30mA$	0.9	1.2	1.5	MHz
		$V_{BATT} = 3.6V, I_{OUT} = 2mA$	40	49	65	kHz
t _{START}	Startup Time			0.5	1	ms
Thermal Regulation						
T _{OFF}	Temperature Shutdown	Temperature rising		145		$^{\circ}C$
		Hysteresis		10		

1. The device is tested in a proprietary test mode.
2. The inrush current is limited by the internal soft-start circuitry.

Note: All limits are guaranteed. The parameters with min and max values are guaranteed with production tests or SQC (Statistical Quality Control) methods.

7 Typical Operating Characteristics

$V_{BAT} = 3.3V$, $V_{OUT} = 5V$, $C_{OUT} = C_{BAT} = 2.2\mu F$, $C_{FLY1} = C_{FLY2} = 220nF$, $T_{AMB} = +25^{\circ}C$, unless otherwise specified.

Figure 3. Efficiency vs. Input Voltage; $I_{LOAD} = 1mA$

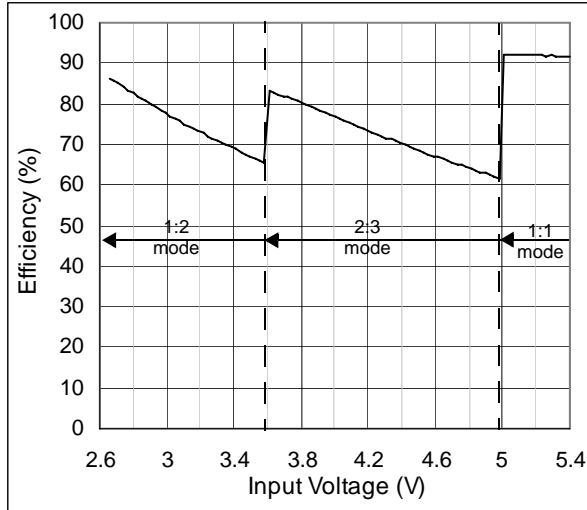

Figure 4. Efficiency vs. Input Voltage; $I_{LOAD} = 10mA$

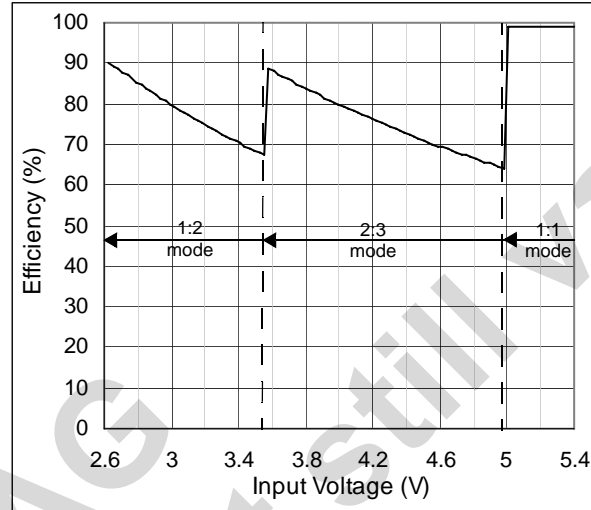

Figure 5. Efficiency vs. Input Voltage; $I_{LOAD} = 20mA$

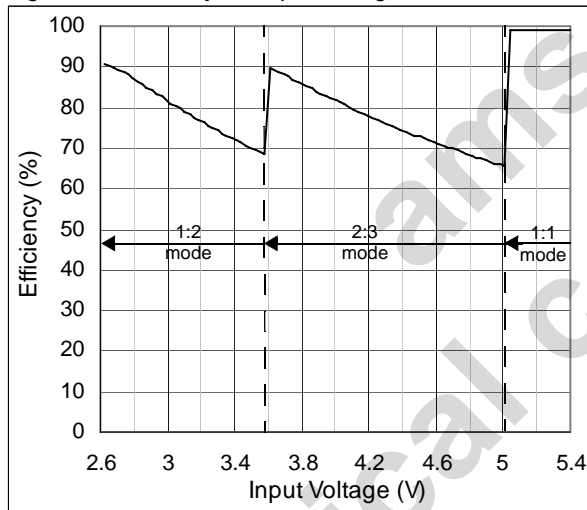

Figure 6. Efficiency vs. Input Voltage; $I_{LOAD} = 30mA$

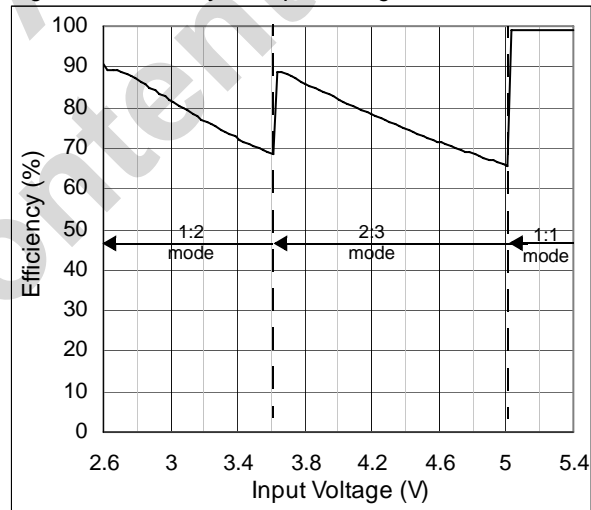

Figure 7. Quiescent Current vs. Input Voltage

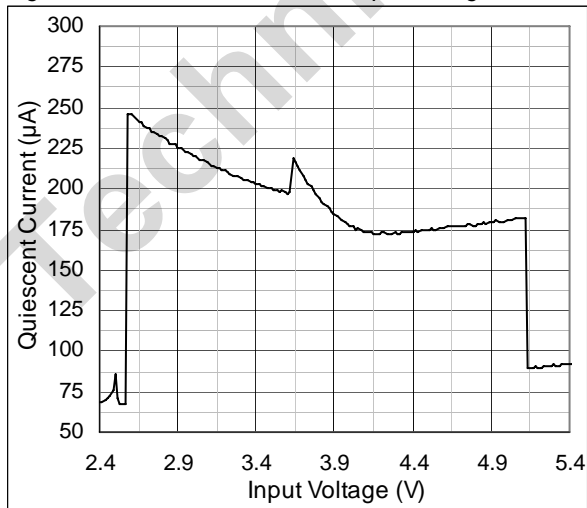

Figure 8. Quiescent Current vs. Temperature

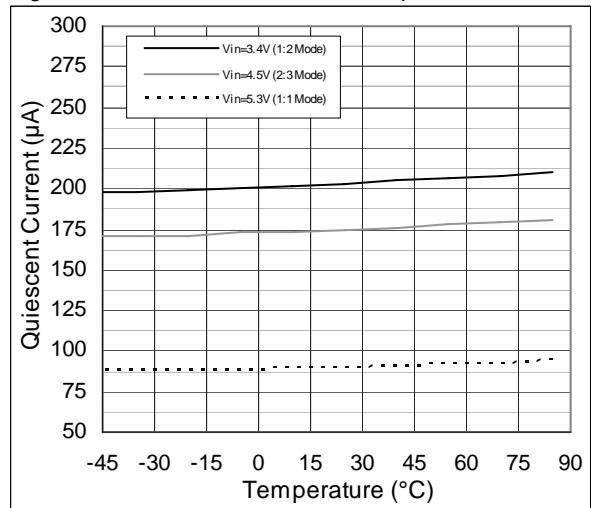

Figure 9. Efficiency vs. Output Current; $V_{BATT} = 2.9V$

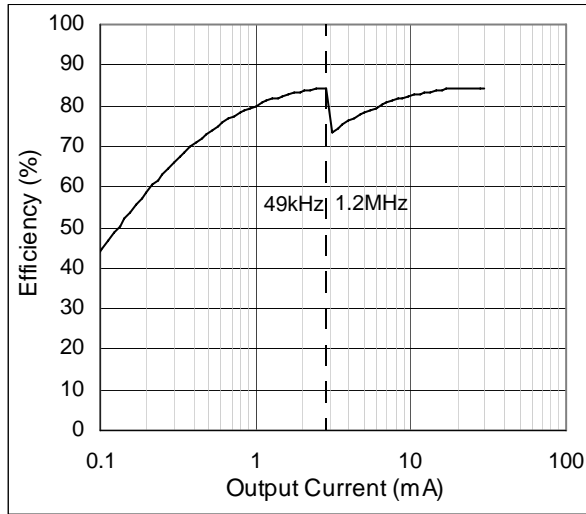

Figure 10. Efficiency vs. Output Current; $V_{BATT} = 3.3V$

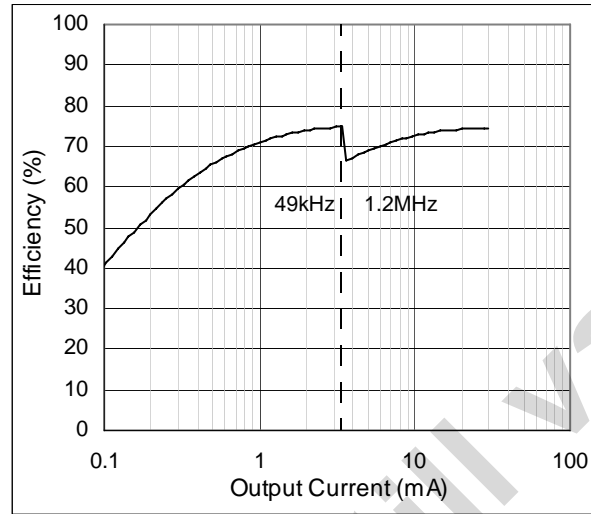

Figure 11. Efficiency vs. Output Current; $V_{BATT} = 3.6V$

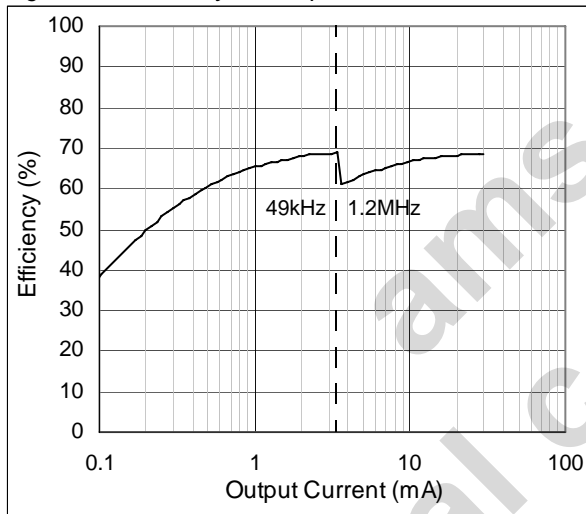

Figure 12. Efficiency vs. Output Current; $V_{BATT} = 4V$

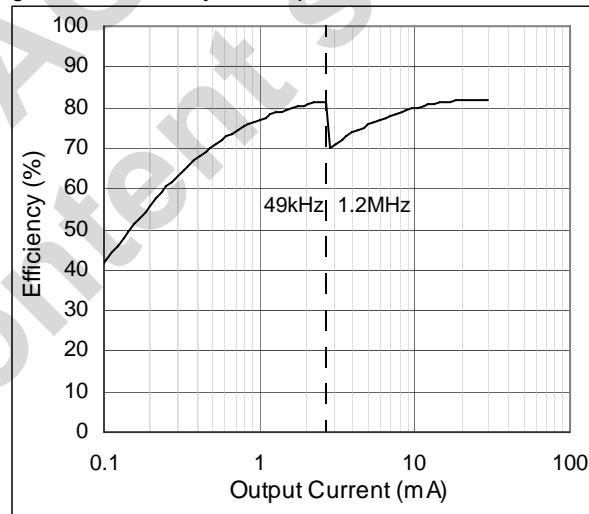

Figure 13. Efficiency vs. Output Current; $V_{BATT} = 4.3V$

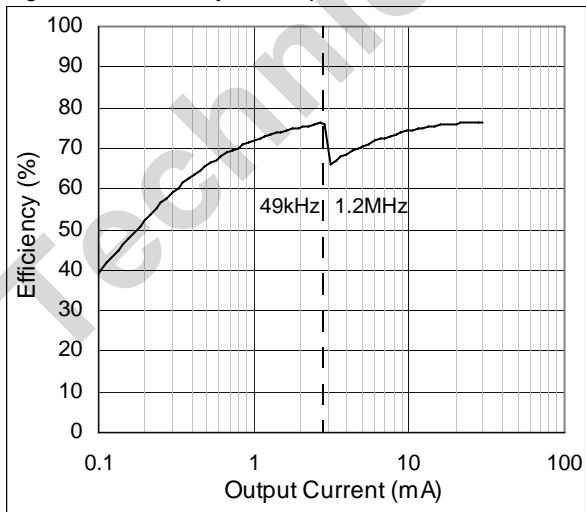

Figure 14. Efficiency vs. Output Current; $V_{BATT} = 5.4V$

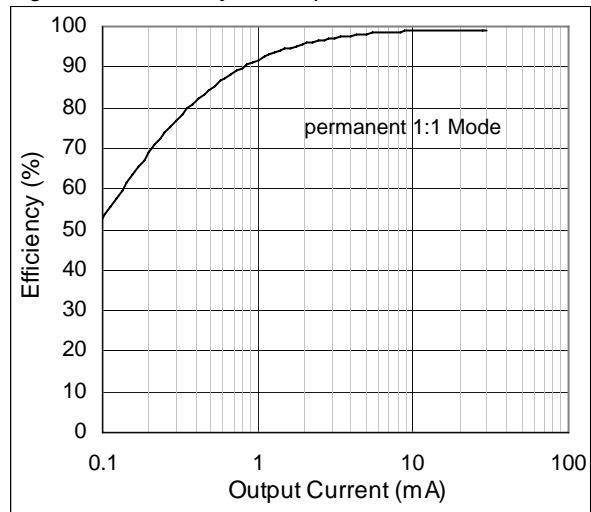

Figure 15. Output Voltage vs. Output Current

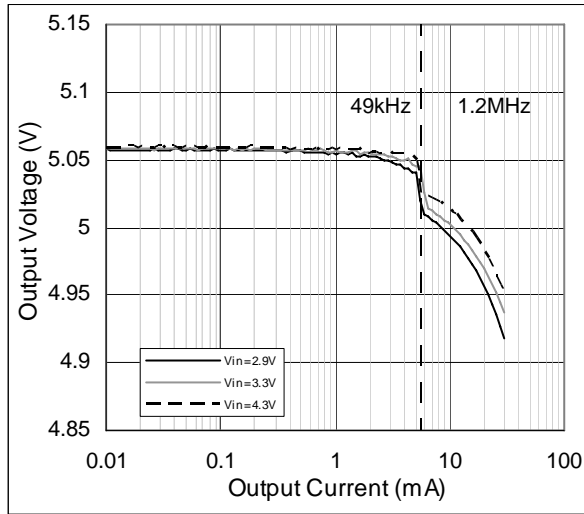

Figure 16. Output Voltage vs. Output Current

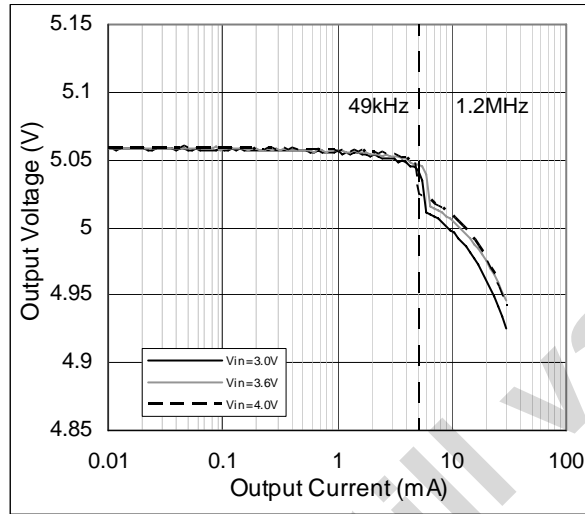

Figure 17. Output Voltage vs. Input Voltage

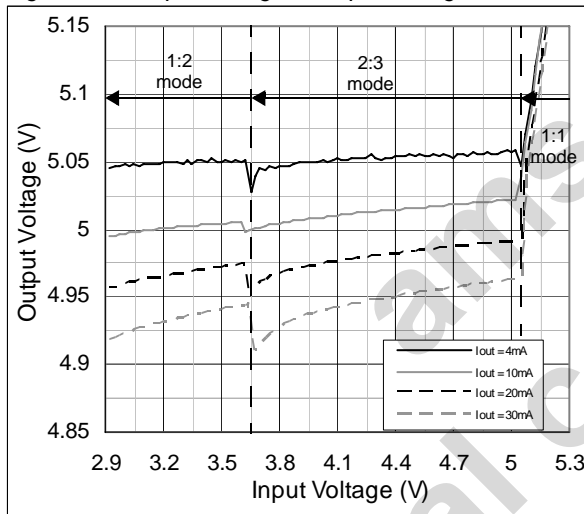

Figure 18. Output Voltage vs. Temperature

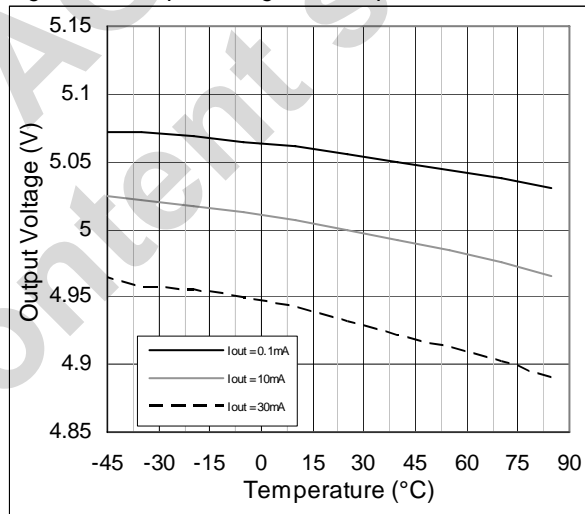

Figure 19. Startup Time vs. Input Voltage; load=166Ω

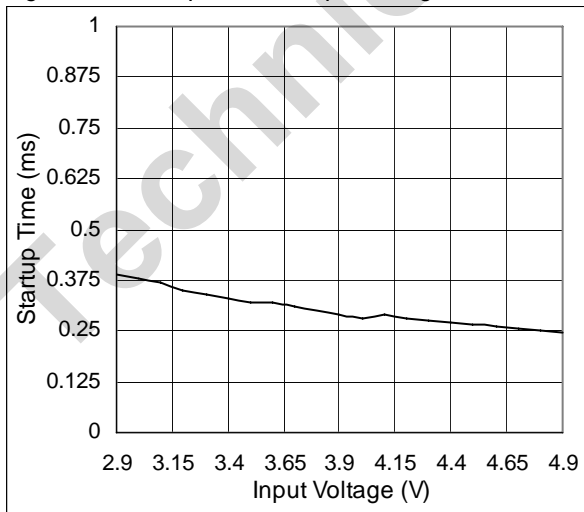

Figure 20. Turn-ON / Turn-OFF Time @ load = 166Ω

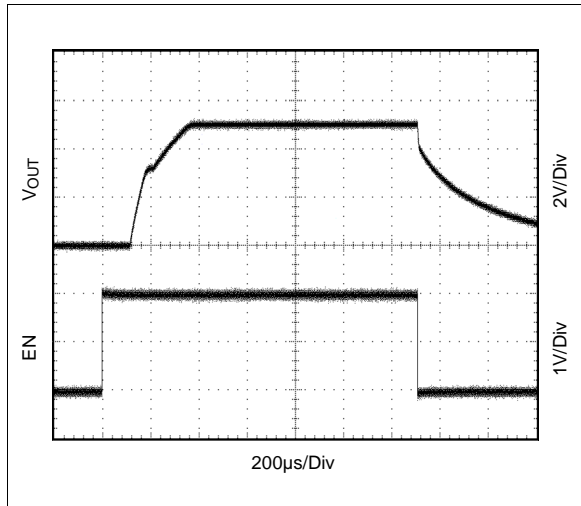

Figure 21. Inrush Current; no load

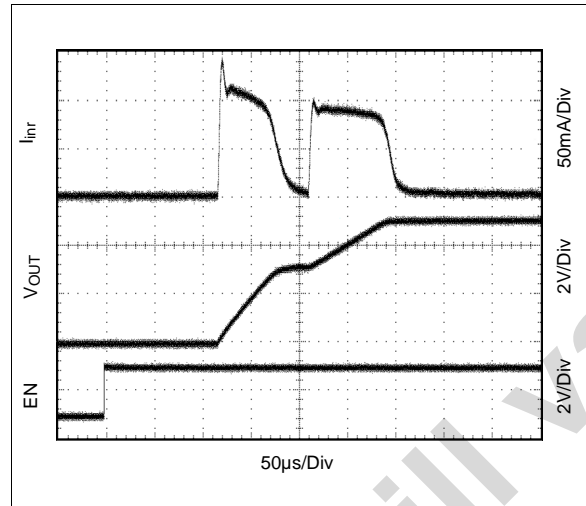

Figure 22. Switching Frequency vs. Input Voltage; $I_{OUT} = 2mA$

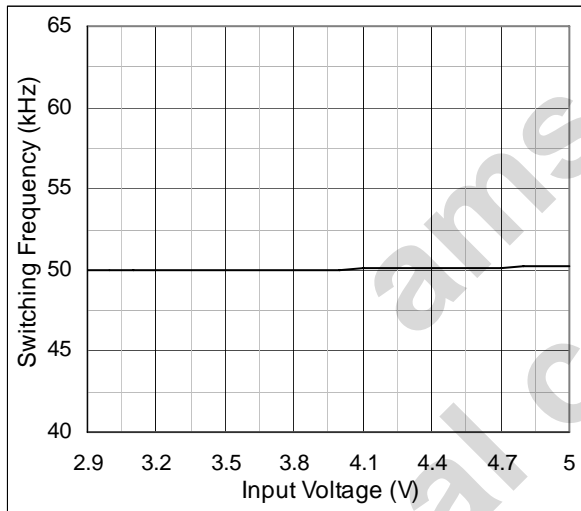

Figure 23. Switching Frequency vs. Input Voltage; $I_{OUT} = 20mA$

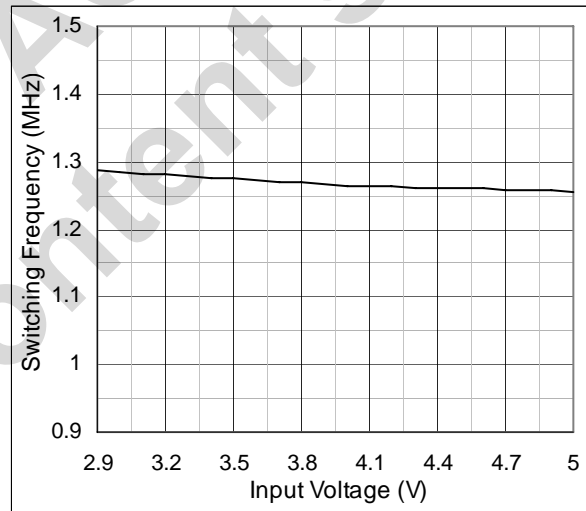

Figure 24. Switching Frequency vs. Temperature; $I_{OUT} = 2mA$

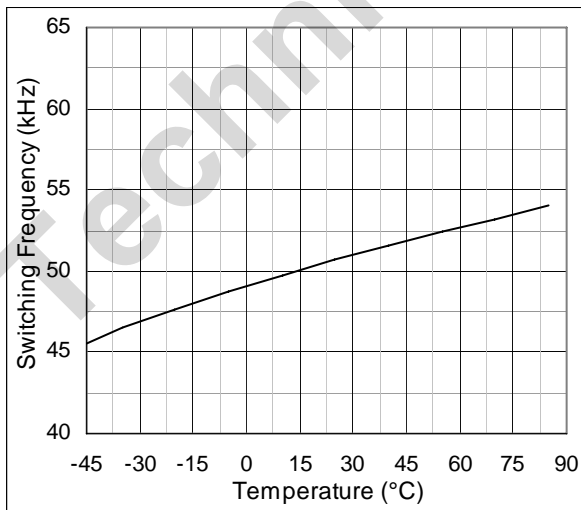

Figure 25. Switching Frequency vs. Temperature; $I_{OUT} = 20mA$

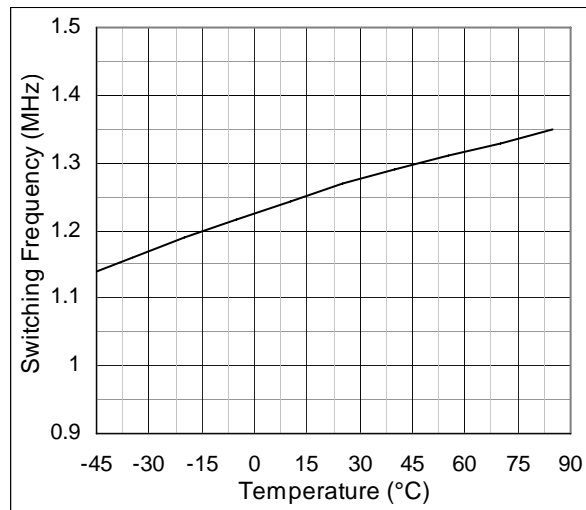

Figure 26. Load Transient; Mode = 1:1,
 $I_{OUT} = 30$ to 10 to 30 mA

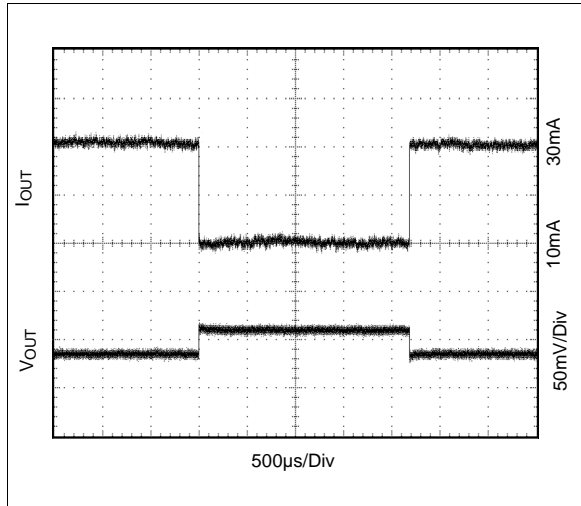

Figure 27. Load Transient; Mode = 2:3,
 $I_{OUT} = 30$ to 10 to 30 mA

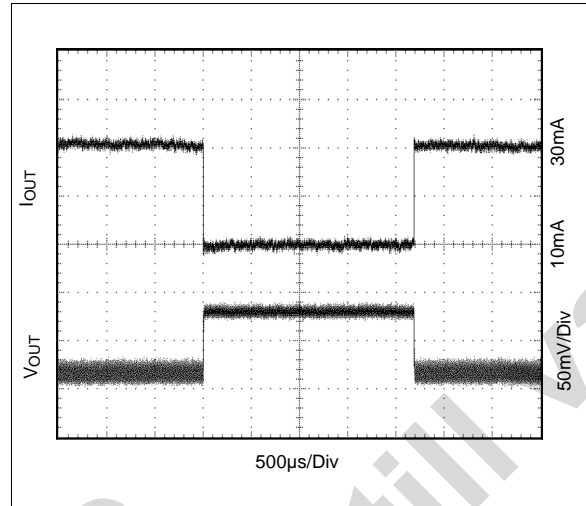

Figure 28. Load Transient; Mode = 1:2,
 $I_{OUT} = 30$ to 10 to 30 mA

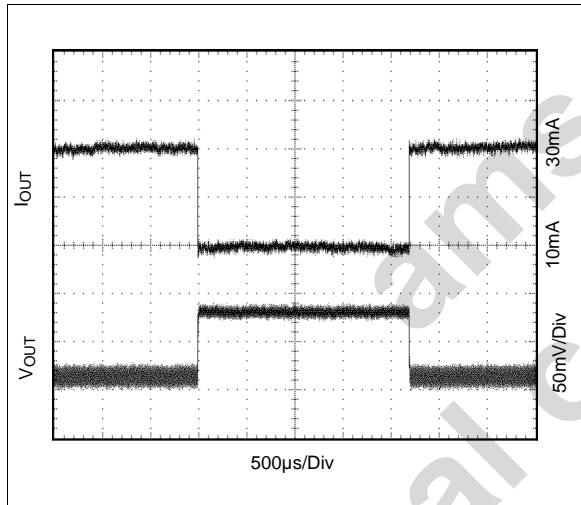

Figure 29. Load Transient; Mode = 1:2,
 $I_{OUT} = 20$ to 4 to 20 mA

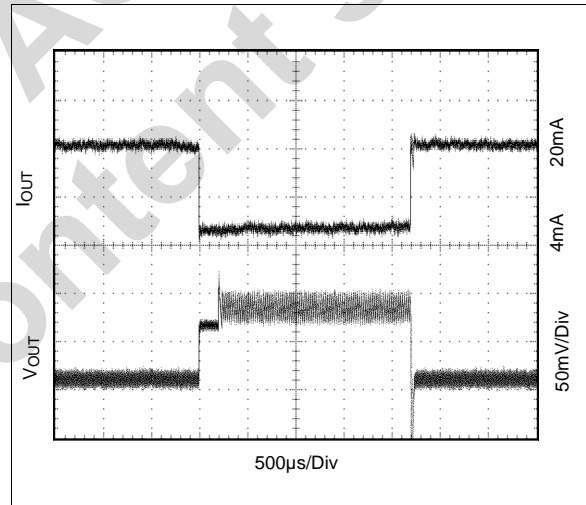

Figure 30. Line Transient

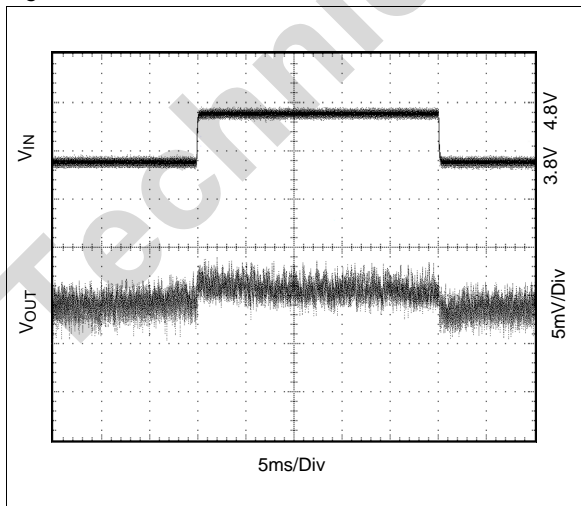
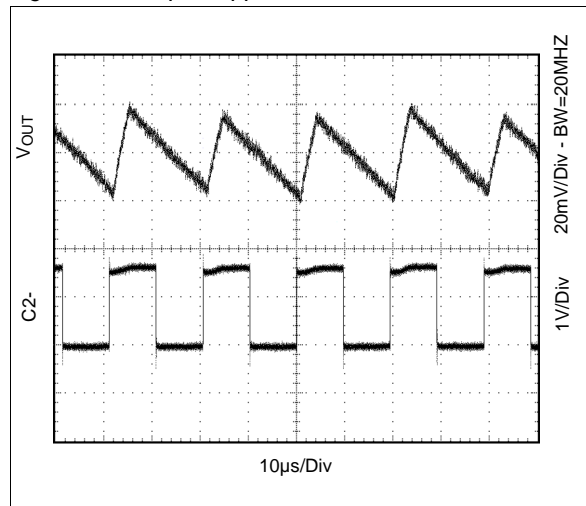

Figure 31. Output Ripple



8 Detailed Description

Functional Description

The AS1302 is a high efficiency and low noise switched capacitor DC-DC converter that is capable of boost operation. It is equipped with two built-in coupled H-bridge type switch configurations. Based on the value of the output voltage the system automatically initiates mode-switching to achieve the highest possible efficiency. The regulation of the output voltage is achieved by a regulation loop, which modulates the current drive capability of the power transistors so that the amount of charge transferred from the input to the output at each clock cycle is controlled and is equal to the charge needed by the load.

Regulation Loop

The AS1302 operates at a constant frequency. For the regulation loop power transistors, a resistor divider and an error amplifier are used to keep the output voltage within the allowed limits. The error amplifier takes the feedback and reference signals as inputs and generates the error voltage signal. The error voltage controls a driver that triggers the gate voltage of the power transistor which modulates the current drive capability of the power amplifier. The modulated transistor controls the charge transferred from the input to the output and therefore the regulation of the output is realized. This regulation concept which is based on adjusting the amount of charge transferred, delivers the smallest voltage ripple possible.

Figure 32. AS1302 - Functional Block Diagram

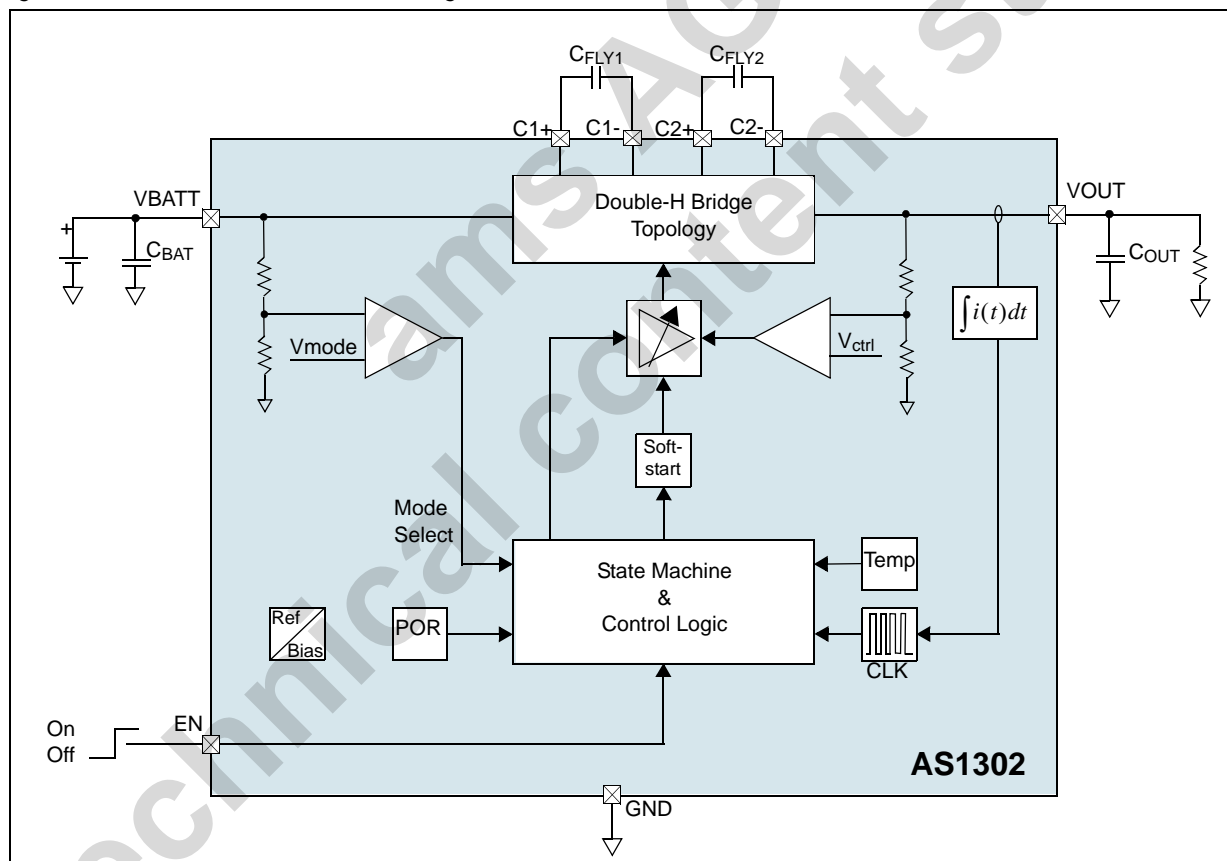

Light/Heavy Load Monitor

To detect the output current in the 2:3 and in the 1:2 mode, a current sense is used. The device switches to a lower switching frequency (49kHz typ), due to a detected light-load condition. With this frequency an excellent light-load efficiency is achieved and no audible noise is generated. If the load is increasing (typically more than 3mA), the device operates at 1.2MHz.

Switch Configuration

The AS1302 has nine built-in power switches in the shape of two coupled H-bridge topologies. The system features 1:2 and 2:3 operation modes as well as a 1:1 operation where the input is directly connected to the output.

In 2:3 operation mode two flying capacitors are placed in series and each capacitor is charged to the half of the input voltage. In pumping phase the flying capacitors are placed in parallel. The bottom-plates of the parallel flying capacitors C_{FLY1} and C_{FLY2} are connected to the input voltage so that the voltage at the top-plates of the flying capacitors is boosted to a voltage equal to $V_{BATT} + V_{BATT}/2$. By connecting the top-plates of the capacitors to the output, the output voltage in the 2:3 mode can be up to one and a half of V_{BATT} . If the top-plate voltage is higher than 5V, the regulation loop adapts the power transistor's on-resistance to drop some voltage.

Figure 33. 2:3 Operating Mode

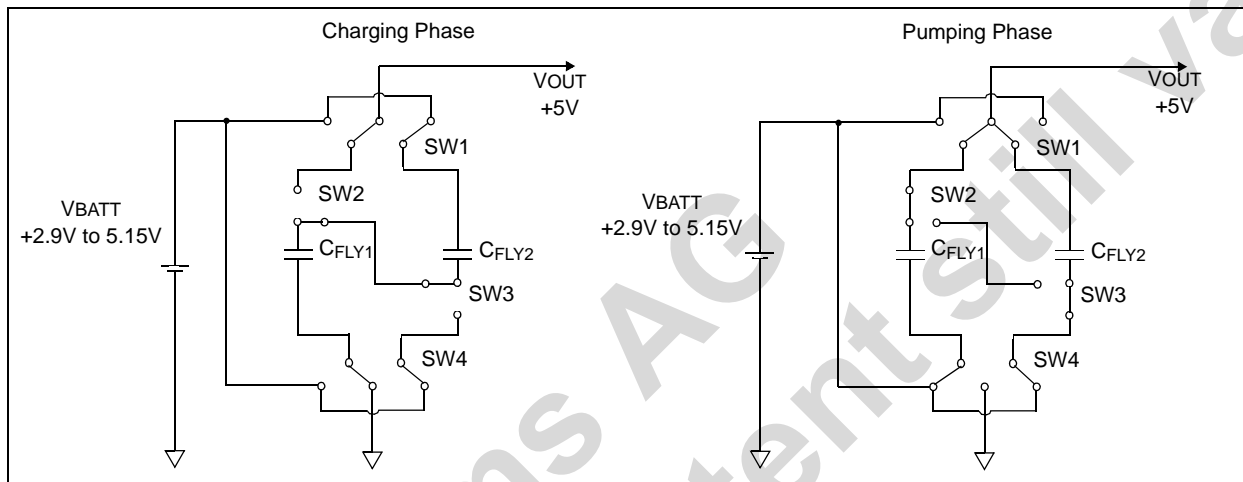

In 1:2 operation both flying capacitors are placed in parallel to the input voltage, and therefore charged to the input voltage. During pumping phase the input voltage is connected to the bottom of the charged flying capacitors. The voltage at the top-plates of the parallel capacitors is now boosted to $2V_{BATT}$. By connecting the top-plates of the capacitors to the output, the output can be charged to twice the voltage of V_{BATT} . If the top-plate voltage is higher than 5V the regulation loop limits the charge transfer to the output.

Figure 34. 1:2 Operating Mode

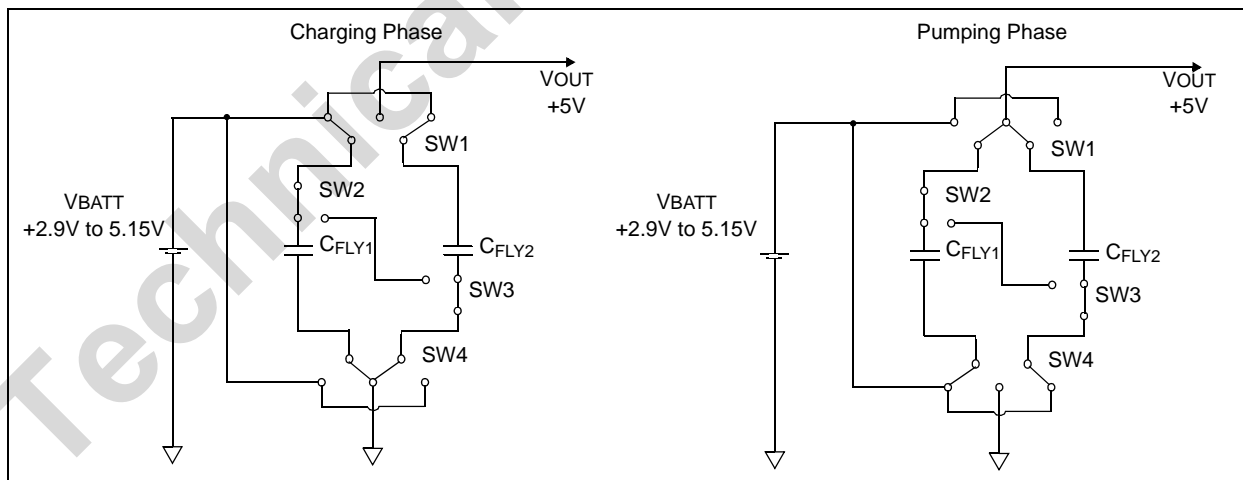

Soft-start

The soft-start circuit prevents the supply from high inrush currents caused by the converter's power-up sequence. During the soft-start (0.5ms typ) the device limits the inrush current. The device is capable to power-up at the minimum specified battery voltage and with the maximum load (ohmic equivalent) applied to the output.

Undervoltage Lockout, UVLO

The AS1302 is equipped with an undervoltage lockout functionality. If the battery voltage drops below 2.5V (typ) the device enters the undervoltage lockout condition. The device remains in this condition until the battery voltage is high enough to enter the soft start sequence. An internal hysteresis of 300mV prevents ringing during startup. If the input voltage increases to 2.8V (typ) again after such a condition the device turns-on automatically.

Shutdown Mode

The AS1302 enters low-power shutdown mode when EN is set to logic low. In shutdown the charge-pump action is halted, the output is completely disconnected from the input and V_{OUT} will drop to 0V.

Note: For a stable operation trigger at least a rising edge on the EN pin to set the internal settings of the device after V_{BATT} power-up.

Short-Circuit Protection

Short-circuit protection prevents damage to the device if the output is shorted to ground. Whenever the output voltage is pulled significantly below V_{BATT}, short-circuit protection is triggered and limits the current. As soon as V_{OUT} recovers the protection is released and the device enters soft-start mode.

Thermal Shutdown

The AS1302 offers thermal shutdown, which prevents damage due to an over-temperature condition. Thermal shutdown will be initiated if the junction temperature exceeds 145°C. If the temperature drops below this value, the thermal shutdown will be released automatically and the device resumes operation. A hysteresis prevents the thermal shutdown from oscillating.

Efficiency Consideration

In the 2:3 operation mode the input current of the charge pump is approximately 1.5x the load current. In an ideal charge pump the efficiency can be calculated by:

$$\eta = \frac{P_{OUT}}{P_{IN}} = \frac{V_{OUT} \times I_{OUT}}{V_{BATT} \times 1,5 I_{OUT}} = \frac{V_{OUT}}{1,5 V_{BATT}} \quad (EQ 1)$$

The same works for the 1:2 operation mode. The input current of the charge pump is approximately 2x the load current. The efficiency of a charge pump in 1:2 operation mode can be calculated by:

$$\eta = \frac{P_{OUT}}{P_{IN}} = \frac{V_{OUT} \times I_{OUT}}{V_{BATT} \times 2 I_{OUT}} = \frac{V_{OUT}}{2 V_{BATT}} \quad (EQ 2)$$

For typical and high output power conditions the quiescent current and the switching losses are negligible and (EQ 1) and (EQ 2) are valid. Hence, with the same input Voltage the 2:3 operation mode will result into a higher efficiency than the 1:2 operation mode.

9 Application Information

External Component Selection

The high internal oscillator frequency of 1.2MHz permits the use of small capacitors for both, the flying capacitors and the output capacitors. For any given load the value of the flying- and output capacitors as well as their ESR are affecting the output voltage performance.

In general, the capacitor's ESR is inversely proportional to its physical size. Larger capacitances and higher voltage ratings tend to reduce ESR. The ESR is a function of the frequency too, so it must be rated at the devices operating frequency. Another factor affecting capacitor ESR is temperature.

Note: Many capacitors have a huge capacity variation over temperature. This can be compensated by choosing a capacitor with a better thermal coefficient or by choosing a larger nominal value to ensure proper operation over temperature.

It is not critical which type of input bypass capacitor C_{BAT} and output filter capacitor C_{OUT} is used, but it will affect the performance of the charge pump. Low ESR capacitors should be used to minimize V_{OUT} ripple. Multi-layer ceramic capacitors are recommended since they have extremely low ESR and are available in small footprints.

Input Capacitor

A 2.2 μ F input bypass low ESR capacitor such as tantalum or ceramic is recommended to reduce noise and supply transients. During startup and mode change it supplies a part of the peak input current drawn by the device.

Output Capacitor

The output capacitor is charged to V_{OUT} during the pumping phase. The ESR of the output capacitor introduces spikes in the output voltage waveform whenever the charge pump charges C_{OUT} . These spikes contribute to the ripple voltage of V_{OUT} . Therefore, ceramic or tantalum low ESR capacitors are recommended for C_{OUT} to minimize the output voltage ripple.

Table 4. Recommended Input and Output Capacitors

Part Number	C	TC Code	Rated Voltage	Dimensions	Manufacturer
GRM188R61C225KE15	2.2 μ F	X5R	16V	0603	Murata www.murata.com
GRM21BR71E225KA73	2.2 μ F	X7R	25V	0805	
GRM188R60J475KE19	4.7 μ F	X5R	6.3V	0603	
GRM188R60J106ME47	10 μ F	X5R	6.3V	0603	

Figure 35. Load Regulation Comparison with different Capacitors

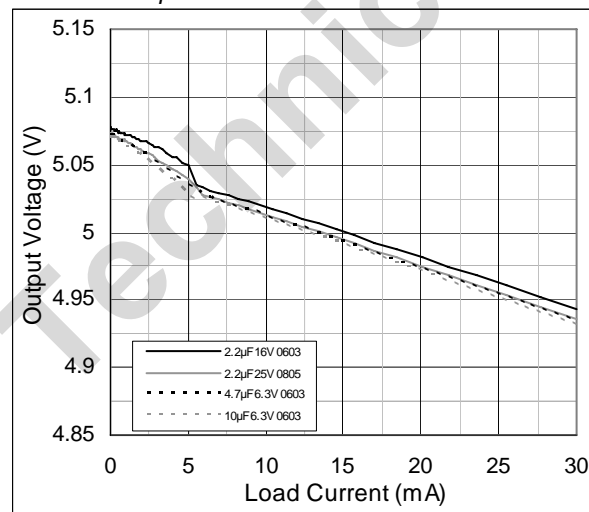
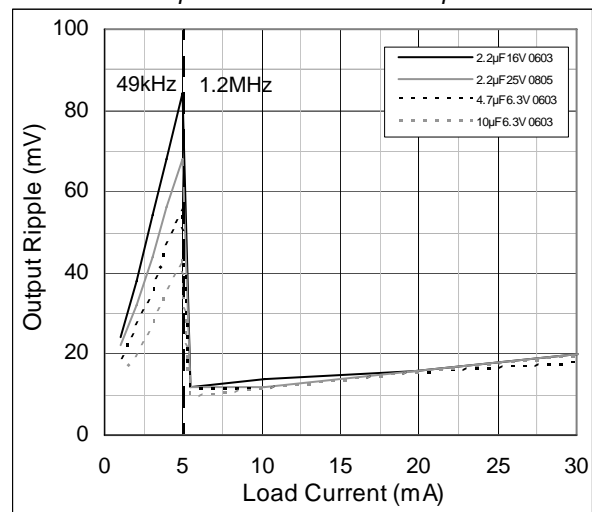

Figure 36. Output Ripple vs. Output Current Comparison with different Capacitors



Flying Capacitor Selection

To ensure the required output current and avoid high peak currents the values of the flying capacitors C_{FLY1} and C_{FLY2} are very critical. A 220nF capacitor is sufficient for most applications. Dependent on the operation mode the AS1302 alternately charges and discharges the C_{FLY1/2}. While the ESR of the output capacitor produces a part of the output voltage ripple, the ESR of the flying capacitors directly adds to the charge pump's output source resistance. Therefore low ESR capacitors, e.g. tantalum or ceramic, are recommended for the flying capacitors as well.

Due to different materials for ceramic capacitors the on the material depending temperature and voltage coefficients have to be considered. The capacitance of a X7R ceramic capacitor is more stable than a Z5U or Y5V ceramic capacitor over the whole temperature range from -40°C to +85°C. As an additional effect a Z5U or Y5V ceramic capacitor will loose about the half of his nominal capacitance when the rated voltage is applied.

It is important to choose the ceramic capacitor according to the minimum available capacitance over the operating voltage and the bias voltage. This information is stated in the datasheets of the capacitor manufacturer.

Table 5. Recommended Flying Capacitors

Part Number	C	TC Code	Rated Voltage	Dimensions	Manufacturer
GRM188R71E224KA88	220nF	X7R	25V	0603	Murata www.murata.com
GRM155R61A224KE19	220nF	X5R	10V	0402	

Layout Consideration

To achieve the best performance of the AS1302 a careful board layout is necessary to reduce the impact of the high switching frequency and the high transient currents which are produced by the device. For a proper regulation under all conditions a true ground plane and short connections to all external capacitors are needed.

10 Package Drawings and Markings

The device is available in a TDFN (3x3x0.8mm) 10-pin and WL-CSP 8-bumps package.

Figure 37. TDFN (3x3x0.8mm) 10-pin Package Diagram

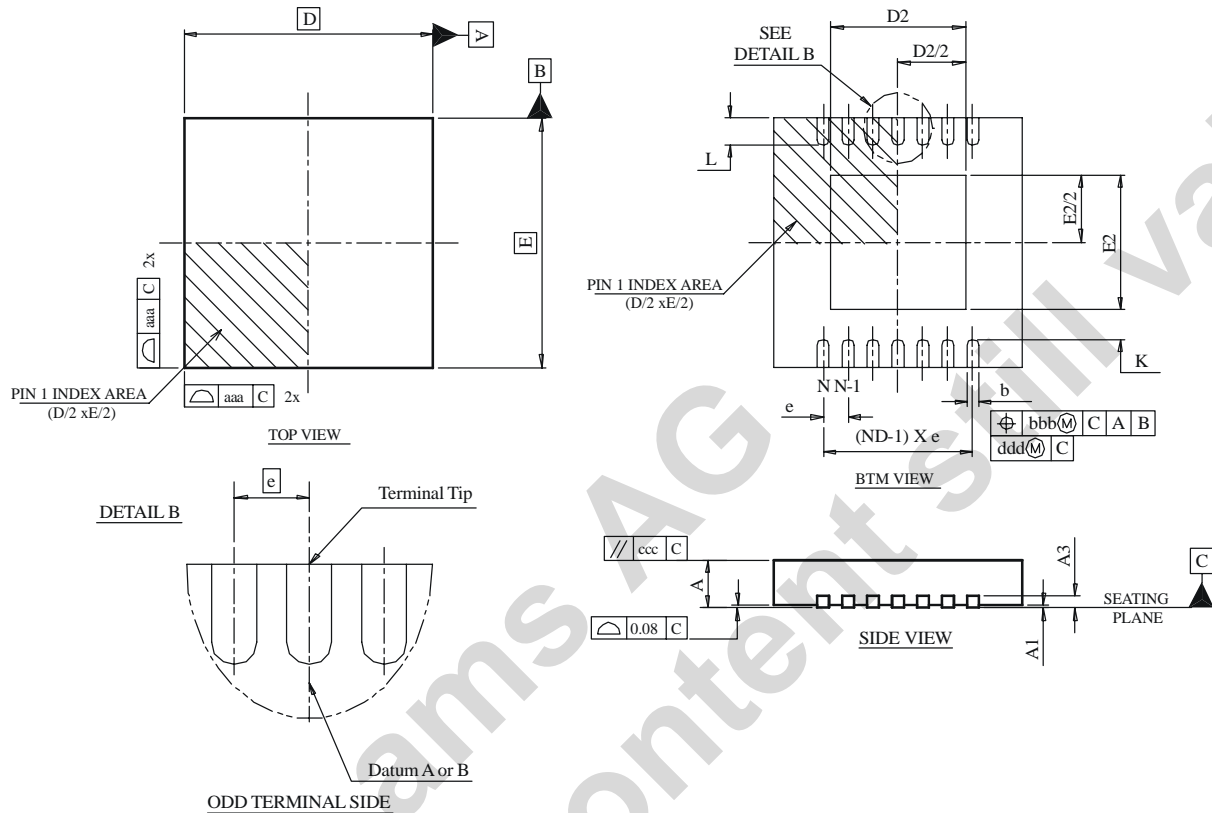

Table 6. TDFN (3x3x0.8mm) 10-pin Package Dimensions

Symbol	Min	Typ	Max	Symbol	Min	Typ	Max
A	0.70	0.75	0.80	D BSC		3.00	
A1	0.00	0.02	0.05	E BSC		3.00	
A3		0.20 REF		D2	2.20		2.70
L1	0.03		0.15	E2	1.40		1.75
L2			0.13	L	0.30	0.40	0.50
aaa		0.15		θ	0°		
bbb		0.10		k	0.20		
ccc		0.10		b	0.18	0.25	0.30
ddd		0.05		e		0.50	
eee		0.08		N		10	
ggg		0.10		ND		5	

Note:

- Figure 37 is shown for illustration only.
- N is the total number of terminals.
- All dimensions are in millimeters, angle is in degrees.
- Dimensioning and tolerancing conform to ASME Y14.5M-1994.

Figure 38. WL-CSP 8-bumps Package Diagram

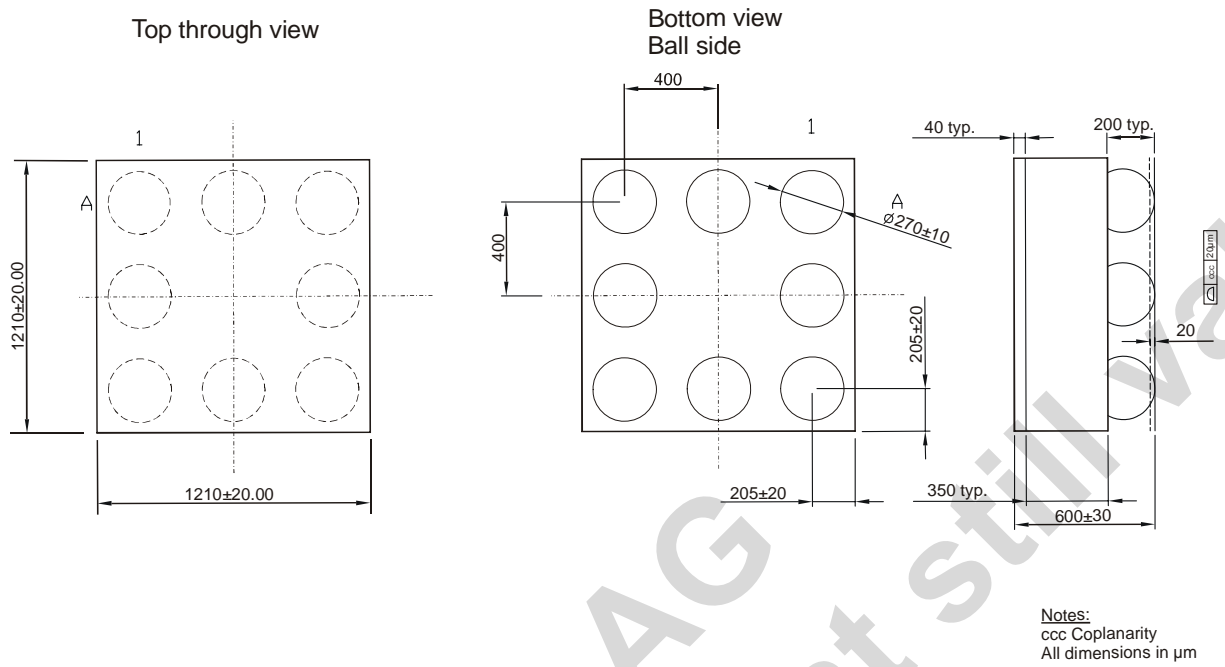

11 Ordering Information

The device is available as the standard products shown in [Table 7](#).

Table 7. Ordering Information

Ordering Code	Marking	Description	Delivery Form	Package
AS1302-BWLT	ASQ7	5V/30mA Adaptive Inductorless Boost Converter	Tape and Reel	WL-CSP 8-bumps
AS1302-BTDT	ASQ7	5V/30mA Adaptive Inductorless Boost Converter	Tape and Reel	TDFN (3x3x0.8mm) 10-pin

Note: All products are RoHS compliant and Pb-free.

Buy our products or get free samples online at ICdirect: <http://www.austriamicrosystems.com/ICdirect>

For further information and requests, please contact us <mailto:sales@austriamicrosystems.com> or find your local distributor at <http://www.austriamicrosystems.com/distributor>

Copyrights

Copyright © 1997-2010, austriamicrosystems AG, Tobelbaderstrasse 30, 8141 Unterpremstaetten, Austria-Europe. Trademarks Registered ®. All rights reserved. The material herein may not be reproduced, adapted, merged, translated, stored, or used without the prior written consent of the copyright owner.

All products and companies mentioned are trademarks or registered trademarks of their respective companies.

Disclaimer

Devices sold by austriamicrosystems AG are covered by the warranty and patent indemnification provisions appearing in its Term of Sale. austriamicrosystems AG makes no warranty, express, statutory, implied, or by description regarding the information set forth herein or regarding the freedom of the described devices from patent infringement. austriamicrosystems AG reserves the right to change specifications and prices at any time and without notice. Therefore, prior to designing this product into a system, it is necessary to check with austriamicrosystems AG for current information. This product is intended for use in normal commercial applications. Applications requiring extended temperature range, unusual environmental requirements, or high reliability applications, such as military, medical life-support or life-sustaining equipment are specifically not recommended without additional processing by austriamicrosystems AG for each application. For shipments of less than 100 parts the manufacturing flow might show deviations from the standard production flow, such as test flow or test location.

The information furnished here by austriamicrosystems AG is believed to be correct and accurate. However, austriamicrosystems AG shall not be liable to recipient or any third party for any damages, including but not limited to personal injury, property damage, loss of profits, loss of use, interruption of business or indirect, special, incidental or consequential damages, of any kind, in connection with or arising out of the furnishing, performance or use of the technical data herein. No obligation or liability to recipient or any third party shall arise or flow out of austriamicrosystems AG rendering of technical or other services.



Contact Information

Headquarters

austriamicrosystems AG
Tobelbaderstrasse 30
A-8141 Unterpremstaetten, Austria



Tel: +43 (0) 3136 500 0
Fax: +43 (0) 3136 525 01

For Sales Offices, Distributors and Representatives, please visit:

<http://www.austriamicrosystems.com/contact>

Looking for pricing, stock, or lifecycle information?

Click below to explore more details on WIN SOURCE:

-  [View AS1302-BWLT on WIN SOURCE](#)
-  [ams Information](#)

Optimize Your Supply Chain with WIN SOURCE Solutions

-  Global Sourcing Solution
-  Obsolete Management
-  Cost Control Management
-  Shortage Management
-  Alternative Solution
-  Excess Inventory Management