



**THE DATASHEET OF
AD7910ARMZ**



FEATURES

Throughput rate: 250 kSPS

Specified for V_{DD} of 2.35 V to 5.25 V

Low power

3.6 mW typ at 250 kSPS with 3 V supplies

12.5 mW typ at 250 kSPS with 5 V supplies

Wide input bandwidth

71 dB SNR at 100 kHz input frequency

Flexible power/serial clock speed management

No pipeline delays

High speed serial interface

SPI[®]-/QSPI[™]-/MICROWIRE[™]-/DSP-compatible

Standby mode: 1 μ A max

6-lead SC70 package

8-lead MSOP package

APPLICATIONS

Battery-powered systems

Personal digital assistants

Medical instruments

Mobile communications

Instrumentation and control systems

Data acquisition systems

High speed modems

Optical sensors

GENERAL DESCRIPTION

The AD7910/AD7920¹ are, respectively, 10-bit and 12-bit, high speed, low power, successive approximation ADCs. The parts operate from a single 2.35 V to 5.25 V power supply and feature throughput rates up to 250 kSPS. The parts contain a low noise, wide bandwidth track-and-hold amplifier that can handle input frequencies in excess of 13 MHz.

The conversion process and data acquisition are controlled using \overline{CS} and the serial clock, allowing the devices to interface with microprocessors or DSPs. The input signal is sampled on the falling edge of \overline{CS} and the conversion is initiated at this point. There are no pipeline delays associated with the part.

The AD7910/AD7920 use advanced design techniques to achieve very low power dissipation at high throughput rates.

The reference for the part is taken internally from V_{DD} . This allows the widest dynamic input range to the ADC. Thus, the analog input range for the part is 0 to V_{DD} . The conversion rate is determined by the SCLK.

Rev. C

Information furnished by Analog Devices is believed to be accurate and reliable. However, no responsibility is assumed by Analog Devices for its use, nor for any infringements of patents or other rights of third parties that may result from its use. Specifications subject to change without notice. No license is granted by implication or otherwise under any patent or patent rights of Analog Devices. Trademarks and registered trademarks are the property of their respective owners.

FUNCTIONAL BLOCK DIAGRAM

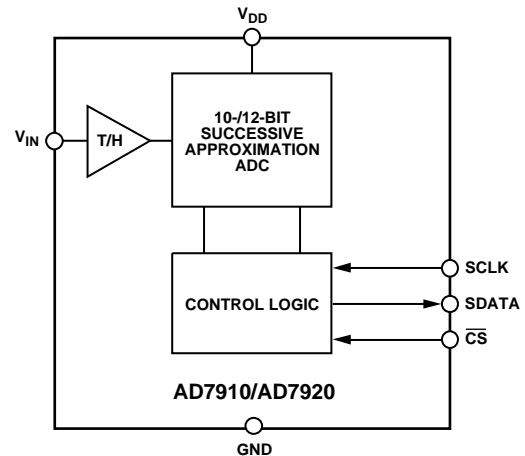

Figure 1.

02976-001

PRODUCT HIGHLIGHTS

1. 10-/12-bit ADCs in SC70 and MSOP packages.
2. Low power consumption.
3. Flexible power/serial clock speed management. The conversion rate is determined by the serial clock, allowing the conversion time to be reduced through the serial clock speed increase. This allows the average power consumption to be reduced when power-down mode is used while not converting. The part also features a power-down mode to maximize power efficiency at lower throughput rates. Current consumption is 1 μ A maximum and 50 nA typically when in power-down mode.
4. Reference derived from the power supply.
5. No pipeline delay. The parts feature a standard successive approximation ADC with accurate control of the sampling instant via a \overline{CS} input and once-off conversion control.

¹ Protected by U.S. Patent No. 6,681,332.

TABLE OF CONTENTS

Features	1	ADC Transfer Function.....	14
Applications.....	1	Typical Connection Diagram	14
Functional Block Diagram	1	Analog Input	15
General Description	1	Digital Inputs	15
Product Highlights	1	Modes of Operation	16
Specifications.....	3	Normal Mode.....	16
AD7910.....	3	Power-Down Mode.....	16
AD7920.....	4	Power-Up Time	16
Timing Specifications	6	Power vs. Throughput Rate.....	18
Timing Examples	7	Serial Interface	19
Timing Example 1	7	Microprocessor Interfacing.....	20
Timing Example 2	7	AD7910/AD7920 to TMS320C541 Interface	20
Absolute Maximum Ratings.....	8	AD7910/AD7920 to ADSP-218x.....	20
ESD Caution.....	8	AD7910/AD7920 to DSP563xx Interface	21
Pin Configurations and Function Descriptions	9	Application Hints	22
Typical Performance Characteristics	10	Grounding and Layout	22
Terminology	12	Evaluating Performance	22
Circuit Information.....	13	Outline Dimensions	23
Converter Operation	14	Ordering Guide	24

REVISION HISTORY

9/05—Rev. B to Rev. C

Updated Formatting	Universal
Updated Outline Dimensions.....	23
Changes to Ordering Guide.....	24

3/04—Rev. A to Rev. B

Added U.S. Patent Number	1
Changes to Note 5	2
Changes to Note 6 of AD7920 Specifications.....	4
Changes to Note 1 of Timing Specifications	4
Changes to Absolute Maximum Ratings	6
Changes to Ordering Guide.....	6

8/03—Rev. 0 to Rev. A

Changes to Ordering Guide.....	6
Changes to Evaluating the AD7910/AD7920 Performance Section.....	18
Updated Outline Dimensions	19

SPECIFICATIONS

AD7910

$V_{DD} = 2.35 \text{ V to } 5.25 \text{ V}$, $f_{SCLK} = 5 \text{ MHz}$, $f_{SAMPLE} = 250 \text{ kSPS}$, $T_A = T_{MIN}$ to T_{MAX} , unless otherwise noted.

Table 1.

Parameter ¹	A Grade ^{1, 2}	Unit	Test Conditions/Comments
DYNAMIC PERFORMANCE			
Signal-to-Noise + Distortion (SINAD) ³	61	dB min	$f_{IN} = 100 \text{ kHz}$ sine wave
Total Harmonic Distortion (THD) ³	-72	dB max	
Peak Harmonic or Spurious Noise (SFDR) ³	-73	dB max	
Intermodulation Distortion (IMD) ³			
Second-Order Terms	-82	dB typ	$f_a = 100.73 \text{ kHz}$, $f_b = 90.7 \text{ kHz}$
Third-Order Terms	-82	dB typ	$f_a = 100.73 \text{ kHz}$, $f_b = 90.7 \text{ kHz}$
Aperture Delay	10	ns typ	
Aperture Jitter	30	ps typ	
Full Power Bandwidth	13.5	MHz typ	@ 3 dB
	2	MHz typ	@ 0.1 dB
DC ACCURACY			
Resolution	10	Bits	
Integral Nonlinearity	± 0.5	LSB max	
Differential Nonlinearity	± 0.5	LSB max	Guaranteed no missed codes to 10 bits
Offset Error ^{3, 4}	± 1	LSB max	
Gain Error ^{3, 4}	± 1	LSB max	
Total Unadjusted Error (TUE) ^{3, 4}	± 1.2	LSB max	
ANALOG INPUT			
Input Voltage Ranges	0 to V_{DD}	V	
DC Leakage Current	± 0.5	μA max	
Input Capacitance	20	pF typ	Track-and-hold in track, 6 pF typ when in hold
LOGIC INPUTS			
Input High Voltage, V_{INH}	2.4	V min	$V_{DD} = 5 \text{ V}$
Input Low Voltage, V_{INL}	0.8	V max	$V_{DD} = 3 \text{ V}$
	0.4	V max	Typically 10 nA, $V_{IN} = 0 \text{ V}$ or V_{DD}
Input Current, I_{IN} , SCLK Pin	± 0.5	μA max	
Input Current, I_{IN} , \overline{CS} Pin	± 10	nA typ	
Input Capacitance, C_{IN}^5	5	pF max	
LOGIC OUTPUTS			
Output High Voltage, V_{OH}	$V_{DD} - 0.2$	V min	$I_{SOURCE} = 200 \mu\text{A}$, $V_{DD} = 2.35 \text{ V to } 5.25 \text{ V}$
Output Low Voltage, V_{OL}	0.4	V max	$I_{SINK} = 200 \mu\text{A}$
Floating-State Leakage Current	± 1	μA max	
Floating-State Output Capacitance ⁵	5	pF max	
Output Coding	Straight (natural) binary		
CONVERSION RATE			
Conversion Time	2.8	μs max	14 SCLK cycles with SCLK at 5 MHz
Track-and-Hold Acquisition Time ³	250	ns max	
Throughput Rate	250	kSPS max	
POWER REQUIREMENTS			
V_{DD}	2.35/5.25	V min/max	Digital I/Ps = 0 V or V_{DD}
I_{DD}			
Normal Mode (Static)	2.5	mA typ	$V_{DD} = 4.75 \text{ V to } 5.25 \text{ V}$, SCLK on or off
	1.2	mA typ	$V_{DD} = 2.35 \text{ V to } 3.6 \text{ V}$, SCLK on or off
Normal Mode (Operational)	3	mA max	$V_{DD} = 4.75 \text{ V to } 5.25 \text{ V}$, $f_{SAMPLE} = 250 \text{ kSPS}$
	1.4	mA max	$V_{DD} = 2.35 \text{ V to } 3.6 \text{ V}$, $f_{SAMPLE} = 250 \text{ kSPS}$
Full Power-Down Mode	1	μA max	Typically 50 nA

AD7910/AD7920

Parameter ¹	A Grade ^{1, 2}	Unit	Test Conditions/Comments
Power Dissipation ⁶			
Normal Mode (Operational)	15	mW max	V _{DD} = 5 V, f _{SAMPLE} = 250 kSPS
	4.2	mW max	V _{DD} = 3 V, f _{SAMPLE} = 250 kSPS
Full Power-Down	5	μW max	V _{DD} = 5 V
	3	μW max	V _{DD} = 3 V

¹ Temperature range from -40°C to +85°C.

² Operational from V_{DD} = 2.0 V, with input high voltage (V_{INH}) 1.8 V min.

³ See the Terminology section.

⁴ SC70 values guaranteed by characterization.

⁵ Guaranteed by characterization.

⁶ See the Power vs. Throughput Rate section.

AD7920

V_{DD} = 2.35 V to 5.25 V, f_{SCLK} = 5 MHz, f_{SAMPLE} = 250 kSPS, T_A = T_{MIN} to T_{MAX}, unless otherwise noted.

Table 2.

Parameter ¹	A Grade ^{1, 2}	B Grade ^{1, 2}	Unit	Test Conditions/Comments
DYNAMIC PERFORMANCE				
Signal-to-Noise + Distortion (SINAD) ³	70	70	dB min	f _{IN} = 100 kHz sine wave V _{DD} = 2.35 V to 3.6 V, T _A = 25°C
	69	69	dB min	V _{DD} = 2.4 V to 3.6 V
	71.5	71.5	dB typ	V _{DD} = 2.35 V to 3.6 V
	69	69	dB min	V _{DD} = 4.75 V to 5.25 V, T _A = 25°C
	68	68	dB min	V _{DD} = 4.75 V to 5.25 V
Signal-to-Noise Ratio (SNR) ³	71	71	dB min	V _{DD} = 2.35 V to 3.6 V, T _A = 25°C
	70	70	dB min	V _{DD} = 2.4 V to 3.6 V
	70	70	dB min	V _{DD} = 4.75 V to 5.25 V, T _A = 25°C
	69	69	dB min	V _{DD} = 4.75 V to 5.25 V
Total Harmonic Distortion (THD) ³	-80	-80	dB typ	
Peak Harmonic or Spurious Noise (SFDR) ³	-82	-82	dB typ	
Intermodulation Distortion (IMD) ³				
Second-Order Terms	-84	-84	dB typ	f _a = 100.73 kHz, f _b = 90.72 kHz
Third-Order Terms	-84	-84	dB typ	f _a = 100.73 kHz, f _b = 90.72 kHz
Aperture Delay	10	10	ns typ	
Aperture Jitter	30	30	ps typ	
Full Power Bandwidth	13.5	13.5	MHz typ	@ 3 dB
	2	2	MHz typ	@ 0.1 dB
DC ACCURACY				
Resolution	12	12	Bits	B Grade ⁴
Integral Nonlinearity ³	±0.75	±1.5	LSB max LSB typ	
Differential Nonlinearity	±0.75	-0.9/+1.5	LSB max LSB typ	Guaranteed no missed codes to 12 bits
Offset Error ^{3, 5}	±1.5	±1.5	LSB max LSB typ	
Gain Error ^{3, 5}	±1.5	±0.2 ±1.5	LSB max LSB typ	
Total Unadjusted Error (TUE) ^{3, 5}	±1.5	±0.5 ±2	LSB max LSB typ	
ANALOG INPUT				
Input Voltage Ranges	0 to V _{DD}	0 to V _{DD}	V	
DC Leakage Current	±0.5	±0.5	μA max	
Input Capacitance	20	20	pF typ	Track-and-hold in track, 6 pF typ when in hold

Parameter ¹	A Grade ^{1,2}	B Grade ^{1,2}	Unit	Test Conditions/Comments
LOGIC INPUTS				
Input High Voltage, V_{INH}	2.4	2.4	V min	$V_{\text{DD}} = 2.35 \text{ V}$ $V_{\text{DD}} = 3.6 \text{ V to } 5.25 \text{ V}$ $V_{\text{DD}} = 2.35 \text{ V to } 3.6 \text{ V}$ Typically 10 nA, $V_{\text{IN}} = 0 \text{ V or } V_{\text{DD}}$
	1.8	1.8	V min	
Input Low Voltage, V_{INL}	0.8	0.8	V max	
	0.4	0.4	V max	
Input Current, I_{IN} , SCLK Pin	± 0.5	± 0.5	$\mu\text{A max}$	
Input Current, I_{IN} , $\overline{\text{CS}}$ Pin	± 10	± 10	nA typ	
Input Capacitance, C_{IN}^6	5	5	pF max	
LOGIC OUTPUTS				
Output High Voltage, V_{OH}	$V_{\text{DD}} - 0.2$	$V_{\text{DD}} - 0.2$	V min	$I_{\text{SOURCE}} = 200 \mu\text{A}$, $V_{\text{DD}} = 2.35 \text{ V to } 5.25 \text{ V}$ $I_{\text{SINK}} = 200 \mu\text{A}$
Output Low Voltage, V_{OL}	0.4	0.4	V max	
Floating-State Leakage Current	± 1	± 1	$\mu\text{A max}$	
Floating-State Output Capacitance ⁶	5	5	pF max	
Output Coding	Straight (natural) binary			
CONVERSION RATE				
Conversion Time	3.2	3.2	$\mu\text{s max}$	16 SCLK cycles with SCLK at 5 MHz
Track-and-Hold Acquisition Time ³	250	250	ns max	
Throughput Rate	250	250	kSPS max	See the Serial Interface section
POWER REQUIREMENTS				
V_{DD}	2.35/5.25	2.35/5.25	V min/max	Digital I/Ps = 0 V or V_{DD} $V_{\text{DD}} = 4.75 \text{ V to } 5.25 \text{ V}$, SCLK on or off $V_{\text{DD}} = 2.35 \text{ V to } 3.6 \text{ V}$, SCLK on or off $V_{\text{DD}} = 4.75 \text{ V to } 5.25 \text{ V}$, $f_{\text{SAMPLE}} = 250 \text{ kSPS}$ $V_{\text{DD}} = 2.35 \text{ V to } 3.6 \text{ V}$, $f_{\text{SAMPLE}} = 250 \text{ kSPS}$ Typically 50 nA $V_{\text{DD}} = 5 \text{ V}$, $f_{\text{SAMPLE}} = 250 \text{ kSPS}$ $V_{\text{DD}} = 3 \text{ V}$, $f_{\text{SAMPLE}} = 250 \text{ kSPS}$ $V_{\text{DD}} = 5 \text{ V}$ $V_{\text{DD}} = 3 \text{ V}$
I_{DD}				
Normal Mode (Static)	2.5	2.5	mA typ	
	1.2	1.2	mA typ	
Normal Mode (Operational)	3	3	mA max	
	1.4	1.4	mA max	
Full Power-Down Mode	1	1	$\mu\text{A max}$	
Power Dissipation ⁷				
Normal Mode (Operational)	15	15	mW max	
	4.2	4.2	mW max	
Full Power-Down	5	5	$\mu\text{W max}$	
	3	3	$\mu\text{W max}$	

¹ Temperature range from -40°C to $+85^{\circ}\text{C}$.

² Operational from $V_{\text{DD}} = 2.0 \text{ V}$, with input low voltage (V_{INL}) 0.35 V max.

³ See the Terminology section.

⁴ B Grade, maximum specifications apply as typical figures when $V_{\text{DD}} = 4.75 \text{ V to } 5.25 \text{ V}$.

⁵ SC70 values guaranteed by characterization.

⁶ Guaranteed by characterization.

⁷ See the Power vs. Throughput Rate section.

AD7910/AD7920

TIMING SPECIFICATIONS

$V_{DD} = 2.35 \text{ V to } 5.25 \text{ V}$, $T_A = T_{MIN}$ to T_{MAX} , unless otherwise noted.

Table 3.

Parameter ¹	AD7910/AD7920 Limit at T_{MIN} , T_{MAX}	Unit	Description
f_{SCLK}^2	10 5	kHz min ³ MHz max	
$t_{CONVERT}$	$14 \times t_{SCLK}$ $16 \times t_{SCLK}$		AD7910 AD7920
t_{QUIET}	50	ns min	Minimum quiet time required between bus relinquish and start of next conversion
t_1	10	ns min	Minimum \overline{CS} pulse width
t_2	10	ns min	\overline{CS} to SCLK setup time
t_3^4	22	ns max	Delay from \overline{CS} until SDATA three-state disabled
t_4	40	ns max	Data access time after SCLK falling edge
t_5	$0.4 \times t_{SCLK}$	ns min	SCLK low pulse width
t_6	$0.4 \times t_{SCLK}$	ns min	SCLK high pulse width
$t_7^{5,6}$		ns min	SCLK to data valid hold time
	10	ns min	$V_{DD} \leq 3.3 \text{ V}$
	9.5	ns min	$3.3 \text{ V} < V_{DD} \leq 3.6 \text{ V}$
	7	ns min	$V_{DD} > 3.6 \text{ V}$
$t_8^{6,7}$	36	ns max	SCLK falling edge to SDATA three-state
	See Note 7	ns min	SCLK falling edge to SDATA three-state
$t_{POWER-UP}^8$	1	μs max	Power-up time from full power-down

¹ Guaranteed by characterization. All input signals are specified with $t_r = t_f = 5 \text{ ns}$ (10% to 90% of V_{DD}) and timed from a voltage level of 1.6 V.

² Mark/Space ratio for the SCLK input is 40/60 to 60/40.

³ Minimum f_{SCLK} at which specifications are guaranteed.

⁴ Measured with the load circuit of Figure 2 and defined as the time required for the output to cross 0.8 V or 1.8 V when $V_{DD} = 2.35 \text{ V}$ and 0.8 V or 2.0 V for $V_{DD} > 2.35 \text{ V}$.

⁵ Measured with a 50 pF load capacitor.

⁶ t_8 is derived from the measured time taken by the data outputs to change 0.5 V when loaded with the circuit of Figure 2. The measured number is then extrapolated back to remove the effects of charging or discharging the 50 pF capacitor. This means that the time, t_8 , shown in the Timing Specifications is the true bus relinquish time of the part and is independent of the bus loading.

⁷ T_7 values apply to t_8 minimum values also.

⁸ See Power-Up Time section.

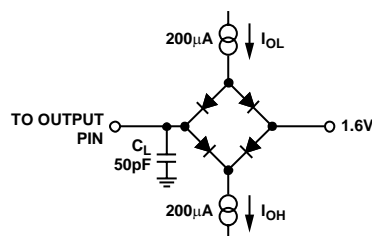

Figure 2. Load Circuit for Digital Output Timing Specifications

TIMING EXAMPLES

Figure 3 and Figure 4 show some of the timing parameters from Table 3.

TIMING EXAMPLE 1

From Figure 4, having $f_{SCLK} = 5$ MHz and a throughput rate of 250 kSPS gives a cycle time of $t_2 + 12.5(1/f_{SCLK}) + t_{ACQ} = 4 \mu s$. With $t_2 = 10$ ns min, this leaves t_{ACQ} to be $1.49 \mu s$. This $1.49 \mu s$ satisfies the requirement of 250 ns for t_{ACQ} . From Figure 4, t_{ACQ} comprises $2.5(1/f_{SCLK}) + t_8 + t_{QUIET}$, where $t_8 = 36$ ns max. This allows a value of 954 ns for t_{QUIET} , satisfying the minimum requirement of 50 ns.

TIMING EXAMPLE 2

The AD7920 can also operate with slower clock frequencies. From Figure 4, having $f_{SCLK} = 3.4$ MHz and a throughput rate of 150 kSPS gives a cycle time of $t_2 + 12.5(1/f_{SCLK}) + t_{ACQ} = 6.66 \mu s$. With $t_2 = 10$ ns min, this leaves t_{ACQ} to be $2.97 \mu s$. This $2.97 \mu s$ satisfies the requirement of 250 ns for t_{ACQ} . From Figure 4, t_{ACQ} comprises $2.5(1/f_{SCLK}) + t_8 + t_{QUIET}$, $t_8 = 36$ ns max. This allows a value of $2.19 \mu s$ for t_{QUIET} , satisfying the minimum requirement of 50 ns. As in this example and with other slower clock values, the signal may already be acquired before the conversion is complete, but it is still necessary to leave 50 ns minimum t_{QUIET} between conversions. In this example, the signal should be fully acquired at approximately Point C in Figure 4.

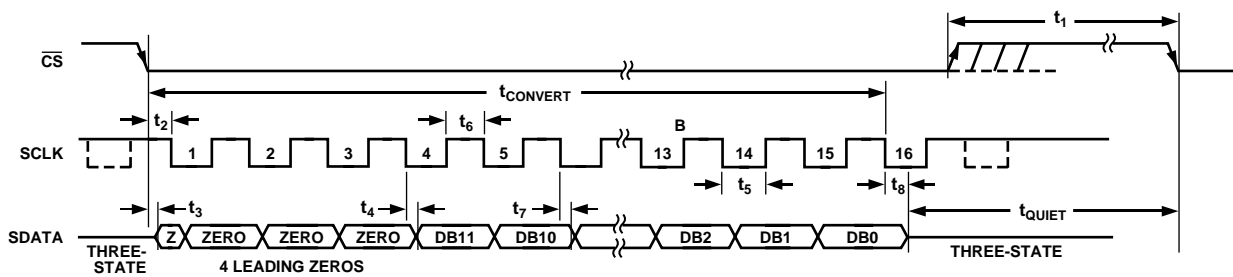

Figure 3. AD7920 Serial Interface Timing Diagram

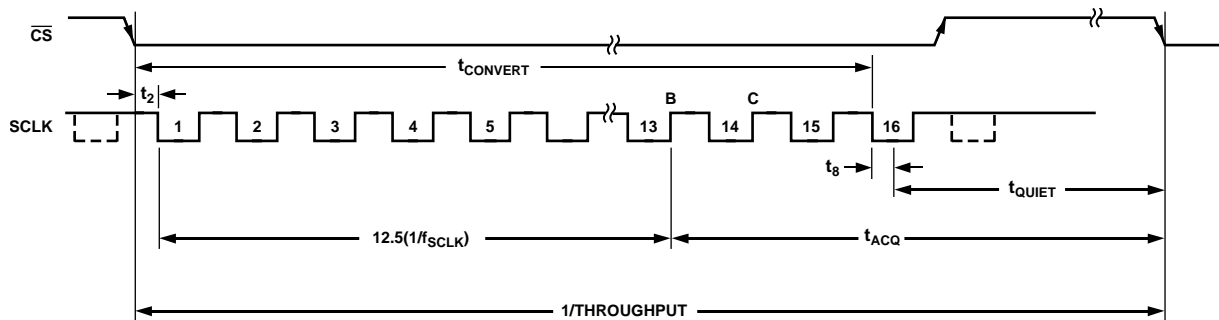

Figure 4. Serial Interface Timing Example

ABSOLUTE MAXIMUM RATINGS

T_A = 25°C, unless otherwise noted.

Table 4.

Parameter	Rating
V _{DD} to GND	−0.3 V to +7 V
Analog Input Voltage to GND	−0.3 V to V _{DD} + 0.3 V
Digital Input Voltage to GND	−0.3 V to +7 V
Digital Output Voltage to GND	−0.3 V to V _{DD} + 0.3 V
Input Current to Any Pin Except Supplies ¹	± 10 mA
Operating Temperature Range	
Commercial (A, B Grade)	−40°C to +85°C
Storage Temperature Range	−65°C to +150°C
Junction Temperature	150°C
MSOP Package	
θ _{JA} Thermal Impedance	205.9°C/W
θ _{JC} Thermal Impedance	43.74°C/W
SC70 Package	
θ _{JA} Thermal Impedance	340.2°C/W
θ _{JC} Thermal Impedance	228.9°C/W
Lead Temperature, Soldering	
Reflow (10 sec to 30 sec)	235 (0/+5)°C
ESD	3.5 kV

¹ Transient currents of up to 100 mA will not cause SCR latch-up.

Stresses above those listed under Absolute Maximum Ratings may cause permanent damage to the device. This is a stress rating only; functional operation of the device at these or any other conditions above those indicated in the operational section of this specification is not implied. Exposure to absolute maximum rating conditions for extended periods may affect device reliability.

ESD CAUTION

ESD (electrostatic discharge) sensitive device. Electrostatic charges as high as 4000 V readily accumulate on the human body and test equipment and can discharge without detection. Although this product features proprietary ESD protection circuitry, permanent damage may occur on devices subjected to high energy electrostatic discharges. Therefore, proper ESD precautions are recommended to avoid performance degradation or loss of functionality.



PIN CONFIGURATIONS AND FUNCTION DESCRIPTIONS

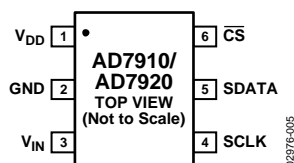

Figure 5. 6-Lead SC70 Pin Configuration

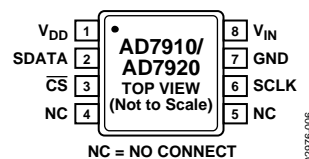

Figure 6. 8-Lead MSOP Pin Configuration

Table 5. Pin Function Descriptions

Pin No. 6-Lead SC70	Pin No. 8-Lead MSOP	Mnemonic	Description
6	3	$\overline{\text{CS}}$	Chip Select. Active low logic input. This input provides the dual function of initiating conversions on the AD7910/AD7920 and framing the serial data transfer.
1	1	V_{DD}	Power Supply Input. The V_{DD} range for the AD7910/AD7920 is from 2.35 V to 5.25 V.
2	7	GND	Analog Ground. Ground reference point for all circuitry on the AD7910/AD7920. All analog input signals should be referred to this GND voltage.
3	8	V_{IN}	Analog Input. Single-ended analog input channel. The input range is 0 to V_{DD} .
5	2	SDATA	Data Out. Logic output. The conversion result from the AD7910/AD7920 is provided on this output as a serial data stream. The bits are clocked out on the falling edge of the SCLK input. The data stream from the AD7920 consists of four leading zeros followed by the 12 bits of conversion data, which is provided MSB first. The data stream from the AD7910 consists of four leading zeros followed by the 10 bits of conversion data followed by two trailing zeros, which is also provided MSB first.
4	6	SCLK	Serial Clock. Logic input. SCLK provides the serial clock for accessing data from the part. This clock input is also used as the clock source for the AD7910/AD7920 conversion process.
N/A	4, 5	NC	No Connect.

TYPICAL PERFORMANCE CHARACTERISTICS

Figure 7 and Figure 8 show a typical FFT plot for the AD7920 and AD7910, respectively, at a 250 kSPS sampling rate and a 100 kHz input frequency.

Figure 9 shows the signal-to-(noise + distortion) ratio performance vs. input frequency for various supply voltages while sampling at 250 kSPS with an SCLK frequency of 5 MHz for the AD7920.

Figure 10 and Figure 11 show typical INL and DNL performance for the AD7920.

Figure 12 shows a graph of the total harmonic distortion vs. analog input frequency for different source impedances when using a supply voltage of 3.6 V and sampling at a rate of 250 kSPS. See the Analog Input section.

Figure 13 shows a graph of the total harmonic distortion vs. analog input signal frequency for various supply voltages while sampling at 250 kSPS with an SCLK frequency of 5 MHz.

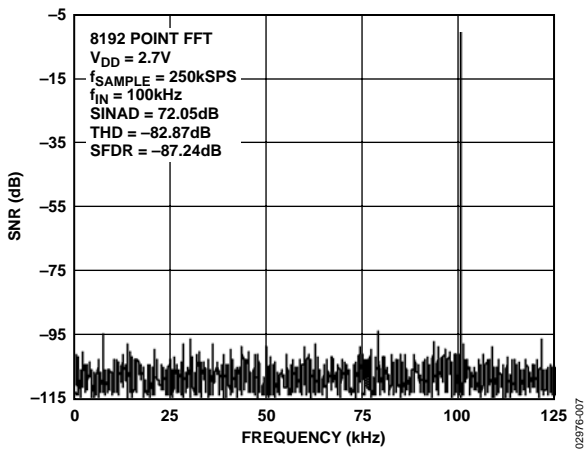

Figure 7. AD7920 Dynamic Performance at 250 kSPS

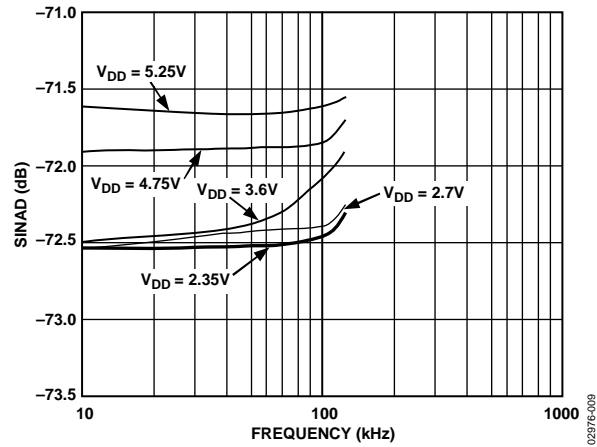

Figure 9. AD7920 SINAD vs. Input Frequency at 250 kSPS

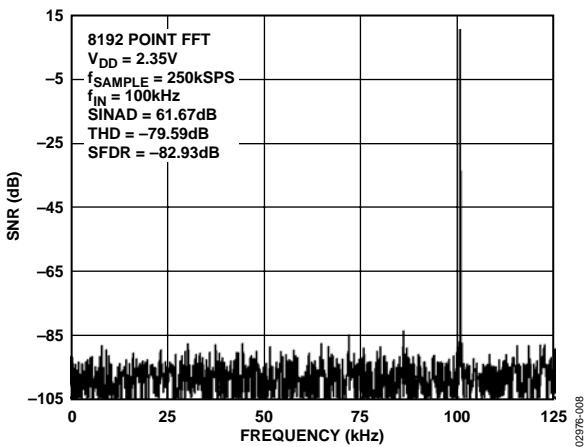

Figure 8. AD7910 Dynamic Performance at 250 kSPS

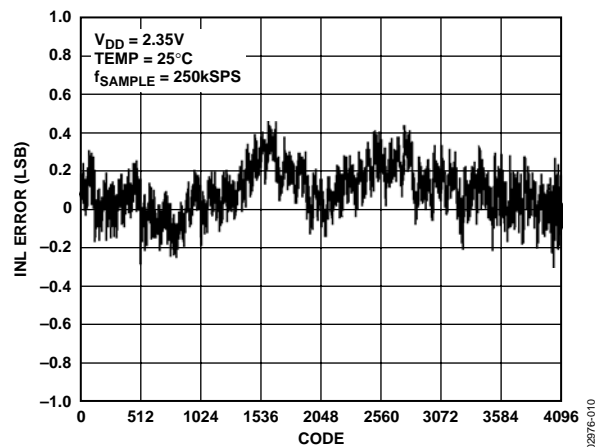

Figure 10. AD7920 INL Performance

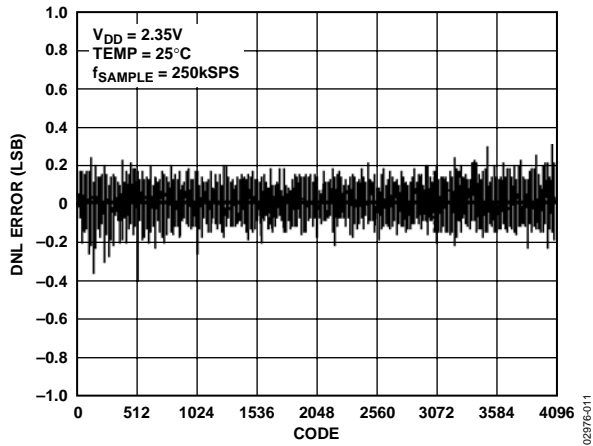

Figure 11. AD7920 DNL Performance

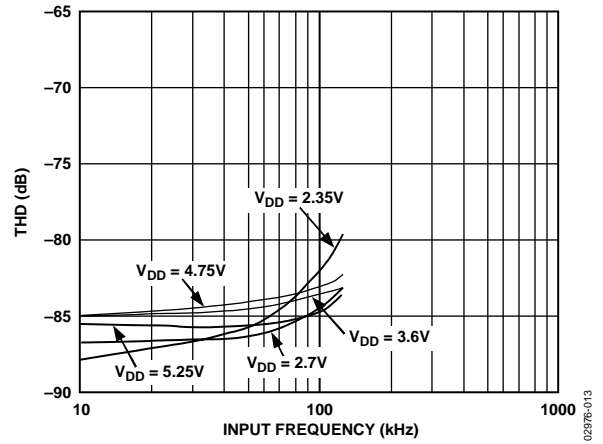

Figure 13. THD vs. Analog Input Frequency for Various Supply Voltages

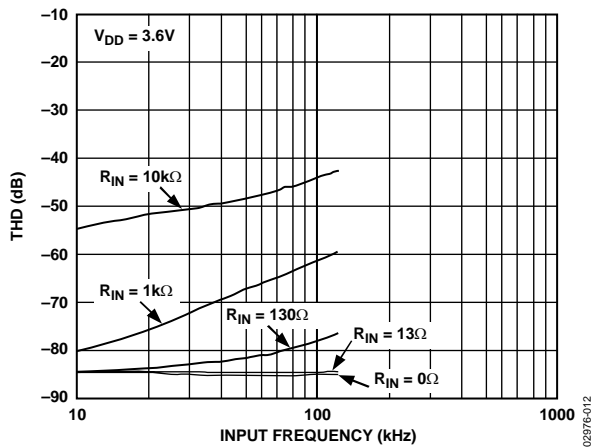

Figure 12. THD vs. Analog Input Frequency for Various Source Impedances

TERMINOLOGY

Integral Nonlinearity

The maximum deviation from a straight line passing through the endpoints of the ADC transfer function. For the AD7920 and AD7910, the endpoints of the transfer function are zero scale, a point 1 LSB below the first code transition, and full scale, a point 1 LSB above the last code transition.

Differential Nonlinearity

The difference between the measured and the ideal 1 LSB change between any two adjacent codes in the ADC.

Offset Error

The deviation of the first code transition (00 . . . 000) to (00 . . . 001) from the ideal, that is, $V_{REF} + 1$ LSB.

Gain Error

The deviation of the last code transition (111 . . . 110) to (111 . . . 111) from the ideal, that is, $V_{REF} - 1$ LSB after the offset error has been adjusted out.

Track-and-Hold Acquisition Time

The track-and-hold amplifier returns to track mode at the end of conversion. Track-and-hold acquisition time is the time required for the output of the track-and-hold amplifier to reach its final value, within ± 0.5 LSB, after the end of conversion. See the Serial Interface section for more details.

Signal-to-(Noise + Distortion) Ratio

The measured ratio of signal-to-(noise + distortion) at the output of the A/D converter. The signal is the rms amplitude of the fundamental. Noise is the sum of all nonfundamental signals up to half the sampling frequency ($f_s/2$), excluding dc. The ratio is dependent on the number of quantization levels in the digitization process. The more levels, the smaller the quantization noise. The theoretical signal-to-(noise + distortion) ratio for an ideal N-bit converter with a sine wave input is given by:

$$\text{Signal-to-(Noise + Distortion)} = (6.02N + 1.76) \text{ dB}$$

Thus, for a 12-bit converter this is 74 dB, and for a 10-bit converter this is 62 dB.

Total Unadjusted Error

A comprehensive specification that includes gain error, linearity error, and offset error.

Total Harmonic Distortion (THD)

Total harmonic distortion is the ratio of the rms sum of harmonics to the fundamental. It is defined as:

$$\text{THD (dB)} = 20 \log \frac{V_2^2 + V_3^2 + V_4^2 + V_5^2 + V_6^2}{V_1^2}$$

where:

V_1 is the rms amplitude of the fundamental.

$V_2, V_3, V_4, V_5,$ and V_6 are the rms amplitudes of the second through the sixth harmonics.

Peak Harmonic or Spurious Noise

Peak harmonic or spurious noise is the ratio of the rms value of the next largest component in the ADC output spectrum (up to $f_s/2$ and excluding dc) to the rms value of the fundamental. Normally, the value of this specification is determined by the largest harmonic in the spectrum, but for ADCs whose harmonics are buried in the noise floor, it is a noise peak.

Intermodulation Distortion

With inputs consisting of sine waves at two frequencies, f_a and f_b , any active device with nonlinearities creates distortion products at sum and difference frequencies of $m f_a \pm n f_b$ where $m, n = 0, 1, 2, 3,$ and so on. Intermodulation distortion terms are those for which neither m nor n are equal to zero. For example, the second-order terms include $(f_a + f_b)$ and $(f_a - f_b)$, while the third-order terms include $(2f_a + f_b), (2f_a - f_b), (f_a + 2f_b),$ and $(f_a - 2f_b)$.

The AD7910/AD7920 are tested using the CCIF standard, where two input frequencies are used (see f_a and f_b in the Specifications page). In this case, the second-order terms are usually distanced in frequency from the original sine waves, while the third-order terms are usually at a frequency close to the input frequencies. As a result, the second- and third-order terms are specified separately. The calculation of the intermodulation distortion is as per the THD specification, the ratio of the rms sum of the individual distortion products to the rms amplitude of the sum of the fundamentals, expressed in dB.

CIRCUIT INFORMATION

The AD7910/AD7920 are fast, micropower, 10-bit/12-bit, single-supply A/D converters, respectively. The parts can be operated from a 2.35 V to 5.25 V supply. When operated from either a 5 V supply or a 3 V supply, the AD7910/AD7920 are capable of throughput rates of 250 kSPS when provided with a 5 MHz clock.

The AD7910/AD7920 provide the user with an on-chip track-and-hold, A/D converter, and a serial interface housed in a tiny 6-lead SC70 package or 8-lead MSOP package, which offers the user considerable space saving advantages over alternative solutions.

The serial clock input accesses data from the part but also provides the clock source for the successive approximation A/D converter. The analog input range is 0 V to V_{DD} . An external reference is not required for the ADC and there is no reference on-chip. The reference for the AD7910/AD7920 is derived from the power supply and thus gives the widest dynamic input range.

The AD7910/AD7920 also feature a power-down option to allow power saving between conversions. The power-down feature is implemented across the standard serial interface, as described in the Modes of Operation section.

CONVERTER OPERATION

The AD7910/AD7920 are successive approximation analog-to-digital converters based around a charge redistribution DAC. Figure 14 and Figure 15 show simplified schematics of the ADC. Figure 14 shows the ADC during its acquisition phase. When SW2 is closed and SW1 is in Position A, the comparator is held in a balanced condition, and the sampling capacitor acquires the signal on V_{IN} .

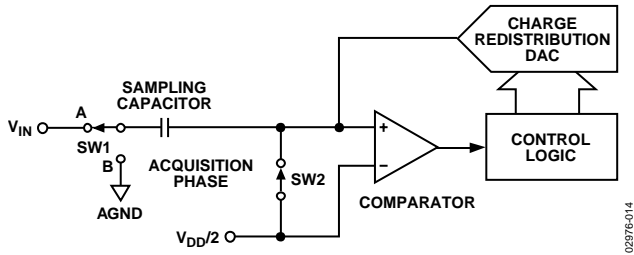

Figure 14. ADC Acquisition Phase

When the ADC starts a conversion (see Figure 15), SW2 opens and SW1 moves to Position B, causing the comparator to become unbalanced. The control logic and charge redistribution DAC are used to add and subtract fixed amounts of charge from the sampling capacitor to bring the comparator back into a balanced condition. When the comparator is rebalanced, the conversion is complete. The control logic generates the ADC output code. Figure 16 shows the ADC transfer function.

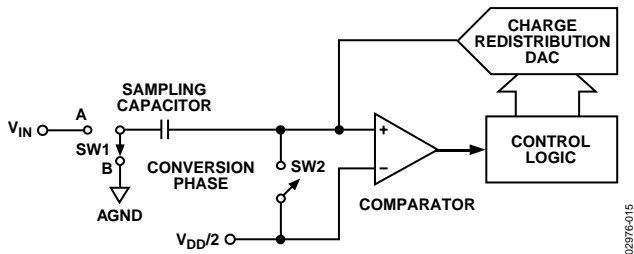

Figure 15. ADC Conversion Phase

ADC TRANSFER FUNCTION

The output coding of the AD7910/AD7920 is straight binary. The designed code transitions occur at the successive integer LSB values, that is, 1 LSB, 2 LSBs, and so on. The LSB size is $V_{DD}/4096$ for the AD7920 and $V_{DD}/1024$ for the AD7910. The ideal transfer characteristic for the AD7910/AD7920 is shown in Figure 16.

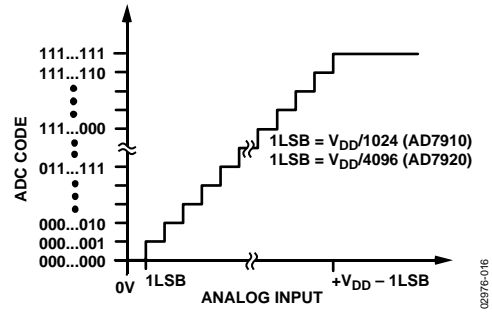

Figure 16. Transfer Characteristic

TYPICAL CONNECTION DIAGRAM

Figure 17 shows a typical connection diagram for the AD7910/AD7920. V_{REF} is taken internally from V_{DD} and, as such, V_{DD} should be well decoupled. This provides an analog input range of 0 V to V_{DD} . The conversion result is output in a 16-bit word with four leading zeros followed by the MSB of the 12-bit or 10-bit result. Two trailing zeros follow the 10-bit result from the AD7910.

Alternatively, because the supply current required by the AD7910/AD7920 is so low, a precision reference can be used as the supply source to the AD7910/AD7920. An REF19x voltage reference (REF195 for 5 V or REF193 for 3 V) can be used to supply the required voltage to the ADC (see Figure 17). This configuration is especially useful if the power supply is quite noisy or if the system supply voltages are at a value other than 5 V or 3 V (for example, 15 V). The REF19x outputs a steady voltage to the AD7910/AD7920. If the low dropout REF193 is used, the current it needs to supply to the AD7910/AD7920 is typically 1.2 mA. When the ADC is converting at a rate of 250 kSPS, the REF193 needs to supply a maximum of 1.4 mA to the AD7910/AD7920. The load regulation of the REF193 is typically 10 ppm/mA (REF193, $V_S = 5$ V), which results in an error of 14 ppm ($42 \mu\text{V}$) for the 1.4 mA drawn from it. This corresponds to a 0.057 LSB error for the AD7920 with $V_{DD} = 3$ V from the REF193 and a 0.014 LSB error for the AD7910. For applications where power consumption is of concern, the power-down mode of the ADC and the sleep mode of the REF19x reference should be used to improve power performance. See the Modes of Operation section.

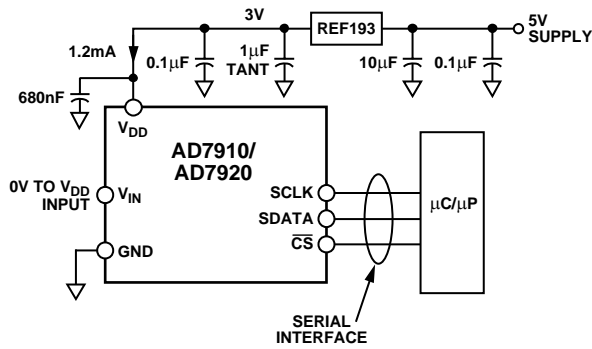

Figure 17. REF193 as Power Supply

Table 6 provides typical performance data with various references used as a V_{DD} source for a 100 kHz input tone at room temperature, under the same setup conditions.

Table 6. AD7920 Typical Performance for Various Voltage References IC

Reference Tied to V_{DD}	AD7920 SNR Performance (dB)
AD780 @ 3 V	72.65
REF193	72.35
AD780 @ 2.5 V	72.5
REF192	72.2
REF43	72.6

ANALOG INPUT

Figure 18 shows an equivalent circuit of the analog input structure of the AD7910/AD7920. The two diodes, D1 and D2, provide ESD protection for the analog input. Care must be taken to ensure that the analog input signal never exceeds the supply rails by more than 300 mV. This causes these diodes to become forward biased and start conducting current into the substrate. The maximum current these diodes can conduct without causing irreversible damage to the parties is 10 mA. Capacitor C1 in Figure 18 is typically about 6 pF and can be attributed primarily to pin capacitance. Resistor R1 is a lumped component made up of the on resistance of a switch. This resistor is typically about 100 Ω . Capacitor C2 is the ADC sampling capacitor and has a capacitance of 20 pF typically. For ac applications, removing high frequency components from the analog input signal is recommended by use of a band-pass filter on the relevant analog input pin. In applications where harmonic distortion and signal-to-noise ratio are critical, the analog input should be driven from a low impedance source. Large source impedances significantly affect the ac performance of the ADC. This can necessitate the use of an input buffer amplifier. The choice of the op amp is a function of the particular application.

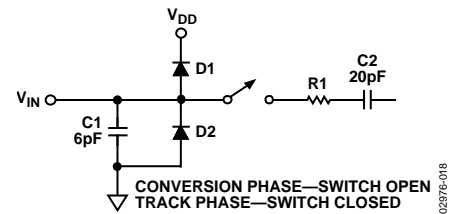

Figure 18. Equivalent Analog Input Circuit

Table 7 provides some typical performance data with various op amps used as the input buffer for a 100 kHz input tone at room temperature, under the same setup conditions.

Table 7. AD7920 Typical Performance for Various Input Buffers, $V_{DD} = 3 V$

Op Amp in the Input Buffer	AD7920 SNR Performance (dB)
AD711	72.3
AD797	72.5
AD845	71.4

When no amplifier is used to drive the analog input, the source impedance should be limited to low values. The maximum source impedance depends on the amount of total harmonic distortion (THD) that can be tolerated. The THD increases as the source impedance increases, and performance degrades (see Figure 12).

DIGITAL INPUTS

The digital inputs applied to the AD7910/AD7920 are not limited by the maximum ratings that limit the analog input. Instead, the digital inputs applied can go to 7 V and are not restricted by the $V_{DD} + 0.3 V$ limit as on the analog input. For example, if the AD7910/AD7920 were operated with a V_{DD} of 3 V, then 5 V logic levels could be used on the digital inputs. However, it is important to note that the data output on SDATA still have 3 V logic levels when $V_{DD} = 3 V$. Another advantage of SCLK and \overline{CS} not being restricted by the $V_{DD} + 0.3 V$ limit is that power supply sequencing issues are avoided. If \overline{CS} or SCLK is applied before V_{DD} , there is no risk of latch-up as there would be on the analog inputs if a signal greater than 0.3 V were applied prior to V_{DD} .

MODES OF OPERATION

The mode of operation of the AD7910/AD7920 is selected by controlling the logic state of the \overline{CS} signal during a conversion. There are two possible modes of operation, normal mode and power-down mode. The point at which \overline{CS} is pulled high after the conversion is initiated determines whether the AD7910/AD7920 enters power-down mode. Similarly, if the device is already in power-down mode, \overline{CS} can control whether it returns to normal operation or remains in power-down mode. These modes of operation are designed to provide flexible power management options. These options can be chosen to optimize the power dissipation/throughput rate ratio for different application requirements.

NORMAL MODE

This mode is intended for fastest throughput rate performance because the user does not have to worry about any power-up times; the AD7910/AD7920 remains fully powered all the time. Figure 19 shows the general diagram of the operation of the AD7910/AD7920 in this mode.

The conversion is initiated on the falling edge of \overline{CS} as described in the Serial Interface section. To ensure that the part remains fully powered up at all times, \overline{CS} must remain low until at least 10 SCLK falling edges have elapsed after the falling edge of \overline{CS} . If \overline{CS} is brought high any time after the tenth SCLK falling edge but before the end of the $t_{CONVERT}$, then the part remains powered up but the conversion is terminated and SDATA goes back into three-state.

For the AD7920, 16 serial clock cycles are required to complete the conversion and access the complete conversion result. For the AD7910, a minimum of 14 serial clock cycles is required to complete the conversion and access the complete conversion result.

\overline{CS} can idle high until the next conversion or can idle low until \overline{CS} returns high sometime prior to the next conversion, effectively idling \overline{CS} low.

Once a data transfer is complete (SDATA has returned to three-state), another conversion can be initiated after the quiet time, t_{QUIET} , has elapsed by bringing \overline{CS} low again.

POWER-DOWN MODE

This mode is intended for use in applications where slower throughput rates are required; either the ADC is powered down between conversions, or a series of conversions can be performed at a high throughput rate and the ADC is powered down for a relatively long duration between these bursts of several conversions. When the AD7910/AD7920 is in power-down mode, all analog circuitry is powered down.

To enter power-down mode, the conversion process must be interrupted by bringing \overline{CS} high anywhere after the second falling edge of SCLK, and before the tenth falling edge of SCLK, as shown in Figure 20. Once \overline{CS} is brought high in this window of SCLKs, the part enters power-down mode, the conversion that was initiated by the falling edge of \overline{CS} is terminated, and SDATA goes back into three-state. If \overline{CS} is brought high before the second SCLK falling edge, the part remains in normal mode and does not power down. This avoids accidental power-down due to glitches on the \overline{CS} line.

To exit this mode of operation and power up the AD7910/AD7920 again, a dummy conversion is performed. On the falling edge of \overline{CS} , the device begins to power up, and continues to power up as long as \overline{CS} is held low until after the falling edge of the tenth SCLK. The device is fully powered up once 16 SCLKs have elapsed and valid data results from the next conversion, as shown in Figure 21. If \overline{CS} is brought high before the tenth SCLK falling edge, the AD7910/AD7920 goes back into power-down mode again. This avoids accidental power-up due to glitches on the \overline{CS} line or an inadvertent burst of eight SCLK cycles while \overline{CS} is low. Although the device can begin to power up on the falling edge of \overline{CS} , it powers down again on the rising edge of \overline{CS} as long as it occurs before the tenth SCLK falling edge.

POWER-UP TIME

The power-up time of the AD7910/AD7920 is 1 μ s, which means that one dummy cycle is always sufficient to allow the device to power up. Once the dummy cycle is complete, the ADC fully powered up and the input signal acquired properly. The quiet time, t_{QUIET} , must still be allowed from the point where the bus goes back into three-state after the dummy conversion, to the next falling edge of \overline{CS} .

When powering up from the power-down mode with a dummy cycle, as in Figure 21, the track-and-hold that was in hold mode while the part was powered down returns to track mode after the first SCLK edge the part receives after the falling edge of \overline{CS} . This is shown as Point A in Figure 21. Although at any SCLK frequency one dummy cycle is sufficient to power up the device and acquire V_{IN} , it does not necessarily mean that a full dummy cycle of 16 SCLKs must always elapse to power up the device and fully acquire V_{IN} ; 1 μ s is sufficient to power the device up and acquire the input signal. Therefore, if a 5 MHz SCLK frequency is applied to the ADC, the cycle time is 3.2 μ s. In one dummy cycle, 3.2 μ s, the part powers up and V_{IN} is fully acquired. However, after 1 μ s with a 5 MHz SCLK, only five SCLK cycles have elapsed. At this stage, the ADC is fully powered up and the signal is acquired. In this case, the \overline{CS} can be brought high after the tenth SCLK falling edge and brought low again after a time, t_{QUIET} , to initiate the conversion.

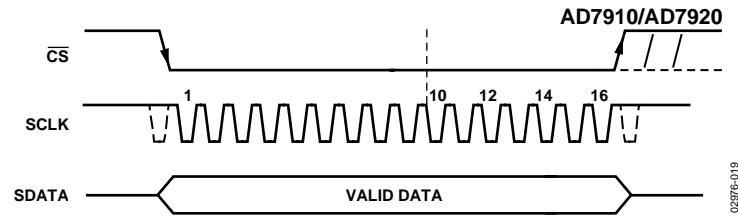

Figure 19. Normal Mode Operation

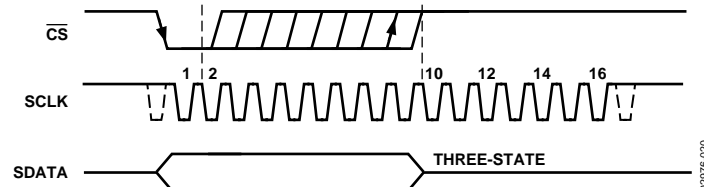

Figure 20. Entering Power-Down Mode

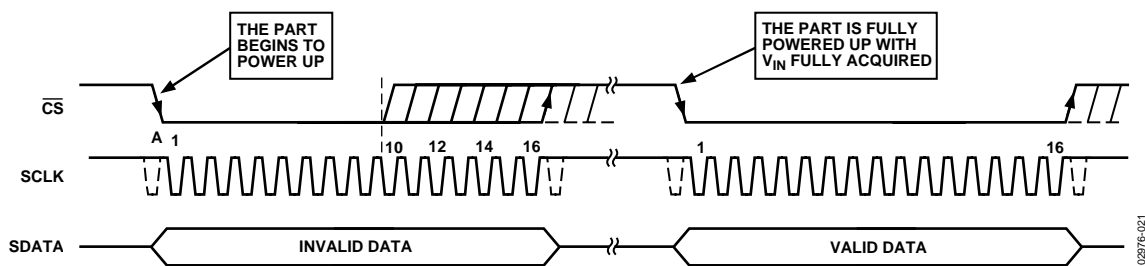

Figure 21. Exiting Power-Down Mode

When power supplies are first applied to the AD7910/AD7920, the ADC can power up in either power-down mode or in normal mode. Because of this, it is best to allow a dummy cycle to elapse to ensure the part is fully powered up before attempting a valid conversion. Likewise, if the intention is to keep the part in power-down mode while not in use and the user wishes the part to power up in power-down mode, the dummy cycle can be used to ensure the device is in power-down mode by executing a cycle such as that shown in Figure 20. Once supplies are applied to the AD7910/AD7920, the power-up time is the same as that when powering up from power-down mode. It takes approximately 1 μ s to power up fully if the part powers up in normal mode. It is not necessary to wait 1 μ s before executing a dummy cycle to ensure the desired mode of operation.

Instead, the dummy cycle can occur directly after power is supplied to the ADC. If the first valid conversion is performed directly after the dummy conversion, care must be taken to ensure that adequate acquisition time is allowed. As mentioned earlier, when powering up from the power-down mode, the part returns to track upon the first SCLK edge applied after the falling edge of CS. However, when the ADC powers up initially after supplies are applied, the track-and-hold is in track. This means, assuming the user has the facility to monitor the ADC supply current, if the ADC powers up in the desired mode of operation and thus a dummy cycle is not required to change mode then a dummy cycle is required to place the track-and-hold into track.

POWER VS. THROUGHPUT RATE

By using the power-down mode on the AD7910/AD7920 when not converting, the average power consumption of the ADC decreases at lower throughput rates. Figure 22 shows how, as the throughput rate is reduced, the device remains in its power-down state longer and the average power consumption over time drops accordingly.

For example, if the AD7910/AD7920 is operated in a continuous sampling mode with a throughput rate of 100 kSPS and an SCLK of 5 MHz ($V_{DD} = 5\text{ V}$), and the device is placed in the power-down mode between conversions, the power consumption is calculated as follows.

The power dissipation during normal mode is 15 mW ($V_{DD} = 5\text{ V}$). The power dissipation includes the power dissipated while the part is entering power-down mode, the power dissipated during the dummy conversion (when the part is exiting power-down mode and powering up), and the power dissipated during conversion.

As mentioned in the power-down mode section, to enter power-down mode, \overline{CS} has to be brought high anywhere between the second and tenth SCLK falling edge. Therefore, the power consumption when entering power-down mode varies depending on the number of SCLK cycles used. In this example, five SCLK cycles are used to enter power-down mode. This gives a time period of $5 \times (1/f_{SCLK}) = 1\text{ }\mu\text{s}$.

The power-up time is $1\text{ }\mu\text{s}$, which implies that only five SCLK cycles are required to power up the part. However, \overline{CS} has to remain low until at least the tenth SCLK falling edge when exiting power-down mode. This means that a minimum of nine SCLK cycles have to be used to exit power-down mode and power up the part.

So, if nine SCLK cycles are used, the time to power up the part and exit power-down mode is $9 \times (1/f_{SCLK}) = 1.8\text{ }\mu\text{s}$.

Finally, the conversion time is $16 \times (1/f_{SCLK}) = 3.2\text{ }\mu\text{s}$.

Therefore, the AD7910/AD7920 can be said to dissipate 15 mW for $3.2\text{ }\mu\text{s} + 1.8\text{ }\mu\text{s} + 1\text{ }\mu\text{s} = 6\text{ }\mu\text{s}$ during each conversion cycle. If the throughput rate is 100 kSPS, the cycle time is $10\text{ }\mu\text{s}$ and the average power dissipated during each cycle is $(6/10) \times (15\text{ mW}) = 9\text{ mW}$. The power dissipation when the part is in power-down has not been taken into account because the shutdown current is so low and it does not have any effect on the overall power dissipation value.

If $V_{DD} = 3\text{ V}$, SCLK = 5 MHz, and the device is again in power-down mode between conversions, the power dissipation during normal operation is 4.2 mW. Assuming the same timing conditions as before, the AD7910/AD7920 can now be said to dissipate 4.2 mW for $6\text{ }\mu\text{s}$ during each conversion cycle. With a throughput rate of 100 kSPS, the average power dissipated during each cycle is $(6/10) \times (4.2\text{ mW}) = 2.52\text{ mW}$. Figure 22 shows the power vs. throughput rate when using the power-down mode between conversions with both 5 V and 3 V supplies.

Power-down mode is intended for use with throughput rates of approximately 160 kSPS and under because at higher sampling rates there is no power saving made by using the power-down mode.

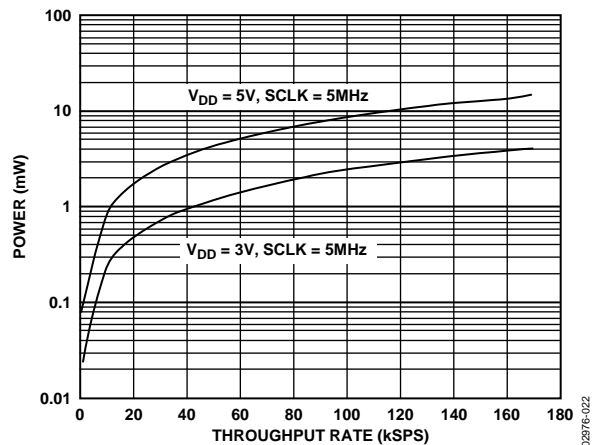

Figure 22. Power vs. Throughput Rate

SERIAL INTERFACE

Figure 23 and Figure 24 show the detailed timing diagram for serial interfacing to the AD7920 and AD7910, respectively. The serial clock provides the conversion clock and also controls the transfer of information from the AD7910/AD7920 during conversion.

The \overline{CS} signal initiates the data transfer and conversion process. The falling edge of \overline{CS} puts the track-and-hold into hold mode and takes the bus out of three-state; the analog input is sampled at that point. The conversion is also initiated at this point.

For the AD7920, the conversion requires 16 SCLK cycles to complete. Once 13 SCLK falling edges have elapsed, track-and-hold goes back into track on the next SCLK rising edge, as shown in Figure 23 at Point B. On the 16th SCLK falling edge, the SDATA line goes back into three-state. If the rising edge of \overline{CS} occurs before 16 SCLKs have elapsed then the conversion is terminated and the SDATA line goes back into three-state; otherwise, SDATA returns to three-state on the 16th SCLK falling edge, as shown in Figure 23. Sixteen serial clock cycles are required to perform the conversion process and to access data from the AD7920.

For the AD7910, the conversion requires 14 SCLK cycles to complete. Once 13 SCLK falling edges have elapsed, track-and-hold goes back into track on the next SCLK rising edge, as shown in Figure 24 at Point B.

If the rising edge of \overline{CS} occurs before 14 SCLKs have elapsed, the conversion is terminated and the SDATA line goes back into three-state. If 16 SCLKs are used in the cycle, SDATA returns to three-state on the 16th SCLK falling edge, as shown in Figure 24.

\overline{CS} going low clocks out the first leading zero to be read in by the microcontroller or DSP. The remaining data is then clocked out by subsequent SCLK falling edges beginning with the second leading zero. Thus, the first falling clock edge on the serial clock has the first leading zero provided and also clocks out the second leading zero. The final bit in the data transfer is valid on the 16th falling edge, having been clocked out on the previous (15th) falling edge.

In applications with a slower SCLK, it is possible to read in data on each SCLK rising edge. In this case, the first falling edge of SCLK clocks out the second leading zero, which could be read in the first rising edge. However, the first leading zero that was clocked out when \overline{CS} went low is missed unless it was not read in the first falling edge. The 15th falling edge of SCLK clocks out the last bit and it could be read in the 15th rising SCLK edge.

If \overline{CS} goes low just after the SCLK falling edge has elapsed, \overline{CS} clocks out the first leading zero as before, and it can be read on the SCLK rising edge. The next SCLK falling edge clocks out the second leading zero and it could be read on the following rising edge.

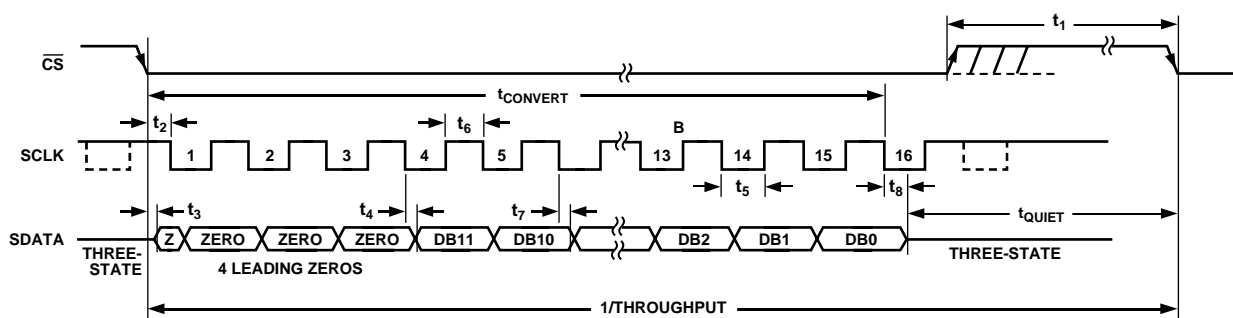

Figure 23. AD7920 Serial Interface Timing Diagram

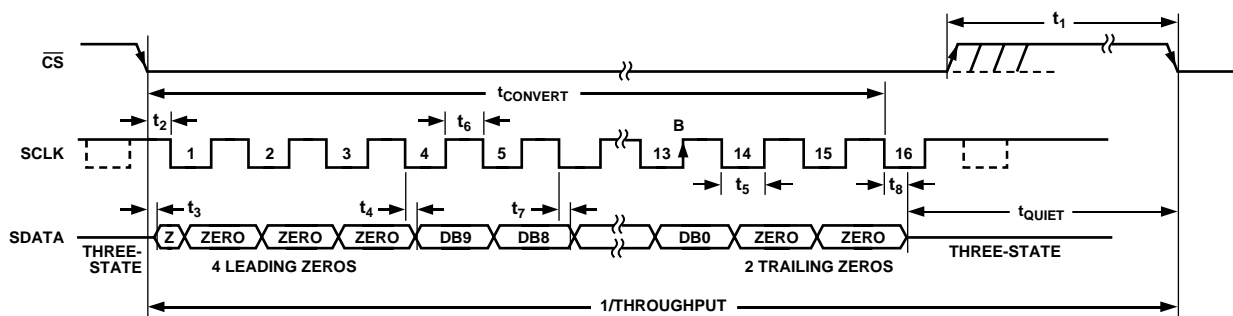

Figure 24. AD7910 Serial Interface Timing Diagram

MICROPROCESSOR INTERFACING

The serial interface on the AD7910/AD7920 allows the parts to be directly connected to a range of different microprocessors. This section explains how to interface the AD7910/AD7920 with some of the more common microcontroller and DSP serial interface protocols.

AD7910/AD7920 TO TMS320C541 INTERFACE

The serial interface on the TMS320C541 uses a continuous serial clock and frame synchronization signals to synchronize the data transfer operations with peripheral devices like the AD7910/AD7920. The CS input allows easy interfacing between the TMS320C541 and the AD7910/AD7920 without any glue logic required. The serial port of the TMS320C541 is set up to operate in burst mode (FSM = 1 in the serial port control register, SPC) with internal serial clock CLKX (MCM = 1 in SPC register) and internal frame signal (TXM = 1 in the SPC), so both pins are configured as outputs. For the AD7920, the word length should be set to 16 bits (FO = 0 in the SPC register). This DSP allows frames with a word length of 16 bits or 8 bits. Therefore, in the case of the AD7910 where just 14 bits could be required, the FO bit would be set up to 16 bits also. This means that to obtain the conversion result, 16 SCLKs are needed and two trailing zeros are clocked out in the two last clock cycles.

To summarize, the values in the SPC register are:

- FO = 0
- FSM = 1
- MCM = 1
- TXM = 1

The format bit, FO, can be set to 1 to set the word length to eight bits to implement the power-down mode on the AD7910/AD7920.

Figure 25 shows the connection diagram. It should be noted that for signal processing applications, it is imperative that the frame synchronization signal from the TMS320C541 provides equidistant sampling.

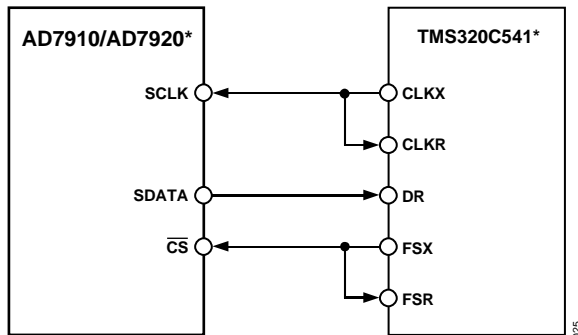

*ADDITIONAL PINS OMITTED FOR CLARITY
Figure 25. Interfacing to the TMS320C541

AD7910/AD7920 TO ADSP-218x

The ADSP-218x family of DSPs is interfaced directly to the AD7910/AD7920 without any glue logic required. The SPORT control register should be set up as follows:

- TFSW = RFSW = 1, Alternate Framing
- INVRFS = INVTFS = 1, Active Low Frame Signal
- DTYPE = 00, Right Justify Data
- ISCLK = 1, Internal Serial Clock
- TFSR = RFSR = 1, Frame Every Word
- IRFS = 0, Sets up RFS as an Input
- ITFS = 1, Sets up TFS as an Output
- SLEN = 1111, 16 Bits for the AD7920
- SLEN = 1101, 14 Bits for the AD7910

To implement power-down mode, SLEN should be set to 0111 to issue an 8-bit SCLK burst. The connection diagram is shown in Figure 26. The ADSP-218x has the TFS and RFS of the SPORT tied together, with TFS set as an output and RFS set as an input. The DSP operates in alternate framing mode and the SPORT control register is set up as described. The frame synchronization signal generated on the TFS is tied to CS and, as with all signal processing applications, equidistant sampling is necessary. However, in this example, the timer interrupt is used to control the sampling rate of the ADC and, under certain conditions, equidistant sampling can not be achieved.

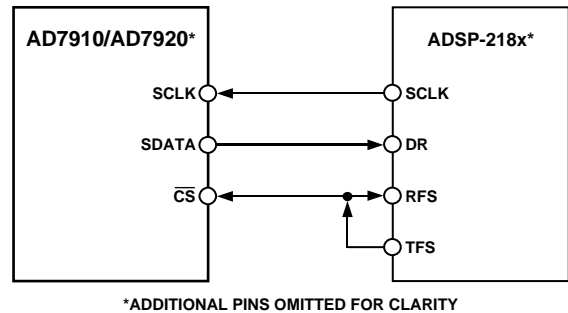

*ADDITIONAL PINS OMITTED FOR CLARITY

Figure 26. Interfacing to the ADSP-218x

The timer registers are loaded with a value that provides an interrupt at the required sample interval. When an interrupt is received, a value is transmitted with TFS/DT (ADC control word). The TFS is used to control the RFS and thus the reading of data. The frequency of the serial clock is set in the SCLKDIV register. When the instruction to transmit with TFS is given, that is, TX0 = AX0, the state of the SCLK is checked. The DSP waits until the SCLK has gone high, low, and high before transmission starts. If the timer and SCLK values are chosen such that the instruction to transmit occurs on or near the rising edge of SCLK, the data can be transmitted or it can wait until the next clock edge.

For example, the ADSP-2111 has a master clock frequency of 16 MHz. If the SCLKDIV register is loaded with the value 3, an SCLK of 2 MHz is obtained and eight master clock periods elapse for every one SCLK period. If the timer registers are loaded with the value 803, 100.5 SCLKs occur between interrupts and subsequently between transmit instructions. This situation results in nonequidistant sampling as the transmit instruction is occurring on an SCLK edge. If the number of SCLKs between interrupts is a whole integer figure of N, equidistant sampling is implemented by the DSP.

AD7910/AD7920 TO DSP563xx INTERFACE

The diagram in Figure 27 shows how the AD7910/AD7920 can be connected to the synchronous serial interface (SSI) (synchronous serial interface) of the DSP563xx family of DSPs from Motorola. The SSI is operated in synchronous and normal mode (SYN = 1 and MOD = 0 in Control Register B, CRB) with internally generated word frame sync for both Tx and Rx (Bit FSL1 = 0 and Bit FSL0 = 0 in the CRB). Set the word length in the Control Register A (CRA) to 16 by setting Bits WL2 = 0, WL1 = 1, and WL0 = 0 for the AD7920. This DSP does not offer the option for a 14-bit word length, so the AD7910 word length is set to 16 bits like the AD7920. For the AD7910, the conversion process uses 16 SCLK cycles, with the last two clock periods clocking out two trailing zeros to fill the 16-bit word.

To implement the power-down mode on the AD7910/AD7920, the word length can be changed to eight bits by setting Bits WL2 = 0, WL1 = 0, and WL0 = 0 in CRA. The FSP bit in the CRB register can be set to 1, which means the frame goes low and a conversion starts. Likewise, by means of Bits SCD2, SCKD, and SHFD in the CRB register, it is established that Pin SC2 (the frame sync signal) and SCK in the serial port is configured as outputs and the MSB is shifted first.

To summarize:

MOD = 0
 SYN = 1
 WL2, WL1, WL0 Depend on the Word Length
 FSL1 = 0, FSL0 = 0
 FSP = 1, Negative Frame Sync
 SCD2 = 1
 SCKD = 1
 SHFD = 0

It should be noted that for signal processing applications, it is imperative that the frame synchronization signal from the DSP563xx provides equidistant sampling.

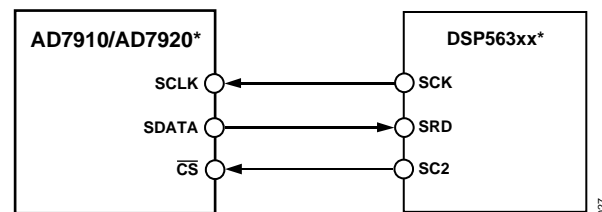

*ADDITIONAL PINS OMITTED FOR CLARITY

Figure 27. Interfacing to the DSP563xx

02876-027

APPLICATION HINTS

GROUNDING AND LAYOUT

The printed circuit board that houses the AD7910/AD7920 should be designed such that the analog and digital sections are separated and confined to certain areas of the board. This facilitates the use of ground planes that can be easily separated. A minimum etch technique is generally best for ground planes as it gives the best shielding. Digital and analog ground planes should be joined at only one place. If the AD7910/AD7920 is in a system where multiple devices require an AGND to DGND connection then the connection should still be made at one point only, a star ground point that should be established as close to the AD7910/AD7920 as possible.

Avoid running digital lines under the device as these couple noise onto the die. The analog ground plane should be allowed to run under the AD7910/AD7920 to avoid noise coupling. The power supply lines to the AD7910/AD7920 should use as large a trace as possible to provide low impedance paths and reduce the effects of glitches on the power supply line. Fast switching signals like clocks should be shielded with digital ground to avoid radiating noise to other sections of the board, and clock signals should never be run near the analog inputs. Avoid crossover of digital and analog signals. Traces on opposite sides of the board should run at right angles to each other. This reduces the effects of feedthrough through the board. A micro-strip technique is by far the best but is not always possible with a double-sided board. In this technique, the component side of the board is dedicated to ground planes while signals are placed on the solder side.

Good decoupling is also very important. The supply should be decoupled with, for example, a 680 nF 0805 to GND. When using the SC70 package in applications where the size of the components is of concern, a 220 nF 0603 capacitor, for example, could be used instead. However, in that case, the decoupling can not be as effective and can result in an approximate SINAD degradation of 0.3 dB. To achieve the best performance from these decoupling components, the user should endeavor to keep the distance between the decoupling capacitor and the V_{DD} and GND pins to a minimum with short track lengths connecting the respective pins. Figure 28 and Figure 29 show the recommended positions of the decoupling capacitor for the MSOP and SC70 packages, respectively.

As can be seen in Figure 28, for the MSOP package, the decoupling capacitor is placed as close as possible to the IC, with short track lengths to V_{DD} and GND pins. The decoupling capacitor could also be placed on the underside of the PCB directly underneath the IC, between the V_{DD} and GND pins attached by vias. This method would not be recommended on PCBs above a standard 1.6 mm thickness. The best performance is seen with the decoupling capacitor on the top of the PCB next to the IC.

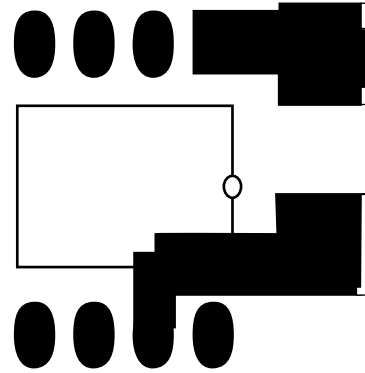

Figure 28. Recommended Supply Decoupling Scheme for the AD7910/AD7920 MSOP Package

Similarly, for the SC70 package, the decoupling capacitor should be located as close as possible to the V_{DD} and GND pins. Because of its pinout, that is, V_{DD} being next to GND, the decoupling capacitor can be placed extremely close to the IC. The decoupling capacitor could be placed on the underside of the PCB directly under the V_{DD} and GND pins, but, as before, the best performance is seen with the decoupling capacitor on the same side as the IC.

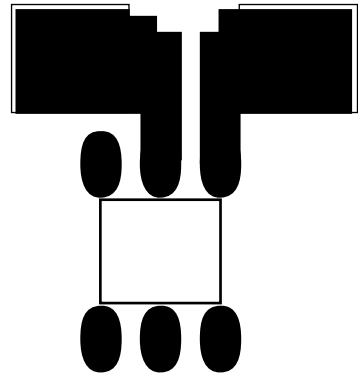

Figure 29. Recommended Supply Decoupling Scheme for the AD7910/AD7920 SC70 Package

EVALUATING PERFORMANCE

The evaluation board package includes a fully assembled and tested evaluation board, documentation, and software for controlling the board from the PC via the Eval-Board Controller. To demonstrate/evaluate the ac and dc performance of the AD7910/AD7920, the evaluation board controller can be used in conjunction with the AD7910/AD7920CB evaluation boards as well as many other Analog Devices' evaluation boards ending in the CB designator.

The software allows the user to perform ac (fast Fourier transform) and dc (histogram of codes) tests on the AD7910/AD7920. See the evaluation board technical note for more information.

OUTLINE DIMENSIONS

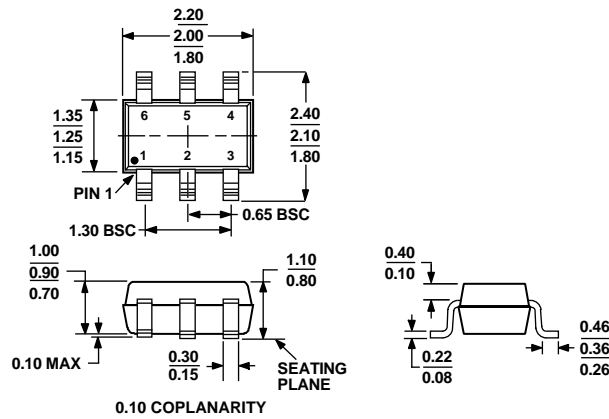

COMPLIANT TO JEDEC STANDARDS MO-203-AB

Figure 30. 6-Lead Thin Shrink Small Outline Transistor Package [SC70] (KS-6)
Dimensions shown in millimeters

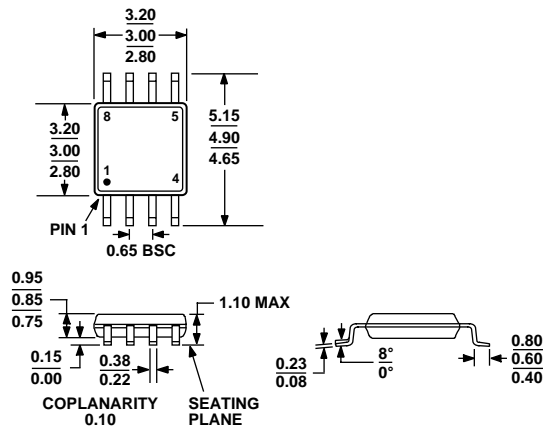

COMPLIANT TO JEDEC STANDARDS MO-187-AA

Figure 31. 8-Lead Mini Small Outline Package [MSOP] (RM-8)
Dimensions shown in millimeters

AD7910/AD7920

ORDERING GUIDE

Model	Temperature Range	Linearity Error (LSB) ¹	Package Description	Package Option	Branding
AD7910AKS-500RL7	-40°C to +85°C	±0.5 max	6-Lead SC70	KS-6	CVA
AD7910AKS-REEL	-40°C to +85°C	±0.5 max	6-Lead SC70	KS-6	CVA
AD7910AKS-REEL7	-40°C to +85°C	±0.5 max	6-Lead SC70	KS-6	CVA
AD7910AKSZ-500RL7 ²	-40°C to +85°C	±0.5 max	6-Lead SC70	KS-6	C49
AD7910AKSZ-REEL ²	-40°C to +85°C	±0.5 max	6-Lead SC70	KS-6	C49
AD7910AKSZ-REEL7 ²	-40°C to +85°C	±0.5 max	6-Lead SC70	KS-6	C49
AD7910ARM	-40°C to +85°C	±0.5 max	8-Lead MSOP	RM-8	CVA
AD7910ARM-REEL	-40°C to +85°C	±0.5 max	8-Lead MSOP	RM-8	CVA
AD7910ARM-REEL7	-40°C to +85°C	±0.5 max	8-Lead MSOP	RM-8	CVA
AD7910ARMZ ²	-40°C to +85°C	±0.5 max	8-Lead MSOP	RM-8	C49
AD7920AKS-500RL7	-40°C to +85°C	±0.75 typ	6-Lead SC70	KS-6	CUA
AD7920AKS-REEL	-40°C to +85°C	±0.75 typ	6-Lead SC70	KS-6	CUA
AD7920AKS-REEL7	-40°C to +85°C	±0.75 typ	6-Lead SC70	KS-6	CUA
AD7920AKSZ-500RL7 ²	-40°C to +85°C	±0.75 typ	6-Lead SC70	KS-6	C47
AD7920AKSZ-REEL7 ²	-40°C to +85°C	±0.75 typ	6-Lead SC70	KS-6	C47
AD7920BKS-500RL7	-40°C to +85°C	±1.5 max	6-Lead SC70	KS-6	CUB
AD7920BKS-REEL	-40°C to +85°C	±1.5 max	6-Lead SC70	KS-6	CUB
AD7920BKS-REEL7	-40°C to +85°C	±1.5 max	6-Lead SC70	KS-6	CUB
AD7920BKSZ-500RL7 ²	-40°C to +85°C	±1.5 max	6-Lead SC70	KS-6	C4B
AD7920BKSZ-REEL ²	-40°C to +85°C	±1.5 max	6-Lead SC70	KS-6	C4B
AD7920BKSZ-REEL7 ²	-40°C to +85°C	±1.5 max	6-Lead SC70	KS-6	C4B
AD7920BRM	-40°C to +85°C	±1.5 max	8-Lead MSOP	RM-8	CUB
AD7920BRM-REEL	-40°C to +85°C	±1.5 max	8-Lead MSOP	RM-8	CUB
AD7920BRM-REEL7	-40°C to +85°C	±1.5 max	8-Lead MSOP	RM-8	CUB
AD7920BRMZ ²	-40°C to +85°C	±1.5 max	8-Lead MSOP	RM-8	C4B
AD7920BRMZ-REEL ²	-40°C to +85°C	±1.5 max	8-Lead MSOP	RM-8	C4B
AD7920BRMZ-REEL7 ²	-40°C to +85°C	±1.5 max	8-Lead MSOP	RM-8	C4B
EVAL-AD7910CB ³				Evaluation Board	
EVAL-AD7920CB ³				Evaluation Board	
EVAL-CONTROL BRD2 ⁴				Controller Board	

¹ Linearity error refers to integral nonlinearity.

² Z = Pb-free part.

³ This can be used as a standalone evaluation board or in conjunction with the EVAL-CONTROL BRD2 for evaluation/demonstration purposes.

⁴ This board is a complete unit that allows a PC to control and communicate with all Analog Devices evaluation boards ending in the CB designator. To order a complete evaluation kit, a particular ADC evaluation board must be ordered, for example, EVAL-AD7920CB, the EVAL-CONTROL BRD2, and a 12 V ac transformer. See relevant evaluation board technical note for more information.

Looking for pricing, stock, or lifecycle information?

Click below to explore more details on WIN SOURCE:

 [View AD7910ARMZ on WIN SOURCE](#)

 [Analog Devices Inc. Information](#)

Optimize Your Supply Chain with WIN SOURCE Solutions

-  Global Sourcing Solution
-  Obsolete Management
-  Cost Control Management
-  Shortage Management
-  Alternative Solution
-  Excess Inventory Management