



**THE DATASHEET OF  
SN74CBT16800CDGVR**



# SN74CBT16800C

## 20-BIT FET BUS SWITCH WITH PRECHARGED OUTPUTS 5-V BUS SWITCH WITH $-2$ -V UNDERSHOOT PROTECTION

SCDS117C – JANUARY 2003 – REVISED OCTOBER 2003

- Member of the Texas Instruments Widebus™ Family
- Undershoot Protection for Off-Isolation on A and B Ports Up To  $-2$  V
- B-Port Outputs Are Precharged by Bias Voltage (BIASV) to Minimize Signal Distortion During Live Insertion and Hot-Plugging
- Supports PCI Hot Plug
- Bidirectional Data Flow, With Near-Zero Propagation Delay
- Low ON-State Resistance ( $r_{on}$ ) Characteristics ( $r_{on} = 3 \Omega$  Typical)
- Low Input/Output Capacitance Minimizes Loading and Signal Distortion ( $C_{iO(OFF)} = 5.5$  pF Typical)
- Data and Control Inputs Provide Undershoot Clamp Diodes
- Low Power Consumption ( $I_{CC} = 3 \mu A$  Max)
- $V_{CC}$  Operating Range From 4 V to 5.5 V
- Data I/Os Support 0 to 5-V Signaling Levels (0.8-V, 1.2-V, 1.5-V, 1.8-V, 2.5-V, 3.3-V, 5-V)
- Control Inputs Can Be Driven by TTL or 5-V/3.3-V CMOS Outputs
- $I_{off}$  Supports Partial-Power-Down Mode Operation
- Latch-Up Performance Exceeds 100 mA Per JESD 78, Class II
- ESD Performance Tested Per JESD 22
  - 2000-V Human-Body Model (A114-B, Class II)
  - 1000-V Charged-Device Model (C101)
- Supports Both Digital and Analog Applications: PCI Interface, Memory Interleaving, Bus Isolation, Low-Distortion Signal Gating

DGG, DGV, OR DL PACKAGE  
(TOP VIEW)

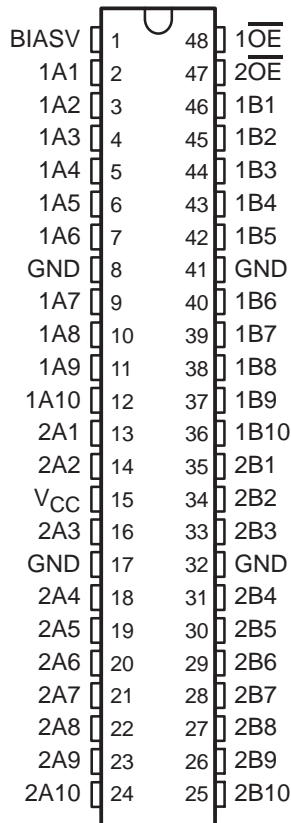

### description/ordering information

The SN74CBT16800C is a high-speed TTL-compatible FET bus switch with low ON-state resistance ( $r_{on}$ ), allowing for minimal propagation delay. Active Undershoot-Protection Circuitry on the A and B ports of the SN74CBT16800C provides protection for undershoot up to  $-2$  V by sensing an undershoot event and ensuring that the switch remains in the proper OFF state. The device also precharges the B port to a user-selectable bias voltage (BIASV) to minimize live-insertion noise.



Please be aware that an important notice concerning availability, standard warranty, and use in critical applications of Texas Instruments semiconductor products and disclaimers thereto appears at the end of this data sheet.

Widebus is a trademark of Texas Instruments.

PRODUCTION DATA information is current as of publication date. Products conform to specifications per the terms of Texas Instruments standard warranty. Production processing does not necessarily include testing of all parameters.



POST OFFICE BOX 655303 • DALLAS, TEXAS 75265

Copyright © 2003, Texas Instruments Incorporated

**SN74CBT16800C**  
**20-BIT FET BUS SWITCH WITH PRECHARGED OUTPUTS**  
**5-V BUS SWITCH WITH -2-V UNDERSHOOT PROTECTION**

SCDS117C – JANUARY 2003 – REVISED OCTOBER 2003

**description/ordering information (continued)**

The SN74CBT16800C is organized as two 10-bit bus switches with separate output-enable ( $\overline{1OE}$ ,  $\overline{2OE}$ ) inputs. It can be used as two 10-bit bus switches or as one 20-bit bus switch. When  $\overline{OE}$  is low, the associated 10-bit bus switch is ON, and the A port is connected to the B port, allowing bidirectional data flow between ports. When  $\overline{OE}$  is high, the associated 10-bit bus switch is OFF, and a high-impedance state exists between the A and B ports. The B port is precharged to BIASV through the equivalent of a 10-k $\Omega$  resistor when  $\overline{OE}$  is high, or if the device is powered down ( $V_{CC} = 0$  V).

During insertion (or removal) of a card into (or from) an active bus, the card's output voltage may be close to GND. When the connector pins make contact, the card's parasitic capacitance tries to force the bus signal to GND, creating a possible glitch on the active bus. This glitching effect can be reduced by using a bus switch with precharged bias voltage (BIASV) of the bus switch equal to the input threshold voltage level of the receivers on the active bus. This method will ensure that any glitch produced by insertion (or removal) of the card will not cross the input threshold region of the receivers on the active bus, minimizing the effects of live-insertion noise.

This device is fully specified for partial-power-down applications using  $I_{off}$ . The  $I_{off}$  feature ensures that damaging current will not backflow through the device when it is powered down. The device has isolation during power off.

To ensure the high-impedance state during power up or power down,  $\overline{OE}$  should be tied to  $V_{CC}$  through a pullup resistor; the minimum value of the resistor is determined by the current-sinking capability of the driver.

**ORDERING INFORMATION**

TA	PACKAGE†		ORDERABLE PART NUMBER	TOP-SIDE MARKING
-40°C to 85°C	SSOP – DL	Tube	SN74CBT16800CDL	CBT16800C
		Tape and reel	SN74CBT16800CDLR	
	TSSOP – DGG	Tube	SN74CBT16800CDGG	CBT16800C
		Tape and reel	SN74CBT16800CDGGR	
	TVSOP – DGV	Tape and reel	SN74CBT16800CDGVR	CY800C

† Package drawings, standard packing quantities, thermal data, symbolization, and PCB design guidelines are available at [www.ti.com/sc/package](http://www.ti.com/sc/package).

**FUNCTION TABLE**  
**(each 10-bit bus switch)**

INPUT $\overline{OE}$	INPUT/OUTPUT A	FUNCTION
L	B	A port = B port
H	Z	Disconnect B port = BIASV



**SN74CBT16800C**  
**20-BIT FET BUS SWITCH WITH PRECHARGED OUTPUTS**  
**5-V BUS SWITCH WITH -2-V UNDERSHOOT PROTECTION**

SCDS117C – JANUARY 2003 – REVISED OCTOBER 2003

logic diagram (positive logic)

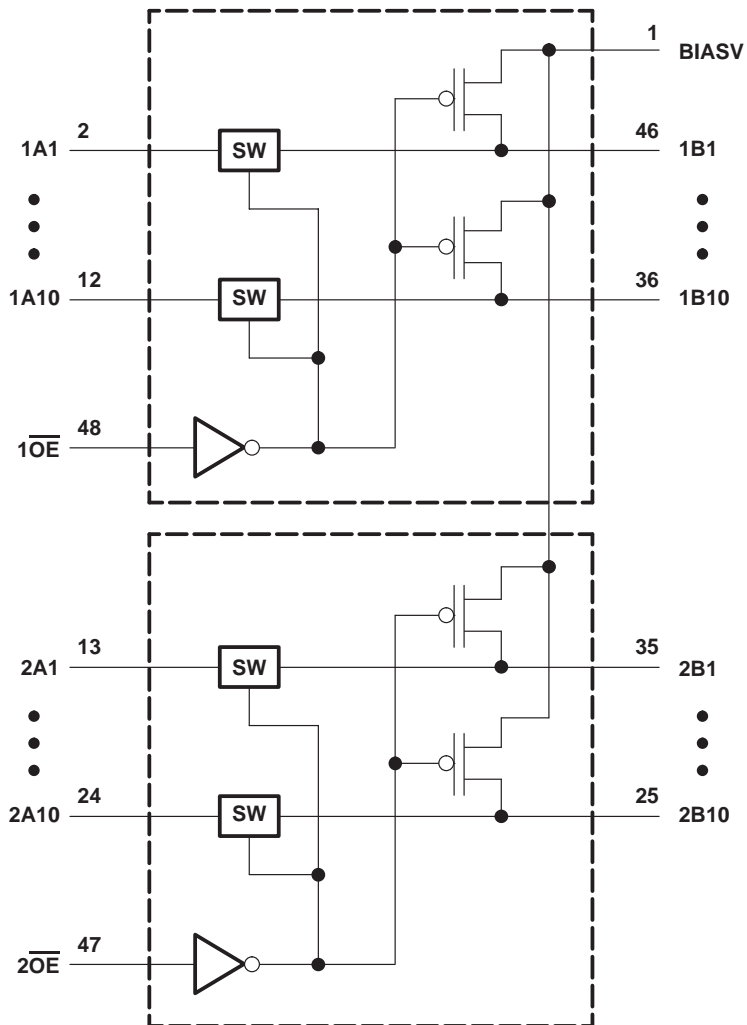

simplified schematic, each FET switch (SW)

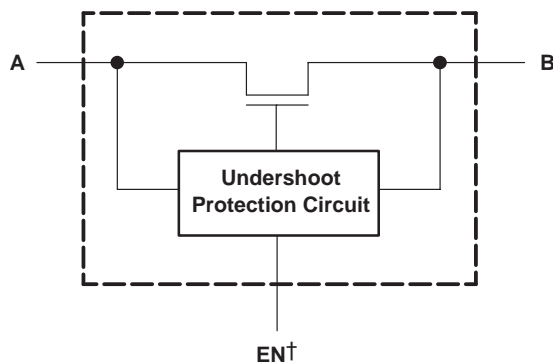

† EN is the internal enable signal applied to the switch.

**SN74CBT16800C**  
**20-BIT FET BUS SWITCH WITH PRECHARGED OUTPUTS**  
**5-V BUS SWITCH WITH -2-V UNDERSHOOT PROTECTION**

SCDS117C – JANUARY 2003 – REVISED OCTOBER 2003

**absolute maximum ratings over operating free-air temperature range (unless otherwise noted)†**

Supply voltage range, $V_{CC}$	-0.5 V to 7 V
Bias supply voltage range, BIASV	-0.5 V to 7 V
Control input voltage range, $V_{IN}$ (see Notes 1 and 2)	-0.5 V to 7 V
Switch I/O voltage range, $V_{I/O}$ (see Notes 1, 2, and 3)	-0.5 V to 7 V
Control input clamp current, $I_{IK}$ ( $V_{IN} < 0$ )	-50 mA
I/O port clamp current, $I_{I/OK}$ ( $V_{I/O} < 0$ )	-50 mA
ON-state switch current, $I_{I/O}$ (see Note 4)	$\pm 128$ mA
Continuous current through $V_{CC}$ or GND terminals	$\pm 100$ mA
Package thermal impedance, $\theta_{JA}$ (see Note 5): DGG package	70°C/W
DGV package	58°C/W
DL package	63°C/W
Storage temperature range, $T_{stg}$	-65°C to 150°C

† Stresses beyond those listed under “absolute maximum ratings” may cause permanent damage to the device. These are stress ratings only, and functional operation of the device at these or any other conditions beyond those indicated under “recommended operating conditions” is not implied. Exposure to absolute-maximum-rated conditions for extended periods may affect device reliability.

- NOTES:
1. All voltages are with respect to ground unless otherwise specified.
  2. The input and output voltage ratings may be exceeded if the input and output clamp-current ratings are observed.
  3.  $V_I$  and  $V_O$  are used to denote specific conditions for  $V_{I/O}$ .
  4.  $I_I$  and  $I_O$  are used to denote specific conditions for  $I_{I/O}$ .
  5. The package thermal impedance is calculated in accordance with JESD 51-7.

**recommended operating conditions (see Note 6)**

	MIN	MAX	UNIT
$V_{CC}$ Supply voltage	4	5.5	V
BIASV Bias supply voltage	0	$V_{CC}$	V
$V_{IH}$ High-level control input voltage	2	5.5	V
$V_{IL}$ Low-level control input voltage	0	0.8	V
$V_{I/O}$ Data input/output voltage	0	5.5	V
$T_A$ Operating free-air temperature	-40	85	°C

NOTE 6: All unused control inputs of the device must be held at  $V_{CC}$  or GND to ensure proper device operation. Refer to the TI application report, *Implications of Slow or Floating CMOS Inputs*, literature number SCBA004. BIASV is a supply voltage, not a control input.



**SN74CBT16800C**  
**20-BIT FET BUS SWITCH WITH PRECHARGED OUTPUTS**  
**5-V BUS SWITCH WITH -2-V UNDERSHOOT PROTECTION**

SCDS117C – JANUARY 2003 – REVISED OCTOBER 2003

**electrical characteristics over recommended operating free-air temperature range (unless otherwise noted)**

PARAMETER		TEST CONDITIONS		MIN	TYP†	MAX	UNIT	
V <sub>IK</sub>	Control inputs	V <sub>CC</sub> = 4.5 V,	I <sub>IN</sub> = -18 mA			-1.8	V	
V <sub>IKU</sub>	Data inputs	V <sub>CC</sub> = 5 V,	0 mA > I <sub>I</sub> ≥ -50 mA, V <sub>IN</sub> = V <sub>CC</sub> or GND, Switch OFF			-2	V	
V <sub>O(USP)‡</sub>		V <sub>CC</sub> = BIASV = 5 V,	I <sub>I</sub> = -10 mA, V <sub>IN</sub> = V <sub>CC</sub> or GND, Switch OFF		3		V	
V <sub>O</sub>	B port	V <sub>CC</sub> = 0 V,	BIASV = V <sub>X</sub> , I <sub>O</sub> = 0	V <sub>X</sub> -0.1		V <sub>X</sub>	V	
I <sub>IN</sub>	Control inputs	V <sub>CC</sub> = 5.5 V,	V <sub>IN</sub> = V <sub>CC</sub> or GND			±1	μA	
I <sub>O</sub>	B port	V <sub>CC</sub> = 4.5 V,	BIASV = 2.4 V, V <sub>O</sub> = 0, Switch OFF, V <sub>IN</sub> = V <sub>CC</sub> or GND		0.25		mA	
I <sub>OZ</sub> §		V <sub>CC</sub> = 5.5 V,	V <sub>O</sub> = 0 to 5.5 V, V <sub>I</sub> = 0, Switch OFF, V <sub>IN</sub> = V <sub>CC</sub> or GND			±10	μA	
I <sub>off</sub>		V <sub>CC</sub> = 0,	V <sub>O</sub> = 0 to 5.5 V, V <sub>I</sub> = 0			10	μA	
I <sub>CC</sub>		V <sub>CC</sub> = 5.5 V,	I <sub>I/O</sub> = 0, V <sub>IN</sub> = V <sub>CC</sub> or GND, Switch ON or OFF			3	μA	
ΔI <sub>CC</sub> ¶	Control inputs	V <sub>CC</sub> = 5.5 V,	One input at 3.4 V, Other inputs at V <sub>CC</sub> or GND			2.5	mA	
C <sub>in</sub>	Control inputs	V <sub>IN</sub> = 3 V or 0			4.5		pF	
C <sub>iO(OFF)</sub>	A port	V <sub>I/O</sub> = 3 V or 0,	Switch OFF, V <sub>IN</sub> = V <sub>CC</sub> or GND		5.5		pF	
C <sub>iO(ON)</sub>		V <sub>I/O</sub> = 3 V or 0,	Switch ON, V <sub>IN</sub> = V <sub>CC</sub> or GND		15.5		pF	
r <sub>on</sub> #		V <sub>CC</sub> = 4 V, TYP at V <sub>CC</sub> = 4 V	V <sub>I</sub> = 2.4 V, I <sub>O</sub> = -15 mA		8	12	Ω	
		V <sub>CC</sub> = 4.5 V	V <sub>I</sub> = 0	I <sub>O</sub> = 64 mA		3		6
				I <sub>O</sub> = 30 mA		3		6
			V <sub>I</sub> = 2.4 V, I <sub>O</sub> = -15 mA		5	10		

V<sub>IN</sub> and I<sub>IN</sub> refer to control inputs. V<sub>I</sub>, V<sub>O</sub>, I<sub>I</sub>, and I<sub>O</sub> refer to data pins.

† All typical values are at V<sub>CC</sub> = 5 V (unless otherwise noted), T<sub>A</sub> = 25°C.

‡ V<sub>O(USP)</sub> = A-port undershoot static protection.

§ For I/O ports, the parameter I<sub>OZ</sub> includes the input leakage current.

¶ This is the increase in supply current for each input that is at the specified voltage level, rather than V<sub>CC</sub> or GND.

# Measured by the voltage drop between the A and B terminals at the indicated current through the switch. ON-state resistance is determined by the lower of the voltages of the two (A or B) terminals.

**switching characteristics over recommended operating free-air temperature range (unless otherwise noted) (see Figure 1)**

PARAMETER	TEST CONDITIONS	FROM (INPUT)	TO (OUTPUT)	V <sub>CC</sub> = 4 V		V <sub>CC</sub> = 5 V ± 0.5 V		UNIT
				MIN	MAX	MIN	MAX	
t <sub>pd</sub>		A or B	B or A		0.24		0.15	ns
t <sub>PZH</sub>	BIASV = GND	$\overline{\text{OE}}$	A or B		6.5	1.5	6	ns
t <sub>PZL</sub>	BIASV = 3 V				6.5	1.5	6	
t <sub>PHZ</sub>	BIASV = GND	$\overline{\text{OE}}$	A or B		6.5	1.5	6	ns
t <sub>PLZ</sub>	BIASV = 3 V				6.5	1.5	6	

|| The propagation delay is the calculated RC time constant of the typical ON-state resistance of the switch and the specified load capacitance, when driven by an ideal voltage source (zero output impedance).



**SN74CBT16800C**  
**20-BIT FET BUS SWITCH WITH PRECHARGED OUTPUTS**  
**5-V BUS SWITCH WITH -2-V UNDERSHOOT PROTECTION**

SCDS117C – JANUARY 2003 – REVISED OCTOBER 2003

**PARAMETER MEASUREMENT INFORMATION**

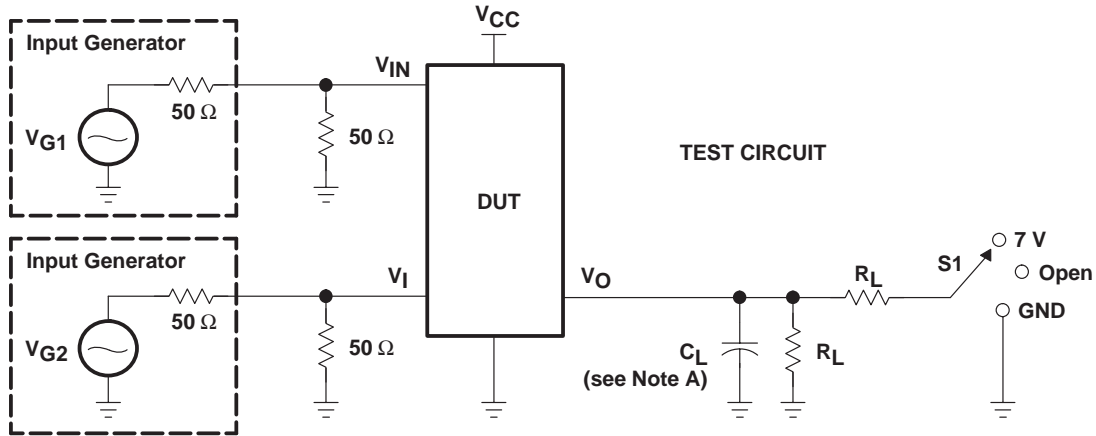

TEST	V <sub>CC</sub>	S1	R <sub>L</sub>	V <sub>I</sub>	C <sub>L</sub>	V <sub>Δ</sub>
t <sub>pd</sub> (s)	5 V ± 0.5 V	Open	500 Ω	V <sub>CC</sub> or GND	50 pF	
	4 V	Open	500 Ω	V <sub>CC</sub> or GND	50 pF	
t <sub>PLZ</sub> /t <sub>PZL</sub>	5 V ± 0.5 V	7 V	500 Ω	GND	50 pF	0.3 V
	4 V	7 V	500 Ω	GND	50 pF	0.3 V
t <sub>PHZ</sub> /t <sub>PZH</sub>	5 V ± 0.5 V	Open	500 Ω	V <sub>CC</sub>	50 pF	0.3 V
	4 V	Open	500 Ω	V <sub>CC</sub>	50 pF	0.3 V

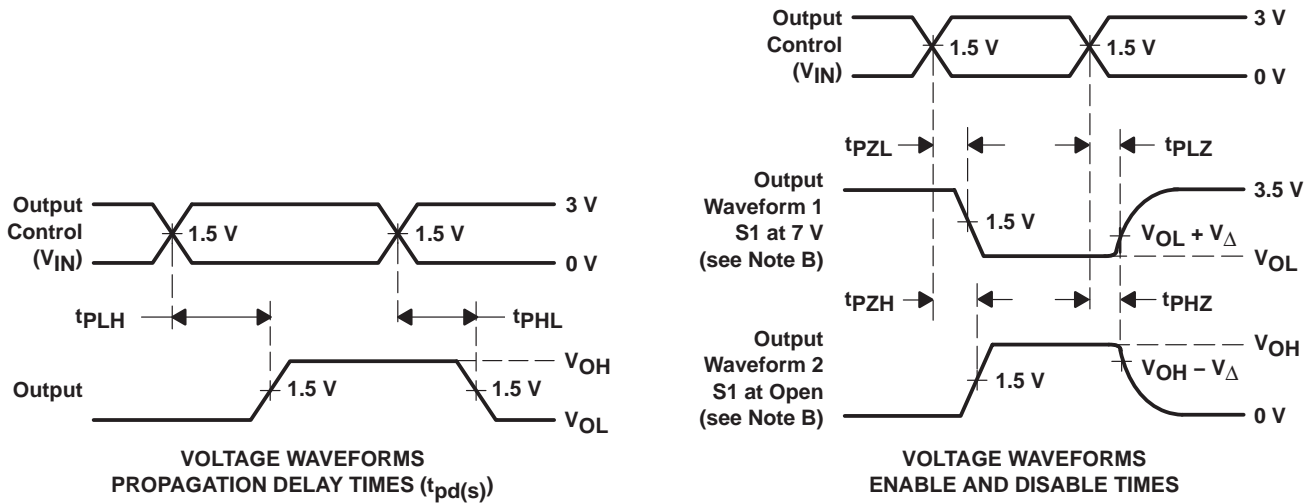

- NOTES: A. C<sub>L</sub> includes probe and jig capacitance.  
 B. Waveform 1 is for an output with internal conditions such that the output is low except when disabled by the output control. Waveform 2 is for an output with internal conditions such that the output is high except when disabled by the output control.  
 C. All input pulses are supplied by generators having the following characteristics: PRR ≤ 10 MHz, Z<sub>O</sub> = 50 Ω, t<sub>r</sub> ≤ 2.5 ns, t<sub>f</sub> ≤ 2.5 ns.  
 D. The outputs are measured one at a time with one transition per measurement.  
 E. t<sub>PLZ</sub> and t<sub>PHZ</sub> are the same as t<sub>dis</sub>.  
 F. t<sub>PZL</sub> and t<sub>PZH</sub> are the same as t<sub>en</sub>.  
 G. t<sub>PLH</sub> and t<sub>PHL</sub> are the same as t<sub>pd</sub>(s). The t<sub>pd</sub> propagation delay is the calculated RC time constant of the typical ON-state resistance of the switch and the specified load capacitance, when driven by an ideal voltage source (zero output impedance).  
 H. All parameters and waveforms are not applicable to all devices.

**Figure 1. Test Circuit and Voltage Waveforms**



**PACKAGING INFORMATION**

Orderable Device	Status (1)	Package Type	Package Drawing	Pins	Package Qty	Eco Plan (2)	Lead/Ball Finish (6)	MSL Peak Temp (3)	Op Temp (°C)	Device Marking (4/5)	Samples
SN74CBT16800CDGGR	ACTIVE	TSSOP	DGG	48	2000	Green (RoHS & no Sb/Br)	CU NIPDAU	Level-1-260C-UNLIM	-40 to 85	CBT16800C	<a href="#">Samples</a>
SN74CBT16800CDL	ACTIVE	SSOP	DL	48	25	Green (RoHS & no Sb/Br)	CU NIPDAU	Level-1-260C-UNLIM	-40 to 85	CBT16800C	<a href="#">Samples</a>

(1) The marketing status values are defined as follows:

**ACTIVE:** Product device recommended for new designs.

**LIFEBUY:** TI has announced that the device will be discontinued, and a lifetime-buy period is in effect.

**NRND:** Not recommended for new designs. Device is in production to support existing customers, but TI does not recommend using this part in a new design.

**PREVIEW:** Device has been announced but is not in production. Samples may or may not be available.

**OBSOLETE:** TI has discontinued the production of the device.

(2) Eco Plan - The planned eco-friendly classification: Pb-Free (RoHS), Pb-Free (RoHS Exempt), or Green (RoHS & no Sb/Br) - please check <http://www.ti.com/productcontent> for the latest availability information and additional product content details.

**TBD:** The Pb-Free/Green conversion plan has not been defined.

**Pb-Free (RoHS):** TI's terms "Lead-Free" or "Pb-Free" mean semiconductor products that are compatible with the current RoHS requirements for all 6 substances, including the requirement that lead not exceed 0.1% by weight in homogeneous materials. Where designed to be soldered at high temperatures, TI Pb-Free products are suitable for use in specified lead-free processes.

**Pb-Free (RoHS Exempt):** This component has a RoHS exemption for either 1) lead-based flip-chip solder bumps used between the die and package, or 2) lead-based die adhesive used between the die and leadframe. The component is otherwise considered Pb-Free (RoHS compatible) as defined above.

**Green (RoHS & no Sb/Br):** TI defines "Green" to mean Pb-Free (RoHS compatible), and free of Bromine (Br) and Antimony (Sb) based flame retardants (Br or Sb do not exceed 0.1% by weight in homogeneous material)

(3) MSL, Peak Temp. - The Moisture Sensitivity Level rating according to the JEDEC industry standard classifications, and peak solder temperature.

(4) There may be additional marking, which relates to the logo, the lot trace code information, or the environmental category on the device.

(5) Multiple Device Markings will be inside parentheses. Only one Device Marking contained in parentheses and separated by a "~" will appear on a device. If a line is indented then it is a continuation of the previous line and the two combined represent the entire Device Marking for that device.

(6) Lead/Ball Finish - Orderable Devices may have multiple material finish options. Finish options are separated by a vertical ruled line. Lead/Ball Finish values may wrap to two lines if the finish value exceeds the maximum column width.

**Important Information and Disclaimer:** The information provided on this page represents TI's knowledge and belief as of the date that it is provided. TI bases its knowledge and belief on information provided by third parties, and makes no representation or warranty as to the accuracy of such information. Efforts are underway to better integrate information from third parties. TI has taken and continues to take reasonable steps to provide representative and accurate information but may not have conducted destructive testing or chemical analysis on incoming materials and chemicals. TI and TI suppliers consider certain information to be proprietary, and thus CAS numbers and other limited information may not be available for release.

In no event shall TI's liability arising out of such information exceed the total purchase price of the TI part(s) at issue in this document sold by TI to Customer on an annual basis.

## TAPE AND REEL INFORMATION



### QUADRANT ASSIGNMENTS FOR PIN 1 ORIENTATION IN TAPE

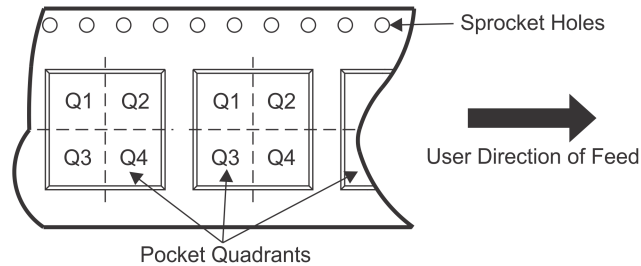

\*All dimensions are nominal

Device	Package Type	Package Drawing	Pins	SPQ	Reel Diameter (mm)	Reel Width W1 (mm)	A0 (mm)	B0 (mm)	K0 (mm)	P1 (mm)	W (mm)	Pin1 Quadrant
SN74CBT16800CDGGR	TSSOP	DGG	48	2000	330.0	24.4	8.6	13.0	1.8	12.0	24.0	Q1

**TAPE AND REEL BOX DIMENSIONS**



\*All dimensions are nominal

Device	Package Type	Package Drawing	Pins	SPQ	Length (mm)	Width (mm)	Height (mm)
SN74CBT16800CDGGR	TSSOP	DGG	48	2000	367.0	367.0	45.0

# MECHANICAL DATA

DL (R-PDSO-G48)

PLASTIC SMALL-OUTLINE PACKAGE



- NOTES:
- All linear dimensions are in inches (millimeters).
  - This drawing is subject to change without notice.
  - Body dimensions do not include mold flash or protrusion not to exceed 0.006 (0,15).
  - Falls within JEDEC MO-118

PowerPAD is a trademark of Texas Instruments.

DGG (R-PDSO-G\*\*)

PLASTIC SMALL-OUTLINE PACKAGE

48 PINS SHOWN



- NOTES: A. All linear dimensions are in millimeters.  
 B. This drawing is subject to change without notice.  
 C. Body dimensions do not include mold protrusion not to exceed 0,15.  
 D. Falls within JEDEC MO-153

## IMPORTANT NOTICE

Texas Instruments Incorporated (TI) reserves the right to make corrections, enhancements, improvements and other changes to its semiconductor products and services per JESD46, latest issue, and to discontinue any product or service per JESD48, latest issue. Buyers should obtain the latest relevant information before placing orders and should verify that such information is current and complete.

TI's published terms of sale for semiconductor products (<http://www.ti.com/sc/docs/stdterms.htm>) apply to the sale of packaged integrated circuit products that TI has qualified and released to market. Additional terms may apply to the use or sale of other types of TI products and services.

Reproduction of significant portions of TI information in TI data sheets is permissible only if reproduction is without alteration and is accompanied by all associated warranties, conditions, limitations, and notices. TI is not responsible or liable for such reproduced documentation. Information of third parties may be subject to additional restrictions. Resale of TI products or services with statements different from or beyond the parameters stated by TI for that product or service voids all express and any implied warranties for the associated TI product or service and is an unfair and deceptive business practice. TI is not responsible or liable for any such statements.

Buyers and others who are developing systems that incorporate TI products (collectively, "Designers") understand and agree that Designers remain responsible for using their independent analysis, evaluation and judgment in designing their applications and that Designers have full and exclusive responsibility to assure the safety of Designers' applications and compliance of their applications (and of all TI products used in or for Designers' applications) with all applicable regulations, laws and other applicable requirements. Designer represents that, with respect to their applications, Designer has all the necessary expertise to create and implement safeguards that (1) anticipate dangerous consequences of failures, (2) monitor failures and their consequences, and (3) lessen the likelihood of failures that might cause harm and take appropriate actions. Designer agrees that prior to using or distributing any applications that include TI products, Designer will thoroughly test such applications and the functionality of such TI products as used in such applications.

TI's provision of technical, application or other design advice, quality characterization, reliability data or other services or information, including, but not limited to, reference designs and materials relating to evaluation modules, (collectively, "TI Resources") are intended to assist designers who are developing applications that incorporate TI products; by downloading, accessing or using TI Resources in any way, Designer (individually or, if Designer is acting on behalf of a company, Designer's company) agrees to use any particular TI Resource solely for this purpose and subject to the terms of this Notice.

TI's provision of TI Resources does not expand or otherwise alter TI's applicable published warranties or warranty disclaimers for TI products, and no additional obligations or liabilities arise from TI providing such TI Resources. TI reserves the right to make corrections, enhancements, improvements and other changes to its TI Resources. TI has not conducted any testing other than that specifically described in the published documentation for a particular TI Resource.

Designer is authorized to use, copy and modify any individual TI Resource only in connection with the development of applications that include the TI product(s) identified in such TI Resource. NO OTHER LICENSE, EXPRESS OR IMPLIED, BY ESTOPPEL OR OTHERWISE TO ANY OTHER TI INTELLECTUAL PROPERTY RIGHT, AND NO LICENSE TO ANY TECHNOLOGY OR INTELLECTUAL PROPERTY RIGHT OF TI OR ANY THIRD PARTY IS GRANTED HEREIN, including but not limited to any patent right, copyright, mask work right, or other intellectual property right relating to any combination, machine, or process in which TI products or services are used. Information regarding or referencing third-party products or services does not constitute a license to use such products or services, or a warranty or endorsement thereof. Use of TI Resources may require a license from a third party under the patents or other intellectual property of the third party, or a license from TI under the patents or other intellectual property of TI.

TI RESOURCES ARE PROVIDED "AS IS" AND WITH ALL FAULTS. TI DISCLAIMS ALL OTHER WARRANTIES OR REPRESENTATIONS, EXPRESS OR IMPLIED, REGARDING RESOURCES OR USE THEREOF, INCLUDING BUT NOT LIMITED TO ACCURACY OR COMPLETENESS, TITLE, ANY EPIDEMIC FAILURE WARRANTY AND ANY IMPLIED WARRANTIES OF MERCHANTABILITY, FITNESS FOR A PARTICULAR PURPOSE, AND NON-INFRINGEMENT OF ANY THIRD PARTY INTELLECTUAL PROPERTY RIGHTS. TI SHALL NOT BE LIABLE FOR AND SHALL NOT DEFEND OR INDEMNIFY DESIGNER AGAINST ANY CLAIM, INCLUDING BUT NOT LIMITED TO ANY INFRINGEMENT CLAIM THAT RELATES TO OR IS BASED ON ANY COMBINATION OF PRODUCTS EVEN IF DESCRIBED IN TI RESOURCES OR OTHERWISE. IN NO EVENT SHALL TI BE LIABLE FOR ANY ACTUAL, DIRECT, SPECIAL, COLLATERAL, INDIRECT, PUNITIVE, INCIDENTAL, CONSEQUENTIAL OR EXEMPLARY DAMAGES IN CONNECTION WITH OR ARISING OUT OF TI RESOURCES OR USE THEREOF, AND REGARDLESS OF WHETHER TI HAS BEEN ADVISED OF THE POSSIBILITY OF SUCH DAMAGES.

Unless TI has explicitly designated an individual product as meeting the requirements of a particular industry standard (e.g., ISO/TS 16949 and ISO 26262), TI is not responsible for any failure to meet such industry standard requirements.

Where TI specifically promotes products as facilitating functional safety or as compliant with industry functional safety standards, such products are intended to help enable customers to design and create their own applications that meet applicable functional safety standards and requirements. Using products in an application does not by itself establish any safety features in the application. Designers must ensure compliance with safety-related requirements and standards applicable to their applications. Designer may not use any TI products in life-critical medical equipment unless authorized officers of the parties have executed a special contract specifically governing such use. Life-critical medical equipment is medical equipment where failure of such equipment would cause serious bodily injury or death (e.g., life support, pacemakers, defibrillators, heart pumps, neurostimulators, and implantables). Such equipment includes, without limitation, all medical devices identified by the U.S. Food and Drug Administration as Class III devices and equivalent classifications outside the U.S.

TI may expressly designate certain products as completing a particular qualification (e.g., Q100, Military Grade, or Enhanced Product). Designers agree that it has the necessary expertise to select the product with the appropriate qualification designation for their applications and that proper product selection is at Designers' own risk. Designers are solely responsible for compliance with all legal and regulatory requirements in connection with such selection.

Designer will fully indemnify TI and its representatives against any damages, costs, losses, and/or liabilities arising out of Designer's non-compliance with the terms and provisions of this Notice.

## Looking for pricing, stock, or lifecycle information?

Click below to explore more details on WIN SOURCE:

 [View SN74CBT16800CDGVR on WIN SOURCE](#)

 [Texas Instruments](#) Information

## Optimize Your Supply Chain with WIN SOURCE Solutions

-  Global Sourcing Solution
-  Obsolete Management
-  Cost Control Management
-  Shortage Management
-  Alternative Solution
-  Excess Inventory Management