

General Description

The SPX29300/01/02 are 3A, highly accurate voltage regulators with a low dropout voltage of 600mV (typical) at 3A.

These regulators are specifically designed for low voltage applications that require a low dropout voltage and a fast transient response. They are fully fault protected against over-current, reverse battery, and positive and negative voltage transients. On-Chip trimming adjusts the reference voltage to 1% initial accuracy.

The SPX29300 is offered in a 3-pin TO-263 package, the SPX29301 and SPX29302 are offered in a 5-pin TO-263 package.

Features

- 3A guaranteed output current
- Low dropout voltage of 600mV @ 3A
- Adjustable output down to 1.25V
- 1% output accuracy
- Tight load and line regulation
- Fast transient response
- Reverse battery protection
- Zero current shutdown (SPX29301/02)
- Power Good flag (SPX29301)
- Lead free 3-pin TO-263 and 5-pin TO-263 packages

Applications

- Adjustable power supplies
- Constant current regulators
- Audio and video / graphic cards
- Battery chargers

Ordering Information - [page 9](#)

Typical Application Diagram

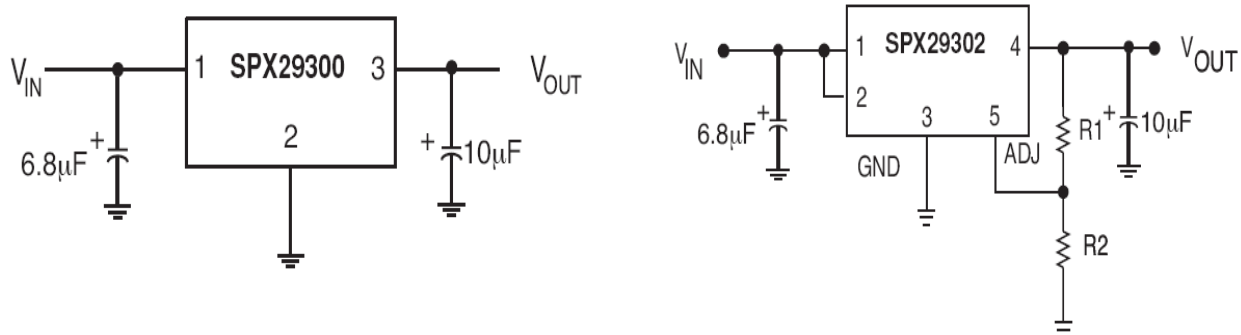

Figure 1: SPX29300 and SPX29302 Application Diagrams

Revision History

Revision	Release Date	Change Description
1.0.0	12/17/2009	Initial Release of Datasheet.
2.0.0	3/31/2010	Reformat of datasheet Inserted ESD data Modified Dropout Voltage and Ground Current values in electrical characteristics table Corrected typographical error in result of calculus in note 8 Removed "Gound Current vs Load Current", "Enable Threshold vs Temperature" and "Power Supply Rejection Ratio curves" Updated "Dropout Voltage vs Load Current", "Line Regulation" and "Load Regulation" curves Added "start Up" curve
2.1.0	10/19/2010	Corrected Adjustable Regulator Design paragraph equation
2.2.0	12/21/2016	Updated package specification and ordering information.
2.2.1	8/30/2019	Updated to MaxLinear format. Updated ordering information and moved to end. Obsolete 1.8V version (SPX29300T-L-1-8/TR) removed.
2.2.2	12/15/2020	Clarified that package tabs are GND on pinout.

Table of Contents

General Description	i
Features	i
Applications	i
Typical Application Diagram	i
Specifications	1
Absolute Maximum Ratings.....	1
ESD Ratings	1
Operating Ratings	1
Electrical Characteristics	2
Block Diagram	4
Pin Information	4
Typical Performance Characteristics	5
Theory of Operation	6
Thermal Considerations	6
TO-263 Design Example	6
Capacitor Requirements.....	6
Minimum Load Current.....	6
Adjustable Regulator Design	6
Error Flag	6
Enable Input	6
Typical Application Circuits	6
Mechanical Dimensions	7
Ordering Information	9

List of Figures

Figure 1: SPX29300 and SPX29302 Application Diagrams	i
Figure 2: SPX29300, SPX29301, SPX29302 Block Diagram.....	4
Figure 3: SPX29300, SPX29301, SPX29302 Pin Assignments	4
Figure 4: Dropout Voltage vs. Load Current	5
Figure 5: Startup	5
Figure 6: Line Regulation $I_{OUT} = 10\text{mA}$, $V_{OUT} = 3.3\text{V}$	5
Figure 7: Load Regulation $V_{OUT} = 3.3\text{V}$	5
Figure 8: Mechanical Dimensions, 3-pin and 5-pin TO-263	7
Figure 9: Mechanical Dimensions, 3-pin and 5-pin TO-263	8

List of Tables

Table 1: Absolute Maximum Ratings	1
Table 2: ESD Ratings	1
Table 3: Operating Ratings.....	1
Table 4: Electrical Characteristics	2
Table 5: Ordering Information.....	9

Specifications

Absolute Maximum Ratings

Important: These are stress rating only and functional operation of the device at these ratings or any other above those indicated in the operation sections of the specifications below is not implied. Exposure to absolute maximum ratings conditions for extended periods of time may affect reliability.

Table 1: Absolute Maximum Ratings

Parameter	Minimum	Maximum	Units
Input voltage $V_{IN}^{(1)}$		20.0	V
Storage temperature	-65	150	°C
Lead temperature (soldering, 5 sec)		260	°C

1. Maximum positive supply voltage of 20V must be of limited duration (<100ms) and duty cycle of less than 1%. The maximum continuous supply voltage is 16V.

ESD Ratings

Table 2: ESD Ratings

Parameter	Value	Units
HBM (Human Body Model) all pins except EN	2	kV
HBM (Human Body Model) EN pin	1	kV

Operating Ratings

Table 3: Operating Ratings

Parameter	Value	Units
Input voltage range V_{IN}	16	V
Junction temperature range	-40 to 125	°C
Thermal Resistance		
TO-263-3 junction to ambient	31.4	°C/W
TO-263-5 junction to ambient	31.2	°C/W
TO-263-3, TO-263-5 junction to case	3	°C/W

Electrical Characteristics

Specifications with standard type are for an Operating Junction Temperature of $T_J = T_A = 25^\circ\text{C}$ only; limits applying over the full Operating Junction Temperature range are denoted by a "•". Minimum and Maximum limits are guaranteed through test, design, or statistical correlation. Typical values represent the most likely parametric norm at $T_J = 25^\circ\text{C}$, and are provided for reference purposes only. Unless otherwise noted, $V_{IN} = V_{OUT} + 1\text{V}$ and $I_{OUT} = 10\text{mA}$. $C_{IN} = 6.8\mu\text{F}$, $C_{OUT} = 10\mu\text{F}$, $T_A = 25^\circ\text{C}$.

Table 4: Electrical Characteristics

Parameter	Test Condition	Minimum	Typical	Maximum	Units	
Fixed Voltage Versions						
Output voltage, 2.5V version	$I_{OUT} = 10\text{mA}$	2.475	2.500	2.525	V	
	$10\text{mA} \leq I_{OUT} \leq 3\text{A}$, $3.5\text{V} \leq V_{IN} \leq 16\text{V}$	• 2.450	2.500	2.550		
Output voltage, 3.3V version	$I_{OUT} = 10\text{mA}$	3.267	3.300	3.333	V	
	$10\text{mA} \leq I_{OUT} \leq 3\text{A}$, $4.3\text{V} \leq V_{IN} \leq 16\text{V}$	• 3.234	3.300	3.366		
Output voltage, 5.0V version	$I_{OUT} = 10\text{mA}$	4.950	5.000	5.050	V	
	$10\text{mA} \leq I_{OUT} \leq 3\text{A}$, $6.0\text{V} \leq V_{IN} \leq 16\text{V}$	• 4.900	5.000	5.100		
All Voltage Versions						
Line regulation	$I_{OUT} = 10\text{mA}$, $(V_{OUT} + 1\text{V}) \leq V_{IN} \leq 16\text{V}$		0.06	0.5	%	
Load regulation	$V_{IN} = V_{OUT} + 1\text{V}$, $10\text{mA} \leq I_{OUT} \leq I_{FL}^{(2)}$		0.2	1	%	
$\Delta V / \Delta T$	V_{OUT} temp coefficient ⁽⁶⁾	•	20	100	ppm/ $^\circ\text{C}$	
Dropout voltage ⁽³⁾	$I_{OUT} = 100\text{mA}$	•	120	300	mV	
	$I_{OUT} = 1.5\text{A}$		380			
	$I_{OUT} = 3\text{A}$	•	600	800		
Ground current ⁽⁵⁾	$I_{OUT} = 1.5\text{A}$	•	30	60	mA	
	$I_{OUT} = 3\text{A}$		40			
Ground pin current at dropout	$V_{IN} = 0.5\text{V}$ less than specified V_{OUT} , $I_{OUT} = 10\text{mA}$		0.9		mA	
Current limit	$V_{OUT} = 0\text{V}^{(4)}$		3.0	4.5	A	
Output noise voltage	10Hz - 100kHz, $I_{OUT} = 100\text{mA}$, $C_{OUT} = 10\mu\text{F}$		400		μV_{RMS}	
	10Hz - 100kHz, $I_{OUT} = 100\text{mA}$, $C_{OUT} = 33\mu\text{F}$		260			
Reference voltage temperature coefficient ⁽⁷⁾			20		ppm/ $^\circ\text{C}$	
Reference Voltage and Adjustable Pin - SPX29302						
Reference voltage			1.228	1.24	1.252	V
		•	1.215		1.265	
	$V_{REF} \leq V_{OUT} \leq (V_{IN} - 1)$, $2.3 \leq V_{IN} \leq 16\text{V}$, $10\text{mA} \leq I_L \leq I_{FL}$, $T_J < T_{J\text{MAX}}$		1.203		1.277	
Adjust pin bias current			40	80	nA	
	•			120		
Adjust pin bias current temperature coefficient			0.1		nA/ $^\circ\text{C}$	

Table 4: Electrical Characteristics

Parameter	Test Condition	Minimum	Typical	Maximum	Units
Power Good Flag Output - SPX29301					
Output leakage current	$V_{OH} = 16V$		0.01	1	μA
		•		2	
Output low voltage	Device set for 5V, $V_{IN} = 4.5V$, $I_{OL} = 250\mu A$		220	300	mV
		•		400	
Upper threshold voltage	Device set for 5V ⁽⁸⁾		40	60	mV
		•	25		
Lower threshold voltage	Device set for 5V ⁽⁸⁾		75	95	mV
		•		140	
Hysteresis	Device set for 5V ⁽⁸⁾		15		mV
Enable Input - SPX29301 / 02					
Input logic voltage low (OFF)	$V_{IN} < 10V$	•		0.8	V
Input logic voltage high (ON)		•	2.4		
Enable input pin	$V_{EN} = 16V$		100	600	μA
		•		750	
	$V_{EN} = 0.8V$	•		1	
		•		2	
Regulator output current in shutdown ⁽⁹⁾		•	10	500	μA

2. Full load current (I_{FL}) is defined as 3.0A.

3. Dropout voltage is defined ($V_{IN} - V_{OUT}$) when the output voltage drops to 99% of its nominal value.

4. $V_{IN} = V_{OUT(nom)} + 1V$. Use pulse-testing procedures to minimize temperature rise.

5. Ground pin current is the regulator quiescent current. The total current drawn from the source is the sum of the load current to the ground current.

6. Output voltage temperature coefficient is defined as the worst case voltage change divided by the total temperature range.

7. Thermal regulation is defined as the change in output voltage at time T after a change in power dissipation is applied, excluding load / line regulation effects. Specifications for a 200mA load pulse as $V_{IN} = 20V$ (a 4W pulse) for $t = 10ms$.

8. Comparator threshold is expressed in terms of a voltage differential at the Adjust terminal below the nominal reference voltage measured 6V input. To express these thresholds in terms of output voltage change, multiply the error amplifier gain = $V_{OUT} / V_{REF} = (R1 + R2) / R2$. For example, at a programmable output voltage of 5V, the Error output is guaranteed to go low when the output drops by $95mV \times 5V / 1.240V = 383mV$. Threshold remains constant as a percent of V_{OUT} as V_{OUT} is varied, with the dropout warning occurring at typically 5% below nominal, 7.7% guaranteed.

9. $V_{EN} \leq 0.8V$ and $V_{IN} \leq 16V$, $V_{OUT} = 0V$.

Block Diagram

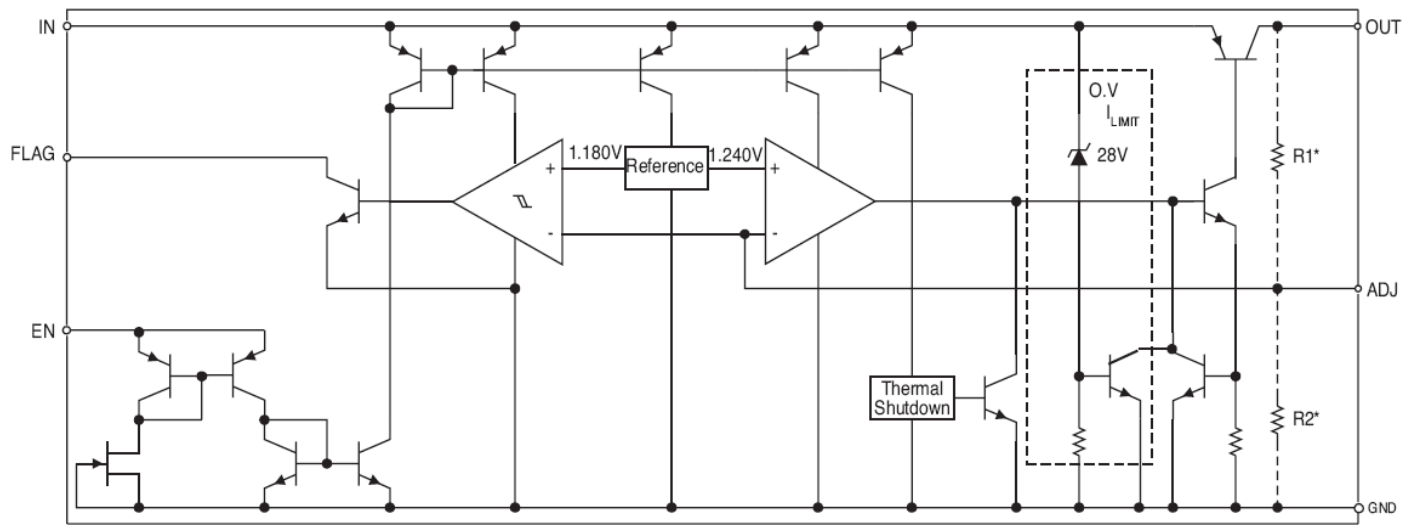
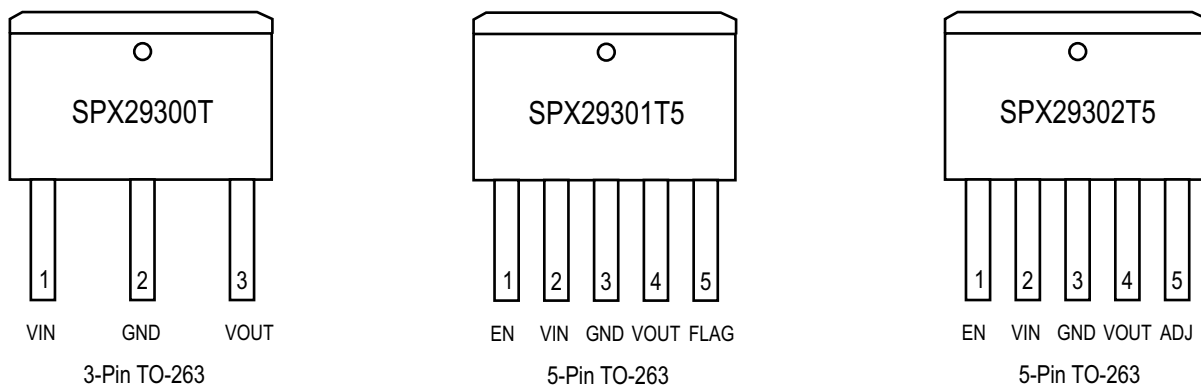

Figure 2: SPX29300, SPX29301, SPX29302 Block Diagram

Pin Information⁽¹⁾



1. On all devices, the Tab is GND.

Figure 3: SPX29300, SPX29301, SPX29302 Pin Assignments

Typical Performance Characteristics

All data taken at $V_{IN} = V_{OUT} + 1V$, $T_J = T_A = 25^\circ C$, unless otherwise specified.

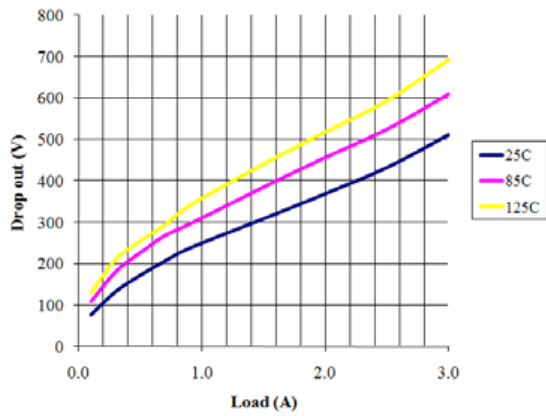

Figure 4: Dropout Voltage vs. Load Current

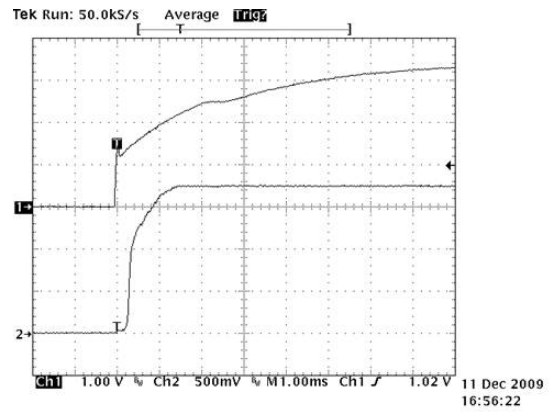

Figure 5: Startup

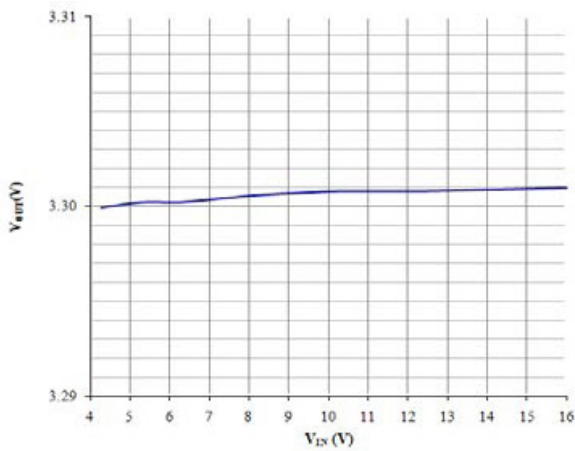

Figure 6: Line Regulation: $I_{OUT} = 10mA$, $V_{OUT} = 3.3V$

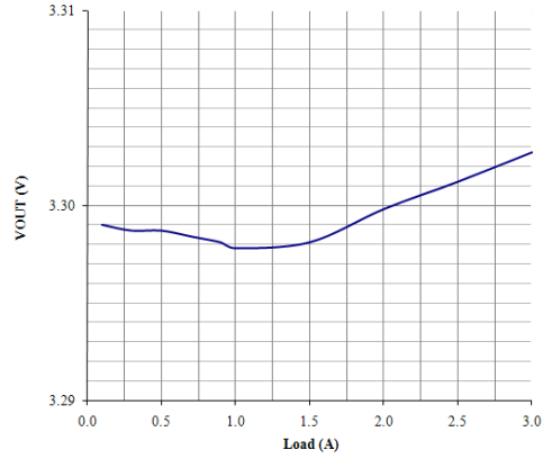

Figure 7: Load Regulation: $V_{OUT} = 3.3V$

Theory of Operation

The SPX29300/01/02 incorporates protection against over-current faults, reversed load insertion, over temperature operation, and positive and negative transient voltage.

Thermal Considerations

Although the SPX29300/01/02 offers limiting circuitry for overload conditions, it is still necessary to insure that the maximum junction temperature is not exceeded in the application. Heat will flow through the lowest resistance path, the junction-to-case path. In order to insure the best thermal flow of the component, proper mounting is required.

TO-263 Design Example

Assume that $V_{IN} = 5V$, $V_{OUT} = 3.3V$, $I_{OUT} = 1.0A$, $T_A = 50^\circ C$ and $\theta_{JA} = 31.4^\circ C/W$, where:

T_A = ambient temperature,

θ_{JA} = junction to ambient thermal resistance

The power calculated under these conditions is:

$$P_D = (V_{IN} - V_{OUT}) \times I_{OUT} = 1.7W$$

And the junction temperature is calculated as

$$T_J = T_A + P_D \times \theta_{JA}$$

or

$$T_J = 50 + 1.7 \times 31.4 = 103.4^\circ C$$

Reliable operation is insured.

Capacitor Requirements

The output capacitor is needed to insure stability and minimize the output noise. The value of the capacitor varies with the load. However, a minimum value of 10 μ F aluminum capacitor will guarantee stability over all load conditions.

A tantalum capacitor is recommended if a faster load transient response is needed. If the power source has high AC impedance, a 0.1 μ F ceramic capacitor between input and ground is recommended.

Minimum Load Current

To ensure a proper behavior of the regulator under light load, a minimum load of 5mA for SPX29300/01/02 is required.

Adjustable Regulator Design

The SPX29300/01/02 is an adjustable regulator that can be programmed to any value between 1.25V and 16V using 2 external resistors, R1 and R2. The relationship between the resistors and the output voltage is:

$$R_1 = R_2 \times \left(\frac{V_{OUT}}{1.240} - 1 \right)$$

Error Flag

The SPX29301 features an error flag that indicates either an over current or under current voltage condition. The flag output goes low, sinking 10mA when either condition occurs.

Enable Input

The SPX29301/02 has an Enable function that switches the regulator on and off. Its thresholds are TTL compatible. When the regulator is active, approximately 20 μ A flows through the Enable pin.

Typical Application Circuits

Figure 1 represents the typical implementation for an adjustable output regulator. The values of R1 and R2 set the output voltage value as follows:

$$V_{OUT} = V_{REF} \times \left(1 + \frac{R_1}{R_2} \right)$$

A minimum value of 10k Ω is recommended for R2 with a range between 10k Ω and 47k Ω .

Mechanical Dimensions

3-pin and 5-pin TO-263

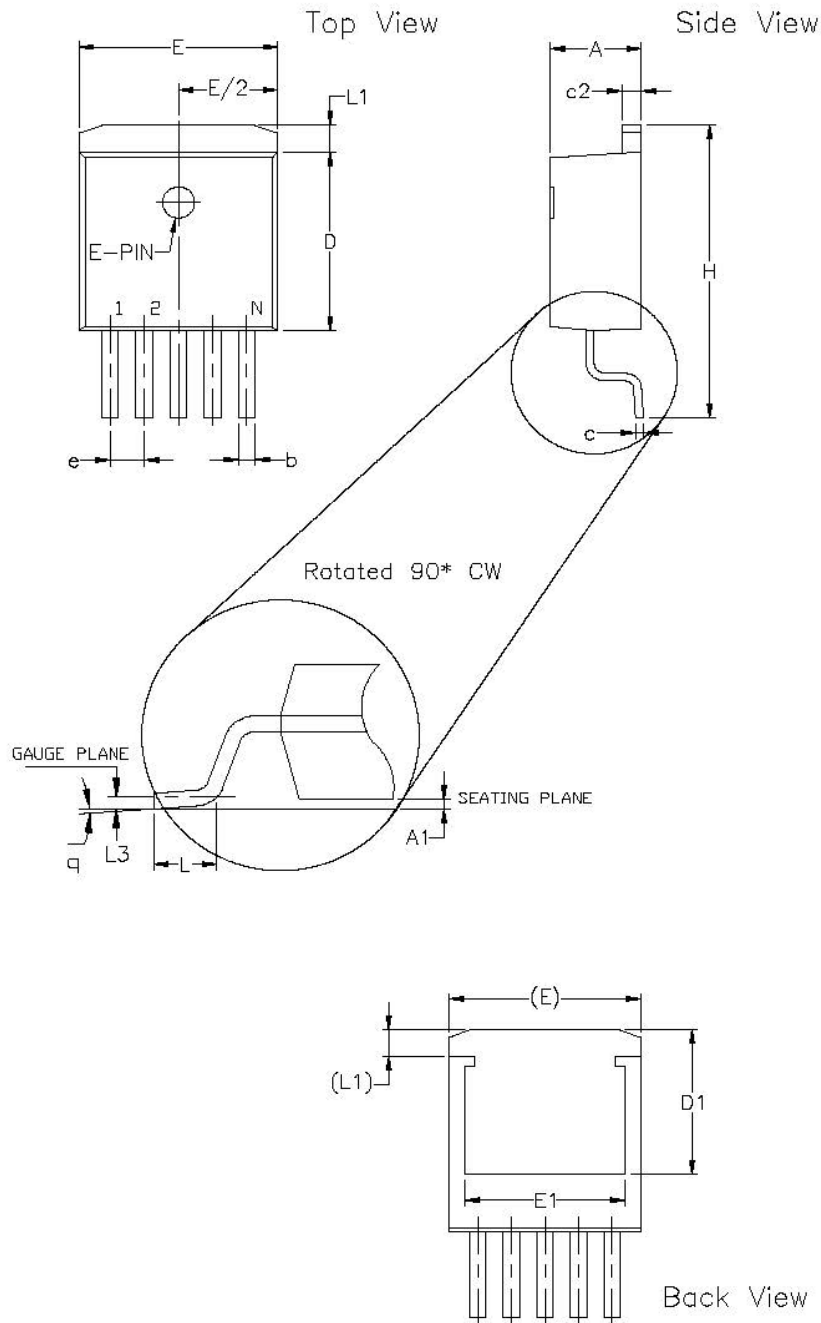

Drawing No: POD-0000021
 Revision: A

Figure 8: Mechanical Dimensions, 3-pin and 5-pin TO-263

Mechanical Dimensions, continued

3-pin and 5-pin TO-263, continued

3 Pin TO-263 JEDEC TO-263 Variation AA						
SYMBOLS	DIMENSIONS IN INCH (Control Unit)			DIMENSIONS IN MM (Reference Unit)		
	MIN	NOM	MAX	MIN	NOM	MAX
A	0.160	—	0.190	4.06	—	4.83
A1	0.000	—	0.010	0.00	—	0.25
b	0.020	—	0.039	0.51	—	0.99
b2	0.045	—	0.070	1.14	—	1.78
c	0.015	—	0.029	0.38	—	0.74
c2	0.045	—	0.065	1.14	—	1.65
D	0.330	—	0.380	8.38	—	9.65
D1	0.270	—	—	6.86	—	—
E	0.380	—	0.420	9.65	—	10.67
E1	0.245	—	—	6.22	—	—
e	0.100 BSC			2.54 BSC		
H	0.575	—	0.625	14.61	—	15.88
L	0.070	—	0.110	1.78	—	2.79
L1	—	—	0.066	—	—	1.68
L3	0.010 BSC			0.25 BSC		
Q	0°	—	8°	0°	—	8°
N	3			3		

5 Pin TO-263 JEDEC TO-263 Variation BA						
SYMBOLS	DIMENSIONS IN INCH (Control Unit)			DIMENSIONS IN MM (Reference Unit)		
	MIN	NOM	MAX	MIN	NOM	MAX
A	0.160	—	0.190	4.06	—	4.83
A1	0.000	—	0.010	0.00	—	0.25
b	0.020	—	0.039	0.51	—	0.99
c	0.015	—	0.029	0.38	—	0.74
c2	0.045	—	0.065	1.14	—	1.65
D	0.330	—	0.380	8.38	—	9.65
D1	0.270	—	—	6.86	—	—
E	0.380	—	0.420	9.65	—	10.67
E1	0.245	—	—	6.22	—	—
e	0.067 BSC			1.70 BSC		
H	0.575	—	0.625	14.61	—	15.88
L	0.070	—	0.110	1.78	—	2.79
L1	—	—	0.066	—	—	1.68
L3	0.010 BSC			0.25 BSC		
Q	0°	—	8°	0°	—	8°
N	5			5		

Drawing No: POD-0000021
Revision: A

Figure 9: Mechanical Dimensions, 3-pin and 5-pin TO-263, continued

Ordering Information

Table 5: Ordering Information

Ordering Part Number	Operating Temperature Range	Package	Packaging Method	Lead-Free ⁽²⁾
SPX29300T-L-2-5/TR	$-40^{\circ}\text{C} \leq T_J \leq 125^{\circ}\text{C}$	3-pin TO-263	Tape and Reel	Yes
SPX29300T-L-3-3/TR	$-40^{\circ}\text{C} \leq T_J \leq 125^{\circ}\text{C}$	3-pin TO-263	Tape and Reel	Yes
SPX29300T-L-5-0/TR	$-40^{\circ}\text{C} \leq T_J \leq 125^{\circ}\text{C}$	3-pin TO-263	Tape and Reel	Yes
SPX29301T5-L-5-0/TR	$-40^{\circ}\text{C} \leq T_J \leq 125^{\circ}\text{C}$	5-pin TO-263	Tape and Reel	Yes
SPX29302T5-L/TR	$-40^{\circ}\text{C} \leq T_J \leq 125^{\circ}\text{C}$	5-pin TO-263	Tape and Reel	Yes

1. Refer to www.maxlinear.com/SPX29300, www.maxlinear.com/SPX29301, and www.maxlinear.com/SPX29302 for most up-to-date Ordering Information.

2. Visit www.maxlinear.com for additional information on Environmental Rating.



MaxLinear, Inc.
5966 La Place Court, Suite 100
Carlsbad, CA 92008
760.692.0711 p.
760.444.8598 f.
www.maxlinear.com

The content of this document is furnished for informational use only, is subject to change without notice, and should not be construed as a commitment by MaxLinear, Inc. MaxLinear, Inc. assumes no responsibility or liability for any errors or inaccuracies that may appear in the informational content contained in this guide. Complying with all applicable copyright laws is the responsibility of the user. Without limiting the rights under copyright, no part of this document may be reproduced into, stored in, or introduced into a retrieval system, or transmitted in any form or by any means (electronic, mechanical, photocopying, recording, or otherwise), or for any purpose, without the express written permission of MaxLinear, Inc.



MaxLinear, Inc. does not recommend the use of any of its products in life support applications where the failure or malfunction of the product can reasonably be expected to cause failure of the life support system or to significantly affect its safety or effectiveness. Products are not authorized for use in such applications unless MaxLinear, Inc. receives, in writing, assurances to its satisfaction that: (a) the risk of injury or damage has been minimized; (b) the user assumes all such risks; (c) potential liability of MaxLinear, Inc. is adequately protected under the circumstances.

MaxLinear, Inc. may have patents, patent applications, trademarks, copyrights, or other intellectual property rights covering subject matter in this document. Except as expressly provided in any written license agreement from MaxLinear, Inc., the furnishing of this document does not give you any license to these patents, trademarks, copyrights, or other intellectual property.

MaxLinear, the MaxLinear logo, and any MaxLinear trademarks, MxL, Full-Spectrum Capture, FSC, G.now, AirPHY, Puma, AnyWAN and the MaxLinear logo are all on the products sold, are all trademarks of MaxLinear, Inc. or one of MaxLinear's subsidiaries in the U.S.A. and other countries. All rights reserved. Other company trademarks and product names appearing herein are the property of their respective owners.

Looking for pricing, stock, or lifecycle information?

Click below to explore more details on WIN SOURCE:

-  [View SPX29301T5-L-3-3 on WIN SOURCE](#)
-  [MaxLinear Inc Information](#)

Optimize Your Supply Chain with WIN SOURCE Solutions

-  Global Sourcing Solution
-  Obsolete Management
-  Cost Control Management
-  Shortage Management
-  Alternative Solution
-  Excess Inventory Management