



**THE DATASHEET OF
ADF4157BRUZ-RL7**



FEATURES

- RF bandwidth to 6 GHz**
- 25-bit fixed modulus allows subhertz frequency resolution**
- 2.7 V to 3.3 V power supply**
- Separate V_p allows extended tuning voltage**
- Programmable charge pump currents**
- 3-wire serial interface**
- Digital lock detect**
- Power-down mode**
- Pin compatible with the following frequency synthesizers:**
 - ADF4110/ADF4111/ADF4112/ADF4113/
 - ADF4106/ADF4153/ADF4154/ADF4156
- Cycle slip reduction for faster lock times**

APPLICATIONS

- Satellite communications terminals, radar equipment**
- Instrumentation equipment**
- Personal mobile radio (PMR)**
- Base stations for mobile radio**
- Wireless handsets**

GENERAL DESCRIPTION

The ADF4157 is a 6 GHz fractional-N frequency synthesizer with a 25-bit fixed modulus, allowing subhertz frequency resolution at 6 GHz. It consists of a low noise digital phase frequency detector (PFD), a precision charge pump, and a programmable reference divider. There is a Σ - Δ based fractional interpolator to allow programmable fractional-N division. The INT and FRAC values define an overall N divider, $N = INT + (FRAC/2^{25})$. The ADF4157 features cycle slip reduction circuitry, which leads to faster lock times without the need for modifications to the loop filter.

Control of all on-chip registers is via a simple 3-wire interface. The device operates with a power supply ranging from 2.7 V to 3.3 V and can be powered down when not in use.

FUNCTIONAL BLOCK DIAGRAM

Figure 1.

06574-001

Rev. D

Information furnished by Analog Devices is believed to be accurate and reliable. However, no responsibility is assumed by Analog Devices for its use, nor for any infringements of patents or other rights of third parties that may result from its use. Specifications subject to change without notice. No license is granted by implication or otherwise under any patent or patent rights of Analog Devices. Trademarks and registered trademarks are the property of their respective owners.

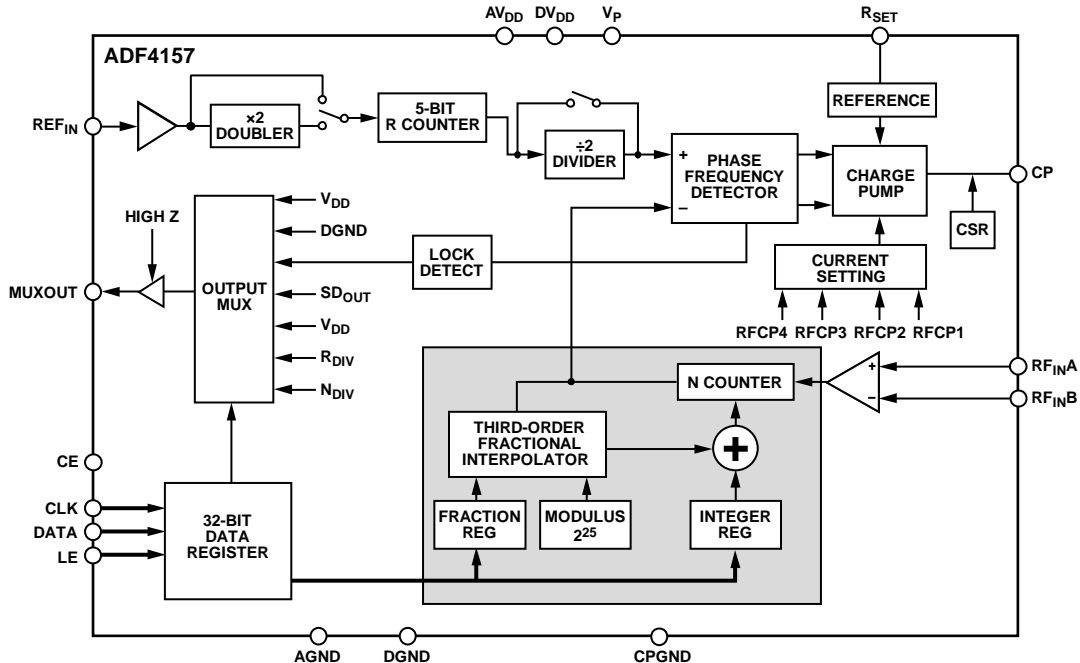
TABLE OF CONTENTS

| | | | |
|---|----|---|----|
| Features | 1 | Program Modes | 10 |
| Applications..... | 1 | Register Maps..... | 11 |
| General Description | 1 | FRAC/INT Register (R0) Map..... | 12 |
| Functional Block Diagram | 1 | LSB FRAC Register (R1) Map | 13 |
| Revision History | 2 | R Divider Register (R2) Map | 14 |
| Specifications..... | 3 | Function Register (R3) Map | 16 |
| Timing Specifications | 4 | Test Register (R4) Map | 17 |
| Absolute Maximum Ratings..... | 5 | Applications Information | 18 |
| Thermal Resistance | 5 | Initialization Sequence | 18 |
| ESD Caution..... | 5 | RF Synthesizer: A Worked Example | 18 |
| Pin Configurations and Function Descriptions | 6 | Reference Doubler and Reference Divider | 18 |
| Typical Performance Characteristics | 8 | Cycle Slip Reduction for Faster Lock Times..... | 18 |
| Circuit Description..... | 9 | Fastlock Timer and Register Sequences | 19 |
| Reference Input Section..... | 9 | Fastlock: An Example | 19 |
| RF Input Stage..... | 9 | Fastlock: Loop Filter Topology..... | 19 |
| RF INT Divider..... | 9 | Spur Mechanisms | 19 |
| 25-Bit Fixed Modulus | 9 | Low Frequency Applications | 20 |
| INT, FRAC, and R Relationship | 9 | Filter Design—ADIsimPLL..... | 20 |
| RF R Counter | 9 | Operating with Wide Loop Filter Bandwidths..... | 20 |
| Phase Frequency Detector (PFD) and Charge Pump..... | 10 | PCB Design Guidelines for the Chip Scale Package..... | 20 |
| MUXOUT and Lock Detect..... | 10 | Outline Dimensions | 21 |
| Input Shift Register..... | 10 | Ordering Guide | 21 |

REVISION HISTORY

8/12—Rev. C to Rev. D

| | |
|---|----|
| Changes to Figure 4 and Table 5..... | 6 |
| Updated Outline Dimensions (Changed CP-20-1 to CP-20-6) | 22 |
| Changes to Ordering Guide | 21 |

Criticizing

3/12—Rev. B to Rev. C

| | |
|---------------------------------|----|
| Changes to Table 1..... | 3 |
| Changes to Ordering Guide | 21 |

9/11—Rev. A to Rev. B

| | |
|--|---|
| Changes to Noise Characteristics Parameter | 3 |
| Changes to EPAD Note..... | 6 |

1/09—Rev. 0 to Rev. A

| | |
|---|---|
| Changes to Figure 1..... | 1 |
| Changes to Reference Characteristics Parameter, Table 1 | 3 |
| Changes to Table 3..... | 5 |

| | |
|---|----|
| Changes to Figure 4 and Table 5..... | 6 |
| Changes to Figure 15..... | 10 |
| Changes to Figure 16..... | 11 |
| Changes to Figure 17..... | 12 |
| Changes to Figure 19..... | 15 |
| Added Negative Bleed Current Section, CLK Divider Mode Section, and 12-Bit Clock Divider Value Section..... | 17 |
| Changes to Reserved Bits Section and Figure 21 | 17 |
| Deleted Interfacing Section..... | 18 |
| Added Fastlock Timer and Register Sequences Section, Fastlock: An Example Section, and Fastlock: Loop Filter Topology Section | 19 |
| Added Figure 22 and Figure 23; Renumbered Sequentially | 19 |
| Added Operating with Wide Loop Filter Bandwidths Section..... | 20 |
| Updated Outline Dimensions | 21 |

7/07—Revision 0: Initial Version

SPECIFICATIONS

$AV_{DD} = DV_{DD} = 2.7 \text{ V to } 3.3 \text{ V}$; $V_P = AV_{DD} \text{ to } 5.5 \text{ V}$; $AGND = DGND = 0 \text{ V}$; $T_A = T_{MIN} \text{ to } T_{MAX}$, unless otherwise noted; dBm referred to 50Ω .

Table 1.

| Parameter | B Version ¹ | Unit | Test Conditions/Comments |
|--|--|--|--|
| RF CHARACTERISTICS (3 V) RF Input Frequency (RF _{IN}) | 0.5/6.0 | GHz min/max | -10 dBm/0 dBm min/max; for lower frequencies, ensure slew rate (SR) > 400 V/μs |
| REFERENCE CHARACTERISTICS REF _{IN} Input Frequency REF _{IN} Input Sensitivity REF _{IN} Input Capacitance REF _{IN} Input Current | 10/300 0.4/AV _{DD} 0.7/AV _{DD} 10 ±100 | MHz min/max V p-p min/max V p-p min/max pF max μA max | For f _{REFIN} < 10 MHz, ensure slew rate > 50 V/μs For 10 MHz < f _{REFIN} < 250 MHz, biased at AV _{DD} /2 ² For 250 MHz < f _{REFIN} < 300 MHz, biased at AV _{DD} /2 ² |
| PHASE DETECTOR Phase Detector Frequency ³ | 32 | MHz max | |
| CHARGE PUMP I _{CP} Sink/Source High Value Low Value Absolute Accuracy R _{SET} Range I _{CP} Three-State Leakage Current Matching I _{CP} vs. V _{CP} I _{CP} vs. Temperature | 5 312.5 2.5 2.7/10 1 2 2 2 | mA typ μA typ % typ kΩ min/max nA typ % typ % typ % typ | Programmable With R _{SET} = 5.1 kΩ With R _{SET} = 5.1 kΩ Sink and source current 0.5 V < V _{CP} < V _P - 0.5 0.5 V < V _{CP} < V _P - 0.5 V _{CP} = V _P /2 |
| LOGIC INPUTS V _{INHr} Input High Voltage V _{INLr} Input Low Voltage I _{INHr} /I _{INLr} Input Current C _{INr} Input Capacitance | 1.4 0.6 ±1 10 | V min V max μA max pF max | |
| LOGIC OUTPUTS V _{OHr} Output High Voltage V _{OHr} Output High Voltage V _{OLr} Output Low Voltage | 1.4 VDD - 0.4 0.4 | V min V min V max | Open-drain 1 kΩ pull-up to 1.8 V CMOS output chosen I _{OL} = 500 μA |
| POWER SUPPLIES AV _{DD} DV _{DD} V _P I _{DD} Low Power Sleep Mode | 2.7/3.3 AV _{DD} AV _{DD} /5.5 29 10 | V min/max V min/V max mA max μA typ | 23 mA typical |
| NOISE CHARACTERISTICS Normalized Phase Noise Floor (PN _{SYNTH}) ⁴ Normalized 1/f Noise (PN _{1/f}) ⁵ Phase Noise Floor ⁶ Phase Noise Performance ⁷ 5800 MHz Output ⁸ | -211 -110 -137 -133 -87 | dBc/Hz typ dBc/Hz typ dBc/Hz typ dBc/Hz typ dBc/Hz typ | PLL loop B/W = 500 kHz; measured at 100 kHz 10 kHz offset; normalized to 1 GHz @ 10 MHz PFD frequency @ 25 MHz PFD frequency @ VCO output @ 2 kHz offset, 25 MHz PFD frequency |

¹ Operating temperature of B version is -40°C to +85°C.

² AC-coupling ensures AV_{DD}/2 bias.

³ Guaranteed by design. Sample tested to ensure compliance.

⁴ The synthesizer phase noise floor is estimated by measuring the in-band phase noise at the output of the VCO and subtracting 20 log(N) (where N is the N divider value) and 10 log(F_{PFD}). PN_{SYNTH} = PN_{TOT} - 10 log(F_{PFD}) - 20 log(N).

⁵ The PLL phase noise is composed of 1/f (flicker) noise plus the normalized PLL noise floor. The formula for calculating the 1/f noise contribution at an RF frequency, F_{RF}, and at a frequency offset f is given by PN = PN_{1/f} + 10 log(10 kHz/f) + 20 log(F_{RF}/1 GHz). Both the normalized phase noise floor and flicker noise are modeled in ADIsimPLL.

⁶ The synthesizer phase noise floor is estimated by measuring the in-band phase noise at the output of the VCO and subtracting 20logN (where N is the N divider value).

⁷ The phase noise is measured with the EV-ADF41575D1Z and the Agilent E5052A phase noise system.

⁸ f_{REFIN} = 100 MHz; f_{PFD} = 25 MHz; offset frequency = 2 kHz; RF_{OUT} = 5800.25 MHz; N = 232; loop bandwidth = 20 kHz.

TIMING SPECIFICATIONS

$AV_{DD} = DV_{DD} = 2.7\text{ V to }3.3\text{ V}$; $V_P = AV_{DD}$ to 5.5 V ; $AGND = DGND = 0\text{ V}$; $T_A = T_{MIN}$ to T_{MAX} , unless otherwise noted; dBm referred to $50\ \Omega$.

Table 2.

| Parameter | Limit at T_{MIN} to T_{MAX} (B Version) | Unit | Test Conditions/Comments |
|-----------|---|--------|--------------------------|
| t_1 | 20 | ns min | LE setup time |
| t_2 | 10 | ns min | Data to clock setup time |
| t_3 | 10 | ns min | Data to clock hold time |
| t_4 | 25 | ns min | Clock high duration |
| t_5 | 25 | ns min | Clock low duration |
| t_6 | 10 | ns min | Clock to LE setup time |
| t_7 | 20 | ns min | LE pulse width |

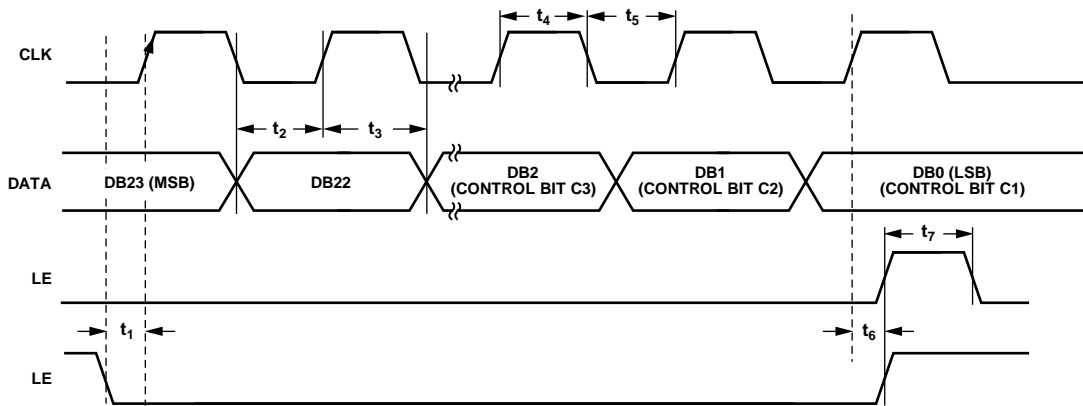

Figure 2. Timing Diagram

05874-002

ABSOLUTE MAXIMUM RATINGS

$T_A = 25^\circ\text{C}$, GND = AGND = DGND = 0 V, $V_{DD} = AV_{DD} = DV_{DD}$, unless otherwise noted.

Table 3.

| Parameter | Rating |
|--------------------------------------|----------------------------|
| AV_{DD}/DV_{DD} to AGND/DGND | -0.3 V to +4 V |
| AV_{DD} to DV_{DD} | -0.3 V to +0.3 V |
| V_p to AGND/DGND | -0.3 V to +5.8 V |
| V_p to AV_{DD}/DV_{DD} | -0.3 V to +5.8 V |
| Digital I/O Voltage to AGND/DGND | -0.3 V to $V_{DD} + 0.3$ V |
| Analog I/O Voltage to AGND/DGND | -0.3 V to $V_{DD} + 0.3$ V |
| REF_{IN} , RF_{INx} to AGND/DGND | -0.3 V to $V_{DD} + 0.3$ V |
| Operating Temperature Range | |
| Industrial (B Version) | -40°C to +85°C |
| Storage Temperature Range | -65°C to +125°C |
| Maximum Junction Temperature | 150°C |
| Reflow Soldering | |
| Peak Temperature | 260°C |
| Time at Peak Temperature | 40 sec |

Stresses above those listed under Absolute Maximum Ratings may cause permanent damage to the device. This is a stress rating only; functional operation of the device at these or any other conditions above those indicated in the operational section of this specification is not implied. Exposure to absolute maximum rating conditions for extended periods may affect device reliability.

THERMAL RESISTANCE

θ_{JA} is specified for the worst-case conditions, that is, a device soldered in a circuit board for surface-mount packages.

Table 4. Thermal Resistance

| Package Type | θ_{JA} | Unit |
|-------------------------|---------------|------|
| TSSOP | 112 | °C/W |
| LFCSP (Paddle Soldered) | 30.4 | °C/W |

ESD CAUTION



ESD (electrostatic discharge) sensitive device. Charged devices and circuit boards can discharge without detection. Although this product features patented or proprietary protection circuitry, damage may occur on devices subjected to high energy ESD. Therefore, proper ESD precautions should be taken to avoid performance degradation or loss of functionality.

PIN CONFIGURATIONS AND FUNCTION DESCRIPTIONS

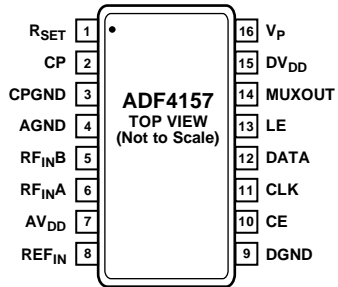
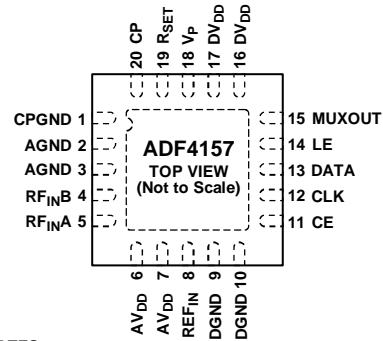

Figure 3. TSSOP Pin Configuration



NOTES
 1. IT IS RECOMMENDED THAT THE EXPOSED PAD BE THERMALLY CONNECTED TO A COPPER PLANE FOR ENHANCED THERMAL PERFORMANCE. THIS PAD SHOULD BE CONNECTED TO AGND.

Figure 4. LFCSP Pin Configuration

Table 5. Pin Function Descriptions

| TSSOP Pin No. | LFCSP Pin No. | Mnemonic | Description |
|---------------|---------------|-------------------|---|
| 1 | 19 | R _{SET} | Connecting a resistor between this pin and ground sets the maximum charge pump output current. The relationship between I _{CP} and R _{SET} is $I_{CPMAX} = \frac{25.5}{R_{SET}}$ where: R _{SET} = 5.1 kΩ. I _{CPMAX} = 5 mA. |
| 2 | 20 | CP | Charge Pump Output. When enabled, this pin provides ±I _{CP} to the external loop filter, which, in turn, drives the external VCO. |
| 3 | 1 | CPGND | Charge Pump Ground. This is the ground return path for the charge pump. |
| 4 | 2, 3 | AGND | Analog Ground. This is the ground return path of the prescaler. |
| 5 | 4 | RF _{INB} | Complementary Input to the RF Prescaler. This point should be decoupled to the ground plane with a small bypass capacitor, typically 100 pF. |
| 6 | 5 | RF _{INA} | Input to the RF Prescaler. This small-signal input is normally ac-coupled from the VCO. |
| 7 | 6, 7 | AV _{DD} | Positive Power Supply for the RF Section. Decoupling capacitors to the digital ground plane should be placed as close as possible to this pin. AV _{DD} has a value of 3 V ± 10%. AV _{DD} must have the same voltage as DV _{DD} . |
| 8 | 8 | REF _{IN} | Reference Input. This is a CMOS input with a nominal threshold of V _{DD} /2 and an equivalent input resistance of 100 kΩ. This input can be driven from a TTL or CMOS crystal oscillator, or it can be ac-coupled. |
| 9 | 9, 10 | DGND | Digital Ground. |
| 10 | 11 | CE | Chip Enable. A logic low on this pin powers down the device and puts the charge pump output into three-state mode. |
| 11 | 12 | CLK | Serial Clock Input. This serial clock is used to clock in the serial data to the registers. The data is latched into the input shift register on the CLK rising edge. This input is a high impedance CMOS input. |
| 12 | 13 | DATA | Serial Data Input. The serial data is loaded MSB first with the three LSBs being the control bits. This input is a high impedance CMOS input. |
| 13 | 14 | LE | Load Enable, CMOS Input. When LE is high, the data stored in the input shift register is loaded into one of the five latches, with the latch selected using the control bits. |
| 14 | 15 | MUXOUT | This multiplexer output allows the lock detect, the scaled RF, or the scaled reference frequency to be accessed externally. |

| TSSOP Pin No. | LFCSP Pin No. | Mnemonic | Description |
|---------------|---------------|--------------------|--|
| 15 | 16, 17 | DV _{DD} | Positive Power Supply for the Digital Section. Decoupling capacitors to the digital ground plane should be placed as close as possible to this pin. DV _{DD} has a value of 3 V ± 10%. DV _{DD} must have the same voltage as AV _{DD} . |
| 16 | 18 | V _p | Charge Pump Power Supply. This should be greater than or equal to V _{DD} . In systems where V _{DD} is 3 V, it can be set to 5.5 V and used to drive a VCO with a tuning range of up to 5.5 V. |
| N/A | 21 (EPAD) | Exposed Pad (EPAD) | It is recommended that the exposed pad be thermally connected to a copper plane for enhanced thermal performance. The pad should be connected to AGND. |

TYPICAL PERFORMANCE CHARACTERISTICS

PF_D = 25 MHz, loop bandwidth = 20 kHz, reference = 100 MHz, I_{CP} = 313 μA, phase noise measurements taken on the Agilent E5052A phase noise system.

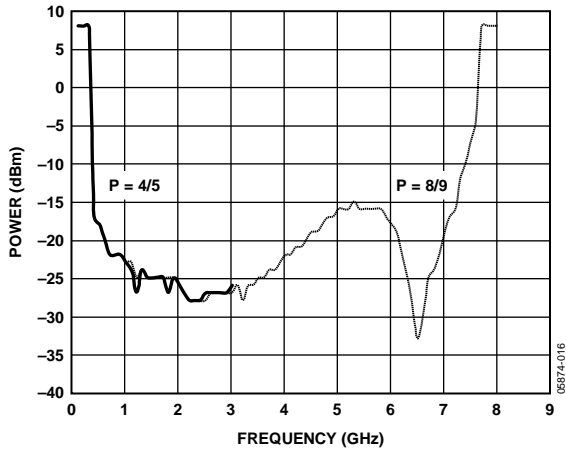

Figure 5. RF Input Sensitivity

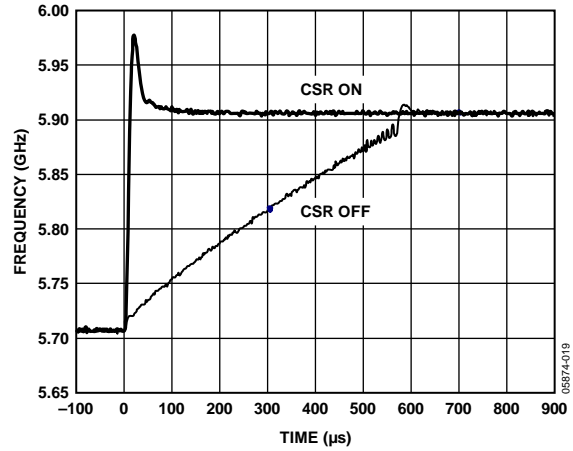

Figure 8. Lock Time for 200 MHz Jump from 5705 MHz to 5905 MHz with CSR On and Off

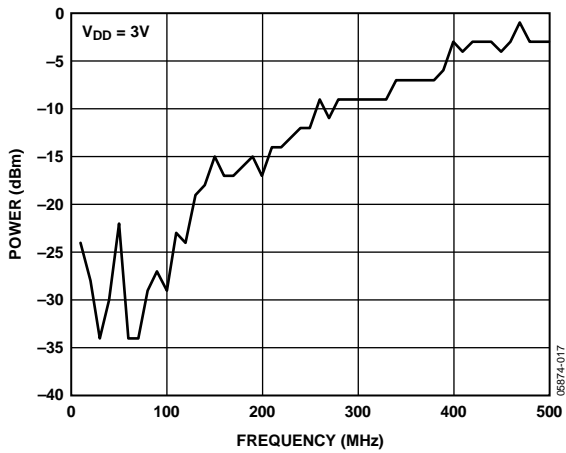

Figure 6. Reference Input Sensitivity

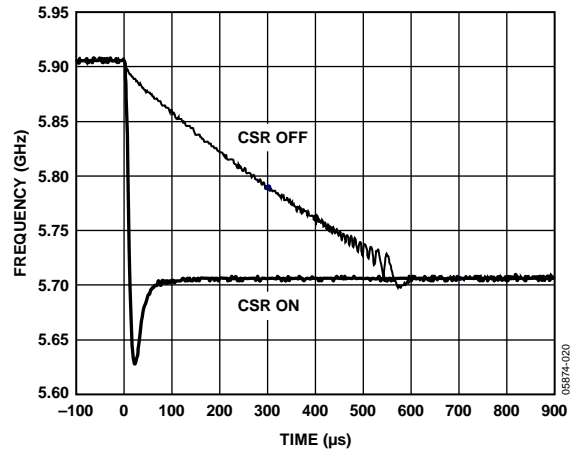

Figure 9. Lock Time for 200 MHz Jump from 5905 MHz to 5705 MHz with CSR On and Off

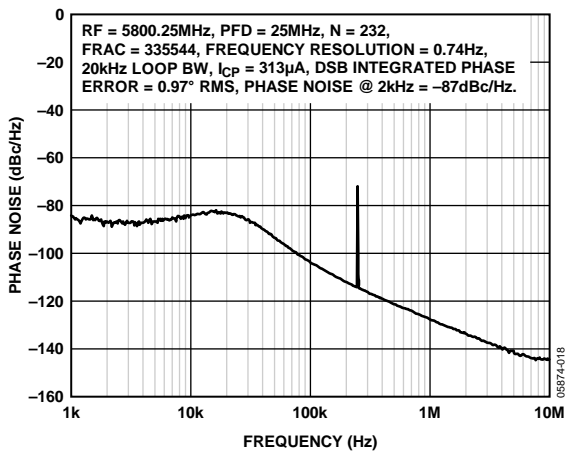

Figure 7. Phase Noise and Spurs
(Note that the 250 kHz spur is an integer boundary spur; see the Spur Mechanisms section for more information.)

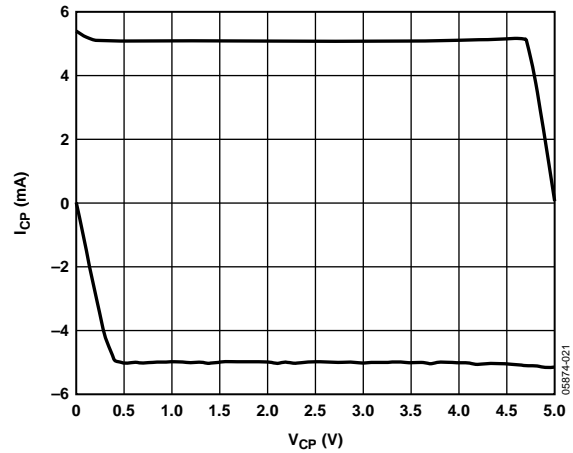

Figure 10. Charge Pump Output Characteristics, Pump Up and Pump Down

CIRCUIT DESCRIPTION

REFERENCE INPUT SECTION

The reference input stage is shown in Figure 11. SW1 and SW2 are normally closed switches. SW3 is normally open. When power-down is initiated, SW3 is closed and SW1 and SW2 are open. This ensures that there is no loading of the REF_{IN} pin on power-down.

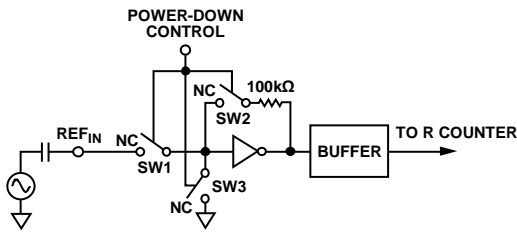

Figure 11. Reference Input Stage

RF INPUT STAGE

The RF input stage is shown in Figure 12. It is followed by a two-stage limiting amplifier to generate the current mode logic (CML) clock levels needed for the prescaler.

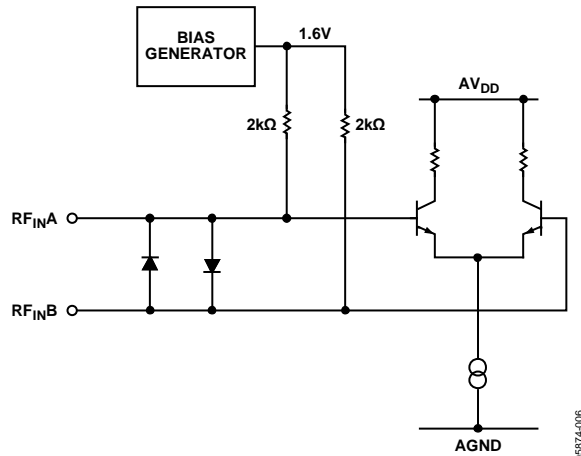

Figure 12. RF Input Stage

RF INT DIVIDER

The RF INT counter allows a division ratio in the PLL feedback counter. Division ratios from 23 to 4095 are allowed.

25-BIT FIXED MODULUS

The ADF4157 has a 25-bit fixed modulus. This allows output frequencies to be spaced with a resolution of

$$f_{RES} = f_{PFD} / 2^{25}$$

where f_{PFD} is the frequency of the phase frequency detector (PFD). For example, with a PFD frequency of 10 MHz, frequency steps of 0.298 Hz are possible.

INT, FRAC, AND R RELATIONSHIP

The INT and FRAC values, in conjunction with the R counter, make it possible to generate output frequencies that are spaced by fractions of the phase frequency detector (PFD). See the RF Synthesizer: A Worked Example section for more information. The RF VCO frequency (RF_{OUT}) equation is

$$RF_{OUT} = f_{PFD} \times (INT + (FRAC/2^{25})) \tag{1}$$

where:

RF_{OUT} is the output frequency of the external voltage controlled oscillator (VCO).

INT is the preset divide ratio of the binary 12-bit counter (23 to 4095).

FRAC is the numerator of the fractional division (0 to $2^{25} - 1$).

$$f_{PFD} = REF_{IN} \times [(1 + D)/(R \times (1 + T))] \tag{2}$$

where:

REF_{IN} is the reference input frequency.

D is the REF_{IN} doubler bit.

R is the preset divide ratio of the binary 5-bit programmable reference counter (1 to 32).

T is the REF_{IN} divide-by-2 bit (0 or 1).

RF R COUNTER

The 5-bit RF R counter allows the input reference frequency (REF_{IN}) to be divided down to produce the reference clock to the PFD. Division ratios from 1 to 32 are allowed.

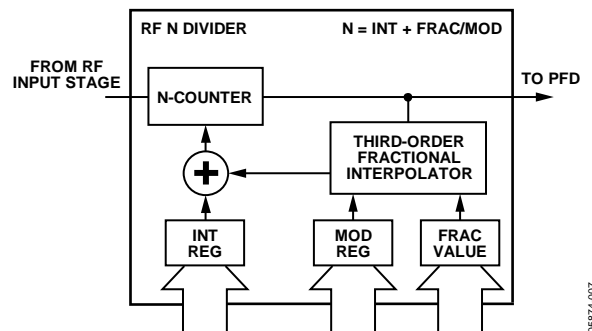

Figure 13. RF N Divider

PHASE FREQUENCY DETECTOR (PFD) AND CHARGE PUMP

The PFD takes inputs from the R counter and the N counter and produces an output proportional to the phase and frequency difference between them. Figure 14 is a simplified schematic of the phase frequency detector. The PFD includes a fixed delay element that sets the width of the antibacklash pulse, which is typically 3 ns. This pulse ensures that there is no dead zone in the PFD transfer function and gives a consistent reference spur level.

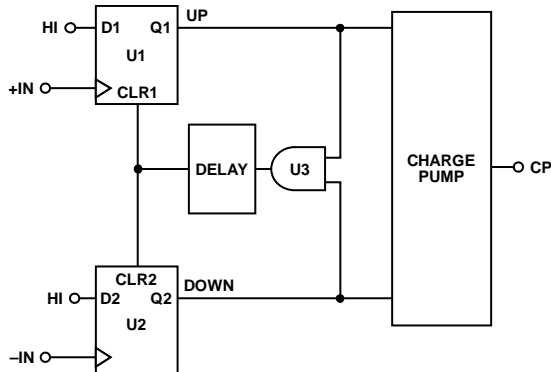

Figure 14. PFD Simplified Schematic

05874-008

MUXOUT AND LOCK DETECT

The output multiplexer on the ADF4157 allows the user to access various internal points on the chip. The state of MUXOUT is controlled by M4, M3, M2, and M1 (see Figure 17). Figure 15 shows the MUXOUT section in block diagram form.

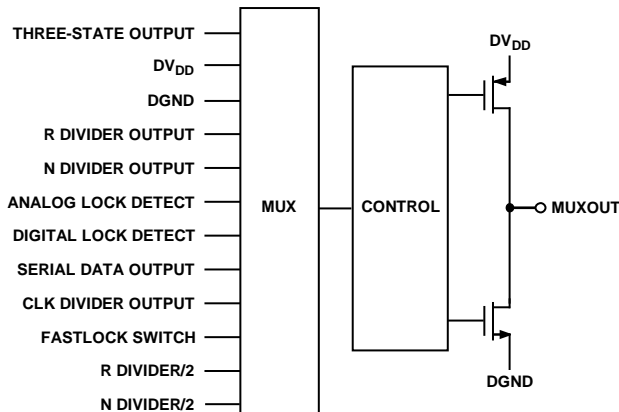

Figure 15. MUXOUT Schematic

05874-009

INPUT SHIFT REGISTER

The ADF4157 digital section includes a 5-bit RF R counter, a 12-bit RF N counter, and a 25-bit FRAC counter. Data is clocked into the 32-bit input shift register on each rising edge of CLK. The data is clocked in MSB first. Data is transferred from the input shift register to one of five latches on the rising edge of LE. The destination latch is determined by the state of the three control bits (C3, C2, and C1) in the input shift register. These are the three LSBs, DB2, DB1, and DB0, as shown in Figure 2. The truth table for these bits is shown in Table 6. Figure 16 shows a summary of how the latches are programmed.

PROGRAM MODES

Table 6 and Figure 16 through Figure 21 show how to set up the program modes in the ADF4157.

Several settings in the ADF4157 are double-buffered. These include the LSB FRAC value, R counter value, reference doubler, and current setting. This means that two events have to occur before the part uses a new value of any of the double-buffered settings. First, the new value is latched into the device by writing to the appropriate register. Second, a new write must be performed on Register 0, R0.

For example, updating the fractional value can involve a write to the 13 LSB bits in R1 and the 12 MSB bits in R0. R1 should be written to first, followed by the write to R0. The frequency change begins after the write to R0. Double buffering ensures that the bits written to in R1 do not take effect until after the write to R0.

Table 6. C3, C2, and C1 Truth Table

| Control Bits | | | Register |
|--------------|----|----|-----------------|
| C3 | C2 | C1 | |
| 0 | 0 | 0 | Register 0 (R0) |
| 0 | 0 | 1 | Register 1 (R1) |
| 0 | 1 | 0 | Register 2 (R2) |
| 0 | 1 | 1 | Register 3 (R3) |
| 1 | 0 | 0 | Register 4 (R4) |

REGISTER MAPS

FRAC/INT REGISTER (R0)

| RESERVED | MUXOUT CONTROL | | | | | 12-BIT INTEGER VALUE (INT) | | | | | | | | | | | 12-BIT MSB FRACTIONAL VALUE (FRAC) | | | | | | | | | | CONTROL BITS | | | | |
|----------|----------------|------|------|------|------|----------------------------|------|------|------|------|------|------|------|------|------|------|------------------------------------|------|------|------|------|-----|-----|-----|-----|-----|--------------|-----|-------|-------|-------|
| DB31 | DB30 | DB29 | DB28 | DB27 | DB26 | DB25 | DB24 | DB23 | DB22 | DB21 | DB20 | DB19 | DB18 | DB17 | DB16 | DB15 | DB14 | DB13 | DB12 | DB11 | DB10 | DB9 | DB8 | DB7 | DB6 | DB5 | DB4 | DB3 | DB2 | DB1 | DB0 |
| 0 | M4 | M3 | M2 | M1 | N12 | N11 | N10 | N9 | N8 | N7 | N6 | N5 | N4 | N3 | N2 | N1 | F25 | F24 | F23 | F22 | F21 | F20 | F19 | F18 | F17 | F16 | F15 | F14 | C3(0) | C2(0) | C1(0) |

LSB FRAC REGISTER (R1)

| RESERVED | | | | | 13-BIT LSB FRACTIONAL VALUE (FRAC) (DBB) | | | | | | | | | | | | | RESERVED | | | | | | | | | | CONTROL BITS | | | | | |
|----------|------|------|------|------|--|------|------|------|------|------|------|------|------|------|------|------|------|----------|------|------|------|-----|-----|-----|-----|-----|-----|--------------|-----|-----|-------|-------|-------|
| DB31 | DB30 | DB29 | DB28 | DB27 | DB26 | DB25 | DB24 | DB23 | DB22 | DB21 | DB20 | DB19 | DB18 | DB17 | DB16 | DB15 | DB14 | DB13 | DB12 | DB11 | DB10 | DB9 | DB8 | DB7 | DB6 | DB5 | DB4 | DB3 | DB2 | DB1 | DB0 | | |
| 0 | 0 | 0 | 0 | F13 | F12 | F11 | F10 | F9 | F8 | F7 | F6 | F5 | F4 | F3 | F2 | F1 | 0 | 0 | 0 | 0 | 0 | 0 | 0 | 0 | 0 | 0 | 0 | 0 | 0 | 0 | C3(0) | C2(0) | C1(0) |

R DIVIDER REGISTER (R2)

| RESERVED | RESERVED | CSR EN | DBB CURRENT SETTING | | | | | RESERVED | PRESCALER | RDIV2 DBB | REFERENCE DOUBLER DBB | DBB 5-BIT R COUNTER | | | | | RESERVED | | | | | | | | | | CONTROL BITS | | | | | | |
|----------|----------|--------|------------------------|------|------|------|------|----------|-----------|-----------|-----------------------|------------------------|------|------|------|------|----------|------|------|------|------|-----|-----|-----|-----|-----|--------------|-----|-----|-----|-------|-------|-------|
| DB31 | DB30 | DB29 | DB28 | DB27 | DB26 | DB25 | DB24 | DB23 | DB22 | DB21 | DB20 | DB19 | DB18 | DB17 | DB16 | DB15 | DB14 | DB13 | DB12 | DB11 | DB10 | DB9 | DB8 | DB7 | DB6 | DB5 | DB4 | DB3 | DB2 | DB1 | DB0 | | |
| 0 | 0 | 0 | C1 | CP14 | CP13 | CP12 | CP11 | 0 | P1 | U2 | U1 | R5 | R4 | R3 | R2 | R1 | 0 | 0 | 0 | 0 | 0 | 0 | 0 | 0 | 0 | 0 | 0 | 0 | 0 | 0 | C3(0) | C2(1) | C1(0) |

FUNCTION REGISTER (R3)

| RESERVED | | | | | | | | | | | | | | | | | SD RESET | RESERVED | | | | | | | LDP | PD POLARITY | PD | CP THREE-STATE COUNTER RESET | CONTROL BITS | | | |
|----------|------|------|------|------|------|------|------|------|------|------|------|------|------|------|------|------|----------|----------|------|------|------|-----|-----|-----|-----|-------------|-----|------------------------------|--------------|-------|-------|-------|
| DB31 | DB30 | DB29 | DB28 | DB27 | DB26 | DB25 | DB24 | DB23 | DB22 | DB21 | DB20 | DB19 | DB18 | DB17 | DB16 | DB15 | DB14 | DB13 | DB12 | DB11 | DB10 | DB9 | DB8 | DB7 | DB6 | DB5 | DB4 | DB3 | DB2 | DB1 | DB0 | |
| 0 | 0 | 0 | 0 | 0 | 0 | 0 | 0 | 0 | 0 | 0 | 0 | 0 | 0 | 0 | 0 | 0 | U12 | 0 | 0 | 0 | 0 | 0 | 0 | 0 | U11 | U10 | U9 | U8 | U7 | C3(0) | C2(1) | C1(1) |

TEST REGISTER (R4)

| RESERVED | | | | | | | | | | NEG BLEED CURRENT | RESERVED | CLK DIV MODE | 12-BIT CLOCK DIVIDER VALUE | | | | | | | | | | RESERVED | | | | | CONTROL BITS | | | | |
|----------|------|------|------|------|------|------|------|------|------|-------------------|----------|--------------|----------------------------|------|------|------|------|------|------|------|------|-----|----------|-----|-----|-----|-----|--------------|-----|-------|-------|-------|
| DB31 | DB30 | DB29 | DB28 | DB27 | DB26 | DB25 | DB24 | DB23 | DB22 | DB21 | DB20 | DB19 | DB18 | DB17 | DB16 | DB15 | DB14 | DB13 | DB12 | DB11 | DB10 | DB9 | DB8 | DB7 | DB6 | DB5 | DB4 | DB3 | DB2 | DB1 | DB0 | |
| 0 | 0 | 0 | 0 | 0 | 0 | 0 | NB2 | NB1 | 0 | 0 | C2 | C1 | D12 | D11 | D10 | D9 | D8 | D7 | D6 | D5 | D4 | D3 | D2 | D1 | 0 | 0 | 0 | 0 | 0 | C3(1) | C2(0) | C1(0) |

NOTES
1. DBB = DOUBLE BUFFERED BIT(S).

Figure 16. Register Summary

05874-010

FRAC/INT REGISTER (R0) MAP

With R0[2:0] set to 000, the on-chip FRAC/INT register is programmed as shown in Figure 17.

Reserved Bit

The reserved bit should be set to 0 for normal operation.

MUXOUT

The on-chip multiplexer is controlled by Bits DB[30:27] on the ADF4157. See Figure 17 for the truth table.

12-Bit INT Value

These 12 bits control what is loaded as the INT value. This is used to determine the overall feedback division factor. It is used

in Equation 1. See the INT, FRAC, and R Relationship section for more information.

12-Bit MSB FRAC Value

These 12 bits, along with Bits DB[27:15] in the LSB FRAC register (R1), control what is loaded as the FRAC value into the fractional interpolator. This is part of what determines the overall feedback division factor. It is also used in Equation 1. These 12 bits are the most significant bits (MSB) of the 25-bit FRAC value, and Bits DB[27:15] in the LSB FRAC register (R1) are the least significant bits (LSB). See the RF Synthesizer: A Worked Example section for more information.

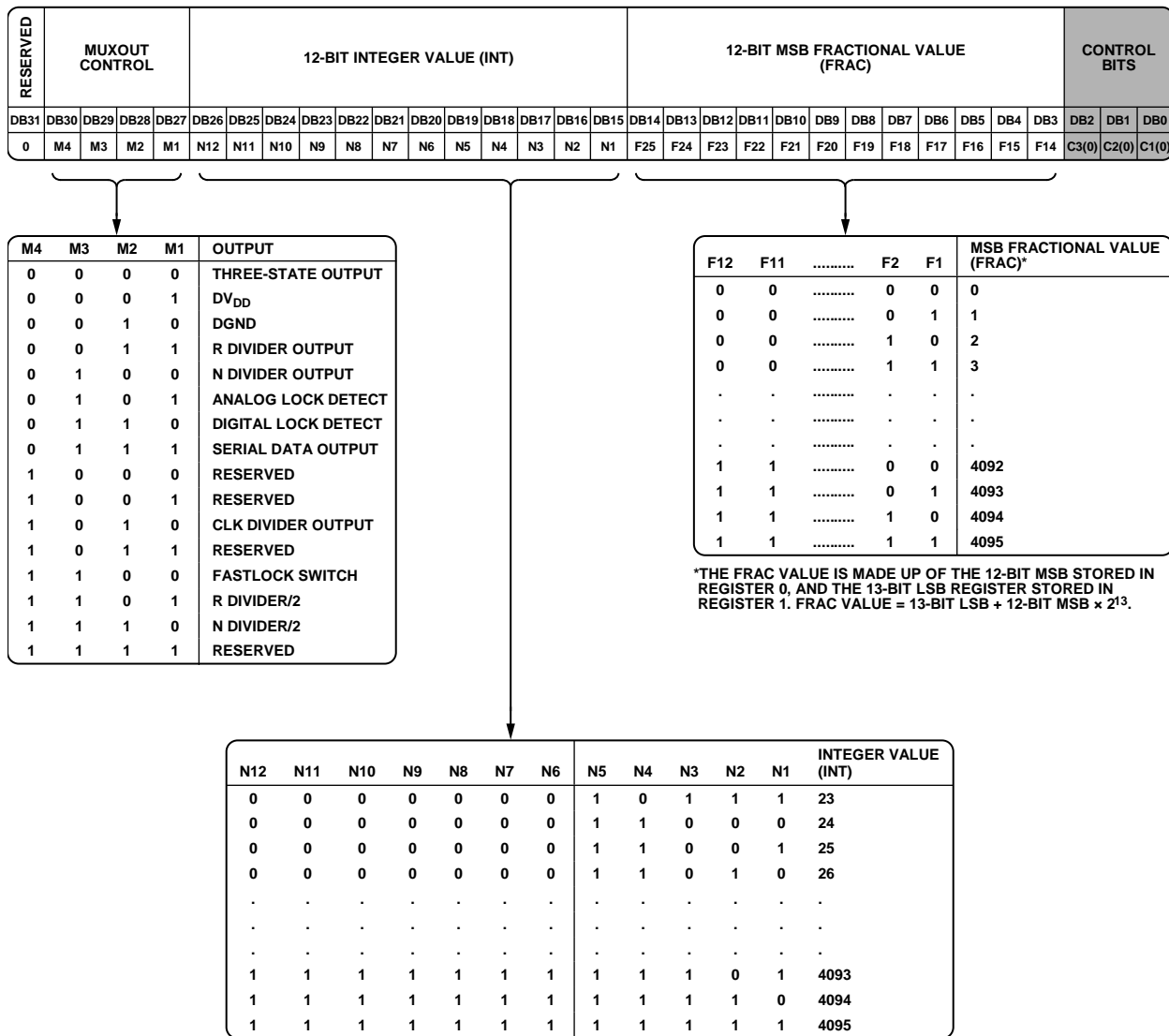

Figure 17. FRAC/INT Register (R0) Map

08974-011

LSB FRAC REGISTER (R1) MAP

With R1[2:0] set to 001, the on-chip LSB FRAC register is programmed as shown in Figure 18.

13-Bit LSB FRAC Value

These 13 bits, along with Bits DB[14:3] in the INT/FRAC register (R0), control what is loaded as the FRAC value into the fractional interpolator. This is part of what determines the overall feedback division factor. It is also used in Equation 1.

These 13 bits are the least significant bits of the 25-bit FRAC value, and Bits DB[14:3] in the INT/FRAC register are the most significant bits. See the RF Synthesizer: A Worked Example section for more information.

Reserved Bits

All reserved bits should be set to 0 for normal operation.

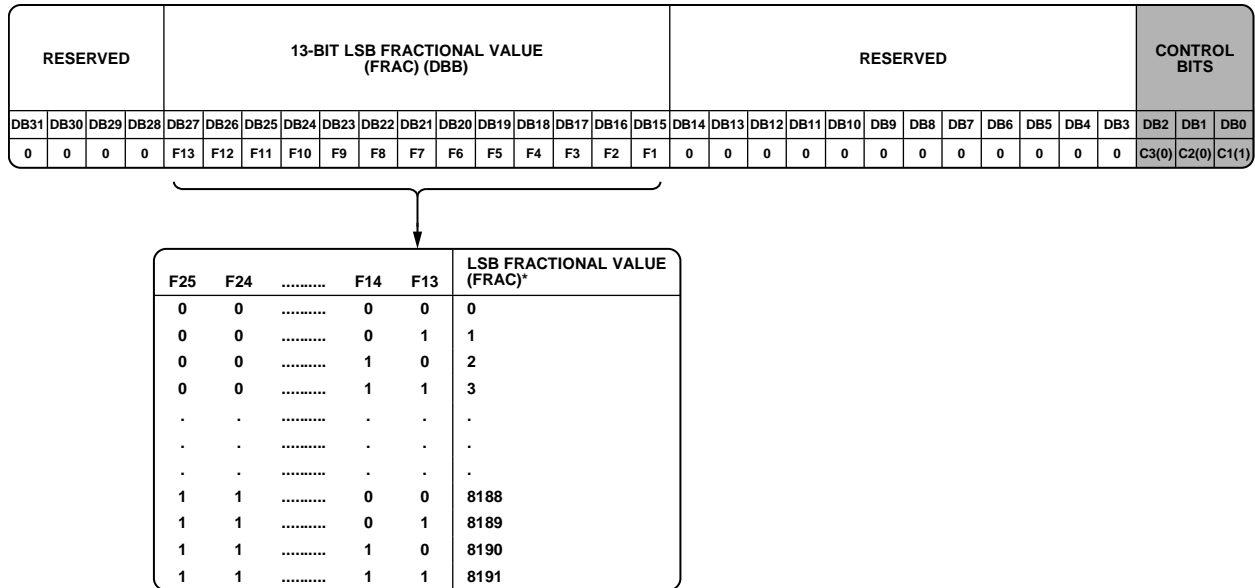

*THE FRAC VALUE IS MADE UP OF THE 12-BIT MSB STORED IN REGISTER 0, AND THE 13-BIT LSB REGISTER STORED IN REGISTER 1. FRAC VALUE = 13-BIT LSB + 12-BIT MSB x 2¹³.

Figure 18. LSB FRAC Register (R1) Map

05874-01Z

R DIVIDER REGISTER (R2) MAP

With R2[2:0] set to 010, the on-chip R divider register is programmed as shown in Figure 19.

CSR Enable

Setting this bit to 1 enables cycle slip reduction. This is a method for improving lock times. Note that the signal at the PFD must have a 50% duty cycle for cycle slip reduction to work. In addition, the charge pump current setting must be set to a minimum. See the Cycle Slip Reduction for Faster Lock Times section for more information.

Note also that the cycle slip reduction feature can only be operated when the phase detector polarity setting is positive (DB6 in Register 3). It cannot be used if the phase detector polarity is set to negative.

Charge Pump Current Setting

Bits DB[27:24] set the charge pump current setting. This should be set to the charge pump current that the loop filter is designed with (see Figure 19).

Prescaler (P/P + 1)

The dual-modulus prescaler ($P/P + 1$), along with INT, FRAC, and MOD, determine the overall division ratio from RF_{INX} to the PFD input.

Operating at CML levels, it takes the clock from the RF input stage and divides it down for the counters. It is based on a synchronous 4/5 core. When set to 4/5, the maximum RF frequency allowed is 3 GHz. Therefore, when operating the ADF4157 above 3 GHz, the prescaler must be set to 8/9. The prescaler limits the INT value.

With $P = 4/5$, $N_{MIN} = 23$.

With $P = 8/9$, $N_{MIN} = 75$.

RDIV2

Setting this bit to 1 inserts a divide-by-2 toggle flip-flop between the R counter and the PFD. This can be used to provide a 50% duty cycle signal at the PFD for use with cycle slip reduction.

Reference Doubler

Setting DB[20] to 0 feeds the REF_{IN} signal directly to the 5-bit RF R counter, disabling the doubler. Setting this bit to 1 multiplies the REF_{IN} frequency by a factor of 2 before feeding into the 5-bit R counter. When the doubler is disabled, the REF_{IN} falling edge is the active edge at the PFD input to the fractional synthesizer. When the doubler is enabled, both the rising edge and falling edge of REF_{IN} become active edges at the PFD input.

The maximum allowed REF_{IN} frequency when the doubler is enabled is 30 MHz.

5-Bit R Counter

The 5-bit R counter allows the input reference frequency (REF_{IN}) to be divided down to produce the reference clock to the phase frequency detector (PFD). Division ratios from 1 to 32 are allowed.

Reserved Bits

All reserved bits should be set to 0 for normal operation.

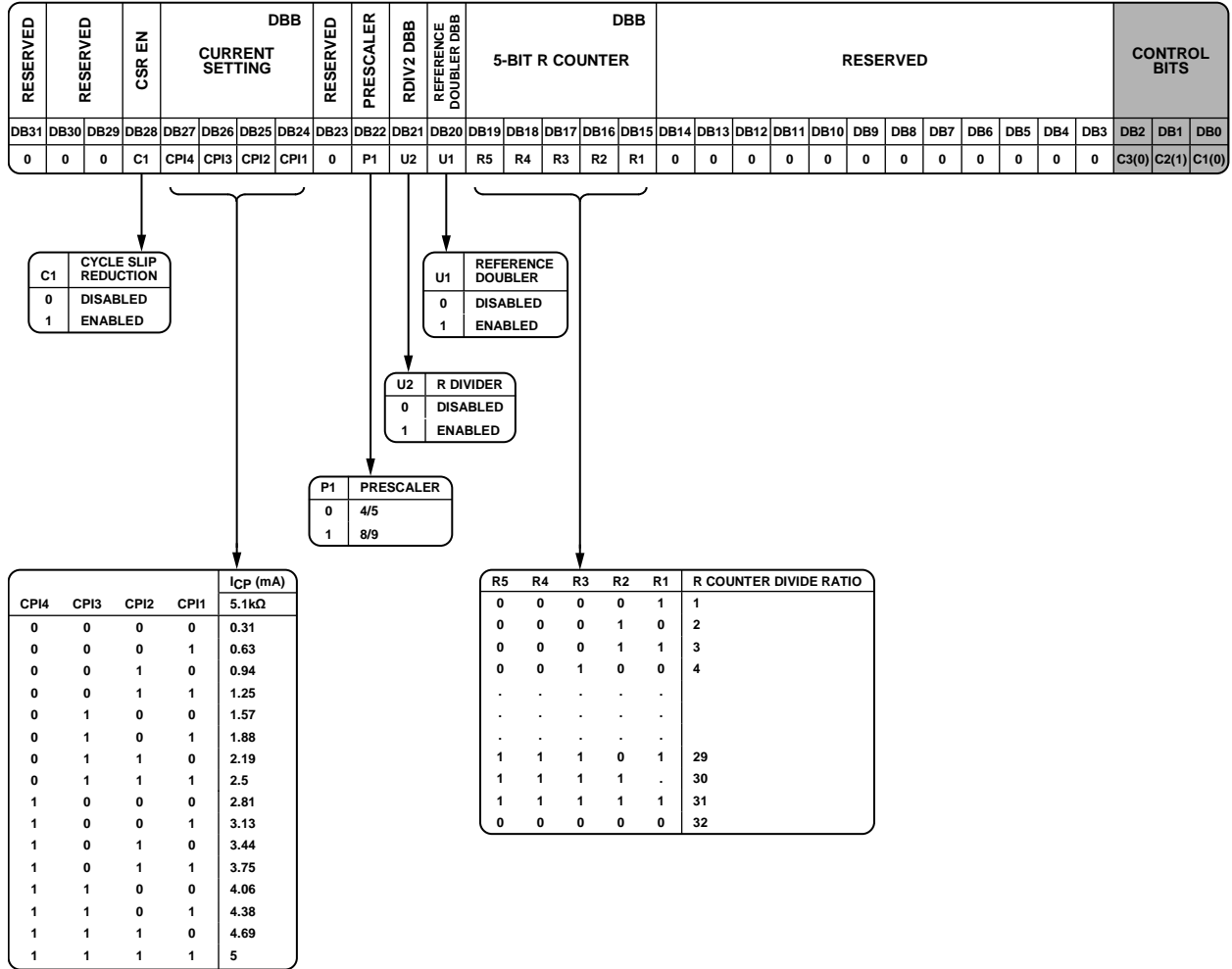

Figure 19. R Divider Register (R2) Map

05874-013

FUNCTION REGISTER (R3) MAP

With R3[2:0] set to 011, the on-chip function register is programmed as shown in Figure 20.

Reserved Bits

All reserved bits should be set to 0 for normal operation.

Σ - Δ Reset

For most applications, DB14 should be set to 0. When DB14 is set to 0, the Σ - Δ modulator is reset on each write to Register 0. If it is not required that the Σ - Δ modulator be reset on each Register 0 write, this bit should be set to 1.

Lock Detect Precision (LDP)

When DB[7] is programmed to 0, 24 consecutive PFD cycles of 15 ns must occur before digital lock detect is set. When this bit is programmed to 1, 40 consecutive reference cycles of 15 ns must occur before digital lock detect is set.

Phase Detector Polarity

DB[6] sets the phase detector polarity. When the VCO characteristics are positive, this should be set to 1. When they are negative, it should be set to 0.

RF Power-Down

DB[5] provides the programmable power-down mode. Setting this bit to 1 performs a power-down. Setting this bit to 0 returns the synthesizer to normal operation. While in software power-down mode, the part retains all information in its registers. Only when supplies are removed are the register contents lost.

When a power-down is activated, the following events occur:

- All active dc current paths are removed.
- The synthesizer counters are forced to their load state conditions.
- The charge pump is forced into three-state mode.
- The digital lock detect circuitry is reset.
- The RF_{IN,x} input is debiased.
- The input shift register remains active and capable of loading and latching data.

RF Charge Pump Three-State

DB[4] puts the charge pump into three-state mode when programmed to 1. It should be set to 0 for normal operation.

RF Counter Reset

DB[3] is the RF counter reset bit for the ADF4157. When this is 1, the RF synthesizer counters are held in reset. For normal operation, this bit should be 0.

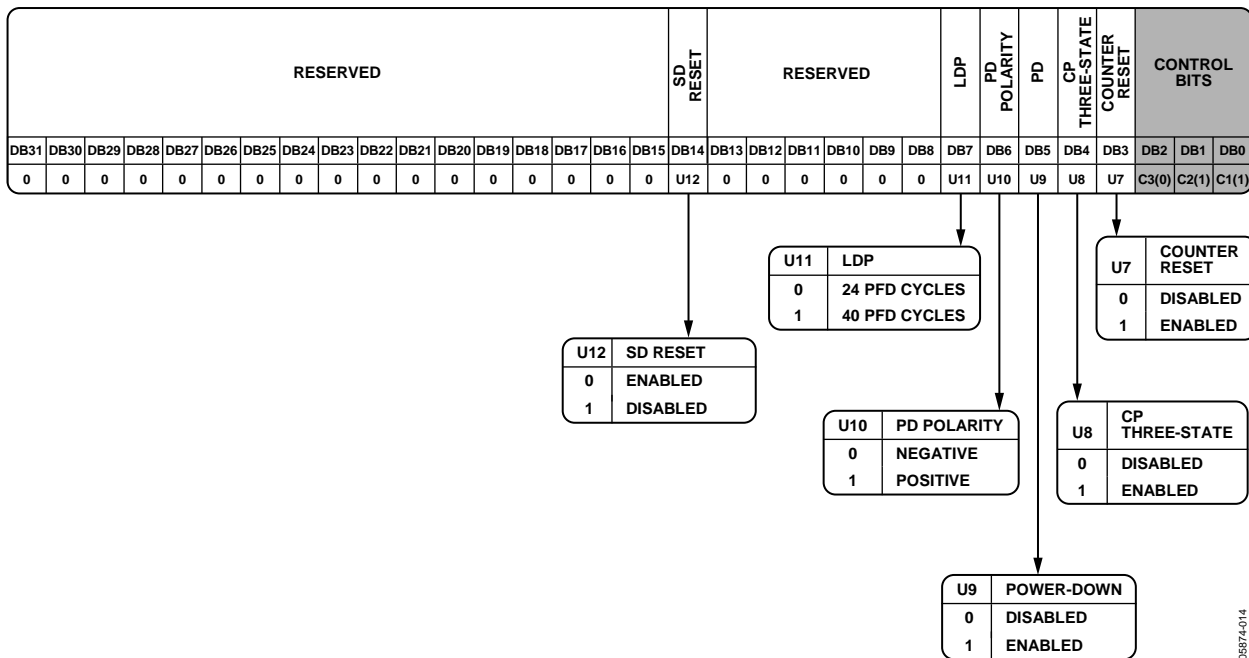

Figure 20. Function Register (R3) Map

06974-014

TEST REGISTER (R4) MAP

With R4[2:0] set to 100, the on-chip test register (R4) is programmed as shown in Figure 21.

Negative Bleed Current

Setting Bits DB[24:23] to 11 turns on the constant negative bleed current. This ensures that the charge pump operates out of the dead zone. Thus the phase noise is not degraded and the level of spurs is lower. Enabling constant negative bleed current is particularly important on channels close to multiple PFD frequencies.

CLK Divider Mode

Setting Bits DB[20:19] to 01 enables switched R fastlock.

12-Bit Clock Divider Value

Bits DB[18:7] are used to program the clock divider, which determines for how long the loop remains in wideband mode while the switched R fastlock technique is used.

Reserved Bits

All reserved bits should be set to 0 for normal operation.

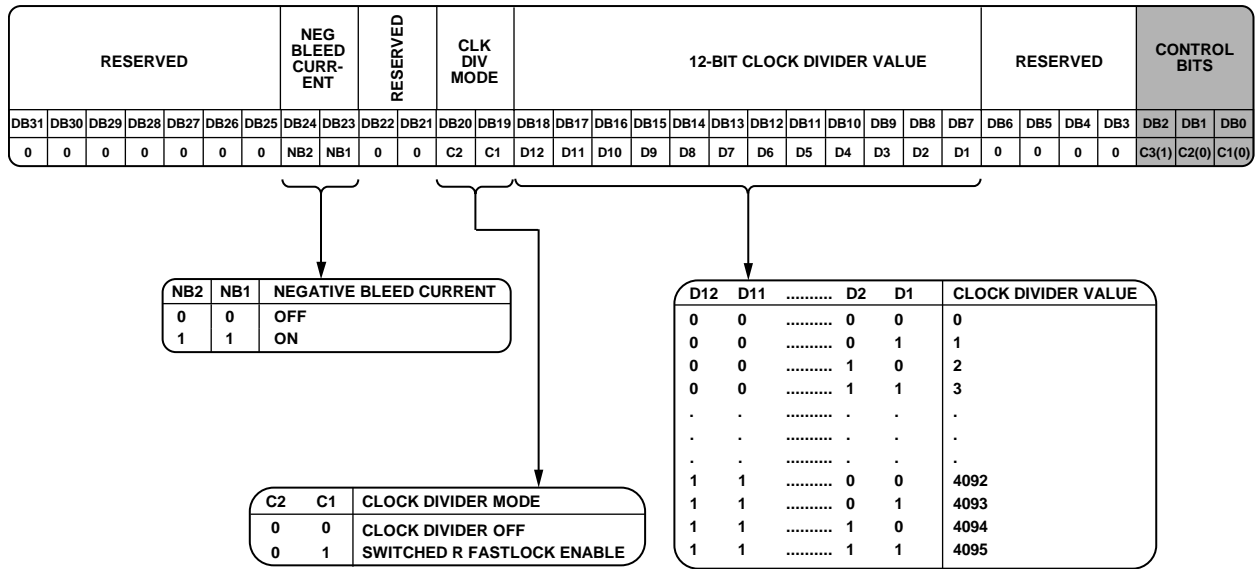

Figure 21. Test Register (R4) Map

06874-015

APPLICATIONS INFORMATION

INITIALIZATION SEQUENCE

After powering up the part, this programming sequence must be followed:

1. Test register (R4)
2. Function register (R3)
3. R divider register (R2)
4. LSB FRAC register (R1)
5. FRAC/INT register (R0)

RF SYNTHESIZER: A WORKED EXAMPLE

The following equation governs how the synthesizer should be programmed:

$$RF_{OUT} = [N + (FRAC/2^{25})] \times [f_{PFD}] \quad (3)$$

where:

RF_{OUT} is the RF frequency output.

N is the integer division factor.

$FRAC$ is the fractionality.

$$f_{PFD} = REF_{IN} \times [(1 + D)/(R \times (1 + T))] \quad (4)$$

where:

REF_{IN} is the reference frequency input.

D is the RF REF_{IN} doubler bit.

R is the RF reference division factor.

T is the reference divide-by-2 bit (0 or 1).

For example, in a system where a 5.8002 GHz RF frequency output (RF_{OUT}) is required and a 10 MHz reference frequency input (REF_{IN}) is available, the frequency resolution is

$$\begin{aligned} f_{RES} &= REF_{IN}/2^{25} \\ f_{RES} &= 10 \text{ MHz}/2^{25} = 0.298 \text{ Hz} \end{aligned}$$

From Equation 4,

$$\begin{aligned} f_{PFD} &= [10 \text{ MHz} \times (1 + 0)/1] = 10 \text{ MHz} \\ 5.8002 \text{ GHz} &= 10 \text{ MHz} \times (N + FRAC/2^{25}) \end{aligned}$$

Calculating N and $FRAC$ values,

$$\begin{aligned} N &= \text{int}(RF_{OUT}/f_{PFD}) = 580 \\ FRAC &= F_{MSB} \times 2^{13} + F_{LSB} \\ F_{MSB} &= \text{int}(((RF_{OUT}/f_{PFD}) - N) \times 2^{12}) = 81 \\ F_{LSB} &= \text{int}((((RF_{OUT}/f_{PFD}) - N) \times 2^{12}) - F_{MSB}) \times 2^{13} = 7537 \end{aligned}$$

where:

F_{MSB} is the 12-bit MSB FRAC value in Register R0.

F_{LSB} is the 13-bit LSB FRAC value in Register R1.

$\text{int}()$ makes an integer of the argument in brackets.

REFERENCE DOUBLER AND REFERENCE DIVIDER

The on-chip reference doubler allows the input reference signal to be doubled. This is useful for increasing the PFD comparison frequency. Making the PFD frequency higher improves the noise performance of the system. Doubling the PFD frequency usually improves noise performance by 3 dB. It is important to

note that the PFD cannot be operated above 32 MHz due to a limitation in the speed of the Σ - Δ circuit of the N divider.

CYCLE SLIP REDUCTION FOR FASTER LOCK TIMES

In fastlocking applications, a wide loop filter bandwidth is required for fast frequency acquisition, resulting in increased integrated phase noise and reduced spur attenuation. Using cycle slip reduction, the loop bandwidth can be kept narrow to reduce integrated phase noise and attenuate spurs while still realizing fast lock times.

Cycle Slips

Cycle slips occur in integer- N /fractional- N synthesizers when the loop bandwidth is narrow compared to the PFD frequency. The phase error at the PFD inputs accumulates too fast for the PLL to correct, and the charge pump temporarily pumps in the wrong direction, slowing down the lock time dramatically. The ADF4157 contains a cycle slip reduction circuit to extend the linear range of the PFD, allowing faster lock times without loop filter changes.

When the ADF4157 detects that a cycle slip is about to occur, it turns on an extra charge pump current cell. This outputs a constant current to the loop filter or removes a constant current from the loop filter (depending on whether the VCO tuning voltage needs to increase or decrease to acquire the new frequency). The effect is that the linear range of the PFD is increased. Stability is maintained because the current is constant and is not a pulsed current.

If the phase error increases again to a point where another cycle slip is likely, the ADF4157 turns on another charge pump cell. This continues until the ADF4157 detects that the VCO frequency has exceeded the desired frequency. It then begins to turn off the extra charge pump cells one by one until they are all turned off and the frequency is settled.

Up to seven extra charge pump cells can be turned on. In most applications, it is enough to eliminate cycle slips altogether, giving much faster lock times.

Setting Bit DB28 in the R Divider register (R2) to 1 enables cycle slip reduction. Note that a 45% to 55% duty cycle is needed on the signal at the PFD for CSR to operate correctly. The reference divide-by-2 flip-flop can help to provide a 50% duty cycle at the PFD. For example, if a 100 MHz reference frequency is available, and the user wants to run the PFD at 10 MHz, setting the R divide factor to 10 results in a 10 MHz PFD signal that is not 50% duty cycle. By setting the R divide factor to 5 and enabling the reference divide-by-2 bit, a 50% duty cycle 10 MHz signal can be achieved.

Note that the cycle slip reduction feature can only be operated when the phase detector polarity setting is positive (DB6 in Register 3). It cannot be used if the phase detector polarity is set to negative.

FASTLOCK TIMER AND REGISTER SEQUENCES

If the fastlock mode is used, a timer value needs to be loaded into the PLL to determine the time spent in wide bandwidth mode.

When Bits DB[20:19] in Register 4 (R4) are set to 01 (switched R fastlock enable), the timer value is loaded via the 12-bit clock divider value. To use fastlock, the PLL must be written to in the following sequence:

1. Use the initialization sequence (see the Initialization Sequence section) only once after powering up the part.
2. Load Register 4 (R4) with Bits DB[20:19] set to 01 and the chosen fastlock timer value (DB18 to DB7). Note that the duration that the PLL remains in wide bandwidth is equal to the fastlock timer/ f_{PFD} .

FASTLOCK: AN EXAMPLE

If a PLL has $f_{\text{PFD}} = 13$ MHz and a required lock time of 50 μs , the PLL is set to wide bandwidth for 40 μs .

If the time period set for the wide bandwidth is 40 μs , then

$$\text{Fastlock Timer Value} = \text{Time in Wide Bandwidth} \times f_{\text{PFD}}$$

$$\text{Fastlock Timer Value} = 40 \mu\text{s} \times 13 \text{ MHz} = 520$$

Therefore, 520 must be loaded into the clock divider value in Register 4 (R4) in Step 2 of the sequence described in the Fastlock Timer and Register Sequences section.

FASTLOCK: LOOP FILTER TOPOLOGY

To use fast-lock mode, an extra connection from the PLL to the loop filter is needed. The damping resistor in the loop filter must be reduced to $\frac{1}{4}$ of its value while in wide bandwidth mode. This is required because the charge pump current is increased by 16 while in wide bandwidth mode, and stability must be ensured. During fastlock, the MUXOUT pin (after setting MUXOUT to fastlock switch by setting Bits DB[30:27] in Register 0 to 1100) is shorted to ground (this is accomplished by settings Bits DB[20:19] in Register 4 to 01—switched R fastlock enable). The following two topologies can be used:

- Divide the damping resistor (R1) into two values (R1 and R1A) that have a ratio of 1:3 (see Figure 22).
- Connect an extra resistor (R1A) directly from MUXOUT, as shown in Figure 23. The extra resistor must be chosen such that the parallel combination of an extra resistor and the damping resistor (R1) is reduced to $\frac{1}{4}$ of the original value of R1 (see Figure 23).

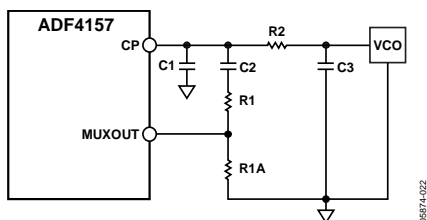

Figure 22. Fast-Lock Loop Filter Topology—Topology 1

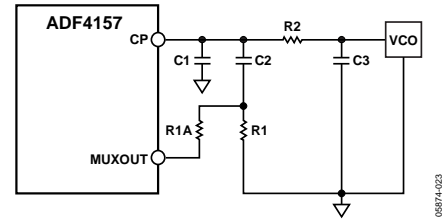

Figure 23. Fastlock Loop Filter Topology—Topology 2

SPUR MECHANISMS

The fractional interpolator in the ADF4157 is a third-order Σ - Δ modulator (SDM) with a 25-bit fixed modulus (MOD). The SDM is clocked at the PFD reference rate (f_{PFD}) that allows PLL output frequencies to be synthesized at a channel step resolution of $f_{\text{PFD}}/\text{MOD}$. The various spur mechanisms possible with fractional-N synthesizers, and how they affect the ADF4157, are discussed in this section.

Fractional Spurs

In most fractional synthesizers, fractional spurs can appear at the set channel spacing of the synthesizer. In the ADF4157, these spurs do not appear. The high value of the fixed modulus in the ADF4157 makes the Σ - Δ modulator quantization error spectrum look like broadband noise, effectively spreading the fractional spurs into noise.

Integer Boundary Spurs

Interactions between the RF VCO frequency and the PFD frequency can lead to spurs known as integer boundary spurs. When these frequencies are not integer related (which is the purpose of the fractional-N synthesizer), spur sidebands appear on the VCO output spectrum at an offset frequency that corresponds to the beat note or difference frequency between an integer multiple of the PFD and the VCO frequency.

These spurs are named integer boundary spurs because they are more noticeable on channels close to integer multiples of the PFD where the difference frequency can be inside the loop bandwidth. These spurs are attenuated by the loop filter.

Figure 7 shows an integer boundary spur. The RF frequency is 5800.25 MHz, and the PFD frequency is 25 MHz. The integer boundary spur is 250 kHz from the carrier at an integer times the PFD frequency ($232 \times 25 \text{ MHz} = 5800 \text{ MHz}$). The spur also appears on the upper sideband.

Reference Spurs

Reference spurs are generally not a problem in fractional-N synthesizers because the reference offset is far outside the loop bandwidth. However, any reference feedthrough mechanism that bypasses the loop can cause a problem. One such mechanism is the feedthrough of low levels of on-chip reference switching noise out through the $\text{RF}_{\text{IN},x}$ pin back to the VCO, resulting in reference spur levels as high as -90 dBc. Care should be taken in the PCB layout to ensure that the VCO is well separated from the input reference to avoid a possible feedthrough path on the board.

LOW FREQUENCY APPLICATIONS

The specification on the RF input is 0.5 GHz minimum; however, RF frequencies lower than this can be used, providing the minimum slew rate specification of 400 V/ μ s is met. An appropriate LVDS driver can be used to square up the RF signal before it is fed back to the ADF4157 RF input. The FIN1001 from Fairchild Semiconductor is one such LVDS driver.

FILTER DESIGN—ADIsimPLL

A filter design and analysis program is available to help the user implement PLL design. Visit www.analog.com/pll for a free download of the ADIsimPLL™ software. The software designs, simulates, and analyzes the entire PLL frequency domain and time domain response. Various passive and active filter architectures are allowed.

OPERATING WITH WIDE LOOP FILTER BANDWIDTHS

If a wide loop filter bandwidth is used (>60 kHz), fluctuations in the phase noise profile may be noticed on channels that are close to integer multiples of the PFD frequency. This is due to operation of the charge pump close to the dead zone. To improve the phase noise, a bleed current can be enabled to bias the charge pump away from the dead zone. To enable this, set Bit DB[24:23] in Register 4. Using this mode has the added advantage of improving the integer boundary spurs by 4 dB to 5 dB. Note that it is also safe to use this mode if the loop filter bandwidth is <60 kHz.

PCB DESIGN GUIDELINES FOR THE CHIP SCALE PACKAGE

The lands on the chip scale package (CP-20) are rectangular. The printed circuit board pad for these should be 0.1 mm longer than the package land length and 0.05 mm wider than the package land width. The land should be centered on the pad. This ensures that the solder joint size is maximized.

The bottom of the chip scale package has a central thermal pad. The thermal pad on the printed circuit board (PCB) should be at least as large as the exposed pad. On the printed circuit board, there should be a clearance of at least 0.25 mm between the thermal pad and the inner edges of the pad pattern. This ensures that shorting is avoided.

Thermal vias can be used on the PCB thermal pad to improve thermal performance of the package. If vias are used, they should be incorporated into the thermal pad at 1.2 mm pitch grid. The via diameter should be between 0.3 mm and 0.33 mm, and the via barrel should be plated with 1 ounce of copper to plug the via. The user should connect the PCB thermal pad to AGND.

OUTLINE DIMENSIONS

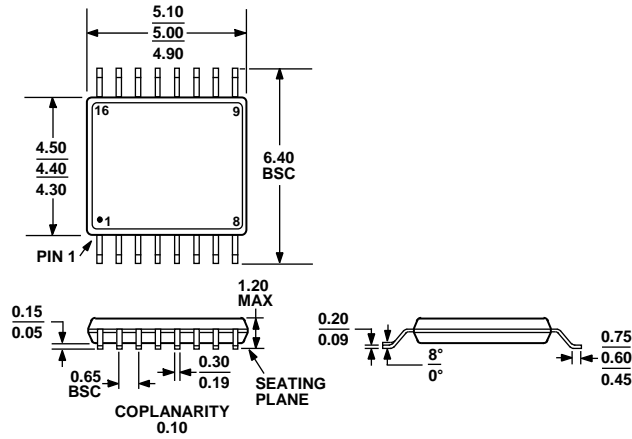

COMPLIANT TO JEDEC STANDARDS MO-153-AB

Figure 24. 16-Lead Thin Shrink Small Outline Package [TSSOP] (RU-16)

Dimensions shown in millimeters

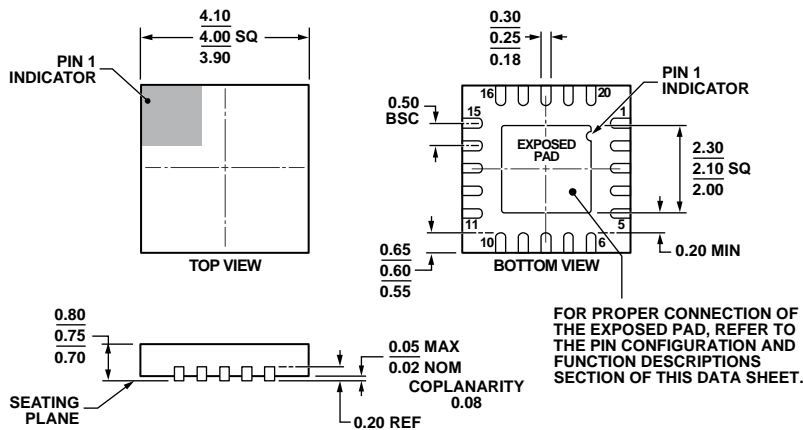

COMPLIANT TO JEDEC STANDARDS MO-220-WGGD-1.

Figure 25. 20-Lead Lead Frame Chip Scale Package [LFCSP_WQ] 4mm x 4 mm Body, Very Very Thin Quad (CP-20-6)

Dimensions shown in millimeters

ORDERING GUIDE

| Model ¹ | Description | Temperature Range | Package Option |
|--------------------|---|-------------------|----------------|
| ADF4157BRUZ | 16-Lead Thin Shrink Small Outline Package [TSSOP] | -40°C to +85°C | RU-16 |
| ADF4157BRUZ-RL | 16-Lead Thin Shrink Small Outline Package [TSSOP] | -40°C to +85°C | RU-16 |
| ADF4157BRUZ-RL7 | 16-Lead Thin Shrink Small Outline Package [TSSOP] | -40°C to +85°C | RU-16 |
| ADF4157BCPZ | 20-Lead Lead Frame Chip Scale Package [LFCSP_WQ] | -40°C to +85°C | CP-20-6 |
| ADF4157BCPZ-RL | 20-Lead Lead Frame Chip Scale Package [LFCSP_WQ] | -40°C to +85°C | CP-20-6 |
| ADF4157BCPZ-RL7 | 20-Lead Lead Frame Chip Scale Package [LFCSP_WQ] | -40°C to +85°C | CP-20-6 |
| EV-ADF4157SD1Z | Evaluation Board | | |

¹ Z = RoHS Compliant Part.

NOTES

NOTES

NOTES

Looking for pricing, stock, or lifecycle information?

Click below to explore more details on WIN SOURCE:

 [View ADF4157BRUZ-RL7 on WIN SOURCE](#)

 [Analog Devices Inc. Information](#)

Optimize Your Supply Chain with WIN SOURCE Solutions

-  Global Sourcing Solution
-  Obsolete Management
-  Cost Control Management
-  Shortage Management
-  Alternative Solution
-  Excess Inventory Management