



**THE DATASHEET OF  
AD9152BCPZ**



## FEATURES

- Supports input data rates up to 1.125 GSPS
- Proprietary low spurious and distortion design
  - Single carrier LTE 20 MHz bandwidth (BW), ACLR = 77 dBc at 180 MHz IF
  - SFDR = 72 dBc at 150 MHz IF, -6 dBFS
- Flexible 4-lane JESD204B interface
- Multiple chip synchronization
  - Fixed latency
  - Data generator latency compensation
- Selectable 1x, 2x, 4x, and 8x interpolation filter
- Low power architecture
- Input signal power detection
  - Emergency stop for downstream analog circuitry protection
- Transmit enable function allows extra power saving
- High performance, low noise, phase-locked loop (PLL) clock multiplier
- Digital inverse sinc filter and programmable finite impulse response (FIR) filter
- Low power: 1223 mW at 1.5 GSPS, 1406 mW at 2.0 GSPS, full operating conditions
- 56-lead LFCSP with exposed pad

## APPLICATIONS

- Wireless communications
  - Multicarrier LTE and GSM base stations
  - Wideband repeaters
  - Software defined radios
- Wideband communications
  - Point to point microwave radios
  - LMDS/MMDS
- Transmit diversity, multiple input/multiple output (MIMO)
- Instrumentation
- Automated test equipment

## GENERAL DESCRIPTION

The AD9152 is a dual, 16-bit, high dynamic range digital-to-analog converter (DAC) that provides a maximum sample rate of 2.25 GSPS, permitting a multicarrier generation up to the Nyquist frequency. The DAC outputs are optimized to interface seamlessly with the ADRF6720 analog quadrature modulator (AQM) from Analog Devices, Inc. An optional 3-wire or 4-wire serial port interface (SPI) provides for programming/readback of many internal parameters. The full-scale output current can be programmed over a range of 4 mA to 20 mA. The AD9152 is available in a 56-lead LFCSP. The AD9152 is a member of the TxDAC+® family.

## PRODUCT HIGHLIGHTS

1. Ultrawide signal bandwidth enables emerging wideband and multiband wireless applications.
2. Advanced low spurious and distortion design techniques provide high quality synthesis of wideband signals from baseband to high intermediate frequencies.
3. JESD204B Subclass 1 support simplifies multichip synchronization in software and hardware design.
4. Fewer pins for data interface width with the serializer/deserializer (SERDES) JESD204B four-lane interface.
5. Programmable transmit enable function allows easy design balance between power consumption and wake-up time.
6. Small package size with an 8 mm × 8 mm footprint.

## FUNCTIONAL BLOCK DIAGRAM

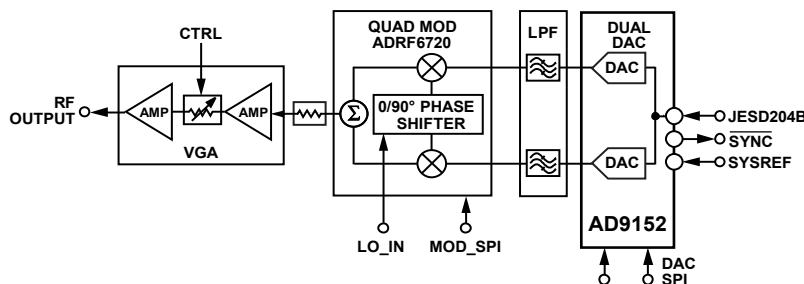

Figure 1.

Rev. B

[Document Feedback](#)

Information furnished by Analog Devices is believed to be accurate and reliable. However, no responsibility is assumed by Analog Devices for its use, nor for any infringements of patents or other rights of third parties that may result from its use. Specifications subject to change without notice. No license is granted by implication or otherwise under any patent or patent rights of Analog Devices. Trademarks and registered trademarks are the property of their respective owners.

One Technology Way, P.O. Box 9106, Norwood, MA 02062-9106, U.S.A.  
Tel: 781.329.4700 ©2015–2017 Analog Devices, Inc. All rights reserved.  
[Technical Support](#) [www.analog.com](http://www.analog.com)

## TABLE OF CONTENTS

Features .....	1	Interpolation .....	27
Applications .....	1	JESD204B Setup .....	27
General Description .....	1	SERDES Clocks Setup .....	28
Product Highlights .....	1	Equalization Mode Setup .....	28
Functional Block Diagram .....	1	Link Latency Setup .....	28
Revision History .....	3	Crossbar Setup .....	30
Detailed Functional Block Diagram .....	4	JESD204B Serial Data Interface .....	31
Specifications .....	5	JESD204B Overview .....	31
DC Specifications .....	5	Physical Layer .....	32
Digital Specifications .....	6	Data Link Layer .....	35
Maximum DAC Update Rate Speed Specifications by Supply .....	7	Transport Layer .....	43
JESD204B Serial Interface Speed Specifications .....	7	JESD204B Test Modes .....	51
SYSREF± to DAC Clock Timing Specifications .....	8	JESD204B Error Monitoring .....	52
Digital Input Data Timing Specifications .....	8	Digital Datapath .....	54
Latency Variation Specifications .....	9	Data Format .....	54
JESD204B Interface Electrical Specifications .....	9	Interpolation Filters .....	54
AC Specifications .....	10	Digital Modulation .....	55
Absolute Maximum Ratings .....	11	NCO Alignment .....	56
Thermal Resistance .....	11	Inverse Sinc .....	57
ESD Caution .....	11	Programmable FIR Filter (PFIR) .....	57
Pin Configuration and Function Descriptions .....	12	Digital Gain, Phase Adjust, DC Offset, and Coarse Group Delay .....	57
Terminology .....	14	Downstream Protection .....	59
Typical Performance Characteristics .....	15	Datapath PRBS .....	61
Theory of Operation .....	20	DC Test Mode .....	62
Serial Port Operation .....	21	Interrupt Request Operation .....	63
Data Format .....	21	Interrupt Service Routine .....	63
Serial Port Pin Descriptions .....	21	DAC Input Clock Configurations .....	64
Serial Port Options .....	21	Driving the DACCLK± AND REFCLK± Inputs .....	64
Chip Information .....	23	Condition Specific Register Writes .....	64
Device Setup Guide .....	24	Starting the PLL .....	65
Overview .....	24	Analog Outputs .....	67
Step 1: Start Up the DAC .....	24	Transmit DAC Operation .....	67
Step 2: Digital Datapath .....	25	Temperature Sensor .....	68
Step 3: Transport Layer .....	25	Example Start-Up Sequence .....	69
Step 4: Physical Layer .....	26	Step 1: Start Up the DAC .....	69
Step 5: Data Link Layer .....	26	Step 2: Digital Datapath .....	70
Step 6: Optional Error Monitoring .....	26	Step 3: Transport Layer .....	70
Step 7: Optional Features .....	26	Step 4: Physical Layer .....	70
DAC PLL Setup .....	27	Step 5: Data Link Layer .....	70

Step 6: Optional Error Monitoring .....	70	Device Configuration Register Map.....	74
Board Level Hardware Considerations .....	71	Device Configuration Register Descriptions .....	79
Power Supply Recommendations .....	71	Outline Dimensions.....	103
JESD204B Serial Interface Inputs (SERDIN0± to SERDIN3±).....	71	Ordering Guide .....	103
Register Map and Descriptions .....	74		

## REVISION HISTORY

### 8/2017—Rev. A to Rev. B

Change to Output Compliance Range Parameter; Table 1.....	5
Updated Outline Dimensions.....	103
Changes to Ordering Guide.....	103

### 2/2017—Rev. 0 to Rev. A

Changes to Figure 2.....	4
Change to Device Revision Parameter, Table 14.....	23
Changes to Step 1: Start Up the DAC Section and Table 16.....	24
Changes to Digital Datapath Section, Address 0x14, Table 17, and Table 18 .....	26
Change to JESD204B Setup Section .....	27
Changes to SERDES PLL Fixed Register Writes Section .....	33
Added Table 36; Renumbered Sequentially .....	33
Change to Register Block 0x47, Bit 4, Table 69 .....	63
Deleted DAC PLL Fixed Register Writes Section, Figure 70, and Figure 71; Renumbered Sequentially .....	64
Changes to Temperature Tracking Section, Starting the PLL Section, and Table 73 .....	65
Changes to Table 76 and Table 77 .....	69
Changes to Table 78 .....	70
Changes to Table 85 .....	74
Changes to Table 86 .....	80

### 4/2015—Revision 0: Initial Version

DETAILED FUNCTIONAL BLOCK DIAGRAM

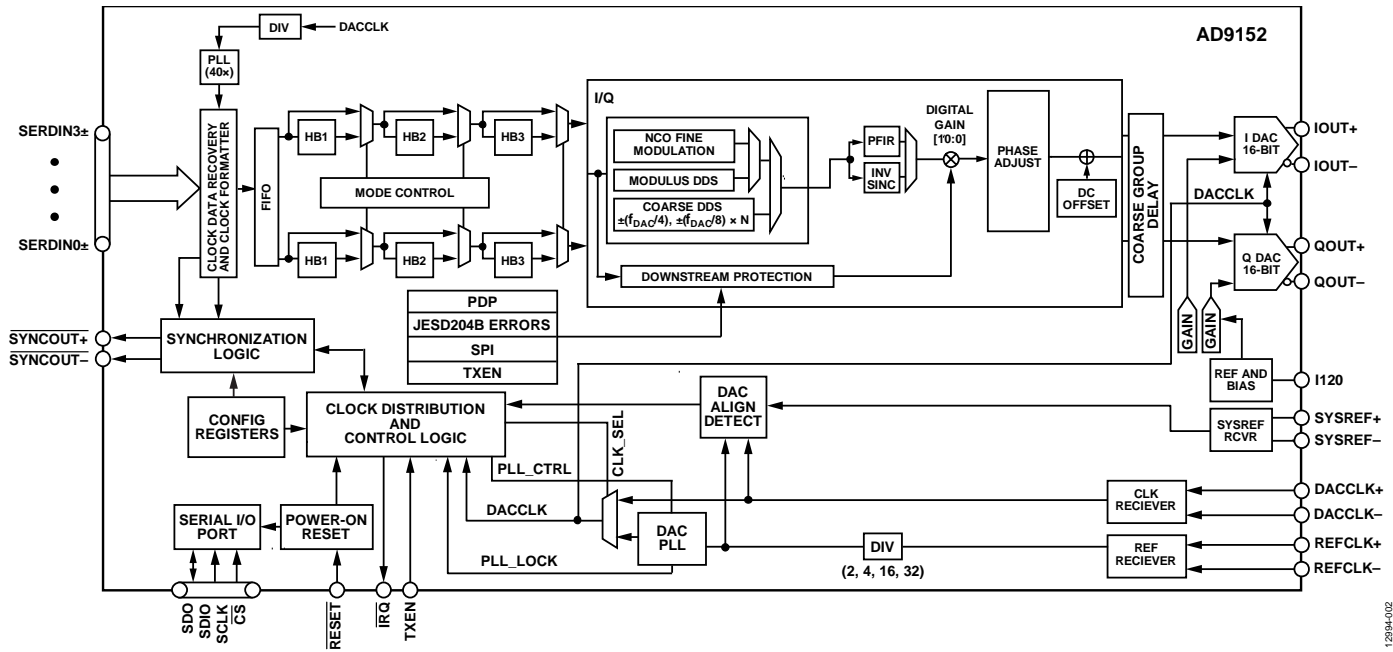

Figure 2. Detailed Functional Block Diagram

129194-002

## SPECIFICATIONS

### DC SPECIFICATIONS

AVDD33 = 3.3 V, SIOVDD33 = 3.3 V, IOVDD = 1.8 V, DVDD12 = 1.2 V, CVDD12 = 1.2 V, PVDD12 = 1.2 V, PLLVDD12 = 1.2 V, SVDD12 = 1.2 V, SDVDD12 = 1.2 V,  $V_{TT} = 1.2$  V,  $T_A = -40^\circ\text{C}$  to  $+85^\circ\text{C}$ ,  $I_{OUTFS} = 20$  mA, unless otherwise noted.

Table 1.

Parameter	Test Conditions/Comments	Min	Typ	Max	Unit
RESOLUTION			16		Bits
ACCURACY					
Differential Nonlinearity (DNL)			±5.0		LSB
Integral Nonlinearity (INL)			±10.0		LSB
MAIN DAC OUTPUTS					
Gain Error	With internal reference	-5.5	-1.3	+5.5	% FSR
I/Q Gain Mismatch		-4.5		+4.5	% FSR
Full-Scale Output Current ( $I_{OUTFS}$ )	Based on a 4 k $\Omega$ external resistor between I120 and ground				
Maximum Setting		19.1	20.22	21.4	mA
Minimum Setting		3.8	4.04	4.3	mA
Output Compliance Range		2.3		3.47	V
Output Resistance			15		M $\Omega$
Output Capacitance			3.0		pF
Gain DAC Monotonicity			Guaranteed		
MAIN DAC TEMPERATURE DRIFT					
Offset			0.1		ppm/ $^\circ\text{C}$
Gain			35		ppm/ $^\circ\text{C}$
Reference Voltage			25		ppm/ $^\circ\text{C}$
REFERENCE					
Internal Reference Voltage			0.5		V
ANALOG SUPPLY VOLTAGES					
AVDD33	±5%	3.13	3.3	3.47	V
PVDD12, CVDD12	±5%	1.14	1.2	1.26	V
	±2%	1.274	1.3	1.326	V
SVDD12, PLLVDD12, $V_{TT}$	±5%	1.14	1.2	1.26	V
	±2%	1.274	1.3	1.326	V
DIGITAL SUPPLY VOLTAGES					
DVDD12, SDVDD12	±5%	1.14	1.2	1.26	V
	±2%	1.274	1.3	1.326	V
SIOVDD33	±5%	3.13	3.3	3.47	V
IOVDD	±5%	1.71	1.8	3.47	V
POWER CONSUMPTION					
Total Power	2 $\times$ interpolation mode, $f_{DAC} = 1.5$ GSPS, IF = 70 MHz, PLL off, INVSINC on, digital gain on, NCO on, JESD204B Mode 4, four SERDES lanes with 7.5 Gbps lane rate, $I_{OUTFS} = 20$ mA		1223		mW
AVDD33			87		mA
PVDD12			11		mA
CVDD12			179		mA
SDVDD12 and SVDD12 (Includes PLLVDD12 and $V_{TT}$ )			328		mA
DVDD12			246		mA
SIOVDD33 and IOVDD			5.7		mA
OPERATING TEMPERATURE RANGE		-40	+25	+85	$^\circ\text{C}$

**DIGITAL SPECIFICATIONS**

AVDD33 = 3.3 V, SIOVDD33 = 3.3 V, IOVDD = 1.8 V, DVDD12 = 1.2 V, CVDD12 = 1.2 V, PVDD12 = 1.2 V, PLLVDD12 = 1.2 V, SVDD12 = 1.2 V, SDVDD12 = 1.2 V,  $V_{TT} = 1.2$  V,  $T_A = -40^\circ\text{C}$  to  $+85^\circ\text{C}$ ,  $I_{OUTFS} = 20$  mA, unless otherwise noted.

Table 2.

Parameter	Symbol	Test Conditions/Comments	Min	Typ	Max	Unit
CMOS INPUT LOGIC LEVEL						
Input Voltage Logic	$V_{IN}$					
High		$1.8\text{ V} \leq \text{IOVDD} \leq 3.3\text{ V}$	$0.7 \times \text{IOVDD}$			V
Low		$1.8\text{ V} \leq \text{IOVDD} \leq 3.3\text{ V}$			$0.3 \times \text{IOVDD}$	V
CMOS OUTPUT LOGIC LEVEL						
Output Voltage Logic	$V_{OUT}$					
High		$1.8\text{ V} \leq \text{IOVDD} \leq 3.3\text{ V}$	$0.7 \times \text{IOVDD}$			V
Low		$1.8\text{ V} \leq \text{IOVDD} \leq 3.3\text{ V}$			$0.3 \times \text{IOVDD}$	V
MAXIMUM DAC UPDATE RATE <sup>1</sup>		DVDD12 = CVDD12 = PVDD12 = 1.3 V $\pm$ 2% 1 $\times$ interpolation <sup>2</sup> 2 $\times$ interpolation 4 $\times$ interpolation 8 $\times$ interpolation	1238 2250 2250 2250			MSPS MSPS MSPS MSPS
ADJUSTED DAC UPDATE RATE		DVDD12 = CVDD12 = PVDD12 = 1.3 V $\pm$ 2% 1 $\times$ interpolation 2 $\times$ interpolation 4 $\times$ interpolation 8 $\times$ interpolation	1238 1125 562.5 281.25			MSPS MSPS MSPS MSPS
INTERFACE <sup>3</sup>						
Number of JESD204B Lanes				4		Lanes
JESD204B Serial Interface Speed		SVDD12 = SDVDD12 = PLLVDD12 = 1.3 V $\pm$ 2%				
Minimum		Per lane			1.44	Gbps
Maximum		Per lane	12.38			Gbps
DAC CLOCK INPUT (DACCLK $\pm$ )						
Differential Peak-to-Peak Voltage		Self biased input, ac-coupled	400	1000	2000	mV
Common-Mode Voltage				600		mV
Maximum Clock Rate		DVDD12 = CVDD12 = PVDD12 = 1.3 V $\pm$ 2%	2250			MHz
REFERENCE CLOCK INPUT (REFCLK $\pm$ )						
Differential Peak-to-Peak Voltage		Self biased input, ac-coupled	400	1000	2000	mV
Common-Mode Voltage				600		mV
Input Clock Frequency (PLL Mode)		6 GHz $\leq f_{VCO} \leq$ 12 GHz	70		1000	MHz
SYSTEM REFERENCE INPUT (SYSREF $\pm$ )						
Differential Peak-to-Peak Voltage			400	1000	2000	mV
Common-Mode Voltage			0		2000	mV
SYSREF $\pm$ Frequency <sup>4</sup>					$f_{DATA}/(K \times S)$	Hz
SYSREF $\pm$ TO DAC CLOCK <sup>5</sup>		SYSREF $\pm$ differential swing = 1.2 V, slew rate = 6.3 V/ns, hysteresis off (ac-coupled, and 0 V, 0.6 V, 1.25 V, 2.0 V dc-coupled common-mode voltages)				
Setup Time	$t_{SSD}$		-6			ps
Hold Time	$t_{HSD}$		224			ps
Keep Out Window	KOW			218		ps

Parameter	Symbol	Test Conditions/Comments	Min	Typ	Max	Unit
SPI						
Maximum Clock Rate	SCLK	IOVDD = 1.8 V	10			MHz
Minimum SCLK Pulse Width						
High	t <sub>PWH</sub>				8	ns
Low	t <sub>PWL</sub>				12	ns
SDIO to SCLK						
Setup Time	t <sub>DS</sub>		5			ns
Hold Time	t <sub>DH</sub>		2			ns
SDO to SCLK						
Data Valid Window	t <sub>DV</sub>		26			ns
CS to SCLK						
Setup Time	t <sub>S<math>\overline{CS}</math></sub>		5			ns
Hold Time	t <sub>H<math>\overline{CS}</math></sub>		2			ns

<sup>1</sup> See Table 3 and Table 4 for detailed specifications for the DAC update rate conditions.

<sup>2</sup> The maximum speed for 1× interpolation is limited by the JESD2040B interface. See Table 4 for details.

<sup>3</sup> See Table 4 for detailed specifications for JESD2040B speed conditions.

<sup>4</sup> K and S are JESD204B transport layer parameters. See Table 41 for the full definitions.

<sup>5</sup> See Table 5 for detailed specifications for SYSREF± to DAC clock timing conditions.

### MAXIMUM DAC UPDATE RATE SPEED SPECIFICATIONS BY SUPPLY

AVDD33 = 3.3 V, SIOVDD33 = 3.3 V, IOVDD = 1.8 V, DVDD12 = 1.2 V, CVDD12 = 1.2 V, PVDD12 = 1.2 V, PLLVDD12 = 1.2 V, SVDD12 = 1.2 V, SDVDD12 = 1.2 V, V<sub>TT</sub> = 1.2 V, T<sub>A</sub> = -40°C to +85°C, I<sub>OUTFS</sub> = 20 mA, unless otherwise noted.

Table 3.

Parameter	Test Conditions/Comments	Min	Typ	Max	Unit
MAXIMUM DAC UPDATE RATE	DVDD12, CVDD12 = 1.2 V ± 5%	1.85			GSPS
	DVDD12, CVDD12 = 1.3 V ± 2%	2.25			GSPS

### JESD204B SERIAL INTERFACE SPEED SPECIFICATIONS

AVDD33 = 3.3 V, SIOVDD33 = 3.3 V, IOVDD = 1.8 V, DVDD12 = 1.2 V, CVDD12 = 1.2 V, PVDD12 = 1.2 V, PLLVDD12 = 1.2 V, SVDD12 = 1.2 V, SDVDD12 = 1.2 V, V<sub>TT</sub> = 1.2 V, T<sub>A</sub> = -40°C to +85°C, I<sub>OUTFS</sub> = 20 mA, unless otherwise noted.

Table 4.

Parameter	Test Conditions/Comments	Min	Typ	Max	Unit
HALF RATE	SVDD12, SDVDD12, PLLVDD12 = 1.2 V ± 5%	5.75		11.00	Gbps
	SVDD12, SDVDD12, PLLVDD12 = 1.3 V ± 2%	5.75		12.38	Gbps
FULL RATE	SVDD12, SDVDD12, PLLVDD12 = 1.2 V ± 5%	2.88		5.53	Gbps
	SVDD12, SDVDD12, PLLVDD12 = 1.3 V ± 2%	2.88		6.19	Gbps
OVERSAMPLING	SVDD12, SDVDD12, PLLVDD12 = 1.2 V ± 5%	1.44		2.69	Gbps
	SVDD12, SDVDD12, PLLVDD12 = 1.3 V ± 2%	1.44		3.09	Gbps

**SYSREF± TO DAC CLOCK TIMING SPECIFICATIONS**

AVDD33 = 3.3 V, SIOVDD33 = 3.3 V, IOVDD = 1.8 V, DVDD12 = 1.2 V, CVDD12 = 1.2 V, PVDD12 = 1.2 V, PLLVDD12 = 1.2 V, SVDD12 = 1.2 V, SDVDD12 = 1.2 V, V<sub>TT</sub> = 1.2 V, T<sub>A</sub> = -40°C to +85°C, I<sub>OUTFS</sub> = 20 mA, SYSREF± common-mode voltages = 0.0 V, 0.6 V, 1.25 V, and 2.0 V, unless otherwise noted.

Table 5.

Parameter	Test Conditions/Comments	Min	Typ	Max	Unit
SYSREF	Differential swing = 1.2 V, slew rate = 6.3 V/ns				
Hysteresis Off					
Setup Time	AC-coupled	-9			ps
	DC-coupled	-6			ps
Hold Time	AC-coupled	199			ps
	DC-coupled	224			ps
Hysteresis On (HYS_CNTRL = 0x3FF)					
Setup Time	AC-coupled	143			ps
	DC-coupled	145			ps
Hold Time	AC-coupled	97			ps
	DC-coupled	123			ps

**DIGITAL INPUT DATA TIMING SPECIFICATIONS**

AVDD33 = 3.3 V, SIOVDD33 = 3.3 V, IOVDD = 1.8 V, DVDD12 = 1.2 V, CVDD12 = 1.2 V, PVDD12 = 1.2 V, PLLVDD12 = 1.2 V, SVDD12 = 1.2 V, SDVDD12 = 1.2 V, V<sub>TT</sub> = 1.2 V, T<sub>A</sub> = -40°C to +85°C, I<sub>OUTFS</sub> = 20 mA, unless otherwise noted.

Table 6.

Parameter	Test Conditions/Comments	Min	Typ	Max	Unit
LATENCY					
Interface			17		PClock <sup>1</sup> cycles
Interpolation					
1×			143		DAC clock cycles
2×			163		DAC clock cycles
4×			287		DAC clock cycles
8×			557		DAC clock cycles
Inverse Sinc			17		DAC clock cycles
Fine Modulation			20		DAC clock cycles
Coarse Modulation					
f <sub>s</sub> /8			8		DAC clock cycles
f <sub>s</sub> /4			4		DAC clock cycles
Digital Phase Adjust			12		DAC clock cycles
Digital Gain Adjust			12		DAC clock cycles
Power-Up Time	Register 0x011 from 0x60 to 0x00		60		μs

<sup>1</sup> PClock is the AD9152 internal processing clock and equals the lane rate ÷ 40.

**LATENCY VARIATION SPECIFICATIONS**

AVDD33 = 3.3 V, SIOVDD33 = 3.3 V, IOVDD = 1.8 V, DVDD12 = 1.2 V, CVDD12 = 1.2 V, PVDD12 = 1.2 V, PLLVDD12 = 1.2 V, SVDD12 = 1.2 V, SDVDD12 = 1.2 V,  $V_{TT} = 1.2$  V,  $T_A = -40^\circ\text{C}$  to  $+85^\circ\text{C}$ ,  $I_{OUTFS} = 20$  mA, unless otherwise noted.

Table 7.

Parameter	Test Conditions/Comments	Min	Typ	Max	Unit
DAC LATENCY VARIATION	Given proper calibration of the local multiframe clock (LMFC) delay				
Subclass 1					DAC clock cycles
PLL Off		-3	0	+3	DAC clock cycles
PLL On		-4		+4	DAC clock cycles

**JESD204B INTERFACE ELECTRICAL SPECIFICATIONS**

AVDD33 = 3.3 V, SIOVDD33 = 3.3 V, IOVDD = 1.8 V, DVDD12 = 1.2 V, CVDD12 = 1.2 V, PVDD12 = 1.2 V, PLLVDD12 = 1.2 V, SVDD12 = 1.2 V, SDVDD12 = 1.2 V,  $V_{TT} = 1.2$  V,  $T_A = -40^\circ\text{C}$  to  $+85^\circ\text{C}$ ,  $I_{OUTFS} = 20$  mA, unless otherwise noted.

Table 8.

Parameter	Symbol	Test Conditions/Comments	Min	Typ	Max	Unit
JESD204B DATA INPUTS						
Input Leakage Current		$T_A = 25^\circ\text{C}$				
Logic High		Input level = $1.2\text{ V} \pm 0.25\text{ V}$ , $V_{TT} = 1.2\text{ V}$		10		$\mu\text{A}$
Logic Low		Input level = $0\text{ V}$		-4		$\mu\text{A}$
Unit Interval	UI		81		694	ps
Common-Mode Voltage	$V_{RCM}$	AC-coupled $V_{TT} = \text{SVDD12}^1$	-0.05		+1.85	V
Differential Voltage	$R_{V_{DIFF}}$		110		1050	mV
$V_{TT}$ Source Impedance	$Z_{TT}$	At dc			30	$\Omega$
Differential Impedance	$Z_{R_{DIFF}}$	At dc	80	100	120	$\Omega$
Differential Return Loss	$RL_{RDIF}$			8		dB
Common-Mode Return Loss	$RL_{RCM}$			6		dB
DIFFERENTIAL OUTPUTS (SYNCOUT $\pm$ ) <sup>2</sup>						
Output Offset Voltage	$V_{OS}$		1.15		1.25	V
Output Differential Voltage	$V_{OD}$	High swing mode: Register 0x230, Bit 0 = 1	350		410	mV
DETERMINISTIC LATENCY						
Fixed					17	PClock <sup>3</sup> cycles
Variable					2	PClock <sup>3</sup> cycles
SYSREF $\pm$ TO LMFC DELAY				4		DAC clock cycles

<sup>1</sup> As measured on the input side of the ac coupling capacitor.

<sup>2</sup> IEEE Standard 1596.3 LVDS compatible.

<sup>3</sup> PClock is the AD9152 internal processing clock and equals the lane rate  $\div$  40.

**AC SPECIFICATIONS**

AVDD33 = 3.3 V, SIOVDD33 = 3.3 V, IOVDD = 1.8 V, DVDD12 = 1.2 V, CVDD12 = 1.2 V, PVDD12 = 1.2 V, PLLVDD12 = 1.2 V, SVDD12 = 1.2 V, SDVDD12 = 1.2 V,  $V_{TT} = 1.2$  V,  $T_A = -40^{\circ}\text{C}$  to  $+85^{\circ}\text{C}$ ,  $I_{OUTFS} = 20$  mA, unless otherwise noted.

**Table 9.**

Parameter	Test Conditions/Comments	Min	Typ	Max	Unit
SPURIOUS-FREE DYNAMIC RANGE (SFDR) $f_{DAC} = 1966.08$ MSPS	-6 dBFS single tone				
	$f_{OUT} = 20$ MHz		76		dBc
	$f_{OUT} = 150$ MHz		72		dBc
	$f_{OUT} = 180$ MHz		68		dBc
TWO-TONE THIRD INTERMODULATION DISTORTION (IMD) $f_{DAC} = 983.04$ MSPS	-6 dBFS				
	$f_{OUT} = 30$ MHz		86		dBc
	$f_{OUT} = 150$ MHz		79		dBc
	$f_{OUT} = 180$ MHz		78		dBc
NOISE SPECTRAL DENSITY (NSD), SINGLE TONE $f_{DAC} = 983.04$ MSPS $f_{DAC} = 1966.08$ MSPS	0 dBFS				
	$f_{OUT} = 150$ MHz $f_{OUT} = 180$ MHz		-162.5 -163		dBm/Hz dBm/Hz
5 MHz BW LTE FIRST ADJACENT CHANNEL LEAKAGE RATIO (ACLR), SINGLE CARRIER $f_{DAC} = 1966.08$ MSPS	0 dBFS, PLL off				
	$f_{OUT} = 50$ MHz		79		dBc
	$f_{OUT} = 150$ MHz		77		dBc
	$f_{OUT} = 180$ MHz		77		dBc
5 MHz BW LTE SECOND ACLR, SINGLE CARRIER $f_{DAC} = 1966.08$ MSPS	0 dBFS, PLL off				
	$f_{OUT} = 50$ MHz		82		dBc
	$f_{OUT} = 150$ MHz		81		dBc
	$f_{OUT} = 180$ MHz		81		dBc

## ABSOLUTE MAXIMUM RATINGS

Table 10.

Parameter	Rating
I120 to Ground	−0.3 V to AVDD33 + 0.3 V
SERDIN <sub>x±</sub> , V <sub>TT</sub> , SYNCOUT <sub>±</sub> , TXEN	−0.3 V to SIOVDD33 + 0.3 V
IOUT <sub>±</sub> , QOUT <sub>±</sub>	−0.3 V to AVDD33 + 0.3 V
SYSREF <sub>±</sub>	GND − 0.5 V to +2.5 V
DACCLK <sub>±</sub> and REFCLK <sub>±</sub> to Ground	−0.3 V to PVDD12 + 0.3 V
RESET, IRQ, CS, SCLK, SDIO, SDO, PROTECT_OUT to Ground	−0.3 V to IOVDD + 0.3 V
LDO_BYP1	−0.3 V to SVDD12 + 0.3 V
LDO_BYP2	−0.3 V to PVDD12 + 0.3 V
Ambient Operating Temperature (T <sub>A</sub> )	−40°C to +85°C
Junction Temperature	125°C
Storage Temperature Range	−65°C to +150°C

Stresses at or above those listed under Absolute Maximum Ratings may cause permanent damage to the product. This is a stress rating only; functional operation of the product at these or any other conditions above those indicated in the operational section of this specification is not implied. Operation beyond the maximum operating conditions for extended periods may affect product reliability.

## THERMAL RESISTANCE

The exposed pad (EPAD) must be soldered to the ground plane for the 56-lead LFCSP. The EPAD provides an electrical, thermal, and mechanical connection to the board.

Typical  $\theta_{JA}$ ,  $\theta_{JB}$ , and  $\theta_{JC}$  values are specified for a 4-layer JESD51-7 high effective thermal conductivity test board for leaded surface-mount packages.  $\theta_{JA}$  is obtained in still air conditions (JESD51-2). Airflow increases heat dissipation, effectively reducing  $\theta_{JA}$ .  $\theta_{JB}$  is obtained following double-ring cold plate test conditions (JESD51-8).  $\theta_{JC}$  is obtained with the test case temperature monitored at the bottom of the exposed pad.

$\Psi_{JT}$  and  $\Psi_{JB}$  are thermal characteristic parameters obtained with  $\theta_{JA}$  in still air test conditions.

Junction temperature (T<sub>J</sub>) can be estimated using the following equations:

$$T_J = T_T + (\Psi_{JT} \times P)$$

or

$$T_J = T_B + (\Psi_{JB} \times P)$$

where:

T<sub>T</sub> is the temperature measured at the top of the package.

P is the total device power dissipation.

T<sub>B</sub> is the temperature measured at the board.

Table 11. Thermal Resistance

Package	$\theta_{JA}$	$\theta_{JB}$	$\theta_{JC}$	$\Psi_{JT}$	$\Psi_{JB}$	Unit
56-Lead LFCSP <sup>1</sup>	25.5	4.8	1.7	0.1	4.8	°C/W

<sup>1</sup> The exposed pad must be securely connected to the ground plane.

## ESD CAUTION



**ESD (electrostatic discharge) sensitive device.** Charged devices and circuit boards can discharge without detection. Although this product features patented or proprietary protection circuitry, damage may occur on devices subjected to high energy ESD. Therefore, proper ESD precautions should be taken to avoid performance degradation or loss of functionality.

## PIN CONFIGURATION AND FUNCTION DESCRIPTIONS

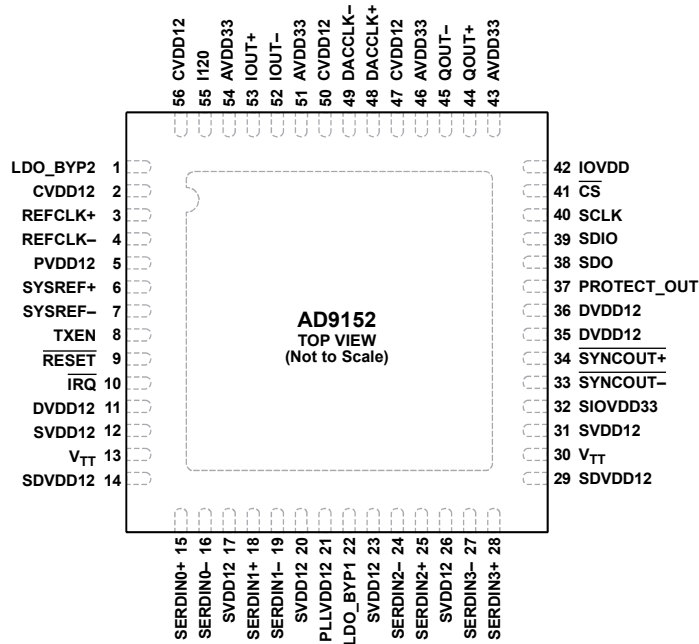

NOTES  
1. THE EXPOSED PAD MUST BE SECURELY CONNECTED TO THE GROUND PLANE.

12894-003

Figure 3. Pin Configuration

Table 12. Pin Function Descriptions

Pin No.	Mnemonic	Description
1	LDO_BYP2	LDO Clock Bypass for the DAC PLL. This pin requires a 1 $\Omega$ resistor in series with a 1 $\mu$ F capacitor to ground.
2	CVDD12	1.2 V Clock Supply.
3	REFCLK+	PLL Reference Clock Input, Positive.
4	REFCLK-	PLL Reference Clock Input, Negative.
5	PVDD12	1.2 V Supply. This pin supplies the DAC PLL and clock receiver circuitry.
6	SYSREF+	Positive Reference Clock for Deterministic Latency. This pin is self biased for ac coupling. This pin may be ac-coupled or dc-coupled.
7	SYSREF-	Negative Reference Clock for Deterministic Latency. This pin is self biased for ac coupling. This pin may be ac-coupled or dc-coupled.
8	TXEN	Transmitter (Tx) Enable for I DAC and Q DAC. CMOS levels are determined with respect to IOVDD.
9	RESET	Reset (Active Low). CMOS levels are determined with respect to IOVDD.
10	IRQ	Interrupt Request (Active Low, Open Drain).
11	DVDD12	1.2 V Digital Supply.
12	SVDD12	1.2 V JESD204B Receiver (Rx) Analog Supply.
13	V <sub>TT</sub>	1.2 V Termination Voltage. Connect this pin to the SVDD12 pin externally.
14	SDVDD12	1.2 V JESD204B Rx Digital Supply.
15	SERDIN0+	Serial Channel Input 0, Positive. CML compliant. SERDIN0+ is 50 $\Omega$ terminated to the V <sub>TT</sub> pin voltage. This pin is ac-coupled only. Resistance calibrated.
16	SERDIN0-	Serial Channel Input 0, Negative. CML compliant. SERDIN0- is 50 $\Omega$ terminated to the V <sub>TT</sub> pin voltage. This pin is ac-coupled only. Resistance calibrated.
17	SVDD12	1.2 V JESD204B Rx Analog Supply.
18	SERDIN1+	Serial Channel Input 1, Positive. CML compliant. SERDIN1+ is 50 $\Omega$ terminated to the V <sub>TT</sub> pin voltage. This pin is ac-coupled only. Resistance calibrated.
19	SERDIN1-	Serial Channel Input 1, Negative. CML compliant. SERDIN1- is 50 $\Omega$ terminated to the V <sub>TT</sub> pin voltage. This pin is ac-coupled only. Resistance calibrated.
20	SVDD12	1.2 V JESD204B Rx Analog Supply.
21	PLLVDD12	1.2 V SERDES PLL Supply.
22	LDO_BYP1	LDO SERDES Bypass. This pin requires a 1 $\Omega$ resistor in series with a 1 $\mu$ F capacitor to ground.

Pin No.	Mnemonic	Description
23	SVDD12	1.2 V JESD204B Rx Analog Supply.
24	SERDIN2-	Serial Channel Input 2, Negative. CML compliant. SERDIN2- is 50 $\Omega$ terminated to the $V_{TT}$ pin voltage. This pin is ac-coupled only. Resistance calibrated.
25	SERDIN2+	Serial Channel Input 2, Positive. CML compliant. SERDIN2+ is 50 $\Omega$ terminated to the $V_{TT}$ pin voltage. This pin is ac-coupled only. Resistance calibrated.
26	SVDD12	1.2 V JESD204B Rx Analog Supply.
27	SERDIN3-	Serial Channel Input 3, Negative. CML compliant. SERDIN3- is 50 $\Omega$ terminated to the $V_{TT}$ pin voltage. This pin is ac-coupled only. Resistance calibrated.
28	SERDIN3+	Serial Channel Input 3, Positive. CML compliant. SERDIN3+ is 50 $\Omega$ terminated to the $V_{TT}$ pin voltage. This pin is ac-coupled only. Resistance calibrated.
29	SDVDD12	1.2 V JESD204B Rx Digital Supply.
30	$V_{TT}$	1.2 V Termination Voltage. Connect $V_{TT}$ to the SVDD12 pin externally.
31	SVDD12	1.2 V JESD204B Rx Analog Supply.
32	SIOVDD33	3.3 V Supply for Equalizers.
33	SYNCOUT-	Negative LVDS Sync Output Signal.
34	SYNCOUT+	Positive LVDS Sync Output Signal.
35	DVDD12	1.2 V Digital Supply.
36	DVDD12	1.2 V Digital Supply.
37	PROTECT_OUT	Protection Indicator for I DAC and Q DAC. CMOS levels are determined with respect to IOVDD.
38	SDO	Serial Port Data Output. CMOS levels are determined with respect to IOVDD.
39	SDIO	Serial Port Data Input/Output. CMOS levels are determined with respect to IOVDD.
40	SCLK	Serial Port Clock Input. CMOS levels are determined with respect to IOVDD.
41	$\overline{CS}$	Serial Port Chip Select, Active Low. CMOS levels are determined with respect to IOVDD.
42	IOVDD	1.8 V IOVDD Supply for CMOS Input/Output and SPI.
43	AVDD33	3.3 V Analog Supply for the DAC Cores.
44	QOUT+	Q DAC Positive Current Output.
45	QOUT-	Q DAC Negative Current Output.
46	AVDD33	3.3 V Analog Supply for the DAC Cores.
47	CVDD12	1.2 V Clock Supply.
48	DACCLK+	Positive Device Clock When PLL Is Not Used.
49	DACCLK-	Negative Device Clock When PLL Is Not Used.
50	CVDD12	1.2 V Clock Supply.
51	AVDD33	3.3 V Analog Supply for the DAC Cores.
52	IOUT-	I DAC Negative Current Output.
53	IOUT+	I DAC Positive Current Output.
54	AVDD33	3.3 V Analog Supply for the DAC Cores.
55	I120	Output Current Generation Pin for the DAC Full-Scale Current. Tie a 4 k $\Omega$ resistor from this pin to the ground plane.
56	CVDD12	1.2 V Clock Supply.
	EPAD	Exposed Pad. The exposed pad must be securely connected to the ground plane.

## TERMINOLOGY

### Integral Nonlinearity (INL)

INL is the maximum deviation of the actual analog output from the ideal output, determined by a straight line drawn from zero scale to full scale.

### Differential Nonlinearity (DNL)

DNL is the measure of the variation in analog value, normalized to full scale, associated with a 1 LSB change in digital input code.

### Offset Error

Offset error is the deviation of the output current from the ideal of 0 mA. For IOUT+/QOUT+, 0 mA output is expected when all inputs are set to 0. For IOUT-/QOUT-, 0 mA output is expected when all inputs are set to 1.

### Gain Error

Gain error is the difference between the actual and ideal output span. The actual span is determined by the difference between the output when the input is at its minimum code and the output when the input is at its maximum code.

### Output Compliance Range

The output compliance range is the range of allowable voltages at the output of a current output DAC. Operation beyond the maximum compliance limits can cause either output stage saturation or breakdown, resulting in nonlinear performance.

### Temperature Drift

Temperature drift is specified as the maximum change from the ambient (25°C) value to the value at either  $T_{MIN}$  or  $T_{MAX}$ . For offset and gain drift, the drift is reported in ppm of full-scale range (FSR) per degree Celsius. For reference drift, the drift is reported in ppm per degree Celsius.

### Power Supply Rejection (PSR)

PSR is the maximum change in the full-scale output as the supplies are varied from minimum to maximum specified voltages.

### Spurious-Free Dynamic Range (SFDR)

SFDR is the difference, in decibels, between the peak amplitude of the output signal and the peak spurious signal within the dc to Nyquist frequency of the DAC. Typically, energy in this band is rejected by the interpolation filters. This specification, therefore, defines how well the interpolation filters work and the effect of other parasitic coupling paths on the DAC output.

### Signal-to-Noise Ratio (SNR)

SNR is the ratio of the rms value of the measured output signal to the rms sum of all other spectral components below the Nyquist frequency, excluding the first six harmonics and dc. The value for SNR is expressed in decibels.

### Interpolation Filter

If the digital inputs to the DAC are sampled at a multiple rate of  $f_{DATA}$  (interpolation rate), a digital filter can be constructed that has a sharp transition band near  $f_{DATA}/2$ . Images that typically appear around  $f_{DAC}$  (output data rate) can be greatly suppressed.

### Adjacent Channel Leakage Ratio (ACLR)

ACLR is the ratio in decibels relative to the carrier (dBc) between the measured power within a channel relative to its adjacent channel.

### Complex Image Rejection

In a traditional two-part upconversion, two images are created around the second IF frequency. These images have the effect of wasting transmitter power and system bandwidth. By placing the real part of a second complex modulator in series with the first complex modulator, either the upper or lower frequency image near the second IF can be rejected.

### Adjusted DAC Update Rate

The adjusted DAC update rate is defined as the DAC update rate divided by the smallest interpolating factor. For clarity on DACs with multiple interpolating factors, the adjusted DAC update rate for each interpolating factor may be given.

### Physical Lane

Physical Lane x refers to SERDINx±.

### Logical Lane

Logical Lane x refers to physical lanes after optionally being remapped by the crossbar block (Register 0x308 and Register 0x309).

### TYPICAL PERFORMANCE CHARACTERISTICS

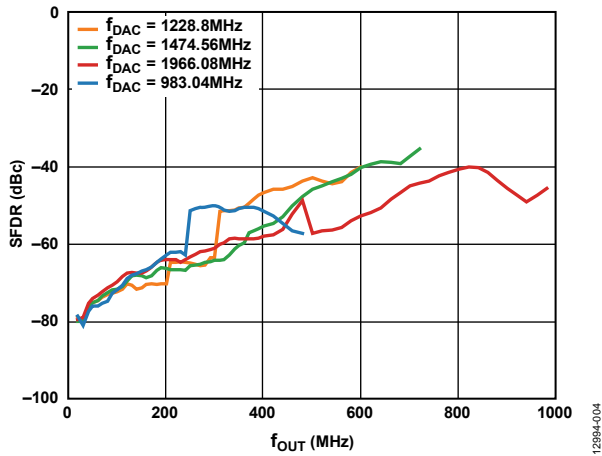

Figure 4. Single Tone (0 dBFS) SFDR vs.  $f_{OUT}$  in the First Nyquist Zone over  $f_{DAC}$

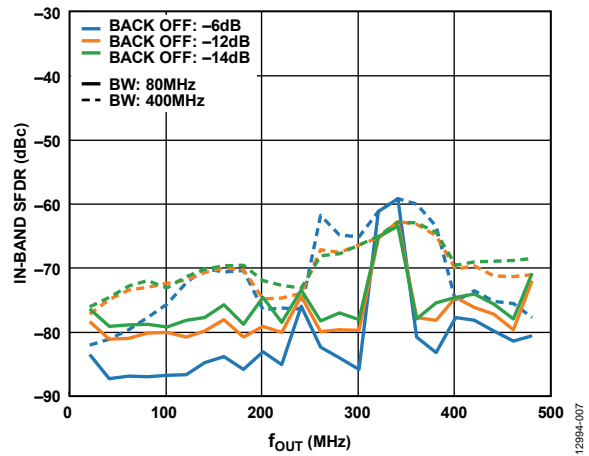

Figure 7. In-Band, Single Tone SFDR vs.  $f_{OUT}$  in 80 MHz and 400 MHz Bandwidths,  $f_{DAC} = 983.04$  MHz

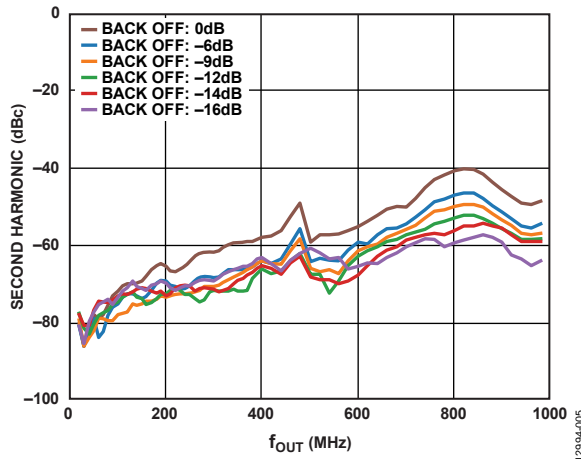

Figure 5. Single Tone Second Harmonic vs.  $f_{OUT}$  in the First Nyquist Zone over Digital Back Off,  $f_{DAC} = 1966.08$  MHz

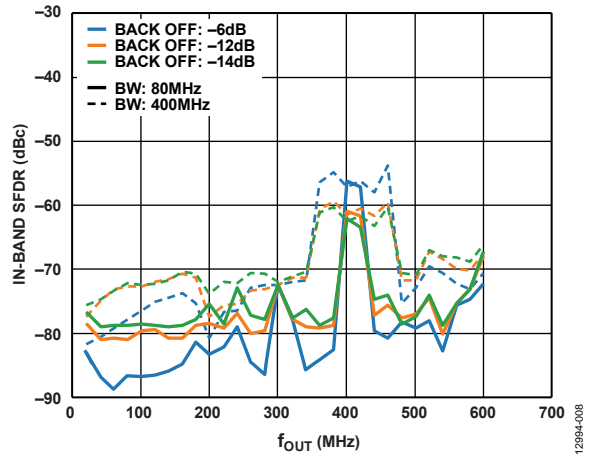

Figure 8. In-Band, Single Tone SFDR vs.  $f_{OUT}$  in 80 MHz and 400 MHz Bandwidths,  $f_{DAC} = 1228.8$  MHz

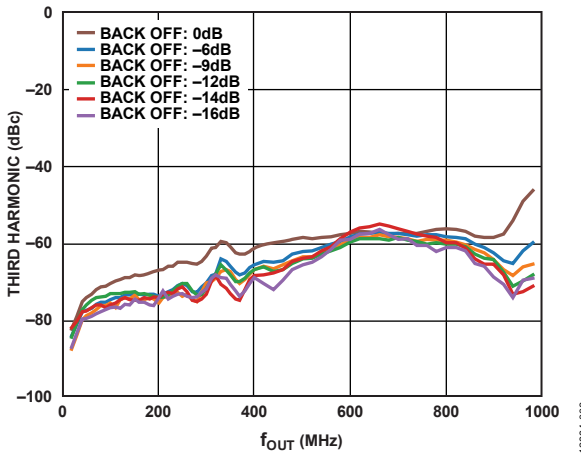

Figure 6. Single Tone Third Harmonic vs.  $f_{OUT}$  in the First Nyquist Zone over Digital Back Off,  $f_{DAC} = 1966.08$  MHz

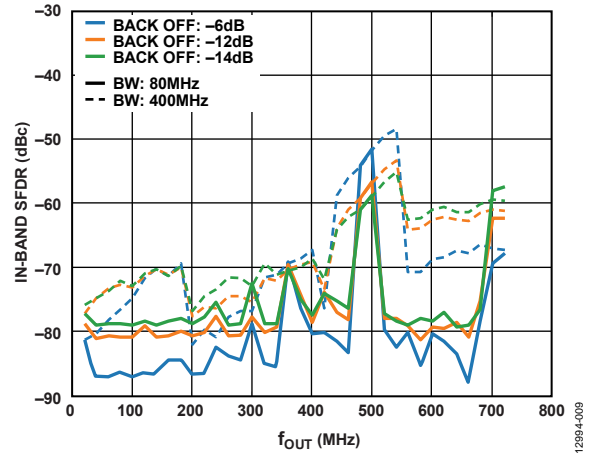

Figure 9. In-Band, Single Tone SFDR vs.  $f_{OUT}$  in 80 MHz and 400 MHz Bandwidths,  $f_{DAC} = 1474.56$  MHz

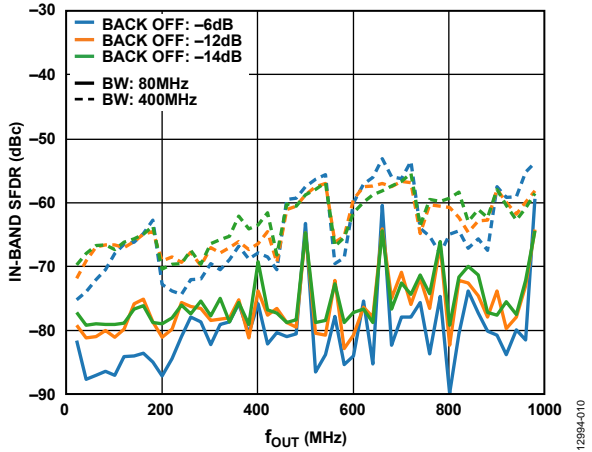

Figure 10. In-Band, Single Tone SFDR vs.  $f_{OUT}$  in 80 MHz and 400 MHz Bandwidths,  $f_{DAC} = 1966.08$  MHz

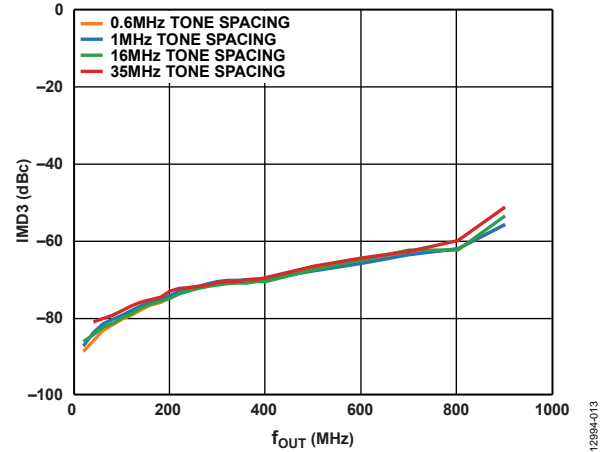

Figure 13. Two-Tone, Third-Order IMD (IMD3) vs.  $f_{OUT}$  over Tone Spacing,  $f_{DAC} = 1966.08$  MHz

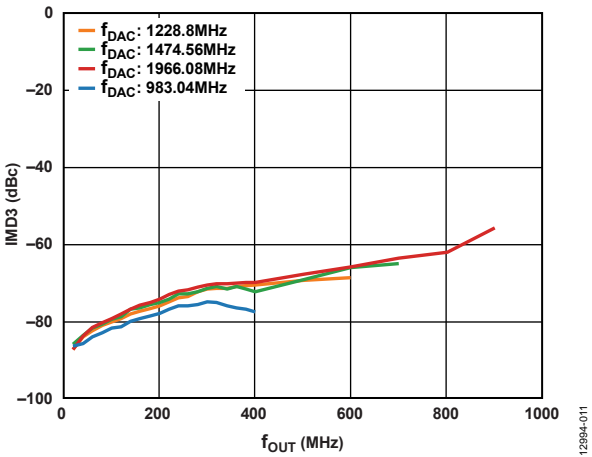

Figure 11. Two-Tone, Third-Order IMD (IMD3) vs.  $f_{OUT}$  over  $f_{DAC}$

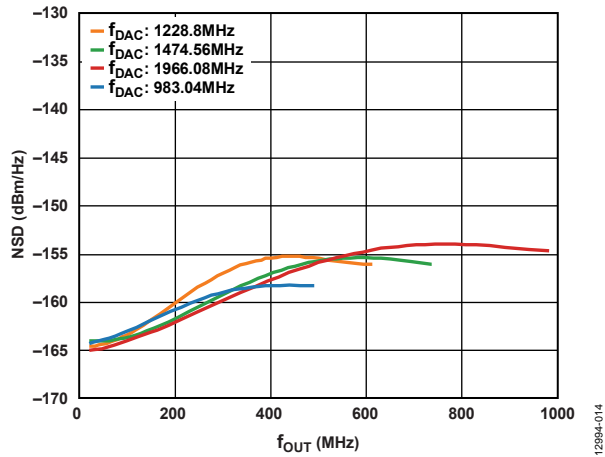

Figure 14. Single Tone (0 dBFS) NSD vs.  $f_{OUT}$  over  $f_{DAC}$

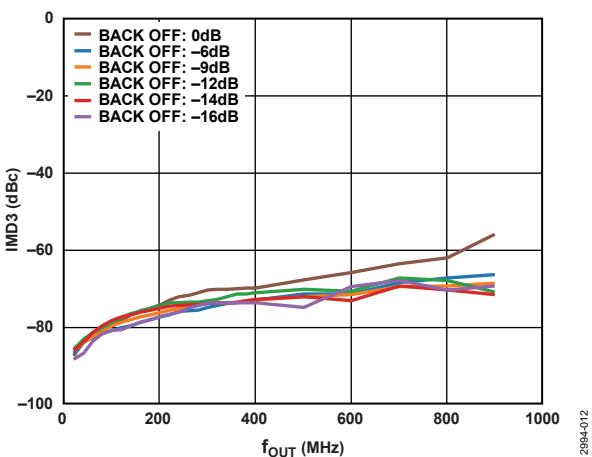

Figure 12. Two-Tone, Third-Order IMD (IMD3) vs.  $f_{OUT}$  over Digital Back Off,  $f_{DAC} = 1966.08$  MHz

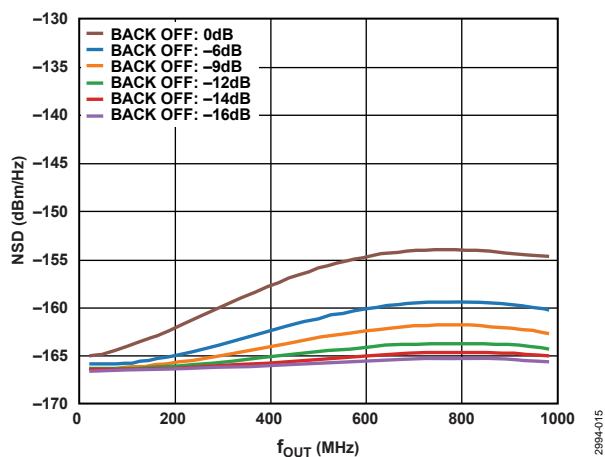

Figure 15. Single Tone NSD vs.  $f_{OUT}$  over Digital Back Off,  $f_{DAC} = 1966.08$  MHz

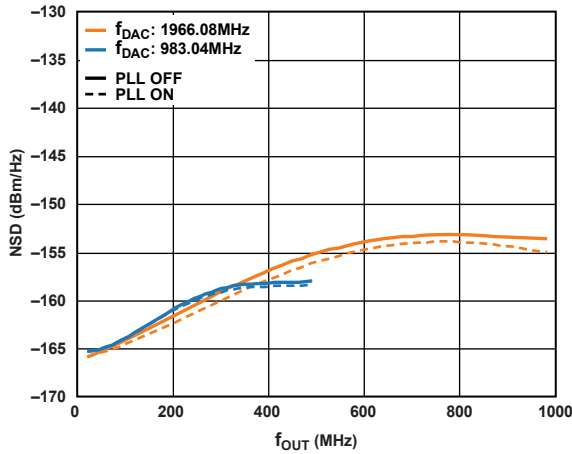

Figure 16. Single Tone NSD vs.  $f_{OUT}$ , PLL On and Off

12894-016

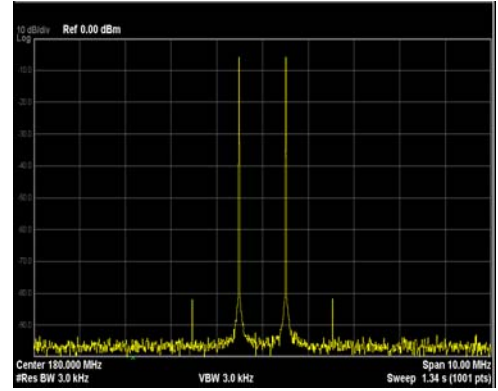

Figure 19. Two-Tone, Third-Order IMD Performance,  $IF = 180$  MHz,  $f_{DAC} = 1966.08$  MHz

12894-019

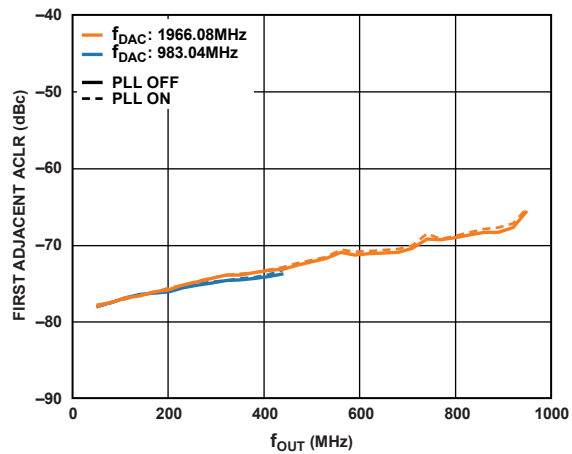

Figure 17. One-Carrier (1C) 5 MHz Bandwidth LTE, First Adjacent ACLR vs.  $f_{OUT}$ , PLL On and Off

12894-017

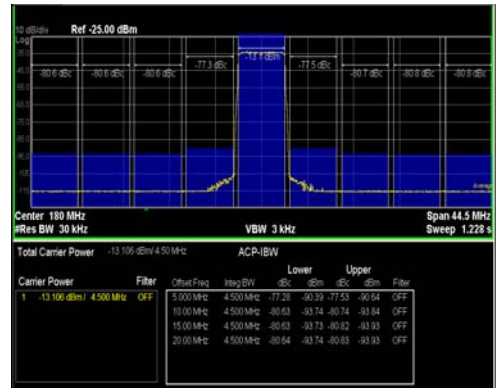

Figure 20. 1C 5 MHz Bandwidth LTE ACLR Performance,  $IF = 180$  MHz,  $f_{DAC} = 1966.08$  MHz

12894-020

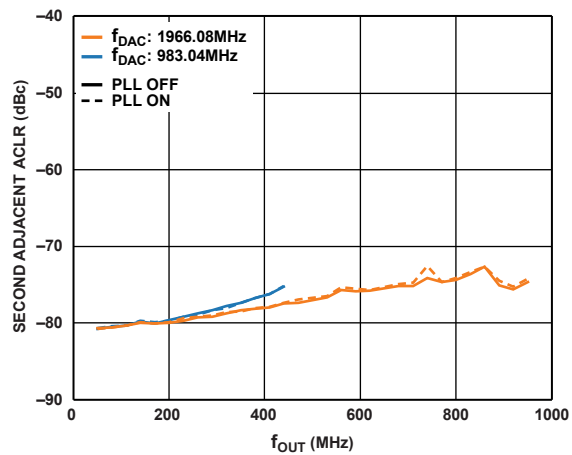

Figure 18. 1C 5 MHz Bandwidth LTE, Second Adjacent ACLR vs.  $f_{OUT}$ , PLL On and Off

12894-018



Figure 21. 1C 20 MHz Bandwidth LTE ACLR Performance,  $IF = 180$  MHz,  $f_{DAC} = 1966.08$  MHz

12894-021

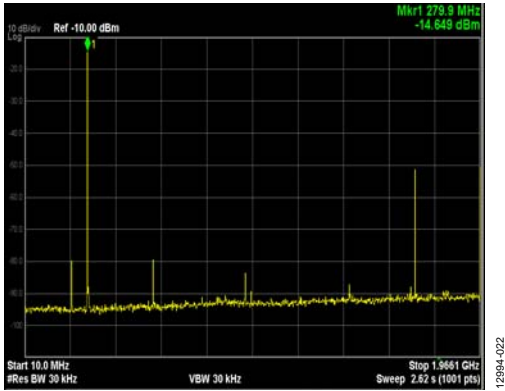

Figure 22. Single Tone,  $f_{DAC} = 1966.08$  MHz,  $f_{OUT} = 280$  MHz,  $-14$  dBFS

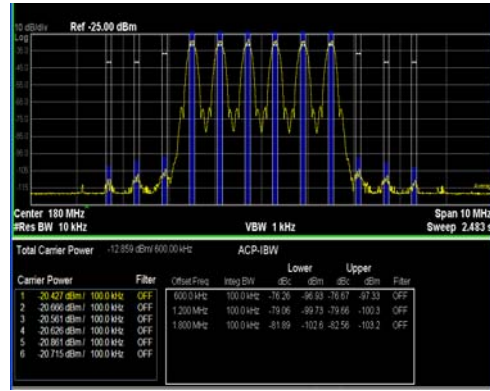

Figure 25. Six-Carrier (6C) Spaced by 600 kHz GSM Edge ACP Performance,  $IF = 180$  MHz,  $f_{DAC} = 1966.08$  MHz

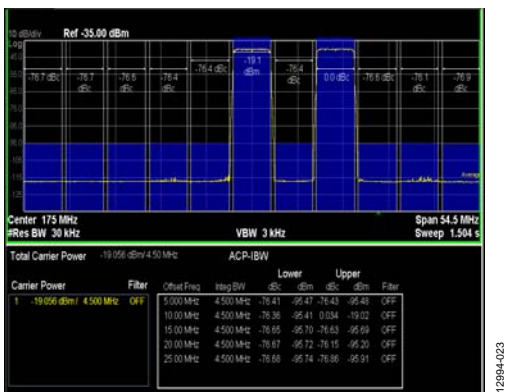

Figure 23. Two-Carrier (2C)  $2 \times 5$  MHz Bandwidth with 5 MHz Gap LTE ACLR Performance,  $IF = 180$  MHz,  $f_{DAC} = 1966.08$  MHz

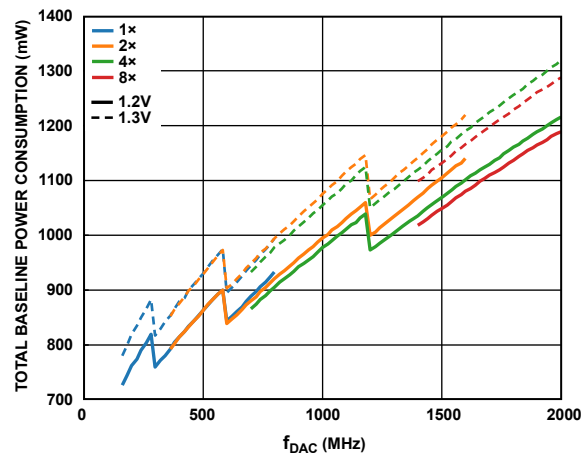

Figure 26. Total Baseline Power Consumption vs.  $f_{DAC}$  over Interpolation

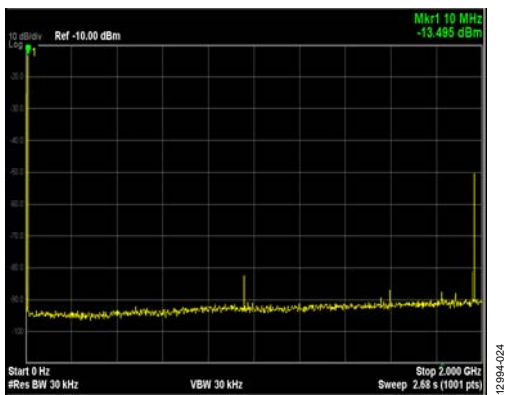

Figure 24. Single Tone SFDR,  $f_{DAC} = 1966.08$  MHz,  $4 \times$  Interpolation,  $f_{OUT} = 10$  MHz,  $-14$  dBFS

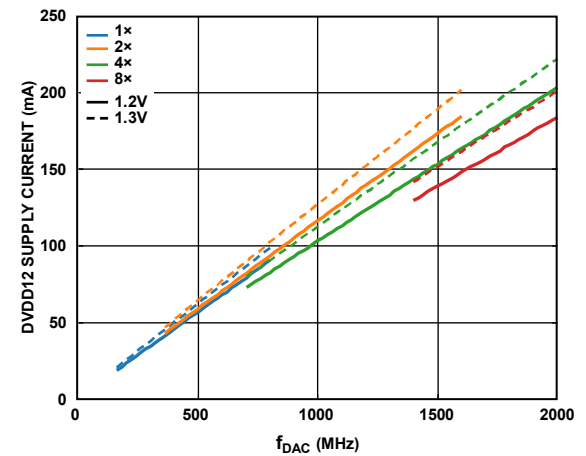

Figure 27. DVDD12 Supply Current vs.  $f_{DAC}$  over Interpolation

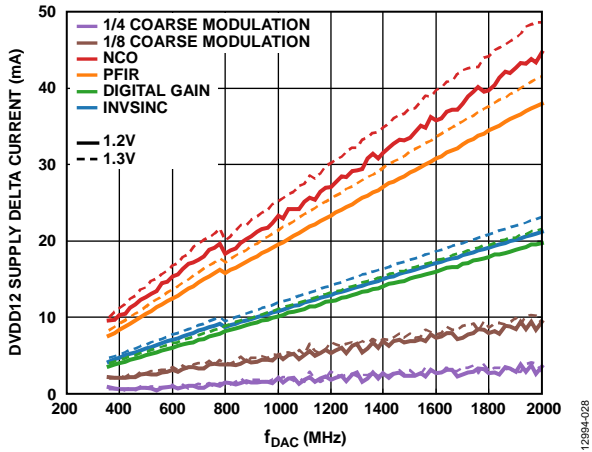

Figure 28. DVDD12 Supply Delta Current vs.  $f_{DAC}$  over Digital Functions

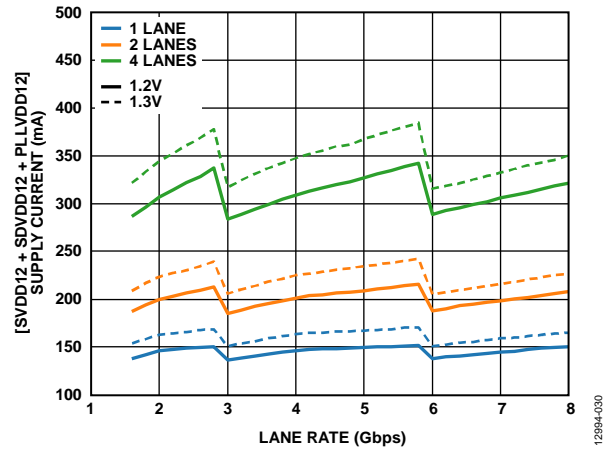

Figure 30. Total SERDES Supply Current (SVDD12, SDVDD12, PLLVDD12) vs. Lane Rate; One, Two, and Four Lanes

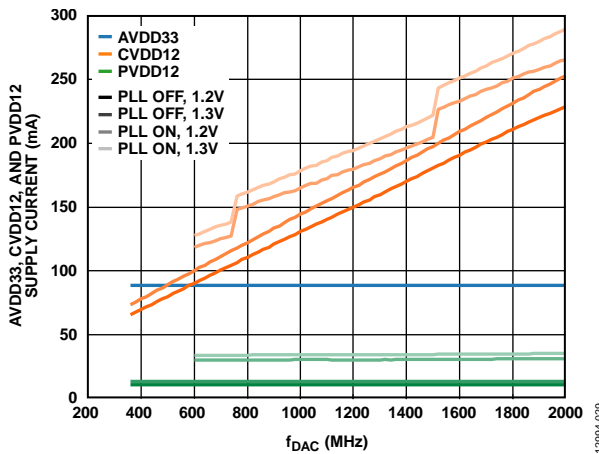

Figure 29. AVDD33, CVDD12, PVDD12 Supply Current vs.  $f_{DAC}$

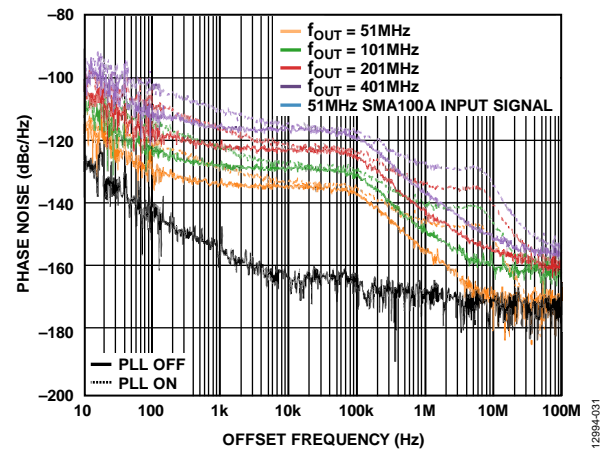

Figure 31. Single Tone Phase Noise vs. Offset Frequency at Four  $f_{OUT}$  Values and with an SMA100A Signal Generator,  $f_{DAC} = 1.96608$  GHz, PLL On and Off

## THEORY OF OPERATION

The [AD9152](#) is a 16-bit, dual DAC with a SERDES interface. Figure 2 shows a detailed functional block diagram of the [AD9152](#). Four high speed serial lanes carry data at a maximum speed of 12.38 Gbps, and a 1.238 GSPS input data rate to the DACs. Compared to either LVDS or CMOS interfaces, the SERDES interface simplifies pin count, board layout, and input clock requirements to the device.

The clock for the input data is derived from the device clock (required by the JESD204B specification). This device clock can be sourced with a PLL reference clock used by the on-chip PLL to generate a DAC clock, a high fidelity direct external DAC sampling clock, or a 2× DAC frequency RF clock. The device can be configured to operate in one-, two-, or four-lane modes, depending on the required input data rate.

The digital datapath of the [AD9152](#) offers four interpolation modes (1×, 2×, 4×, and 8×) through three half-band filters with a maximum DAC sample rate of 2.25 GSPS. An inverse sinc filter compensates for sinc related roll-off. The PFIR filter compensates the gain over frequency in a more flexible way.

The [AD9152](#) DAC cores provide a fully differential current output with a nominal full-scale current of 20 mA. The full-scale

current,  $I_{OUTFS}$ , is user adjustable to between 4.04 mA and 20.22 mA, typically. The differential current outputs are complementary and are optimized for easy integration with the Analog Devices [ADRF6720](#) AQM. The [AD9152](#) is capable of multichip synchronization that can both synchronize multiple DACs and establish a constant and deterministic latency (latency locking) path for the DACs. The latency for each of the DACs remains constant from link establishment to link establishment. An external alignment (SYSREF±) signal makes the [AD9152](#) Subclass 1 compliant. Several modes of SYSREF± signal handling are available for use in the system.

An SPI configures the various functional blocks and monitors their statuses. The various functional blocks and the data interface must be set up in a specific sequence for proper operation (see the Device Setup Guide section). Simple SPI initialization routines set up the JESD204B link and are included in the evaluation board package. The following sections describe the various blocks of the [AD9152](#) in greater detail. Descriptions of the JESD204B interface, control parameters, and various registers to set up and monitor the device are provided. The recommended start-up routine reliably sets up the data link.

## SERIAL PORT OPERATION

The serial port is a flexible, synchronous serial communications port that allows easy interfacing with many industry-standard microcontrollers and microprocessors. The serial input/output is compatible with most synchronous transfer formats, including both the Motorola SPI and Intel® SSR protocols. The interface allows read/write access to all registers that configure the AD9152. MSB first or LSB first transfer formats are supported. The serial port interface is a 4-wire or a 3-wire (by default) interface in which the input and output share a single-pin input/output (SDIO).

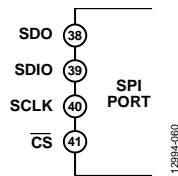

Figure 32. Serial Port Interface Pins

There are two phases to a communication cycle with the AD9152. Phase 1 is the instruction cycle (the writing of an instruction byte into the device), coincident with the first 16 SCLK rising edges. The instruction word provides the serial port controller with information regarding the data transfer cycle, Phase 2 of the communication cycle. The Phase 1 instruction word defines whether the upcoming data transfer is a read or write, along with the starting register address for the following data transfer.

A logic high on the  $\overline{CS}$  pin followed by a logic low resets the serial port timing to the initial state of the instruction cycle. From this state, the next 16 rising SCLK edges represent the instruction bits of the current input/output operation.

The remaining SCLK edges are for Phase 2 of the communication cycle. Phase 2 is the actual data transfer between the device and the system controller. Phase 2 of the communication cycle is a transfer of one or more data bytes. Eight  $\times$  N SCLK cycles are needed to transfer N bytes during the transfer cycle. Registers change immediately upon writing to the last bit of each transfer byte, except for the frequency tuning word (FTW) and the numerically controlled oscillator (NCO) phase offsets, which change only when the frequency tuning word (FTW) FTW\_UPDATE\_REQ bit (Register 0x113, Bit 0) is set.

### DATA FORMAT

The instruction byte contains the information shown in Table 13.

Table 13. Serial Port Instruction Word

I15 (MSB)	I[14:0]
R/W	A[14:0]

R/W, Bit 15 of the instruction word, determines whether a read or a write data transfer occurs after the instruction word write. Logic 1 indicates a read operation, and Logic 0 indicates a write operation.

A14 to A0, Bit 14 to Bit 0 of the instruction word, determine the register that is accessed during the data transfer portion of the communication cycle. For multibyte transfers, [A14:0] is the starting address. The remaining register addresses are generated by the device based on the address increment bits (Register 0x000, Bit 5 and Bit 2). If the address increment bits are set high, multibyte SPI writes start on A[14:0] and increment by 1 every 8 bits sent/received. If the address increment bits are set to 0, the address decrements by 1 every 8 bits.

### SERIAL PORT PIN DESCRIPTIONS

#### Serial Clock (SCLK)

The serial clock pin synchronizes data to and from the device and runs the internal state machines. The maximum frequency of SCLK is 10 MHz. All data input is registered on the rising edge of SCLK. All data is driven out on the falling edge of SCLK.

#### Chip Select ( $\overline{CS}$ )

An active low input starts and gates a communication cycle. It allows more than one device to be used on the same serial communications lines. The SDIO pin goes to a high impedance state when this input is high. During the communication cycle, chip select must stay low.

#### Serial Data Input/Output (SDIO)

This pin is a bidirectional data line. In 4-wire mode, this pin acts as the data input and SDO acts as the data output.

### SERIAL PORT OPTIONS

The serial port can support both MSB first and LSB first data formats. This functionality is controlled by the LSB first bits (Register 0x000, Bit 6 and Bit 1). The default is MSB first (the LSB first bits = 0).

When the LSB first bits = 0 (MSB first), the instruction and data bits are written from MSB to LSB. R/W is followed by A[14:0] as the instruction word, and D[7:0] is the data-word. When the LSB first bits = 1 (LSB first), the opposite is true. A[0:14] is followed by R/W, which is subsequently followed by D[0:7].

The serial port supports a 3-wire or 4-wire interface. When the SDO active bits = 1 (Register 0x000, Bit 4 and Bit 3), a 4-wire interface with a separate input pin (SDIO) and output pin (SDO) is used. When the SDO active bits = 0, the SDO pin is unused and the SDIO pin is used for both input and output.

Multibyte data transfers can be performed as well. This is achieved by holding the  $\overline{CS}$  pin low for multiple data transfer cycles (eight SCLKs) after the first data transfer word following the instruction cycle. The first eight SCLKs following the instruction cycle read from or write to the register provided in the instruction cycle. For each additional eight SCLK cycles, the address is either incremented or decremented and the read/write occurs on the new register. The direction of the address can be set using the address increment bits (Register 0x000, Bit 5 and Bit 2). When the address increment bits are 1, the multicycle addresses are incremented. When the address increment bits are 0, the addresses are decremented. A new write cycle can always be initiated by bringing  $\overline{CS}$  high and then low again.

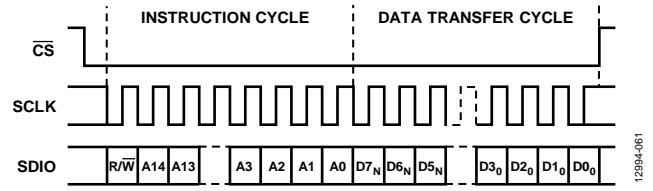

Figure 33. Serial Register Interface Timing, MSB First, Register 0x000, Bit 5 and Bit 2 = 0

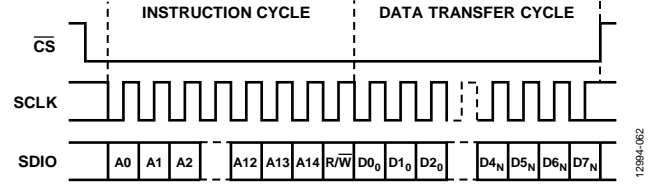

Figure 34. Serial Register Interface Timing, LSB First, Register 0x000, Bit 5 and Bit 2 = 1

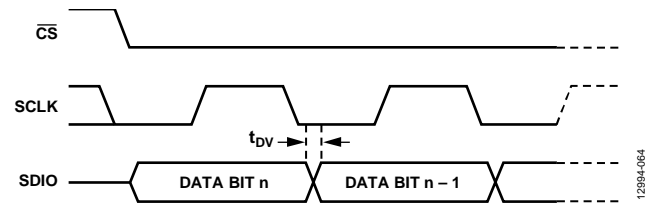

Figure 35. Timing Diagram for Serial Port Register Read

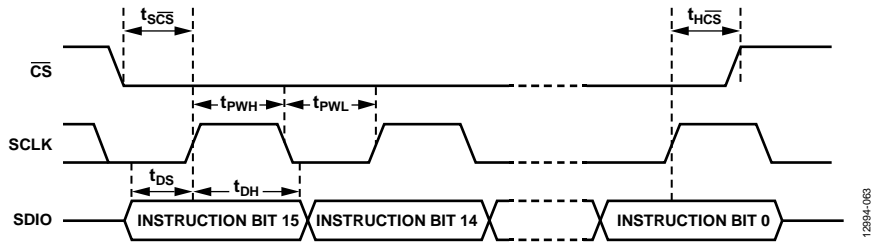

Figure 36. Timing Diagram for Serial Port Register Write

## CHIP INFORMATION

Register 0x003 to Register 0x006 contain chip information, as shown in Table 14.

**Table 14. Chip Information**

<b>Information</b>	<b>Description</b>
Chip Type	Register 0x003. The product type is high speed DAC, which is represented by a code of 0x04.
Product ID	8 MSBs in Register 0x005 and 8 LSBs in Register 0x004. The product ID is 0x9152.
Device Revision	Register 0x006, Bits[4:0]. The device revision is 0x8.

## DEVICE SETUP GUIDE

### OVERVIEW

The sequence of steps to properly set up the AD9152 is as follows:

1. Set up the SPI interface, power up necessary circuit blocks, make the required writes to the configuration registers, and set up the DAC clocks (see Step 1: Start Up the DAC).
2. Set the digital features (see Step 2: Digital Datapath).
3. Set up the JESD204B links (see Step 3: Transport Layer).
4. Set up the physical layer of the SERDES interface (see Step 4: Physical Layer).
5. Set up the data link layer of the SERDES interface (see Step 5: Data Link Layer).
6. Check for errors (see Step 6: Optional Error Monitoring).
7. Optionally, enable any needed features as described in Step 7: Optional Features.

A specific working start-up sequence example is given in the Example Start-Up Sequence section.

The register writes listed in Table 15 to Table 23 give the register writes necessary to set up the AD9152. Consider printing this setup guide and filling in the Value column with appropriate variable values for the conditions of the desired application.

The notation 0x indicates register settings that the user must fill in. To fill in the unknown register values, select the correct settings for each variable listed in the Variable column. The Description column describes how to set variables or provides a link to a section where this is described. Register settings with specified values are fixed settings to be used in all cases. A variable is noted by concatenating multiple terms. For example, PdDACs is a variable that corresponds to the value determined for Register 0x011, Bits[6:5].

### STEP 1: START UP THE DAC

This section describes how to set up the SPI interface, power up necessary circuit blocks, write to the required configuration registers, and set up the DAC clocks.

**Table 15. Power-Up and DAC Initialization Settings**

Addr.	Bit No.	Value <sup>1</sup>	Variable	Description
0x000		0xBD		Soft reset.
0x000		0x3C		Deassert reset, set 4-wire SPI.
0x011		0x		
	7	0		Power up band gap.
	[6:5]		PdDACs	PdDACs = 0 if both DACs are used. If not, see the DAC Power-Down Setup section.
	4	0		Power up digital clocks.
	[3:2]		PdCLKs	PdCLKs = 0 if both DACs are used.
	1	0		Power up the PCLK.
	0	0		Power up the clock receiver.
0x080		0x		
	2		DUTY_EN	DUTY_EN = 1 if using the duty function.
0x081		0x		
	4		PdSysref	PdSysref = 0x0 for Subclass 1. PdSysref = 0x1 for Subclass 0. See the Subclass Setup section.
0x1CD <sup>2</sup>		0xD8		Band gap configuration.

<sup>1</sup> 0x denotes a register value that the user must fill in. See the Variable and Description columns for information on selecting the appropriate register value.

<sup>2</sup> Register 0x1CD must be set to the recommended value and does not appear in the register map.

The following registers must be written to and values changed from default for the device to work correctly and must be written after any soft reset, hard reset, or power-up occurs. All registers in Table 16 do not appear in the register map.

**Table 16. Required SERDES PLL Register Settings**

Address	Value <sup>1</sup>	Description
0x284	0x62	SERDES PLL configuration
0x285	0xC9	SERDES PLL configuration
0x286	0xE	SERDES PLL configuration
0x287	0x12	SERDES PLL configuration
0x28A	0x	See Table 36
0x28B	0x0	SERDES PLL configuration
0x290	0x89	SERDES PLL configuration
0x291	0x	See Table 36
0x294	0x24	SERDES PLL configuration
0x296	0x	See Table 36
0x297	0xD	SERDES PLL configuration
0x299	0x2	SERDES PLL configuration
0x29A	0x8E	SERDES PLL configuration
0x29C	0x2A	SERDES PLL configuration
0x29F	0x7E	SERDES PLL configuration
0x2A0	0x6	SERDES PLL configuration

<sup>1</sup> 0x denotes a register value that the user must fill in. See the Variable and Description columns for information on selecting the appropriate register value.

If using the optional DAC PLL, also set the registers in Table 17 and Table 18. The registers in Table 17 optimize the performance of the SERDES PLL and must be set to the fixed value as required. Some registers in Table 17 do not appear in the register map.

Table 17. Required DAC PLL Configurations

Address	Value	Description
0x08D	0x7B	DAC PLL configuration
0x1B0	0x0	DAC PLL configuration
0x1B9	0x24	DAC PLL configuration
0x1BC	0xD	DAC PLL configuration
0x1BE	0x2	DAC PLL configuration
0x1BF	0x8E	DAC PLL configuration
0x1C0	0x2A	DAC PLL configuration
0x1C4	0x7E	DAC PLL configuration
0x1C1	0x2C	DAC PLL configuration

Table 18. Optional DAC PLL Configuration Procedure

Addr.	Value <sup>1</sup>	Variable	Description
0x08B	0x	LODivMode	See the DAC PLL Setup section
0x08C	0x	RefDivMode	See the DAC PLL Setup section
0x085	0x	BCount	See the DAC PLL Setup section
0x1B6	0x	LookUpVals	See Table 73
0x1B5	0x		See Table 73
0x1BB	0x	LookUpVals	See Table 73
0x1B4	0x78		Optimal DAC PLL VCO settings
0x1C5	0x		See Table 73
0x08A	0x12		Optimal DAC PLL VCO settings
0x087	0x62		Optimal DAC PLL loop filter settings
0x088	0xC9		Optimal DAC PLL loop filter settings
0x089	0x0E		Optimal DAC PLL loop filter settings
0x083	0x10		Enable the DAC PLL <sup>2</sup>

<sup>1</sup> 0x denotes a register value that the user must fill in. See the Variable and Description columns for information on selecting the appropriate register value.

<sup>2</sup> Verify that Register 0x084, Bit 1 reads back 1 after enabling the DAC PLL to indicate that the DAC PLL has locked.

## STEP 2: DIGITAL DATAPATH

This section describes which interpolation filters to use and sets the data format being used. Additional digital features are available including fine and coarse modulation, digital gain scaling, and an inverse sinc filter used to improve pass-band flatness. Table 23 provides further details on the feature blocks available.

Table 19. Digital Datapath Settings

Addr.	Bit No.	Value <sup>1</sup>	Variable	Description
0x112		0x	InterpMode	Select interpolation mode; see the Interpolation section.
0x110		0x		
	7		DataFmt	DataFmt = 0 if twos complement; DataFmt = 1 if unsigned binary.

<sup>1</sup> 0x denotes a register value that the user must fill in. See the Variable and Description columns for information on selecting the appropriate register value.

## STEP 3: TRANSPORT LAYER

This section describes how to set up the JESD204B links. The parameters are determined by the desired JESD204B operating mode. See the JESD204B Setup section for details.

Table 20. Transport Layer Settings

Addr.	Bit No.	Value <sup>1</sup>	Variable	Description
0x200		0x00		Power up the interface.
0x201		0x	UnusedLanes	See the JESD204B Setup section.
0x300		0x		
	6		ChecksumMode	See the JESD204B Setup section.
0x450		0x	DID	Set DID to match the device ID sent by the transmitter.
0x451		0x	BID	Set BID to match the bank ID sent by the transmitter.
0x452		0x	LID	Set LID to match the lane ID sent by the transmitter.
0x453		0x		
	7		Scrambling	See the JESD204B Setup section.
	[4:0]		L – 1 <sup>2</sup>	See the JESD204B Setup section.
0x454		0x	F – 1 <sup>2</sup>	See the JESD204B Setup section.
0x455		0x	K – 1 <sup>2</sup>	See the JESD204B Setup section.
0x456		0x	M – 1 <sup>2</sup>	See the JESD204B Setup section.
0x457		0x	N – 1 <sup>2</sup>	N = 16.
0x458		0x		
	5		Subclass	See the JESD204B Setup section.
	[4:0]		Np – 1 <sup>2</sup>	Np = 16.
0x459		0x		
	5		JESDVer	JESDVer = 1 for JESD204B, JESDVer = 0 for JESD204A.
	[4:0]		S – 1 <sup>2</sup>	See the JESD204B Setup section.
0x45A		0x		
	7		HD	See the JESD204B Setup section.
	[4:0]		CF	CF must equal 0.
0x45D		0x	Lane0Checksum	See the JESD204B Setup section.
0x46C		0x	Lanes	Deskew lanes.
0x476		0x	F	See the JESD204B Setup section.
0x47D		0x	Lanes	Enable lanes. See the JESD204B Setup section.

<sup>1</sup> 0x denotes a register value that the user must fill in. See the Variable and Description columns for information on selecting the appropriate register value.

<sup>2</sup> This JESD204B link parameter is programmed in n – 1 notation as noted. For example, if the setup requires L = 4 (4 lanes per link), program L – 1 or 3 into Register 0x453, Bits[4:0].

**STEP 4: PHYSICAL LAYER**

This section describes how to set up the physical layer of the SERDES interface. In this section, the input termination settings are configured along with the CDR sampling and SERDES PLL.

**Table 21. Device Configurations and Physical Layer Settings**

Addr.	Bit No.	Value <sup>1</sup>	Variable	Description
0x2A7		0x01		Autotune PHY setting.
0x314		0x01		SERDES SPI configuration.
0x230		0x		
	5		Halfrate	Set up the CDR; see the SERDES Clocks Setup section.
	[4:2]	0x2		SERDES PLL default configuration.
	1		OvSmp	Set up the CDR; see the SERDES Clocks Setup section.
	0	1		SYNCOU $\pm$ swing VOD is set to 350 mV.
0x206		0x00		Reset the CDR.
0x206		0x01		Release CDR reset.
0x289		0x		
	2	1		SERDES PLL configuration.
	[1:0]		PLLDiv	Set the CDR oversampling for PLL; see the SERDES Clocks Setup section.
0x280		0x01		Enable the SERDES PLL. <sup>2</sup>
0x268		0x		
	[7:6]		EqMode	See the Equalization Mode Setup section.
	[5:0]	0x22		Required value (default).

<sup>1</sup> 0x denotes a register value that the user must fill in. See the Variable and Description columns for information on selecting the appropriate register value.

<sup>2</sup> Verify that Register 0x281, Bit 0 reads back 1 after enabling the SERDES PLL to indicate that the SERDES PLL has locked.

**STEP 5: DATA LINK LAYER**

This section describes how to set up the data link layer of the SERDES interface. This section deals with SYSREF processing, setting deterministic latency, and establishing the link.

**Table 22. Data Link Layer Settings**

Addr.	Bit No.	Value <sup>1</sup>	Variable	Description
0x301		0x	Subclass	See the JESD204B Setup section.
0x304		0x	LMFCDeI	See the Link Latency Setup section.
0x306		0x	LMFCVAr	See the Link Latency Setup section.
0x03A		0x01		Set sync mode = one shot sync; see the Syncing LMFC Signals section for other sync options.
0x03A		0x81		Enable the sync machine.
0x03A		0xC1		Arm the sync machine.
SYSREF $\pm$				If Subclass = 1, ensure that at least one SYSREF $\pm$ edge is sent to the device. <sup>2</sup>
0x308 to 0x309		0x	XBarVals	If remapping lanes, set up cross-bar; see the Crossbar Setup section.
0x334		0x	InvLanes	Invert the polarity of the desired logical lanes. Bit x of InvLanes must be a 1 for each Logical Lane x to invert.
0x300		0x		Enable the link.
	6		ChkSmMd	See the JESD204B Setup section.
	0	1		Enable the link.

<sup>1</sup> 0x denotes a register value that the user must fill in. See the Variable and Description columns for information on selecting the appropriate register value.

<sup>2</sup> Verify that Register 0x03B, Bit 3 reads back 1 after sending at least one SYSREF $\pm$  edge to the device to indicate that the LMFC sync machine has properly locked.

**STEP 6: OPTIONAL ERROR MONITORING**

For JESD204B error monitoring, see the JESD204B Error Monitoring section. For other error checks, see the Interrupt Request Operation section.

**STEP 7: OPTIONAL FEATURES**

A number of optional features can be enabled. Table 22 provides links to the sections describing each feature.

**Table 23. Optional Features**

Feature	Default	Description
Digital Modulation	Off	Modulates the data with a desired carrier. See the Digital Modulation section.
Inverse Sinc	Off	Improves pass-band flatness. See the Inverse Sinc section.
Digital Gain	0 dB	Multiplies data by a factor. Can compensate inverse sinc usage or balance I/Q amplitude. See the Digital Gain section.
Phase Adjust	Off	Used to balance I/Q phase. See the Phase Adjust section.
DC Offset	Off	Used to cancel LO leakage. See the DC Offset section.
Coarse Group Delay Adjustment	0	Used to control overall latency. See the Coarse Group Delay Adjustment section.
Downstream Protection	Off	Used to protect downstream components. See the Downstream Protection section.

## DAC PLL SETUP

This section explains how to select appropriate LODivMode, RefDivMode, and BCount values in the Device Setup Guide section. These parameters depend on the desired DAC clock frequency ( $f_{DAC}$ ) and DAC reference clock frequency ( $f_{REF}$ ). When using the DAC PLL, the reference clock signal is applied to the REFCLK± differential pins (Pin 3 and Pin 4).

**Table 24. DAC PLL LODivMode Settings**

DAC Frequency Range (MHz)	LO_DIV_MODE, Register 0x08B, Bits[1:0]
1500 to 2250	1
750 to 1500	2
420 to 750	3

**Table 25. DAC PLL RefDivMode Settings**

DAC PLL Reference Frequency ( $f_{REF}$ ) (MHz)	Divide by Factor (RefDivFactor)	REF_DIV_MODE, Register 0x08C, Bits[2:0]
80 to 160	2	1
160 to 320	4	2
320 to 640	8	3
640 to 1000	16	4

The VCO frequency ( $f_{VCO}$ ) is related to the DAC clock frequency according to the following equation:

$$f_{VCO} = f_{DAC} \times 2^{LODivMode + 1}$$

where  $6 \text{ GHz} \leq f_{VCO} \leq 12 \text{ GHz}$ .

BCount must be between 6 and 127 and is calculated based on  $f_{DAC}$  and  $f_{REF}$  as follows:

$$BCount = \text{floor}((f_{DAC}) / (2 \times f_{REF} / \text{RefDivFactor}))$$

where  $\text{RefDivFactor} = 2^{\text{RefDivMode}}$  (see Table 25).

Finally, to finish configuring the DAC PLL, set the VCO control registers up as described in Table 73 based on the VCO frequency ( $f_{VCO}$ ).

For more information on the DAC PLL, see the DAC Input Clock Configurations section.

## INTERPOLATION

The transmit path can use zero to three cascaded interpolation filters, which each provide a 2× increase in output data rate and a low-pass function. Table 26 shows the different interpolation modes and the respective usable bandwidth along with the maximum  $f_{DATA}$  rate attainable when the power supply is 1.2 V.

**Table 26. Interpolation Modes and Their Usable Bandwidth**

Interpolation Mode	InterpMode	Usable Bandwidth	Maximum $f_{DATA}$ (MHz)
1× (bypass)	0x00	$f_{DATA}$	1238 (JESD204B limited)
2×	0x01	$0.4 \times f_{DATA}$	1125
4×	0x02	$0.4 \times f_{DATA}$	562.5
8×	0x03	$0.4 \times f_{DATA}$	281.25

The usable bandwidth is defined for 1×, 2×, 4×, and 8× modes as the frequency band over which the filters have a pass-band ripple of less than ±0.001 dB and an image rejection of greater than 85 dB. For more information, see the Interpolation Filters section.

## JESD204B SETUP

This section explains how to select a JESD204B operating mode for a desired application. This in turn defines appropriate values for CheckSumMode, UnusedLanes, DualLink, CurrentLink, Scrambling, L, F, K, M, N, Np, Subclass, S, HD, Lane0Checksum, and Lanes needed for the Device Setup Guide section.

Note that DualLink, Scrambling, L, F, K, M, N, Np, S, HD, and Subclass must be set the same on the transmit side.

For a summary of how a JESD204B system works and what each parameter means, see the JESD204B Serial Data Interface section.

### Available Operating Modes

**Table 27. JESD204B Operating Modes (Single Link)**

Parameter	Mode					
	4	5	6	7	9	10
M (Converter Count)	2	2	2	2	1	1
L (Lane Count)	4	4	2	1	2	1
S ((Samples per Converter) per Frame)	1	2	1	1	1	1
F ((Octets per Frame) per Lane)	1	2	2	4	1	2

For a particular application, the number of converters to use (M) and the  $f_{DATA}$  (DataRate) are known. The LaneRate and number of lanes (L) can be traded off as follows:

$$\text{DataRate} = (\text{DACRate}) / (\text{InterpolationFactor})$$

$$\text{LaneRate} = (20 \times \text{DataRate} \times M) / L$$

where LaneRate is between 1.44 Gbps and 12.38 Gbps at 1.3 V.

Octets per frame per lane (F) and samples per convertor per frame (S) define how the data is packed. If F = 1, the high density setting must be set to one (HD = 1). Otherwise, set HD = 0.

Converter resolution and bits per sample (N and Np) must both be set to 16. Frames per multiframe (K) must be set to 32 for Mode 4 and Mode 9. Other modes may use either K = 16 or K = 32.

### Scrambling

Scrambling is a feature that makes the spectrum of the link data independent. This avoids spectral peaking and provides some protection against data dependent errors caused by frequency selective effects in the electrical interface. Set to 1 if scrambling is being used, or to 0 if it is not.

### Subclass

Subclass determines whether the latency of the device is deterministic, meaning it requires an external synchronization signal. See the Subclass Setup section for more information.

### CurrentLink

Set CurrentLink to 0 to configure Link 0.

## Lanes

Use Lanes to enable and deskew particular lanes in two thermometer coded registers.

$$\text{Lanes} = (2^L) - 1$$

## UnusedLanes

UnusedLanes is used to turn off unused circuit blocks to save power. Each physical lane that is not being used (SERDIN $x\pm$ ) must be powered off by writing a 1 to the corresponding bit of Register 0x201.

For example, if using Mode 6 in single link mode and sending data on SERDIN0 $\pm$  and SERDIN2 $\pm$ , set UnusedLanes = 0x0A to power off Physical Lane 1 and Physical Lane 3.

## ChecksumMode

ChecksumMode must match the checksum mode used on the transmit side. If the checksum used is the sum of the fields in the link configuration table, CheckSumMode = 0. If summing the registers containing the packed link configuration fields, CheckSumMode = 1. For more information on the how to calculate the two checksum modes, see the Lane0Checksum section.

## Lane0Checksum

Lane0Checksum may be used for error checking purposes to ensure that the transmitter is set up as expected.

If CheckSumMode = 0, the checksum is the lower 8 bits of the sum of the L – 1, M – 1, K – 1, N – 1, N $p$  – 1, S – 1, Scrambling, HD, Subclass, and JESDVer variables.

If CheckSumMode = 1, Lane0Checksum is the lower 8 bits of the sum of Register 0x450 to Register 0x45A. Select whether to sum by fields or by registers, matching the setting on the transmitter.

## DAC Power-Down Setup

As described in the Step 1: Start Up the DAC section, PdDACs must be set to 0 if both converters are being used. If only one of the converters is being used, the unused converter must be powered down. Table 28 can be used to determine which DAC is powered down based on the number of converters (M) and which converter to use (I DAC or Q DAC).

**Table 28. DAC Power-Down Configuration Settings**

M (Converters per Link)	DACs to Power Down		PdCLKs
	I	Q	
1	0	1	0b01
1	1	0	0b10
2	0	0	0b00

## PdClocks

If one of the two DACs is powered down, the clock for that DAC can be powered down. If the I DAC is powered down, PdClocks = 0b10. If the Q DAC is powered down, PdClocks = 0b01.

## SERDES CLOCKS SETUP

This section describes how to select the appropriate Halfrate, OvSmp, and PLLDiv settings in the Device Setup Guide section. These parameters depend solely on the lane rate (the lane rate is established in the JESD204B Setup section).

**Table 29. SERDES Lane Rate Configuration Settings**

Lane Rate (Gbps)	Halfrate	OvSmp	PLLDiv
1.44 to 3.09	0	1	2
2.88 to 6.19	0	0	1
5.75 to 12.38	1	0	0

Halfrate and OvSmp set how the clock detect and recover (CDR) circuit samples. See the SERDES PLL section for an explanation of how that circuit blocks works and the role of PLLDiv in the block.

## EQUALIZATION MODE SETUP

Set EqMode = 1 for a low power setting. Select this mode if the insertion loss in your printed circuit board (PCB) is less than 12 dB. For insertion losses greater than 12 dB, but less than 17.5 dB, set EqMode = 0. More details can be found in the Equalization section.

## LINK LATENCY SETUP

This section describes the steps necessary to guarantee multichip deterministic latency in Subclass 1 and guarantee synchronization of links within a device in Subclass 0. Use this section to fill in LMFCDel, LMFCVar, and Subclass in the Device Setup Guide section. For more information, see the Syncing LMFC Signals section.

### Subclass Setup

The AD9152 supports JESD204B Subclass 1 and Subclass 0 operation.

#### Subclass 1

Subclass 1 mode achieves deterministic latency and allows the synchronization of links to within the limits listed in Table 7. It requires an external SYSREF $\pm$  signal that is accurately phase aligned to the DAC clock.

#### Subclass 0

Subclass 0 mode gives deterministic latency to within 4 DAC clock periods. It does not require any signal on the SYSREF $\pm$  pins (the pins can be left disconnected).

Subclass 0 still requires that all lanes arrive within the same LMFC cycle and the dual DACs must be synchronized to each other (they are synchronized to an internal clock instead of the SYSREF $\pm$  signal).

Set Subclass to 0 or 1 as desired.

### Link Delay Setup

Use LMFCVar and LMFCDel to impose delays such that all lanes in a system arrive in the same LMFC cycle.

The unit used internally for delays is the period of the internal processing clock (PClock), whose rate is 1/40<sup>th</sup> of the lane rate. Delays that are not in PClock cycles must be converted before they are used.

Some useful internal relationships are defined below:

$$PClock\ period = 40/LaneRate$$

The PClock period can be used to convert from time to PClock cycles when needed.

$$PClockFactor = 4/F \text{ (Frames per PClock)}$$

PClockFactor is used to convert from units of PClock cycles to frame clock cycles, which is needed to set LMFCDel in Subclass 1.

$$PClocksPerMF = K/PClockFactor \text{ (PClocks per LMFC cycle)}$$

where *PClocksPerMF* is the number of PClock cycles in a multiframe cycle.

The values for PClockFactor and PClockPerMF are given per JESD204B mode in Table 30.

**Table 30. PClockFactor and PClockPerMF Per JESD204B Mode**

JESD204B Mode ID	4	5	6	7	9	10
PClockFactor	4	2	2	1	4	2
PClockPerMF (K = 32)	8	16	16	32	8	16
PClockPerMF (K = 16)	N/A <sup>1</sup>	8	8	16	N/A <sup>1</sup>	8

<sup>1</sup> N/A means not applicable.

### With Known Delays

With information about all the system delays, LMFCVar and LMFCDel can be calculated directly.

RxFixed (the fixed receiver delay in PClock cycles) and RxVar (the variable receiver delay in PClock cycles) can be found in Table 8. TxFixed (the fixed transmitter delay in PClock cycles) and TxVar (the variable transmitter delay in PClock cycles) can be found in the data sheet of the transmitter used. PCBFixed (the fixed PCB trace delay in PClock cycles) can be extracted from the software; because this is generally much smaller than a PClock cycle, it can also be omitted. For both the PCB and transmitter delays, convert the delays into PClock cycles.

For each lane,

$$MinDelayLane = \text{floor}(RxFixed + TxFixed + PCBFixed)$$

$$MaxDelayLane = \text{ceiling}(RxFixed + RxVar + TxFixed + TxVar + PCBFixed)$$

Across lanes, links, and devices:

*MinDelay* is the minimum of all *MinDelayLane* values.

*MaxDelay* is the maximum of all *MaxDelayLane* values.

For safety, add a guard band of 1 PClock cycle to each end of the link delay as in the following equations:

$$LMFCVar = (MaxDelay + 1) - (MinDelay - 1)$$

Note that if LMFCVar must be more than 10, the AD9152 cannot tolerate the variable delay in the system.

For Subclass 1,

$$LMFCDel = ((MinDelay - 1) \times PClockFactor) \% K$$

For Subclass 0,

$$LMFCDel = (MinDelay - 1) \% PClockPerMF$$

Program the same LMFCDel and LMFCVar across all links and devices.

See the Link Delay Setup Example, with Known Delays section for an example calculation.

### Without Known Delays

If comprehensive delay information is not available or known, the AD9152 can read back the link latency between the LMFC<sub>RX</sub> and the last arriving LMFC boundary in PClock cycles. This information is then used to calculate LMFCVar and LMFCDel.

For each link (on each device),

1. Power up the board.
2. Follow the steps in Table 15 through Table 23 of the Device Setup Guide.
3. Set the subclass and perform a sync. For one shot sync, perform the writes in Table 31. See the Syncing LMFC Signals section for alternate sync modes.
4. Record DYN\_LINK\_LATENCY\_0 (Register 0x302) as a value of Delay for that link and power cycle.

Repeat Steps 1 to Step 4 twenty times for each device in the system. Keep a single list of the Delay values across all runs and devices.

**Table 31. Register Configuration and Procedure for One Shot Sync**

Addr.	Bit. No.	Value <sup>1</sup>	Variable	Description
0x301		0x	Subclass	Set the subclass
0x03A		0x01		Set sync mode to one shot sync
0x03A		0x81		Enable the sync machine
0x03A		0xC1		Arm the sync machine
SYSREF±				If Subclass = 1, ensure that at least one SYSREF± edge is sent to the device
0x300		0x		Enable the link
	6		ChkSmMd	See the JESD204B Setup section
	0		1	Enable the link

<sup>1</sup> 0x denotes a register value that the user must fill in. See the Variable and Description columns for information on selecting the appropriate register value.

The list of delay values is used to calculate LMFCDel and LMFCVar, but first some of the delay values may need to be remapped.

The maximum possible value for DYN\_LINK\_LATENCY is one less than the number of PClocks in a multiframe (PClocksPerMF). It is possible that a rollover condition may be encountered, meaning the set of recorded Delay values might roll over the edge of a multiframe. If so, Delay values may be near both 0 and PClocksPerMF. If this occurs, add PClocksPerMF to the set of values near 0.

For example, for Delay value readbacks of 6, 7, 0, and 1, the 0 and 1 Delay values must be remapped to 8 and 9, making the new set of Delay values 6, 7, 8, and 9.

Across power cycles, links, and devices.

- MinDelay is the minimum of all Delay measurements.
- MaxDelay is the maximum of all Delay measurements.

For safety, a guard band of 1 PClock cycle is added to each end of the link delay and calculate LMFCVar and LMFCDel with the following equation:

$$LMFCVar = (MaxDelay + 1) - (MinDelay - 1)$$

Note that if LMFCVar must be more than 10, the [AD9152](#) cannot tolerate the variable delay in the system.

For Subclass 1,

$$LMFCDel = ((MinDelay - 1) \times PClockFactor) \% K$$

For Subclass 0,

$$LMFCDel = (MinDelay - 1) \% PClockPerMF$$

Program the same LMFCDel and LMFCVar across all links and devices.

See the Link Delay Setup Example, Without Known Delays section for an example calculation.

### CROSSBAR SETUP

Register 0x308 and Register 0x309 allow arbitrary mapping of physical lanes (SERDINx±) to logical lanes used by the SERDES deframers.

**Table 32. Crossbar Registers**

Address	Bits	Logical Lane
0x308	[2:0]	LOGICAL_LANE0_SRC
0x308	[5:3]	LOGICAL_LANE1_SRC
0x309	[2:0]	LOGICAL_LANE2_SRC
0x309	[5:3]	LOGICAL_LANE3_SRC

Write each LOGICAL\_LANE<sub>x</sub>\_SRC with the number (x) of the desired physical lane (SERDINx±) from which to receive data. By default, all logical lanes use the corresponding physical lane as their data source. For example, by default LOGICAL\_LANE0\_SRC = 0, meaning Logical Lane 0 receives data from Physical Lane 0 (SERDIN0±). If instead the user wants to use SERDIN3± as the source for Logical Lane 0, the user must write LOGICAL\_LANE0\_SRC = 3.

# JESD204B SERIAL DATA INTERFACE

## JESD204B OVERVIEW

The AD9152 has four JESD204B data ports that receive data. The four JESD204B ports can be configured as part of a single JESD204B link. The AD9152 supports single link only.

The JESD204B serial interface hardware consists of three layers: the physical layer, the data link layer, and the transport layer. These sections of the hardware are described in subsequent sections, including information for configuring every aspect of the interface. Figure 37 shows the communication layers implemented in the AD9152 serial data interface to recover the clock and deserialize, descramble, and deframe the data before it is sent to the digital signal processing section of the device.

The physical layer establishes a reliable channel between the transmitter and the receiver, the data link layer unpacks the data into octets and descrambles the data, and the transport layer receives the descrambled JESD204B frames and converts them to DAC samples.

A number of JESD204B parameters (L, F, K, M, N, Np, S, HD, and Scrambling) define how the data is packed and instruct the device how to turn the serial data into samples. These parameters are defined in detail in the Transport Layer section. Only certain combinations of parameters are supported. Each supported combination is called a mode. In total, six single link modes are supported by the AD9152, as described in Table 33, which shows the associated clock rates when the lane rate is 10 Gbps.

Achieving and recovering synchronization of the lanes is very important. To simplify the interface to the transmitter, the AD9152 designates a master synchronization signal for the JESD204B link. SYNCOUT± is used as the master signal for all lanes. If any lane in the link loses synchronization, a resynchronization request is sent to the transmitter via the synchronization signal. The transmitter stops sending data and instead sends synchronization characters to all lanes in the link until resynchronization is achieved.

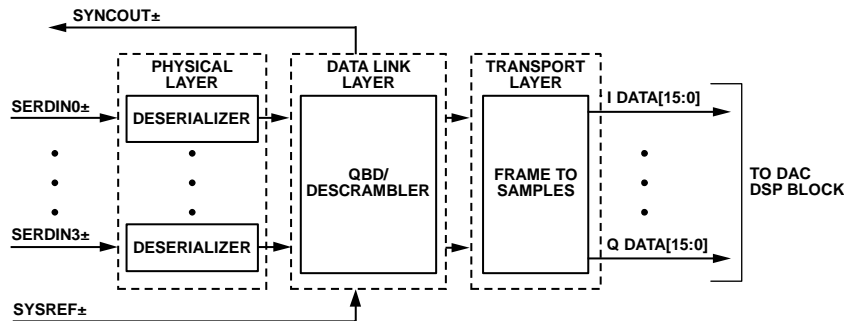

Figure 37. Functional Block Diagram of Serial Link Receiver

Table 33. Single Link JESD204B Operating Modes

Parameter	Mode					
	4	5	6	7	9	10
M (Converter Counts)	2	2	2	2	1	1
L (Lane Counts)	4	4	2	1	2	1
S (Samples per Converter per Frame)	1	2	1	1	1	1
F (Octets per Frame per Lane)	1	2	2	4	1	2
Example Clocks for 10 Gbps Lane Rate						
PClock (MHz)	250	250	250	250	250	250
Frame Clock (MHz)	1000	500	500	250	1000	500
Sample Clock (MHz)	1000	1000	500	250	1000	500

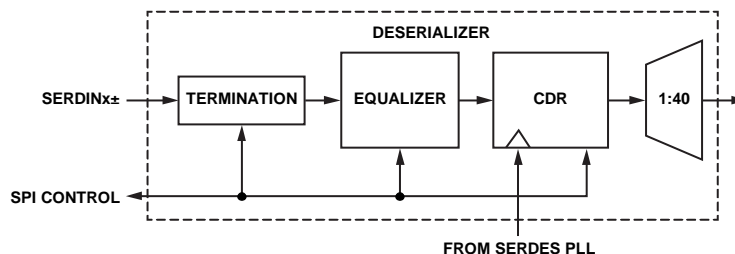

Figure 38. Deserializer Block Diagram

## PHYSICAL LAYER

The physical layer of the JESD204B interface, hereafter referred to as the deserializer, has four identical channels. Each channel consists of the terminators, an equalizer, a CDR circuit, and the 1:40 demux function (see Figure 38).

JESD204B data is input to the AD9152 via the SERDINx± differential input pins per the JESD204B specification.

### Interface Power-Up and Input Termination

Before using the JESD204B interface, it must be powered up by setting Register 0x200, Bit 0 = 0. In addition, each physical lane that is not being used (SERDINx±) must be powered down. To do so, set the corresponding Bit x for Physical Lane x in Register 0x201 to 0 if the physical lane is being used, and to 1 if it is not being used.

The AD9152 autocalibrates the input termination to 50 Ω. Before running the termination calibration, write to Register 0x2AA and Register 0x2AB as described in Table 34 to guarantee proper calibration. The termination calibration begins when Register 0x2A7, Bit 0 transitions from low to high.

The PHY termination autocalibration routine is as shown in Table 34.

**Table 34. PHY Termination Autocalibration Routine**

Address	Value	Description
0x2AA <sup>1</sup>	0xB7	JESD204B interface termination configuration
0x2AB <sup>1</sup>	0x87	JESD204B interface termination configuration
0x2A7	0x01	Autotune PHY terminations

<sup>1</sup> Register 0x2AA and Register 0x2A8 must be set to the recommend value in Table 34 and do not appear in the register map.

The input termination voltage of the DAC is sourced externally via the V<sub>TT</sub> pins (Pin 13 and Pin 30). Set V<sub>TT</sub> by connecting it to SVDD12. It is recommended to ac couple the JESD204B inputs to the JESD204B transmit device using 100 nF capacitors.

### Receiver Eye Mask

The AD9152 complies with the JESD204B specification regarding the receiver eye mask and is capable of capturing data that complies with this mask. Figure 39 shows the receiver eye mask normalized to the data rate interval with a V<sub>TT</sub> swing of 600 mV. See the JESD204B specification for more information regarding the eye mask and permitted receiver eye opening.

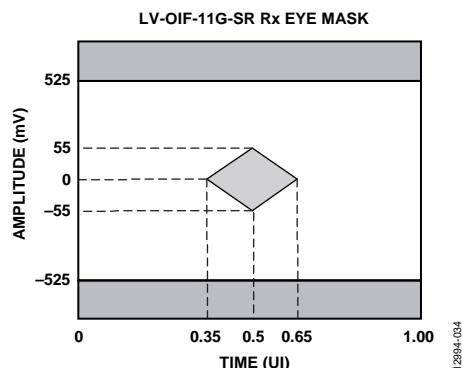

Figure 39. Receiver Eye Mask

## Clock Relationships

The following clocks rates are used throughout the rest of the JESD204B section. The relationship between any of the clocks can be derived from the following equations:

$$DataRate = (DACRate)/(InterpolationFactor)$$

$$LaneRate = (20 \times DataRate \times M)/L$$

where:

M is the JESD204B parameter for converters per link.

L is the JESD204B parameter for lanes per link.

$$ByteRate = LaneRate/10$$

This comes from 8-bit/10-bit encoding, where each byte is represented by 10 bits.

$$PClockRate = ByteRate/4$$

The processing clock is used for a quad-byte decoder.

$$FrameRate = ByteRate/F$$

where F is defined as octets per frame per lane.

$$PClockFactor = FrameRate/PClockRate = 4/F$$

## SERDES PLL

### Functional Overview of the SERDES PLL

The independent SERDES PLL uses integer-N techniques to achieve clock synthesis. The entire SERDES PLL is integrated on chip, including the VCO and the loop filter. The SERDES PLL VCO operates over the range of 5.75 GHz to 12.38 GHz.

In the SERDES PLL, a VCO divider block divides the VCO clock by 2 to generate a 2.88 GHz to 6.19 GHz quadrature clock for the deserializer cores. This clock is the input to the clock and data recovery block that is described in the Clock and Data Recovery section.

The reference clock to the SERDES PLL is always running at a frequency, f<sub>REF</sub>, that is equal to 1/40 of the lane rate (PClockRate). This clock is divided by the DivFactor value to deliver a clock to the PFD block that is between 35 MHz and 80 MHz. Table 35 includes the respective SERDES\_PLL\_DIV\_MODE settings for each of the desired DivFactor options available.

**Table 35. SERDES PLL Divider Settings**

LaneRate (Gbps)	Divide by (DivFactor)	SERDES_PLL_DIV_MODE Register 0x289, Bits[1:0]
1.44 to 3.09	1	2
2.88 to 6.19	2	1
5.75 to 12.38	4	0

Register 0x280 controls the synthesizer enable and recalibration.

To enable the SERDES PLL, first set the PLL divider register according to Table 35, and then enable the SERDES PLL by writing 1 to Register 0x280, Bit 0.

Confirm that the SERDES PLL is working by reading Register 0x281. If Register 0x281, Bit 0 = 1, the SERDES PLL has locked. If Register 0x281, Bit 3 = 1, the SERDES PLL was calibrated. If Register 0x281, Bit 4 or Register 0x281, Bit 5 are high, the PLL has reached the upper or lower end of its calibration band and must be recalibrated by writing 0 and then 1 to Register 0x280, Bit 2.

**SERDES PLL IRQ**

The SERDES PLL lock and lost signals are available as IRQ events. Use Register 0x01F, Bits[4:3] to enable these signals, and then use Register 0x023, Bits[4:3] to read back their statuses and reset the IRQ signals. See the Interrupt Request Operation section for more information.

**SERDES PLL Fixed Register Writes**

To optimize the PLL across all operating conditions, the SPI writes shown in Table 16 and Table 77 are required.

These writes properly set up the SERDES PLL, including the loop filter and the charge pump.

Table 36 is a lookup table for SPI register writes included in Table 16 and Table 17.

**Table 36. SERDES PLL VCO Control Lookup Table**

SERDES PLL VCO Frequency	0x296	0x291	0x28A
< 7.15 GHz	0x02	0x49	0x7B
≥ 7.15 GHz	0x03	0x4C	0x2B

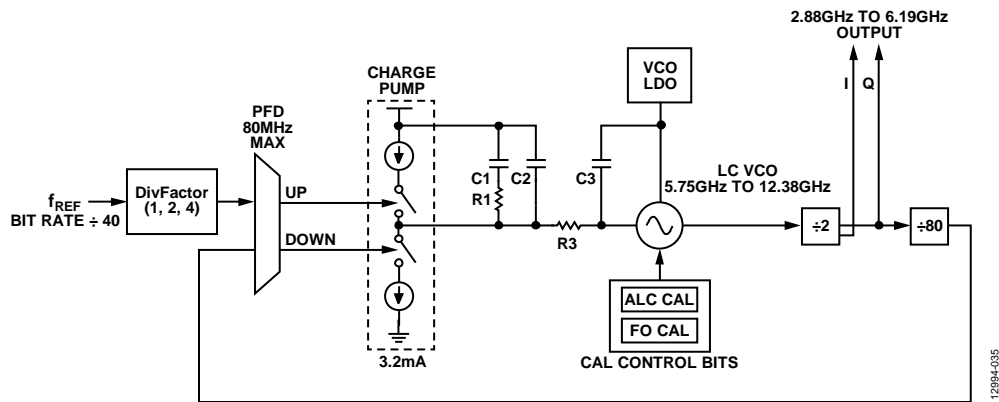

Figure 40. SERDES PLL Synthesizer Block Diagram Including VCO Divider Block

**Clock and Data Recovery**

The deserializer is equipped with a CDR circuit. Instead of recovering the clock from the JESD204B serial lanes, the CDR acquires the clocks from the SERDES PLL. The 2.88 GHz to 6.19 GHz output from the SERDES PLL, shown in Figure 40, is the input to the CDR.

A CDR sampling mode must be selected to generate the lane rate clock inside the device. If the desired lane rate is greater than 6.19 GHz, half rate CDR operation must be used. If the desired lane rate is less than 6.19 GHz, disable half rate operation. If the lane rate is less than 3.09 GHz, disable half rate and enable 2× oversampling to recover the appropriate lane rate clock. Table 37 gives a breakdown of the CDR sampling settings that must be set dependent on the LaneRate.

**Table 37. CDR Operating Modes**

LaneRate (Gbps)	ENHALFRATE, Register 0x230, Bit 5	CDR_OVERSAMP, Register 0x230, Bit 1
1.44 to 3.09	0	1
2.88 to 6.19	0	0
5.75 to 12.38	1	0

The CDR circuit synchronizes the phase used to sample the data on each serial lane independently. This independent phase adjustment per serial interface ensures accurate data sampling and eases the implementation of multiple serial interfaces on a PCB.

After configuring the CDR circuit, reset it and then release the reset by writing 1 and then 0 to Register 0x206, Bit 0.

**Power-Down Unused PHYs**

Note that any unused and enabled lanes consume extra power unnecessarily. Each lane that is not being used (SERDIN<sub>x±</sub>) must be powered off by writing a 1 to the corresponding bit of PHY\_PD (Register 0x201).

**Equalization**

To compensate for signal integrity distortions for each PHY channel due to PCB trace length and impedance, the AD9152 employs an easy to use, low power equalizer on each JESD204B channel. The AD9152 equalizers can compensate for insertion losses far greater than required by the JESD204B specification. The equalizers have two modes of operation determined by the EQ\_POWER\_MODE register setting in Register 0x268, Bits[7:6]. In low power mode (Register 0x268, Bits[7:6] = 2b'01) and operating at the maximum lane rate of 10 Gbps, the equalizer can compensate for up to 12 dB of insertion loss. In normal mode (Register 0x268, Bits[7:6] = 2b'00), the equalizer can compensate for up to 17.5 dB of insertion loss. This performance is shown in Figure 41 as an overlay to the JESD204B specification for insertion loss. Figure 41 shows the equalization performance at 10.0 Gbps, near the maximum baud rate for the AD9152.

Figure 42 and Figure 43 are provided as points of reference for hardware designers and show the insertion loss for various lengths of well laid out stripline and microstrip transmission lines on FR4 materials. See the Board Level Hardware Considerations section for specific layout recommendations for the JESD204B channel.

Low power mode is recommended if the insertion loss of the JESD204B PCB channels is less than that of the most lossy supported channel for lower power mode (shown in Figure 41). If the insertion loss is greater than that, but still less than that of the most lossy supported channel for normal mode (shown in Figure 41), use normal mode. At 10 Gbps operation, the equalizer in normal mode consumes about 4 mW more power per lane used than in low power equalizer mode. Note that either mode can be used in conjunction with transmitter preemphasis to ensure functionality and/or optimize for power.

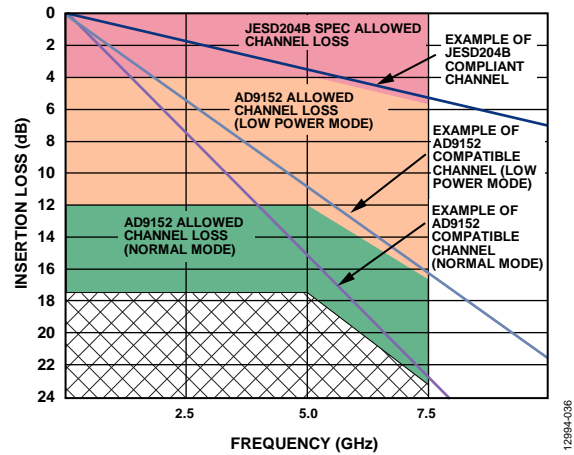

Figure 41. Insertion Loss Allowed

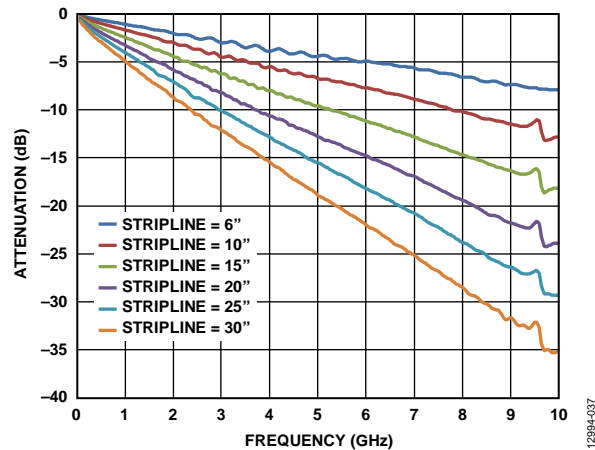

Figure 42. Insertion Loss of 50 Ω Striplines on FR-4

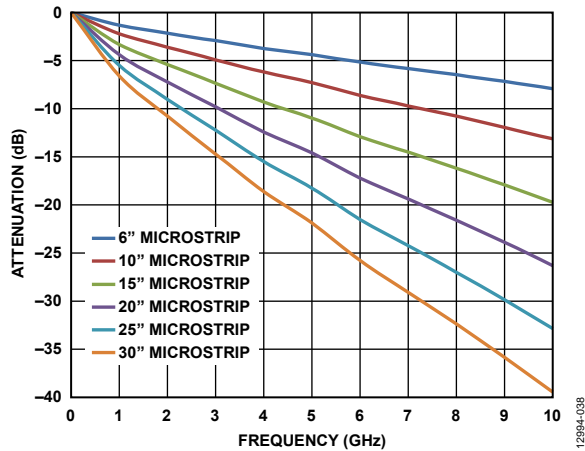

Figure 43. Insertion Loss of 50  $\Omega$  Microstrips on FR-4

**DATA LINK LAYER**

The data link layer of the AD9152 JESD204B interface accepts the deserialized data from the PHYs and deframes and descrambles them so that data octets are presented to the transport layer to be put into DAC samples. The architecture of the data link layer is shown in Figure 44. It consists of a synchronization FIFO for each lane, a crossbar switch, a deframer, and descrambler.

The AD9152 can operate as a single link high speed JESD204B serial data interface. All four lanes of the JESD204B interface handle link layer communications such as code group synchronization, frame alignment, and frame synchronization.

The AD9152 decodes 8-bit/10-bit control characters, allowing marking of the start and end of the frame and alignment between serial lanes. The AD9152 serial interface link can issue a synchronization request by setting the SYNCOUT± signal low. The synchronization protocol follows Section 4.9 of the JESD204B standard. When a stream of four consecutive /K/ symbols is received, the AD9152 deactivates the synchronization request by setting the SYNCOUT± signal high at the next internal LMFC rising edge. Then, the AD9152 waits for the transmitter to issue an initial lane alignment sequence (ILAS). During the ILAS sequence, all lanes are aligned using the /A/ to /R/ character transition as described in the JESD204B Serial Link Establishment section. Elastic buffers hold early arriving lane data until the alignment character of the latest lane arrives. At this point, the buffers for all lanes are released and all lanes are aligned (see Figure 45).

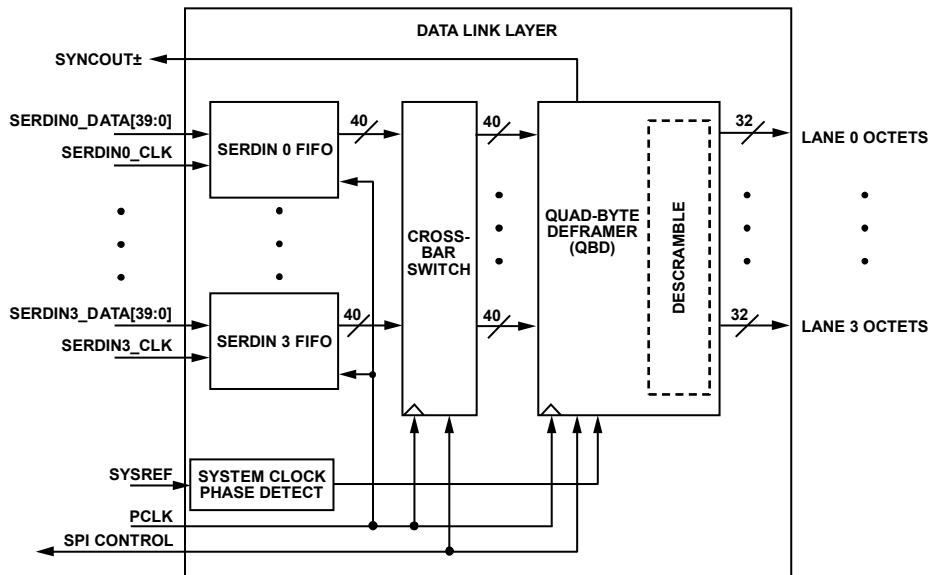

Figure 44. Data Link Layer Block Diagram

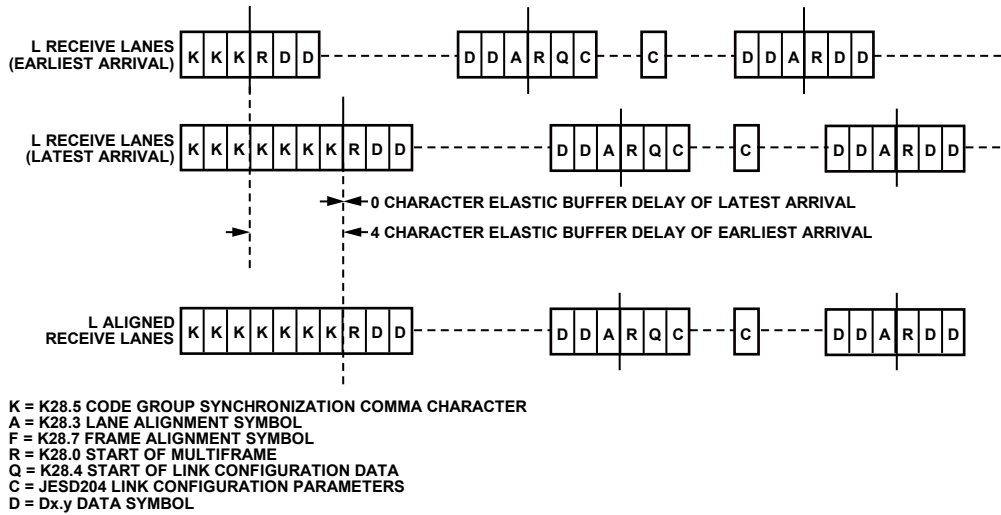

Figure 45. Lane Alignment During ILAS

12894-040

**JESD204B Serial Link Establishment**

A brief summary of the high speed serial link establishment process for Subclass 1 is provided. See Section 5.3.3 of the JESD204B specifications document for complete details.

**Step 1: Code Group Synchronization**

Each receiver must locate K (K28.5) characters in its input data stream. After four consecutive K characters are detected on all lanes, the receiver block deasserts the SYNCOUT± signal to the transmitter block at the receiver local multiframe clock (LMFC) edge.

The transmitter captures the change in the SYNCOUT± signal, and at a future transmitter LMFC rising edge, starts the ILAS.

**Step 2: Initial Lane Alignment Sequence**

The main purposes of this phase are to align all the lanes of the link and verify the parameters of the link.

Before the link is established, write each of the link parameters to the receiver device to designate how data is sent to the receiver block.

The ILAS consists of four or more multiframe. The last character of each multiframe is a multiframe alignment character, /A/. The first, third, and fourth multiframe are populated with predetermined data values. Note that Section 8.2 of the JESD204B specifications document describes the data ramp that is expected during ILAS. By default, the AD9152 does not require this ramp. Register 0x47E, Bit 0 can be set high to require the data ramp. The deframer uses the final /A/ of each lane to align the ends of the multiframe within the receiver. The second multiframe contains an R (K.28.0), Q (K.28.4), and then data corresponding to the link parameters. Additional multiframe can be added to the ILAS if needed by the receiver. By default, the AD9152 uses four multiframe in the ILAS (this can be changed in Register 0x478). If using Subclass 1, exactly four multiframe must be used.

After the last /A/ character of the last ILAS, multiframe data begins streaming.

**Step 3: Data Streaming**

In this phase, data is streamed from the transmitter block to the receiver block.

Optionally, data can be scrambled. Scrambling does not start until the very first octet following the ILAS.

The receiver block processes and monitors the data it receives for errors, including

- Bad running disparity (8-bit/10-bit error)
- Not in table (8-bit/10-bit error)
- Unexpected control character
- Bad ILAS
- Interlane skew error (through character replacement)

If any of these errors exist, they are reported back to the transmitter in one of a few ways (see the JESD204B Error Monitoring section for details).

- SYNCOUT± signal assertion: resynchronization (SYNCOUT± signal pulled low) is requested at each error for the last two errors. For the first three errors, an optional resynchronization request can be asserted when the error counter reaches a set error threshold.
- For the first three errors, each multiframe with an error in it causes a small pulse on SYNCOUT±.
- Errors can optionally trigger an IRQ event, which can be sent to the transmitter.

Various test modes for verifying the link integrity can be found in the JESD204B Test Modes section.

### Lane FIFO

The FIFOs in front of the crossbar switch and deframer synchronize the samples sent on the high speed serial data interface with the deframer clock by adjusting the phase of the incoming data. The FIFO absorbs timing variations between the data source and the deframer; this allows up to two PClock cycles of drift from the transmitter. The FIFO\_STATUS\_REG\_0 register and FIFO\_STATUS\_REG\_1 register (Register 0x30C and Register 0x30D, respectively) can be monitored to identify whether the FIFOs are full or empty.

### Lane FIFO IRQ

An aggregate lane FIFO error bit is also available as an IRQ event. Use Register 0x01F, Bit 1 to enable the FIFO error bit, and then use Register 0x023, Bit 1 to read back its status and reset the IRQ signal. See the Interrupt Request Operation section for more information.

### Crossbar Switch

Register 0x308 and Register 0x309 allow arbitrary mapping of physical lanes (SERDINx±) to logical lanes used by the SERDES deframers.

**Table 38. Crossbar Registers**

Address	Bits	Logical Lane
0x308	[2:0]	LOGICAL_LANE0_SRC
0x308	[5:3]	LOGICAL_LANE1_SRC
0x309	[2:0]	LOGICAL_LANE2_SRC
0x309	[5:3]	LOGICAL_LANE3_SRC

Write each LOGICAL\_LANEy\_SRC with the number (x) of the desired physical lane (SERDINx±) from which to receive data. By default, all logical lanes use the corresponding physical lane as their data source. For example, by default LOGICAL\_LANE0\_SRC = 0, thus Logical Lane 0 receives data from Physical Lane 0 (SERDIN0±). If instead the user wants to use SERDIN3± as the source for Logical Lane 0, the user must write LOGICAL\_LANE0\_SRC = 3.

### Lane Inversion

Register 0x334 allows inversion of desired logical lanes, which can be used to ease routing of the SERDINx± signals. For each Logical Lane x, set Bit x of Register 0x334 to 1 to invert it.

### Deframer

The AD9152 consists of one quad byte deframer (QBD). The deframer takes in the 8-bit/10-bit encoded data from the deserializer (via the crossbar switch), decodes it, and descrambles it into JESD204B frames before passing it to the transport layer to be converted to DAC samples. The deframer processes four symbols (or octets) per processing clock (PClock) cycle.

The deframer uses the JESD204B parameters that the user has programmed into the register map to identify how the data has been packed and unpack it. The JESD204B parameters are discussed in detail in the Transport Layer section; many of the parameters are also needed in the transport layer to convert JESD204B frames into samples.

### Descrambler

The AD9152 provides an optional descrambler block using a self synchronous descrambler with a polynomial:  $1 + x^{14} + x^{15}$ .

Enabling data scrambling reduces spectral peaks that are produced when the same data octets repeat from frame to frame. It also makes the spectrum data independent so that possible frequency selective effects on the electrical interface do not cause data dependent errors. Descrambling of the data is enabled by setting the SCR bit (Register 0x453, Bit 7) to 1.

### Syncing LMFC Signals

The first step in guaranteeing synchronization across devices begins with syncing the LMFC signals. The I DAC and Q DAC share one LMFC signal. In Subclass 0, the LMFC signal is synchronized to an internal processing clock. In Subclass 1, all LMFC signals for all devices are synchronized to an external SYSREF± signal.

The SYSREF± signal is a differential source synchronous input that synchronizes the LMFC signals in both the transmitter and receiver in a JESD204B Subclass 1 system to achieve deterministic latency.

The SYSREF± signal is an active high signal that is sampled by the device clock rising edge. It is best practice that the device clock and SYSREF± signals be generated by the same source, such as a AD9516-1 clock generator, so that the phase alignment between the signals is fixed. When designing for optimum deterministic latency operation, consider the timing distribution skew of the SYSREF± signal in a multipoint link system (multichip).

The AD9152 supports a single pulse or step, or a periodic SYSREF± signal. The periodicity can be continuous, strobed, or gapped periodic. The SYSREF± signal can be dc-coupled (with a common-mode voltage of 0 V to 2 V) or ac-coupled. When dc-coupled, a small amount of common-mode current (<500 μA) is drawn from the SYSREF± pins. See Figure 46 for the SYSREF± internal circuit.

To avoid this common-mode current draw, use a 50% duty-cycle periodic SYSREF± signal with ac coupling capacitors. If ac-coupled, the ac coupling capacitors combine with the resistors shown in Figure 46 to make a high-pass filter with an RC time constant of  $\tau = RC$ . Select C such that  $\tau > 4 / \text{SYSREF}\pm$  frequency.

In addition, the edge rate must be sufficiently fast—at least 6.3 V/ns is recommended per Table 5—to meet the SYSREF± vs. DAC clock keep out window (KOW) requirements.

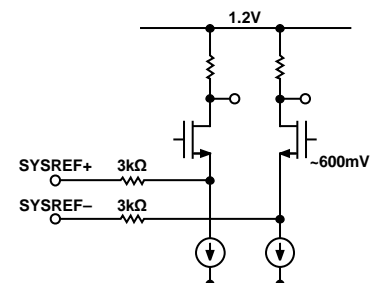

Figure 46. SYSREF± Input Circuit

## Sync Processing Modes Overview

The AD9152 supports various LMFC sync processing modes. These modes are one shot, continuous, windowed continuous, and monitor modes. All sync processing modes perform a phase check to see that the LMFC is phase aligned to an alignment edge. In Subclass 1, the SYSREF± pulse acts as the alignment edge; in Subclass 0, an internal processing clock acts as the alignment edge. If the signals are not in phase, a clock rotation occurs to align the signals. The sync modes are described in the following sections. See the Sync Procedure section for details on the procedure for syncing the LMFC signals.

### One Shot Sync Mode (SYNCMODE = 0x1)

In one shot sync mode, a phase check occurs on only the first alignment edge that is received after the sync machine is armed. If the phase error is larger than a specified window error tolerance, a phase adjustment occurs. Though an LMFC synchronization occurs only once, the SYSREF± signal can still be continuous.

### Continuous Sync Mode (SYNCMODE = 0x2)

Continuous mode must only be used in Subclass 1 with a periodic SYSREF± signal. In continuous mode, a phase check/alignment occurs on every alignment edge.

Continuous mode differs from the one shot mode in two ways. First, no SPI cycle is required to arm the device; the alignment edge seen after continuous mode is enabled results in a phase check. Second, a phase check (and when necessary, clock rotation) occurs on every alignment edge in continuous mode. The one caveat to the previous statement is that when a phase rotation cycle is underway, subsequent alignment edges are ignored until the logic lane is ready again.

The maximum acceptable phase error (in DAC clock cycles) between the alignment edge and the LMFC edge is set in the error window tolerance register. If continuous sync mode is used with a nonzero error window tolerance, a phase check occurs on every SYSREF± pulse, but an alignment occurs only if the phase error is greater than the specified error window tolerance. If the jitter of the SYSREF signal violates the KOW specification given in Table 5 and therefore causes phase error uncertainty, the error tolerance can be increased to avoid constant clock rotations. Note that this means that the latency is less deterministic by the size of the window. If the error window tolerance must be set above 3, Subclass 0 with one shot sync is recommended.

For debug purposes, SYNCARM (Register 0x03A, Bit 6) can be used to inform the user that alignment edges are being received in continuous mode. Because the SYNCARM bit is self cleared after an alignment edge is received, the user can arm the sync (SYNCARM (Register 0x03A, Bit 6) = 1), and then read back SYNCARM. If SYNCARM = 0, the alignment edges are being received and phase checks are occurring. Arming the sync machine in this mode does not affect the operation of the device.

### One Shot Then Monitor Sync Mode (SYNCMODE = 0x9)

In one shot then monitor mode, the user can monitor the phase error in real time. Use this sync mode with a periodic SYSREF± signal. A phase check and alignment occurs on the first alignment edge received after the sync machine is armed. On all subsequent alignment edges, the phase is monitored and reported, but no clock phase adjustment occurs.

The phase error can be monitored on the SYNC\_CURRERR register (Register 0x03C and Register 0x03D). Immediately after an alignment occurs, SYNC\_CURRERR is forced to 0 to indicate that there is no difference between the alignment edge and the LMFC edge. On every subsequent alignment edge, the phase is checked. If the alignment is lost, the phase error is reported in the SYNC\_CURRERR\_L register in DAC clock cycles. If the phase error is beyond the selected window tolerance (Register 0x034, Bits[2:0]), Bit 6 or Bit 7 of Register 0x03D is set high depending on whether the phase error is on low or high side.

When an alignment occurs, snapshots of the last phase error (Register 0x03C) and the corresponding error flags (Register 0x03D, Bits[7:6]) are placed into readable registers for reference (Register 0x038 and Register 0x039, respectively).

## Sync Procedure

The procedure for enabling the sync is as follows:

- Set the desired sync processing mode. The sync processing mode settings are listed in Table 39.
- For Subclass 1, set the error window according to the uncertainty of the SYSREF± signal relative to the DAC clock and the tolerance of the application for deterministic latency uncertainty. The sync window tolerance settings are given in Table 40.
- Enable sync by writing 1 to SYNCENABLE (Register 0x03A, Bit 7).
- If in one shot mode, arm the sync machine by writing 1 to SYNCARM (Register 0x03A, Bit 6).
- If in Subclass 1, ensure that at least one SYSREF± pulse is sent to the device.
- Check the status by reading the following bit fields:
  - SYNCBUSY (Register 0x03B, Bit 7) = 0 to indicate that the sync logic is no longer busy.
  - SYNCLOCK (Register 0x03B, Bit 3) = 1 to indicate that the signals are aligned. This bit updates on every phase check.
  - SYNCWLIM (Register 0x03B, Bit 1) = 0 to indicate that the phase error is not beyond the specified error window. This bit updates on every phase check.
  - SYNCROTATE (Register 0x03B, Bit 2) = 1 if the phases were not aligned before the sync and a clock alignment occurred. This bit is sticky and can be cleared only by writing to SYNCCLRSTKY control bit (Register 0x03A, Bit 5).
  - SYNCTRIP (Register 0x03B, Bit 0) = 1 to indicate that the alignment edge was received and the phase check occurred. This bit is sticky and can be cleared only by writing to SYNCCLRSTKY control bit (Register 0x03A, Bit 5).

**Table 39. Sync Processing Modes**

Sync Processing Mode	SYNCMODE (Register 0x03A, Bits[3:0])
One Shot	0x01
Continuous	0x02
One Shot Then Monitor	0x09

**Table 40. Sync Window Tolerance**

Sync Error Window Tolerance (DAC Clock Cycles)	ERRWINDOW (Register 0x034, Bits[2:0])
±½	0x00
±1	0x01
±2	0x02
±3	0x03
±4	0x04
±5	0x05
±6	0x06
±7	0x07

## LMFC Sync IRQ

The sync status bits (SYNCLOCK, SYNCROTATE, SYNCTRIP, and SYNCWLIM) are available as IRQ events.

Use Register 0x021, Bits[3:0] to enable the sync status bits, and then use Register 0x025, Bits[3:0] to read back their statuses and to reset the IRQ signals.

See the Interrupt Request Operation section for more information.

## Deterministic Latency

JESD204B systems contain various clock domains distributed throughout each system. Data traversing from one clock domain to a different clock domain can lead to ambiguous delays in the JESD204B link. These ambiguities lead to nonrepeatable latencies across the link from power cycle to power cycle with each new link establishment. Section 6 of the JESD204B specification addresses the issue of deterministic latency with mechanisms defined as Subclass 1 and Subclass 2.

The AD9152 supports JESD204B Subclass 0 and Subclass 1 operation, but not Subclass 2. Write the subclass to Register 0x301, Bits[2:0] and once per link to Register 0x458, Bits[7:5].

## Subclass 0

Subclass 0 mode does not require any signal on the SYSREF± pins, which can be left disconnected.

Subclass 0 still requires that all lanes arrive within the same LMFC cycle.

## Minor Subclass 0 Caveats

Because the AD9152 requires an ILAS, the nonmultiple converter single lane (NMCDA-SL) case from the JESD204A specification is supported only when using the optional ILAS.

Error reporting using SYNCOUT± is not supported when using Subclass 0 with F = 1.

## Subclass 1

Subclass 1 mode gives deterministic latency and allows links to be synced to within ½ a DAC clock period. It requires an external SYSREF± signal that is accurately phase aligned to the DAC clock.

## Deterministic Latency Requirements

Several key factors are required for achieving deterministic latency in a JESD204B Subclass 1 system.

- SYSREF± signal distribution skew within the system must be less than the desired uncertainty.
- SYSREF± setup and hold time requirements must be met for each device in the system.
- The total latency variation across all lanes, and devices must be ≤10 PClock periods. This includes both variable delays and the variation in fixed delays from lane to lane and device to device in the system.

**Link Delay**

The link delay of a JESD204B system is the sum of the fixed and variable delays from the transmitter, channel, and receiver as shown in Figure 49.

For proper functioning, all lanes on the link must be read during the same LMFC period. Section 6.1 of the JESD204B specification states that the LMFC period must be larger than the maximum link delay. For the AD9152, this is not necessarily the case; instead, the AD9152 uses a local LMFC for the link (LMFC<sub>Rx</sub>) that can be delayed from the SYSREF± aligned LMFC. Because the LMFC is periodic, this can account for any amount of fixed delay. As a result, the LMFC period must only be larger than the variation in

the link delays, and the AD9152 can achieve proper performance with a smaller total latency. Figure 47 and Figure 48 show a case where the link delay is larger than an LMFC period. Note that it can be accommodated by delaying LMFC<sub>Rx</sub>.

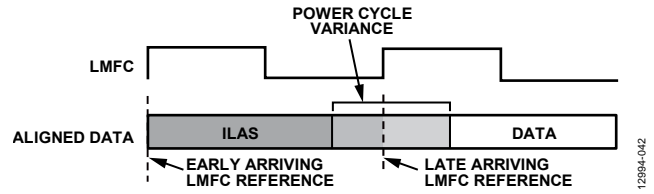

Figure 47. Link Delay > LMFC Period Example

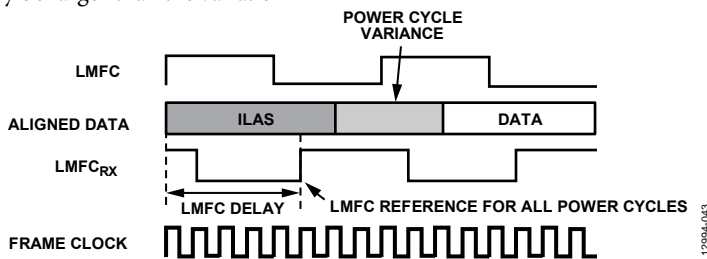

Figure 48. LMFC\_DELAY\_x to Compensate for Link Delay > LMFC

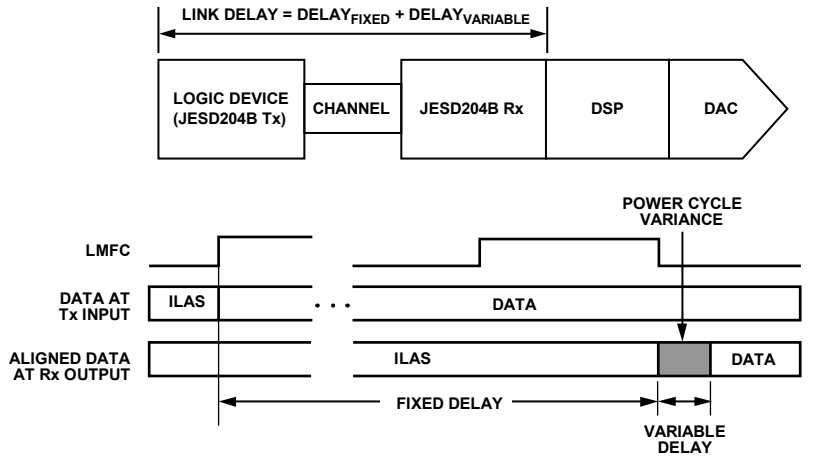

Figure 49. JESD204B Link Delay = Fixed Delay + Variable Delay

The method to select the LMFCDel (Register 0x304) and LMFCVar (Register 0x306) variables is described in the Link Delay Setup section.

Setting LMFCDel appropriately ensures that all the corresponding data samples arrive in the same LMFC period. Then LMFCVar is written into the receive buffer delay (RBD) to absorb all link delay variation. This ensures that all data samples have arrived before reading. By setting these to fixed values across runs and devices, deterministic latency is achieved.

The RBD described in the JESD204B specification takes values from one frame clock cycle to K frame clock cycles, while the RBD of the AD9152 takes values from 0 PClock cycles to 10 PClock cycles. As a result, up to 10 PClock cycles of total delay variation can be absorbed. Because LMFCVar is in PClock cycles, and LMFCDel is in frame clock cycles, a conversion between these two units is needed. The PClockFactor, or number of frame clock cycles per PClock cycle, is equal to 4/F. For more information on this relationship, see the Clock Relationships section.

Two examples follow that show how to determine LMFCVar and LMFCDel. After they are calculated, write LMFCDel into Register 0x304 for all devices in the system, and write LMFCVar to both Register 0x306 for all devices in the system.

**Link Delay Setup Example, with Known Delays**

All the known system delays can be used to calculate LMFCVar and LMFCDel as described in the Link Delay Setup section.

The example shown in Figure 50 is demonstrated in the following steps according to the procedure outlined in the Link Delay Setup section. Note that this example is in Subclass 1 to achieve deterministic latency, which has a PClockFactor (4/F) of two frame clock cycles per PClock cycle, and uses K = 32 (frames/multiframe). Because PCBFixed << PClockPeriod, PCBFixed is negligible in this example and not included in the calculations.

- Find the receiver delays using Table 8.  
 $RxFixed = 17$  PClock cycles  
 $RxVar = 2$  PClock cycles
- Find the transmitter delays. The equivalent table in the example JESD204B core (implemented on a GTH or GTX transceiver on a Virtex-6 FPGA) states that the delay is  $56 \pm 2$  byte clock cycles.  
 Because the  $PClockRate = ByteRate/4$  as described in the Clock Relationships section, the transmitter delays in PClock cycles are as follows:  
 $TxFixed = 54/4 = 13.5$  PClock cycles  
 $TxVar = 4/4 = 1$  PClock cycle
- Calculate MinDelayLane as follows:  
 $MinDelayLane = \text{floor}(RxFixed + TxFixed + PCBFixed)$   
 $= \text{floor}(17 + 13.5 + 0)$   
 $= \text{floor}(30.5)$   
 $MinDelayLane = 30$
- Calculate MaxDelayLane as follows:  
 $MaxDelayLane = \text{ceiling}(RxFixed + RxVar + TxFixed + TxVar + PCBFixed)$   
 $= \text{ceiling}(17 + 2 + 13.5 + 1 + 0)$   
 $= \text{ceiling}(33.5)$   
 $MaxDelayLane = 34$
- Calculate LMFCVar as follows:  
 $LMFCVar = (MaxDelay + 1) - (MinDelay - 1)$   
 $= (34 + 1) - (30 - 1) = 35 - 29$   
 $LMFCVar = 6$  PClock cycles
- Calculate LMFCDel as follows:  
 $LMFCDel = ((MinDelay - 1) \times PClockFactor) \% K$   
 $= ((30 - 1) \times 2) \% 32 = (29 \times 2) \% 32$   
 $= 58 \% 32$   
 $LMFCDel = 26$  frame clock cycles
- Write LMFCDel to Register 0x304 for all devices in the system. Write LMFCVar to Register 0x306 for all devices in the system.

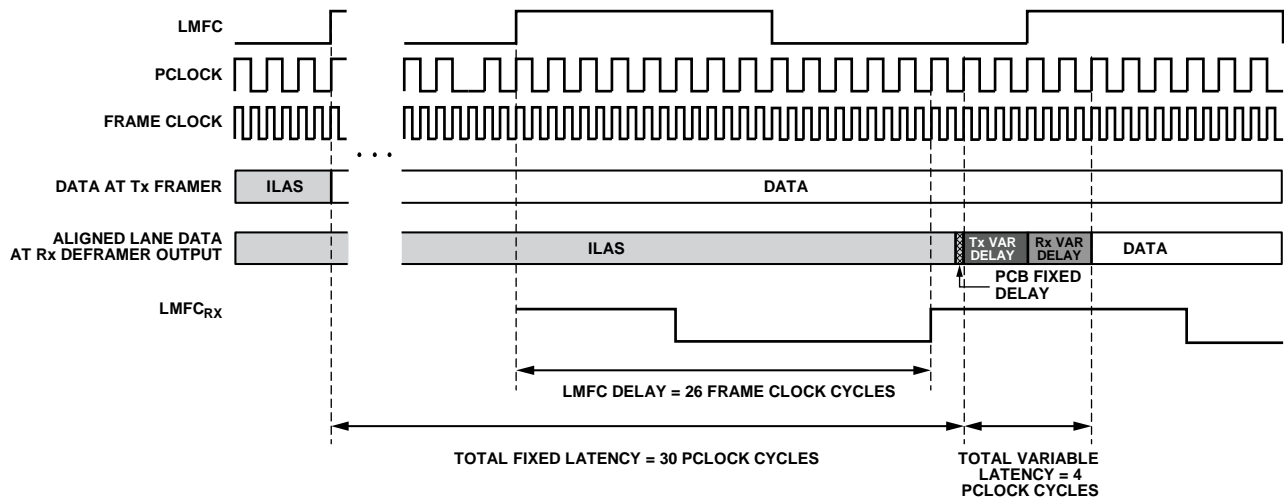

Figure 50. LMFC Delay Calculation Example

12994-045

**Link Delay Setup Example, Without Known Delays**

If the system delays are not known, the AD9152 can read back the link latency between LMFC<sub>RX</sub> for each link and the SYSREF± aligned LMFC. This information is then used to calculate LMFCVar and LMFCDel, as shown in the Without Known Delays section.

Figure 52 shows how DYN\_LINK\_LATENCY\_0 (Register 0x302) provides a readback showing the delay (in PClock cycles) between LMFC<sub>RX</sub> and the transition from ILAS to the first data sample. By repeatedly power-cycling and taking this measurement, the minimum and maximum delays across power cycles can be determined and used to calculate LMFCVar and LMFCDel.

The example shown in Figure 52 is demonstrated in the following steps according to the procedure outlined in the Without Known Delays section. Note that this example is in Subclass 1 to achieve deterministic latency, which has a PClockFactor (frame clock rate/PClockRate) of 2 and uses K = 16; therefore PClocksPerMF = 8.

1. In Figure 52, for Link A, Link B, and Link C, the system containing the AD9152 (including the transmitter) is power cycled and configured 20 times. The AD9152 is configured as described in the Device Setup Guide. Because the point of this exercise is to determine LMFCDel and LMFCVar, the LMFCDel is programmed to 0 and DYN\_LINK\_LATENCY\_0 is read from Register 0x302.

The variation in the link latency over the 20 runs is shown in Figure 52 in gray.

Link A gives readbacks of 6, 7, 0, and 1. Note that the set of recorded delay values rolls over the edge of a multiframe at the boundary K/PClockFactor = 8. Add PClocksPerMF = 8 to the low set. Delay values range from 6 to 9.

Link B gives Delay values from 5 to 7.

Link C gives Delay values from 4 to 7.

2. Calculate the minimum of all delay measurements across all power cycles, links, and devices:  
 $MinDelay = \min(\text{all Delay values}) = 4$
3. Calculate the maximum of all delay measurements across all power cycles, links, and devices:  
 $MaxDelay = \max(\text{all Delay values}) = 9$
4. Calculate the total delay variation (with guard band) across all power cycles, links, and devices:  
 $LMFCVar = (MaxDelay + 1) - (MinDelay - 1)$   
 $= (9 + 1) - (4 - 1) = 10 - 3 = 7$  PClock cycles
5. Calculate the minimum delay in frame clock cycles (with guard band) across all power cycles, links, and devices:  
 $LMFCDel = ((MinDelay - 1) \times PClockFactor) \% K$   
 $= ((4 - 1) \times 2) \% 16 = (3 \times 2) \% 16$   
 $= 6 \% 16 = 6$  frame clock cycles
6. Write LMFCDel to Register 0x304 for all devices in the system. Write LMFCVar to Register 0x306 for all devices in the system.

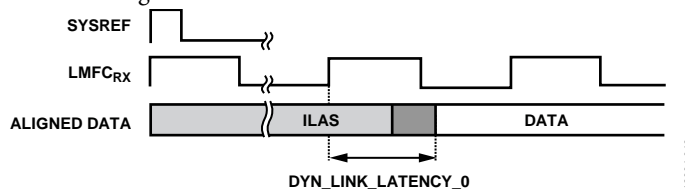

Figure 51. DYN\_LINK\_LATENCY\_0 Example

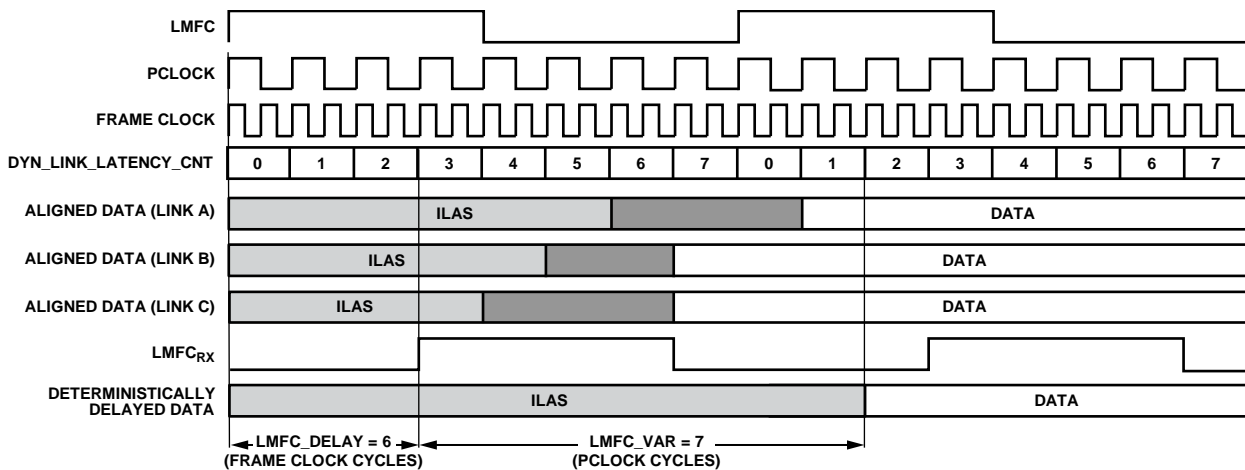

Figure 52. Multilink Synchronization Settings, Derived Method Example

**TRANSPORT LAYER**

The transport layer receives the descrambled JESD204B frames and converts them to DAC samples based on the programmed JESD204B parameters shown in Table 41. A number of device parameters are defined in Table 42.

**Table 41. JESD204B Transport Layer Parameters**

Parameter	Description
F	Number of octets per frame per lane: 1, 2, or 4.
K	Number of frames per multiframe. K = 32 if F = 1, K = 16 or 32 otherwise.
L	Number of lanes per converter device (per link), as follows: 1, 2, or 4 (single link mode).
M	Number of converters per device (per link), as follows: 1 or 2 (single link mode).
S	Number of samples per converter, per frame: 1 or 2.

**Table 42. JESD204B Device Parameters**

Parameter	Description
CF	Number of control words per device clock per link. Not supported, must be 0.
CS	Number of control bits per conversion sample. Not supported, must be 0.
HD	High density user data format. Used when samples must be split across lanes. Set to 1 when F = 1, otherwise 0.
N	Converter resolution = 16.
N' (or NP)	Total number of bits per sample = 16.

Certain combinations of these parameters, called JESD204B operating modes, are supported by the AD9152. See Table 43 for a list of supported modes, along with their associated clock relationships.

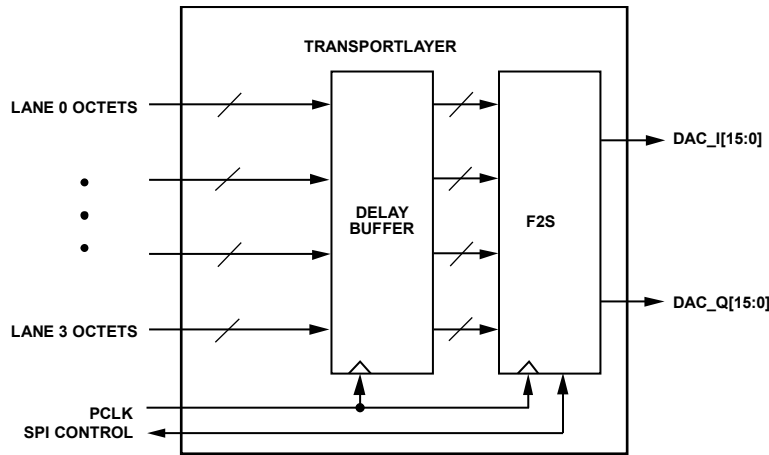

Figure 53. Transport Layer Block Diagram

**Table 43. Single Link JESD204B Operating Modes**

Parameter	Mode					
	4	5	6	7	9	10
M (Converter Count)	2	2	2	2	1	1
L (Lane Count)	4	4	2	1	2	1
S (Samples per Converter per Frame)	1	2	1	1	1	1
F (Octets per Frame, per Lane)	1	2	2	4	1	2
K <sup>1</sup> (Frames per Multiframe)	32	16/32	16/32	16/32	32	16/32
HD (High Density)	1	0	0	0	1	0
N (Converter Resolution)	16	16	16	16	16	16
NP (Bits per Sample)	16	16	16	16	16	16
Example Clocks for 10 Gbps Lane Rate						
PCLK Rate (MHz)	250	250	250	250	250	250
FrameClock Rate (MHz)	1000	500	500	250	1000	500
Data Rate (MHz)	1000	1000	500	250	1000	500

<sup>1</sup> K must be 32 in Mode 4 and Mode 9. It can be 16 or 32 in all other modes.

### Configuration Parameters

The AD9152 modes refer to the link configuration parameters for L, K, M, N, NP, S, and F. Table 44 provides the description and addresses for these settings.

**Table 44. Configuration Parameters**

JESD204B Setting	Description	Address
L – 1	Number of lanes – 1.	0x453[4:0]
F – 1	Number of ((octets per frame) per lane) – 1.	0x454[7:0]
K – 1	Number of frames per multiframe – 1.	0x455[4:0]
M – 1	Number of converters – 1.	0x456[7:0]
N – 1	Converter bit resolution – 1.	0x457[4:0]
NP – 1	Bit packing per sample – 1.	0x458[4:0]
S – 1	Number of ((samples per converter per frame) – 1.	0x459[4:0]
HD	High density format. Set to 1 if F = 1. Leave at 0 if F ≠ 1.	0x45A[7]
F <sup>1</sup>	F parameter, in ((octets per frame) per lane).	0x476[7:0]
DID	Device ID. Match the device ID sent by the transmitter.	0x450[7:0]
BID	Bank ID. Match the bank ID sent by the transmitter.	0x451[3:0]
LID0	Lane ID for Lane 0. Match the lane ID sent by the transmitter on Logical Lane 0.	0x452[4:0]
JESDV	JESD version. Match the version sent by the transmitter (0x0 = JESD204A, 0x1 = JESD204B).	0x459[7:5]

<sup>1</sup> The values that need to be written in Register 0x454 and Register 0x476 are different, F – 1 and F, respectively.

### Data Flow Through the JESD204B Receiver

The link configuration parameters determine how the serial bits on the JESD204B receiver interface are deframed and passed on to the DACs as data samples. Figure 54 shows a detailed flow of the data through the various hardware blocks for Mode 4 (L = 4, M = 2, S = 1, F = 1). Simplified flow diagrams for all other modes are shown in Figure 54 through Figure 59.

#### Single Link Configuration

The AD9152 uses the settings contained in Table 43. Mode 4 to Mode 10, except Mode 8, can be used for single link operation.

#### Checking Proper Configuration

As a convenience, the AD9152 provides quick configuration checks. Register 0x030, Bit 5 is high if an illegal LMFC\_DELAY\_0 value is used. Register 0x030, Bit 3 is high if an unsupported combination of L, M, F, or S is used. Register 0x030, Bit 2 is high if an illegal K character is used. Register 0x030, Bit 1 is high if an illegal SUBCLASSV is used.

#### Deskewing and Enabling Logical Lanes

After proper configuration, the logical lanes must be deskewed and enabled to capture data.

Set Bit x in Register 0x46C to 1 to deskew Logical Lane x and to 0 if that logical lane is not being used. Then, set Bit x in Register 0x47D to 1 to enable Logical Lane x and to 0 if that logical lane is not being used.

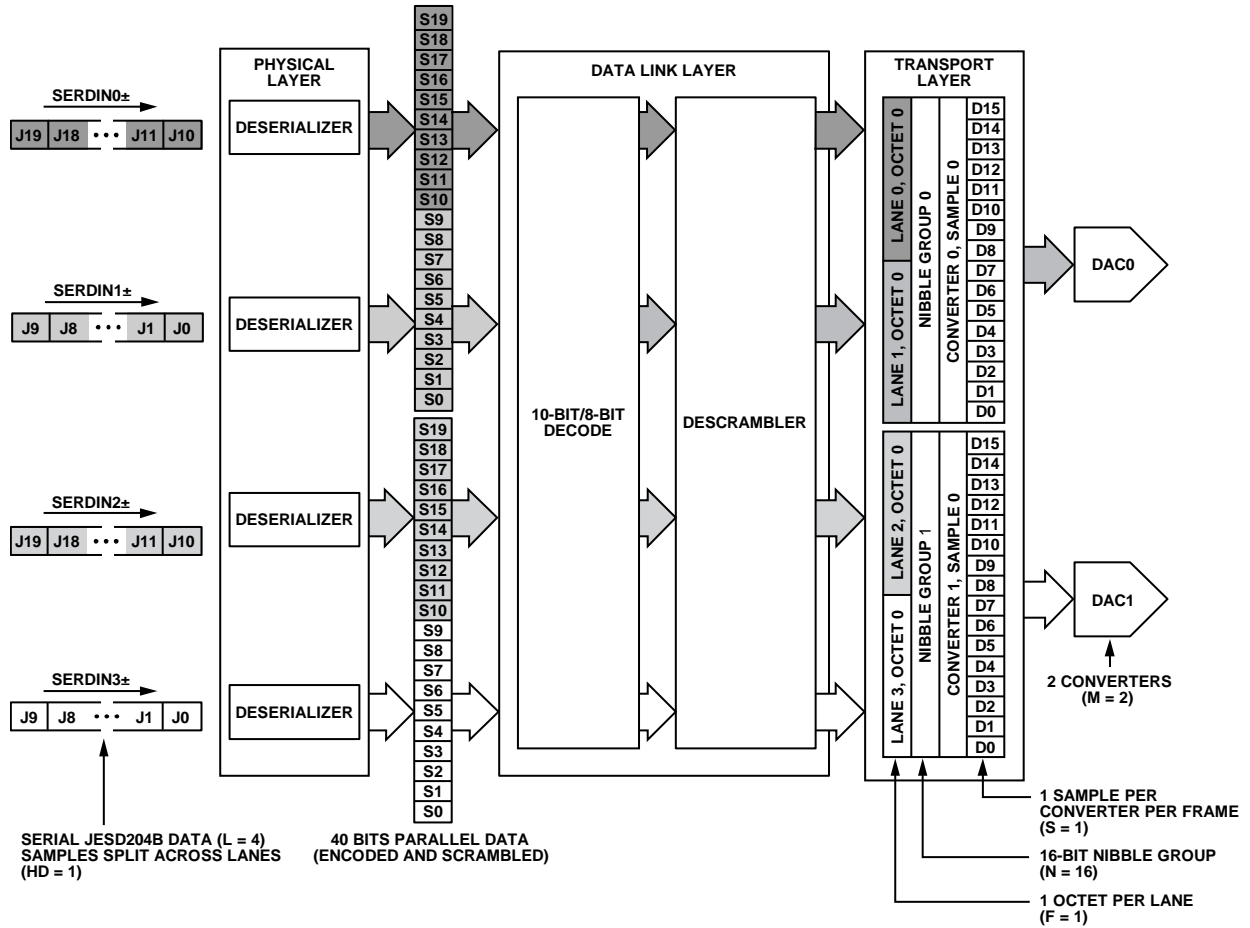

Figure 54. JESD204B Mode 4 Data Deframing

12994-049

**Mode Configuration Maps**

Table 45 to Table 50 contain the SPI configuration map for each mode shown in Figure 54 through Figure 59. Figure 54 through Figure 59 show the associated data flow through the deframing

process of the JESD204B receiver for each of the modes. Mode 4 to Mode 10, except Mode 8, apply to single link operation.

Additional details regarding all the SPI registers can be found in the Register Map and Descriptions section.

**Table 45. SPI Configuration Map—Register Settings for JESD204B Parameters for Mode 4**

Addr.	Setting	Description
0x453	0x03 or 0x83	Register 0x453, Bit 7 = 0 or 1: scrambling disabled or enabled; Register 0x453, Bits[4:0] = 0x3: L = 4 lanes per link
0x454	0x00	Register 0x454, Bits[7:0] = 0x00: F = 1 octet per frame per lane
0x455	0x1F	Register 0x455, Bits[4:0] = 0x1F: K = 32 frames per multiframe
0x456	0x01	Register 0x456, Bits[7:0] = 0x01: M = 2 converters per link
0x457	0x0F	Register 0x457, Bits[7:6] = 0x0: always set CS = 0; Register 0x457, Bits[4:0] = 0x0F: N = 16, always set to 16-bit resolution
0x458	0x0F or 0x2F	Register 0x458, Bits[7:5] = 0x0 or 0x1: Subclass 0 or Subclass 1, Register 0x458, Bits[4:0] = 0xF: NP = 16 bits per sample
0x459	0x20	Register 0x459, Bits[7:5] = 0x1: set to JESD204B version, Register 0x459, Bits[4:0] = 0x0: S = 1 sample per converter per frame
0x45A	0x80	Register 0x45A, Bit 7 = 1: HD = 1; Register 0x45A, Bits[4:0] = 0x00: always set CF = 0
0x46C	0x0F	Register 0x46C, Bits[7:0] = 0x0F: deskew Lane 0 to Lane 3
0x476	0x01	Register 0x476, Bits[7:0] = 0x01: F = 1 octet per frame
0x47D	0x0F	Register 0x47D, Bits[7:0] = 0x0F: enable Lane 0 to Lane 3

See Figure 54 for an illustration of the AD9152 JESD204B Mode 4 data deframing process.

**Table 46. SPI Configuration Map—Register Settings for JESD204B Parameters for Mode 5**

Addr.	Setting	Description
0x453	0x03 or 0x83	Register 0x453, Bit 7 = 0 or 1: scrambling disabled or enabled; Register 0x453, Bits[4:0] = 0x3: L = 4 lanes per converter
0x454	0x01	Register 0x454, Bits[7:0] = 0x01: F = 2 octets per frame per lane
0x455	0x0F or 0x1F	Register 0x455, Bits[4:0] = 0x0F or 0x1F: K = 16 or 32 frames per multiframe
0x456	0x01	Register 0x456, Bits[7:0] = 0x01: M = 2 converters per link
0x457	0x0F	Register 0x457, Bits[7:6] = 0x0: always set CS = 0; Register 0x457, Bits[4:0] = 0x0F: N = 16, always set to 16-bit resolution
0x458	0x0F or 0x2F	Register 0x458, Bits[7:5] = 0x0 or 0x1: Subclass 0 or Subclass 1, Register 0x458, Bits[4:0] = 0xF: NP = 16 bits per sample
0x459	0x21	Register 0x459, Bits[7:5] = 0x1: set to JESD204B version, Register 0x459, Bits[4:0] = 0x1: S = 2 samples per converter per frame
0x45A	0x00	Register 0x45A, Bit 7 = 0: HD = 0; Register 0x45A, Bits[4:0] = 0x00: always set CF = 0
0x46C	0x0F	Register 0x46C[7:0] = 0x0F: deskew Lane 0 to Lane 3
0x476	0x02	Register 0x476, Bits[7:0] = 0x02: F = 2 octets per frame
0x47D	0x0F	Register 0x47D, Bits[7:0] = 0x0F: 4 lanes enabled, set one bit per lane to enable

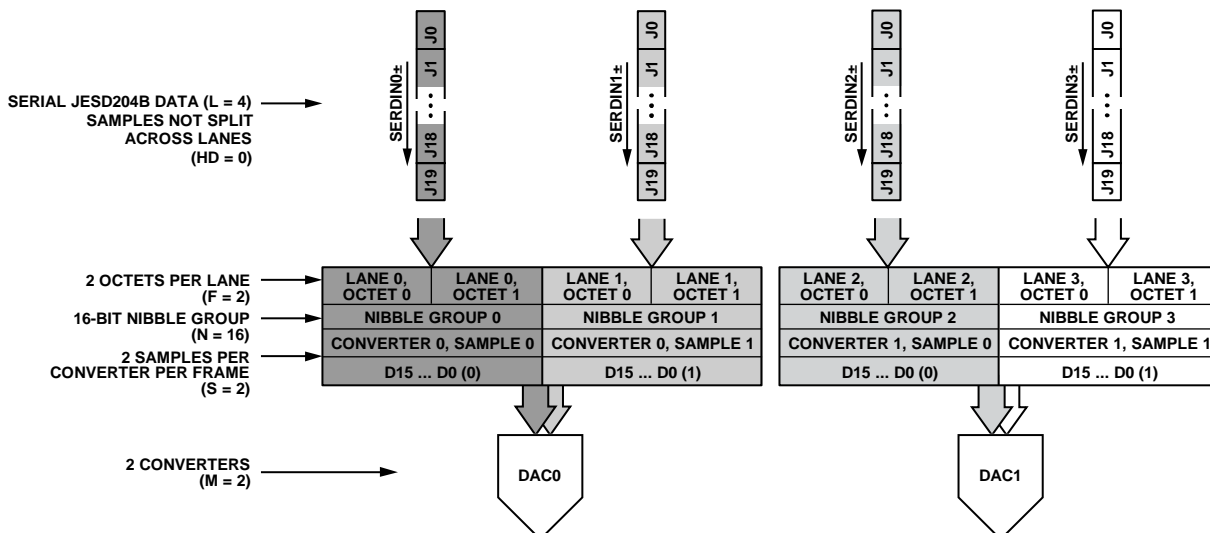

Figure 55. JESD204B Mode 5 Data Deframing

Table 47. SPI Configuration Map—Register Settings for JESD204B Parameters for Mode 6

Address	Setting	Description
0x453	0x01 or 0x81	Register 0x453, Bit 7 = 0 or 1: scrambling disabled or enabled, Register 0x453, Bits[4:0] = 0x1: L = 2 lanes per link
0x454	0x01	Register 0x454, Bits[7:0] = 0x01: F = 2 octets per frame per lane
0x455	0x0F or 0x1F	Register 0x455, Bits[4:0] = 0x0F or 0x1F: K = 16 or 32 frames per multiframe
0x456	0x01	Register 0x456, Bits[7:0] = 0x01: M = 2 converters per link
0x457	0x0F	Register 0x457, Bits[7:6] = 0x0: always set CS = 0; Register 0x457, Bits[4:0] = 0x0F: N = 16, always set to 16-bit resolution
0x458	0x0F or 0x2F	Register 0x458, Bits[7:5] = 0x0 or 0x1: Subclass 0 or Subclass 1, Register 0x458, Bits[4:0] = 0xF: NP = 16 bits per sample
0x459	0x20	Register 0x459, Bits[7:5] = 0x1: set to JESD204B version, Register 0x459, Bits[4:0] = 0x0: S = 1 sample per converter per frame
0x45A	0x00	Register 0x45A, Bit 7 = 0: HD = 0; Register 0x45A, Bits[4:0] = 0x00: always set CF = 0
0x46C	0x03	Register 0x46C, Bits[7:0] = 0x03: deskew Lane 0 and Lane 1
0x476	0x02	Register 0x476, Bits[7:0] = 0x02: F = 2 octets per frame
0x47D	0x03	Register 0x47D, Bits[7:0] = 0x03: enable Lane 0 and Lane 1

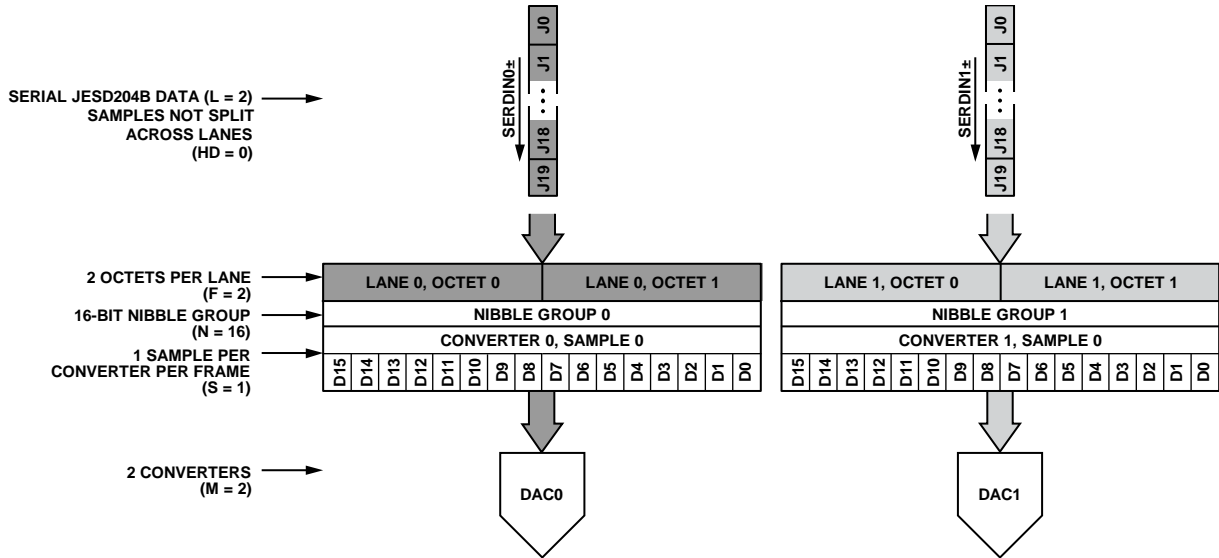

Figure 56. JESD204B Mode 6 Data Deframing

12894-051

Table 48. SPI Configuration Map—Register Settings for JESD204B Parameters for Mode 7

Address	Setting	Description
0x453	0x00 or 0x80	Register 0x453, Bit 7 = 0 or 1: scrambling disabled or enabled, Register 0x453, Bits[4:0] = 0x0: L = 1 lane per link
0x454	0x03	Register 0x454, Bits[7:0] = 0x03: F = 4 octets per frame per lane
0x455	0x0F or 0x1F	Register 0x455, Bits[4:0] = 0x0F or 0x1F: K = 16 or 32 frames per multiframe
0x456	0x01	Register 0x456, Bits[7:0] = 0x01: M = 2 converters per link
0x457	0x0F	Register 0x457, Bits[7:6] = 0x0: always set CS = 0; Register 0x457, Bits[4:0] = 0x0F: N = 16, always set to 16-bit resolution
0x458	0x0F or 0x2F	Register 0x458, Bits[7:5] = 0x0 or 0x1: Subclass 0 or Subclass 1, Register 0x458, Bits[4:0] = 0xF: NP = 16 bits per sample
0x459	0x20	Register 0x459, Bits[7:5] = 0x1: set to JESD204B version, Register 0x459, Bits[4:0] = 0x0: S = 1 sample per converter per frame
0x45A	0x00	Register 0x45A, Bit 7 = 0: HD = 0; Register 0x45A, Bits[4:0] = 0x00: always set CF = 0
0x46C	0x01	Register 0x46C, Bits[7:0] = 0x01: deskew Lane 0
0x476	0x04	Register 0x476, Bits[7:0] = 0x04: F = 4 octets per frame
0x47D	0x01	Register 0x47D, Bits[7:0] = 0x01: enable Lane 0

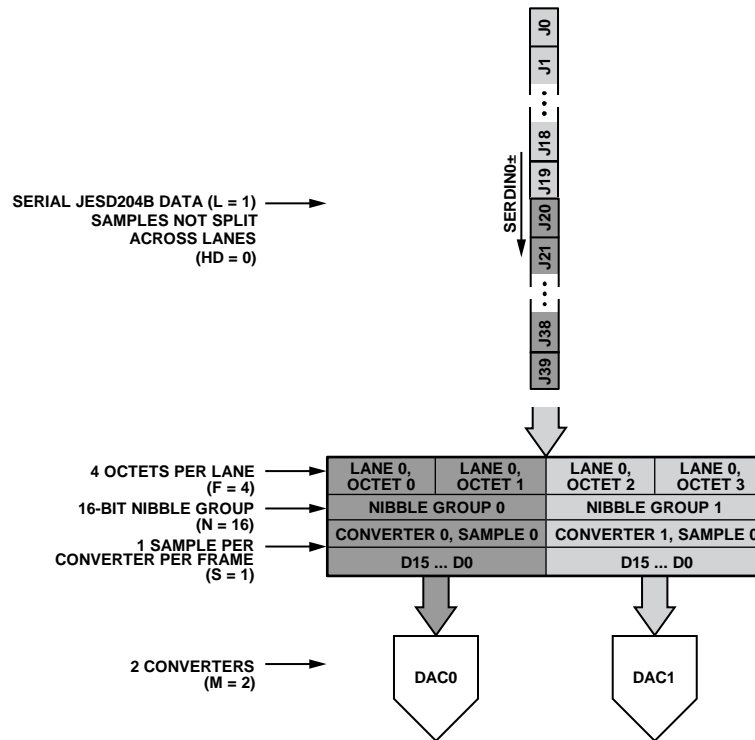

Figure 57. JESD204B Mode 7 Data Deframing

12964-062

Table 49. SPI Configuration Map—Register Settings for JESD204B Parameters for Mode 9

Address	Setting	Description
0x453	0x01 or 0x81	Register 0x453, Bit 7 = 0 or 1: scrambling disabled or enabled, Register 0x453, Bits[4:0] = 0x1: L = 2 lanes per link
0x454	0x00	Register 0x454, Bits[7:0] = 0x00: F = 1 octet per frame per lane
0x455	0x1F	Register 0x455, Bits[4:0] = 0x1F: K = 32 frames per multiframe
0x456	0x00	Register 0x456, Bits[7:0] = 0x00: M = 1 converter per link
0x457	0x0F	Register 0x457, Bits[7:6] = 0x0: always set CS = 0; Register 0x457, Bits[4:0] = 0x0F: N = 16, always set to 16-bit resolution
0x458	0x0F or 0x2F	Register 0x458, Bits[7:5] = 0x0 or 0x1: Subclass 0 or Subclass 1, Register 0x458, Bits[4:0] = 0xF: NP = 16 bits per sample
0x459	0x20	Register 0x459, Bits[7:5] = 0x1: Set to JESD204B version, Register 0x459, Bits[4:0] = 0x0: S = 1 sample per converter per frame
0x45A	0x80	Register 0x45A, Bit 7 = 1: HD = 1; Register 0x45A, Bits[4:0] = 0x00: always set CF = 0
0x46C	0x03	Register 0x46C, Bits[7:0] = 0x03: deskew Lane 0 and Lane 1
0x476	0x01	Register 0x476, Bits[7:0] = 0x01: F = 1 octet per frame
0x47D	0x03	Register 0x47D, Bits[7:0] = 0x03: enable Lane 0 and Lane 1

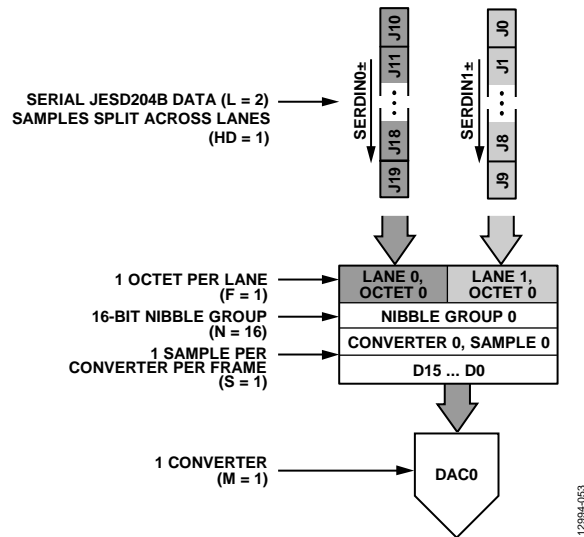

Figure 58. JESD204B Mode 9 Data Deframing

12894-053

Table 50. SPI Configuration Map—Register Settings for JESD204B Parameters for Mode 10

Address	Setting	Description
0x453	0x00 or 0x80	Register 0x453, Bit 7 = 0 or 1: scrambling disabled or enabled, Register 0x453, Bits[4:0] = 0x0: L = 1 lane per link
0x454	0x01	Register 0x454, Bits[7:0] = 0x01: F = 2 octets per frame per lane
0x455	0x0F or 0x1F	Register 0x455, Bits[4:0] = 0x0F or 0x1F: K = 16 or 32 frames per multiframe
0x456	0x00	Register 0x456, Bits[7:0] = 0x00: M = 1 converter per link
0x457	0x0F	Register 0x457, Bits[7:6] = 0x0: always set CS = 0; Register 0x457, Bits[4:0] = 0x0F: N = 16, always set to 16-bit resolution
0x458	0x0F or 0x2F	Register 0x458, Bits[7:5] = 0x0 or 0x1: Subclass 0 or Subclass 1, Register 0x458, Bits[4:0] = 0xF: NP = 16 bits per sample
0x459	0x20	Register 0x459, Bits[7:5] = 0x1: set to JESD204B version, Register 0x459, Bits[4:0] = 0x0: S = 1 sample per converter per frame
0x45A	0x00	Register 0x45A, Bit 7 = 0: HD = 0; Register 0x45A, Bits[4:0] = 0x00: always set CF = 0
0x46C	0x01	Register 0x46C, Bits[7:0] = 0x01: deskew Lane 0
0x476	0x02	Register 0x476, Bits[7:0] = 0x02: F = 2 octets per frame
0x47D	0x01	Register 0x47D, Bits[7:0] = 0x01: enable Lane 0

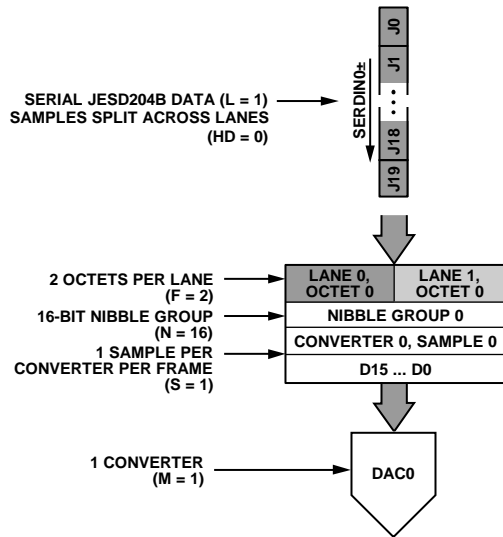

Figure 59. JESD204B Mode 10 Data Deframing

12994-054

## JESD204B TEST MODES

### PHY PRBS Testing

The JESD204B receiver on the [AD9152](#) includes a PRBS pattern checker on the back end of its physical layer. This functionality enables bit error rate (BER) testing of each physical lane of the JESD204B link. The PHY PRBS pattern checker does not require that the JESD204B link be established. It can synchronize with a PRBS7, PRBS15, or PRBS31 data pattern. PRBS pattern verification can be performed on multiple lanes at once. The error counts for failing lanes are reported for one JESD204B lane at a time. The process for performing PRBS testing on the [AD9152](#) is as follows:

1. Start sending a PRBS7, PRBS15, or PRBS31 pattern from the JESD204B transmitter.
2. Select and write the appropriate PRBS pattern to Register 0x316, Bits[3:2], as shown in Table 51.
3. Enable the PHY test for all lanes being tested by writing to PHY\_TEST\_EN (Register 0x315, Bits[3:0]). Each bit of Register 0x315 enables the PRBS test for the corresponding lane. For example, writing a 1 to Bit 0 enables the PRBS test for Physical Lane 0.
4. Toggle PHY\_TEST\_RESET (Register 0x316, Bit 0) from 0 to 1 then back to 0.
5. Set PHY\_PRBS\_ERROR\_THRESHOLD (Register 0x319 to Register 0x317) as desired.
6. Write a 0 and then a 1 to PHY\_TEST\_START (Register 0x316, Bit 1). The rising edge of PHY\_TEST\_START starts the test.
7. Wait 500 ms.
8. Stop the test by writing 0 to PHY\_TEST\_START (Register 0x316, Bit 1).
9. Read the PRBS test results.
  - a. Each bit of PHY\_PRBS\_PASS (Register 0x31D) corresponds to one SERDES lane. 0 = fail, 1 = pass.
  - b. The number of PRBS errors seen on each failing lane can be read by writing the lane number to check (0 to 3) in the PHY\_SRC\_ERR\_CNT (Register 0x316, Bits[6:4]) and reading the PHY\_PRBS\_ERR\_COUNT (Register 0x31C to Register 0x31A). The maximum error count is  $2^{24}-1$ . If all bits of Register 0x31C to Register 0x31A are high, the maximum error count on the selected lane has been exceeded.

**Table 51. PHY PRBS Pattern Selection**

PHY_PRBS_PAT_SEL Setting (Register 0x316, Bits[3:2])	PRBS Pattern
0b00 (default)	PRBS7
0b01	PRBS15
0b10	PRBS31

### Transport Layer Testing

The JESD204B receiver in the [AD9152](#) supports the short transport layer (STPL) test as described in the JESD204B standard. This test can be used to verify the data mapping between the JESD204B transmitter and receiver. To perform this test, this function must be implemented in the logic device and enabled there. Before running the test on the receiver side, the link must be established and running without errors (see the Device Setup Guide).

The STPL test ensures that each sample from each converter is mapped appropriately according to the number of converters (M) and the number of samples per converter (S). As specified in the JESD204B standard, the converter manufacturer specifies what test samples are transmitted. Each sample must have a unique value. For example, if M = 2 and S = 2, four unique samples are transmitted repeatedly until the test is stopped. The expected sample must be programmed into the device and the expected sample is compared to the received sample one sample at a time until all have been tested. The process to perform this test on the [AD9152](#) is described as follows:

1. Synchronize the JESD204B link.
2. Enable the STPL test at the JESD204B Tx.
3. Select Converter 0, Sample 0 for testing. Write 0 to SHORT\_TPL\_DAC\_SEL (Register 0x32C, Bits[3:2]) and 0 to SHORT\_TPL\_SP\_SEL (Register 0x32, Bits[5:4]).
4. Set the expected test sample for Converter 0, Sample 0. Program the expected 16-bit test sample into the SHORT\_TPL\_REF\_SP\_x registers (Register 0x32E and Register 0x32D).
5. Enable the STPL test. Write 1 to SHORT\_TPL\_TEST\_EN (Register 0x32C, Bit 0).
6. Toggle the STPL reset, SHORT\_TPL\_TEST\_RESET (Register 0x32C, Bit 1), from 0 to 1 then back to 0.
7. Check for failures. Read SHORT\_TPL\_FAIL (Register 0x32F, Bit 0), 0 = pass, 1 = fail.
8. Repeat Step 3 to Step 7 for each sample of each converter, Converter 0, Sample 0 through Converter M – 1, Sample S – 1.

### Repeated CGS and ILAS Test

Per Section 5.3.3.8.2 of the JESD204B specification, the [AD9152](#) can verify that a constant stream of K28.5 characters is being received, or that a CGS followed by a constant stream of ILAS is being received.

To run a repeated CGS test, send a constant stream of K28.5 characters to the [AD9152](#) SERDES inputs. Next, set up the device and enable the links as described in the Device Setup Guide section. Ensure that the K28.5 characters are being received by verifying that SYNCOUT± has been deasserted and that the CGS has passed for all enabled lanes by reading Register 0x470.

To run the CGS followed by a repeated ILAS sequence test, follow the Device Setup Guide section, but before performing the last write (enabling the links), enable the ILAS test mode by writing a 1 to Register 0x477, Bit 7. Then, enable the links. When the device recognizes four CGS characters on each lane, it deasserts the SYNCOUT± pins. At this point, the transmitter starts sending a repeated ILAS sequence.

Read Register 0x473 to verify that initial lane synchronization has passed for all enabled lanes.

## JESD204B ERROR MONITORING

### Disparity, Not in Table, and Unexpected Control Character Errors

Per Section 7.6 of the JESD204B specification, the AD9152 can detect disparity errors, not in table errors, and unexpected control character errors, and can optionally issue a sync request and reinitialize the link when errors occur.

Note that the disparity error counter counts all characters with invalid disparity, regardless of whether they are in the 8-bit/10-bit decoding table. This is a minor deviation from the JESD204B specification, which only counts disparity errors when they are in the 8-bit/10-bit decoding table.

### Checking Error Counts

The error count can be checked for disparity errors, not in table errors, and unexpected control character errors. The error counts are on a per lane and per error type basis. Note that the lane select and counter select are programmed into Register 0x46B and the error count is read back from the same address. To check the error count, complete the following steps:

1. Select the desired lane and error type of the counter to view. Write these to Register 0x46B according to Table 52.
2. Read the error count from Register 0x46B. Note that the maximum error count is equal to the error threshold set in Register 0x47C.

**Table 52. Error Counters**

Addr.	Bits	Variable	Description
0x46B	[6:4]	LaneSel	LaneSel = x to monitor the error count of Lane x.
	[1:0]	CntrSel	CntrSel = 0b00 for a bad running disparity counter. CntrSel = 0b01 for a not in table error counter. CntrSel = 0b10 for an unexpected control character counter.

### Check for Error Count over Threshold

In addition to reading the error count per lane and error type as described in the Checking Error Counts section, the user can check a register to see if the error count for a given error type has reached a programmable threshold.

The same error threshold is used for the three error types (disparity, not in table, and unexpected control character).

The error counters are on a per error type basis. To use this feature, complete the following steps:

1. Program the desired error count threshold into ERRORTHRES (Register 0x47C).
2. Read back the error status for each error type to see if the error count has reached the error threshold.
  - Disparity errors are reported in Register 0x46D.
  - Not in table errors are reported in Register 0x46E.
  - Unexpected control character errors are reported in Register 0x46F.

### Error Counter and IRQ Control

The user can write to Register 0x46D and Register 0x46F to reset or disable the error counts and to reset the IRQ for a given lane. Note that these are the same registers that report error count over threshold (see the Check for Error Count over Threshold section); thus, the readback is not the value that was written. For each error type,

1. Decide whether to reset the IRQ, disable the error count, and/or reset the error count for the given lane and error type.
2. Write the lane and desired reset or disable action to Register 0x46D to Register 0x46F according to Table 53.

**Table 53. Error Counter and IRQ Control: Disparity (Register 0x46D), Not in Table (Register 0x46E), and Unexpected Control Character (Register 0x46F)**

Bits	Variable	Description
7	RstIRQ	RstIRQ = 1 to reset IRQ for the lane selected in Bits[2:0].
6	Disable_ErrCnt	Disable_ErrCnt = 1 to disable the error count for the lane selected in Bits[2:0].
5	RstErrCntr	RstErrCntr = 1 to reset the error count for the lane selected in Bits[2:0].
[2:0]	LaneAddr	LaneAddr = x to monitor the error count of Lane x.

### Monitoring Errors via SYNCOUT±

When one or more disparity, not in table, or unexpected control character error occurs, the error is reported on the SYNCOUT± pins per Section 7.6 of the JESD204B specification. The JESD204B specification states that the SYNCOUT± signal is asserted for exactly two frame periods when an error occurs. For the AD9152, the width of the SYNCOUT± pulse can be programmed to ½, 1, or 2 PClock cycles. The settings to achieve a SYNCOUT± pulse of two frame clock cycles are given in Table 54.

**Table 54. Setting SYNCOUT± Error Pulse Duration**

JESD204B Mode IDs	PClockFactor (Frames/PClock)	SYN_CB_ERR_DUR (Register 0x312, Bits[7:4]) Setting <sup>1</sup>
4, 9	4	0 (default)
5, 6, 10	2	1
7	1	2

<sup>1</sup> These register settings assert the SYNCOUT± signal for two frame clock cycle pulse widths.

### Disparity, Not in Table, and Unexpected Control Character IRQs

For disparity, not in table, and unexpected control character errors, error count over the threshold events are available as IRQ events. Enable these events by writing to Register 0x47A, Bits[7:5]. The IRQ event status can be read at the same address (Register 0x47A, Bits[7:5]) after the IRQs are enabled.

See the Error Counter and IRQ Control section for information on resetting the IRQ. See the Interrupt Request Operation section for more information on IRQs.

#### Errors Requiring Reinitializing

A link reinitialization automatically occurs when four invalid disparity character errors are received, per Section 7.1 of the JESD204B specification. When a link reinitialization occurs, the resync request is five frames and nine octets long.

The user can optionally reinitialize the link when the error count for disparity errors, not in table errors, or unexpected control characters reaches a programmable error threshold. The process to enable the reinitialization feature for certain error types is as follows:

1. Set THRESHOLD\_MASK\_EN (Register 0x477, Bit 3) = 1. Note that when this bit is set, unmasked errors do not saturate at either threshold or maximum value.
2. Enable the sync assertion mask for each type of error by writing to the SYNCASSERTIONMASK register (Register 0x47B, Bits[7:5]) according to Table 55.
3. Program the desired error counter threshold into ERRORTHRES (Register 0x47C).
4. For each error type enabled in the SYNCASSERTIONMASK register, if the error counter on any lane reaches the programmed threshold, SYNCOUT± falls, issuing a sync request. Note that all error counts are reset when a link reinitialization occurs. The IRQ does not reset and must be reset manually.

**Table 55. Sync Assertion Mask**

Addr.	Bit No.	Bit Name	Description
0x47B	7	BADDIS_S	Set to 1 to assert SYNCOUT± if the disparity error count reaches the threshold
	6	NIT_S	Set to 1 to assert SYNCOUT± if the not in table error count reaches the threshold
	5	UCC_S	Set to 1 to assert SYNCOUT± if the unexpected control character count reaches the threshold

### CGS, Frame Sync, Checksum, and ILAS Monitoring

Register 0x470 to Register 0x473 can be monitored to verify that each stage of the JESD204B link establishment has occurred.

Bit x of CODEGRPSYNCFLAG (Register 0x470) is high if Lane x received at least four K28.5 characters and passed code group synchronization.

Bit x of FRAMESYNCFLAG (Register 0x471) is high if Lane x completed initial frame synchronization.

Bit x of GOODCHKSUMFLG (Register 0x472) is high if the checksum sent over the lane matches the sum of the JESD204B parameters sent over the lane during ILAS for Lane x. The parameters can be added either by summing the individual fields in the registers or summing the packed register. If Register 0x300, Bit 6 = 0 (default), the calculated checksums are the lower eight bits of the sum of the following fields: DID, BID, LID, SCR, L – 1, F – 1, K – 1, M – 1, N – 1, SUBCLASSV, NP – 1, JESDV, S – 1, and HD. If Register 0x300, Bit 6 = 1, the calculated checksums are the lower eight bits of the sum of Register 0x400 to Register 0x40C and LID (Register 0x412, Register 0x41A, and Register 0x422).

Bit x of INITIALLANESYNC (Register 0x473) is high if Lane x passed the initial lane alignment sequence.

#### CGS, Frame Sync, Checksum, and ILAS IRQs

Fail signals for CGS, frame sync, checksum, and ILAS are available as IRQ events. To enable them, write to Register 0x47A, Bits[3:0]. The IRQ event status can be read at the same address (Register 0x47A, Bits[3:0]) after the IRQs are enabled. To reset the CGS IRQ, write 1 to Bit 7 of Register 0x470. To reset the frame sync IRQ, write 1 to Bit 7 of Register 0x471. To reset the checksum IRQ, write 1 to Bit 7 of Register 0x472. To reset the ILAS IRQ, write 1 to Bit 7 of Register 0x473. See the Interrupt Request Operation section for more information.

#### Configuration Mismatch IRQ

The AD9152 has a configuration mismatch flag that is available as an IRQ event. Use Register 0x47B, Bit 3 to enable the mismatch flag (it is enabled by default), and then use Register 0x47B, Bit 4 to read back its status and reset the IRQ signal. See the Interrupt Request Operation section for more information.

The configuration mismatch event flag is high when the link configuration settings in Register 0x450 to Register 0x45D do not match the JESD204B transmitted settings (Register 0x400 to Register 0x40D).

Note that this function is different from the good checksum flags in Register 0x472. The good checksum flags ensure that the transmitted checksum matches a calculated checksum based on the transmitted settings. The configuration mismatch event ensures that the transmitted settings match the configured settings.

## DIGITAL DATAPATH

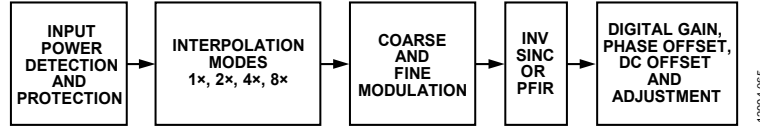

Figure 60. Block Diagram of the Digital Datapath

The block diagram in Figure 60 shows the functionality of the digital datapath (all blocks can be bypassed). The digital processing includes an input power detection block, three half-band interpolation filters, a quadrature modulator consisting of a fine resolution NCO and  $f_{DAC}/4$  and  $f_{DAC}/8$  coarse modulation block, an inverse sinc filter, and gain, phase, offset, and group delay adjustment blocks.

The interpolation filters take independent I and Q data streams. If using the modulation function, I and Q must be quadrature data to function properly.

Note that the pipeline delay changes when digital datapath functions are enabled/disabled. If fixed DAC pipeline latency is desired, do not reconfigure these functions after initial configuration.

### DATA FORMAT

BINARY\_FORMAT (Register 0x110, Bit 7) controls the expected input data format. By default it is 0, which means the input data must be in twos complement. It can also be set to 1, which means input data is in offset binary (0x0000 is negative full scale and 0xFFFF is positive full scale).

### INTERPOLATION FILTERS

The transmit path contains three half-band interpolation filters, which each provide a 2× increase in output data rate and a low-pass function. The filters can be cascaded to provide a 4× or 8× interpolation ratio. Table 56 shows how to select each available interpolation mode, their usable bandwidths, and their maximum data rates. Note that  $f_{DATA} = f_{DAC}/\text{InterpolationFactor}$ . Register 0x030, Bit 0 is high if an unsupported interpolation mode is selected.

Table 56. Interpolation Modes and Usable Bandwidth

Interpolation Mode	INTERP_MODE Reg. 0x112[2:0]	Usable Bandwidth	Maximum $f_{DATA}$ (MHz)
1× (Bypass)	0x00	$0.5 \times f_{DATA}$	1238 <sup>1</sup>
2×	0x01	$0.4 \times f_{DATA}$	1125
4×	0x02	$0.4 \times f_{DATA}$	562.5
8×	0x03	$0.4 \times f_{DATA}$	281.25

<sup>1</sup> The maximum speed for 1× interpolation mode is limited by the JESD204B interface.

### Filter Performance

The interpolation filters interpolate between existing data in such a way that they minimize changes in the incoming data while suppressing the creation of interpolation images. This is shown for each filter in Figure 61.

The usable bandwidth (as shown in Table 56) is defined as the frequency band over which the filters have a pass-band ripple of less than  $\pm 0.001$  dB and an image rejection of greater than 85 dB.

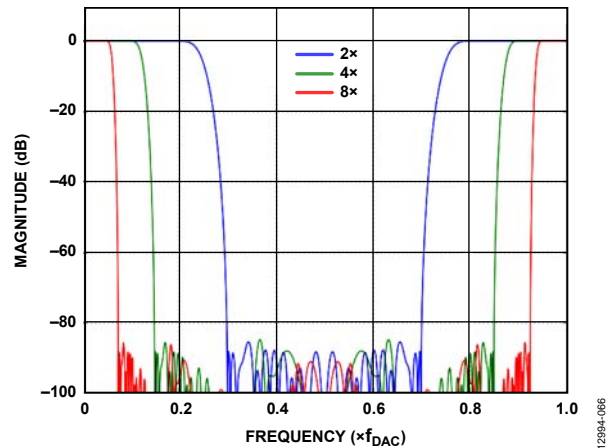

Figure 61. All Band Responses of Interpolation Filters

### Filter Performance Beyond Specified Bandwidth

The interpolation filters are specified to  $0.4 \times f_{DATA}$  (with pass band). The filters can be used slightly beyond this ratio at the expense of increased pass-band ripple and decreased interpolation image rejection.

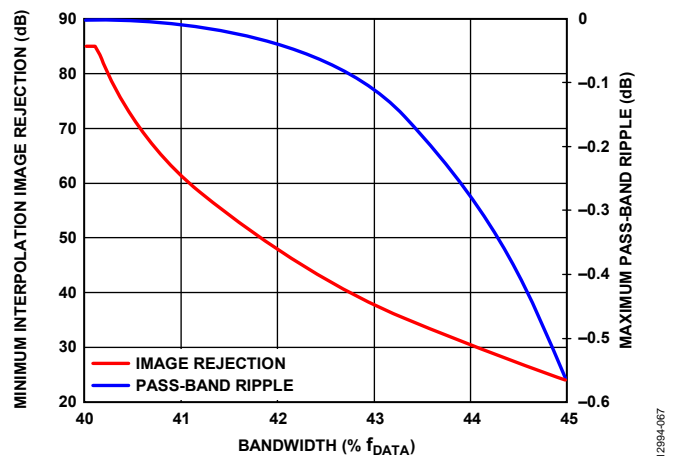

Figure 62. Interpolation Filter Performance Beyond Specified Bandwidth

Figure 62 shows the performance of the interpolation filters beyond  $0.4 \times f_{DATA}$ . Note that the ripple increases much slower than the image rejection decreases. This means that if the application can tolerate degraded image rejection from the interpolation filters, more bandwidth can be used.

**DIGITAL MODULATION**

The AD9152 provides two modes to modulate the baseband quadrature signal to the desired DAC output frequency.

- $f_{DAC}/4$  and  $f_{DAC}/8$  coarse modulation
- NCO fine modulation

The coarse modulation modes ( $f_{DAC}/4$  and  $f_{DAC}/8$ ) allow modulation by those particular frequencies. The NCO fine modulation mode allows modulating by a programmable frequency at the cost of higher power consumption, depending on the DAC rate. Modulation mode is selected as shown in Table 57.

**Table 57. Modulation Mode Selection**

Modulation Mode	MODULATION_TYPE, Register 0x111, Bits[3:2]
None	0b00
NCO Fine Modulation	0b01
Coarse, $f_{DAC}/4$	0b10
Coarse, $f_{DAC}/8$	0b11

Based on the difference of direct digital synthesis (DDS) accumulator, NCO modulation has the following two modes:

- Typical accumulator-based DDS (see the NCO Fine Modulation section)
- Programmable modulus DDS (see the Programmable Modulus DDS section)

**$f_{DAC}/4$  and  $f_{DAC}/8$  Modulation**

The  $f_{DAC}/4$  and  $f_{DAC}/8$  modulation are common modulation modes to translate the input baseband frequency to a fixed  $f_{DAC}/4$  or  $f_{DAC}/8$  IF frequency. These coarse modulation are selected by setting Bits[3:2] in Register 0x111. These modes provide lower power modulation frequencies of 1/4 or 1/8 of the DAC sampling rate. When modulation frequencies other than this frequency are required, the NCO modulation mode must be used.

**NCO Fine Modulation**

This modulation mode uses an NCO, a phase shifter, and a complex modulator to modulate the signal by a programmable carrier signal as shown in Figure 63. This allows output signals to be placed anywhere in the output spectrum with very fine frequency resolution.

The NCO produces a quadrature carrier to translate the input signal to a new center frequency. A quadrature carrier is a pair of sinusoidal waveforms of the same frequency, offset 90° from each other. The frequency of the quadrature carrier is set via an FTW. The quadrature carrier is mixed with the I and Q data and then summed into the I and Q datapaths, as shown in Figure 63.

$$-f_{DAC}/2 \leq f_{CARRIER} < +f_{DAC}/2$$

$$FTW = (f_{CARRIER}/f_{DAC}) \times 2^{48}$$

where FTW is a 48-bit, twos complement number.

The FTW is set as shown in Table 58.

**Table 58. NCO FTW Registers**

Address	Value	Description
0x114	FTW[7:0]	8 LSBs of FTW
0x115	FTW[15:8]	Next 8 bits of FTW
0x116	FTW[23:16]	Next 8 bits of FTW
0x117	FTW[31:24]	Next 8 bits of FTW
0x118	FTW[39:32]	Next 8 bits of FTW
0x119	FTW[47:40]	8 MSBs of FTW

Unlike other registers, the FTW registers are not updated immediately upon writing. Instead, the FTW registers update on the rising edge of FTW\_UPDATE\_REQ (Register 0x113, Bit 0). After an update request, FTW\_UPDATE\_ACK (Register 0x113, Bit 1) must be high to acknowledge that the FTW has updated.

SEL\_SIDE BAND (Register 0x111, Bit 1) is a convenience bit that can be set to use the negative modulation result. This is equivalent to flipping the sign of FTW. SEL\_SIDE BAND also applies to  $f_s/4$  and  $f_s/8$  modulation.

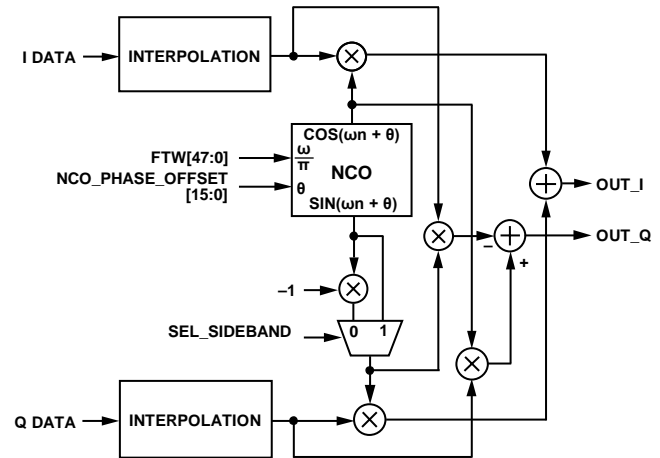

Figure 63. NCO Fine Modulator Block Diagram

**NCO Phase Offset**

The phase offset feature allows rotation of the I and Q phases. Unlike phase adjust, this feature moves the phases of both I and Q channels together. Phase offset can be used only when using NCO fine modulation.

$$-180^\circ \leq \text{DegreesOffset} < +180^\circ$$

$$\text{PhaseOffset} = (\text{DegreesOffset}/180^\circ) \times 2^{15}$$

where PhaseOffset is a 16-bit, twos complement number.

The NCO phase offset is set as shown in Table 59. Because this function is part of the fine modulation block, phase offset is not updated immediately upon writing. Instead, it updates on the rising edge of FTW\_UPDATE\_REQ (Register 0x113, Bit 0), along with the FTW.

**Table 59. NCO Phase Offset Registers**

Address	Value
0x11A	NCO_PHASE_OFFSET[7:0]
0x11B	NCO_PHASE_OFFSET[15:8]

### Programmable Modulus DDS

The programmable modulus is a modification of the typical accumulator-based DDS architecture (NCO). The frequency ratio for the programmable modulus DDS is very similar to that of the typical accumulator-based DDS. The only difference is that N is not required to be a power of two for the programmable modulus, but can be an arbitrary integer. In practice, hardware constraints place limits on the range of values for N. As a result, it extends the use of DDS to applications that require exact rational frequency synthesis. The underlying function of the programmable modulus technique is to alter the accumulator modulus.

Implementation of the programmable modulus function within the AD9152 is such that the fraction, M/N, is expressible per the equation below. Note that the form of the equation implies a compound frequency tuning word with X representing the integer part and A/B representing the fractional part.

$$\frac{f_{\text{CARRIER}}}{f_{\text{DAC}}} = \frac{M}{N} = \frac{X + \frac{A}{B}}{2^{48}}$$

where:

X is programmed in Register 0x114 to Register 0x119.

A is programmed in Register 0x158 to Register 0x15D.

B is programmed in Register 0x152 to Register 0x157.

### Programmable Modulus Example

Consider the case in which  $f_{\text{DAC}} = 250$  MHz and the desired value of  $f_{\text{CARRIER}}$  is 25 MHz. This scenario synthesizes an output frequency that is not a power of two submultiple of the sample rate, namely  $f_{\text{CARRIER}} = (1/10) f_{\text{DAC}}$ , which is not possible with a typical accumulator-based DDS. The frequency ratio,  $f_{\text{CARRIER}}/f_{\text{DAC}}$ , leads directly to M and N, which are determined by reducing the fraction (25,000,000/250,000,000) to its lowest terms. That is,

$$M/N = 25,000,000/250,000,000 = 1/10$$

Therefore, M = 1 and N = 10. After calculation, X = 429,496,729; A = 3; and B = 5. Programming these values into the registers causes the modulus DDS to produce an output frequency of exactly 25 MHz, given a 250 MHz sampling clock. For more details, see the [AN-953 Application Note](#).

### NCO ALIGNMENT

The NCO alignment block phase aligns the NCO output from multiple converters. Two NCO alignment modes are supported by the AD9152. The first is a SYSREF± alignment mode that phase aligns the NCO outputs to the rising edge of a SYSREF± pulse. The second alignment mode is a data key alignment; when this mode is enabled, the AD9152 aligns the NCO outputs when a user specified data pattern arrives at the DAC input.

#### SYSREF± NCO Alignment

As with the LMFC alignment, in Subclass 1, a SYSREF± pulse phase aligns the NCO outputs of multiple devices in a system and multiple channels on the same device. Note that in Subclass 0, this alignment mode can be used to align the NCO outputs within a device to an internal processing clock edge. No

SYSREF± edge is needed in Subclass 0, but multichip alignment cannot be achieved. The steps to achieve a SYSREF± NCO alignment are as follows:

1. Set NCO\_ALIGN\_MODE (Register 0x050, Bits[1:0] = 0b01) for SYSREF± NCO alignment mode.
2. Set NCO\_ALIGN\_ARM (Register 0x050, Bit 7) to 1.
3. Perform an LMFC alignment to force the NCO phase align (see the Syncing LMFC Signals section). The phase alignment occurs on the next SYSREF± edge. Note that if in one shot sync mode, the LMFC alignment block must be armed by setting Register 0x03A, Bit 6 = 1. If in continuous mode or one shot then monitor mode, the LMFC align block does not need to be armed; the NCO align automatically trips on the next SYSREF± edge.
4. Check the alignment status. If NCO phase alignment was successful, NCO\_ALIGN\_PASS (Register 0x050, Bit 4) = 1. If phase alignment failed, NCO\_ALIGN\_FAIL (Register 0x050, Bit 3) = 1.

#### Data Key NCO Alignment

In addition to supporting the SYSREF± alignment mode, the AD9152 supports a mode in which the NCO phase alignment occurs when a user-specified pattern is seen at the DAC input. The steps to achieve a data key NCO alignment are as follows:

1. Set NCO\_ALIGN\_MODE (Register 0x050, Bits[1:0]) to 0b10.
2. Write the expected 16-bit data key for the I and Q datapath into NCOKEYI[15:0] (Register 0x051 to Register 0x052) and NCOKEYQ[15:0] (Register 0x053 to Register 0x054), respectively.
3. Set NCO\_ALIGN\_ARM (Register 0x050, Bit 7) to 1.
4. Send the expected 16-bit I and Q data keys to the device to achieve NCO alignment.
5. Check the alignment status. If the expected data key was seen at the DAC input, NCO\_ALIGN\_MTCH (Register 0x050, Bit 5) = 1. If NCO phase alignment was successful, NCO\_ALIGN\_PASS (Register 0x050, Bit 4) = 1. If phase alignment failed, NCO\_ALIGN\_FAIL (Register 0x050, Bit 3) = 1.

Multiple device NCO alignment can be achieved with the data key alignment mode. To achieve multichip NCO alignment, program the same expected data key on all devices, arm all devices, and then send the data key to all devices/channels at the same time.

#### NCO Alignment IRQ

An IRQ event showing whether the NCO align was tripped is available. Use Register 0x021, Bit 4 to enable the IRQ and then use Register 0x025, Bit 4 to read back its status and reset the IRQ signal. See the Interrupt Request Operation section for details.

### INVERSE SINC

The AD9152 provides a digital inverse sinc filter to compensate the DAC roll-off over frequency. The filter is enabled by setting the INVSINC\_ENABLE bit (Register 0x111, Bit 7) and is disabled by default.

The inverse sinc ( $\text{sinc}^{-1}$ ) filter is a seven-tap FIR filter. Figure 64 shows the frequency response of  $\text{sin}(x)/x$  roll-off, the inverse sinc filter, and the composite response. The composite response has less than  $\pm 0.05$  dB pass-band ripple up to a frequency of  $0.4 \times f_{\text{DAC}}$ . To provide the necessary peaking at the upper end of the pass band, the inverse sinc filter shown has an intrinsic insertion loss of approximately 3.8 dB; in many cases, this can be partially compensated as described in the Digital Gain section.

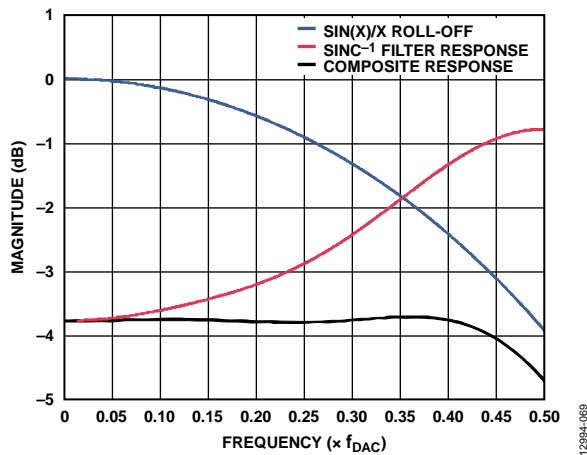

Figure 64. Responses of  $\text{sin}(x)/x$  Roll-Off, the  $\text{Sinc}^{-1}$  Filter, and the Composite of the Two Input Signal Power Detection and Protection

### PROGRAMMABLE FIR FILTER (PFIR)

The PFIR is a seven-tap FIR filter, which can be programmed through the registers to compensate the gain nonflatness of RF signal chain.

The PFIR is in parallel with INVSINC and is a superset of INVSINC. Do not enable the PFIR and INVSINC at the same time. A detailed specification of the PFIR filter follows:

- The coefficients are in 1.8 format, one sign bit, 8 resolution bits, and range from  $-1$  to  $+1$ . Set the coefficients in Register 0x17A to Register 0x181.
- Symmetry coefficients.
- The PFIR works with programmable coefficients with 0 dB to 6 dB gain at the filter output. To avoid signal overflow, set the filter to less than 6 dB gain. A gain of  $-6$  dB is applied at the PFIR output to bring it back to avoid overflow on the following blocks. However, the gain loss here can be easily compensated at the final digital gain stages. See the Digital Gain section.
- The PFIR can be turned off to save power.

### DIGITAL GAIN, PHASE ADJUST, DC OFFSET, AND COARSE GROUP DELAY

Digital gain, phase adjust, and dc offset (as described in the Digital Gain section, Phase Adjust section, and DC Offset section) allow compensation of imbalances in the I and Q paths due to analog mismatches between I/Q DAC outputs, quadrature modulator I/Q baseband inputs, and DAC/modulator interface I/Q paths. These imbalances can cause the two following issues:

- An unwanted sideband signal to appear at the quadrature modulator output with significant energy. This can be tuned out using digital gain and phase adjust. Tuning the quadrature gain and phase adjust values can optimize complex image rejection in single sideband radios or can optimize the error vector magnitude (EVM) in zero IF (ZIF) architectures.
- The dc offset can cause LO leakage through a modulator, which can be compensated with the offset feature in the DAC.

Coarse group delay allows adjustment of the delay through the DAC, which can be used to adjust digital predistortion (DPD) loop delay.

#### Digital Gain

Digital gain can be used to independently adjust the digital signal magnitude being fed into each DAC. This is useful to balance the gain between I and Q channels of a dual or to cancel out the insertion loss of the inverse sinc filter. Digital gain must be enabled when using the blanking state machine (see the Downstream Protection section). If digital gain is disabled, TXENx must be tied high.

Digital gain is enabled by setting the DIG\_GAIN\_ENABLE bit (Register 0x111, Bit 5). In addition to enabling the function, the amount of digital gain (GainCode) desired must be programmed. By default, digital gain is enabled and GainCode = 0x800, which means 0 dB gain.

$$0 \leq \text{Gain} \leq 4095/2048$$

$$-\infty \text{ dB} \leq \text{dBGain} \leq 6.018 \text{ dB}$$

$$\text{Gain} = \text{GainCode} \times (1/2048)$$

$$\text{dBGain} = 20 \times \log_{10}(\text{Gain})$$

$$\text{GainCode} = 2048 \times \text{Gain} = 2048 \times 10^{\text{dBGain}/20}$$

where GainCode is a 12-bit, unsigned binary number.

The I/Q digital gain is set as shown in Table 60.

Table 60. Digital Gain Registers

Addr.	Value	Description
0x111[5]	DIG_GAIN_ENABLE	Set to 1 to enable digital gain
0x13C	IDAC_DIG_GAIN[7:0]	I DAC LSB gain code
0x13D	IDAC_DIG_GAIN[11:8]	I DAC MSB gain code
0x13E	QDAC_DIG_GAIN[7:0]	Q DAC LSB gain code
0x13F	QDAC_DIG_GAIN[11:8]	Q DAC MSB gain code

### Phase Adjust

Ordinarily, the I and Q channels of each DAC pair have an angle of 90° between them. The phase adjust feature changes the angle between the I and Q channels, which can help balance the phase into a modulator.

$$-14 \leq \text{DegreesAdjust} < 14$$

$$IQPhaseAdj = (\text{DegreesAdjust}/14) \times 2^{12}$$

where  $IQPhaseAdj$  is a 13-bit, twos complement number.

The phase adjust is set as shown in Table 61.

**Table 61. I/Q Phase Adjustment Registers**

Addr.	Value	Description
0x111[4]	PHASE_ADJ_ENABLE	Set to 1 to enable phase adjust
0x11C	PHASE_ADJ[7:0]	LSB phase adjust code
0x11D	PHASE_ADJ[12:8]	MSB phase adjust code

### DC Offset

The dc offset feature individually offsets the data into the I or Q DACs. This can be used to cancel LO leakage.

The offset is programmed individually for I and Q as a 16-bit twos complement number in LSBs, plus a 5-bit, twos complement number in sixteenths of an LSB, as shown in Table 62.

$$-2^{15} \leq \text{LSBsOffset} < 2^{15} - 1$$

$$-16/16 \text{ LSB} \leq \text{SixteenthsOffset} \leq 15/16 \text{ LSB}$$

**Table 62. DC Offset Registers**

Addr.	Value	Description
0x135[0]	DC_OFFSET_ON	Set to 1 to enable dc offset
0x136	LSB_OFFSET_I[7:0]	I DAC LSB dc offset code
0x137	LSB_OFFSET_I[15:8]	I DAC MSB dc offset code
0x138	LSB_OFFSET_Q[7:0]	Q DAC LSB dc offset code
0x139	LSB_OFFSET_Q[15:8]	Q DAC MSB dc offset code
0x13A	SIXTEENTH_OFFSET_I	I DAC sub-LSB dc offset code
0x13B	SIXTEENTH_OFFSET_Q	Q DAC sub-LSB dc offset code

Figure 65 shows how the DAC output currents vary as a function of the  $LSBsOffset$  value. With the digital inputs fixed at midscale (0x0000, twos complement data format), Figure 65 shows the nominal current of the positive node of the DAC output,  $I_{IOUT+}/I_{QOUT+}$ , as the DAC offset value is swept from 0 to 65,535. Because  $I_{IOUT+}/I_{QOUT+}$  and  $I_{IOUT-}/I_{QOUT-}$  are complementary current outputs, the sum of  $I_{IOUT+}$  and  $I_{IOUT-}$  or  $I_{QOUT+}$  and  $I_{QOUT-}$  is always 20 mA.

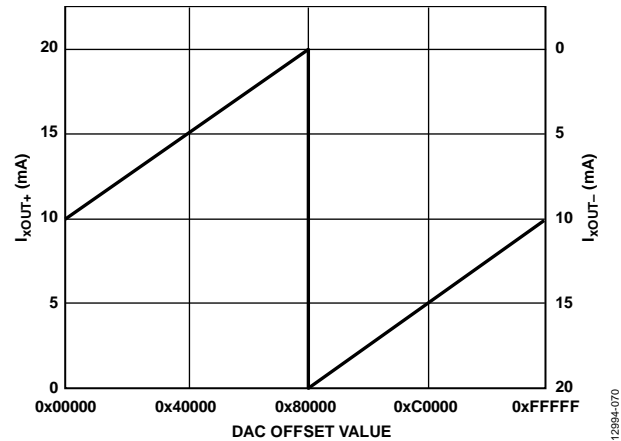

Figure 65. DAC Output Currents vs. DAC Offset Value

### Coarse Group Delay Adjustment

Coarse group delay is programmed in Register 0x047. The range of the delay is -4 DAC clock periods to +3 DAC clock periods and the resolution is 1/2 DAC clock period. Coarse group delay can be used for DPD loop delay adjustment.

## DOWNSTREAM PROTECTION

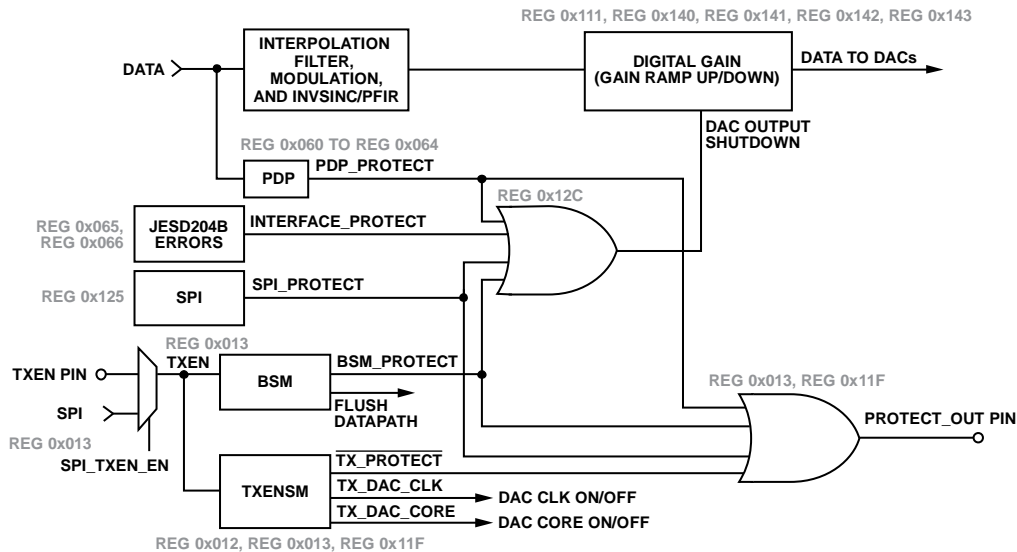

Figure 66. Downstream Protection Block Diagram

12994-166

The AD9152 has several blocks designed to protect the power amplifier (PA) of the system, as well as other downstream blocks. First, the DAC output can be shut down by tuning the digital gain that is automatically triggered by the following signals: PDP\_PROTECT, INTERFACE\_PROTECT, SPI\_PROTECT, and BSM\_PROTECT. Second, an external pin (PROTECT\_OUT) can be used to shut down external components. The PROTECT\_OUT pin is triggered by the following signals: PDP\_PROTECT, INTERFACE\_PROTECT, SPI\_PROTECT, and TX\_PROTECT.

The downstream protection function largely consists of a power detection and protection (PDP) block, a blanking state machine (BSM), and a transmit enable state machine (TXENSM).

The PDP block can be used to monitor incoming data. If a moving average of the data power goes above a threshold, the PDP block provides a signal (PDP\_PROTECT) that can be routed externally and turn off the DAC output gradually by tuning the digital gain.

The TXENSM block controls the delay between TXEN and the Tx\_PROTECT signals. At the same time, the Tx\_PROTECT signal can optionally be routed externally to the PROTECT\_OUT pin, and the TXENSM can also generate the TX\_DAC\_CLK signal and TX\_DAC\_CORE signal to power down the DAC clock and the DAC core.

The BSM block flushes the datapath and turns the DAC output on or off by tuning the digital gain that is triggered by BSM\_PROTECT, which can also be routed to the external PROTECT\_OUT pin. BSM\_PROTECT follows the status of TXEN.

TXEN can come from the external TXEN pin or the SPI, which is selected by SPI\_TXEN\_EN (Register 0x013, Bit 1).

**Power Detection and Protection**

The input signal PDP block detects the average power of the DAC input signal and prevents overrange signals from being passed to the next stage, which may potentially cause destructive breakdown on power sensitive devices, such as PAs. The protection function provides a signal (PDP\_PROTECT) that can be routed externally to shut down a PA and shut down the DAC output.

The PDP block uses a separate path with a shorter latency than the datapath to ensure that PDP\_PROTECT is triggered before the overrange signal reaches the analog DAC cores. The sum of the  $I^2$  and  $Q^2$  are calculated as a representation of the input signal power (only the top six MSBs of data samples are used). The calculated sample power numbers are accumulated through a moving average filter whose output is the average of the input signal power in a certain number of samples.

When the output of the averaging filter is larger than the threshold, the internal signal PDP\_PROTECT goes high, which can optionally be configured to trigger a signal on the PROTECT\_OUT pin and turn off the DAC output through digital gain.

The choice of PDP\_AVG\_TIME (Register 0x062) and PDP\_THRESHOLD (Register 0x060 to Register 0x061) for effective protection are application dependent. Experiment with real-world vectors to ensure proper configuration. The PDP\_POWER readback (Register 0x063 to Register 0x064) can help by storing the maximum power when a set threshold is passed. The PDP block is configured as shown in Table 63.

Table 63. PDP Registers

Addr.	Bit No.	Value	Description
0x060	[7:0]	PDP_THRESHOLD[7:0]	Power that triggers PDP_PROTECT. 8 LSBs.
0x061	[4:0]	PDP_THRESHOLD[12:8]	5 MSBs.
0x062	7	PDP_ENABLE	Set to 1 to enable PDP.
	[3:0]	PDP_AVG_TIME	Can be set from 0 to 10. Averages across $2^{(9 + \text{PDP\_AVG\_TIME})}$ , IQ sample pairs.
0x063	[7:0]	PDP_POWER[7:0]	If PDP_THRESHOLD is crossed, this reads back the maximum power seen. If not, this reads back the instantaneous power. 8 LSBs.
0x064	[4:0]	PDP_POWER[12:8]	5 MSBs.
0x12C	7	PROTECT_MODE	If this bit is high, the DAC is in protect mode, and is shut down automatically when some errors occur.
	0	DACOFF_AVG_PW	If this bit is high, Bit 7 is high, and the input average power is greater than the given threshold (see Register 0x060 and Register 0x061) within a given time window, the DAC output shuts down automatically.
0x013	6	PDP_PROTECT_OUT	1: PDP_PROTECT triggers PROTECT_OUT.

### Power Detection and Protection IRQ

The PDP\_PROTECT signal is available as an IRQ event.

Use Register 0x021, Bit 7 to enable PDP\_PROTECT and then use Register 0x025, Bit 7 to read back its status and reset the IRQ signal.

See the Interrupt Request Operation section for more information.

### Transmit Enable State Machine

The TXENSM block controls the delay between TXEN and the Tx\_PROTECT signals. At the same time, the Tx\_PROTECT signal can optionally be routed externally to the PROTECT\_OUT pin and the TXENSM can generate the TX\_DAC\_CLK signal and TX\_DAC\_CORE signal to power down the DAC clock and DAC core.

If DACA\_MASK (Register 0x012, Bit 6) = 1, a falling edge of TXEN causes the DAC core I DAC and Q DAC to power down; a rising edge of TXEN causes the DAC core I DAC and Q DAC to power up.

If CLKA\_MASK (Register 0x012, Bit 4) = 1, a falling edge of TXEN causes the DAC clock to power down; a rising edge of TXEN causes the DAC clock to power up.

The TXENSM is configured as shown in Table 64.

Table 64. TXENSM Registers

Addr.	Bit No.	Value	Description
0x012	6	DACA_MASK	DAC core power-down mask for TXEN.
	4	CLKA_MASK	Datapath power-down mask for TXEN.
0x013	5	TX_PROTECT_OUT	1: TX_PROTECT triggers PROTECT_OUT.
0x11F	0	TXEN_SM_EN	If high, enable TXEN state machine.

### TXENSM Startup Sequence

To ensure that the TXENSM functions properly, the following sequence must be used. Excepting Register 0x012 and Register 0x013, other registers must follow the recommend values in Table 65.

Table 65. TXENSM Startup Sequence<sup>1</sup>

Addr.	Value	Description
0x012	0x00	Enable the DAC core and datapath power-down mask
0x013	0x20	TX_PROTECT triggers PROTECT_OUT
0x140	0x04	Gain ramp up step
0x142	0x09	Gain ramp down step
0x11F	0x83	Enable the TXEN state machine

<sup>1</sup> Perform these writes in the order they are listed in this table.

After applying the sequence in Table 65, the function of the TXENSM timing is shown in Figure 67.

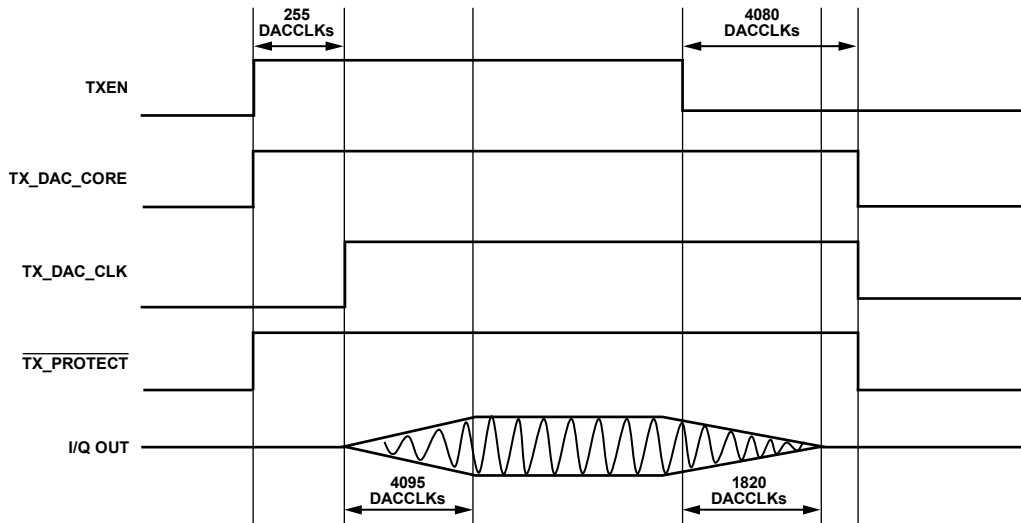

Figure 67. TXENSM Timing

12994-167

**Blanking State Machine (BSM)**

The BSM block flushes the datapath and turns the DAC output on or off through the digital gain and is triggered by BSM\_PROTECT, which can also be routed to the external PROTECT\_OUT pin. BSM\_PROTECT follows the status of TXEN. The BSM is configured as shown in Table 66.

Table 66. TXENSM Registers

Addr.	Bit No.	Value	Description
0x013	4	BSM_PROTECT_OUT	1: BSM triggers PROTECT_OUT

**Shutdown DAC Output**

The DAC output can be shut down gradually by tuning the digital gain that is automatically triggered by the following signals: PDP\_PROTECT, INTERFACE\_PROTECT, SPI\_PROTECT, and BSM\_PROTECT. For proper ramping, digital gain must be enabled. The step size to use when ramping the gain to 0 or its assigned value can be controlled via the GAIN\_RAMP\_DOWN\_STEP registers (Register 0x142 and Register 0x143) and the GAIN\_RAMP\_UP\_STEP registers (Register 0x140 and Register 0x141).

Besides the PDP block and the BSM block, certain JESD204B and SPI write errors can also be configured to shut down the DAC output when they occur using Register 0x065, Register 0x066, and Register 0x125.

**PROTECT\_OUT Generation**

Register 0x013 controls which signals are ORed into the external PROTECT\_OUT signal (see Table 67). Register 0x11F, Bit 2 can be used to invert the PROTECT\_OUT signal. By default, PROTECT\_OUT is high when the output is valid.

Table 67. PROTECT\_OUT Registers

Addr.	Bit No.	Value	Description
0x013	6	PDP_PROTECT_OUT	1: PDP_PROTECT triggers PROTECT_OUT
	5	TX_PROTECT_OUT	1: TX_PROTECT triggers PROTECT_OUT
	4	BSM_PROTECT_OUT	1: BSM_PROTECT triggers PROTECT_OUT
	3	SPI_PROTECT_OUT_EN	1: SPI_PROTECT triggers PROTECT_OUT
	2	SPI_PROTECT_OUT_CTRL	1: PROTECT_OUT is low
	1	SPI_TXEN_EN	1: TXEN is controlled by the SPI
	0	SPI_TXEN_CTRL	1: TXEN is high

**DATAPATH PRBS**

The datapath PRBS verifies that the AD9152 datapath is receiving and correctly decoding data. The datapath PRBS verifies that the JESD204B parameters of the transmitter and receiver match, the lanes of the receiver are mapped appropriately, lanes have been appropriately inverted, if necessary, and in general that the start-up routine has been implemented correctly. Note that the datapath PRBS function applies only to 2x, 4x, and 8x interpolation.

To run the datapath PRBS test, complete the following steps:

1. Set up the device in the desired operating mode. See the Device Setup Guide section for details on setting up the device.
2. Send the PRBS7 or PRBS15 data.
3. Write 0 to Register 0x14B, Bit 2 for PRBS7 or write 1 for PRBS15.
4. Write 0b11 to Register 0x14B, Bits[1:0] to enable and reset the PRBS test.
5. Write 0b01 to Register 0x14B, Bits[1:0] to enable the PRBS test and release reset.
6. Wait 500 ms.
7. Check the status by checking the IRQ for the I DAC and the Q DAC PRBS as described in the Datapath PRBS IRQ section.
8. Read Register 0x14B, Bits[7:6]. Bit 6 is 0 if the I DAC of the selected dual has any errors. Bit 7 is 0 if the Q DAC of the selected dual has any errors. This must match the IRQ.
9. Read Register 0x14C to read the error count for the I DAC. Read Register 0x14D to read the error count for the Q DAC.

Note that the PRBS processes 32 bits at a time, and compares the 32 new bits to the previous set of 32 bits. It detects (and reports) only 1 error in every group of 32 bits; therefore, the error count partly depends on when the errors are seen.

For example,

- Bits: 32 good, 31 good, 1 bad; 32 good (2 errors)
- Bits: 32 good, 22 good, 10 bad; 32 good (2 errors)
- Bits: 32 good, 31 good, 1 bad; 31 good, 1 bad; 32 good (3 errors)

#### **Datapath PRBS IRQ**

The PRBS fail signals for each DAC are available as IRQ events. Use Register 0x020, Bits[1:0] to enable the fail signals, and then use Register 0x02s[1:0] to read back their statuses and reset the IRQ signals. See the Interrupt Request Operation section for more information.

#### **DC TEST MODE**

As a convenience, the [AD9152](#) provides a dc test mode, which is enabled by setting Register 0x0F7, Bit 1. When this mode is enabled, the datapath is given 0 (midscale) for its data.

In conjunction with dc offset, this test mode can provide desired dc data to the DACs. This test mode can also provide sinusoidal data to the DACs by combining digital modulation (to set frequency) and dc offset (to set amplitude). See the DC Offset section.

## INTERRUPT REQUEST OPERATION

The AD9152 provides an interrupt request output signal on Pin 10 ( $\overline{\text{IRQ}}$ ) that can be used to notify an external host processor of significant device events. On assertion of the interrupt, query the device to determine the precise event that occurred.

The  $\overline{\text{IRQ}}$  pin is an open-drain, active low output. Pull the  $\overline{\text{IRQ}}$  pin high external to the device. This pin can be tied to the interrupt pins of other devices with open-drain outputs to wire; OR these pins together.

Figure 68 shows a simplified block diagram of how the  $\overline{\text{IRQ}}$  blocks works. If  $\text{IRQ\_EN}$  is low, the  $\text{INTERRUPT\_SOURCE}$  signal is set to 0. If  $\text{IRQ\_EN}$  is high, any rising edge of an event causes the  $\text{INTERRUPT\_SOURCE}$  signal to be set high. If any  $\text{INTERRUPT\_SOURCE}$  signal is high, the  $\overline{\text{IRQ}}$  pin is pulled low.  $\text{INTERRUPT\_SOURCE}$  can be reset to 0 by either an  $\overline{\text{IRQ}}$  reset signal or a device reset.

Depending on  $\text{STATUS\_MODE}$ , the  $\text{EVENT\_STATUS}$  bit reads back an event or  $\text{INTERRUPT\_SOURCE}$ . The AD9152 has several  $\overline{\text{IRQ}}$  register blocks that can monitor up to 48 events (depending on device configuration). Certain details vary by  $\overline{\text{IRQ}}$  register block as described in Table 68. Table 69 shows which registers the  $\text{IRQ\_EN}$ ,  $\text{IRQ\_RESET}$ , and  $\text{STATUS\_MODE}$  signals in Figure 68 originate from, as well as the address where  $\text{EVENT\_STATUS}$  is read back.

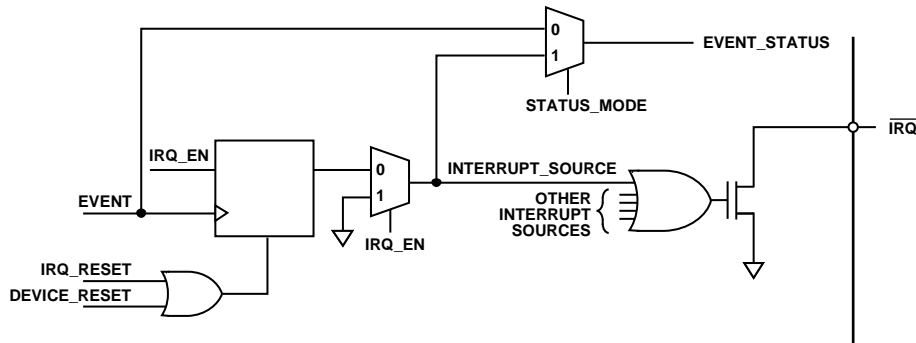

Figure 68. Simplified Schematic of  $\overline{\text{IRQ}}$  Circuitry

Table 69.  $\overline{\text{IRQ}}$  Register Block Address of  $\overline{\text{IRQ}}$  Signal Details

Register Block	Address of $\overline{\text{IRQ}}$ Signals			
	$\text{IRQ\_EN}$	$\text{IRQ\_RESET}$	$\text{STATUS\_MODE}$	$\text{EVENT\_STATUS}$
0x01F to 0x025	0x01F to 0x021; R/W per chip	0x023 to 0x025; W per chip	$\text{STATUS\_MODE} = \text{IRQ\_EN}$	0x023 to 0x025; R per chip
0x46D to 0x46F	0x47A; W per link	0x46D to 0x46F; W per link and lane	Not applicable, $\text{STATUS\_MODE} = 1$	0x47A; R per link
0x470 to 0x473	0x47A; W per link	0x470 to 0x473; W per link	Not applicable, $\text{STATUS\_MODE} = 1$	0x47A; R per link
0x47B, Bit 4	0x47B, Bit 3; R/W per link; 1 by default	0x47B, Bit 4; W per link	Not applicable, $\text{STATUS\_MODE} = 1$	0x47B, Bit 4; R per link

Table 68.  $\overline{\text{IRQ}}$  Register Block Details

Register Block	Event Reported	$\text{EVENT\_STATUS}$
0x01F to 0x025	Per chip	$\text{INTERRUPT\_SOURCE}$ if $\overline{\text{IRQ}}$ is enabled, if not, it is an event
0x46D to 0x46F; 0x470 to 0x473; 0x47A	Per link and lane	$\text{INTERRUPT\_SOURCE}$ if $\overline{\text{IRQ}}$ is enabled, if not, 0
0x47B, Bit 4	Per link	$\text{INTERRUPT\_SOURCE}$ if $\overline{\text{IRQ}}$ is enabled, if not, 0

## INTERRUPT SERVICE ROUTINE

Interrupt request management begins by selecting the set of event flags that require host intervention or monitoring. Enable the events that require host action so that the host is notified when they occur. For events requiring host intervention upon  $\overline{\text{IRQ}}$  activation, run the following routine to clear an interrupt request:

1. Read the status of the event flag bits that are being monitored.
2. Disable the interrupt by writing 0 to  $\text{IRQ\_EN}$ .
3. Read the event source. For Register 0x01F to Register 0x026,  $\text{EVENT\_STATUS}$  has a live readback. For other events, see their registers.
4. Perform any actions that may be required to clear the cause of the event. In many cases, no specific actions may be required.
5. Verify that the event source is functioning as expected.
6. Enable the interrupt by writing 1 to  $\text{IRQ\_EN}$ .
7. Clear the interrupt by writing 1 to  $\text{IRQ\_RESET}$ .

## DAC INPUT CLOCK CONFIGURATIONS

The AD9152 DAC sample clock (DACCLK) can be sourced directly through DACCLK± (Pin 48 and Pin 49) or by clock multiplication through the REFCLK± differential input (Pin 3 and Pin 4). Clock multiplying employs the on-chip PLL that accepts a reference clock operating at a submultiple of the desired DACCLK rate. The PLL then multiplies the reference clock up to the desired DACCLK frequency, which generates all the internal clocks required by the DAC. The clock multiplier provides a high quality clock that meets the performance requirements of most applications. Using the on-chip clock multiplier removes the burden of generating and distributing the high speed DACCLK.

The second mode bypasses the clock multiplier circuitry and allows the DACCLK to be sourced directly to the DAC core. This mode enables the user to source a very high quality clock directly to the DAC core.

### DRIVING THE DACCLK± AND REFCLK± INPUTS

The DACCLK± and REFCLK± differential inputs share similar clock receiver input circuitry, shown in Figure 69. The on-chip clock receiver has a differential input impedance of 10 kΩ. It is self biased to a common-mode voltage of approximately 600 mV. The inputs can be driven by differential PECL or LVDS drivers with ac coupling between the clock source and the receiver.

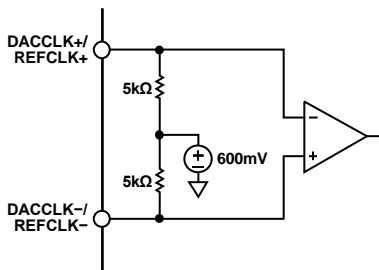

Figure 69. Simplified Equivalent Circuit of the Clock Receiver Input

The minimum input drive level to the differential clock input is 400 mV p-p differential. The optimal performance is achieved when the clock input signal is between 600 mV p-p differential and 800 mV p-p differential. Whether using the on-chip clock multiplier or sourcing the DACCLK directly, the input clock signal to the device must have low jitter and fast edge rates to optimize the DAC noise performance. Direct clocking with a low noise clock produces the lowest noise spectral density at the DAC outputs.

The clocks and clock receiver are powered down by default. The clocks must be enabled by writing to Register 0x011. To enable all clocks on the device, write 0x00 to Register 0x011.

## CONDITION SPECIFIC REGISTER WRITES

### Clock Multiplication Relationships

The on-chip PLL clock multiplier circuit generates the DAC sample rate clock from a lower frequency reference clock. The PLL is integrated on chip, including the VCO and the loop filter. The VCO operates over the frequency range of 6 GHz to 12 GHz.

The PLL configuration parameters must be programmed before the PLL is enabled. Step by step instructions on how to program the PLL can be found in the Temperature Tracking section. The functional block diagram of the clock multiplier is shown in Figure 70.

The clock multiplication circuit generates the DAC sampling clock from the REFCLK± input, which is fed in on the REFCLK± differential pins (Pin 3 and Pin 4). The frequency of the REFCLK± input is referred to as  $f_{REF}$ .

The REFCLK± input is divided by the variable RefDivFactor. Select the RefDivFactor variable to ensure that the frequency into the phase frequency detector (PFD) block is between 35 MHz and 80 MHz. The valid values for RefDivFactor are 2, 4, 8, 16, or 32. Each RefDivFactor maps to the appropriate REF\_DIV\_MODE register control according to Table 70. The REF\_DIV\_MODE register is programmed through Register 0x08C, Bits[2:0].

Table 70. Mapping of RefDivFactor to REF\_DIV\_MODE

DAC Reference Frequency Range (MHz)	Divide by Factor (RefDivFactor)	REF_DIV_MODE, Reg. 0x08C, Bits[2:0]
70 to 160	2	1
160 to 320	4	2
320 to 640	8	3
640 to 1000	16	4

The range of  $f_{REF}$  is 80 MHz to 1 GHz, and the output frequency of the PLL is 420 MHz to 2.25 GHz. Use the following equations to determine the RefDivFactor:

$$35 \text{ MHz} < \frac{f_{REF}}{\text{RefDivFactor}} < 80 \text{ MHz} \quad (1)$$

where:

$f_{REF}$  is the reference frequency on the REFCLK± input pins.

RefDivFactor is the reference divider division ratio.

The BCount value is the divide ratio of the loop divider. It is set to divide the  $f_{DAC}$  to frequency match the  $f_{REF}/\text{RefDivFactor}$ . Select BCount so that the following equation is true:

$$\frac{f_{DAC}}{2 \times \text{BCount}} = \frac{f_{REF}}{\text{RefDivFactor}} \quad (2)$$

where:

$f_{DAC}$  is the DAC sample clock.

BCount is the feedback loop divider ratio.

The BCount value is programmed with Bits[7:0] of Register 0x085. It is programmable from 6 to 127.

The PFD compares  $f_{REF}/\text{RefDivRate}$  to  $f_{DAC}/(2 \times \text{BCount})$  and pulses the charge pump up or down to control the frequency of

the VCO. A low noise VCO is tunable over an octave with an oscillation range of 6 GHz to 12 GHz.

The clock multiplication circuit operates such that the VCO outputs a frequency,  $f_{VCO}$ .

$$f_{VCO} = f_{DAC} \times LODivFactor \quad (3)$$

From Equation 2, the DAC sample clock frequency,  $f_{DAC}$ , equals

$$f_{DAC} = 2 \times BCount \times \frac{f_{REF}}{RefDivFactor} \quad (4)$$

The LODivFactor is chosen to keep  $f_{VCO}$  in the operating range between 6 GHz and 12 GHz. The valid values for LODivFactor are 4, 8, and 16. Each LODivFactor maps to a LO\_DIV\_MODE value. The LO\_DIV\_MODE (Register 0x08B, Bits[1:0]) is programmed as described in Table 71.

**Table 71. DAC VCO Divider Selection**

DAC Frequency Range (MHz)	Divide by Factor (LODivFactor)	LO_DIV_MODE, Register 0x08B, Bits[1:0]
>1500	4	1
750 to 1500	8	2
420 to 750	16	3

Table 72 lists some common frequency examples for the RefDivFactor, LODivFactor, and BCount values that are needed to configure the PLL properly.

**Table 72. Common Frequency Examples**

Freq. (MHz)	$f_{DAC}$ (MHz)	$f_{VCO}$ (MHz)	RefDiv-Factor	LODiv-Factor	BCount
368.64	1474.56	11796.48	8	8	16
184.32	1474.56	11796.48	4	8	16
307.2	1228.88	9831.04	8	8	16
122.88	983.04	7864.35	2	8	8
61.44	983.04	7864.35	1	8	8
491.52	1966.08	7864.35	8	4	16
245.76	1966.08	7864.35	4	4	16

### Temperature Tracking

When properly configured, the device automatically selects one of the 512 VCO bands. The PLL settings selected by the device ensure that the PLL remains locked over the full  $-40^{\circ}\text{C}$  to  $+85^{\circ}\text{C}$  operating temperature range of the device without further adjustment. The PLL remains locked over the full temperature range even if the temperature during initialization is at one of the temperature extremes.

To properly configure temperature tracking, See Figure 17 and Figure 18 and the  $f_{VCO}$  dependent SPI writes shown in Table 73.

**Table 73. DAC PLL VCO Control Lookup Table**

VCO Frequency Range (GHz)	Register 0x1B6 Setting	Register 0x1BB Setting	Register 0x1B5 Setting	Register 0x1C5 Setting
$f_{VCO} < 6.84$	0x49	0x1A	0xC7	0x08
$6.84 \leq f_{VCO} < 8.69$	0x49	0x12	0xC9	0x06
$8.69 \leq f_{VCO} < 10.54$	0x4D	0x04	0xC9	0x06
$f_{VCO} \geq 10.54$	0x4D	0x04	0xC9	0x06

### STARTING THE PLL

The programming sequence for the DAC PLL is as follows:

1. Use the equations in the Clock Multiplication Relationships section to find  $f_{VCO}$ ,  $f_{REF}$ , BCount, RefDivMode, and LODivMode.
2. Program the registers in Figure 17 and Figure 18
3. Program the value of LODivMode into Register 0x08B, Bits[1:0].
4. Program the value of BCount into Register 0x085, Bits[7:0].
5. Program the value of RefDivMode into Register 0x08C, Bits[2:0].
6. Based on the  $f_{VCO}$  found in Step 1, write the temperature tracking registers as shown in Table 73.
7. Enable the DAC PLL synthesizer by setting Register 0x083, Bit 4 to 1.

Register 0x084, Bit 5 notifies the user that the DAC PLL calibration is completed and is valid.

Register 0x084, Bit 1 notifies the user that the PLL has locked.

Register 0x084, Bit 7 and Register 0x084, Bit 6 notify the user that the DAC PLL has reached the upper or lower edge of its operating band, respectively. If either of these bits are high, recalibrate the DAC PLL by setting Register 0x083, Bit 7 to 0 and then 1.

### DAC PLL IRQ

The DAC PLL lock and lost signals are available as IRQ events. Use Register 0x01F, Bits[7:6] to enable these signals, and then use Register 0x023, Bits[7:6] to read back their statuses and reset the IRQ signals. See the Interrupt Request Operation section for more information.

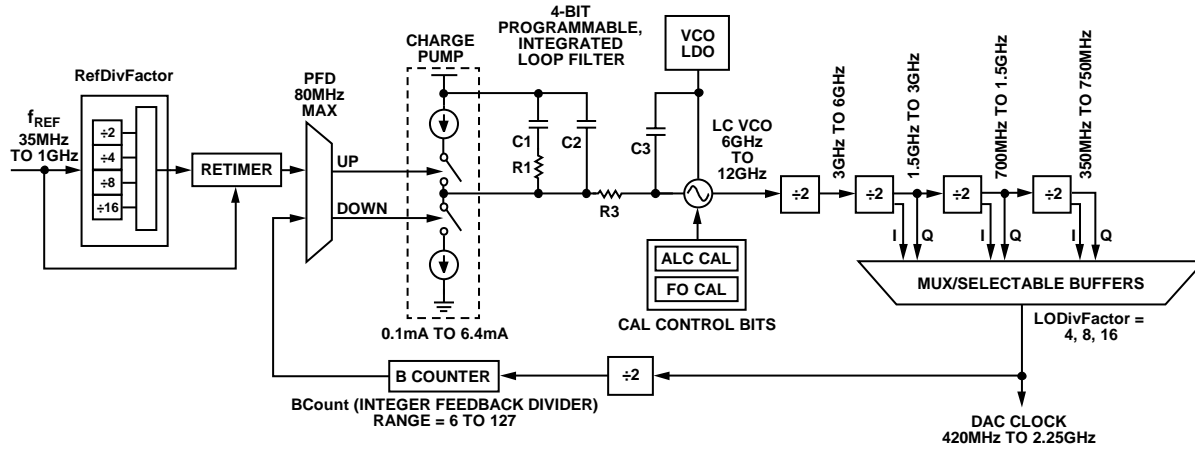

Figure 70. Device Clock PLL Block Diagram

12994-076

## ANALOG OUTPUTS

### TRANSMIT DAC OPERATION

Figure 71 shows a simplified block diagram of the transmit path DACs. The DAC core consists of a current source array, a switch core, digital control logic, and full-scale output current control. The DAC full-scale output current ( $I_{OUTFS}$ ) is nominally 20.22 mA. The output currents from the  $IOUT\pm/QOUT\pm$  pins are complementary, meaning that the sum of the two currents always equals the full-scale current of the DAC. The digital input code to the DAC determines the effective differential current delivered to the load.

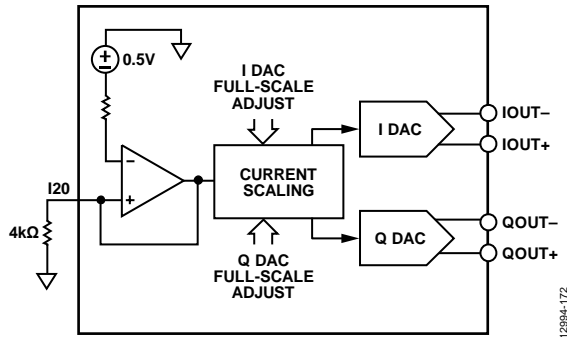

Figure 71. Simplified Block Diagram of the DAC Core

The DAC has a 0.5 V band gap reference with an output impedance of 5 kΩ. A 4 kΩ external resistor,  $R_{SET}$ , must be connected from the I120 pin to the ground plane. This resistor, along with the reference control amplifier, sets up the correct internal bias currents for the DAC. Because the full-scale current is inversely proportional to this resistor, the tolerance of  $R_{SET}$  is reflected in the full-scale output amplitude.

The full-scale current equation, where the DAC gain is set individually for the I and Q DACs in Register 0x040 through Register 0x043, respectively, is as follows:

$$I_{FS} = \frac{V_{REF}}{R_{SET}} \times \left( 13.33 + \left( \frac{1}{19.19} \times DAC \text{ gain} \right) \right)$$

For nominal values of  $V_{REF}$  (1.2 V),  $R_{SET}$  (4 kΩ), and DAC gain (1023), the full-scale current of the DAC is typically 20 mA. The DAC full-scale current can be adjusted from 4 mA to 20 mA by programming the values in Register 0x040 through Register 0x043, as shown in Table 74 and Figure 72.

Table 74. DAC Full-Scale Current Registers

Address	Value	Description
0x040[1:0]	DACFSC_I[9:8]	I DAC MSB gain code
0x041[7:0]	DACFSC_I[7:0]	I DAC LSB gain code
0x042[1:0]	DACFSC_Q[9:8]	Q DAC MSB gain code
0x043[7:0]	DACFSC_Q[7:0]	Q DAC LSB gain code

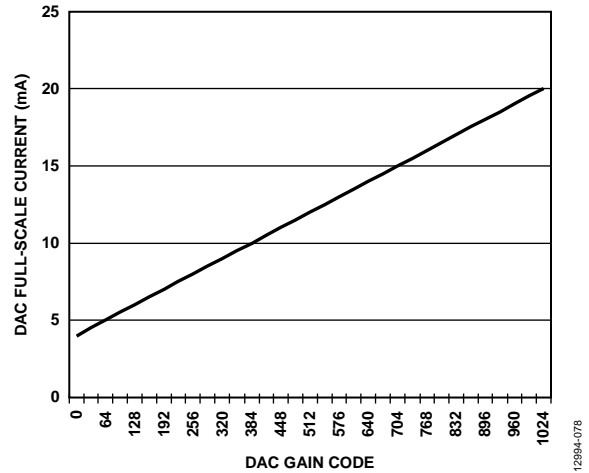

Figure 72. DAC Full-Scale Current vs. DAC Gain Code

### Transmit DAC Transfer Function

The output currents from the  $IOUT+/QOUT+$  and  $IOUT-/QOUT-$  pins are complementary, meaning that the sum of the positive and negative currents always equals the full-scale current of the DAC. The digital input code to the DAC determines the effective differential current delivered to the load.  $IOUT\pm$  and  $QOUT\pm$  provide the maximum output current when all bits are high for binary data. The output currents vs.  $DACCODE$  for the DAC outputs using binary format are expressed as

$$I_{OUTP} = \frac{DACCODE_{BIN}}{2^N} \times I_{OUTFS} \quad (5)$$

$$I_{OUTN} = I_{OUTFS} - I_{OUTP} \quad (6)$$

where  $DACCODE_{BIN}$  is the 16-bit input to the DAC in unsigned binary.  $DACCODE_{BIN}$  has a range of 0 to  $2^N - 1$ .

If the data format is twos complement, the output currents are expressed as

$$I_{OUTP} = \frac{DACCODE_{TWS} + 2^{N-1}}{2^N} \times I_{OUTFS} \quad (7)$$

$$I_{OUTN} = I_{OUTFS} - I_{OUTP}$$

## TEMPERATURE SENSOR

The AD9152 has a band gap temperature sensor for monitoring the temperature changes of the AD9152. The temperature must be calibrated against a known temperature to remove the device to device variation on the band gap circuit used to sense the temperature.

To monitor temperature change, take a reading at a known ambient temperature for a single-point calibration of each AD9152 device.

$$T_x = T_{REF} + 7.16 \times (CODE_x - CODE_{REF})/1000$$

where:

$CODE_x$  is the readback code at the unknown temperature,  $T_x$ .

$CODE_{REF}$  is the readback code at the known calibrated temperature,  $T_{REF}$ .

To use the temperature sensor, it must be enabled by setting Register 0x12F, Bit 0 to 1. The user must write 0 and then 1 to Register 0x134, Bit 0 before reading back the die temperature from Register 0x132 and Register 0x133.

## EXAMPLE START-UP SEQUENCE

Table 75 through Table 83 show the register writes needed to set up the AD9152 with  $f_{DAC} = 1474.56$  MHz,  $2\times$  interpolation, and the DAC PLL enabled with a 368.64 MHz reference clock. The JESD204B interface is configured in Mode 4, single link mode, Subclass 1, and scrambling is enabled with all four SERDES lanes running at 7.3728 Gbps, inputting twos complement formatted data. No remapping of lanes with the crossbar is used in this example.

The sequence of steps to properly start up the AD9152 are as follows:

1. Set up the SPI interface, power up necessary circuit blocks, make required writes to the configuration register, and set up the DAC clocks (see Step 1: Start Up the DAC).

Set the digital features of the AD9152 (see <sup>1</sup> 0x denotes a register value that the user must fill in. See the Variable and Description columns for information on selecting the appropriate register value.

2. Step 2: Digital Datapath).
3. Set up the JESD204B links (see Step 3: Transport Layer).
4. Set up the physical layer of the SERDES interface (see Step 4: Physical Layer).
5. Set up the data link layer of the SERDES interface. This procedure is for quick startup or debug only and does not guarantee deterministic latency (see Step 5: Data Link Layer).
6. Check for errors on the link (see Step 6: Optional Error Monitoring).

These steps are outlined in detail in the following sections in tables that list the required register write and read commands.

### STEP 1: START UP THE DAC

#### Power-Up and DAC Initialization

Table 75. Power-Up and DAC Initialization

Command	Addr.	Value	Description
W	0x000	0xBD	Soft reset
W	0x000	0x3C	Deassert reset, set 4-wire SPI
W	0x011	0x00	Enable the reference, DAC channels, and clocks
W	0x080	0x04	Enable duty cycle correction
W	0x081	0x04	Power up the SYSREF± receiver, disable hysteresis
W	0x1CD	0xD8	Band gap configuration

#### Required Device Configurations

Table 76. Required SERDES PLL Configuration

Command	Addr.	Value <sup>1</sup>	Description
W	0x284	0x62	SERDES PLL configuration
W	0x285	0xC9	SERDES PLL configuration
W	0x286	0xE	SERDES PLL configuration
W	0x287	0x12	SERDES PLL configuration
W	0x28A	0x	See Table 36
W	0x28B	0x0	SERDES PLL configuration
W	0x290	0x89	SERDES PLL configuration
W	0x291	0x	See Table 36
W	0x294	0x24	SERDES PLL configuration
W	0x296	0x	See Table 36
W	0x297	0xD	SERDES PLL configuration
W	0x299	0x2	SERDES PLL configuration
W	0x29A	0x8E	SERDES PLL configuration
W	0x29C	0x2A	SERDES PLL configuration
W	0x29F	0x7E	SERDES PLL configuration
W	0x2A0	0x6	SERDES PLL configuration

<sup>1</sup> 0x denotes a register value that the user must fill in. See the Variable and Description columns for information on selecting the appropriate register value.

#### Configure the DAC PLL

Table 77. Required DAC PLL Configuration

Command	Addr.	Value	Description
W	0x08D	0x7B	DAC PLL configuration
W	0x1B0	0x0	DAC PLL configuration
W	0x1B9	0x24	DAC PLL configuration
W	0x1BC	0xD	DAC PLL configuration
W	0x1BE	0x2	DAC PLL configuration
W	0x1BF	0x8E	DAC PLL configuration
W	0x1C0	0x2A	DAC PLL configuration
W	0x1C4	0x7E	DAC PLL configuration
W	0x1C1	0x2C	DAC PLL configuration

Table 78. Configure the DAC PLL

Command	Addr.	Value	Description
W	0x08B	0x02	Set the VCO LO divider to 8 such that $6 \text{ GHz} \leq f_{\text{VCO}} = f_{\text{DAC}} \times 2^{(\text{LODIVMode}+1)} \leq 12 \text{ GHz}$ .
W	0x08C	0x03	Set the reference clock divider to 8 so that the reference clock into the PLL is less than 80 MHz.
W	0x085	0x10	Set the B counter to 16 to divide the DAC clock down to 2x the reference clock.
W	0x1B6	0x	See Table 73
W	0x1B5	0x	See Table 73
W	0x1BB	0x	See Table 73
W	0x1B4	0x78	Optimal DAC PLL VCO settings.
W	0x1C5	0x	See Table 73
W	0x08A	0x12	Optimal DAC PLL VCO settings.
W	0x087	0x62	Optimal DAC PLL loop filter settings.
W	0x088	0xC9	Optimal DAC PLL loop filter settings.
W	0x089	0x0E	Optimal DAC PLL loop filter settings.
W	0x083	0x10	Enable the DAC PLL.
R	0x084	0x01	Verify that Bit 1 reads back high for PLL locked.

<sup>1</sup> 0x denotes a register value that the user must fill in. See the Variable and Description columns for information on selecting the appropriate register value.

## STEP 2: DIGITAL DATAPATH

Table 79. Digital Datapath

Command	Addr.	Value	Description
W	0x112	0x01	Set the interpolation to 2x.
W	0x110	0x00	Set twos complement data format.

## STEP 3: TRANSPORT LAYER

Table 80. Link Transport Layer

Command	Addr.	Value	Description
W	0x200	0x00	Power up the interface
W	0x201	0x00	Enable all lanes
W	0x300	0x00	First power down JESD204B digital (by default)
W	0x450	0x00	Set the device ID to match Tx (0x00 in this example)
W	0x451	0x00	Set the bank ID to match Tx (0x00 in this example)
W	0x452	0x00	Set the lane ID to match Tx (0x00 in this example)
W	0x453	0x83	Set descrambling and $L = 4$ (in $n - 1$ notation)
W	0x454	0x00	Set $F = 1$ (in $n - 1$ notation)
W	0x455	0x1F	Set $K = 32$ (in $n - 1$ notation)
W	0x456	0x01	Set $M = 2$ (in $n - 1$ notation)
W	0x457	0x0F	Set $N = 16$ (in $n - 1$ notation)
W	0x458	0x2F	Set Subclass 1 and $NP = 16$ (in $n - 1$ notation)
W	0x459	0x20	Set JESD204B Version and $S = 1$ (in $n - 1$ notation)
W	0x45A	0x80	Set $HD = 1$
W	0x45D	0x45	Set checksum for Lane 0
W	0x46C	0x0F	Deskew Lane 0 to Lane 3
W	0x476	0x01	Set $F$ (not in $n - 1$ notation)
W	0x47D	0x0F	Enable Lane 0 to Lane 3

## STEP 4: PHYSICAL LAYER

Table 81. Physical Layer

Command	Addr.	Value	Description
W	0x2A7	0x01	Autotune PHY setting
W	0x314	0x01	SERDES SPI configuration
W	0x230	0x29	Configure CDRs in half rate mode and set the $\text{SYNCOUT}_{\pm}$ swing VOD to 350 mV
W	0x206	0x00	Resets CDR logic
W	0x206	0x01	Release CDR logic reset
W	0x289	0x04	Configure the PLL divider to 1 along with PLL required configuration
W	0x280	0x01	Enable the SERDES PLL
R	0x281	0x01	Verify that Bit 0 reads back high for the SERDES PLL lock

## STEP 5: DATA LINK LAYER

Note that this procedure does not guarantee deterministic latency.

Table 82. Data Link Layer—Does Not Guarantee Deterministic Latency

Command	Addr.	Value	Description
W	0x301	0x01	Set the subclass = 1
W	0x304	0x00	Set the LMFC delay setting to 0
W	0x306	0x0A	Set the LMFC receive buffer delay to 10
W	0x03A	0x01	Set sync mode = one shot sync
W	0x03A	0x81	Enable the sync machine
W	0x03A	0xC1	Arm the sync machine
SYSREF $\pm$			Ensure that at least one SYSREF $\pm$ edge is sent to the device
W	0x300	0x01	Bit 0 = 1 to enable Link 0.

## STEP 6: OPTIONAL ERROR MONITORING

### Link Checks

Confirm that the registers in Table 83 read back as noted and system tasks are completed as described.

Table 83. Link Checks

Command	Addr.	Value	Description
R	0x470	0x0F	Acknowledge that four consecutive K28.5 characters have been detected on Lane 0 to Lane 3. Confirm that $\text{SYNCOUT}_{\pm}$ is high.
SERDIN $x_{\pm}$			Apply ILAS and data to SERDES input pins.
R	0x471	0x0F	Check for frame sync on all lanes.
R	0x472	0x0F	Check for good checksum.
R	0x473	0x0F	Check for ILAS.

## BOARD LEVEL HARDWARE CONSIDERATIONS

### POWER SUPPLY RECOMMENDATIONS

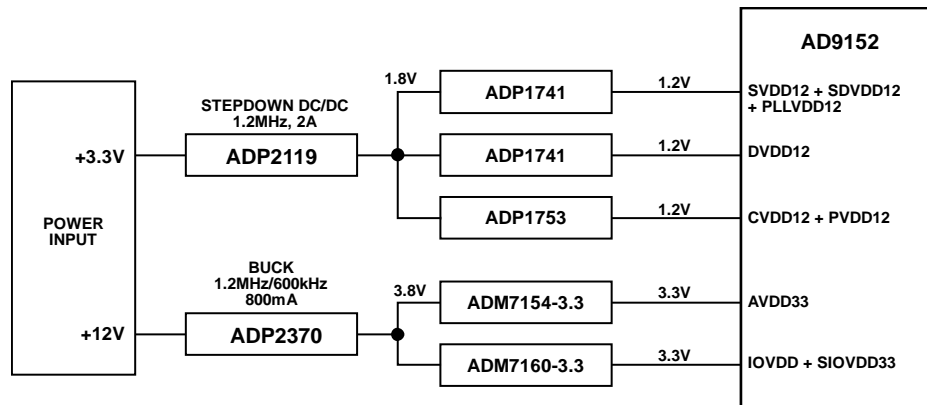

Figure 73. Power Supply Connections

Table 84. Power Supplies

Power Supply Domain	Voltage (V)	Circuitry
DVDD12 <sup>1</sup>	1.2	Digital core
PVDD12 <sup>2</sup>	1.2	DAC PLL
CVDD12 <sup>1</sup>	1.2	DAC clocking
SVDD12 <sup>3</sup>	1.2	JESD204B analog
SDVDD12 <sup>3</sup>	1.2	JESD204B digital
PLLVDD12 <sup>3</sup>	1.2	SERDES PLL
V <sub>TT</sub> <sup>4</sup>	1.2	V <sub>TT</sub>
AVDD33	3.3	DAC
IOVDD	3.3	SPI interface and IOs
SIOVDD33	3.3	Sync LVDS transmit

<sup>1</sup> This supply requires a 1.3 V supply when operating at maximum DAC sample rates. See Table 3 for details.

<sup>2</sup> This supply may be combined with CVDD12 on the same regulator with a separate supply filter network and sufficient bypass capacitors near the pins.

<sup>3</sup> This supply requires a 1.3 V supply when operating at maximum interface rates. See Table 4 for details.

<sup>4</sup> This supply is connected to SVDD12 and does not need separate circuitry.

The power supply domains are described in Table 84. The power supplies can be grouped into separate PCB domains as show in Figure 73. All the AD9152 supply domains must remain as noise free as possible. Optimal DAC output NSD and DAC output phase noise performance can be achieved using linear regulators that provide excellent power supply rejection. AVDD33, PVDD12, and CVDD12 are particularly sensitive to supply noise.

#### JESD204B SERIAL INTERFACE INPUTS (SERDINO± TO SERDIN3±)

When considering the layout of the JESD204B serial interface transmission lines, there are many factors to consider to maintain optimal link performance. Among these factors are insertion loss, return loss, signal skew, and the topology of the differential traces.

#### Insertion Loss

The JESD204B specification limits the amount of insertion loss allowed in the transmission channel (see Figure 41). The AD9152 equalization circuitry allows significantly more loss in the channel than is required by the JESD204B specification. It is still important that the designer of the PCB minimize the amount of insertion loss by adhering to the following guidelines:

- Keep the differential traces short by placing the AD9152 as near to the transmitting logic device as possible and routing the trace as directly as possible between the devices.
- Route the differential pairs on a single plane using a solid ground plane as a reference.
- Use a PCB material with a low dielectric constant (<4) to minimize loss, if possible.

When choosing between stripline and microstrip techniques, consider the following: stripline has less loss (see Figure 42) and emits less EMI, but requires the use of vias that can add complexity to the task of controlling the impedance, whereas microstrip (see Figure 43) is easier to implement if the component placement and density allow routing on the top layer and eases the task of controlling the impedance.

If using the top layer of the PCB is problematic or the advantages of stripline are desirable, follow these recommendations:

- Minimize the number of vias.
- If possible, use blind vias to eliminate via stub effects and use micro vias to minimize via inductance.
- If using standard vias, use the maximum via length to minimize the stub size. For example, on an 8-layer board, use Layer 7 for the stripline pair (see Figure 74).
- For each via pair, place a pair of ground vias adjacent to them to minimize the impedance discontinuity (see Figure 74).

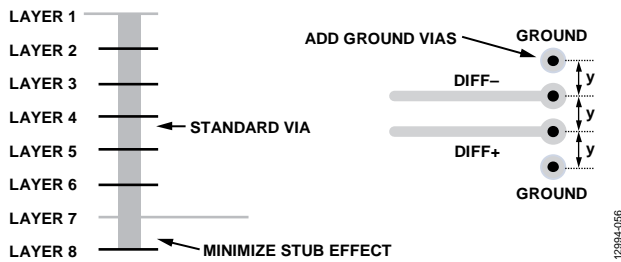

Figure 74. Minimizing Stub Effect and Adding Ground Vias for Differential Stripline Traces

**Return Loss**

The JESD204B specification limits the amount of return loss allowed in a converter device and a logic device, but does not specify return loss for the channel. However, every effort must be made to maintain a continuous impedance on the transmission line between the transmitting logic device and the AD9152. As mentioned in the Insertion Loss section, minimizing the use of vias, or eliminating them all together, reduces one of the primary sources for impedance mismatches on a transmission line. Maintain a solid reference beneath (for microstrip) or above and below (for stripline) the differential traces to ensure continuity in the impedance of the transmission line. If the stripline technique is used, follow the guidelines listed in the Insertion Loss section to minimize impedance mismatches and stub effects.

Another primary source for impedance mismatch is at either end of the transmission line, where care must be taken to match the impedance of the termination to that of the transmission line. The AD9152 handles this internally with a calibrated termination scheme for the receiving end of the line. See the Interface Power-Up and Input Termination section for details on this circuit and the calibration routine.

**Signal Skew**

There are many sources for signal skew, but the two sources to consider when laying out a PCB are interconnect skew within a

single JESD204B link and skew between multiple JESD204B links. In each case, keeping the channel lengths matched to within 15 mm is adequate for operating the JESD204B link at speeds of up to 12.38 Gbps. Managing the interconnect skew within a single link is fairly straightforward. Managing multiple links across multiple devices is more complex. However, follow the 15 mm guideline for length matching.

**Topology**

Structure the differential SERDINx± pairs to achieve 50 Ω to ground for each half of the pair. Stripline vs. microstrip trade-offs are described in the Insertion Loss section. In either case, it is important to keep these transmission lines separated from potential noise sources such as high speed digital signals and noisy supplies. If using stripline differential traces, route them using a coplanar method, with both traces on the same layer. Although this does not offer more noise immunity than the broadside routing method (traces routed on adjacent layers), it is easier to route and manufacture so that the impedance continuity is maintained. An illustration of the broadside technique vs. the coplanar technique is shown in Figure 75.

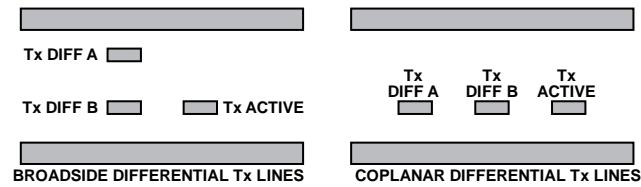

Figure 75. Broadside vs. Coplanar Differential Stripline Routing Techniques

When considering the trace width vs. copper weight and thickness, the speed of the interface must be considered. At multigigabit speeds, the skin effect of the conducting material confines the current flow to the surface. Maximize the surface area of the conductor by making the trace width wider to reduce the losses. Additionally, loosely couple differential traces to accommodate the wider trace widths. This helps reduce the crosstalk and minimize the impedance mismatch when the traces must separate to accommodate components, vias, connectors, or other routing obstacles. Tightly coupled vs. loosely coupled differential traces are shown in Figure 76.

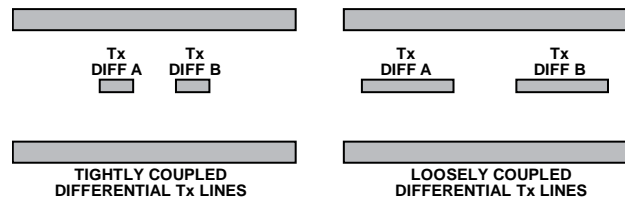

Figure 76. Tightly Coupled vs. Loosely Coupled Differential Traces

**AC Coupling Capacitors**

The AD9152 requires that the JESD204B input signals be ac-coupled to the source. These capacitors must be 100 nF and placed as close as possible to the transmitting logic device. To minimize the impedance mismatch at the pads, select the

package size of the capacitor so that the pad size on the PCB matches the trace width as closely as possible.

**SYNCOUT±, SYSREF±, and DACCLK±/REFCLK± Signals**

The SYNCOUT± and SYSREF± signals on the AD9152 are low speed LVDS differential signals. Use controlled impedance traces routed with 100 Ω differential impedance and 50 Ω to ground when routing these signals. As with the SERDIN0± to SERDIN3± data pairs, it is important to keep these signals separated from potential noise sources such as high speed digital signals and noisy supplies.

Separate the SYNCOUT± signal from other noisy signals, because noise on the SYNCOUT± might be interpreted as a request for K characters.

It is important to keep similar trace lengths for the DACCLK±/REFCLK± and SYSREF± signals from the clock source to each of the devices on either end of the JESD204B links, see Figure 77. If using a clock chip that can tightly control the phase of DACCLK±/REFCLK± and SYSREF±, the trace length matching requirements are greatly reduced.

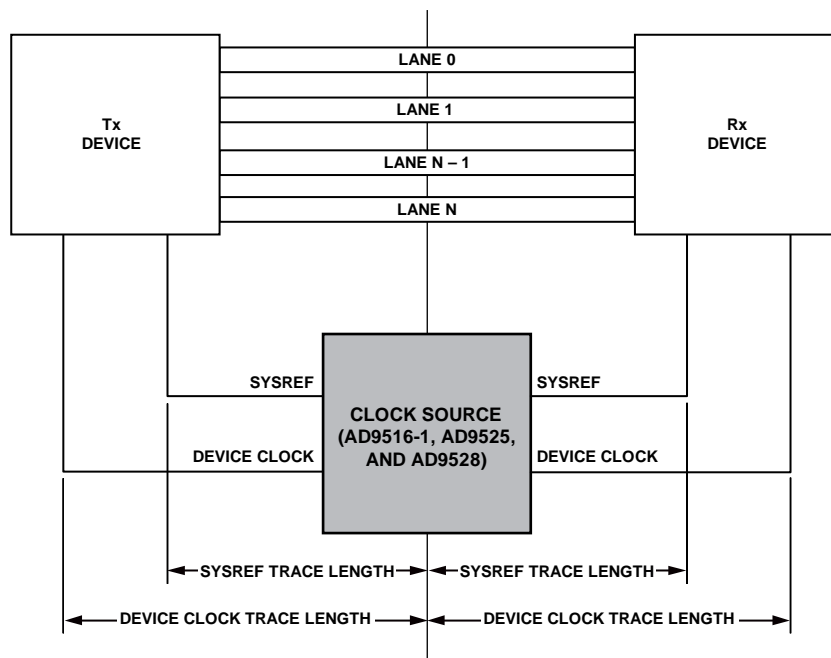

Figure 77. SYSREF± Signal and Device Clock Trace Length

12994-059

## REGISTER MAP AND DESCRIPTIONS

In the following tables, register addresses (Reg. column) and reset values (Reset column) are hexadecimal. In the read/write (R/W) column, R means read only, W means write only, R/W means read/write, and N/A means not applicable.

### DEVICE CONFIGURATION REGISTER MAP

Table 85. Device Configuration Register Map

Reg.	Name	Bit 7	Bit 6	Bit 5	Bit 4	Bit 3	Bit 2	Bit 1	Bit 0	Reset	RW	
0x000	SPI_INTFCONFA	SOFTRESET_M	LSBFIRST_M	ADDRINC_M	SDOACTIVE_M	SDOACTIVE	ADDRINC	LSBFIRST	SOFTRESET	0x00	R/W	
0x003	CHIPTYPE	CHIPTYPE								0x04	R	
0x004	PRODIDL	PRODIDL								0x52	R	
0x005	PRODIDH	PRODIDH								0x91	R	
0x006	CHIPGRADE	RESERVED				DEV_REVISION				0x08	R	
0x011	PWRCNTRL0	PD_BG	PD_DACI	PD_DACQ	PD_DIGCLK	PD_ICLK	PD_QCLK	PD_PCLK	PD_CLKRCVR	0x6C	R/W	
0x012	TXENMASK	RESERVED	DACA_MASK	RESERVED	CLKA_MASK	RESERVED				0x00	R/W	
0x013	PWRCNTRL3	RESERVED	PDP_PROTECT_OUT	TX_PROTECT_OUT	BSM_PROTECT_OUT	SPI_PROTECT_OUT_EN	SPI_PROTECT_OUT_CTRL	SPI_TXEN_EN	SPI_TXEN_CTRL	0x20	R/W	
0x014	PWRCNTRL1	RESERVED		POWER_DN_I	POWER_DN_Q	RESERVED		POWER_UP_I	POWER_UP_Q	0x00	R	
0x01F	IRQ_ENABLE0	IRQEN_DAC_PLLLOST	IRQEN_DAC_PLLLOCK	RESERVED	IRQEN_SERPLLLOST	IRQEN_SERPLLLOCK	RESERVED	IRQEN_LANE_FIFOERR	IRQEN_DRDL_FIFOERR	0x00	R/W	
0x020	IRQ_ENABLE1	IRQEN_PARMBAD	IRQEN_LANE_FIFO	IRQEN_DLYBUF	IRQEN_DATAREADY	IRQEN_OVERFLOW	RESERVED	IRQEN_PRBSQ	IRQEN_PRBSI	0x00	R/W	
0x021	IRQ_ENABLE2	IRQEN_PDPERR	RESERVED		IRQEN_NCOALIGN	IRQEN_SYNCLOCK	IRQEN_SYNCROTATE	IRQEN_SYNCWLIM	IRQEN_SYNCTRIP	0x00	R/W	
0x023	IRQ_STATUS0	DACPLLLOST	DACPLLLOCK	RESERVED	SERPLLLOST	SERPLLLOCK	RESERVED	LANEFIFOERR	DRDL_FIFOERR	0x00	R	
0x024	IRQ_STATUS1	PARMBAD	LANEFIFO	DLYBUF	DATAREADY	OVERFLOW	RESERVED	PRBSQ	PRBSI	0x00	R	
0x025	IRQ_STATUS2	PAERR	RESERVED	RESERVED	NCOALIGN	SYNCLOCK	SYNCROTATE	SYNCWLIM	SYNCTRIP	0x00	R	
0x026	OVERFLOW_STATUS0	PFIR_OVERFLOW	INT1_OVERFLOW	INT2_OVERFLOW	INT3_OVERFLOW	COARSE_MOD_BY8_OVERFLOW	FINE_MOD_OVERFLOW	PHASE_ADJ_OVERFLOW	GAIN_ADJ_OVERFLOW	0x00	R	
0x027	OVERFLOW_STATUS1	RESERVED							DC_OFFSET_OVERFLOW	0x00	R	
0x030	JESD_CHECKS	RESERVED		ERR_DLYOVER	ERR_WINLIMIT	ERR_JESDBAD	ERR_KUNSUPP	ERR_SUBCLASS	ERR_INTSUPP	0x00	R	
0x032	SYNC_DACDELAY_L	DAC_DELAY_L								0x00	R/W	
0x033	SYNC_DACDELAY_H	RESERVED								DAC_DELAY_H	0x00	R/W
0x034	SYNC_ERRWINDOW	RESERVED					ERRWINDOW				0x00	R/W
0x035	SYNC_DLYCOUNT	DLYCOUNT								0x00	R/W	
0x036	SYNC_REFCOUNT	REFCOUNT								0x00	R/W	
0x038	SYNC_LASTERR_L	LASTERROR_L								0x00	R	
0x039	SYNC_LASTERR_H	LASTUNDER	LASTOVER	RESERVED					LASTERROR_H	0x00	R	
0x03A	SYNC_CONTROL	SYNCENABLE	SYNCARM	SYNCCLRSTKY	SYNCCLRLAST	SYNCMODE				0x00	R/W	
0x03B	SYNC_STATUS	SYNCBUSY	RESERVED			SYNCLOCK	SYNCROTATE	SYNCWLIM	SYNCTRIP	0x00	R	
0x03C	SYNC_CURRERR_L	CURRERROR_L								0x00	R	
0x03D	SYNC_CURRERR_H	CURRUNDER	CURROVER	RESERVED					CURRERROR_H	0x00	R	
0x03E	ERROR_THERM	THRMOLD	RESERVED		THRMOVER	THRMPOS	THRMZERO	THRMNEG	THRMUNDER	0x00	R	
0x040	DAC_GAIN1_I	RESERVED						DACFSC_I[9:8]		0x03	R/W	
0x041	DAC_GAIN0_I	DACFSC_I[7:0]								0xFF	R/W	
0x042	DAC_GAIN1_Q	RESERVED						DACFSC_Q[9:8]		0x03	R/W	
0x043	DAC_GAIN0_Q	DACFSC_Q[7:0]								0xFF	R/W	
0x047	COARSE_GROUP_DLY	COARSE_GROUP_DLY_I				COARSE_GROUP_DLY_Q				0x88	R/W	
0x050	NCOALIGN_MODE	NCO_ALIGN_ARM	RESERVED	NCO_ALIGN_MTCH	NCO_ALIGN_PASS	NCO_ALIGN_FAIL	RESERVED	NCO_ALIGN_MODE		0x00	R/W	
0x051	NCOKEY_ILSB	NCOKEYI[7:0]								0x00	R/W	

Reg.	Name	Bit 7	Bit 6	Bit 5	Bit 4	Bit 3	Bit 2	Bit 1	Bit 0	Reset	RW		
0x052	NCOKEY_IMSB	NCOKEY[15:8]								0x00	R/W		
0x053	NCOKEY_QLSB	NCOKEYQ[7:0]								0x00	R/W		
0x054	NCOKEY_QMSB	NCOKEYQ[15:8]								0x00	R/W		
0x060	PDP_THRES0	PDP_THRESHOLD[7:0]								0x00	R/W		
0x061	PDP_THRES1	RESERVED				PDP_THRESHOLD[12:8]				0x00	R/W		
0x062	PDP_AVG_TIME	PDP_ENABLE	RESERVED				PDP_AVG_TIME				0x00	R/W	
0x063	PDP_POWER0	PDP_POWER[7:0]								0x00	R		
0x064	PDP_POWER1	RESERVED				PDP_POWER[12:8]				0x00	R		
0x065	PA_OFFGAIN0	EN_UKIRQ-OFFGAIN	RESERVED					EN_DELAYBUFF-EROFFGAIN	EN_LANEFIFO-OFFGAIN	0x00	R/W		
0x066	PA_OFFGAIN1	EN_CMMIRQ-OFFGAIN	EN_CGSIRQ-GAIN	EN_FSIRQOFF-GAIN	EN_GCSIRQ-OFFGAIN	EN_ILSIRQ-OFFGAIN	EN_ILDIRQOFF-GAIN	EN_DISIRQOFF-GAIN	EN_NITIRQOFF-GAIN	0x00	R/W		
0x080	CLKCFG0	RESERVED					DUTY_EN	RESERVED				0x04	R/W
0x081	SYSREF_ACTRL0	RESERVED				PD_SYSREF	HYS_ON	SYSREF_RISE	HYS_CNTRL1			0x10	R/W
0x082	SYSREF_ACTRL1	HYS_CNTRL0								0x00	R/W		
0x083	DACPLLCTRL	RECAL_DACPLL	RESERVED			ENABLE_DACPLL	RESERVED					0x00	R/W
0x084	DACPLLSTATUS	CP_OVER-RANGE_H	CP_OVER-RANGE_L	CP_CAL_VALID	VCO_CAL_PROGRESS	CURRENTS_READY	RESERVED	DAC_PLL_LOCK	RESERVED	0x00	R/W		
0x085	DACINTEGERWORD0	B_COUNT								0x06	R/W		
0x087	DACLOOPFLT1	LF_C2_WORD					LF_C1_WORD					0x88	R/W
0x088	DACLOOPFLT2	LF_R1_WORD					LF_C3_WORD					0x88	R/W
0x089	DACLOOPFLT3	LF_BYPASS_R3	LF_BYPASS_R1	LF_BYPASS_C2	LF_BYPASS_C1	LF_R3_WORD					0x08	R/W	
0x08A	DACCPCNTRL	RESERVED			CP_CURRENT					0x20	R/W		
0x08B	DACLOGENCNTRL	RESERVED							LO_DIV_MODE		0x00	R/W	
0x08C	DACLDOCNTRL1	RESERVED					REF_DIV_MODE					0x00	R/W
0x08E	CLK_DETECT	RESERVED				PD_DAC_ONDIFF	PD_DAC_ONDET	CLK_ON	IS_DIFF	CLK_DET_EN	0x00	R/W	
0x0F7	DIG_TEST0	RESERVED								DC_TEST_MOD	DIG_CLK_PD	0x1C	R/W
0x0F8	DC_TEST_VALUEI0	DC_TEST_VALUEI[7:0]								0x00	R/W		
0x0F9	DC_TEST_VALUEI1	DC_TEST_VALUEI[15:8]								0x00	R/W		
0x0FA	DC_TEST_VALUEEQ0	DC_TEST_VALUEEQ[7:0]								0x00	R/W		
0x0FB	DC_TEST_VALUEEQ1	DC_TEST_VALUEEQ[15:8]								0x00	R/W		
0x110	DATA_FORMAT	BINARY_FORMAT	RESERVED								0x00	R/W	
0x111	DATAPATH_CTRL	INVSINC_ENABLE	RESERVED	DIG_GAIN_ENABLE	PHASE_ADJ_ENABLE	MODULATION_TYPE		SEL_SIDE BAND	RESERVED	0x20	R/W		
0x112	INTERP_MODE	SINGLE_DAC_EN	RESERVED					INTERP_MODE			0x01	R/W	
0x113	NCO_FTW_UPDATE	RESERVED							FTW_UPDATE_ACK	FTW_UPDATE_REQ	0x00	R/W	
0x114	FTW0	FTW[7:0]								0x00	R/W		
0x115	FTW1	FTW[15:8]								0x00	R/W		
0x116	FTW2	FTW[23:16]								0x00	R/W		
0x117	FTW3	FTW[31:24]								0x00	R/W		
0x118	FTW4	FTW[39:32]								0x00	R/W		
0x119	FTW5	FTW[47:40]								0x10	R/W		
0x11A	NCO_PHASE_OFFSET0	NCO_PHASE_OFFSET[7:0]								0x00	R/W		
0x11B	NCO_PHASE_OFFSET1	NCO_PHASE_OFFSET[15:8]								0x00	R/W		
0x11C	IQ_PHASE_ADJ0	PHASE_ADJ[7:0]								0x00	R/W		
0x11D	IQ_PHASE_ADJ1	RESERVED				PHASE_ADJ[12:8]				0x00	R/W		

Reg.	Name	Bit 7	Bit 6	Bit 5	Bit 4	Bit 3	Bit 2	Bit 1	Bit 0	Reset	RW		
0x11F	TXEN_SM_0	FALL_COUNTERS		RISE_COUNTERS		RESERVED	PROTECT_OUT_I NVERT	RESERVED	TXEN_SM_EN	0x83	R/W		
0x125	DACOUT_ON_ DOWN	RESERVED						DACOUT_ SHUTDOWN	DACOUT_ON_ TRIGGER	0x00	R/W		
0x12C	DACOFF	PROTECT_ MODE	RESERVED								DACOFF_AVG_ PW	0x81	R/W
0x12F	DIE_TEMP_CTRL0	RESERVED	FS_CURRENT			RESERVED			TEMP_SENSOR_ ENABLE	0x20	R/W		
0x132	DIE_TEMP0	DIE_TEMP[7:0]								0x00	R		
0x133	DIE_TEMP1	DIE_TEMP[15:8]								0x00	R		
0x134	DIE_TEMP_UPDATE	RESERVED							DIE_TEMP_ UPDATE	0x00	R/W		
0x135	DC_OFFSET_CTRL	RESERVED							DC_OFFSET_ON	0x00	R/W		
0x136	IPATH_DC_OFFSET_ 1PART0	LSB_OFFSET_I[7:0]								0x00	R/W		
0x137	IPATH_DC_OFFSET_ 1PART1	LSB_OFFSET_I[15:8]								0x00	R/W		
0x138	QPATH_DC_ OFFSET_1PART0	LSB_OFFSET_Q[7:0]								0x00	R/W		
0x139	QPATH_DC_ OFFSET_1PART1	LSB_OFFSET_Q[15:8]								0x00	R/W		
0x13A	IPATH_DC_OFFSET_ 2PART	RESERVED			SIXTEENTH_OFFSET_I					0x00	R/W		
0x13B	QPATH_DC_ OFFSET_2PART	RESERVED			SIXTEENTH_OFFSET_Q					0x00	R/W		
0x13C	IDAC_DIG_GAIN0	IDAC_DIG_GAIN[7:0]								0x00	R/W		
0x13D	IDAC_DIG_GAIN1	RESERVED				IDAC_DIG_GAIN[11:8]				0x08	R/W		
0x13E	QDAC_DIG_GAIN0	QDAC_DIG_GAIN[7:0]								0x00	R/W		
0x13F	QDAC_DIG_GAIN1	RESERVED				QDAC_DIG_GAIN[11:8]				0x08	R/W		
0x140	GAIN_RAMP_UP_ STEP0	GAIN_RAMP_UP_STEP[7:0]								0x04	R/W		
0x141	GAIN_RAMP_UP_ STEP1	RESERVED				GAIN_RAMP_UP_STEP[11:8]				0x00	R/W		
0x142	GAIN_RAMP_ DOWN_STEP0	GAIN_RAMP_DOWN_STEP[7:0]								0x09	R/W		
0x143	GAIN_RAMP_ DOWN_STEP1	RESERVED				GAIN_RAMP_DOWN_STEP[7:0]				0x00	R/W		
0x14B	PRBS	PRBS_ GOOD_Q	PRBS_GOOD_I	RESERVED	PRBS_INV_Q	PRBS_INV_I	PRBS_MODE	PRBS_RESET	PRBS_EN	0x10	R/W		
0x14C	PRBS_ERROR_I	PRBS_COUNT_I								0x00	R		
0x14D	PRBS_ERROR_Q	PRBS_COUNT_Q								0x00	R		
0x151	DATAPATH_CTRL2	RESERVED		PFIR_DEMOD4_ ENABLE	PFIR_ENABLE	RESERVED		NEG_DDS_FREQ	MODULUS_ ENABLE	0x00	R/W		
0x152	ACC_MODULUS0	ACC_MODULUS[7:0]								0x00	R/W		
0x153	ACC_MODULUS1	ACC_MODULUS[15:8]								0x00	R/W		
0x154	ACC_MODULUS2	ACC_MODULUS[23:16]								0x00	R/W		
0x155	ACC_MODULUS3	ACC_MODULUS[31:24]								0x00	R/W		
0x156	ACC_MODULUS4	ACC_MODULUS[39:32]								0x00	R/W		
0x157	ACC_MODULUS5	ACC_MODULUS[47:40]								0x00	R/W		
0x158	ACC_DELTA0	ACC_DELTA[7:0]								0x00	R/W		
0x159	ACC_DELTA1	ACC_DELTA[15:8]								0x00	R/W		
0x15A	ACC_DELTA2	ACC_DELTA[23:16]								0x00	R/W		
0x15B	ACC_DELTA3	ACC_DELTA[31:24]								0x00	R/W		
0x15C	ACC_DELTA4	ACC_DELTA[39:32]								0x00	R/W		
0x15D	ACC_DELTA5	ACC_DELTA[47:40]								0x00	R/W		
0x17A	PFIR_COEFF0_L	PFIR_COEFF0[7:0]								0x00	R/W		
0x17B	PFIR_COEFF0_H	RESERVED							PFIR_COEFF0[8]	0x00	R/W		

Reg.	Name	Bit 7	Bit 6	Bit 5	Bit 4	Bit 3	Bit 2	Bit 1	Bit 0	Reset	RW	
0x17C	PFIR_COEFF1_L	PFIR_COEFF1[7:0]								0x00	R/W	
0x17D	PFIR_COEFF1_H	RESERVED							PFIR_COEFF1[8]	0x00	R/W	
0x17E	PFIR_COEFF2_L	PFIR_COEFF2[7:0]								0x00	R/W	
0x17F	PFIR_COEFF2_H	RESERVED							PFIR_COEFF2[8]	0x00	R/W	
0x180	PFIR_COEFF3_L	PFIR_COEFF3[7:0]								0x00	R/W	
0x181	PFIR_COEFF3_H	RESERVED							PFIR_COEFF3[8]	0x00	R/W	
0x182	PFIR_COEFF_UPDATE	RESERVED							PFIR_COEFF_UPDATE	0x00	R/W	
0x1B4	DACPLLT4	BYP_LOAD_DELAY	VCO_CAL_OFFSET				RESERVED	EXT_BAND_EN	EXT_BAND2	0x78	R/W	
0x1B5	DACPLLT5	INIT_ALC_VALUE				VCO_VAR				0x83	R/W	
0x1B6	DACPLLT6	RESERVED	PORESETB_VCO	EXT_VCO_BITSEL		VCO_LVL_OUT				0x4A	R/W	
0x1BB	DACPLLTB	RESERVED			VCO_BIAS_TCF		VCO_BIAS_REF			0x0C	R/W	
0x1C5	DACPLLT18	RESERVED				VCO_VAR_REF				0x08	R/W	
0x1FE	TEST_MODE	RESERVED					TSTWINDOW			0x00	R/W	
0x200	MASTER_PD	RESERVED							SPI_PD_MASTER	0x01	R/W	
0x201	PHY_PD	RESERVED				SPI_PD_PHY				0x00	R/W	
0x203	GENERIC_PD	RESERVED						SPI_SYNC_PD	RESERVED	0x00	R/W	
0x206	CDR_RESET	RESERVED							SPI_CDR_RESETN	0x01	R/W	
0x230	CDR_OPERATING_MODE_REG_0	RESERVED	ENHALFRATE	RESERVED			CDR_OVERSAMP	SYNCOU_TB_SWING	0x28	R/W		
0x268	EQ_BIAS_REG	EQ_POWER_MODE	RESERVED							0x62	R/W	
0x280	SERDESPLL_ENABLE_CNTRL	RESERVED					RECAL_SERDESPLL	RESERVED	ENABLE_SERDESPLL	0x00	R/W	
0x281	SERDES_PLL_STATUS	RESERVED	SERDES_CP_OVER_RANGE_H	SERDES_CP_OVER_RANGE_L	SERDES_PLL_CAL_VALID	SERDES_VCO_CAL_PROGRESS	SERDES_PLL_CURRENTS_READY	SERDES_PLL_LOCK	0x00	R		
0x289	REF_CLK_DIVIDER_LDO	RESERVED						SERDES_PLL_DIV_MODE	0x04	R/W		
0x2A7	TERM_BLK1_CTRLREG0	RESERVED							SPI_I_TUNE_R_CAL_TERMBLK1	0x00	R/W	
0x300	GENERAL_JRX_CTRL_0	RESERVED	CHECKSUM_MODE	RESERVED					LINK_EN	0x00	R/W	
0x301	GENERAL_JRX_CTRL_1	RESERVED					SUBCLASSV_LOCAL			0x01	R/W	
0x302	DYN_LINK_LATENCY_0	RESERVED			DYN_LINK_LATENCY_0					0x00	R/W	
0x304	LMFC_DELAY_0	RESERVED			LMFC_DELAY_0					0x00	R/W	
0x306	LMFC_VAR_0	RESERVED			LMFC_VAR_0					0x06	R/W	
0x308	XBAR_LN_0_1	RESERVED	LOGICAL_LANE1_SRC			LOGICAL_LANE0_SRC			0x08	R/W		
0x309	XBAR_LN_2_3	RESERVED	LOGICAL_LANE3_SRC			LOGICAL_LANE2_SRC			0x1A	R/W		
0x30C	FIFO_STATUS_REG_0	RESERVED				LANE_FIFO_FULL				0x00	R	
0x30D	FIFO_STATUS_REG_1	RESERVED				LANE_FIFO_EMPTY				0x00	R	
0x311	SYNCB_GEN_0	RESERVED			RESERVED	EOMF_MASK_0	RESERVED	EOF_MASK_0	0x00	R/W		
0x312	SYNCB_GEN_1	SYNCB_ERR_DUR			SYNCB_SYNCREQ_DUR					0x00	R/W	
0x313	SYNCB_GEN_3	LMFC_PERIOD									0x00	R
0x314	SERDES_SPI_REG	SERDES_SPI_CONFIG									0x00	R/W
0x315	PHY_PRBS_TEST_EN	RESERVED				PHY_TEST_EN				0x00	R/W	
0x316	PHY_PRBS_TEST_CTRL	RESERVED	PHY_SRC_ERR_CNT			PHY_PRBS_PAT_SEL		PHY_TEST_START	PHY_TEST_RESET	0x00	R/W	
0x317	PHY_PRBS_TEST_THRESHOLD_LOBITS	PHY_PRBS_THRESHOLD[7:0]								0x00	R/W	
0x318	PHY_PRBS_TEST_THRESHOLD_MIDBITS	PHY_PRBS_THRESHOLD[15:8]								0x00	R/W	

Reg.	Name	Bit 7	Bit 6	Bit 5	Bit 4	Bit 3	Bit 2	Bit 1	Bit 0	Reset	RW
0x319	PHY_PRBS_TEST_THRESHOLD_HIBITS	PHY_PRBS_THRESHOLD[23:16]								0x00	R/W
0x31A	PHY_PRBS_TEST_ERRCNT_LOBITS	PHY_PRBS_ERR_CNT[7:0]								0x00	R
0x31B	PHY_PRBS_TEST_ERRCNT_MIDBITS	PHY_PRBS_ERR_CNT[15:8]								0x00	R
0x31C	PHY_PRBS_TEST_ERRCNT_HIBITS	PHY_PRBS_ERR_CNT[23:16]								0x00	R
0x31D	PHY_PRBS_TEST_STATUS	RESERVED				PHY_PRBS_PASS				0x0F	R
0x32C	SHORT_TPL_TEST_0	RESERVED		SHORT_TPL_SP_SEL		SHORT_TPL_DAC_SEL		SHORT_TPL_TEST_RESET	SHORT_TPL_TEST_EN	0x00	R/W
0x32D	SHORT_TPL_TEST_1	SHORT_TPL_REF_SP_LSB								0x00	R/W
0x32E	SHORT_TPL_TEST_2	SHORT_TPL_REF_SP_MSB								0x00	R/W
0x32F	SHORT_TPL_TEST_3	RESERVED							SHORT_TPL_FAIL	0x00	R
0x334	JESD_BIT_INVERSE_CTRL	RESERVED				JESD_BIT_INVERSE				0x00	R/W
0x400	DID_REG	DID_RD								0x00	R
0x401	BID_REG	ADJCNT_RD				BID_RD				0x00	R
0x402	LID0_REG	RESERVED	ADJDIR_RD	PHADJ_RD	LID0_RD				0x00	R	
0x403	SCR_L_REG	SCR_RD	RESERVED			L-1_RD				0x00	R
0x404	F_REG	RESERVED				F-1_RD				0x00	R
0x405	K_REG	RESERVED				K-1_RD				0x00	R
0x406	M_REG	RESERVED				M-1_RD				0x00	R
0x407	CS_N_REG	CS_RD		RESERVED		N-1_RD				0x00	R
0x408	NP_REG	SUBCLASSV_RD				NP-1_RD				0x00	R
0x409	S_REG	JESDV_RD				S-1_RD				0x00	R
0x40A	HD_CF_REG	HD_RD	RESERVED			CF_RD				0x00	R
0x40B	RES1_REG	RES1_RD								0x00	R
0x40C	RES2_REG	RES2_RD								0x00	R
0x40D	CHECKSUM_REG	FCHK0_RD								0x00	R
0x40E	COMPSUM0_REG	FCMP0_RD								0x00	R
0x412	LID1_REG	RESERVED				LID1_RD				0x00	R
0x415	CHECKSUM1_REG	FCHK1_RD								0x00	R
0x416	COMPSUM1_REG	FCMP1_RD								0x00	R
0x41A	LID2_REG	RESERVED				LID2_RD				0x00	R
0x41D	CHECKSUM2_REG	FCHK2_RD								0x00	R
0x41E	COMPSUM2_REG	FCMP2_RD								0x00	R
0x422	LID3_REG	RESERVED				LID3_RD				0x00	R
0x425	CHECKSUM3_REG	FCHK3_RD								0x00	R
0x426	COMPSUM3_REG	FCMP3_RD								0x00	R
0x450	ILS_DID	DID								0x00	R/W
0x451	ILS_BID	ADJCNT				BID				0x00	R/W
0x452	ILS_LID0	RESERVED	ADJDIR	PHADJ	LID0				0x00	R/W	
0x453	ILS_SCR_L	SCR	RESERVED			L-1				0x83	R/W
0x454	ILS_F	RESERVED				F-1				0x00	R/W
0x455	ILS_K	RESERVED				K-1				0x1F	R/W
0x456	ILS_M	RESERVED				M-1				0x01	R/W
0x457	ILS_CS_N	CS		RESERVED		N-1				0x0F	R/W
0x458	ILS_NP	SUBCLASSV				NP-1				0x2F	R/W
0x459	ILS_S	JESDV				S-1				0x20	R/W
0x45A	ILS_HD_CF	HD	RESERVED			CF				0x80	R/W
0x45B	ILS_RES1	RES1								0x00	R/W

Reg.	Name	Bit 7	Bit 6	Bit 5	Bit 4	Bit 3	Bit 2	Bit 1	Bit 0	Reset	RW	
0x45C	ILS_RES2	RES2								0x00	R/W	
0x45D	ILS_CHECKSUM	FCHK0								0x45	R/W	
0x46B	ERRCNTRMON_RB	READERORCNR								0x00	R	
0x46B	ERRCNTRMON	RESERVED	LANESEL			RESERVED		CNTRSEL		0x00	W	
0x46C	LANEDESKEW	LANEDESKEW								0x0F	R/W	
0x46D	BADDISPARITY_RB	BADDIS								0x00	R	
0x46D	BADDISPARITY	RST_IRQ_DIS	DISABLE_ERR_CNTR_DIS	RST_ERR_CNTR_DIS	RESERVED		LANE_ADDR_DIS		0x00	W		
0x46E	NIT_RB	NIT								0x00	R	
0x46E	NIT_W	RST_IRQ_NIT	DISABLE_ERR_CNTR_NIT	RST_ERR_CNTR_NIT	RESERVED		LANE_ADDR_NIT		0x00	W		
0x46F	UNEXPECTED_CONTROL_RB	UCC								0x00	R	
0x46F	UNEXPECTED_CONTROL_W	RST_IRQ_UCC	DISABLE_ERR_CNTR_UCC	RST_ERR_CNTR_UCC	RESERVED		LANE_ADDR_UCC		0x00	W		
0x470	CODEGRPSYNCFLG	CODEGRPSYNC								0x00	R/W	
0x471	FRAMESYNCFLG	FRAMESYNC								0x00	R/W	
0x472	GOODCHKSUMFLG	GOODCHECKSUM								0x00	R/W	
0x473	INITLANESYNCFLG	INITIALLANESYNC								0x00	R/W	
0x476	CTRLREG1	F								0x01	R/W	
0x477	CTRLREG2	ILAS_MODE	RESERVED			THRESHOLD_MASK_EN	RESERVED				0x00	R/W
0x478	KVAL	KSYNC								0x01	R/W	
0x47A	IRQVECTOR_FLAG	BADDIS_FLAG	NIT_FLAG	UCC_FLAG	RESERVED	INITIALLANE_SYNC_FLAG	BADCHECKSUM_FLAG	FRAMESYNC_FLAG	CODEGRPSYNC_FLAG	0x00	R	
0x47A	IRQVECTOR_MASK	BADDIS_MASK	NIT_MASK	UCC_MASK	RESERVED	INITIALLANE_SYNC_MASK	BADCHECKSUM_MASK	FRAMESYNC_MASK	CODEGRPSYNC_MASK	0x00	W	
0x47B	SYNCASSERTION-MASK	BADDIS_S	NIT_S	UCC_S	CMM	CMM_ENABLE	RESERVED			0x08	R/W	
0x47C	ERRORTHRES	ETH								0xFF	R/W	
0x47D	LANEENABLE	RESERVED				LANE_ENA				0x0F	R/W	
0x47E	RAMP_ENA	RESERVED							ENA_RAMP_CHECK	0x00	R/W	

## DEVICE CONFIGURATION REGISTER DESCRIPTIONS

Table 86. Device Configuration Register Descriptions

Addr.	Name	Bits	Bit Name	Settings	Description	Reset	Access
0x000	SPI_INTFCONFA	7	SOFTRESET_M		Soft reset (mirror).	0x0	R
		6	LSBFIRST_M		LSB first (mirror).	0x0	R
		5	ADDRINC_M		Address increment (mirror).	0x0	R
		4	SDOACTIVE_M		SDO active (mirror).	0x0	R
		3	SDOACTIVE		SDO active.	0x0	R/W
		2	ADDRINC		Address increment. When set, causes incrementing streaming addresses; otherwise descending addresses are generated. 1 During streaming bytes mode (multibyte), the addresses are incremented. 0 During streaming bytes mode (multibyte), the addresses are decremented.	0x0	R/W
		1	LSBFIRST		LSB first. When set, causes input and output data to be oriented as LSB first. If this bit is clear, data is oriented as MSB first. 1 Shift LSB in first. 0 Shift MSB in first.	0x0	R/W
		0	SOFTRESET		Soft reset. Setting this bit initiates a reset. This bit is auto-clearing after the soft reset is complete. 1 Assert soft reset.	0x0	R/W
0x003	CHIPTYPE	[7:0]	CHIPTYPE		The product type is high speed DAC, which is	0x4	R

Addr.	Name	Bits	Bit Name	Settings	Description	Reset	Access
					represented by a code of 0x04.		
0x004	PRODIDL	[7:0]	PRODIDL		Product ID low.	0x52	R
0x005	PRODIDH	[7:0]	PRODIDH		Product ID high.	0x91	R
0x006	CHIPGRADE	[7:5]	RESERVED		Reserved.	0x0	R
		[4:0]	DEV_REVISION		Device revision.	0x8	R
0x011	PWRCNTRL0	7	PD_BG	0 1	Reference power-down. Powers down the band gap reference for the entire chip. Circuits are not provided with bias currents. Reference on. Reference powered down (overrides TXEN masked bit).	0x0	R/W
		6	PD_DAC_I	1	Power down DAC bias for I DAC. Power down I DAC.	0x1	R/W
		5	PD_DAC_Q	1	Power down DAC bias for Q DAC. Power down Q DAC.	0x1	R/W
		4	PD_DIGCLK		Power down digital clock.	0x0	R/W
		3	PD_ICLK		Power down DAC clock For I DAC.	0x1	R/W
		2	PD_QCLK		Power down DAC clock For Q DAC.	0x1	R/W
		1	PD_PCLK		Power down PCLK.	0x0	R/W
		0	PD_CLKRCVR		Power down clock receiver.	0x0	R/W
0x012	TXENMASK	7	RESERVED		Reserved.	0x0	R/W
		6	DACA_MASK	1	DAC power-down mask for TXEN. If TXEN is low, DAC I and DAC Q are powered down.	0x0	R/W
		5	RESERVED		Reserved.	0x0	R/W
		4	CLKA_MASK	1	DAC clock power-down mask from TXEN. If TXEN is low digital clocks are powered down.	0x0	R/W
		[3:0]	RESERVED		Reserved.	0x0	R/W
0x013	PWRCNTRL3	7	RESERVED		Reserved.	0x0	R/W
		6	PDP_PROTECT_OUT	1	PDP_PROTECT triggers PROTECT_OUT.	0x0	R/W
		5	TX_PROTECT_OUT	1	TX_PROTECT triggers PROTECT_OUT.	0x1	R/W
		4	BSM_PROTECT_OUT	1	BSM_PROTEXT triggers PROTECT_OUT.	0x0	R/W
		3	SPI_PROTECT_OUT_EN	1	SPI_PROTECT triggers PROTECT_OUT.	0x0	R/W
		2	SPI_PROTECT_OUT_CTRL	1	PROTECT_OUT is low.	0x0	R/W
		1	SPI_TXEN_EN	1	TXEN is controlled by SPI.	0x0	R/W
		0	SPI_TXEN_CTRL	1	TXEN SPI is high.	0x0	R/W
0x014	PWRCNTRL1	[7:6]	RESERVED		Reserved.	0x0	R
		5	POWER_DN_I	1	I DAC power-down status. DAC is fully powered down.	0x0	R
		4	POWER_DN_Q	1	Q DAC power-down status. DAC is fully powered down.	0x0	R
		[3:2]	RESERVED		Reserved.	0x0	R
		1	POWER_UP_I	1	I DAC power-up status. DAC is fully powered up.	0x0	R
		0	POWER_UP_Q	1	Q DAC power-up status. DAC is fully powered up.	0x0	R
0x01F	IRQ_ENABLE0	7	IRQEN_DACPLLLIST	1 0	Enable the IRQ of DAC PLL lost detection. If IRQEN_DACPLLLIST goes high, it latches and pulls IRQ low. IRQEN_DACPLLLIST shows current status.	0x0	R/W
		6	IRQEN_DACPLLLOCK	1 0	Enable the IRQ of DAC PLL lock detection. If IRQEN_DACPLLLOCK goes high, it latches and pulls IRQ low. IRQEN_DACPLLLOCK shows current status.	0x0	R/W
		5	RESERVED		Reserved.	0x0	R/W
		4	IRQEN_SERPLLLIST	1	Enable the IRQ of SERDES PLL lost detection. If IRQEN_SERPLLLIST goes high, it latches and	0x0	R/W

Addr.	Name	Bits	Bit Name	Settings	Description	Reset	Access
					pulls IRQ low.		
				0	IRQEN_SERPLLLOST shows current status.		
		3	IRQEN_SERPLLLOCK	1	Enable the IRQ of SERDES PLL lock detection. If IRQEN_SERPLLLOCK goes high, it latches and pulls IRQ low.	0x0	R/W
				0	IRQEN_SERPLLLOCK shows current status.		
		2	RESERVED		Reserved.	0x0	R/W
		1	IRQEN_LANEFIFOERR	1	Enable the IRQ of lane FIFO error detection. If IRQEN_LANEFIFOERR goes high, it latches and pulls IRQ low.	0x0	R/W
				0	IRQEN_LANEFIFOERR shows current status.		
		0	IRQEN_DRDLFIFOERR	1	Enable the IRQ of DRDL FIFO error detection. If IRQEN_DRDLFIFOERR goes high, it latches and pulls IRQ low.	0x0	R/W
				0	IRQEN_DRDLFIFOERR shows current status.		
0x020	IRQ_ENABLE1	7	IRQEN_PARMBAD	1	Enable the interrupt of bad parameter. If IRQEN_PARMBAD goes high, it latches and pulls IRQ low.	0x0	R/W
				0	IRQEN_PARMBAD shows current status.		
		6	IRQEN_LANEFIFO	1	Enable the interrupt of lane FIFO empty/full. If IRQEN_LANEFIFO goes high, it latches and pulls IRQ low.	0x0	R/W
				0	IRQEN_LANEFIFO shows current status.		
		5	IRQEN_DLYBUF	1	Enable the interrupt of delay buffer empty/full. If IRQEN_DLYBUF goes high, it latches and pulls IRQ low.	0x0	R/W
				0	IRQEN_DLYBUF shows current status.		
		4	IRQEN_DATAREADY	1	Enable the interrupt of data ready. If IRQEN_DATAREADY goes high, it latches and pulls IRQ low.	0x0	R/W
				0	IRQEN_DATAREADY shows current status.		
		3	IRQEN_OVERFLOW	1	Enable the interrupt of data path modules overflow. If IRQEN_OVERFLOW goes high, it latches and pulls IRQ low.	0x0	R/W
				0	IRQEN_OVERFLOW shows current status.		
		2	RESERVED		Reserved.	0x0	R/W
		1	IRQEN_PRBSQ	1	Enable the interrupt of Q DAC PRBS. If IRQEN_PRBSQ goes high, it latches and pulls IRQ low.	0x0	R/W
				0	IRQEN_PRBSQ shows current status.		
		0	IRQEN_PRBSI	1	Enable the interrupt of Q DAC PRBS. If IRQEN_PRBSI goes high, it latches and pulls $\overline{\text{IRQ}}$ low.	0x0	R/W
				0	IRQEN_PRBSI shows current status.		
0x021	IRQ_ENABLE2	7	IRQEN_PDPERR	1	Enable the interrupt of PDP error. If IRQEN_PDPERR goes high, it latches and pulls IRQ low.	0x0	R/W
				0	IRQEN_PDPERR shows current status.		
		[6:5]	RESERVED		Reserved.	0x0	R
		4	IRQEN_NCOALIGN	1	Enable the interrupt of NCO alignment. If IRQEN_NCOALIGN goes high, it latches and pulls IRQ low.	0x0	R/W
				0	IRQEN_NCOALIGN shows current status.		
		3	IRQEN_SYNCLOCK	1	Enable the interrupt of link alignment lock. If IRQEN_SYNCLOCK goes high, it latches and pulls IRQ low.	0x0	R/W
				0	IRQEN_SYNCLOCK shows current status.		
		2	IRQEN_SYNCROTATE		Enable the interrupt of link alignment rotate.	0x0	R/W

Addr.	Name	Bits	Bit Name	Settings	Description	Reset	Access
				1	If IRQEN_SYNCROTATE goes high, it latches and pulls IRQ low.		
				0	IRQEN_SYNCROTATE shows current status.		
		1	IRQEN_SYNCWLIM		Enable the interrupt of link alignment outside limit window.	0x0	R/W
				1	If IRQEN_SYNCWLIM goes high, it latches and pulls IRQ low.		
				0	IRQEN_SYNCWLIM shows current status.		
		0	IRQEN_SYNCTRIP		Enable the interrupt of link alignment tripped.	0x0	R/W
				1	If SYNCTRIP goes high, it latches and pulls $\overline{\text{IRQ}}$ low.		
				0	SYNCTRIP shows current status.		
0x023	IRQ_STATUS0	7	DACPLLLOST		DAC PLL lost status. If IRQEN_DACPLLLOST is low, this bit shows current status. If not, this bit latches on a rising edge and pulls IRQ low. When latched, write a 1 to clear this bit.	0x0	R/W
				1	DAC PLL lock was lost.		
		6	DACPLLLOCK		DAC PLL lock status. If IRQEN_DACPLLLOCK is low, this bit shows current status. If not, this bit latches on a rising edge and pulls $\overline{\text{IRQ}}$ low. When latched, write a 1 to clear this bit.	0x0	R/W
				1	DAC PLL locked.		
		5	RESERVED		Reserved.	0x0	R
		4	SERPLLLOST		SERDES PLL lost status. If IRQEN_SERPLLLOST is low, this bit shows current status. If not, this bit latches on a rising edge and pulls IRQ low. When latched, write a 1 to clear this bit.	0x0	R/W
				1	SERDES PLL lock was lost.		
		3	SERPLLLOCK		SERDES PLL lock status. If IRQEN_SERPLLLOCK is low, this bit shows current status. If not, this bit latches on a rising edge and pulls $\overline{\text{IRQ}}$ low. When latched, write a 1 to clear this bit.	0x0	R/W
				1	SERDES PLL locked.		
		2	RESERVED		Reserved.	0x0	R
		1	LANEFIFOERR		Lane FIFO error status. If IRQEN_LANEFIFOERR is low, this bit shows current status. If not, this bit latches on a rising edge and pulls IRQ low. A lane FIFO error occurs when there is a full or empty condition on any of the FIFOs between the deserializer block and the digital core. This error requires a link disable and reenable to remove it. The status of the lane FIFOs can be found in Register 0x30C (FIFO full), and Register 0x30D (FIFO empty).	0x0	R/W
				1	Lane FIFO error.		
		0	DRDLFIFOERR		DRDL FIFO status. If IRQEN_DRDLFIFOERR is low, this bit shows current status. If not, this bit latches on a rising edge and pulls $\overline{\text{IRQ}}$ low. When latched, write a 1 to clear this bit.	0x0	R/W
				1	DRDL FIFO error.		
0x024	IRQ_STATUS1	7	PARMBAD		BAD parameter status. If IRQEN_PARBAD is low, this bit shows current status. If not, this bit latches on a rising edge and pulls IRQ low. When latched, write a 1 to clear this bit.	0x0	R/W
				1	Bad parameter.		
		6	LANEFIFO		Lane FIFO empty/full Status. If IRQEN_LANEFIFO is low, this bit shows current status. If not, this bit latches on a rising edge and pulls $\overline{\text{IRQ}}$ low. When latched, write a 1 to clear this bit.	0x0	R/W
				1	Lane FIFO empty/full.		
		5	DLYBUF		Delay buffer empty/full Status. If IRQEN_DLYBUF is low, this bit shows current status. If not, this bit latches on a rising edge and pulls $\overline{\text{IRQ}}$ low. When latched, write a 1 to clear this bit.	0x0	R/W

Addr.	Name	Bits	Bit Name	Settings	Description	Reset	Access
				1	Delay buffer empty/full.		
		4	DATAREADY	1	Data ready status. If IRQEN_DATAREADY is low, this bit shows current status. If not, this bit latches on a rising edge and pulls $\overline{\text{IRQ}}$ low. When latched, write a 1 to clear this bit.	0x0	R/W
		3	OVERFLOW		Data path over flow interrupt.	0x0	R/W
		2	RESERVED		Reserved.	0x0	R
		1	PRBSQ	1	DACQ PRBS error status. If IRQEN_PRBSQ is low, this bit shows current status. If not, this bit latches on a rising edge and pulls $\overline{\text{IRQ}}$ low. When latched, write a 1 to clear this bit.	0x0	R/W
		0	PRBSI	1	DACI PRBS error status. If IRQEN_PRBSI is low, this bit shows current status. If not, this bit latches on a rising edge and pulls $\overline{\text{IRQ}}$ low. When latched, write a 1 to clear this bit.	0x0	R/W
0x025	IRQ_STATUS2	7	PAERR	1	PDP error. If IRQEN_PAERR is low, this bit shows current status. If not, this bit latches on a rising edge and pulls $\overline{\text{IRQ}}$ low. When latched, write a 1 to clear this bit.	0x0	R/W
		[6:5]	RESERVED		Reserved.	0x0	R/W
		4	NCOALIGN	1	NCO align tripped status. If IRQEN_NCOALIGN is low, this bit shows current status. If not, this bit latches on a rising edge and pulls $\overline{\text{IRQ}}$ low. When latched, write a 1 to clear this bit.	0x0	R/W
		3	SYNCLOCK	1	LMFC alignment locked status. If IRQEN_SYNCLOCK is low, this bit shows current status. If not, this bit latches on a rising edge and pulls $\overline{\text{IRQ}}$ low. When latched, write a 1 to clear this bit.	0x0	R/W
		2	SYNCROTATE	1	LMFC alignment rotate status. If IRQEN_SYNCROTATE is low, this bit shows current status. If not, this bit latches on a rising edge and pulls $\overline{\text{IRQ}}$ low. When latched, write a 1 to clear this bit.	0x0	R/W
		1	SYNCWLIM	1	LMFC alignment rotated.		
		0	SYNCTRIP	1	LMFC alignment tripped status. If IRQEN_SYNCTRIP is low, this bit shows current status. If not, this bit latches on a rising edge and pulls $\overline{\text{IRQ}}$ low. When latched, write a 1 to clear this bit.	0x0	R/W
0x026	OVERFLOW_STATUS0	7	PFIR_OVERFLOW		The overflow status of PFIR filter.	0x0	R
		6	INT1_OVERFLOW		The overflow status of INT1 filter.	0x0	R
		5	INT2_OVERFLOW		The overflow status of INT2 filter.	0x0	R
		4	INT3_OVERFLOW		The overflow status of INT3 filter.	0x0	R
		3	COARSE_MOD_BY8_OVERFLOW		The overflow status of $f_s/8$ coarse modulation.	0x0	R
		2	FINE_MOD_OVERFLOW		The overflow status of fine modulation.	0x0	R
		1	PHASE_ADJ_OVERFLOW		The overflow status of phase adjustment.	0x0	R
		0	GAIN_ADJ_OVERFLOW		The overflow status of gain adjustment.	0x0	R
0x027	OVERFLOW_STATUS1	[7:1]	RESERVED		Reserved.	0x0	R
		0	DC_OFFSET_OVERFLOW		The overflow status of DC offset.	0x0	R

Addr.	Name	Bits	Bit Name	Settings	Description	Reset	Access
0x030	JESD_CHECKS	[7:6]	RESERVED		Reserved.	0x0	R
		5	ERR_DLYOVER	1	Error: LMFC_DELAY > JESD_K parameter. LMFC_DELAY > JESD_K.	0x0	R
		4	ERR_WINLIMIT	1	Unsupported window limit. Unsupported SYSREF window limit.	0x0	R
		3	ERR_JESDBAD	1	Unsupported M/L/S/F selection. This JESD combination is not supported.	0x0	R
		2	ERR_KUNSUPP	1	Unsupported K values. 16 and 32 are supported. K value unsupported.	0x0	R
		1	ERR_SUBCLASS	1	Unsupported subclass value. 0 and 1 are supported. Unsupported subclass value.	0x0	R
		0	ERR_INTSUPP	1	Unsupported interpolation rate factor. 1, 2, 4, 8 are supported. Unsupported interpolation rate factor.	0x0	R
0x032	SYNC_DACDELAY_L	[7:0]	DAC_DELAY_L		Sync DAC delay.	0x0	R/W
0x033	SYNC_DACDELAY_H	[7:1]	RESERVED		Reserved.	0x0	R
		0	DAC_DELAY_H		DAC delay, Bit 8.	0x0	R/W
0x034	SYNC_ERRWINDOW	[7:3]	RESERVED		Reserved.	0x0	R
		[2:0]	ERRWINDOW		LMFC sync error window. The error window allows the SYSREF± sample phase to vary within the confines of the window without triggering a clock adjustment. This is useful if SYSREF± cannot be guaranteed to always arrive in the same period of the device clock associated with the target phase. Error window tolerance = ± ERRWINDOW in DACCLKs.  000 Error window tolerance ± 0. 001 Error window tolerance ± 1. 010 Error window tolerance ± 2. 011 Error window tolerance ± 3. 100 Error window tolerance ± 4. 101 Error window tolerance ± 5. 110 Error window tolerance ± 6. 111 Error window tolerance ± 7.	0x0	R/W
0x035	SYNC_DLYCOUNT	[7:0]	DLYCOUNT		Pulse mode delay. Specifies minimum number of LMFC counts before a SYSREF± sync cycle is considered active.	0x0	R/W
0x036	SYNC_REFCOUNT	[7:0]	REFCOUNT		Pulse mode reference count. Specifies count of SYSREF± pulses to cause a rotate.	0x0	R/W
0x038	SYNC_LASTERR_L	[7:0]	LASTERROR_L		Sync last error, Bits[7:0].	0x0	R
0x039	SYNC_LASTERR_H	7	LASTUNDER	1	LMFC sync last error under flag. Last phase error was beyond lower window tolerance boundary.	0x0	R
		6	LASTOVER	1	LMFC sync last error over flag. Last phase error was beyond upper window tolerance boundary.	0x0	R
		[5:1]	RESERVED		Reserved.	0x0	R
		0	LASTERROR_H		Sync last error, Bit 8 and flags.	0x0	R
0x03A	SYNC_CONTROL	7	SYNCENABLE	1 0	Sync logic enable. Enable sync logic. Disable sync logic.	0x0	R/W
		6	SYNCARM	1	Sync arm strobe. Sync one shot armed.	0x0	R/W
		5	SYNCCLRSTKY		LMFC sync sticky bit clear. On a rising edge, this bit clears SYNC_ROTATE and SYNC_TRIP.	0x0	R/W
		4	SYNCCLRLAST		LMFC sync clear last error. On a rising edge, this bit clears LASTERROR, LASTUNDER, and LASTOVER.	0x0	R/W
		[3:0]	SYNCMODE	0b0001	LMFC sync mode. Sync one shot mode.	0x0	R/W

Addr.	Name	Bits	Bit Name	Settings	Description	Reset	Access
				0b0010 0b1000 0b1001	Sync continuous mode. Sync monitor only mode. Sync one shot, then monitor.		
0x03B	SYNC_STATUS	7	SYNCBUSY	1	Sync machine busy. Sync logic SM is busy.	0x0	R
		[6:4]	RESERVED		Reserved.	0x0	R
		3	SYNCKLOCK	1	Sync alignment locked. Sync logic aligned within window.	0x0	R
		2	SYNCROTATE	1	Sync rotated. Sync logic rotated with SYSREF± (sticky).	0x0	R
		1	SYNCWLIM	1	Sync alignment limit Range. Phase error outside window threshold.	0x0	R
		0	SYNCTRIIP	1	Sync tripped after arming. Sync received SYSREF± pulse (sticky).	0x0	R
0x03C	SYNC_CURRERR_L	[7:0]	CURRERROR_L		LMFC sync alignment error. 9-bit twos complement value that represents the phase error in number of DAC clock cycles (that is, number of DAC clocks between LMFC edge and SYSREF± edge). When an adjustment of the clocks is made on any given SYSREF±, the value of the phase error is placed into SYNC_LASTERR, and SYNC_CURRERR is forced to 0.	0x0	R
0x03D	SYNC_CURRERR_H	7	CURRUNDER	1	LMFC sync current error under flag. Current phase error is beyond lower window tolerance boundary.	0x0	R
		6	CURROVER	1	LMFC sync current error over flag. Current phase error is beyond upper window tolerance boundary.	0x0	R
		[5:1]	RESERVED		Reserved.	0x0	R
		0	CURRERROR_H		SYNC_CURRERR, Bit 8.	0x0	R
0x03E	ERROR_THERM	7	THRMOLD	1	Error is from a prior sample. From an old sample.	0x0	R
		[6:5]	RESERVED		Reserved.	0x0	R
		4	THRMOVER	1	Error > +WinLimit. Error > +WinLimit.	0x0	R
		3	THRMPOS	1	Error > 0. Error > 0.	0x0	R
		2	THRMZERO	1	Error = 0. Error = 0.	0x0	R
		1	THRMNEG	1	Error < 0. Error < 0.	0x0	R
		0	THRMUNDER	1	Error < -WinLimit. Error < -WinLimit.	0x0	R
0x040	DAC_GAIN1_I	[7:2]	RESERVED		Reserved.	0x0	R/W
		[1:0]	DACFSC_I[9:8]		2 MSBs of I DAC gain. 111111111 = 20 mA. 000000000 = 4 mA.	0x3	R/W
0x041	DAC_GAIN0_I	[7:0]	DACFSC_I[7:0]		8 LSBs of I DAC gain.	0xFF	R/W
0x042	DAC_GAIN1_Q	[7:2]	RESERVED		Reserved.	0x0	R/W
		[1:0]	DACFSC_Q[9:8]		2 MSBs of Q DAC gain. 111111111 = 20 mA. 000000000 = 4 mA.	0x3	R/W
0x043	DAC_GAIN0_Q	[7:0]	DACFSC_Q[7:0]		8 LSBs of Q DAC Gain.	0xFF	R/W
0x047	COARSE_GROUP_DLY	[7:4]	COARSE_GROUP_DLY_I		Coarse Group Delay. 0 = minimum delay, 15 = maximum delay. The range of the delay is -4 DAC clock periods to +3 DAC clock periods and the resolution is 1/2 DAC clock period.	0x08	R/W

Addr.	Name	Bits	Bit Name	Settings	Description	Reset	Access
		[3:1]	COARSE_GROUP_DLY_Q		Coarse Group Delay. 0 = minimum delay, 15 = maximum delay. The range of the delay is -4 DAC clock periods to +3 DAC clock periods and the resolution is 1/2 DAC clock period.	0x08	
0x050	NCOALIGN_MODE	7	NCO_ALIGN_ARM		Arm NCO align. On a rising edge, arms the NCO align operation.	0x0	R/W
		6	RESERVED		Reserved.	0x0	R
		5	NCO_ALIGN_MTCH	1 0	NCO align data match. Key NCO align data match. If finished, NCO not aligned on data match.	0x0	R
		4	NCO_ALIGN_PASS	1 0	NCO align pass. NCO align takes effect. Clear not taken effect yet.	0x0	R
		3	NCO_ALIGN_FAIL	1 0	NCO align fail. NCO reset during rotate. Not finished yet.	0x0	R
		2	RESERVED		Reserved.	0x0	R
		[1:0]	NCO_ALIGN_MODE	00 10 01	NCO align mode. NCO align disabled. NCO align on data key. NCO align on SYSREF±.	0x0	R/W
0x051	NCOKEY_ILSB	[7:0]	NCOKEYI[7:0]		NCO data key LSB for I.	0x0	R/W
0x052	NCOKEY_IMSB	[7:0]	NCOKEYI[15:8]		NCO data key MSB for I.	0x0	R/W
0x053	NCOKEY_QLSB	[7:0]	NCOKEYQ[7:0]		NCO data key LSB for Q.	0x0	R/W
0x054	NCOKEY_QMSB	[7:0]	NCOKEYQ[15:8]		NCO data key MSB for Q.	0x0	R/W
0x060	PDP_THRES0	[7:0]	PDP_THRESHOLD[7:0]		PDP_THRESHOLD is the average power threshold for comparison. If the moving average of signal power crosses this threshold, PDP_PROTECT is set high.	0x0	R/W
0x061	PDP_THRES1	[7:5]	RESERVED		Reserved.	0x0	R
		[4:0]	PDP_THRESHOLD[12:8]		See Register 0x060.	0x0	R/W
0x062	PDP_AVG_TIME	7	PDP_ENABLE	1	Enable average power calculation.	0x0	R/W
		[6:4]	RESERVED		Reserved.	0x0	R
		[3:0]	PDP_AVG_TIME		Can be set from 0 to 10. Averages across $2^{(9+PDP\_AVG\_TIME)}$ IQ sample pairs.	0x0	R/W
0x063	PDP_POWER0	[7:0]	PDP_POWER[7:0]		If PDP_POWER has not gone over PDP_THRESHOLD, PDP_POWER reads back the moving average of the signal power ( $I^2 + Q^2$ ). Only 6 data MSBs are used in calculating power.	0x0	R
0x064	PDP_POWER1	[7:5]	RESERVED		Reserved.	0x0	R
		[4:0]	PDP_POWER[12:8]		See Register 0x063.	0x0	R
0x065	PA_OFFGAIN0	7	EN_UKCIROFFGAIN		Enable off gain function when unexpected K-characters error counter reaches the threshold.	0x0	R/W
		[6:2]	RESERVED		Reserved.	0x0	R/W
		1	EN_DELAYBUFFEROFF-GAIN		Enable off gain function when delay buffer has error.	0x0	R/W
		0	EN_LANEFIROFFGAIN		Enable off gain when lane FIFO has error.	0x0	R/W
0x066	PA_OFFGAIN1	7	EN_CMMIROFFGAIN		Enable off gain function when ILAS configuration on Lane 0 is mismatched.	0x0	R/W
		6	EN_CGSIROFGAIN		Enable off gain function when CGS failed.	0x0	R/W
		5	EN_FSIROFFGAIN		Enable off gain function when frame synchronization failed.	0x0	R/W
		4	EN_GCSIROFFGAIN		Enable off gain function when checksum failed.	0x0	R/W
		3	EN_ILSIROFFGAIN		Enable off gain function when initial lane alignment failed.	0x0	R/W
		2	EN_ILDIRQOFFGAIN		Enable off gain function when lane deskew failed.	0x0	R/W
		1	EN_DISIROFFGAIN		Enable off gain function when disparity error count exceeds the threshold.	0x0	R/W
		0	EN_NITIROFFGAIN		Enable off gain because NIT error count exceeded the threshold.	0x0	R/W

Addr.	Name	Bits	Bit Name	Settings	Description	Reset	Access
0x080	CLKCFG0	[7:3]	RESERVED		Reserved.	0x0	R/W
		2	DUTY_EN		Enable duty cycle control of clock receiver	0x1	R/W
		[1:0]	RESERVED		Reserved.	0x0	R/W
0x081	SYSREF_CTRL0	[7:5]	RESERVED		Reserved.	0x0	R/W
		4	PD_SYSREF		Power-down SYSREF± buffer. This bit powers down the SYSREF± receiver. For Subclass 1 operation to work, this buffer must be enabled.	0x1	R/W
		3	HYS_ON		Hysteresis enabled. This bit enables the programmable hysteresis control for the SYSREF± receiver. Using hysteresis gives some noise resistance, but delays the SYSREF± edge an amount depending on HYS_CNTRL and the SYSREF± edge rate. The SYSREF± KOW is not guaranteed when using hysteresis.	0x0	R/W
		2	SYSREF_RISE	0 1	Select DAC clock edge to sample SYSREF±. Use falling edge of DAC clock to sample SYSREF± for alignment Use rising edge of DAC clock to sample SYSREF± for alignment	0x0	R/W
		[1:0]	HYS_CNTRL1		Hysteresis control, Bits[9:8]. HYS_CNTRL is a 10-bit thermometer-coded number. Each bit set adds 10 mV of differential hysteresis to the SYSREF± receiver.	0x0	R/W
0x082	SYSREF_CTRL1	[7:0]	HYS_CNTRL0		Hysteresis control, Bits[7:0].	0x0	R/W
0x083	DACPLLCNTRL	7	RECAL_DACPLL		Recalibrate DAC PLL. On a rising edge of this bit, recalibrate the DAC PLL.	0x0	R/W
		[6:5]	RESERVED		Reserved.	0x0	R/W
		4	ENABLE_DACPLL		Synthesizer enable. This bit enables and calibrates the DAC PLL.	0x0	R/W
		[3:0]	RESERVED		Reserved.	0x0	R/W
0x084	DACPLLSTATUS	7	CP_OVERRANGE_H	1	Charge pump high overrange. This bit indicates that the DAC PLL hit the upper edge of its operating band. Recalibrate. Control voltage too high.	0x0	R
		6	CP_OVERRANGE_L	1	This bit indicates that the DAC PLL hit the lower edge of its operating band. Recalibrate. Control voltage too low.	0x0	R
		5	CP_CAL_VALID	0 1	Charge pump calibration valid If CP_CAL_EN is low, this stays low. If CP_CAL_EN high (def), this happens when charge pump is calibrated.	0x0	R
		4	VCO_CAL_PROGRESS	0 1	VCO calibration in progress. VCO not calibrating. VCO calibrating.	0x0	R
		3	CURRENTS_READY	0 1	Indicating DAC PLL bias current status. Bias not ready. Bias ready.	0x0	R
		2	RESERVED		Reserved.	0x0	R/W
		1	DAC_PLL_LOCK		DAC PLL lock bit. This bit is set high by the PLL when it has achieved lock.	0x0	R
		0	RESERVED		Reserved.	0x0	R/W
0x085	DACINTEGERWORD0	[7:0]	B_COUNT		Integer division word. This bit controls the integer feedback divider for the DAC PLL. Determine the frequency of the DAC clock by the following equations (see the Clock Multiplication Relationships section for more details): $f_{DAC} = f_{REF}/(REF\_DIVRATE) \times 2 \times B\_COUNT$ $f_{VCO} = f_{REF}/(REF\_DIVRATE) \times 2 \times B\_COUNT \times LO\_DIV\_MODE$ Minimum value is 6.	0x6	R/W
0x087	DACLOOPFLT1	[7:4]	LF_C2_WORD		C2 control word.	0x8	R/W
		[3:0]	LF_C1_WORD		C1 control word.	0x8	R/W

Addr.	Name	Bits	Bit Name	Settings	Description	Reset	Access
0x088	DACLOOPFLT2	[7:4]	LF_R1_WORD		R1 control word.	0x8	R/W
		[3:0]	LF_C3_WORD		C3 control word.	0x8	R/W
0x089	DACLOOPFLT3	7	LF_BYPASS_R3		Bypass R3 resistor. When this bit is set, bypass the R3 capacitor (set to 0 pF) when R3_WORD is set to 0.	0x0	R/W
		6	LF_BYPASS_R1		Bypass R1 resistor. When this bit is set, bypass the R1 capacitor (set to 0 pF) when R1_WORD is set to 0.	0x0	R/W
		5	LF_BYPASS_C2		Bypass C2 capacitor. When this bit is set, bypass the C2 capacitor (set to 0 pF) when C2_WORD is set to 0.	0x0	R/W
		4	LF_BYPASS_C1		Bypass C1 capacitor. When this bit is set, bypass the C1 capacitor (set to 0 pF) when C1_WORD is set to 0.	0x0	R/W
		[3:0]	LF_R3_WORD		R3 control word.	0x8	R/W
0x08A	DACPCNTRL	[7:6]	RESERVED		Reserved.	0x0	R/W
		[5:0]	CP_CURRENT		Charge pump current control.	0x20	R/W
0x08B	DACLOGENCTRL	[7:2]	RESERVED		Reserved.	0x0	R/W
		[1:0]	LO_DIV_MODE		This range controls the RF clock divider between the VCO and DAC clock rates. The options are 4x, 8x, or 16x division. Choose the LO_DIV_MODE so that $6\text{ GHz} < f_{\text{VCO}} < 12\text{ GHz}$ (see the Clock Multiplication Relationships section for more details): 01 DAC clock = VCO/4 10 DAC clock = VCO/8 11 DAC clock = VCO/16	0x0	R/W
0x08C	DACLDOCNTRL1	[7:3]	RESERVED		Reserved.	0x0	R/W
		[2:0]	REF_DIV_MODE		Reference clock division ratio. This field controls the amount of division that is done to the input clock at the REFCLK+/ REFCLK- pins before it is presented to the PLL as a reference clock. The reference clock frequency must be between 35 MHz and 80 MHz, but the REFCLK+/REFCLK- input frequency can range from 35 MHz to 1 GHz. The user sets this division to achieve a 35 MHz to 80 MHz PLL reference frequency. For more details see the Clock Multiplication Relationships section. 001 2x. 010 4x. 011 8x. 100 16x.	0x0	R/W
0x08E	CLK_DETECT	[7:5]	RESERVED		Reserved.	0x0	R/W
		4	PD_DAC_ONDIFF		Automatically power-down DACs if clock is not differential. 0 Only report clock errors. 1 Automatically force DAC PD is clock if not differential.	0x0	R/W
		3	PD_DAC_ONDET		Automatically power-down DACs if clock is lost. 0 Only report clock errors. 1 Automatically force DAC PD if clock is lost.	0x0	R/W
		2	CLK_ON		Indicate if DACCLK is on. 0 The clock is not on. 1 The clock is on.	0x0	R
		1	IS_DIFF		Indicate if the clock is differential. 0 The clock is not differential. 1 The clock is differential.	0x0	R
		0	CLK_DET_EN		Enable Clock Detector. 0 Disable clock detect circuit. 1 Enable clock detect circuit.	0x0	R/W
0x0F7	DIG_TEST0	[7:2]	RESERVED		Reserved.	0x7	R/W
		1	DC_TEST_MOD		DC test mode enable.	0x0	R/W
		0	DIG_CLK_PD		Power down top digital clock.	0x0	R/W
0x0F8	DC_TEST_VALUEI0	[7:0]	DC_TEST_VALUEI[7:0]		DC value LSB of dc test mode for I DAC.	0x0	R/W

Addr.	Name	Bits	Bit Name	Settings	Description	Reset	Access
0x0F9	DC_TEST_VALUEI1	[7:0]	DC_TEST_VALUEI [15:8]		DC value MSB of dc test mode for I DAC.	0x0	R/W
0x0FA	DC_TEST_VALUEQ0	[7:0]	DC_TEST_VALUEEQ[7:0]		DC value LSB of dc test mode for Q DAC.	0x0	R/W
0x0FB	DC_TEST_VALUEQ1	[7:0]	DC_TEST_VALUEEQ[15:8]		DC value MSB of dc test mode for Q DAC.	0x0	R/W
0x110	DATA_FORMAT	7	BINARY_FORMAT	0 1	Binary or twos complementary format on the data bus. 0 Input data is twos complement. 1 Input data is offset binary.	0x0	R/W
		[6:0]	RESERVED		Reserved.	0x0	R/W
0x111	DATAPATH_CTRL	7	INVSINC_ENABLE	1	Enable inverse sinc filter.	0x0	R/W
		6	RESERVED		Reserved.	0x0	R/W
		5	DIG_GAIN_ENABLE	1	Enable digital gain function.	0x1	R/W
		4	PHASE_ADJ_ENABLE	1	Enable phase adjust compensation.	0x0	R/W
		[3:2]	MODULATION_TYPE	00 01 10 11	Selects type Of modulation operation. 00 No modulation. 01 NCO fine modulation (uses FTW). 10 fs/4 coarse modulation. 11 fs/8 coarse modulation.	0x0	R/W
		1	SEL_SIDE BAND		Spectrum inversion control. Can be used with both fine modulation and coarse modulation. This causes the negative sideband to be selected and is equivalent to changing the sign of FTW.	0x0	R/W
		0	RESERVED		Reserved.	0x0	R/W
0x112	INTERP_MODE	7	SINGLE_DAC_EN		Enable single DAC mode. If this bit is high, only Mode 9 and Mode 10 in Table 43 can be supported and Q DAC powers down automatically.	0x0	R/W
		[6:2]	RESERVED		Reserved.	0x0	R/W
		[1:0]	INTERP_MODE	00 01 10 11	Interpolation mode. 00 1× (bypass). 01 2× mode. 10 4× mode. 11 8× mode.	0x1	R/W
0x113	NCO_FTW_UPDATE	[7:2]	RESERVED		Reserved.	0x0	R/W
		1	FTW_UPDATE_ACK		Frequency tuning word update acknowledge. This readback is high when an FTW has been updated.	0x0	R
		0	FTW_UPDATE_REQ		Frequency tuning word update request from SPI. Unlike most registers, those relating to fine NCO modulation (Register 0x114 to Register 0x11B) are not updated immediately upon writing to them. Once the desired FTW and phase offset values are written, set this bit. These registers update on the rising edge of this bit. It is only after this update that the internal state matches Register 0x114 to Register 0x11B. Confirmation that this update has occurred can be made by reading back Bit 1 of this register and ensuring it is set high for the update acknowledge.	0x0	R/W
0x114	FTW0	[7:0]	FTW[7:0]		NCO frequency tuning word.	0x0	R/W
0x115	FTW1	[7:0]	FTW[15:8]		NCO frequency tuning word.	0x0	R/W
0x116	FTW2	[7:0]	FTW[23:16]		NCO frequency tuning word.	0x0	R/W
0x117	FTW3	[7:0]	FTW[31:24]		NCO frequency tuning word.	0x0	R/W
0x118	FTW4	[7:0]	FTW[39:32]		NCO frequency tuning word.	0x0	R/W
0x119	FTW5	[7:0]	FTW[47:40]		NCO frequency tuning word.	0x10	R/W
0x11A	NCO_PHASE_OFFSET0	[7:0]	NCO_PHASE_OFFSET[7:0]		8 LSBs of NCO Phase Offset. NCO_PHASE_OFFSET changes the phase of both I and Q data, and is only functional when using NCO fine modulation. It is a 16-bit, twos complement number ranging from $-180^\circ$ to $+180^\circ$ in steps of $0.0055^\circ$ .	0x0	R/W
0x11B	NCO_PHASE_OFFSET1	[7:0]	NCO_PHASE_OFFSET[15:8]		8 MSBs of NCO phase offset.	0x0	R/W
0x11C	IQ_PHASE_ADJ0	[7:0]	PHASE_ADJ[7:0]		8 LSBs of phase compensation word. Phase compensation changes the phase between the I and Q data. PHASE_ADJ is a 13-bit, twos	0x0	R/W

Addr.	Name	Bits	Bit Name	Settings	Description	Reset	Access
					complement value. The control ranges from $-14^\circ$ to $+14^\circ$ with $0.0035^\circ$ resolution steps.		
0x11D	IQ_PHASE_ADJ1	[7:5]	RESERVED		Reserved.	0x0	R/W
		[4:0]	PHASE_ADJ[12:8]		5 MSBs of phase compensation word.		
0x11F	TXEN_SM_0	[7:6]	FALL_COUNTERS		Fall Counters. The number of counters to use to delay TX_PROTECT fall from TXEN falling edge. Must be set to 1 or 2.	0x2	R/W
		[5:4]	RISE_COUNTERS		Rise Counters. The number of counters to use to delay TX_PROTECT rise from TXEN rising edge.	0x0	R/W
		3	RESERVED		Reserved.	0x0	R/W
		2	PROTECT_OUT_INVERT	0	PROTECT_OUT invert. PROTECT_OUT is low when error happens. Suitable for enabling downstream components during transmission.	0x0	R/W
		1	RESERVED	1	PROTECT_OUT is high when error happens. Suitable for disabling downstream components when not transmitting.		
		0	TXEN_SM_EN		Enable TXEN state machine.	0x1	R/W
0x125	DACOUT_ON_DOWN	[7:2]	RESERVED		Reserved.	0x0	R/W
		1	DACOUT_SHUTDOWN		Shut down DAC output. 1 means DAC is shut down manually. 1 = shut down, 0 = enable DAC.	0x0	R/W
		0	DACOUT_ON_TRIGGER		Turn on DAC output manually. Self clear signal. Cannot turn on the DAC if DAC is shut down by Bit 1, DACOUT_SHUTDOWN.	0x0	R/W
0x12C	DACOFF	7	PROTECT_MODE		If this bit is high then DAC is in protect mode, and DAC is shut down automatically when some errors happen.	0x1	R/W
		[6:1]	RESERVED		Reserved.	0x0	R/W
		0	DACOFF_AVG_PW		If this bit is high and Bit 7 is high, then if input average power is bigger than given threshold (see Register 0x60, Register 0x61) within a given time window, DAC output shuts down automatically.	0x1	R/W
0x12F	DIE_TEMP_CTRL0	7	RESERVED		Reserved.	0x0	R/W
		[6:4]	FS_CURRENT	000 111	Aux ADC full-scale current (LSB 12.5 $\mu$ A). Must write the default value for proper operation. Lowest current (50 $\mu$ A). Highest current (137.5 $\mu$ A).	0x2	R/W
		[3:1]	RESERVED		Reserved.	0x0	R/W
		0	TEMP_SENSOR_ENABLE		1 = Enable temperature sensor.	0x0	R/W
0x132	DIE_TEMP0	[7:0]	DIE_TEMP[7:0]		Die temperature code readback.	0x0	R
0x133	DIE_TEMP1	[7:0]	DIE_TEMP[15:8]		Die temperature code readback.	0x0	R
0x134	DIE_TEMP_UPDATE	[7:1]	RESERVED		Reserved.	0x0	R/W
		0	DIE_TEMP_UPDATE		Die temperature code update. On a rising edge of this bit, a new temperature code is generated.	0x0	R/W
0x135	DC_OFFSET_CTRL	[7:1]	RESERVED		Reserved.	0x0	R/W
		0	DC_OFFSET_ON	1	Enables dc offset module.	0x0	R/W
0x136	IPATH_DC_OFFSET_1PART0	[7:0]	LSB_OFFSET_I[7:0]		8 LSBs of I path DC offset. LSB_OFFSET_I is a 16-bit, twos complement number that is added to incoming data.	0x0	R/W
0x137	IPATH_DC_OFFSET_1PART1	[7:0]	LSB_OFFSET_I[15:8]		8 MSBs of I path DC offset. Offset. LSB_OFFSET_I is a 16-bit, twos complement number that is added to incoming I data.	0x0	R/W
0x138	QPATH_DC_OFFSET_1PART0	[7:0]	LSB_OFFSET_Q[7:0]		8 LSBs of Q path DC offset. LSB_OFFSET_Q is a 16-bit, twos complement number that is added to incoming Q data.	0x0	R/W
0x139	QPATH_DC_OFFSET_1PART1	[7:0]	LSB_OFFSET_Q[15:8]		8 MSBs of Q path DC offset. LSB_OFFSET_Q is a 16-bit, twos complement number that is added to incoming Q data.	0x0	R/W
0x13A	IPATH_DC_OFFSET_2PART	[7:5]	RESERVED		Reserved.	0x0	R/W
		[4:0]	SIXTEENTH_OFFSET_I		SIXTEENTH_OFFSET_I is a 5-bit twos complement number in 16ths of an LSB that is added to	0x0	R/W

Addr.	Name	Bits	Bit Name	Settings	Description	Reset	Access
				x	incoming I data. x/16 LSB DC offset.		
0x13B	QPATH_DC_OFFSET_2PART	[7:5]	RESERVED		Reserved.	0x0	R/W
		[4:0]	SIXTEENTH_OFFSET_Q	x	SIXTEENTH_OFFSET_Q is a 5-bit twos complement number in 16ths of an LSB that is added to incoming Q data. x/16 LSB DC offset.	0x0	R/W
0x13C	IDAC_DIG_GAIN0	[7:0]	IDAC_DIG_GAIN[7:0]		LSB of I DAC digital gain.	0x0	R/W
0x13D	IDAC_DIG_GAIN1	[7:4]	RESERVED		Reserved.	0x0	R/W
		[3:0]	IDAC_DIG_GAIN[11:8]		4 MSBs of I DAC digital gain.	0x8	R/W
0x13E	QDAC_DIG_GAIN0	[7:0]	QDAC_DIG_GAIN[7:0]		8 LSBs of Q DAC digital gain. QDAC_DIG_GAIN is the digital gain of the Q DAC. The digital gain is a multiplier from 0 to 4095/2048 in steps of 1/2048.	0x0	R/W
0x13F	QDAC_DIG_GAIN1	[7:4]	RESERVED		Reserved.	0x0	R/W
		[3:0]	QDAC_DIG_GAIN[11:8]		4 MSBs of Q DAC digital gain.	0x8	R/W
0x140	GAIN_RAMP_UP_STEP0	[7:0]	GAIN_RAMP_UP_STEP[7:0]	0x0 0xFFFF	8 LSBs of gain ramp up step. GAIN_RAMP_UP_STEP controls the amplitude step size of the BSMs ramping feature when the gain is being ramped to its assigned value. Smallest ramp up step size. Largest ramp up step size.	0x4	R/W
0x141	GAIN_RAMP_UP_STEP1	[7:4]	RESERVED		Reserved.	0x0	R/W
		[3:0]	GAIN_RAMP_UP_STEP[11:8]		4 MSBs of gain ramp up step. See Register 0x140 for description.	0x0	R/W
0x142	GAIN_RAMP_DOWN_STEP0	[7:0]	GAIN_RAMP_DOWN_STEP[7:0]	0 0xFFFF	8 LSBs of gain ramp down step. GAIN_RAMP_DOWN_STEP controls the amplitude step size of the BSMs ramping feature when the gain is being ramped to zero. Smallest ramp down step size. Largest ramp down step size.	0x9	R/W
0x143	GAIN_RAMP_DOWN_STEP1	[7:4]	RESERVED		Reserved.	0x0	R/W
		[3:0]	GAIN_RAMP_DOWN_STEP[7:0]		MSB of digital gain drops	0x0	R/W
0x14B	PRBS	7	PRBS_GOOD_Q	0 1	Good data indicator imaginary channel. Incorrect sequence detected. Correct PRBS sequence detected.	0x0	R
		6	PRBS_GOOD_I	0 1	Good data indicator real channel. Incorrect sequence detected. Correct PRBS sequence detected.	0x0	R
		5	RESERVED		Reserved.	0x0	R/W
		4	PRBS_INV_Q	0 1	Data inversion imaginary channel. Expect normal data. Expect inverted data.	0x1	R/W
		3	PRBS_INV_I	0 1	Data inversion real channel. Expect normal data. Expect inverted data.	0x0	R/W
		2	PRBS_MODE	0 1	Polynomial select. 7-bit: $x^7 + x^6 + 1$ . 15-bit: $x^{15} + x^{14} + 1$ .	0x0	R/W
		1	PRBS_RESET	0 1	Reset error counters. Normal operation. Reset counters.	0x0	R/W
		0	PRBS_EN	0 1	Enable PRBS checker. Disable Enable	0x0	R/W
0x14C	PRBS_ERROR_I	[7:0]	PRBS_COUNT_I		Error count value real channel.	0x0	R
0x14D	PRBS_ERROR_Q	[7:0]	PRBS_COUNT_Q		Error count value imaginary channel.	0x0	R

Addr.	Name	Bits	Bit Name	Settings	Description	Reset	Access
0x151	DATAPATH_CTRL2	[7:6]	RESERVED		Reserved.	0x0	R/W
		5	PFIR_DEMOD4_ENABLE		Programmable FIR demodulation enable.	0x0	R/W
		4	PFIR_ENABLE		Programmable FIR enable.	0x0	R/W
		[3:2]	RESERVED		Reserved.	0x0	R/W
		1	NEG_DDS_FREQ		Negative DDS frequency.	0x0	R/W
0	MODULUS_ENABLE		Modulus enable.	0x0	R/W		
0x152	ACC_MODULUS0	[7:0]	ACC_MODULUS[7:0]		Tuning Word B for modulus DDS.	0x0	R/W
0x153	ACC_MODULUS1	[7:0]	ACC_MODULUS[15:8]		Tuning Word B for modulus DDS.	0x0	R/W
0x154	ACC_MODULUS2	[7:0]	ACC_MODULUS[23:16]		Tuning Word B for modulus DDS.	0x0	R/W
0x155	ACC_MODULUS3	[7:0]	ACC_MODULUS[31:24]		Tuning Word B for modulus DDS.	0x0	R/W
0x156	ACC_MODULUS4	[7:0]	ACC_MODULUS[39:32]		Tuning Word B for modulus DDS.	0x0	R/W
0x157	ACC_MODULUS5	[7:0]	ACC_MODULUS[47:40]		Tuning Word B for modulus DDS.	0x0	R/W
0x158	ACC_DELTA0	[7:0]	ACC_DELTA[7:0]		Tuning Word A for modulus DDS.	0x0	R/W
0x159	ACC_DELTA1	[7:0]	ACC_DELTA[15:8]		Tuning Word A for modulus DDS.	0x0	R/W
0x15A	ACC_DELTA2	[7:0]	ACC_DELTA[23:16]		Tuning Word A for modulus DDS.	0x0	R/W
0x15B	ACC_DELTA3	[7:0]	ACC_DELTA[31:24]		Tuning Word A for modulus DDS.	0x0	R/W
0x15C	ACC_DELTA4	[7:0]	ACC_DELTA[39:32]		Tuning Word A for modulus DDS.	0x0	R/W
0x15D	ACC_DELTA5	[7:0]	ACC_DELTA[47:40]		Tuning Word A for modulus DDS.	0x0	R/W
0x17A	PFIR_COEFF0_L	[7:0]	PFIR_COEFF0[7:0]		PFIR Coefficient 0, Bits[7:0].	0x0	R/W
0x17B	PFIR_COEFF0_H	[7:1]	RESERVED		Reserved.	0x0	R/W
		0	PFIR_COEFF0[8]		PFIR Coefficient 0, Bit 8.	0x0	R/W
0x17C	PFIR_COEFF1_L	[7:0]	PFIR_COEFF1[7:0]		PFIR Coefficient 1, Bits[7:0].	0x0	R/W
0x17D	PFIR_COEFF1_H	[7:1]	RESERVED		Reserved.	0x0	R/W
		0	PFIR_COEFF1[8]		PFIR Coefficient 1, Bit 8.	0x0	R/W
0x17E	PFIR_COEFF2_L	[7:0]	PFIR_COEFF2[7:0]		PFIR Coefficient 0, Bits[7:0].	0x0	R/W
0x17F	PFIR_COEFF2_H	[7:1]	RESERVED		Reserved.	0x0	R/W
		0	PFIR_COEFF2[8]		PFIR Coefficient 1, Bit 8.	0x0	R/W
0x180	PFIR_COEFF3_L	[7:0]	PFIR_COEFF3[7:0]		PFIR Coefficient 0, Bits[7:0].	0x0	R/W
0x181	PFIR_COEFF3_H	[7:1]	RESERVED		Reserved.	0x0	R/W
		0	PFIR_COEFF3[8]		PFIR Coefficient 1, Bit 8.	0x0	R/W
0x182	PFIR_COEFF_UPDATE	[7:1]	RESERVED		Reserved.	0x0	R/W
		0	PFIR_COEFF_UPDATE		PFIR coefficient update.	0x0	R/W
0x1B4	DACPLLT4	7	BYP_LOAD_DELAY		Bypass load delay.	0x0	R/W
		[6:3]	VCO_CAL_OFFSET		Starting offset for VCO calibration	0xF	R/W
		2	RESERVED		Reserved.	0x0	R/W
		1	EXT_BAND_EN	0 1	Force VCO tuning band externally Normal auto calibration mode. Manual for VCO band.	0x0	R/W
		0	EXT_BAND2		External band MSB.	0x0	W
0x1B5	DACPLLT5	[7:4]	INIT_ALC_VALUE		Initial ALC sweep value.	0x8	R/W
		[3:0]	VCO_VAR		Varactor KVO setting.	0x3	R/W
0x1B6	DACPLLT6	7	RESERVED		Reserved.	0x0	R/W
		6	PORESETB_VCO		RESET for VCO logic.	0x1	R/W
		[5:4]	EXT_VCO_BITSEL		Bit select; Does nothing.	0x0	R/W
		[3:0]	VCO_LVL_OUT		VCO amplitude control.	0xA	R/W
0x1BB	DACPLLTB	[7:5]	RESERVED		Reserved.	0x0	R/W
		[4:3]	VCO_BIAS_TCF		Temperature coefficient for VCO bias.	0x1	R/W
		[2:0]	VCO_BIAS_REF		VCO Bias control	0x4	R/W
0x1C5	DACPLLT18	[7:4]	RESERVED		Reserved.	0x0	R/W
		[3:0]	VCO_VAR_REF		VCO varactor reference	0x8	R/W
0x1FE	TEST_MODE	[7:3]	RESERVED		Reserved.	0x0	R
		[2:0]	TSTWINDOW		Sync error window. Sync alignment tolerance in $\pm$ DACCLKs.	0x0	R/W
0x200	MASTER_PD	[7:1]	RESERVED		Reserved.	0x0	R/W
		0	SPI_PD_MASTER		Power down the entire JESD204B receiver analog	0x1	R/W

Addr.	Name	Bits	Bit Name	Settings	Description	Reset	Access
0x201	PHY_PD	[7:4]	RESERVED		(all four channels plus bias). Reserved.	0x0	R/W
		[3:0]	SPI_PD_PHY		SPI override to power down the individual PHYs. Set Bit x to power down the corresponding SERDIN <sub>x±</sub> PHY	0x0	R/W
0x203	GENERIC_PD	[7:2]	RESERVED		Reserved.	0x0	R/W
		1	SPI_SYNC_PD		Power down LVDS buffer for SYNCOUT <sub>±</sub> .	0x0	R/W
		0	RESERVED		Reserved.	0x0	R/W
0x206	CDR_RESET	[7:1]	RESERVED		Reserved.	0x0	R/W
		0	SPI_CDR_RESETN	0 1	Resets the digital control logic for all PHYs. Hold CDR in reset Enable CDR	0x1	R/W
0x230	CDR_OPERATING_MODE_REG_0	[7:6]	RESERVED		Reserved.	0x0	R/W
		5	ENHALFRATE		Enables half-rate CDR operation. Set to 1 when 5.75 Gbps ≤ lane rate ≤ 12.38 Gbps.	0x1	R/W
		[4:2]	RESERVED		Must write the default value for proper operation.	0x2	R/W
		1	CDR_OVERSAMP		Enables oversampling of the input data. Set to 1 when 1.44 Gbps ≤ lane rate ≤ 3.09 Gbps.	0x0	R/W
		0	SYNCOUTB_SWING	0 1	This bit is to adjust SYNCOUT <sub>±</sub> LVDS output swing. SYNCOUT <sub>±</sub> swing VOD is about 170 mV. SYNCOUT <sub>±</sub> swing VOD is about 350 mV.	0x0	R/W
0x268	EQ_BIAS_REG	[7:6]	EQ_POWER_MODE	00 01	Control the equalizer power/insertion loss capability. Normal mode. Low power mode.	0x1	R/W
		[5:0]	RESERVED		Reserved. Must write the default value for proper operation.	0x22	R/W
0x280	SERDESPLL_ENABLE_CNTRL	[7:3]	RESERVED		Reserved.	0x0	R/W
		2	RECAL_SERDESPLL		Recalibrate SERDES PLL. On a rising edge, recalibrate the SERDES PLL.	0x0	R/W
		1	RESERVED		Reserved.	0x0	R/W
		0	ENABLE_SERDESPLL		Enable the SERDES PLL. Setting this bit enables and calibrates the SERDES PLL.	0x0	R/W
0x281	SERDES_PLL_STATUS	[7:6]	RESERVED		Reserved.	0x0	R
		5	SERDES_CP_OVER_RANGE_H		Charge pump high overrange. This bit indicates that the SERDES PLL hit the lower edge of its operating band. Recalibrate.	0x0	R
		4	SERDES_CP_OVER_RANGE_L		Charge pump low overrange. This bit indicates that the SERDES PLL hit the lower edge of its operating band. Recalibrate.	0x0	R
		3	SERDES_PLL_CAL_VALID		SERDES PLL calibration valid. This bit indicates that the SERDES PLL has been successfully calibrated.	0x0	R
		2	SERDES_VCO_CAL_PROGRESS	0 1	This bit set indicates that a VCO calibration is running. VCO calibration is not running. VCO calibration is running.	0x0	R
		1	SERDES_PLL_CURRENTS_READY	0 1	PLL bias currents are not ready PLL bias currents are ready	0x0	R
		0	SERDES_PLL_LOCK		SERDES PLL lock. This bit is set high by the PLL when it has achieved lock.	0x0	R
0x289	REF_CLK_DIVIDER_LDO	[7:2]	RESERVED		Must be set to 1 for proper SERDES PLL configuration.	0x1	R/W
		[1:0]	SERDES_PLL_DIV_MODE	00	SERDES PLL reference clock division factor. This field controls the division of the SERDES PLL reference clock before it is fed into the SERDES PLL phase frequency detector (PFD). It must be set so f <sub>REF</sub> /DivFactor is between 35 MHz and 80 MHz. Divide by 4 for 5.75 Gbps to 12.38 Gbps lane rate	0x0	R/W

Addr.	Name	Bits	Bit Name	Settings	Description	Reset	Access
				01 10	Divide by 2 for 2.88 Gbps to 6.19 Gbps lane rate Divide by 1 for 1.44 Gbps to 3.09 Gbps lane rate		
0x2A7	TERM_BLK1_CTRLREG0	[7:1]	RESERVED		Reserved.	0x0	R
		0	SPI_I_TUNE_R_CAL_TERMBLK1		Termination calibration. The rising edge of this bit calibrates PHY terminations to 50 Ω.	0x0	R/W
0x300	GENERAL_JRX_CTRL_0	7	RESERVED		Reserved.	0x0	R
		6	CHECKSUM_MODE		Checksum mode. This bit controls the locally generated JESD204B link parameter checksum method. The value is stored in the FCMP registers (Register 0x40E, Register 0x416, Register 0x41E, and Register 0x426).  0 Checksum is calculated by summing the individual fields in the link configuration table as defined in Section 8.3, Table 20 of the JESD204B standard. 1 Checksum is calculated by summing the registers containing the packed link configuration fields ( $\Sigma[0x450:0x45C]$ modulo 256).	0x0	R/W
		[5:1]	RESERVED		Reserved.	0x0	R
		0	LINK_EN		Link enable. Enable the link only after the following has occurred: all JESD204B parameters are set, the DAC PLL is enabled and locked (Register 0x084[1] = 1), and the JESD204B PHY is enabled (Register 0x200 = 0x00) and calibrated (Register 0x281[2] = 0).	0x0	R/W
0x301	GENERAL_JRX_CTRL_1	[7:3]	RESERVED		Reserved.	0x0	R/W
		[2:0]	SUBCLASSV_LOCAL	000 001	JESD204B Subclass. Subclass 0. Subclass 1.	0x1	R/W
0x302	DYN_LINK_LATENCY_0	[7:5]	RESERVED		Reserved.	0x0	R/W
		[4:0]	DYN_LINK_LATENCY_0		Dynamic link latency: Link 0. Latency between the LMFC <sub>Rx</sub> for Link 0 and the last arriving LMFC boundary in units of PCLK cycles. See the Deterministic Latency section.	0x0	R
0x304	LMFC_DELAY_0	[7:5]	RESERVED		Reserved.	0x0	R/W
		[4:0]	LMFC_DELAY_0		LMFC delay: Link 0 Delay from the LMFC to LMFC <sub>Rx</sub> for Link 0. In units of frame clock cycles for subclass 1 and PCLK cycles for subclass 0. See the Deterministic Latency section.	0x0	R/W
0x306	LMFC_VAR_0	[7:5]	RESERVED		Reserved.	0x0	R/W
		[4:0]	LMFC_VAR_0		Variable delay buffer: Link 0. Sets when data is read from a buffer to be consistent across links and power cycles. In units of PCLK cycles. See the Deterministic Latency section. This setting must not be more than 10.	0x6	R/W
0x308	XBAR_LN_0_1	[7:6]	RESERVED		Reserved.	0x0	R/W
		[5:3]	LOGICAL_LANE1_SRC	x	Logical Lane 1 source. Selects a physical lane to be mapped onto Logical Lane 1. Data is from SERDINx.	0x1	R/W
		[2:0]	LOGICAL_LANE0_SRC	x	Logical Lane 0 source. Selects a physical lane to be mapped onto Logical Lane 0. Data is from SERDINx.	0x0	R/W
0x309	XBAR_LN_2_3	[7:6]	RESERVED		Reserved.	0x0	R/W
		[5:3]	LOGICAL_LANE3_SRC	x	Logical Lane 3 source. Selects a physical lane to be mapped onto Logical Lane 3. Data is from SERDINx.	0x3	R/W
		[2:0]	LOGICAL_LANE2_SRC	x	Logical Lane 2 source. Selects a physical lane to be mapped onto Logical Lane 2. Data is from SERDINx.	0x2	R/W
0x30C	FIFO_STATUS_REG_0	[7:4]	RESERVED		Reserved.	0x0	R
		[3:0]	LANE_FIFO_FULL		FIFO full flags for each logical lane. A full FIFO indicates an error in the JESD204B configuration or with a system clock. If the FIFO for Lane x is full, Bit x in this register is high.	0x0	R

Addr.	Name	Bits	Bit Name	Settings	Description	Reset	Access
0x30D	FIFO_STATUS_REG_1	[7:4]	RESERVED		Reserved.	0x0	R
		[3:0]	LANE_FIFO_EMPTY		FIFO empty flags for each logical lane. An empty FIFO indicates an error in the JESD204B configuration or with a system clock. If the FIFO for Logical Lane x is empty, Bit x in this register is high.	0x0	R
0x311	SYNCB_GEN_0	[7:4]	RESERVED		Reserved.	0x0	R/W
		3	RESERVED		Reserved.	0x0	R/W
		2	EOMF_MASK_0	0	Mask EOMF from QBD. Assert SYNCOUT± based on loss of multiframe sync. Do not assert SYNCOUT± on Loss of multiframe.	0x0	R/W
				1	Assert SYNCOUT± on loss of multiframe.	0x0	R/W
		1	RESERVED		Reserved.	0x0	R/W
0	EOF_MASK_0		Mask EOF from QBD. Assert SYNCOUT± based on loss of frame sync. Do not assert SYNCOUT± on loss of frame. Assert SYNCOUT± on loss of frame.	0x0	R/W		
0x312	SYNCB_GEN_1	[7:4]	SYNCB_ERR_DUR		Duration of SYNCOUT± low for error. A sync error is asserted at the end of a multiframe whenever one or more disparity, not in table, or unexpected control character errors are encountered. 0 ½ PCLK cycle. 1 1 PCLK cycle. 2 2 PCLK cycles.	0x0	R/W
		[3:0]	SYNCB_SYNCREQ_DUR		Duration of SYNCOUT± low for purpose of sync request. 0 means a duration > 5 frame + 9 octets. Add an additional PCLK = 4 octets for each increment of the value.	0x0	R/W
0x313	SYNCB_GEN_3	[7:0]	LMFC_PERIOD		LMFC period in PCLK cycle. This is to report the global LMFC period based on PCLK.	0x0	R
0x314	SERDES_SPI_REG	[7:0]	SERDES_SPI_CONFIG		SERDES SPI configuration. Must be written to 0x01 as part of the physical layer setup step.	0x0	R/W
0x315	PHY_PRBS_TEST_EN	[7:4]	RESERVED		Reserved.	0x0	R/W
		[3:0]	PHY_TEST_EN		PHY test enable. Enables the PHY BER test. Set Bit x to enable the PHY test for Lane x.	0x0	R/W
0x316	PHY_PRBS_TEST_CTRL	7	RESERVED		Reserved.	0x0	R/W
		[6:4]	PHY_SRC_ERR_CNT		PHY error count source. Selects which PHY errors are being reported in Register 0x31A to Register 0x31C. x Report Lane x error count.	0x0	R/W
		[3:2]	PHY_PRBS_PAT_SEL		PHY PRBS pattern select. Selects the PRBS pattern for the PHY BER test. 00 PRBS7. 01 PRBS15. 10 PRBS31. 11 Reserved.	0x0	R/W
		1	PHY_TEST_START		PHY PRBS test start. Starts and stops the PHY PRBS test. 0 Test stopped. 1 Test in progress.	0x0	R/W
		0	PHY_TEST_RESET		PHY PRBS test reset. Resets the PHY PRBS test state machine and error counters. 0 Enable PHY PRBS test state machine. 1 Hold PHY PRBS test state machine in reset.	0x0	R/W
0x317	PHY_PRBS_TEST_THRESHOLD_LOBITS	[7:0]	PHY_PRBS_THRESHOLD[7:0]		Bits[7:0] of the 24-bit threshold value to set the error flag for the PHY PRBS test.	0x0	R/W
0x318	PHY_PRBS_TEST_THRESHOLD_MIDBITS	[7:0]	PHY_PRBS_THRESHOLD[15:8]		Bits[15:8] of the 24-bit threshold value to set the error flag for the PHY PRBS test.	0x0	R/W
0x319	PHY_PRBS_TEST_THRESHOLD_HIBITS	[7:0]	PHY_PRBS_THRESHOLD[23:16]		Bits[23:16] of the 24-bit threshold value to set the error flag for the PHY PRBS test.	0x0	R/W
0x31A	PHY_PRBS_TEST_	[7:0]	PHY_PRBS_ERR_CNT[7:0]		Bits[7:0] of the 24-bit reported PHY BERT error	0x0	R

Addr.	Name	Bits	Bit Name	Settings	Description	Reset	Access
	ERRCNT_LOBITS				count from the selected lane.		
0x31B	PHY_PRBS_TEST_ERRCNT_MIDBITS	[7:0]	PHY_PRBS_ERR_CNT[15:8]		Bits[15:8] of the 24-bit reported PHY BERT error count from the selected lane.	0x0	R
0x31C	PHY_PRBS_TEST_ERRCNT_HIBITS	[7:0]	PHY_PRBS_ERR_CNT[23:16]		Bits[23:16] of the 24-bit reported PHY BERT error count from the selected lane.	0x0	R
0x31D	PHY_PRBS_TEST_STATUS	[7:4]	RESERVED		Reserved.	0x0	R
		[3:0]	PHY_PRBS_PASS		PHY PRBS test pass/fail. Bit x corresponds to PHY PRBS pass/fail for Physical Lane x. The bit is set to 1 while the error count for Physical Lane x is less than PHY_PRBS_THRESHOLD.	0xF	R
0x32C	SHORT_TPL_TEST_0	[7:6]	RESERVED		Reserved.	0x0	R/W
		[5:4]	SHORT_TPL_SP_SEL		Short transport layer sample select. Selects which sample to check from the DAC selected via Bits[3:2]. Sample x.	0x0	R/W
		[3:2]	SHORT_TPL_DAC_SEL		Short transport layer test DAC select. Selects which DAC to sample. Sample from DAC x.	0x0	R/W
		1	SHORT_TPL_TEST_RESET		Short transport layer test reset. Resets the result of short transport layer test. 0 Not reset. 1 Reset.	0x0	R/W
		0	SHORT_TPL_TEST_EN		Short transport layer test enable. See the Subclass 0 section for details on how to perform this test. 0 Disable. 1 Enable.	0x0	R/W
0x32D	SHORT_TPL_TEST_1	[7:0]	SHORT_TPL_REF_SP_LSB		Short transport layer test reference, sample LSB. This is the lower eight bits of the expected DAC sample. It is used to compare with the received DAC sample at the output of the JESD204B receiver.	0x0	R/W
0x32E	SHORT_TPL_TEST_2	[7:0]	SHORT_TPL_REF_SP_MSB		Short transport layer test reference, sample MSB. This is the upper eight bits of the expected DAC sample. It is used to compare with the received DAC sample at the output of the JESD204B receiver.	0x0	R/W
0x32F	SHORT_TPL_TEST_3	[7:1]	RESERVED		Reserved.	0x0	R
		0	SHORT_TPL_FAIL		Short transport layer test fail. This bit shows whether the selected DAC sample matches the reference sample. If they match, it is a test pass, otherwise it is a test fail. 0 Test pass. 1 Test fail.	0x0	R
0x334	JESD_BIT_INVERSE_CTRL	[7:4]	RESERVED		Reserved.	0x0	R/W
		[3:0]	JESD_BIT_INVERSE		Logical lane invert. Set Bit x high to invert the JESD204B deserialized data on Logical Lane x.	0x0	R/W
0x400	DID_REG	[7:0]	DID_RD		Device identification number. Link information received on Lane 0 as specified in Section 8.3 of JESD204B.	0x0	R
0x401	BID_REG	[7:4]	ADJCNT_RD		Adjustment resolution to DAC LMFC. Link information received on Lane 0 as specified in Section 8.3 of JESD204B.	0x0	R
		[3:0]	BID_RD		Bank identification: extension to DID. Link information received on Lane 0 as specified in Section 8.3 of JESD204B.	0x0	R
0x402	LID0_REG	7	RESERVED		Reserved.	0x0	R
		6	ADJDIR_RD		Direction to adjust DAC LMFC. Link information received on Lane 0 as specified in Section 8.3 of JESD204B. Must be 0.	0x0	R
		5	PHADJ_RD		Phase adjustment request to DAC. Link information received on Lane 0 as specified in Section 8.3 of JESD204B. Must be 0.	0x0	R

Addr.	Name	Bits	Bit Name	Settings	Description	Reset	Access
		[4:0]	LIDO_RD		Lane identification for Lane 0. Link information received on Lane 0 as specified in Section 8.3 of JESD204B.	0x0	R
0x403	SCR_L_REG	7	SCR_RD	0 1	Transmit scrambling status. Link information received on Lane 0 as specified in Section 8.3 of JESD204B. 0 Scrambling is disabled. 1 Scrambling is enabled.	0x0	R
		[6:5]	RESERVED		Reserved.	0x0	R
		[4:0]	L-1_RD	0 1	Number of lanes per converter device. Link information received on Lane 0 as specified in Section 8.3 of JESD204B. 0 One lane per converter device. 1 Two lanes per converter device.	0x0	R
0x404	F_REG	[7:0]	F-1_RD	0 1 3	Number of octets per frame. Settings of 1, 2, and 4 octets per frame are valid. Link information received on Lane 0 as specified in Section 8.3 of JESD204B. 0 One octet per frame. 1 Two octets per frame. 3 Four octets per frame.	0x0	R
0x405	K_REG	[7:5]	RESERVED		Reserved.	0x0	R
		[4:0]	K-1_RD	0x0F 0x1F	Number of frames per multiframe. Settings of 16 or 32 are valid. Link information received on Lane 0 as specified in Section 8.3 of JESD204B. 0x0F 16 frames per multiframe. 0x1F 32 frames per multiframe.	0x0	R
0x406	M_REG	[7:0]	M-1_RD	0 1	Number of converters per device. Link information received on Lane 0 as specified in Section 8.3 of JESD204B. Must be 0 or 1. 0 One converter per device. 1 Two converters per device.	0x0	R
0x407	CS_N_REG	[7:6]	CS_RD		Number of control bits per sample. Link information received on Lane 0 as specified in Section 8.3 of JESD204B. CS_RD must be set to 0.	0x0	R
		5	RESERVED		Reserved.	0x0	R
		[4:0]	N-1_RD	0x0F	Converter resolution. Link information received on Lane 0 as specified in Section 8.3 of JESD204B. Converter resolution of 16. 0x0F Converter resolution of 16.	0x0	R
0x408	NP_REG	[7:5]	SUBCLASSV_RD	0 1	Device subclass version. Link information received on Lane 0 as specified in Section 8.3 of JESD204B. 0 Subclass 0. 1 Subclass 1.	0x0	R
		[4:0]	NP-1_RD	0x0F	Total number of bits per sample. Link information received on Lane 0 as specified in Section 8.3 of JESD204B. Must be 16 bits per sample. 0x0F 16 bits per sample.	0x0	R
0x409	S_REG	[7:5]	JESDV_RD	000 001	JESD204 version. Link information received on Lane 0 as specified in Section 8.3 of JESD204B. 000 JESD204A. 001 JESD204B.	0x0	R
		[4:0]	S-1_RD	0 1	Number of samples per converter per frame cycle. Settings of one and two are valid. See Table 33. Link information received on Lane 0 as specified in Section 8.3 of JESD204B. 0 One sample per converter per frame. 1 Two samples per converter per frame.	0x0	R
0x40A	HD_CF_REG	7	HD_RD	0 1	High density format. See Section 5.1.3 of the JESD294B standard. Link information received on Lane 0 as specified in Section 8.3 of JESD204B. 0 Low density mode. 1 High density mode: link information received on Lane 0 as specified in Section 8.3 of JESD204B.	0x0	R
		[6:5]	RESERVED		Reserved.	0x0	R

Addr.	Name	Bits	Bit Name	Settings	Description	Reset	Access
		[4:0]	CF_RD		Number of control words per frame clock period per link. Link information received on Lane 0 as specified in Section 8.3 of JESD204B. Bits[4:0] must be 0.	0x0	R
0x40B	RES1_REG	[7:0]	RES1_RD		Reserved Field 1. Link information received on Lane 0 as specified in Section 8.3 of JESD204B.	0x0	R
0x40C	RES2_REG	[7:0]	RES2_RD		Reserved Field 2. Link information received on Lane 0 as specified in Section 8.3 of JESD204B.	0x0	R
0x40D	CHECKSUM_REG	[7:0]	FCHK0_RD		Checksum for Lane 0. Link information received on Lane 0 as specified in Section 8.3 of JESD204B.	0x0	R
0x40E	COMPSUM0_REG	[7:0]	FCMP0_RD		Computed checksum for Lane 0. The JESD204B receiver computes the checksum of the link information received on Lane 0 as specified in Section 8.3 of JESD204B. The computation method is set by the CHECKSUM_MODE bit (Address 0x300[6]) and must match the likewise calculated checksum in Register 0x40D.	0x0	R
0x412	LID1_REG	[7:5]	RESERVED		Reserved.	0x0	R
		[4:0]	LID1_RD		Lane identification for Lane 1. Link information received on Lane 0 as specified in Section 8.3 of JESD204B.	0x0	R
0x415	CHECKSUM1_REG	[7:0]	FCHK1_RD		Checksum for Lane 1. Link information received on Lane 0 as specified in Section 8.3 of JESD204B.	0x0	R
0x416	COMPSUM1_REG	[7:0]	FCMP1_RD		Computed checksum for Lane 1. See the description for Register 0x40E.	0x0	R
0x41A	LID2_REG	[7:5]	RESERVED		Reserved.	0x0	R
		[4:0]	LID2_RD		Lane identification for Lane 2.	0x0	R
0x41D	CHECKSUM2_REG	[7:0]	FCHK2_RD		Checksum for Lane 2.	0x0	R
0x41E	COMPSUM2_REG	[7:0]	FCMP2_RD		Computed checksum for Lane 2 (see the description for Register 0x40E).	0x0	R
0x422	LID3_REG	[7:5]	RESERVED		Reserved.	0x0	R
		[4:0]	LID3_RD		Lane identification for Lane 3.	0x0	R
0x425	CHECKSUM3_REG	[7:0]	FCHK3_RD		Checksum for Lane 3.	0x0	R
0x426	COMPSUM3_REG	[7:0]	FCMP3_RD		Computed checksum for Lane 3 (see the description for Register 0x40E).	0x0	R
0x450	ILS_DID	[7:0]	DID		Device identification number. Link information received on Lane 0 as specified in Section 8.3 of JESD204B. Must be set to the value read in Register 0x400.	0x0	R/W
0x451	ILS_BID	[7:4]	ADJCNT		Adjustment resolution to DAC LMFC. Must be set to 0.	0x0	R/W
		[3:0]	BID		Bank identification: extension to DID. Must be set to the value read in Register 0x401[3:0].	0x0	R/W
0x452	ILS_LID0	7	RESERVED		Reserved.	0x0	R/W
		6	ADJDIR		Direction to adjust DAC LMFC. Must be set to 0.	0x0	R/W
		5	PHADJ		Phase adjustment request to DAC. Must be set to 0.	0x0	R/W
		[4:0]	LID0		Lane identification for Lane 0. Must be set to the value read in Register 0x402[4:0].	0x0	R/W
0x453	ILS_SCR_L	7	SCR	0	Receiver descrambling enable.	0x1	R/W
				1	Descrambling is disabled.		
		[6:5]	RESERVED		Reserved.	0x0	R/W
0x454	ILS_F	[4:0]	L-1		Number of lanes per converter device. See Table 33.	0x3	R/W
				0	One lane per converter.		
				1	Two lanes per converter.		
				3	Four octets per lane per frame.		

Addr.	Name	Bits	Bit Name	Settings	Description	Reset	Access
0x455	ILS_K	[7:5]	RESERVED		Reserved.	0x0	R/W
		[4:0]	K-1	0x0F 0x1F	Number of frames per multiframe. Settings of 16 or 32 are valid. Must be set to 32 when F = 1 (Register 0x476). 16 frames per multiframe. 32 frames per multiframe.	0x1F	R/W
0x456	ILS_M	[7:0]	M-1	0 1	Number of converters per device. See Table 33. One converter per link. Two converters per link.	0x1	R/W
0x457	ILS_CS_N	[7:6]	CS	0	Number of control bits per sample. Must be set to 0. Control bits are not supported. Zero control bits per sample.	0x0	R/W
		5	RESERVED		Reserved.	0x0	R/W
		[4:0]	N-1	0xF	Converter Resolution. Must be set to 16 bits of resolution. Converter resolution of 16.	0xF	R/W
0x458	ILS_NP	[7:5]	SUBCLASSV	0 1	Device subclass version. Subclass 0. Subclass 1.	0x1	R/W
		[4:0]	NP-1	0xF	Total number of bits per sample. Must be set to 16 bits per sample. 16 bits per sample.	0xF	R/W
0x459	ILS_S	[7:5]	JESDV	000 001	JESD204 version. JESD204A. JESD204B.	0x1	R/W
		[4:0]	S-1	0 1	Number of samples per converter per frame cycle. Settings of one and two are valid. See Table 33. One sample per converter per frame. Two samples per converter per frame.	0x0	R/W
0x45A	ILS_HD_CF	7	HD	0 1	High density format. If F = 1, HD must be set to 1. Otherwise, HD must be set to 0. See Section 5.1.3 of JESD204B standard. Low density mode. High density mode.	0x1	R/W
		[6:5]	RESERVED		Reserved.	0x0	R/W
		[4:0]	CF		Number of control words per frame clock period per link. Must be set to 0. Control bits are not supported.	0x0	R/W
0x45B	ILS_RES1	[7:0]	RES1		Reserved Field 1.	0x0	R/W
0x45C	ILS_RES2	[7:0]	RES2		Reserved Field 2.	0x0	R/W
0x45D	ILS_CHECKSUM	[7:0]	FCHK0		Checksum for Lane 0. Calculated checksum. Calculation depends on 0x300[6].	0x45	R/W
0x46B	ERRCNTRMON_RB	[7:0]	READERRORCNTR		Read JESD204B error counter. After selecting the lane and error counter by writing to LANESEL and CNTRSEL (both in this same register), the selected error counter is read back here.	0x0	R
0x46B	ERRCNTRMON	7	RESERVED		Reserved.	0x0	R
		[6:4]	LANESEL	x	Lane select for JESD204B error counter. Selects the lane whose errors are read back in this register. Selects Lane x.	0x0	W
		[3:2]	RESERVED		Reserved.	0x0	R
		[1:0]	CNTRSEL	00 01 10	JESD204B error counter select. Selects the type of error that are read back in this register. BADDISCNTR: bad running disparity counter. NITCNTR: not in table error counter. UCCCNTR: Unexpected control character counter.	0x0	W
0x46C	LANEDESKEW	[7:0]	LANEDESKEW		Lane deskew. Setting Bit x deskews Lane x.	0xF	R/W
0x46D	BADDISPARITY_RB	[7:0]	BADDIS		Bad disparity character error (BADDIS). Bit x is set when the bad disparity error count for Lane x reaches the threshold in Register 0x47C.	0x0	R
0x46D	BADDISPARITY	7	RST_IRQ_DIS		BADDIS IRQ reset. Reset BADDIS IRQ for the lane selected via Bits[2:0] by writing 1 to this bit.	0x0	W

Addr.	Name	Bits	Bit Name	Settings	Description	Reset	Access
		6	DISABLE_ERR_CNTR_DIS		BADDIS error counter disable. Disable the BADDIS error counter for the lane selected via Bits[2:0] by writing 1 to this bit.	0x0	W
		5	RST_ERR_CNTR_DIS		BADDIS error counter reset. Reset the BADDIS error counter for the lane selected via Bits[2:0] by writing 1 to this bit.	0x0	W
		[4:3]	RESERVED		Reserved.	0x0	R
		[2:0]	LANE_ADDR_DIS		Lane address for functions described in Bits[7:5].	0x0	W
0x46E	NIT_RB	[7:0]	NIT		Not in table character error (NIT). Bit x is set when the NIT error count for Lane x reaches the threshold in Register 0x47C.	0x0	R
0x46E	NIT_W	7	RST_IRQ_NIT		IRQ reset. Reset the IRQ for the lane selected via Bits[2:0] by writing 1 to this bit.	0x0	W
		6	DISABLE_ERR_CNTR_NIT		Disable error counter. Disable the error counter for the lane selected via Bits[2:0] by writing 1 to this bit.	0x0	W
		5	RST_ERR_CNTR_NIT		Reset error counter. Reset error counter for the lane selected via Bits[2:0] by writing 1 to this bit.	0x0	W
		[4:3]	RESERVED		Reserved.	0x0	R
		[2:0]	LANE_ADDR_NIT		Lane address for functions described in Bits[7:5].	0x0	W
0x46F	UNEXPECTED_CONTROL_RB	[7:0]	UCC		Unexpected control character error (UCC). Bit x is set when the UCC error count for Lane x reaches the threshold in Register 0x47C.	0x0	R
0x46F	UNEXPECTED_CONTROL_W	7	RST_IRQ_UCC		IRQ reset. Reset IRQ for the lane selected via Bits[2:0] by writing 1 to this bit.	0x0	W
		6	DISABLE_ERR_CNTR_UCC		Disable error counter. Disable the error counter for the lane selected via Bits[2:0] by writing 1 to this bit.	0x0	W
		5	RST_ERR_CNTR_UCC		Reset error counter. Reset error counter for the lane selected via Bits[2:0] by writing 1 to this bit.	0x0	W
		[4:3]	RESERVED		Reserved.	0x0	R
		[2:0]	LANE_ADDR_UCC		Lane Address for functions described in Bits[7:5].	0x0	W
0x470	CODEGRPSYNCFLG	[7:0]	CODEGRPSYNC		Code group sync flag (from each instantiated lane). Writing 1 to Bit 7 resets the IRQ. The associated IRQ flag is located in Register 0x47A[0]. A loss of CODEGRPSYNC triggers sync request assertion. See the SYNCOUT and SYSREF Signals section and the Deterministic Latency section. 0 Synchronization is lost. 1 Synchronization is achieved.	0x0	R/W
0x471	FRAMESYNCFLG	[7:0]	FRAMESYNC		Frame sync flag (from each instantiated lane). This register indicates the live status for each lane. Writing 1 to Bit 7 resets the IRQ. A loss of frame sync automatically initiates a synchronization sequence. 0 Synchronization is lost. 1 Synchronization is achieved.	0x0	R/W
0x472	GOODCHKSUMFLG	[7:0]	GOODCHECKSUM		Good checksum flag (from each instantiated lane). Writing 1 to Bit 7 resets the IRQ. The associated IRQ flag is located in Register 0x47A[2]. 0 Last computed checksum is not correct. 1 Last computed checksum is correct.	0x0	R/W
0x473	INITLANESYNCFLG	[7:0]	INITIALLANESYNC		Initial lane syncflag (from each instantiated lane). Writing 1 to Bit 7 resets the IRQ. The associated IRQ flag is located in Register 0x47A[3]. Loss of synchronization is also reported on SYNCOUT±. See the SYNCOUT±, SYSREF±, and DACCLK±/REFCLK± Signals section and the Deterministic Latency section.	0x0	R/W
0x476	CTRLREG1	[7:0]	F		Number of Octets per Frame. Settings of 1, 2, and 4 are valid. See Table 33. 1 One octet per frame. 2 Two octets per frame. 4 Four octets per frame.	0x1	R/W
0x477	CTRLREG2	7	ILAS_MODE		ILAS test mode. Defined in Section 5.3.3.8 of JESD204B specification.	0x0	R/W

Addr.	Name	Bits	Bit Name	Settings	Description	Reset	Access
				1	JESD204B receiver is constantly receiving ILAS frames.		
				0	Normal link operation.		
		[6:4]	RESERVED		Reserved.	0x0	R/W
		3	THRESHOLD_MASK_EN		Threshold mask enable. Set this bit if using SYNC_ASSERTION_MASK (Register 0x47B[7:5]).	0x0	R/W
		[2:0]	RESERVED		Reserved.	0x0	R/W
0x478	KVAL	[7:0]	KSYNC	x	Number of K multiframes during ILAS (divided by four). Sets the number of multiframes to send initial lane alignment sequence. Cannot be set to 0. 4x multiframes during ILAS.	0x1	R/W
0x47A	IRQVECTOR_FLAG	7	BADDIS_FLAG	1	Bad disparity error Count. Bad disparity character count reached ERRORTHRESH (0x47C) on at least one lane. Read Register 0x46D to determine which lanes are in error.	0x0	R
		6	NIT_FLAG	1	Not in table error count. Not in table character count reached ERRORTHRESH (0x47C) on at least one lane. Read Register 0x46E to determine which lanes are in error.	0x0	R
		5	UCC_FLAG	1	Unexpected control character error count. Unexpected control character count reached ERRORTHRESH (0x47C) on at least one lane. Read Register 0x46F to determine which lanes are in error.	0x0	R
		4	RESERVED		Reserved.	0x0	R
		3	INITIALLANESYNC_FLAG	1	Initial lane sync fag. Initial lane sync failed on at least one lane. Read Register 0x473 to determine which lanes are in error.	0x0	R
		2	BADCHECKSUM_FLAG	1	Bad checksum flag. Bad checksum on at least one lane. Read Register 0x472 to determine which lanes are in error.	0x0	R
		1	FRAMESYNC_FLAG	1	Frame sync flag. Frame sync failed on at least one lane. Read Register 0x471 to determine which lanes are in error.	0x0	R
		0	CODEGRPSYNC_FLAG	1	Code group sync flag. Code group sync failed on at least one lane. Read Register 0x470 to determine which lanes are in error.	0x0	R
0x47A	IRQVECTOR_MASK	7	BADDIS_MASK	1	Bad disparity mask. If the bad disparity count reaches ERRORTHRESH on any lane, $\overline{\text{IRQ}}$ is pulled low.	0x0	W
		6	NIT_MASK	1	Not in table mask. If the not in table character count reaches ERRORTHRESH on any lane, $\overline{\text{IRQ}}$ is pulled low.	0x0	W
		5	UCC_MASK	1	Unexpected control character mask. If the unexpected control character count reaches ERRORTHRESH on any lane, $\overline{\text{IRQ}}$ is pulled low.	0x0	W
		4	RESERVED		Reserved.	0x0	R
		3	INITIALLANESYNC_MASK	1	Initial lane sync mask. If initial lane sync (0x473) fails on any lane, $\overline{\text{IRQ}}$ is pulled low.	0x0	W
		2	BADCHECKSUM_MASK	1	Bad checksum mask. If there is a bad checksum (0x472) on any lane, $\overline{\text{IRQ}}$ is pulled low.	0x0	W
		1	FRAMESYNC_MASK	1	Frame sync mask. If frame sync (0x471) fails on any lane, $\overline{\text{IRQ}}$ is pulled low.	0x0	W
		0	CODEGRPSYNC_MASK	1	Code group sync machine mask. If code group sync (0x470) fails on any lane, $\overline{\text{IRQ}}$ is pulled low.	0x0	W
0x47B	SYNCASSERTIONMASK	7	BADDIS_S	1	Bad disparity error on sync. The deframer asserts the SYNCOUT± signal when the bad disparity error count reaches the threshold in Register 0x47C.	0x0	R/W

Addr.	Name	Bits	Bit Name	Settings	Description	Reset	Access
				0	The deframer does not assert the SYNCOUT± when the bad disparity error count reaches the threshold in Register 0x47C.		
		6	NIT_S	1 0	Not in table disparity character error on sync. The deframer asserts the SYNCOUT± signal when the not in table disparity character error count reaches the threshold in Register 0x47C. The deframer does not assert the SYNCOUT± when the not in table disparity character error count reaches the threshold on Register 0x47C.	0x0	R/W
		5	UCC_S	1 0	Unexpected K character error on sync. The deframer asserts the SYNCOUT± signal when the unexpected K character error count reaches the threshold in Register 0x47C. The deframer does not assert the SYNCOUT± when the unexpected K character error count reaches the threshold in Register 0x47C.	0x0	R/W
		4	CMM	1 0	Writing a 1 resets the CMM_IRQ (applicable if Register 0x47B, Bit 3 = 1) Configuration mismatch flag when read. Lane 0 configuration registers (Register 0x450 to Register 0x45D) do not match the comparable JESD204B transmit settings as reported in Register 0x400 to Register 0x40D. Lane 0 configuration registers (Register 0x450 to Register 0x45D) match the comparable JESD Tx settings as reported in Register 0x400 to Register 0x40D.	0x0	R/W
		3	CMM_ENABLE	1 0	Configuration mismatch IRQ enable. Enables IRQ generation if a configuration mismatch is detected. Configuration mismatch IRQ disabled.	0x1	R/W
		[2:0]	RESERVED			0x0	R/W
0x47C	ERRORTHRES	[7:0]	ETH		Error threshold. Bad disparity, not in table, and unexpected control character errors are counted and compared to the error threshold value. When the count reaches the threshold, either an IRQ is generated or the SYNCOUT± signal is asserted per the mask register settings, or both. Function is performed in all lanes.	0xFF	R/W
0x47D	LANEENABLE	[7:4]	RESERVED		Reserved.	0x0	R
		[3:0]	LANE_ENA		Lane Enable. Setting Bit x enables Lane x. This register must be programmed before receiving the code group pattern for proper operation.	0xF	R/W
0x47E	RAMP_ENA	[7:1]	RESERVED		Reserved.	0x0	R
		0	ENA_RAMP_CHECK	0 1	Enable ramp checking at the beginning of ILAS. Disable ramp checking at beginning of ILAS; ILAS data need not be a ramp. Enable ramp checking; ILAS data needs to be a ramp starting at 00-01-02; otherwise, the ramp ILAS fails and the device does not start up.	0x0	W

OUTLINE DIMENSIONS

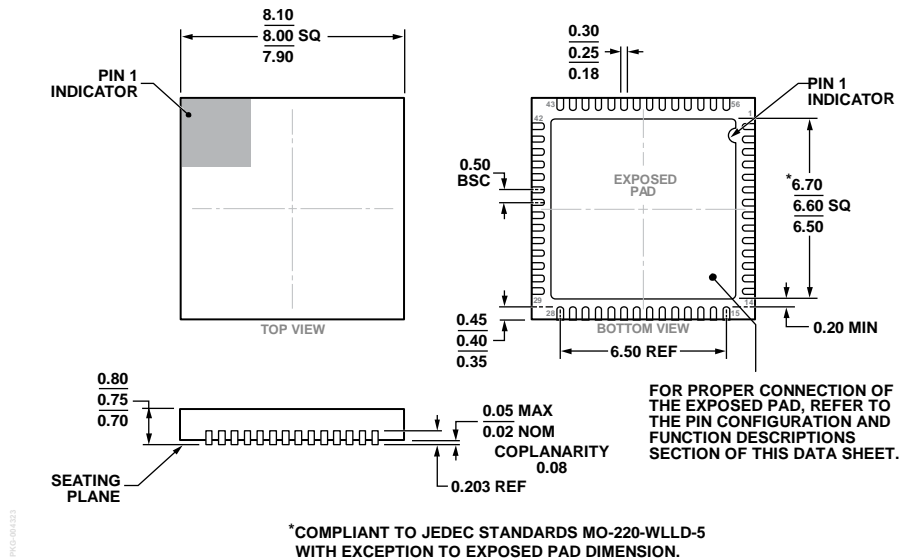

Figure 78. 56-Lead Lead Frame Chip Scale Package [LFCSP]  
 8 mm × 8 mm Body and 0.75 mm Package Height  
 (CP-56-9)  
 Dimensions shown in millimeters

ORDERING GUIDE

Model <sup>1</sup>	Temperature Range	Package Description	Package Option
AD9152BCPZ	-40°C to +85°C	56-Lead Lead Frame Chip Scale Package [LFCSP]	CP-56-9
AD9152BCPZRL	-40°C to +85°C	56-Lead Lead Frame Chip Scale Package [LFCSP]	CP-56-9
AD9152-EBZ		DPG3 Evaluation Board	
AD9152-FMC-EBZ		FMC Evaluation Board	
AD9152-M6720-EBZ		DPG3 Evaluation Board with <a href="#">ADRF6720</a> Modulator	

<sup>1</sup> Z = RoHS Compliant Part.

## Looking for pricing, stock, or lifecycle information?

Click below to explore more details on WIN SOURCE:

 [View AD9152BCPZ on WIN SOURCE](#)

 [Analog Devices Inc. Information](#)

## Optimize Your Supply Chain with WIN SOURCE Solutions

-  Global Sourcing Solution
-  Obsolete Management
-  Cost Control Management
-  Shortage Management
-  Alternative Solution
-  Excess Inventory Management