



**THE DATASHEET OF
ST72F321AR9TAE**





ST72321xx-Auto

8-bit MCU for automotive with 32/60 Kbyte Flash/ROM, ADC, 5 timers, SPI, SCI, I2C interface

Features

Memories

- 32 to 60 Kbyte dual voltage High Density Flash (HDFlash) or ROM ROM with readout protection capability. In-application programming and in-circuit programming for HDFlash devices
- 1 to 2 Kbyte RAM
- HDFlash endurance: 100 cycles, data retention 20 years

Clock, reset and supply management

- Enhanced low voltage supervisor (LVD) for main supply and auxiliary voltage detector (AVD) with interrupt capability
- Clock sources: crystal/ceramic resonator oscillators, internal RC oscillator and bypass for external clock
- PLL for 2x frequency multiplication
- 4 power saving modes: Halt, Active Halt, Wait and Slow

Interrupt management

- Nested interrupt controller
- 14 interrupt vectors plus TRAP and RESET
- Top Level Interrupt (TLI) pin on 64-pin devices
- 15 external interrupt lines (on 4 vectors)

1 analog peripheral

- 10-bit ADC with up to 16 input ports

Up to 48 I/O ports

- 48//32 multifunctional bidirectional I/O lines
- 34//22 alternate function lines
- 16//12 high sink outputs

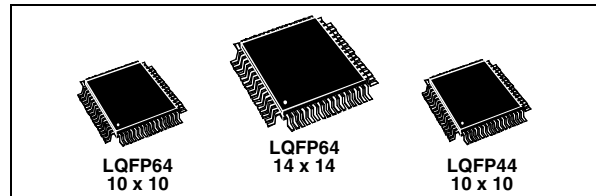

5 timers

- Main clock controller with Real-time base, Beep and Clock-out capabilities
- Configurable watchdog timer
- Two 16-bit timers with 2 input captures, 2 output compares, external clock input on 1 timer, PWM and pulse generator modes
- 8-bit PWM auto-reload timer with 2 input captures, 4 PWM outputs, output compare and time base interrupt, external clock with event detector

3 communications interfaces

- SPI synchronous serial interface
- SCI asynchronous serial interface
- I²C multimaster interface

Instruction set

- 8-bit data manipulation
- 63 basic instructions
- 17 main addressing modes
- 8x8 unsigned multiply instruction

Development tools

- Full hardware/software development package, ICT capability

Table 1. Device summary

Reference	Part number
ST72321xx-Auto	ST72321AR6-Auto, ST72321R6-Auto, ST72321AR7-Auto, ST72321J7-Auto, ST72321R7-Auto ST72321AR9-Auto, ST72321J9-Auto, ST72321R9-Auto

Contents

1	Description	18
2	Package pinout and pin description	20
	2.1 Package pinout	20
	2.2 Pin description	22
3	Register and memory map	26
4	Flash program memory	29
	4.1 Introduction	29
	4.2 Main features	29
	4.3 Structure	29
	4.3.1 Readout protection	30
	4.4 ICC interface	30
	4.5 ICP (in-circuit programming)	31
	4.6 IAP (in-application programming)	32
	4.7 Related documentation	32
	4.8 Flash control/status register (FCSR)	32
5	Central processing unit (CPU)	33
	5.1 Introduction	33
	5.2 Main features	33
	5.3 CPU registers	33
	5.3.1 Accumulator (A)	34
	5.3.2 Index registers (X and Y)	34
	5.3.3 Program counter (PC)	34
	5.3.4 Condition code (CC) register	34
	5.3.5 Stack pointer (SP) register	35
6	Supply, reset and clock management	37
	6.1 Introduction	37
	6.2 Main features	37
	6.3 Phase locked loop	38

6.4	Multi-oscillator (MO)	38
6.5	Reset sequence manager (RSM)	40
6.5.1	Introduction	40
6.5.2	Asynchronous external RESET pin	41
6.5.3	External power-on RESET	41
6.5.4	Internal low voltage detector (LVD) RESET	41
6.5.5	Internal watchdog RESET	42
6.6	System integrity management (SI)	43
6.6.1	Low voltage detector (LVD)	43
6.6.2	Auxiliary voltage detector (AVD)	44
6.6.3	Low power modes	46
6.6.4	Interrupts	46
6.6.5	System Integrity (SI) Control/Status register (SICSR)	47
7	Interrupts	49
7.1	Introduction	49
7.2	Masking and processing flow	49
7.3	Interrupts and low power modes	52
7.4	Concurrent and nested management	52
7.5	Interrupt register description	53
7.5.1	CPU CC register interrupt bits	53
7.5.2	Interrupt software priority registers (ISPRx)	54
7.6	External interrupts	57
7.6.1	I/O port interrupt sensitivity	57
7.6.2	External interrupt control register (EICR)	59
8	Power saving modes	62
8.1	Introduction	62
8.2	Slow mode	62
8.3	Wait mode	63
8.4	Active Halt and Halt modes	65
8.4.1	Active Halt mode	65
8.4.2	Halt mode	67
9	I/O ports	70
9.1	Introduction	70

9.2	Functional description	70
9.2.1	Input modes	70
9.2.2	Output modes	71
9.2.3	Alternate functions	71
9.3	I/O port implementation	74
9.4	Low power modes	75
9.5	Interrupts	75
10	Watchdog timer (WDG)	77
10.1	Introduction	77
10.2	Main features	77
10.3	Functional description	77
10.4	How to program the watchdog timeout	78
10.5	Low power modes	80
10.6	Hardware watchdog option	80
10.7	Using Halt mode with the WDG (WDGHALT option)	80
10.8	Interrupts	80
10.9	Register description	81
10.9.1	Control register (WDGCR)	81
11	Main clock controller with real-time clock and beeper (MCC/RTC)	82
11.1	Introduction	82
11.2	Programmable CPU clock prescaler	82
11.3	Clock-out capability	82
11.4	Real-time clock timer (RTC)	82
11.5	Beeper	82
11.6	Low power modes	83
11.7	Interrupts	83
11.8	Main clock controller registers	84
11.8.1	MCC control/status register (MCCSR)	84
11.8.2	MCC beep control register (MCCBCR)	85
12	PWM auto-reload timer (ART)	87
12.1	Introduction	87
12.2	Functional description	88

12.2.1	Counter	88
12.2.2	Counter clock and prescaler	88
12.2.3	Counter and prescaler initialization	88
12.2.4	Output compare control	88
12.2.5	Independent PWM signal generation	89
12.2.6	Output compare and time base interrupt	90
12.2.7	External clock and event detector mode	90
12.2.8	Input capture function	91
12.2.9	External interrupt capability	92
12.3	ART registers	93
12.3.1	Control/status register (ARTCSR)	93
12.3.2	Counter access register (ARTCAR)	94
12.3.3	Auto-reload register (ARTARR)	94
12.3.4	PWM control register (PWMCR)	95
12.3.5	Duty cycle registers (PWMDCRx)	96
12.3.6	Input capture control / status register (ARTICCSR)	96
12.3.7	Input capture registers (ARTICRx)	97
13	16-bit timer	98
13.1	Introduction	98
13.2	Main features	98
13.3	Functional description	99
13.3.1	Counter	99
13.3.2	External clock	102
13.3.3	Input capture	103
13.3.4	Output compare	105
13.3.5	Forced compare output capability	106
13.3.6	One Pulse mode	108
13.3.7	Pulse width modulation mode	110
13.4	Low power modes	112
13.5	Interrupts	112
13.6	Summary of timer modes	112
13.7	16-bit timer registers	113
13.7.1	Control register 1 (CR1)	113
13.7.2	Control register 2 (CR2)	114
13.7.3	Control/status register (CSR)	115

13.7.4	Input capture 1 high register (IC1HR)	116
13.7.5	Input capture 1 low register (IC1LR)	117
13.7.6	Output compare 1 high register (OC1HR)	117
13.7.7	Output compare 1 low register (OC1LR)	117
13.7.8	Output compare 2 high register (OC2HR)	117
13.7.9	Output compare 2 low register (OC2LR)	118
13.7.10	Counter high register (CHR)	118
13.7.11	Counter low register (CLR)	118
13.7.12	Alternate counter high register (ACHR)	118
13.7.13	Alternate counter low register (ACLR)	119
13.7.14	Input capture 2 high register (IC2HR)	119
13.7.15	Input capture 2 low register (IC2LR)	119
14	Serial peripheral interface (SPI)	121
14.1	Introduction	121
14.2	Main features	121
14.3	General description	121
14.3.1	Functional description	122
14.3.2	Slave select management	123
14.3.3	Master mode operation	124
14.3.4	Master mode transmit sequence	125
14.3.5	Slave mode operation	125
14.3.6	Slave mode transmit sequence	125
14.4	Clock phase and clock polarity	126
14.5	Error flags	128
14.5.1	Master mode fault (MODF)	128
14.5.2	Overrun condition (OVR)	128
14.5.3	Write collision error (WCOL)	128
14.5.4	Single master systems	129
14.6	Low power modes	130
14.6.1	Using the SPI to wake up the MCU from Halt mode	130
14.7	Interrupts	130
14.8	SPI registers	131
14.8.1	Control register (SPICR)	131
14.8.2	Control/status register (SPICSR)	132
14.8.3	Data I/O register (SPIDR)	133

15	Serial communications interface (SCI)	135
15.1	Introduction	135
15.2	Main features	135
15.3	General description	136
15.4	Functional description	138
15.4.1	Serial data format	138
15.4.2	Transmitter	139
15.4.3	Receiver	140
15.5	Low power modes	146
15.6	Interrupts	146
15.7	SCI registers	147
15.7.1	Status register (SCISR)	147
15.7.2	Control register 1 (SCICR1)	149
15.7.3	Control register 2 (SCICR2)	150
15.7.4	Data register (SCIDR)	151
15.7.5	Baud rate register (SCIBRR)	151
15.7.6	Extended receive prescaler division register (SCIERPR)	152
15.7.7	Extended transmit prescaler division register (SCIETPR)	153
16	I2C bus interface (I2C)	155
16.1	Introduction	155
16.2	Main features	155
16.2.1	I2C master features	155
16.2.2	I2C slave features	155
16.3	General description	156
16.3.1	Mode selection	156
16.3.2	Communication flow	156
16.3.3	SDA/SCL line control	157
16.4	Functional description	158
16.4.1	Slave mode	158
16.4.2	Master mode	159
16.5	Low power modes	163
16.6	Interrupts	163
16.7	Register description	164
16.7.1	I2C control register (CR)	164

16.7.2	I2C status register 1 (SR1)	165
16.7.3	I2C status register 2 (SR2)	167
16.7.4	I2C clock control register (CCR)	168
16.7.5	I2C data register (DR)	169
16.7.6	I2C own address register (OAR1)	169
16.7.7	I2C own address register (OAR2)	170
17	10-bit A/D converter (ADC)	172
17.1	Introduction	172
17.2	Main features	172
17.3	Functional description	173
17.3.1	A/D converter configuration	173
17.3.2	Starting the conversion	173
17.3.3	Changing the conversion channel	174
17.4	Low power modes	174
17.5	Interrupts	174
17.6	ADC registers	174
17.6.1	Control/status register (ADCCSR)	174
17.6.2	Data register (ADCDRH)	175
17.6.3	Data register (ADCDDL)	176
17.6.4	ADC register map and reset values	176
18	Instruction set	177
18.1	CPU addressing modes	177
18.1.1	Inherent	178
18.1.2	Immediate	179
18.1.3	Direct	179
18.1.4	Indexed (no offset, short, long)	179
18.1.5	Indirect (short, long)	180
18.1.6	Indirect Indexed (Short, Long)	180
18.1.7	Relative (Direct, Indirect)	181
18.2	Instruction groups	181
18.2.1	Using a prebyte	182
19	Electrical characteristics	185
19.1	Parameter conditions	185

19.1.1	Minimum and maximum values	185
19.1.2	Typical values	185
19.1.3	Typical curves	185
19.1.4	Loading capacitor	185
19.1.5	Pin input voltage	185
19.2	Absolute maximum ratings	186
19.2.1	Voltage characteristics	186
19.2.2	Current characteristics	187
19.2.3	Thermal characteristics	187
19.3	Operating conditions	188
19.3.1	General operating conditions	188
19.3.2	Operating conditions with low voltage detector (LVD)	189
19.3.3	Auxiliary voltage detector (AVD) thresholds	189
19.3.4	External voltage detector (EVD) thresholds	190
19.4	Supply current characteristics	191
19.4.1	Current consumption	191
19.4.2	Supply and clock managers	193
19.4.3	On-chip peripherals	194
19.5	Clock and timing characteristics	195
19.5.1	General timings	195
19.5.2	External clock source	195
19.5.3	Crystal and ceramic resonator oscillators	196
19.5.4	RC oscillators	197
19.5.5	PLL characteristics	198
19.6	Memory characteristics	199
19.6.1	RAM and hardware registers	199
19.6.2	Flash memory	199
19.7	EMC (electromagnetic compatibility) characteristics	200
19.7.1	Functional EMS (electromagnetic susceptibility)	200
19.7.2	EMI (electromagnetic interference)	201
19.7.3	Absolute maximum ratings (electrical sensitivity)	202
19.8	I/O port pin characteristics	203
19.8.1	General characteristics	203
19.8.2	Output driving current	204
19.9	Control pin characteristics	207
19.9.1	Asynchronous $\overline{\text{RESET}}$ pin	207

19.9.2	ICCSEL/V _{PP} pin	209
19.10	Timer peripheral characteristics	210
19.11	Communication interface characteristics	211
19.11.1	SPI (serial peripheral interface)	211
19.11.2	I ² C - inter IC control interface	214
19.12	10-bit ADC characteristics	216
19.12.1	Analog power supply and reference pins	217
19.12.2	General PCB design guidelines	218
19.12.3	ADC accuracy	219
20	Package characteristics	220
20.1	Thermal characteristics	222
20.2	Ecopack information	222
20.3	Packaging for automatic handling	222
21	Device configuration and ordering information	223
21.1	Flash devices	223
21.1.1	Flash configuration	223
21.1.2	Flash ordering information	226
21.2	ROM device ordering information and transfer of customer code	227
21.3	Development tools	231
21.3.1	Introduction	231
21.3.2	Evaluation tools and starter kits	231
21.3.3	Development and debugging tools	231
21.3.4	Programming tools	231
21.3.5	Socket and emulator adapter information	232
21.4	ST7 application notes	233
22	Known limitations	234
22.1	All Flash and ROM devices	234
22.1.1	External RC option	234
22.1.2	Safe connection of OSC1/OSC2 pins	234
22.1.3	Reset pin protection with LVD enabled	234
22.1.4	Unexpected reset fetch	234
22.1.5	External interrupt missed	234
22.1.6	Clearing active interrupts outside interrupt routine	238

22.1.7	SCI wrong break duration	239
22.1.8	16-bit timer PWM mode	239
22.1.9	TIMD set simultaneously with OC interrupt	240
22.1.10	I ² C multimaster	240
22.1.11	Readout protection with LVD	240
22.2	All Flash devices	240
22.2.1	Internal RC oscillator with LVD	240
22.3	Limitations specific to ROM devices	240
22.3.1	LVD operation	240
22.3.2	LVD startup behavior	241
22.3.3	AVD not supported	241
22.3.4	Internal RC oscillator operation	241
22.3.5	External clock source with PLL	241
22.3.6	Pull-up not present on PE2	241
22.3.7	Readout protection with LVD	241
23	Revision history	242

List of tables

Table 1.	Device summary	1
Table 2.	Product overview	18
Table 3.	Device pin description.	22
Table 4.	Hardware register map	26
Table 5.	Sectors available in Flash devices	29
Table 6.	Flash control/status register address and reset value	32
Table 7.	Arithmetic management bits	34
Table 8.	Interrupt management bits	35
Table 9.	Interrupt software priority selection	35
Table 10.	ST7 clock sources	39
Table 11.	Effect of low power modes on SI	46
Table 12.	AVD interrupt control/wake-up capability	46
Table 13.	SICSR description	47
Table 14.	Reset source flags	47
Table 15.	Interrupt software priority levels	50
Table 16.	CPU CC register interrupt bits description	53
Table 17.	Interrupt software priority levels	54
Table 18.	Interrupt priority bits	54
Table 19.	Interrupt dedicated instruction set.	55
Table 20.	Interrupt mapping	56
Table 21.	EICR register description	59
Table 22.	Interrupt sensitivity - ei2 (port B3..0)	60
Table 23.	Interrupt sensitivity - ei3 (port B7..4)	60
Table 24.	Interrupt sensitivity - ei0 (port A3..0)	60
Table 25.	Interrupt sensitivity - ei1 (port F2..0)	60
Table 26.	Nested interrupts register map and reset values	61
Table 27.	MCC/RTC low power mode selection.	65
Table 28.	I/O output mode selection.	71
Table 29.	I/O port mode options	72
Table 30.	I/O port configurations	73
Table 31.	I/O port configuration	74
Table 32.	Effect of low power modes on I/O ports	75
Table 33.	I/O port interrupt control/wake-up capability	75
Table 34.	I/O port register map and reset values	75
Table 35.	Effect of low power modes on WDG.	80
Table 36.	WDGCR register description	81
Table 37.	Watchdog timer register map and reset values	81
Table 38.	Effect of low power modes on MCC/RTC	83
Table 39.	MCC/RTC interrupt control/wake-up capability.	83
Table 40.	MCCSR register description	84
Table 41.	Time base selection	85
Table 42.	MCCBCR register description.	85
Table 43.	Beep frequency selection	85
Table 44.	Main clock controller register map and reset values.	86
Table 45.	ARTCSR register description	93
Table 46.	Prescaler selection for ART	93
Table 47.	ARTCAR register description	94
Table 48.	ARTAAR register description	94

Table 49.	PWM frequency versus resolution	95
Table 50.	PWMCR register description	95
Table 51.	PWM output signal polarity selection	95
Table 52.	PWMDCRx register description	96
Table 53.	ARTICCSR register description	96
Table 54.	ARTICRx register description	97
Table 55.	PWM auto-reload timer register map and reset values.	97
Table 56.	Effect of low power modes on 16-bit timer	112
Table 57.	16-bit timer interrupt control/wake-up capability	112
Table 58.	Timer modes	112
Table 59.	CR1 register description	113
Table 60.	CR2 register description	114
Table 61.	Timer clock selection	115
Table 62.	CSR register description	116
Table 63.	16-bit timer register map and reset values	120
Table 64.	Effect of low power modes on SPI	130
Table 65.	SPI interrupt control/wake-up capability	130
Table 66.	SPICR register description	131
Table 67.	SPI master mode SCK frequency	132
Table 68.	SPICSR register description	132
Table 69.	SPI register map and reset values	134
Table 70.	Frame formats	144
Table 71.	Effect of low power modes on SCI	146
Table 72.	SCI interrupt control/wake-up capability	146
Table 73.	SCISR register description	147
Table 74.	SCICR1 register description	149
Table 75.	SCICR2 register description	150
Table 76.	SCIBRR register description	152
Table 77.	SCIERPR register description	153
Table 78.	SCIETPR register description	153
Table 79.	Baud rate selection	153
Table 80.	SCI register map and reset values	154
Table 81.	Effect of low power modes on I2C	163
Table 82.	I2C interrupt control/wake-up capability	163
Table 83.	CR register description	164
Table 84.	SR1 register description	165
Table 85.	SR2 register description	167
Table 86.	CCR register description	168
Table 87.	DR register description	169
Table 88.	OAR1 register description	170
Table 89.	OAR2 register description	170
Table 90.	I2C register map and reset values	171
Table 91.	Effect of low power modes on ADC	174
Table 92.	ADCCSR register description	174
Table 93.	ADCDRH register description	175
Table 94.	ADCDRL register description	176
Table 95.	ADC register map and reset values	176
Table 96.	Addressing modes	177
Table 97.	CPU addressing mode overview	177
Table 98.	Inherent instructions	178
Table 99.	Immediate instructions	179
Table 100.	Instructions supporting direct, indexed, indirect, and indirect indexed addressing modes	180

Table 101.	Available relative direct/indirect instructions	181
Table 102.	Instruction groups	181
Table 103.	Instruction set overview	183
Table 104.	Voltage characteristics	186
Table 105.	Current characteristics	187
Table 106.	Thermal characteristics	187
Table 107.	General operating conditions	188
Table 108.	Operating conditions with low voltage detector (LVD)	189
Table 109.	Auxiliary voltage detector (AVD) thresholds	189
Table 110.	External voltage detector (EVD) thresholds	190
Table 111.	Current consumption	191
Table 112.	Oscillators,PLL and LVD current consumption	193
Table 113.	On-chip peripherals current consumption	194
Table 114.	General timings	195
Table 115.	External clock source	195
Table 116.	Crystal and ceramic resonator oscillators	196
Table 117.	OSCRANGE selection for typical resonators	197
Table 118.	RC oscillator characteristics	197
Table 119.	PLL characteristics	198
Table 120.	RAM supply voltage	199
Table 121.	Dual voltage HDFlash memory	199
Table 122.	EMS test results	201
Table 123.	EMI emissions	201
Table 124.	ESD absolute maximum ratings	202
Table 125.	Electrical sensitivities	202
Table 126.	I/O port pin general characteristics	203
Table 127.	Output driving current	204
Table 128.	Asynchronous RESET pin characteristics	207
Table 129.	ICCSEL/V _{PP} pin characteristics	209
Table 130.	8-bit PWM-ART auto-reload timer characteristics	210
Table 131.	16-bit timer characteristics	210
Table 132.	SPI characteristics	211
Table 133.	I ² C control interface characteristics	214
Table 134.	SCL frequency table	215
Table 135.	10-bit ADC characteristics	216
Table 136.	ADC accuracy	219
Table 137.	64-pin (14x14) low profile quad flat package mechanical data	220
Table 138.	64-pin (10x10) low profile quad flat package mechanical data	221
Table 139.	Thermal characteristics	222
Table 140.	Flash option bytes	223
Table 141.	Option byte 0 bit description	224
Table 142.	Option byte 1 bit description	225
Table 143.	Package selection (OPT7)	225
Table 144.	STMicroelectronics development tools	232
Table 145.	Suggested list of socket types	232
Table 146.	Document revision history	242

List of figures

Figure 1.	Device block diagram	19
Figure 2.	64-pin LQFP 14x14 and 10x10 package pinout	20
Figure 3.	44-pin LQFP package pinout	21
Figure 4.	Memory map	26
Figure 5.	Memory map and sector address	30
Figure 6.	Typical ICC interface	31
Figure 7.	CPU registers	33
Figure 8.	Stack manipulation example	36
Figure 9.	Clock, reset and supply block diagram	37
Figure 10.	PLL block diagram	38
Figure 11.	Reset block diagram	40
Figure 12.	RESET sequence phases	41
Figure 13.	RESET sequences	42
Figure 14.	Low voltage detector versus reset	44
Figure 15.	Using the AVD to monitor V_{DD} (AVDS bit = 0)	45
Figure 16.	Using the voltage detector to monitor the EVD pin (AVDS bit = 1)	46
Figure 17.	Interrupt processing flowchart	50
Figure 18.	Priority decision process flowchart	50
Figure 19.	Concurrent interrupt management	52
Figure 20.	Nested interrupt management	53
Figure 21.	External interrupt control bits	58
Figure 22.	Power saving mode transitions	62
Figure 23.	Slow mode clock transitions	63
Figure 24.	Wait mode flowchart	64
Figure 25.	Active Halt timing overview	66
Figure 26.	Active Halt mode flowchart	66
Figure 27.	Halt timing overview	67
Figure 28.	Halt mode flowchart	68
Figure 29.	I/O port general block diagram	72
Figure 30.	Interrupt I/O port state transitions	74
Figure 31.	Watchdog block diagram	78
Figure 32.	Approximate timeout duration	78
Figure 33.	Exact timeout duration (t_{min} and t_{max})	79
Figure 34.	Main clock controller (MCC/RTC) block diagram	83
Figure 35.	PWM auto-reload timer block diagram	87
Figure 36.	Output compare control	89
Figure 37.	PWM auto-reload timer function	90
Figure 38.	PWM signal from 0% to 100% duty cycle	90
Figure 39.	External event detector example (3 counts)	91
Figure 40.	Input capture timing diagram	92
Figure 41.	Timer block diagram	100
Figure 42.	16-bit read sequence	101
Figure 43.	Counter timing diagram, internal clock divided by 2	102
Figure 44.	Counter timing diagram, internal clock divided by 4	102
Figure 45.	Counter timing diagram, internal clock divided by 8	102
Figure 46.	Input capture block diagram	104
Figure 47.	Input capture timing diagram	104
Figure 48.	Output compare block diagram	107

Figure 49.	Output compare timing diagram, $f_{\text{TIMER}} = f_{\text{CPU}}/2$	107
Figure 50.	Output compare timing diagram, $f_{\text{TIMER}} = f_{\text{CPU}}/4$	107
Figure 51.	One pulse mode cycle flowchart	108
Figure 52.	One pulse mode timing example	109
Figure 53.	Pulse width modulation mode timing example with 2 output compare functions	110
Figure 54.	Pulse width modulation cycle flowchart	111
Figure 55.	Serial peripheral interface block diagram	122
Figure 56.	Single master/single slave application	123
Figure 57.	Generic SS timing diagram	124
Figure 58.	Hardware/Software slave select management	124
Figure 59.	Data clock timing diagram	127
Figure 60.	Clearing the WCOL bit (Write Collision Flag) software sequence	129
Figure 61.	Single master / multiple slave configuration	129
Figure 62.	SCI block diagram	137
Figure 63.	Word length programming	138
Figure 64.	SCI baud rate and extended prescaler block diagram	142
Figure 65.	Bit sampling in reception mode	146
Figure 66.	I2C bus protocol	156
Figure 67.	I2C interface block diagram	157
Figure 68.	Transfer sequencing	162
Figure 69.	Interrupt control logic diagram	163
Figure 70.	ADC block diagram	172
Figure 71.	Pin loading conditions	185
Figure 72.	Pin input voltage	185
Figure 73.	f_{CPU} max versus V_{DD}	188
Figure 74.	Typical I_{DD} in Run mode	192
Figure 75.	Typical I_{DD} in Slow mode	192
Figure 76.	Typical I_{DD} in Wait mode	192
Figure 77.	Typical I_{DD} in Slow Wait mode	193
Figure 78.	Typical application with an external clock source	195
Figure 79.	Typical application with a crystal or ceramic resonator)	196
Figure 80.	Typical $f_{\text{OSC(RCINT)}}$ versus T_{A}	197
Figure 81.	Integrated PLL jitter versus signal frequency(1)	198
Figure 82.	Unused I/O pins configured as input.	204
Figure 83.	Typical I_{PU} vs V_{DD} with $V_{\text{IN}} = V_{\text{SS}}$	204
Figure 84.	Typical V_{OL} at $V_{\text{DD}} = 5\text{V}$ (standard)	205
Figure 85.	Typical V_{OL} at $V_{\text{DD}} = 5\text{V}$ (high-sink)	205
Figure 86.	Typical V_{OH} at $V_{\text{DD}} = 5\text{V}$	205
Figure 87.	Typical V_{OL} versus V_{DD} (standard)	206
Figure 88.	Typical V_{OL} versus V_{DD} (high-sink)	206
Figure 89.	Typical $V_{\text{DD}} - V_{\text{OH}}$ versus V_{DD}	206
Figure 90.	$\overline{\text{RESET}}$ pin protection when LVD is enabled	208
Figure 91.	$\overline{\text{RESET}}$ pin protection when LVD is disabled	209
Figure 92.	Two typical applications with ICCSEL/ V_{PP} pin(1)	210
Figure 93.	SPI slave timing diagram with CPHA = 0(1)	212
Figure 94.	SPI slave timing diagram with CPHA = 1(1)	212
Figure 95.	SPI master timing diagram(1)	213
Figure 96.	Typical application with I ² C BUS and timing diagram(1)	215
Figure 97.	R_{AIN} maximum versus f_{ADC} with $C_{\text{AIN}} = 0\text{pF}$ (1)	217
Figure 98.	Recommended C_{AIN} and R_{AIN} values(1)	217
Figure 99.	Typical A/D converter application	217
Figure 100.	Power supply filtering	218

Figure 101. ADC error classification	219
Figure 102. 64-pin (14x14) low profile quad flat package outline	220
Figure 103. 64-pin (10x10) low profile quad flat package outline	221
Figure 104. Pin 1 orientation in tape and reel conditioning	222
Figure 105. ST72F321xxx-Auto Flash commercial product structure	226
Figure 106. ST72P321xxx-Auto FastROM commercial product structure	228
Figure 107. ST72321xxx-Auto ROM commercial product structure	229
Figure 108. LVD startup behavior	241

1 Description

The ST72321xx-Auto Flash and ROM devices are members of the ST7 microcontroller family designed for mid-range automotive applications running from 3.8 to 5.5V.

All devices are based on a common industry-standard 8-bit core, featuring an enhanced instruction set and are available with Flash program memory. The ST7 family architecture offers both power and flexibility to software developers, enabling the design of highly efficient and compact application code.

The on-chip peripherals include an A/D converter, a PWM autoreload timer, two general purpose timers, I²C, SPI, SCI interfaces.

For power economy, the microcontroller can switch dynamically into Wait, Slow, Active Halt or Halt mode when the application is in idle or standby state.

Table 2. Product overview

Reference	Program memory	RAM (stack)	Voltage range	Temp. range	Package
ST72321R9-Auto	60 Kbytes Flash/ROM	2048 (256) bytes	3.8V to 5.5V	Up to -40°C to 125°C	LQFP64 14x14
ST72321AR9-Auto					LQFP64 10x10
ST72321J9-Auto					LQFP48 10x10
ST72321R7-Auto	48 Kbytes Flash/ROM	1536 (256) byte			LQFP64 14x14
ST72321AR7-Auto					LQFP64 10x10
ST72321J7-Auto					LQFP48 10x10
ST72321R6-Auto	32 Kbytes Flash/ROM	1024 (256) byte			LQFP64 14x14
ST72321AR6-Auto					LQFP64 10x10

Typical applications include

- all types of car body applications such as window lift, DC motor control, rain sensors
- safety microcontroller in airbag and engine management applications
- auxiliary functions in car radios

Figure 1. Device block diagram

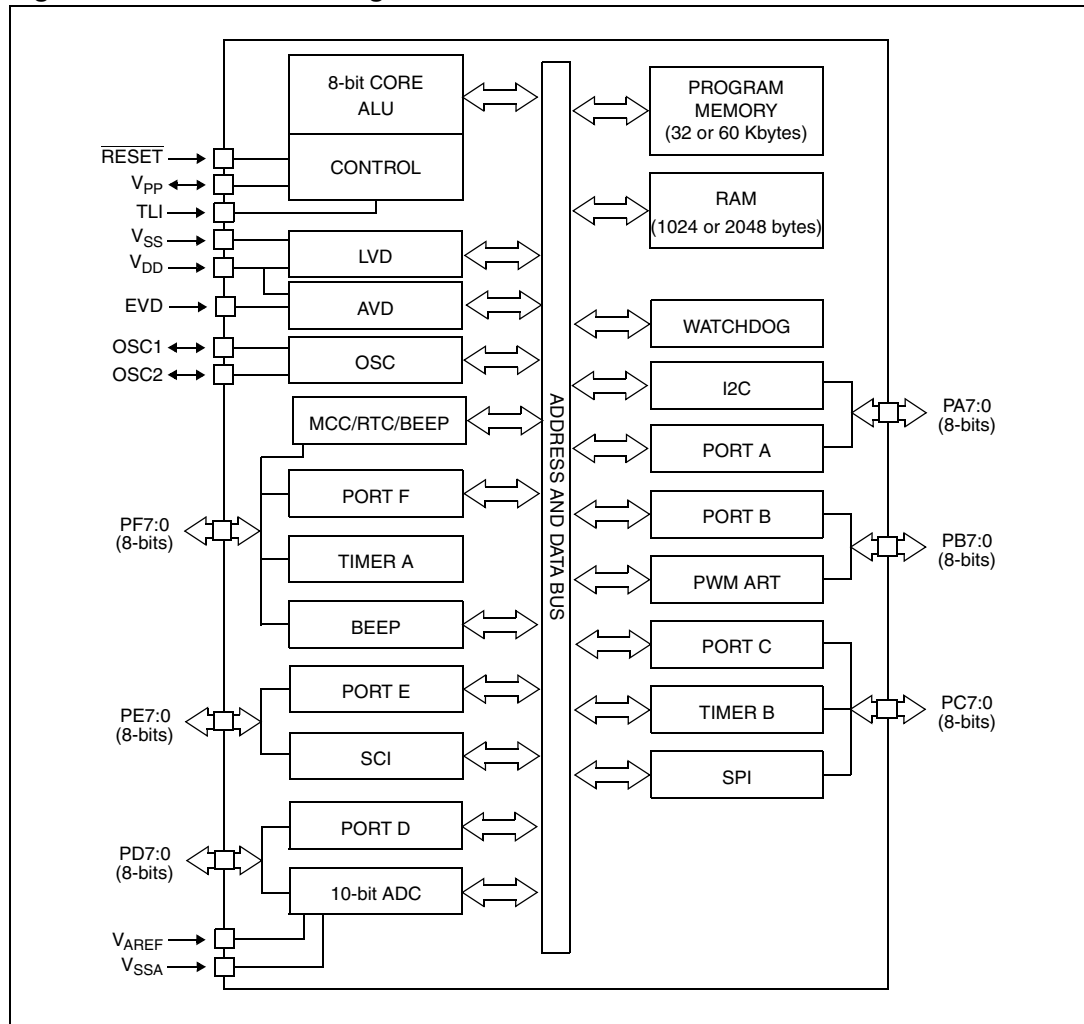

2 Package pinout and pin description

2.1 Package pinout

Figure 2. 64-pin LQFP 14x14 and 10x10 package pinout

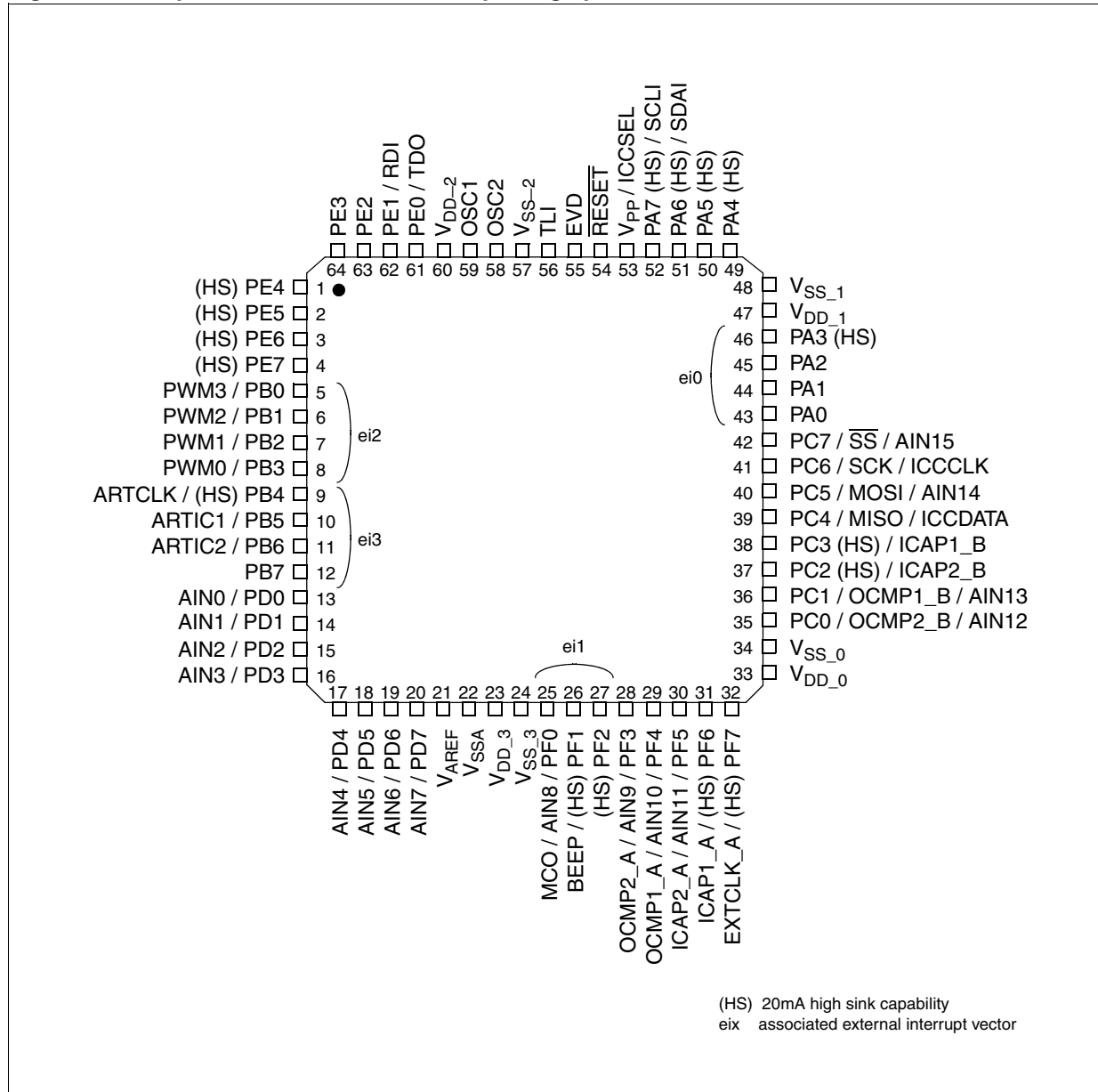

For external pin connection guidelines, refer to [Section 19: Electrical characteristics](#).

Figure 3. 44-pin LQFP package pinout

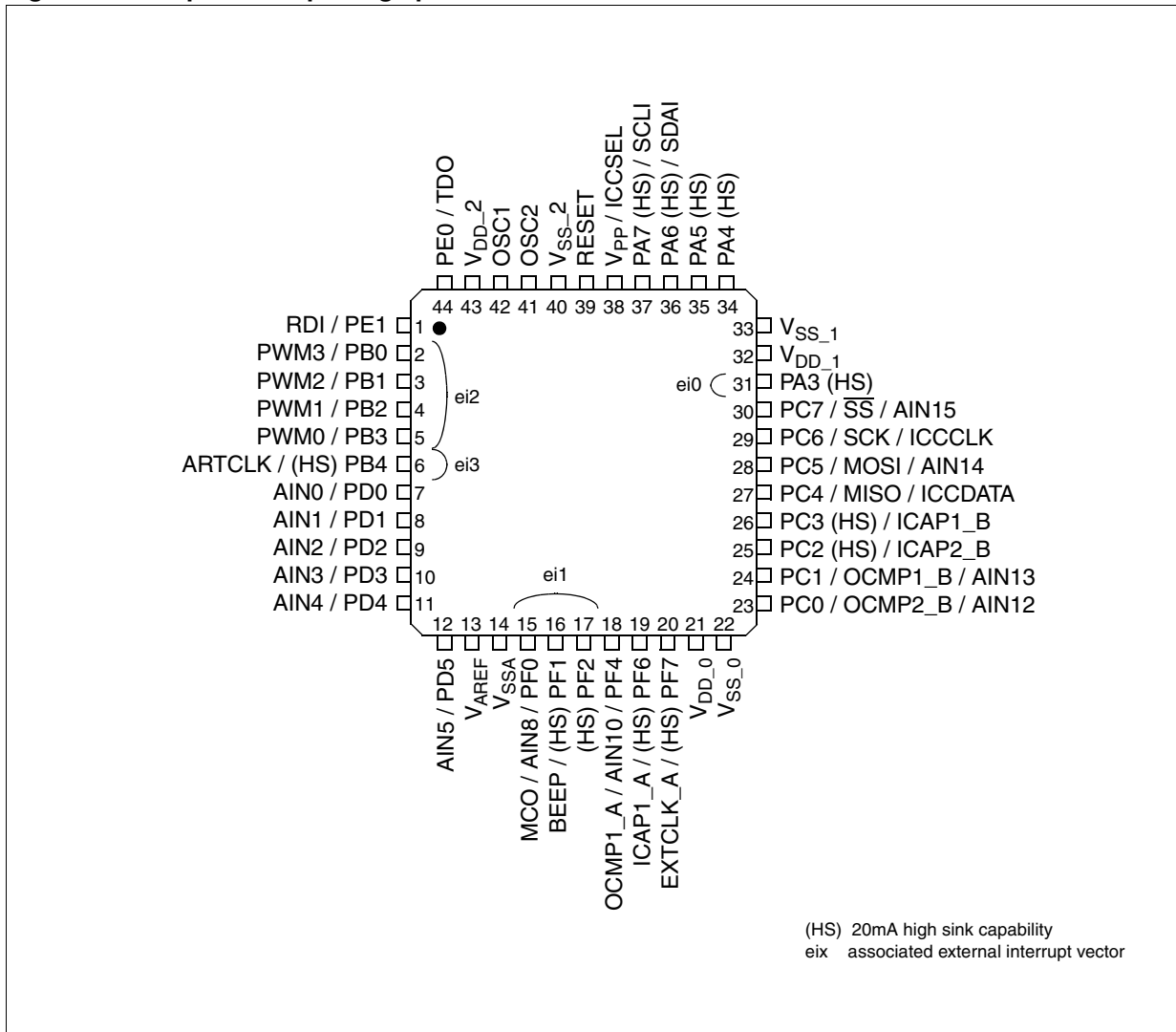

2.2 Pin description

In the device pin description table, the RESET configuration of each pin is shown in bold. This configuration is valid as long as the device is in reset state.

Refer to [Section 9: I/O ports on page 70](#) for more details on the software configuration of the I/O ports.

Table 3. Device pin description

Pin No.		Pin name	Type	Level		Port						Main function (after reset)	Alternate function
LQFP64	LQFP44			Input	Output	Input				Output			
						float	wpu	int	ana	OD	PP		
1	-	PE4(HS)	I/O	C _T	HS	X	X			X	X	Port E4	
2	-	PE5(HS)	I/O	C _T	HS	X	X			X	X	Port E5	
3	-	PE6(HS)	I/O	C _T	HS	X	X			X	X	Port E6	
4	-	PE7(HS)	I/O	C _T	HS	X	X			X	X	Port E7	
5	2	PB0/PWM3	I/O	C _T		X	ei2			X	X	Port B0	PWM Output 3
6	3	PB1/PWM2	I/O	C _T		X	ei2			X	X	Port B1	PWM Output 2
7	4	PB2/PWM1	I/O	C _T		X	ei2			X	X	Port B2	PWM Output 1
8	5	PB3/PWM0	I/O	C _T		X	ei2			X	X	Port B3	PWM Output 0
9	6	PB4(HS)/ARTCLK	I/O	C _T	HS	X	ei3			X	X	Port B4	PWM-ART External Clock
10	-	PB5 / ARTIC1	I/O	C _T		X	ei3			X	X	Port B5	PWM-ART Input Capture 1
11	-	PB6 / ARTIC2	I/O	C _T		X	ei3			X	X	Port B6	PWM-ART Input Capture 2
12	-	PB7	I/O	C _T		X	ei3			X	X	Port B7	
13	7	PD0/AIN0	I/O	C _T		X	X		X	X	X	Port D0	ADC Analog Input 0
14	8	PD1/AIN1	I/O	C _T		X	X		X	X	X	Port D1	ADC Analog Input 1
15	9	PD2/AIN2	I/O	C _T		X	X		X	X	X	Port D2	ADC Analog Input 2
16	10	PD3/AIN3	I/O	C _T		X	X		X	X	X	Port D3	ADC Analog Input 3
17	11	PD4/AIN4	I/O	C _T		X	X		X	X	X	Port D4	ADC Analog Input 4
18	12	PD5/AIN5	I/O	C _T		X	X		X	X	X	Port D5	ADC Analog Input 5
19	-	PD6/AIN6	I/O	C _T		X	X		X	X	X	Port D6	ADC Analog Input 6
20	-	PD7/AIN7	I/O	C _T		X	X		X	X	X	Port D7	ADC Analog Input 7
21	13	V _{AREF} ⁽¹⁾	I									Analog Reference Voltage for ADC	
22	14	V _{SSA} ⁽¹⁾	S									Analog Ground Voltage	
23	-	V _{DD_3} ⁽¹⁾	S									Digital Main Supply Voltage	
24	-	V _{SS_3} ⁽¹⁾	S									Digital Ground Voltage	

Table 3. Device pin description (continued)

Pin No.		Pin name	Type	Level		Port						Main function (after reset)	Alternate function	
LQFP64	LQFP44			Input	Output	Input				Output				
						float	wpu	int	ana	OD	PP			
25	15	PF0/MCO/AIN8	I/O	C _T		X	ei1	X	X	X	Port F0	Main clock out (f _{OSC} /2)	ADC Analog Input 8	
26	16	PF1 (HS)/BEEP	I/O	C _T	HS	X	ei1		X	X	Port F1	Beep signal output		
27	17	PF2 (HS)	I/O	C _T	HS	X		ei1		X	X	Port F2		
28	-	PF3/OCMP2_A/AIN9	I/O	C _T		X	X		X	X	X	Port F3	Timer A Output Compare 2	ADC Analog Input 9
29	18	PF4/OCMP1_A/AIN10	I/O	C _T		X	X		X	X	X	Port F4	Timer A Output Compare 1	ADC Analog Input 10
30	-	PF5/ICAP2_A/AIN11	I/O	C _T		X	X		X	X	X	Port F5	Timer A Input Capture 2	ADC Analog Input 11
31	19	PF6(HS)/ICAP1_A	I/O	C _T	HS	X	X			X	X	Port F6	Timer A Input Capture 1	
32	20	PF7(HS)/EXTCLK_A	I/O	C _T	HS	X	X			X	X	Port F7	Timer A External Clock Source	
33	21	V _{DD_0} ⁽¹⁾	S									Digital Main Supply Voltage		
34	22	V _{SS_0} ⁽¹⁾	S									Digital Ground Voltage		
35	23	PC0/OCMP2_B/AIN12	I/O	C _T		X	X		X	X	X	Port C0	Timer B Output Compare 2	ADC Analog Input 12
36	24	PC1/OCMP1_B/AIN13	I/O	C _T		X	X		X	X	X	Port C1	Timer B Output Compare 1	ADC Analog Input 13
37	25	PC2(HS)/ICAP2_B	I/O	C _T	HS	X	X			X	X	Port C2	Timer B Input Capture 2	
38	26	PC3(HS)/ICAP1_B	I/O	C _T	HS	X	X			X	X	Port C3	Timer B Input Capture 1	
39	27	PC4/MISO/ICCDATA	I/O	C _T		X	X			X	X	Port C4	SPI Master In / Slave Out Data	ICC Data Input
40	28	PC5/MOSI/AIN14	I/O	C _T		X	X		X	X	X	Port C5	SPI Master Out / Slave In Data	ADC Analog Input 14

Table 3. Device pin description (continued)

Pin No.		Pin name	Type	Level		Port						Main function (after reset)	Alternate function		
LQFP64	LQFP44			Input	Output	Input				Output					
						float	wpu	int	ana	OD	PP				
41	29	PC6/SCK/ICCCLK	I/O	C _T		X	X				X	X	Port C6	SPI Serial Clock	ICC Clock Output
														Caution: Negative current injection not allowed on this pin (Flash devices only)	
42	30	PC7/ \overline{SS} /AIN15	I/O	C _T		X	X		X	X	X	X	Port C7	SPI Slave Select (active low)	ADC Analog Input 15
43	-	PA0	I/O	C _T		X	ei0			X	X		Port A0		
44	-	PA1	I/O	C _T		X	ei0			X	X		Port A1		
45	-	PA2	I/O	C _T		X	ei0			X	X		Port A2		
46	31	PA3(HS)	I/O	C _T	HS	X		ei0		X	X		Port A3		
47	32	V _{DD_1} ⁽¹⁾	S											Digital Main Supply Voltage	
48	33	V _{SS_1} ⁽¹⁾	S											Digital Ground Voltage	
49	34	PA4(HS)	I/O	C _T	HS	X	X			X	X		Port A4		
50	35	PA5(HS)	I/O	C _T	HS	X	X			X	X		Port A5		
51	36	PA6(HS)/SDAI	I/O	C _T	HS	X				T			Port A6	I ² C Data	
52	37	PA7(HS)/SCLI	I/O	C _T	HS	X				T			Port A7	I ² C Clock	
53	38	V _{PP} / ICCSEL	I											Must be tied low. In Flash programming mode, this pin acts as the programming voltage input V _{PP} . See Section 19.9.2: ICCSEL/VPP pin for more details. High voltage must not be applied to ROM devices.	
54	39	\overline{RESET}	I/O	C _T										Top priority non-maskable interrupt	
55	-	EVD	I	A										External voltage detector	
56	-	TLI	I	C _T				X						Top level interrupt input pin	
57	40	V _{SS_2} ⁽¹⁾	S											Digital Ground Voltage	
58	41	OSC2 ⁽²⁾	I/O											Resonator oscillator inverter output	
59	42	OSC1 ⁽²⁾	I											External clock input or Resonator oscillator inverter input	
60	43	V _{DD_2} ⁽¹⁾	S											Digital Main Supply Voltage	
61	44	PE0/TDO	I/O	C _T		X	X			X	X		Port E0	SCI Transmit Data Out	
62	1	PE1/RDI	I/O	C _T		X	X			X	X		Port E1	SCI Receive Data In	

Table 3. Device pin description (continued)

Pin No.		Pin name	Type	Level		Port						Main function (after reset)	Alternate function
LQFP64	LQFP44			Input	Output	Input				Output			
						float	wpu	int	ana	OD	PP		
63	-	PE2 (Flash device)	I/O	C _T			X					Port E2 Caution: In Flash devices this port is always input with weak pull-up.	
		PE2 (ROM device)				X				X	X	Port E2 Caution: In ROM devices, no weak pull-up present on this port. In LQFP44 this pin is not connected to an internal pull-up like other unbonded pins. It is recommended to configure it as output push-pull to avoid added current consumption.	
64	-	PE3	I/O	C _T		X	X			X	X	Port E3	

- It is mandatory to connect all available V_{DD} and V_{AREF} pins to the supply voltage and all V_{SS} and V_{SSA} pins to ground.
- OSC1 and OSC2 pins connect a crystal/ceramic resonator or an external source to the on-chip oscillator; see [Section 6: Supply, reset and clock management](#) and [Section 19.5: Clock and timing characteristics on page 195](#) for more details.

Legend / Abbreviations for [Table 3](#):

- Type: I = input
O = output
S = supply
- Input level: A = dedicated analog input
- In/Output level: C = CMOS 0.3V_{DD}/0.7V_{DD}
C_T = CMOS 0.3V_{DD}/0.7V_{DD} with input trigger
- Output level: HS = 20mA high sink (on N-buffer only)
- Port and control configuration:
- Input: float = floating
wpu = weak pull-up
int = interrupt^(a)
ana = analog
 - Output: OD = open-drain^(b)
PP = push-pull

a. In the interrupt input column, “eiX” defines the associated external interrupt vector. If the weak pull-up column (wpu) is merged with the interrupt column (int), then the I/O configuration is pull-up interrupt input, otherwise the configuration is floating interrupt input.

b. In the open-drain output column, “T” defines a true open-drain I/O (P-Buffer and protection diode to V_{DD} are not implemented). See [Section 9: I/O ports on page 70](#) and [Section 19.8: I/O port pin characteristics on page 203](#) for more details.

3 Register and memory map

As shown in [Figure 4](#), the MCU is capable of addressing 64 Kbytes of memories and I/O registers.

The available memory locations consist of 128 bytes of register locations, up to 2 Kbytes of RAM and up to 60 Kbytes of user program memory. The RAM space includes up to 256 bytes for the stack from 0100h to 01FFh.

The highest address bytes contain the user reset and interrupt vectors.

IMPORTANT: Memory locations marked as “Reserved” must never be accessed. Accessing a reserved area can have unpredictable effects on the device.

Related documentation

Executing Code in ST7 RAM (AN 985)

Figure 4. Memory map

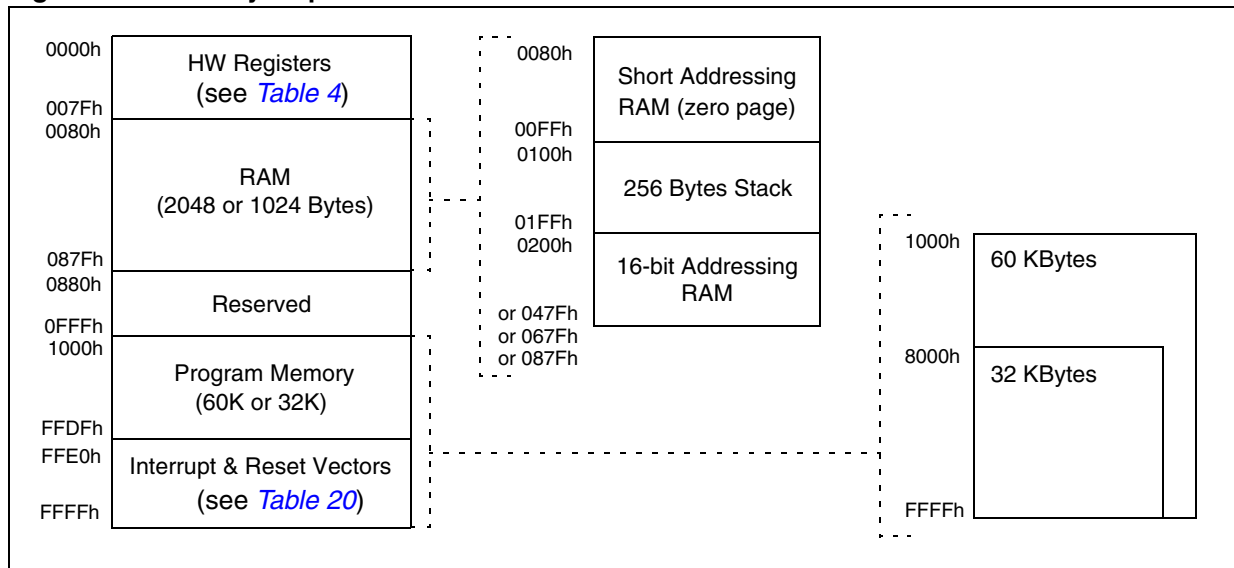

Table 4. Hardware register map

Address	Block	Register label	Register name	Reset status	Remarks
0000h 0001h 0002h	Port A	PADR PADDDR PAOR	Port A Data Register Port A Data Direction Register Port A Option Register	00h ⁽¹⁾ 00h 00h	R/W R/W R/W
0003h 0004h 0005h	Port B	PBDR PBDDR PBOR	Port B Data Register Port B Data Direction Register Port B Option Register	00h ⁽¹⁾ 00h 00h	R/W R/W R/W
0006h 0007h 0008h	Port C	PCDR PCDDR PCOR	Port C Data Register Port C Data Direction Register Port C Option Register	00h ⁽¹⁾ 00h 00h	R/W R/W R/W
0009h 000Ah 000Bh	Port D	PDDR PDDDR PDOR	Port D Data Register Port D Data Direction Register Port D Option Register	00h ⁽¹⁾ 00h 00h	R/W R/W R/W

Table 4. Hardware register map (continued)

Address	Block	Register label	Register name	Reset status	Remarks
000Ch 000Dh 000Eh	Port E	PEDR	Port E Data Register	00h ⁽¹⁾	R/W
		PEDDR	Port E Data Direction Register	00h	R/W ⁽²⁾
		PEOR	Port E Option Register	00h	R/W ⁽²⁾
000Fh 0010h 0011h	Port F	PFDR	Port F Data Register	00h ⁽¹⁾	R/W
		PFDDR	Port F Data Direction Register	00h	R/W
		PFOR	Port F Option Register	00h	R/W
0018h 0019h 001Ah 001Bh 001Ch 001Dh 001Eh	I ² C	I2CCR	I ² C Control Register	00h	R/W
		I2CSR1	I ² C Status Register 1	00h	Read Only
		I2CSR2	I ² C Status Register 2	00h	Read Only
		I2CCCR	I ² C Clock Control Register	00h	R/W
		I2COAR1	I ² C Own Address Register 1	00h	R/W
		I2COAR2	I ² C Own Address Register2	00h	R/W
		I2CDR	I ² C Data Register	00h	R/W
001Fh 0020h	Reserved Area (2 bytes)				
0021h 0022h 0023h	SPI	SPIDR	SPI Data I/O Register	xxh	R/W
		SPICR	SPI Control Register	0xh	R/W
		SPICSR	SPI Control/Status Register	00h	R/W
0024h 0025h 0026h 0027h	ITC	ISPR0	Interrupt Software Priority Register 0	FFh	R/W
		ISPR1	Interrupt Software Priority Register 1	FFh	R/W
		ISPR2	Interrupt Software Priority Register 2	FFh	R/W
		ISPR3	Interrupt Software Priority Register 3	FFh	R/W
0028h		EICR	External Interrupt Control Register	00h	R/W
0029h	FLASH	FCSR	Flash Control/Status Register	00h	R/W
002Ah	WATCHDOG	WDGCR	Watchdog Control Register	7Fh	R/W
002Bh		SICSR	System Integrity Control/Status Register	000x 000x b	R/W
002Ch 002Dh	MCC	MCCSR	Main Clock Control / Status Register	00h	R/W
		MCCBCR	Main Clock Controller: Beep Control Register	00h	R/W
002Eh to 0030h	Reserved Area (3 bytes)				
0031h 0032h 0033h 0034h 0035h 0036h 0037h 0038h 0039h 003Ah 003Bh 003Ch 003Dh 003Eh 003Fh	TIMER A	TACR2	Timer A Control Register 2	00h	R/W
		TACR1	Timer A Control Register 1	00h	R/W
		TACSR	Timer A Control/Status Register	xxxx x0xx b	R/W
		TAIC1HR	Timer A Input Capture 1 High Register	xxh	Read Only
		TAIC1LR	Timer A Input Capture 1 Low Register	xxh	Read Only
		TAOC1HR	Timer A Output Compare 1 High Register	80h	R/W
		TAOC1LR	Timer A Output Compare 1 Low Register	00h	R/W
		TACHR	Timer A Counter High Register	FFh	Read Only
		TACLRL	Timer A Counter Low Register	FCh	Read Only
		TAACHR	Timer A Alternate Counter High Register	FFh	Read Only
		TAACLR	Timer A Alternate Counter Low Register	FCh	Read Only
		TAIC2HR	Timer A Input Capture 2 High Register	xxh	Read Only
		TAIC2LR	Timer A Input Capture 2 Low Register	xxh	Read Only
		TAOC2HR	Timer A Output Compare 2 High Register	80h	R/W
	TAOC2LR	Timer A Output Compare 2 Low Register	00h	R/W	

Table 4. Hardware register map (continued)

Address	Block	Register label	Register name	Reset status	Remarks
0040h	Reserved Area (1 byte)				
0041h	TIMER B	TBCR2	Timer B Control Register 2	00h	R/W
0042h		TBCR1	Timer B Control Register 1	00h	R/W
0043h		TBCSR	Timer B Control/Status Register	xxxx x0xx b	R/W
0044h		TBIC1HR	Timer B Input Capture 1 High Register	xxh	Read Only
0045h		TBIC1LR	Timer B Input Capture 1 Low Register	xxh	Read Only
0046h		TBOC1HR	Timer B Output Compare 1 High Register	80h	R/W
0047h		TBOC1LR	Timer B Output Compare 1 Low Register	00h	R/W
0048h		TBCHR	Timer B Counter High Register	FFh	Read Only
0049h		TBCLR	Timer B Counter Low Register	FCh	Read Only
004Ah		TBACHR	Timer B Alternate Counter High Register	FFh	Read Only
004Bh		TBACLR	Timer B Alternate Counter Low Register	FCh	Read Only
004Ch		TBIC2HR	Timer B Input Capture 2 High Register	xxh	Read Only
004Dh		TBIC2LR	Timer B Input Capture 2 Low Register	xxh	Read Only
004Eh		TBOC2HR	Timer B Output Compare 2 High Register	80h	R/W
004Fh		TBOC2LR	Timer B Output Compare 2 Low Register	00h	R/W
0050h	SCI	SCISR	SCI Status Register	C0h	Read Only
0051h		SCIDR	SCI Data Register	xxh	R/W
0052h		SCIBRR	SCI Baud Rate Register	00h	R/W
0053h		SCICR1	SCI Control Register 1	x000 0000b	R/W
0054h		SCICR2	SCI Control Register 2	00h	R/W
0055h		SCIERPR	SCI Extended Receive Prescaler Register	00h	R/W
0056h			Reserved area	---	
0057h		SCIETPR	SCI Extended Transmit Prescaler Register	00h	R/W
0058h 006Fh	Reserved Area (24 Bytes)				
0070h	ADC	ADCCSR	Control/Status Register	00h	R/W
0071h		ADCDRH	Data High Register	00h	Read Only
0072h		ADCDRL	Data Low Register	00h	Read Only
0073h	PWM ART	PWMDCR3	PWM AR Timer Duty Cycle Register 3	00h	R/W
0074h		PWMDCR2	PWM AR Timer Duty Cycle Register 2	00h	R/W
0075h		PWMDCR1	PWM AR Timer Duty Cycle Register 1	00h	R/W
0076h		PWMDCR0	PWM AR Timer Duty Cycle Register 0	00h	R/W
0077h		PWMCR	PWM AR Timer Control Register	00h	R/W
0078h		ARTCSR	Auto-Reload Timer Control/Status Register	00h	R/W
0079h		ARTCAR	Auto-Reload Timer Counter Access Register	00h	R/W
007Ah		ARTARR	Auto-Reload Timer Auto-Reload Register	00h	R/W
007Bh		ARTICCSR	AR Timer Input Capture Control/Status Reg.	00h	R/W
007Ch		ARTICR1	AR Timer Input Capture Register 1	00h	Read Only
007Dh	ARTICR2	AR Timer Input Capture Register 1	00h	Read Only	
007Eh 007Fh	Reserved Area (2 bytes)				

1. The contents of the I/O port DR registers are readable only in output configuration. In input configuration, the values of the I/O pins are returned instead of the DR register contents.
2. The bits associated with unavailable pins must always keep their reset value.

Note: Legend: x = undefined, R/W = read/write

4 Flash program memory

4.1 Introduction

The ST7 dual voltage High Density Flash (HDFlash) is a non-volatile memory that can be electrically erased as a single block or by individual sectors and programmed on a byte-by-byte basis using an external V_{PP} supply.

The HDFlash devices can be programmed and erased off-board (plugged in a programming tool) or on-board using ICP (in-circuit programming) or IAP (in-application programming).

The array matrix organization allows each sector to be erased and reprogrammed without affecting other sectors.

4.2 Main features

- 3 Flash programming modes:
 - Insertion in a programming tool. In this mode, all sectors including option bytes can be programmed or erased.
 - ICP (in-circuit programming). In this mode, all sectors including option bytes can be programmed or erased without removing the device from the application board.
 - IAP (in-application programming). In this mode, all sectors except Sector 0 can be programmed or erased without removing the device from the application board and while the application is running.
- ICT (in-circuit testing) for downloading and executing user application test patterns in RAM
- Readout protection
- Register Access Security System (RASS) to prevent accidental programming or erasing

4.3 Structure

The Flash memory is organized in sectors and can be used for both code and data storage.

Depending on the overall Flash memory size in the microcontroller device, there are up to three user sectors (see [Table 5](#)). Each of these sectors can be erased independently to avoid unnecessary erasing of the whole Flash memory when only a partial erasing is required.

Table 5. Sectors available in Flash devices

Flash size (bytes)	Available sectors
4K	Sector 0
8K	Sectors 0, 1
> 8K	Sectors 0, 1, 2

The first two sectors have a fixed size of 4 Kbytes (see [Figure 5](#)). They are mapped in the upper part of the ST7 addressing space so the reset and interrupt vectors are located in Sector 0 (F000h-FFFFh).

Figure 5. Memory map and sector address

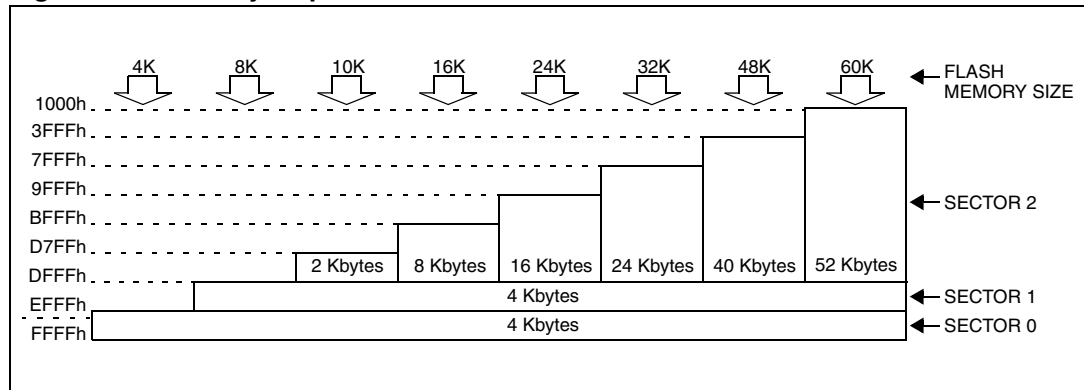

4.3.1 Readout protection

Readout protection, when selected, provides a protection against program memory content extraction and against write access to Flash memory. Even if no protection can be considered as totally unbreakable, the feature provides a very high level of protection for a general purpose microcontroller.

In Flash devices, this protection is removed by reprogramming the option. In this case, the entire program memory is first automatically erased and the device can be reprogrammed.

Note:

4.4 ICC interface

ICC needs a minimum of 4 and up to 6 pins to be connected to the programming tool (see [Figure 6](#)). These pins are:

$\overline{\text{RESET}}$:	device reset
V_{SS} :	device power supply ground
ICCCLK:	ICC output serial clock pin
ICCDATA:	ICC input/output serial data pin
ICCSEL/ V_{PP} :	programming voltage
OSC1 (or OSCIN):	main clock input for external source (optional)
V_{DD} :	application board power supply (optional, see Figure 6, Note 3)

Figure 6. Typical ICC interface

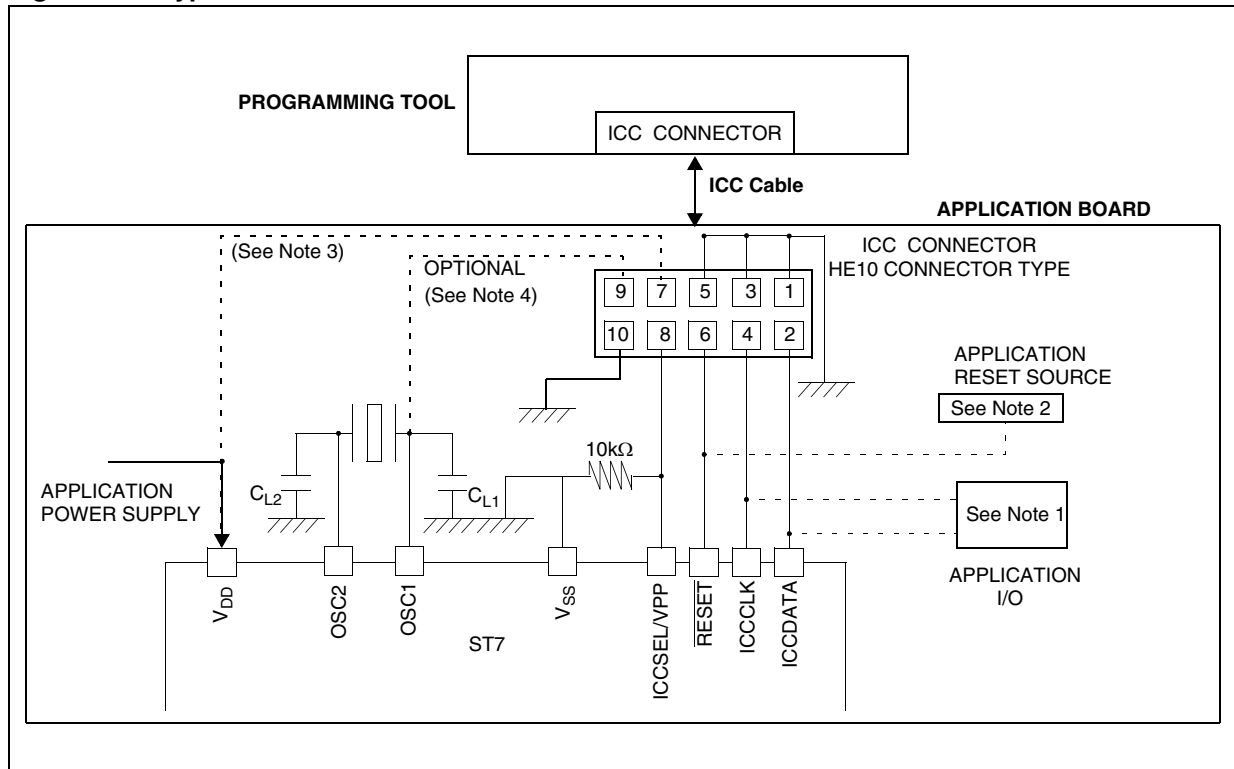

1. If the ICCCLK or ICCDATA pins are only used as outputs in the application, no signal isolation is necessary. As soon as the programming tool is plugged to the board, even if an ICC session is not in progress, the ICCCLK and ICCDATA pins are not available for the application. If they are used as inputs by the application, isolation such as a serial resistor has to be implemented in case another device forces the signal. Refer to the programming tool documentation for recommended resistor values.
2. During the ICC session, the programming tool must control the $\overline{\text{RESET}}$ pin. This can lead to conflicts between the programming tool and the application reset circuit if it drives more than 5mA at high level (push-pull output or pull-up resistor < 1K). A schottky diode can be used to isolate the application RESET circuit in this case. When using a classical RC network with $R > 1K$ or a reset management IC with open-drain output and pull-up resistor > 1K, no additional components are needed. In all cases the user must ensure that no external reset is generated by the application during the ICC session.
3. The use of Pin 7 of the ICC connector depends on the programming tool architecture. This pin must be connected when using most ST programming tools (it is used to monitor the application power supply). Please refer to the programming tool manual.
4. Pin 9 has to be connected to the OSC1 or OSCIN pin of the ST7 when the clock is not available in the application or if the selected clock option is not programmed in the option byte. ST7 devices with multi-oscillator capability need to have OSC2 grounded in this case.

4.5 ICP (in-circuit programming)

To perform ICP the microcontroller must be switched to ICC (in-circuit communication) mode by an external controller or programming tool.

Depending on the ICP code downloaded in RAM, Flash memory programming can be fully customized (number of bytes to program, program locations, or selection serial communication interface for downloading).

When using an STMicroelectronics or third-party programming tool that supports ICP and the specific microcontroller device, the user needs only to implement the ICP hardware interface on the application board (see [Figure 6](#)). For more details on the pin locations, refer to the device pinout description.

4.6 IAP (in-application programming)

This mode uses a BootLoader program previously stored in Sector 0 by the user (in ICP mode or by plugging the device in a programming tool).

This mode is fully controlled by user software. This allows it to be adapted to the user application, (such as user-defined strategy for entering programming mode, choice of communications protocol used to fetch the data to be stored). For example, it is possible to download code from the interface and program it in the Flash. IAP mode can be used to program any of the Flash sectors except Sector 0, which is write/erase protected to allow recovery in case errors occur during the programming operation.

4.7 Related documentation

For details on Flash programming and ICC protocol, refer to the *ST7 Flash Programming Reference Manual* and to the *ST7 ICC Protocol Reference Manual*.

4.8 Flash control/status register (FCSR)

FCSR				Reset value: 0000 0000 (00h)			
7	6	5	4	3	2	1	0
0	0	0	0	0	0	0	0
RW	RW	RW	RW	RW	RW	RW	RW

This register is reserved for use by programming tool software. It controls the Flash programming and erasing operations.

Table 6. Flash control/status register address and reset value

Address (Hex.)	Register label	7	6	5	4	3	2	1	0
0029h	FCSR Reset value	0	0	0	0	0	0	0	0

5 Central processing unit (CPU)

5.1 Introduction

This CPU has a full 8-bit architecture and contains six internal registers allowing efficient 8-bit data manipulation.

5.2 Main features

- Enable executing 63 basic instructions
- Fast 8-bit by 8-bit multiply
- 17 main addressing modes (with indirect addressing mode)
- Two 8-bit index registers
- 16-bit stack pointer
- Low power Halt and Wait modes
- Priority maskable hardware interrupts
- Non-maskable software/hardware interrupts

5.3 CPU registers

The six CPU registers shown in [Figure 7](#) are not present in the memory mapping and are accessed by specific instructions.

Figure 7. CPU registers

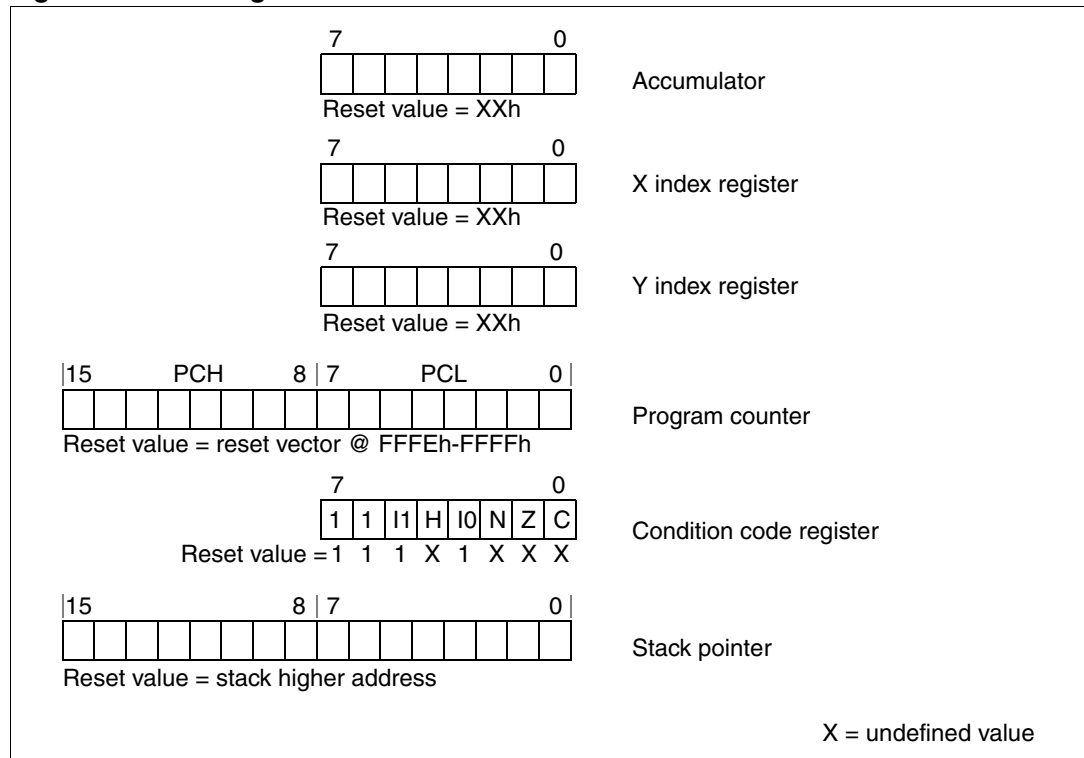

5.3.1 Accumulator (A)

The accumulator is an 8-bit general purpose register used to hold operands and the results of the arithmetic and logic calculations as well as data manipulations.

5.3.2 Index registers (X and Y)

These 8-bit registers are used to create effective addresses or as temporary storage areas for data manipulation (the Cross-Assembler generates a precede instruction (PRE) to indicate that the following instruction refers to the Y register.)

The Y register is not affected by the interrupt automatic procedures.

5.3.3 Program counter (PC)

The program counter is a 16-bit register containing the address of the next instruction to be executed by the CPU. It is made of two 8-bit registers PCL (Program Counter Low which is the LSB) and PCH (Program Counter High which is the MSB).

5.3.4 Condition code (CC) register

The 8-bit condition code register contains the interrupt masks and four flags representative of the result of the instruction just executed. This register can also be handled by the PUSH and POP instructions.

These bits can be individually tested and/or controlled by specific instructions.

CC	Reset value: 111x1xxx						
7	6	5	4	3	2	1	0
1	1	I1	H	I0	N	Z	C
		RW	RW	RW	RW	RW	RW

Table 7. Arithmetic management bits

Bit	Name	Function
4	H	<p><i>Half carry</i></p> <p>This bit is set by hardware when a carry occurs between bits 3 and 4 of the ALU during an ADD or ADC instructions. It is reset by hardware during the same instructions.</p> <p>0: No half carry has occurred. 1: A half carry has occurred.</p> <p>This bit is tested using the JRH or JRNH instruction. The H bit is useful in BCD arithmetic subroutines.</p>
2	N	<p><i>Negative</i></p> <p>This bit is set and cleared by hardware. It is representative of the result sign of the last arithmetic, logical or data manipulation. It is a copy of the result 7th bit.</p> <p>0: The result of the last operation is positive or null. 1: The result of the last operation is negative (that is, the most significant bit is a logic 1).</p> <p>This bit is accessed by the JRMI and JRPL instructions.</p>

Table 7. Arithmetic management bits (continued)

Bit	Name	Function
1	Z	<i>Zero</i> This bit is set and cleared by hardware. This bit indicates that the result of the last arithmetic, logical or data manipulation is zero. 0: The result of the last operation is different from zero. 1: The result of the last operation is zero. This bit is accessed by the JREQ and JRNE test instructions.
0	C	<i>Carry/borrow</i> This bit is set and cleared by hardware and software. It indicates an overflow or an underflow has occurred during the last arithmetic operation. 0: No overflow or underflow has occurred. 1: An overflow or underflow has occurred. This bit is driven by the SCF and RCF instructions and tested by the JRC and JRNC instructions. It is also affected by the “bit test and branch”, shift and rotate instructions.

Table 8. Interrupt management bits

Bit	Name	Function
5	I1	<i>Interrupt Software Priority 1</i> The combination of the I1 and I0 bits gives the current interrupt software priority.
3	I0	<i>Interrupt Software Priority 0</i> The combination of the I1 and I0 bits gives the current interrupt software priority.

Table 9. Interrupt software priority selection

Interrupt software priority	Level	I1	I0
Level 0 (main)	Low	1	0
Level 1	↓	0	1
Level 2		0	0
Level 3 (= interrupt disable)	High	1	1

These two bits are set/cleared by hardware when entering in interrupt. The loaded value is given by the corresponding bits in the interrupt software priority registers (ISPRx). They can be also set/cleared by software with the RIM, SIM, IRET, HALT, WFI and PUSH/POP instructions.

See [Chapter 7: Interrupts on page 49](#) for more details.

5.3.5 Stack pointer (SP) register

SP															Reset value: 01 FFh
15	14	13	12	11	10	9	8	7	6	5	4	3	2	1	0
0	0	0	0	0	0	0	1	SP7	SP6	SP5	SP4	SP3	SP2	SP1	SP0
								RW	RW	RW	RW	RW	RW	RW	RW

The stack pointer is a 16-bit register which is always pointing to the next free location in the stack. It is then decremented after data has been pushed onto the stack and incremented before data is popped from the stack (see *Figure 8*).

Since the stack is 256 bytes deep, the 8 most significant bits are forced by hardware. Following an MCU Reset, or after a reset stack pointer instruction (RSP), the stack pointer contains its reset value (the SP7 to SP0 bits are set) which is the stack higher address.

The least significant byte of the stack pointer (called S) can be directly accessed by an LD instruction.

Note: When the lower limit is exceeded, the stack pointer wraps around to the stack upper limit, without indicating the stack overflow. The previously stored information is then overwritten and therefore lost. The stack also wraps in case of an underflow.

The stack is used to save the return address during a subroutine call and the CPU context during an interrupt. The user may also directly manipulate the stack by means of the PUSH and POP instructions. In the case of an interrupt, the PCL is stored at the first location pointed to by the SP. The other registers are then stored in the next locations as shown in *Figure 8*.

- When an interrupt is received, the SP is decremented and the context is pushed on the stack.
- On return from interrupt, the SP is incremented and the context is popped from the stack.

A subroutine call occupies two locations and an interrupt five locations in the stack area.

Figure 8. Stack manipulation example

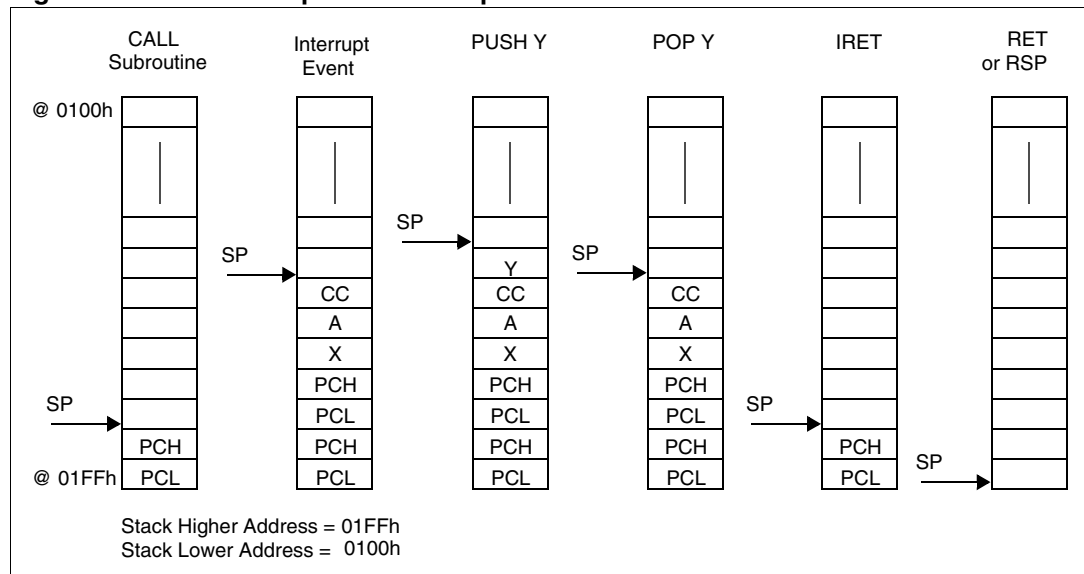

6 Supply, reset and clock management

6.1 Introduction

The device includes a range of utility features for securing the application in critical situations (for example in case of a power brown-out), and reducing the number of external components. An overview is shown in [Figure 9](#).

For more details, refer to the dedicated parametric section.

6.2 Main features

- Optional PLL for multiplying the frequency by 2 (not to be used with internal RC oscillator)
- Reset Sequence Manager (RSM)
- Multi-oscillator Clock Management (MO)
 - 5 crystal/ceramic resonator oscillators
 - 1 internal RC oscillator
- System Integrity Management (SI)
 - Main supply low voltage detection (LVD)
 - Auxiliary voltage detector (AVD) with interrupt capability for monitoring the main supply or the EVD pin

Figure 9. Clock, reset and supply block diagram

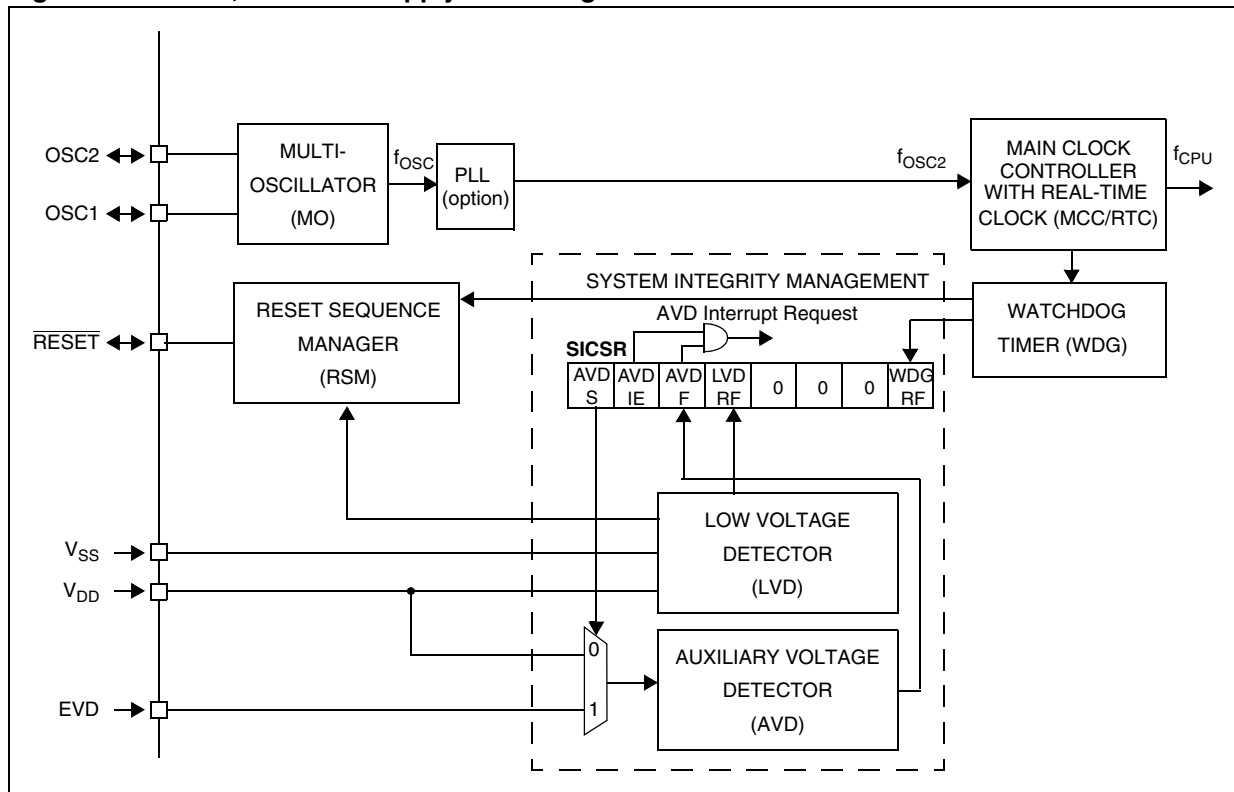

6.3 Phase locked loop

If the clock frequency input to the PLL is in the range 2 to 4 MHz, the PLL can be used to multiply the frequency by two to obtain an f_{OSC2} of 4 to 8 MHz. The PLL is enabled by option byte. If the PLL is disabled, then $f_{OSC2} = f_{OSC}/2$.

Caution: The PLL is not recommended for applications where timing accuracy is required (see [Section 19.5.5: PLL characteristics on page 198](#)).

Figure 10. PLL block diagram

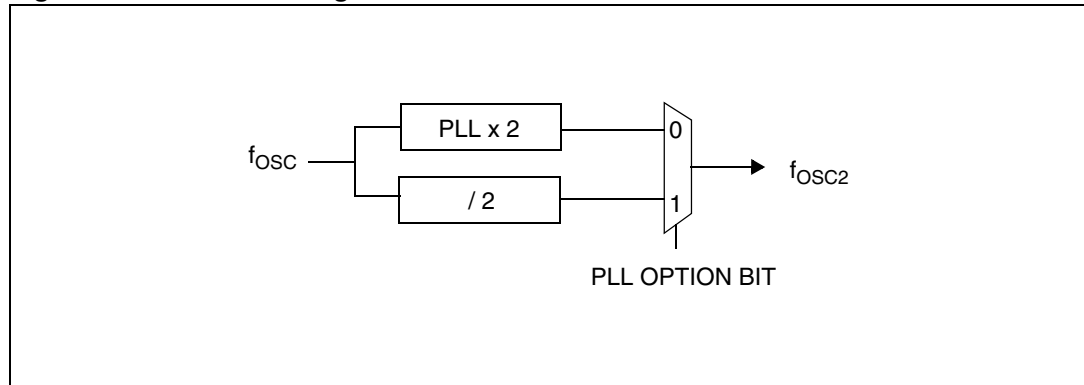

6.4 Multi-oscillator (MO)

The main clock of the ST7 can be generated by three different source types coming from the multi-oscillator block:

- an external source
- 4 crystal or ceramic resonator oscillators
- an internal high frequency RC oscillator

Each oscillator is optimized for a given frequency range in terms of consumption and is selectable through the option byte. The associated hardware configurations are shown in [Table 10](#). Refer to [Section 19: Electrical characteristics](#) for more details.

Caution: The OSC1 and/or OSC2 pins must not be left unconnected. For the purposes of Failure Mode and Effect Analysis, it should be noted that if the OSC1 and/or OSC2 pins are left unconnected, the ST7 main oscillator may start and, in this configuration, could generate an f_{OSC} clock frequency in excess of the allowed maximum (> 16 MHz), putting the ST7 in an unsafe/undefined state. The product behavior must therefore be considered undefined when the OSC pins are left unconnected.

External clock source

In this external clock mode, a clock signal (square, sinus or triangle) with ~50% duty cycle has to drive the OSC1 pin while the OSC2 pin is tied to ground.

Crystal/ceramic oscillators

This family of oscillators has the advantage of producing a very accurate rate on the main clock of the ST7. The selection within a list of four oscillators with different frequency ranges has to be done by option byte in order to reduce consumption (refer to [Section 21.1.1: Flash configuration on page 223](#) for more details on the frequency ranges). In this mode of the multi-oscillator, the resonator and the load capacitors have to be placed as close as possible to the oscillator pins in order to minimize output distortion and start-up stabilization time. The loading capacitance values must be adjusted according to the selected oscillator.

These oscillators are not stopped during the RESET phase to avoid losing time in the oscillator start-up phase.

Internal RC oscillator

This oscillator allows a low cost solution for the main clock of the ST7 using only an internal resistor and capacitor. Internal RC oscillator mode has the drawback of a lower frequency accuracy and should not be used in applications that require accurate timing.

In this mode, the two oscillator pins have to be tied to ground.

Table 10. ST7 clock sources

Hardware configuration	
External clock	
Crystal/Ceramic resonators	
Internal RC oscillator	

6.5 Reset sequence manager (RSM)

6.5.1 Introduction

The reset sequence manager includes three RESET sources as shown in [Figure 11](#):

- External RESET source pulse
- Internal LVD RESET (low voltage detection)
- Internal WATCHDOG RESET

These sources act on the $\overline{\text{RESET}}$ pin and it is always kept low during the delay phase.

The RESET service routine vector is fixed at addresses FFFEh-FFFFh in the ST7 memory map.

The basic RESET sequence consists of three phases as shown in [Figure 12](#):

- Active phase depending on the RESET source
- 256 or 4096 CPU clock cycle delay (selected by option byte)
- RESET vector fetch

Caution: When the ST7 is unprogrammed or fully erased, the Flash is blank and the RESET vector is not programmed. For this reason, it is recommended to keep the $\overline{\text{RESET}}$ pin in low state until programming mode is entered, in order to avoid unwanted behavior.

The 256 or 4096 CPU clock cycle delay allows the oscillator to stabilize and ensures that recovery has taken place from the Reset state. The shorter or longer clock cycle delay should be selected by option byte to correspond to the stabilization time of the external oscillator used in the application (see [Section 21.1.1: Flash configuration on page 223](#)).

The RESET vector fetch phase duration is 2 clock cycles.

Figure 11. Reset block diagram

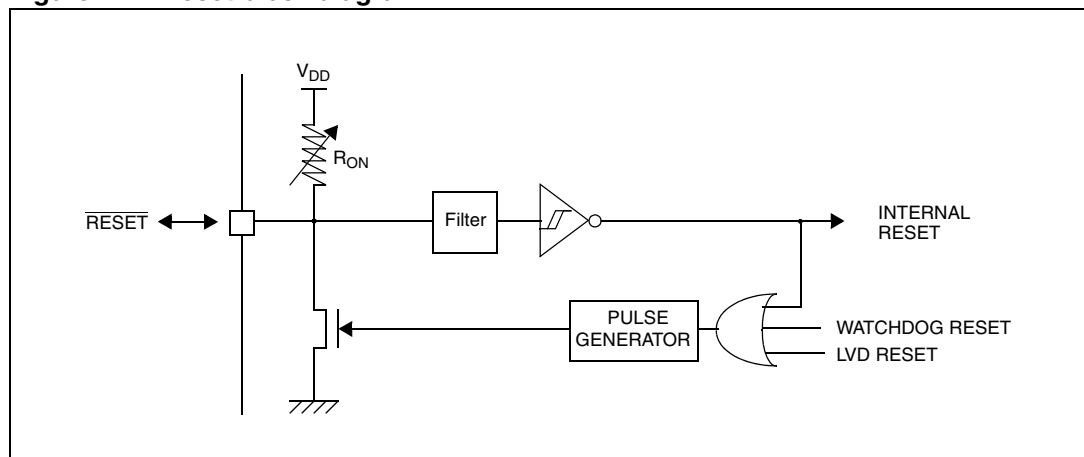
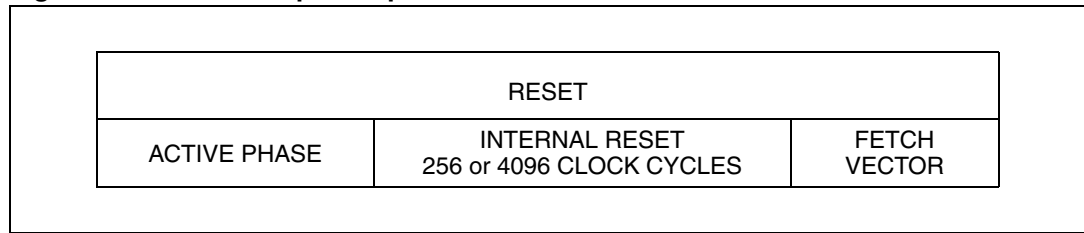

Figure 12. RESET sequence phases



6.5.2 Asynchronous external $\overline{\text{RESET}}$ pin

The $\overline{\text{RESET}}$ pin is both an input and an open-drain output with integrated R_{ON} weak pull-up resistor. This pull-up has no fixed value but varies in accordance with the input voltage. It can be pulled low by external circuitry to reset the device. See [Section 19.9: Control pin characteristics on page 207](#) for more details.

A RESET signal originating from an external source must have a duration of at least $t_{\text{h(RSTL)}}_{\text{in}}$ in order to be recognized (see [Figure 13](#)). This detection is asynchronous and therefore the MCU can enter reset state even in Halt mode.

The $\overline{\text{RESET}}$ pin is an asynchronous signal which plays a major role in EMS performance. In a noisy environment, it is recommended to follow the guidelines mentioned in [Section 19: Electrical characteristics](#).

If the external $\overline{\text{RESET}}$ pulse is shorter than $t_{\text{w(RSTL)}}_{\text{out}}$ (see short ext. Reset in [Figure 13](#)), the signal on the $\overline{\text{RESET}}$ pin may be stretched. Otherwise the delay will not be applied (see long ext. Reset in [Figure 13](#)). Starting from the external RESET pulse recognition, the device $\overline{\text{RESET}}$ pin acts as an output that is pulled low during at least $t_{\text{w(RSTL)}}_{\text{out}}$.

6.5.3 External power-on RESET

If the LVD is disabled by option byte, to start up the microcontroller correctly, the user must ensure by means of an external reset circuit that the reset signal is held low until V_{DD} is over the minimum level specified for the selected f_{OSC} frequency (see [Section 19.3: Operating conditions on page 188](#)).

A proper reset signal for a slow rising V_{DD} supply can generally be provided by an external RC network connected to the $\overline{\text{RESET}}$ pin.

6.5.4 Internal low voltage detector (LVD) RESET

Two different RESET sequences caused by the internal LVD circuitry can be distinguished:

- Power-on RESET
- Voltage drop RESET

The device $\overline{\text{RESET}}$ pin acts as an output that is pulled low when $V_{\text{DD}} < V_{\text{IT+}}$ (rising edge) or $V_{\text{DD}} < V_{\text{IT-}}$ (falling edge) as shown in [Figure 13](#).

The LVD filters spikes on V_{DD} larger than $t_{\text{g(VDD)}}$ to avoid parasitic resets.

6.5.5 Internal watchdog RESET

The RESET sequence generated by an internal Watchdog counter overflow is shown in [Figure 13](#).

Starting from the Watchdog counter underflow, the device $\overline{\text{RESET}}$ pin acts as an output that is pulled low during at least $t_{w(\text{RSTL})\text{out}}$.

Figure 13. RESET sequences

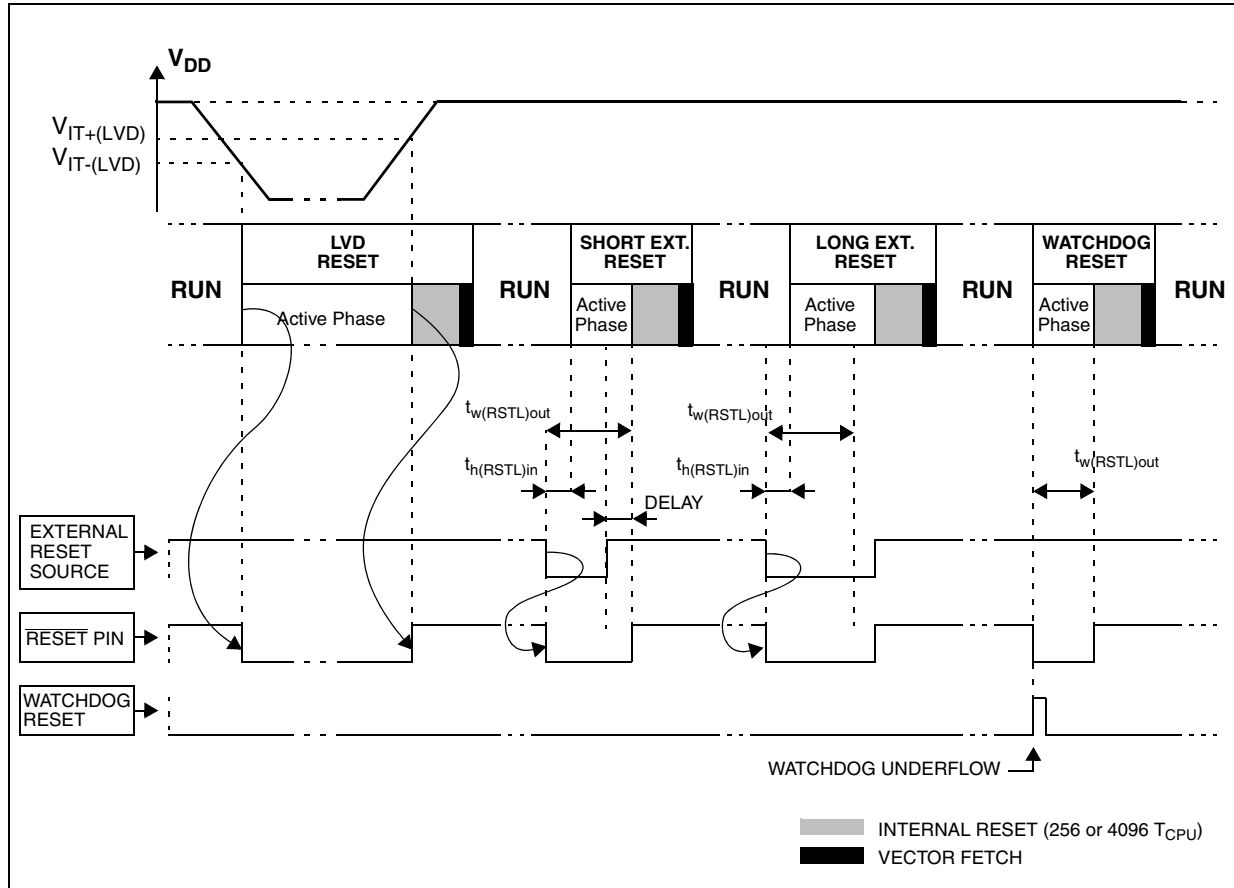

6.6 System integrity management (SI)

The System Integrity Management block contains the Low Voltage Detector (LVD) and Auxiliary Voltage Detector (AVD) functions. It is managed by the SICSR register.

6.6.1 Low voltage detector (LVD)

The low voltage detector function (LVD) generates a static reset when the V_{DD} supply voltage is below a V_{IT-} reference value. This means that it secures the power-up as well as the power-down keeping the ST7 in reset.

The V_{IT-} reference value for a voltage drop is lower than the V_{IT+} reference value for power-on in order to avoid a parasitic reset when the MCU starts running and sinks current on the supply (hysteresis).

The LVD reset circuitry generates a reset when V_{DD} is below:

- V_{IT+} when V_{DD} is rising
- V_{IT-} when V_{DD} is falling

The LVD function is illustrated in [Figure 14](#).

The voltage threshold can be configured by option byte to be low, medium or high.

Provided the minimum V_{DD} value (guaranteed for the oscillator frequency) is above V_{IT-} , the MCU can only be in two modes:

- under full software control
- in static safe reset

In these conditions, secure operation is always ensured for the application without the need for external reset hardware.

During a low voltage detector reset, the \overline{RESET} pin is held low, thus permitting the MCU to reset other devices.

Note: The LVD allows the device to be used without any external RESET circuitry.

If the medium or low thresholds are selected, the detection may occur outside the specified operating voltage range. Below 3.8V, device operation is not guaranteed.

The LVD is an optional function which can be selected by option byte.

It is recommended to make sure that the V_{DD} supply voltage rises monotonously when the device is exiting from Reset, to ensure the application functions properly.

Figure 14. Low voltage detector versus reset

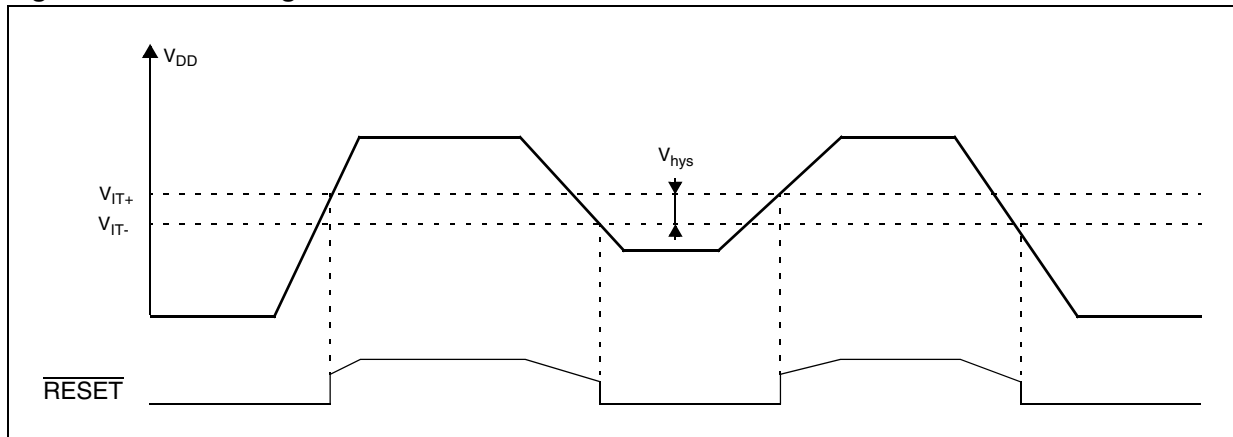

6.6.2 Auxiliary voltage detector (AVD)

The auxiliary voltage detector function (AVD) is based on an analog comparison between a $V_{IT-(AVD)}$ and $V_{IT+(AVD)}$ reference value and the V_{DD} main supply or the external EVD pin voltage level (V_{EVD}). The V_{IT-} reference value for falling voltage is lower than the V_{IT+} reference value for rising voltage in order to avoid parasitic detection (hysteresis).

The output of the AVD comparator can be read directly by the application software through a real-time status bit (AVDF) in the SICSR register. This bit is read only.

Caution: The AVD function is active only if the LVD is enabled through the option byte.

Monitoring the V_{DD} main supply

This mode is selected by clearing the AVDS bit in the SICSR register.

The AVD voltage threshold value is relative to the selected LVD threshold configured by option byte (see [Section 21.1.1: Flash configuration on page 223](#)).

If the AVD interrupt is enabled, an interrupt is generated when the voltage crosses the $V_{IT+(AVD)}$ or $V_{IT-(AVD)}$ threshold (AVDF bit toggles).

In the case of a drop in voltage, the AVD interrupt acts as an early warning, allowing software to shut down safely before the LVD resets the microcontroller. See [Figure 15](#).

The interrupt on the rising edge is used to inform the application that the V_{DD} warning state is over.

If the voltage rise time t_{rV} is less than 256 or 4096 CPU cycles (depending on the reset delay selected by option byte), no AVD interrupt will be generated when $V_{IT+(AVD)}$ is reached.

If t_{rV} is greater than 256 or 4096 cycles

- two AVD interrupts will be received if the AVD interrupt is enabled **before** the $V_{IT+(AVD)}$ threshold is reached: the first when the AVDIE bit is set, and the second when the threshold is reached.
- only one AVD interrupt will occur if the AVD interrupt is enabled **after** the $V_{IT+(AVD)}$ threshold is reached.

Figure 15. Using the AVD to monitor V_{DD} (AVDS bit = 0)

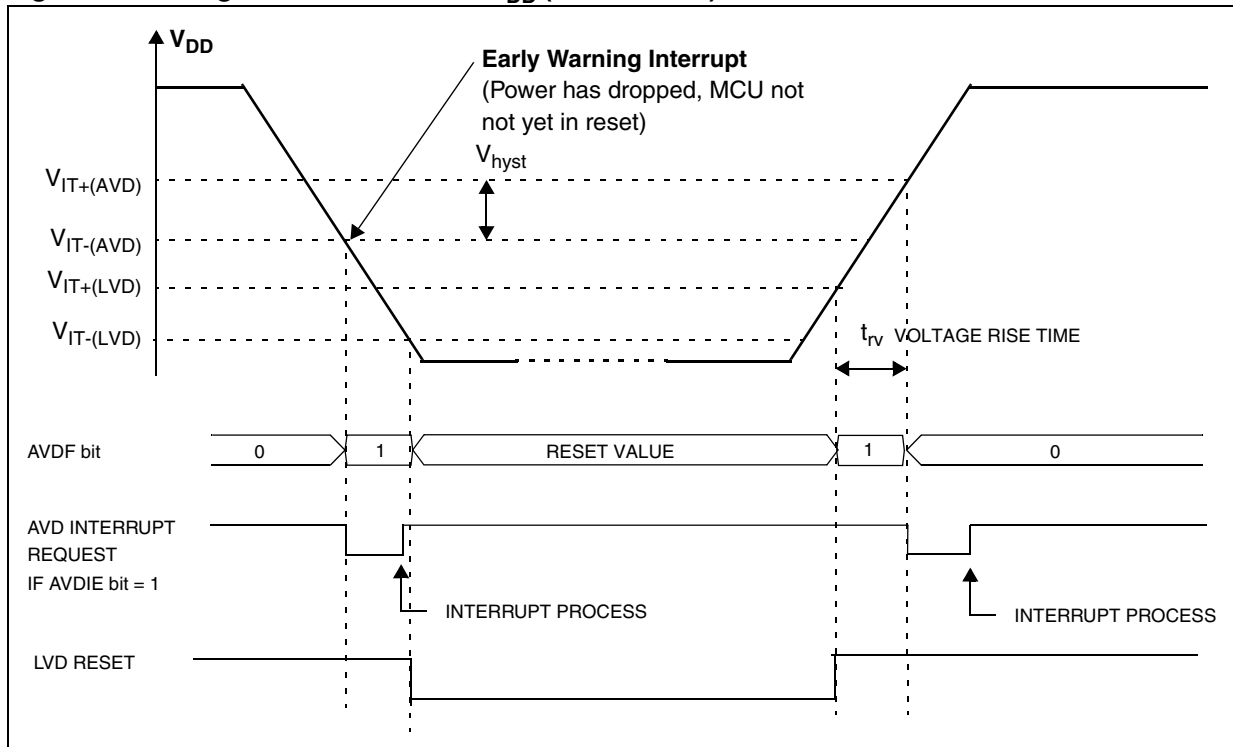

Monitoring a voltage on the EVD pin

This mode is selected by setting the AVDS bit in the SICSR register.

The AVD circuitry can generate an interrupt when the AVDIE bit of the SICSR register is set. This interrupt is generated on the rising and falling edges of the comparator output. This means it is generated when either one of these two events occur:

- V_{EVD} rises up to $V_{IT+(EVD)}$
- V_{EVD} falls down to $V_{IT-(EVD)}$

The EVD function is illustrated in [Figure 16](#).

For more details, refer to [Section 19: Electrical characteristics](#).

Figure 16. Using the voltage detector to monitor the EVD pin (AVDS bit = 1)

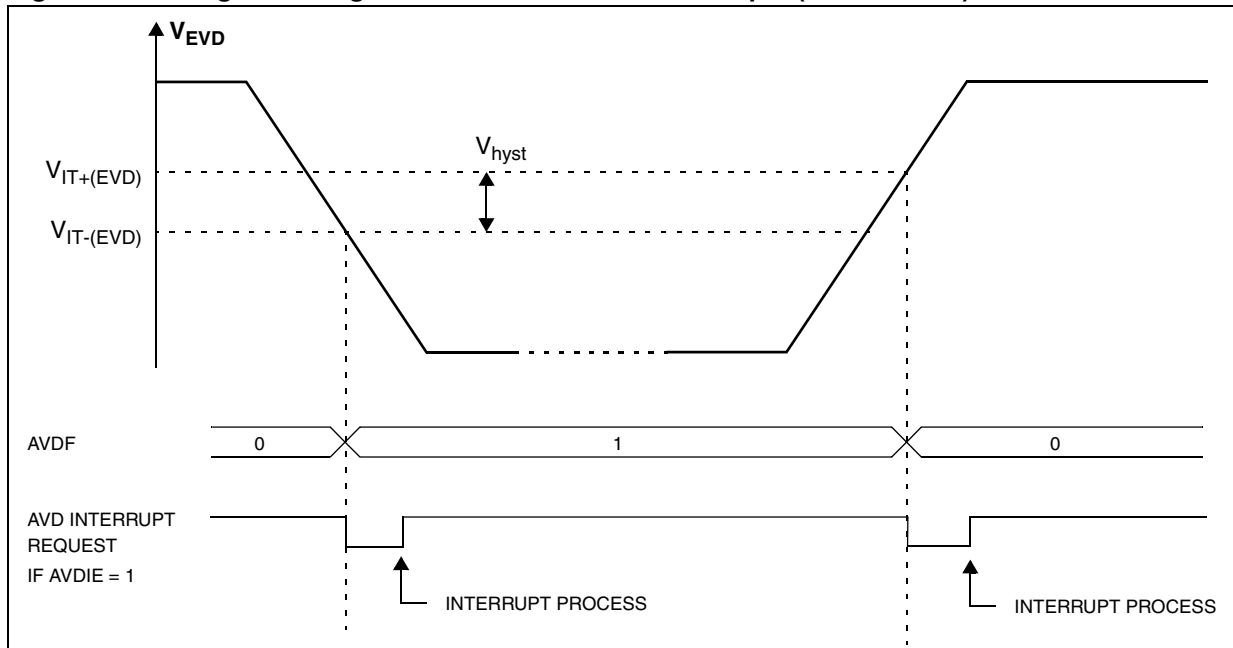

6.6.3 Low power modes

Table 11. Effect of low power modes on SI

Mode	Effect
Wait	No effect on SI. AVD interrupts cause the device to exit from Wait mode.
Halt	The SICSR register is frozen.

6.6.4 Interrupts

The AVD interrupt event generates an interrupt if the corresponding Enable Control Bit (AVDIE) is set and the interrupt mask in the CC register is reset (RIM instruction).

Table 12. AVD interrupt control/wake-up capability

Interrupt event	Event flag	Enable control bit	Exit from Wait	Exit from Halt
AVD event	AVDF	AVDIE	Yes	No

6.6.5 System Integrity (SI) Control/Status register (SICSR)

SICSR Reset value: 000x 000x (00h)

7	6	5	4	3	2	1	0
AVDS	AVDIE	AVDF	LVDRF	Reserved			WDGRF
RW	RW	RW	RW	-			RW

Table 13. SICSR description

Bit	Name	Function
7	AVDS	<p><i>Voltage Detection selection</i></p> <p>This bit is set and cleared by software. Voltage Detection is available only if the LVD is enabled by option byte.</p> <p>0: Voltage detection on V_{DD} supply 1: Voltage detection on EVD pin</p>
6	AVDIE	<p><i>Voltage Detector interrupt enable</i></p> <p>This bit is set and cleared by software. It enables an interrupt to be generated when the AVDF flag changes (toggles). The pending interrupt information is automatically cleared when software enters the AVD interrupt routine.</p> <p>0: AVD interrupt disabled 1: AVD interrupt enabled</p>
5	AVDF	<p><i>Voltage Detector flag</i></p> <p>This read-only bit is set and cleared by hardware. If the AVDIE bit is set, an interrupt request is generated when the AVDF bit changes value. Refer to Figure 15 and to Monitoring the VDD main supply on page 44 for additional details.</p> <p>0: V_{DD} or V_{EVD} over V_{IT+(AVD)} threshold 1: V_{DD} or V_{EVD} under V_{IT-(AVD)} threshold</p>
4	LVDRF	<p><i>LVD reset flag</i></p> <p>This bit indicates that the last Reset was generated by the LVD block. It is set by hardware (LVD reset) and cleared by software (writing zero). See Table 14: Reset source flags for more details. When the LVD is disabled by OPTION BYTE, the LVDRF bit value is undefined.</p>
3:1	-	Reserved, must be kept cleared.
0	WDGRF	<p><i>Watchdog reset flag</i></p> <p>This bit indicates that the last Reset was generated by the Watchdog peripheral. It is set by hardware (watchdog reset) and cleared by software (writing zero) or an LVD Reset (to ensure a stable cleared state of the WDGRF flag when CPU starts). Combined with the LVDRF flag information, the flag description is given in Table 14.</p>

Table 14. Reset source flags

Reset sources	LVDRF	WDGRF
External RESET pin	0	0
Watchdog	0	1
LVD	1	X

Application notes

The LVDRF flag is not cleared when another RESET type occurs (external or watchdog); the LVDRF flag remains set to keep trace of the original failure.

In this case, software can detect a watchdog reset but cannot detect an external reset.

Caution: When the LVD is not activated with the associated option byte, the WDGRF flag cannot be used in the application.

7 Interrupts

7.1 Introduction

The ST7 enhanced interrupt management provides the following features:

- Hardware interrupts
- Software interrupt (TRAP)
- Nested or concurrent interrupt management with flexible interrupt priority and level management:
 - Up to 4 software programmable nesting levels
 - Up to 16 interrupt vectors fixed by hardware
 - 2 non-maskable events: RESET, TRAP
 - 1 maskable Top Level event: TLI

This interrupt management is based on:

- Bit 5 and bit 3 of the CPU CC register (I1:0)
- Interrupt software priority registers (ISPRx)
- Fixed interrupt vector addresses located at the high addresses of the memory map (FFE0h to FFFFh) sorted by hardware priority order

This enhanced interrupt controller guarantees full upward compatibility with the standard (not nested) ST7 interrupt controller.

7.2 Masking and processing flow

The interrupt masking is managed by the I1 and I0 bits of the CC register and the ISPRx registers which give the interrupt software priority level of each interrupt vector (see [Table 15](#)). The processing flow is shown in [Figure 17](#).

When an interrupt request has to be serviced:

- Normal processing is suspended at the end of the current instruction execution.
- The PC, X, A and CC registers are saved onto the stack.
- I1 and I0 bits of CC register are set according to the corresponding values in the ISPRx registers of the serviced interrupt vector.
- The PC is then loaded with the interrupt vector of the interrupt to service and the first instruction of the interrupt service routine is fetched (refer to [Table 20: Interrupt mapping](#) for vector addresses).

The interrupt service routine should end with the IRET instruction which causes the contents of the saved registers to be recovered from the stack.

Note: As a consequence of the IRET instruction, the I1 and I0 bits will be restored from the stack and the program in the previous level will resume.

Table 15. Interrupt software priority levels

Interrupt software priority	Level	I1	I0
Level 0 (main)	Low ↓ High	1	0
Level 1		0	1
Level 2		0	0
Level 3 (= interrupt disable)		1	1

Figure 17. Interrupt processing flowchart

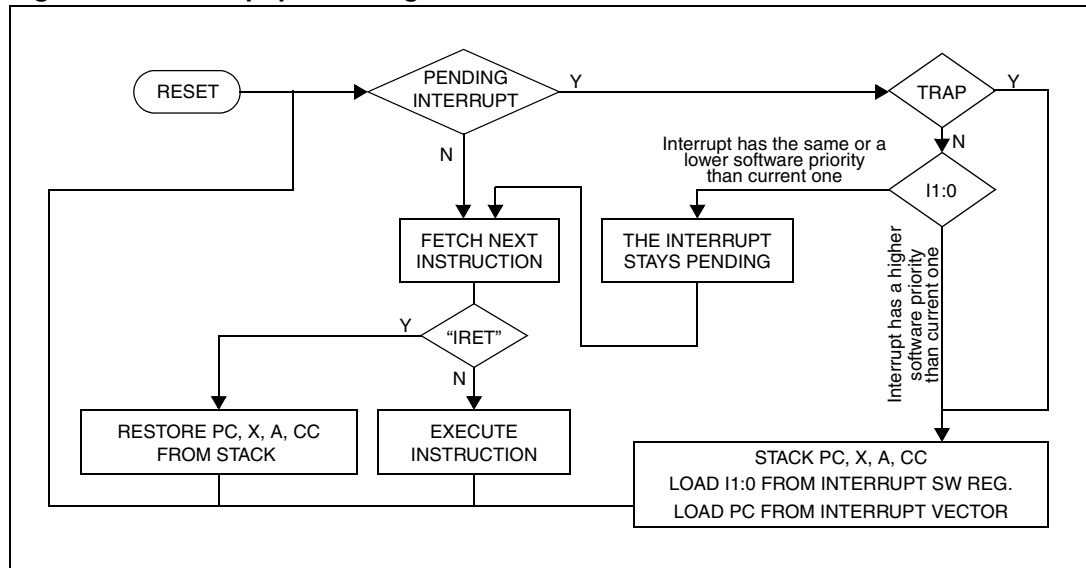

Servicing pending interrupts

As several interrupts can be pending at the same time, the interrupt to be taken into account is determined by the following two-step process:

- the highest software priority interrupt is serviced,
- if several interrupts have the same software priority then the interrupt with the highest hardware priority is serviced first.

Figure 18 describes this decision process.

Figure 18. Priority decision process flowchart

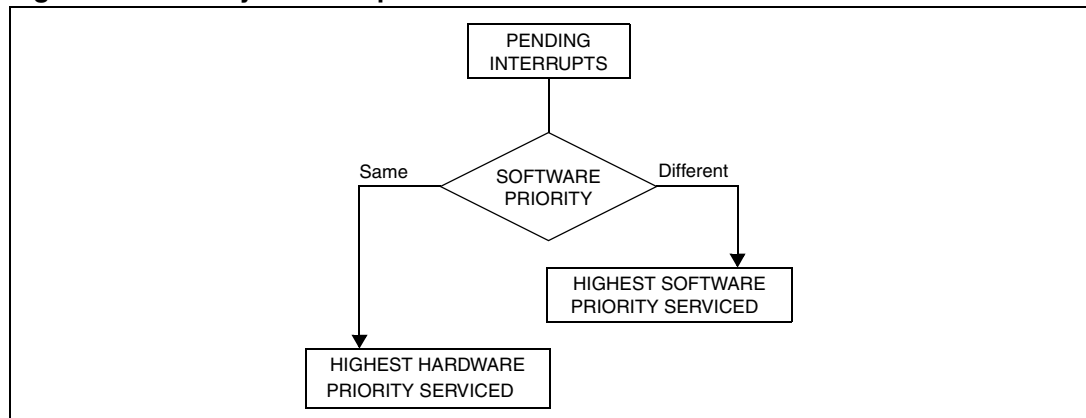

When an interrupt request is not serviced immediately, it is latched and then processed when its software priority combined with the hardware priority becomes the highest one.

- Note:**
- 1 *The hardware priority is exclusive while the software one is not. This allows the previous process to succeed with only one interrupt.*
 - 2 *TLI, RESET and TRAP can be considered as having the highest software priority in the decision process.*

Different interrupt vector sources

Two interrupt source types are managed by the ST7 interrupt controller: the non-maskable type (RESET, TRAP) and the maskable type (external or from internal peripherals).

Non-maskable sources

These sources are processed regardless of the state of the I1 and I0 bits of the CC register (see [Figure 17](#)). After stacking the PC, X, A and CC registers (except for RESET), the corresponding vector is loaded in the PC register and the I1 and I0 bits of the CC are set to disable interrupts (level 3). These sources allow the processor to exit Halt mode.

- TRAP (non-maskable software interrupt)
This software interrupt is serviced when the TRAP instruction is executed. It will be serviced according to the flowchart in [Figure 17](#).

Caution: TRAP can be interrupted by a TLI.

- RESET
The RESET source has the highest priority in the ST7. This means that the first current routine has the highest software priority (level 3) and the highest hardware priority.
See [Section 6.5: Reset sequence manager \(RSM\) on page 40](#) for more details.

Maskable sources

Maskable interrupt vector sources can be serviced if the corresponding interrupt is enabled and if its own interrupt software priority (in ISPRx registers) is higher than the one currently being serviced (I1 and I0 in CC register). If any of these two conditions is false, the interrupt is latched and thus remains pending.

- TLI (top level hardware interrupt)

Caution: This hardware interrupt occurs when a specific edge is detected on the dedicated TLI pin. It will be serviced according to the flowchart in [Figure 17](#) as a trap. A TRAP instruction must not be used in a TLI service routine.

- External Interrupts
External interrupts allow the processor to exit from HALT low power mode. External interrupt sensitivity is software selectable through the External Interrupt Control register (EICR).
External interrupt triggered on edge will be latched and the interrupt request automatically cleared upon entering the interrupt service routine.
If several input pins of a group connected to the same interrupt line are selected simultaneously, these will be logically ORed.
- Peripheral Interrupts
Usually the peripheral interrupts cause the MCU to exit from Halt mode except those mentioned in [Table 20: Interrupt mapping](#). A peripheral interrupt occurs when a specific

flag is set in the peripheral status registers and if the corresponding enable bit is set in the peripheral control register.

The general sequence for clearing an interrupt is based on an access to the status register followed by a read or write to an associated register.

Note: The clearing sequence resets the internal latch. A pending interrupt (that is, waiting to be serviced) will therefore be lost if the clear sequence is executed.

7.3 Interrupts and low power modes

All interrupts allow the processor to exit the Wait low power mode. On the contrary, only external and other specified interrupts allow the processor to exit from the Halt modes (see column “Exit from Halt/Active Halt” in [Table 20: Interrupt mapping](#)). When several pending interrupts are present while exiting Halt mode, the first one serviced can only be an interrupt with “exit from Halt mode” capability and it is selected through the same decision process shown in [Figure 18](#).

Note: If an interrupt that is not able to exit from Halt mode is pending with the highest priority when exiting Halt mode, this interrupt is serviced after the first one serviced.

7.4 Concurrent and nested management

The following [Figure 19](#) and [Figure 20](#) show two different interrupt management modes. The first is called concurrent mode and does not allow an interrupt to be interrupted, unlike the nested mode in [Figure 20](#). The interrupt hardware priority is given in this order from the lowest to the highest: MAIN, IT4, IT3, IT2, IT1, IT0, TLI. The software priority is given for each interrupt.

Warning: A stack overflow may occur without notifying the software of the failure.

Figure 19. Concurrent interrupt management

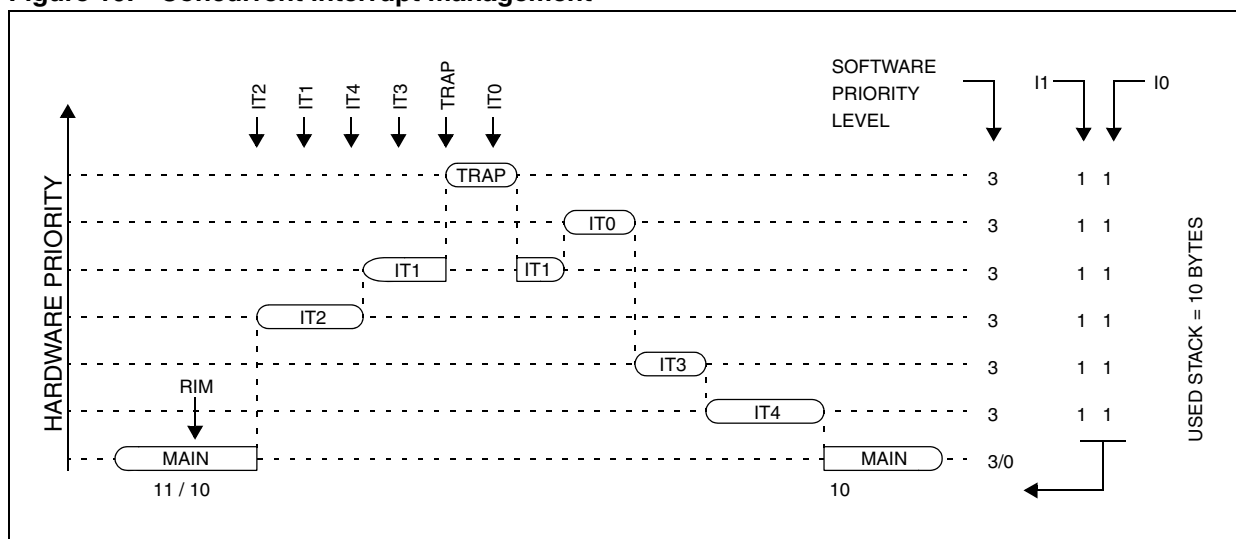
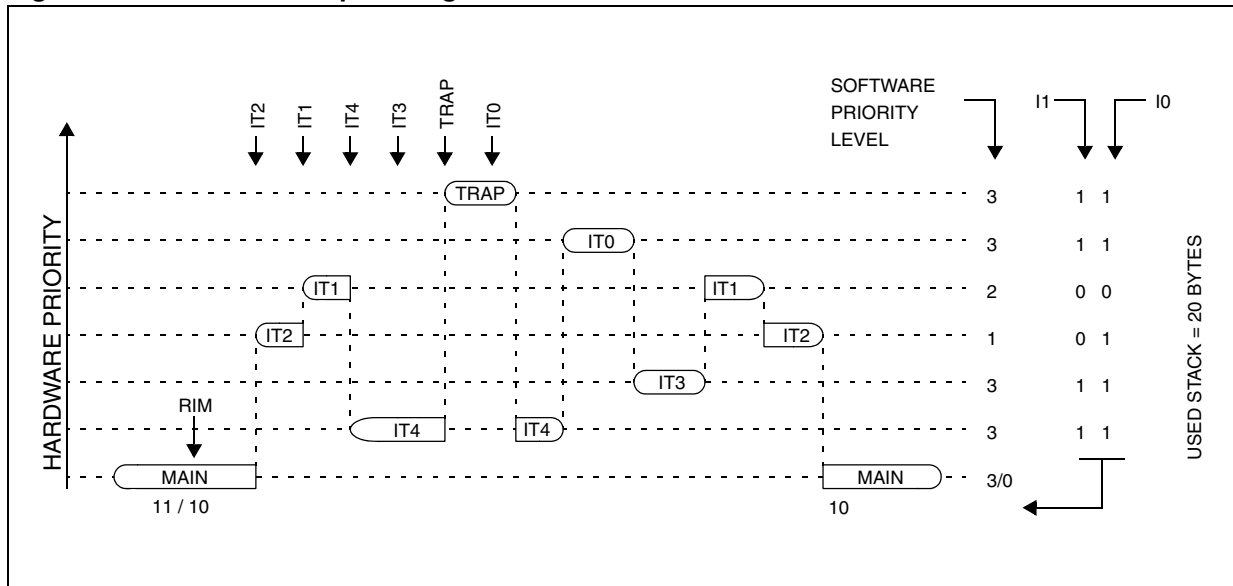

Figure 20. Nested interrupt management



7.5 Interrupt register description

7.5.1 CPU CC register interrupt bits

CPU CC					Reset value: 111x 1010 (xAh)		
7	6	5	4	3	2	1	0
1	1	I1	H	I0	N	Z	C
		RW	RW	RW	RW	RW	RW

Table 16. CPU CC register interrupt bits description

Bit	Name	Function
5	I1	Interrupt Software Priority 1
3	I0	Interrupt Software Priority 0

These two bits indicate the current interrupt software priority (see [Table 17](#)) and are set/cleared by hardware when entering in interrupt. The loaded value is given by the corresponding bits in the interrupt software priority registers (ISPRx).

They can be also set/cleared by software with the RIM, SIM, HALT, WFI, IRET and PUSH/POP instructions (see [Table 19: Interrupt dedicated instruction set](#)).

Table 17. Interrupt software priority levels

Interrupt software priority	Level	I1	I0
Level 0 (main)	Low ↓ High	1	0
Level 1		0	1
Level 2		0	0
Level 3 (= interrupt disable ⁽¹⁾)		1	1

1. TLI, TRAP and RESET events can interrupt a level 3 program.

7.5.2 Interrupt software priority registers (ISPRx)

These four registers are read/write, with the exception of bits 7:4 of ISPR3, which are read only.

ISPRx	Reset value: 1111 1111 (FFh)							
	7	6	5	4	3	2	1	0
ISPR0	I1_3	I0_3	I1_2	I0_2	I1_1	I0_1	I1_0	I0_0
ISPR1	I1_7	I0_7	I1_6	I0_6	I1_5	I0_5	I1_4	I0_4
ISPR2	I1_11	I0_11	I1_10	I0_10	I1_9	I0_9	I1_8	I0_8
ISPR3	1	1	1	1	I1_13	I0_13	I1_12	I0_12

These four registers contain the interrupt software priority of each interrupt vector.

- Each interrupt vector (except RESET and TRAP) has corresponding bits in these registers where its own software priority is stored. This correspondence is shown in the following [Table 18](#).

Table 18. Interrupt priority bits

Vector address	ISPRx bits
FFFBh-FFFAh	I1_0 and I0_0 bits ⁽¹⁾
FFF9h-FFF8h	I1_1 and I0_1 bits
...	...
FFE1h-FFE0h	I1_13 and I0_13 bits

1. Bits in the ISPRx registers which correspond to the TLI can be read and written but they are not significant in the interrupt process management.

- Each I1_x and I0_x bit value in the ISPRx registers has the same meaning as the I1 and I0 bits in the CC register.
- Level 0 cannot be written (I1_x = 1, I0_x = 0). In this case, the previously stored value is kept (Example: previous = CFh, write = 64h, result = 44h).

The TLI, RESET, and TRAP vectors have no software priorities. When one is serviced, the I1 and I0 bits of the CC register are both set.

Caution: If the I1_x and I0_x bits are modified while the interrupt x is executed the following behavior has to be considered: If the interrupt x is still pending (new interrupt or flag not cleared) and the new software priority is higher than the previous one, the interrupt x is re-entered. Otherwise, the software priority stays unchanged up to the next interrupt request (after the IRET of the interrupt x).

Table 19. Interrupt dedicated instruction set

Instruction	New description	Function/Example	I1	H	I0	N	Z	C
HALT	Entering Halt mode		1		0			
IRET	Interrupt routine return	Pop CC, A, X, PC	I1	H	I0	N	Z	C
JRM	Jump if I1:0 = 11 (level 3)	I1:0 = 11 ?						
JRNM	Jump if I1:0 <> 11	I1:0 <> 11 ?						
POP CC	Pop CC from the Stack	Mem => CC	I1	H	I0	N	Z	C
RIM	Enable interrupt (level 0 set)	Load I0 in I1:0 of CC	1		0			
SIM	Disable interrupt (level 3 set)	Load I1 in I1:0 of CC	1		1			
TRAP	Software trap	Software NMI	1		1			
WFI	Wait for interrupt		1		0			

Note: During the execution of an interrupt routine, the HALT, POPCC, RIM, SIM and WFI instructions change the current software priority up to the next IRET instruction or one of the previously mentioned instructions.

Table 20. Interrupt mapping

No.	Source block	Description	Register label	Priority order	Exit from Halt ⁽¹⁾	Address vector
	RESET	Reset	N/A		yes	FFFEh-FFFFh
	TRAP	Software interrupt			no	FFFCh-FFFDh
0	TLI	External top level interrupt	EICR		yes	FFFAh-FFFBh
1	MCC/RTC	Main clock controller time base interrupt	MCCSR	Higher priority ↓ Lower priority	yes	FFF8h-FFF9h
2	ei0	External interrupt port A3..0	N/A		yes	FFF6h-FFF7h
3	ei1	External interrupt port F2..0			yes	FFF4h-FFF5h
4	ei2	External interrupt port B3..0			yes	FFF2h-FFF3h
5	ei3	External interrupt port B7..4			yes	FFF0h-FFF1h
6	Not used					FFEEh-FFEFh
7	SPI	SPI peripheral interrupts	SPICSR	yes ⁽²⁾	FFEC-FFEDh	
8	TIMER A	TIMER A peripheral interrupts	TASR	no	FFEAh-FFEBh	
9	TIMER B	TIMER B peripheral interrupts	TBSR	no	FFE8h-FFE9h	
10	SCI	SCI peripheral interrupts	SCISR	no	FFE6h-FFE7h	
11	AVD	Auxiliary voltage detector interrupt	SICSR	no	FFE4h-FFE5h	
12	I2C	I2C peripheral interrupts	(see peripheral)	no	FFE2h-FFE3h	
13	PWM ART	PWM ART interrupt	ARTCSR	yes ⁽³⁾	FFE0h-FFE1h	

1. In Flash devices only a RESET or MCC/RTC interrupt can be used to wake-up from Active Halt mode.
2. Exit from HALT possible when SPI is in slave mode.
3. Exit from HALT possible when PWM ART is in external clock mode.

7.6 External interrupts

7.6.1 I/O port interrupt sensitivity

The external interrupt sensitivity is controlled by the IPA, IPB and ISxx bits of the EICR register ([Figure 21](#)). This control allows to have up to four fully independent external interrupt source sensitivities.

Each external interrupt source can be generated on four (or five) different events on the pin:

- Falling edge
- Rising edge
- Falling and rising edge
- Falling edge and low level
- Rising edge and high level (only for ei0 and ei2)

To guarantee correct functionality, the sensitivity bits in the EICR register can be modified only when the I1 and I0 bits of the CC register are both set to 1 (level 3). This means that interrupts must be disabled before changing sensitivity.

The pending interrupts are cleared by writing a different value in the ISx[1:0], IPA or IPB bits of the EICR.

Figure 21. External interrupt control bits

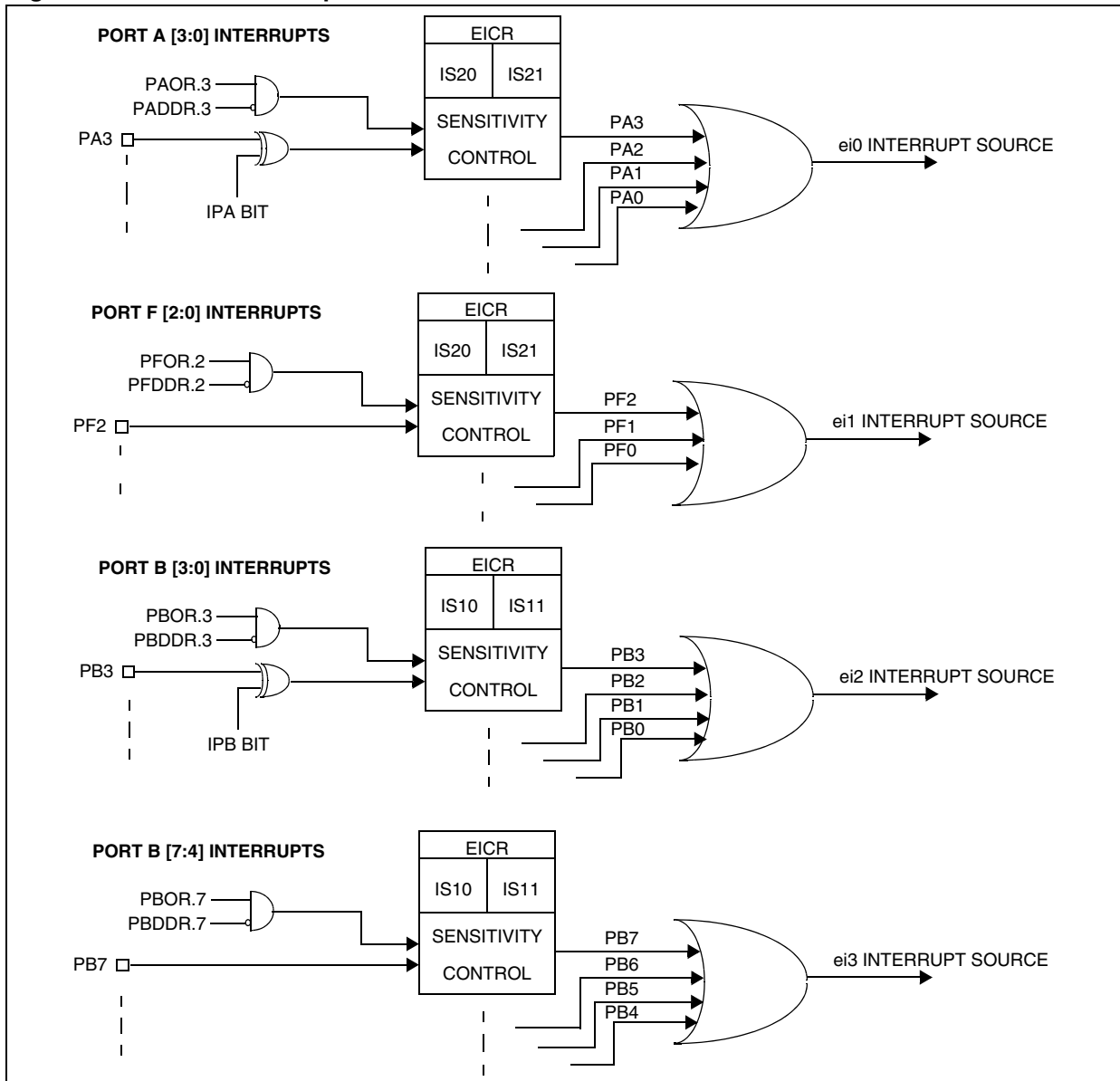

7.6.2 External interrupt control register (EICR)

EICR Reset value: 0000 0000 (00h)

7	6	5	4	3	2	1	0
IS1[1:0]		IPB	IS2[1:0]		IPA	TLIS	TLIE
RW		RW	RW		RW	RW	RW

Table 21. EICR register description

Bit	Name	Function
7:6	IS1[1:0]	<p><i>ei2 and ei3 sensitivity</i></p> <p>The interrupt sensitivity, defined using the IS1[1:0] bits, is applied to the following external interrupts:</p> <ul style="list-style-type: none"> - ei2 (port B3..0) (see Table 22) - ei3 (port B7..4) (see Table 23) <p>These 2 bits can be written only when I1 and I0 of the CC register are both set to 1 (level 3).</p>
5	IPB	<p><i>Interrupt polarity for port B</i></p> <p>This bit is used to invert the sensitivity of the port B [3:0] external interrupts. It can be set and cleared by software only when I1 and I0 of the CC register are both set to 1 (level 3).</p> <p>0: No sensitivity inversion 1: Sensitivity inversion</p>
4:3	IS2[1:0]	<p><i>ei0 and ei1 sensitivity</i></p> <p>The interrupt sensitivity, defined using the IS2[1:0] bits, is applied to the following external interrupts:</p> <ul style="list-style-type: none"> - ei0 (port A3..0) (see Table 24) - ei1 (port F2..0) (see Table 25) <p>These 2 bits can be written only when I1 and I0 of the CC register are both set to 1 (level 3).</p>
2	IPA	<p><i>Interrupt polarity for port A</i></p> <p>This bit is used to invert the sensitivity of the port A [3:0] external interrupts. It can be set and cleared by software only when I1 and I0 of the CC register are both set to 1 (level 3).</p> <p>0: No sensitivity inversion 1: Sensitivity inversion</p>
1	TLIS	<p><i>TLI sensitivity</i></p> <p>This bit allows to toggle the TLI edge sensitivity. It can be set and cleared by software only when TLIE bit is cleared.</p> <p>0: Falling edge 1: Rising edge</p>
0	TLIE	<p><i>TLI enable</i></p> <p>This bit allows to enable or disable the TLI capability on the dedicated pin. It is set and cleared by software.</p> <p>0: TLI disabled 1: TLI enabled</p> <p><i>Note: A parasitic interrupt can be generated when clearing the TLIE bit.</i></p>

Table 22. Interrupt sensitivity - ei2 (port B3..0)

IS11	IS10	External interrupt sensitivity	
		IPB bit = 0	IPB bit = 1
0	0	Falling edge and low level	Rising edge and high level
0	1	Rising edge only	Falling edge only
1	0	Falling edge only	Rising edge only
1	1	Rising and falling edge	

Table 23. Interrupt sensitivity - ei3 (port B7..4)

IS11	IS10	External interrupt sensitivity	
		IPB bit = 0	IPB bit = 1
0	0	Falling edge and low level	
0	1	Rising edge only	
1	0	Falling edge only	
1	1	Rising and falling edge	

Table 24. Interrupt sensitivity - ei0 (port A3..0)

IS21	IS20	External interrupt sensitivity	
		IPA bit = 0	IPA bit = 1
0	0	Falling edge and low level	Rising edge and high level
0	1	Rising edge only	Falling edge only
1	0	Falling edge only	Rising edge only
1	1	Rising and falling edge	

Table 25. Interrupt sensitivity - ei1 (port F2..0)

IS21	IS20	External interrupt sensitivity	
		IPA bit = 0	IPA bit = 1
0	0	Falling edge and low level	
0	1	Rising edge only	
1	0	Falling edge only	
1	1	Rising and falling edge	

Table 26. Nested interrupts register map and reset values

Address (Hex.)	Register label	7	6	5	4	3	2	1	0
0024h	ISPR0 Reset value	ei1		ei0		MCC		TLI	
		I1_3 1	I0_3 1	I1_2 1	I0_2 1	I1_1 1	I0_1 1	1	1
0025h	ISPR1 Reset value	SPI		Reserved		ei3		ei2	
		I1_7 1	I0_7 1	I1_6 1	I0_6 1	I1_5 1	I0_5 1	I1_4 1	I0_4 1
0026h	ISPR2 Reset value	AVD		SCI		TIMER B		TIMER A	
		I1_11 1	I0_11 1	I1_10 1	I0_10 1	I1_9 1	I0_9 1	I1_8 1	I0_8 1
0027h	ISPR3 Reset value	1	1	1	1	PWMART		I2C	
						I1_13 1	I0_13 1	I1_12 1	I0_12 1
0028h	EICR Reset value	IS11 0	IS10 0	IPB 0	IS21 0	IS20 0	IPA 0	TLIS 0	TLIE 0

8 Power saving modes

8.1 Introduction

To give a large measure of flexibility to the application in terms of power consumption, four main power saving modes are implemented in the ST7 (see [Figure 22](#)): Slow, Wait (Slow Wait), Active Halt and Halt.

After a RESET the normal operating mode is selected by default (Run mode). This mode drives the device (CPU and embedded peripherals) by means of a master clock which is based on the main oscillator frequency divided or multiplied by 2 (f_{OSC2}).

From Run mode, the different power saving modes may be selected by setting the relevant register bits or by calling the specific ST7 software instruction whose action depends on the oscillator status.

Figure 22. Power saving mode transitions

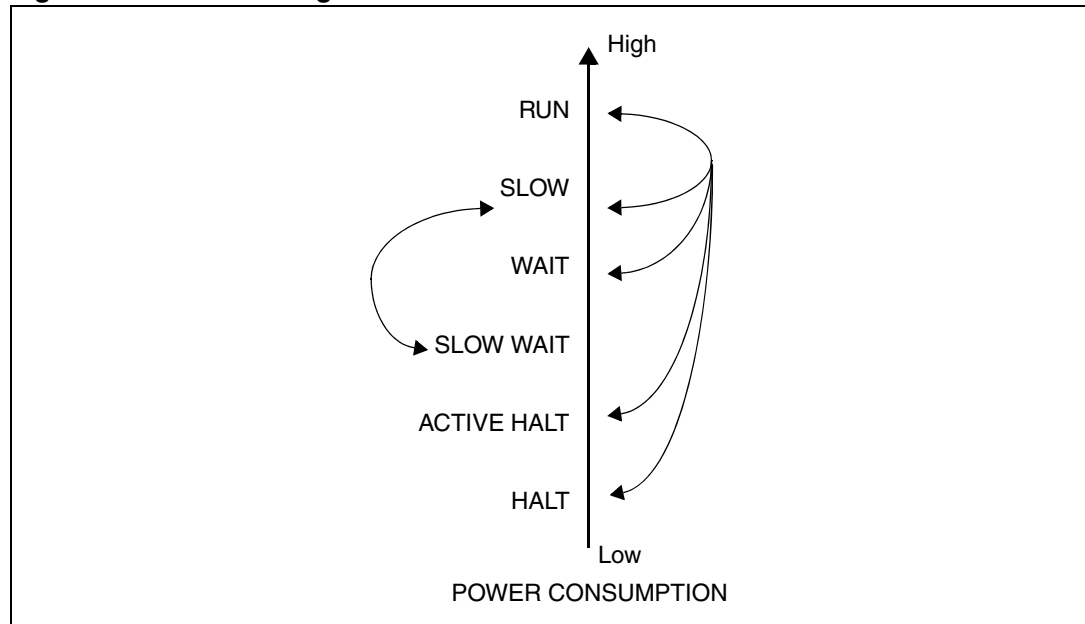

8.2 Slow mode

This mode has two targets:

- To reduce power consumption by decreasing the internal clock in the device,
- To adapt the internal clock frequency (f_{CPU}) to the available supply voltage.

Slow mode is controlled by three bits in the MCCR register: the SMS bit which enables or disables Slow mode and two CPx bits which select the internal slow frequency (f_{CPU}).

In this mode, the master clock frequency (f_{OSC2}) can be divided by 2, 4, 8 or 16. The CPU and peripherals are clocked at this lower frequency (f_{CPU}).

Note: Slow Wait mode is activated when entering the Wait mode while the device is already in Slow mode.

Figure 23. Slow mode clock transitions

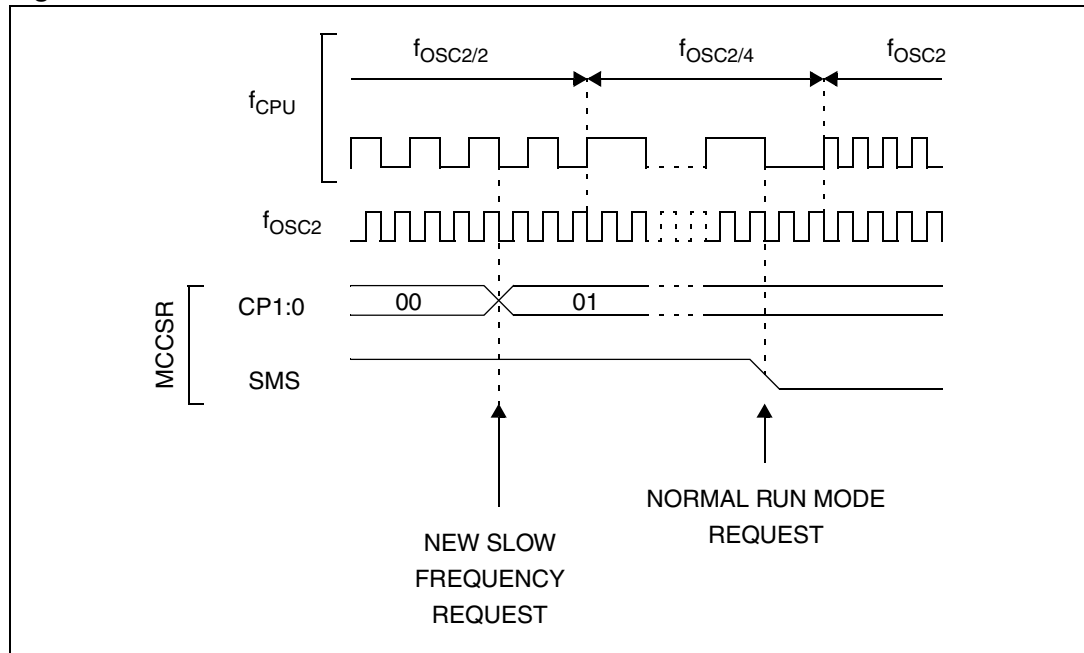

8.3 Wait mode

Wait mode places the MCU in a low power consumption mode by stopping the CPU.

This power saving mode is selected by calling the 'WFI' instruction.

All peripherals remain active. During Wait mode, the I[1:0] bits of the CC register are forced to '10', to enable all interrupts. All other registers and memory remain unchanged. The MCU remains in Wait mode until an interrupt or RESET occurs, whereupon the Program Counter branches to the starting address of the interrupt or Reset service routine.

The MCU will remain in Wait mode until a Reset or an Interrupt occurs, causing it to wake up.

Refer to the following [Figure 24](#).

Figure 24. Wait mode flowchart

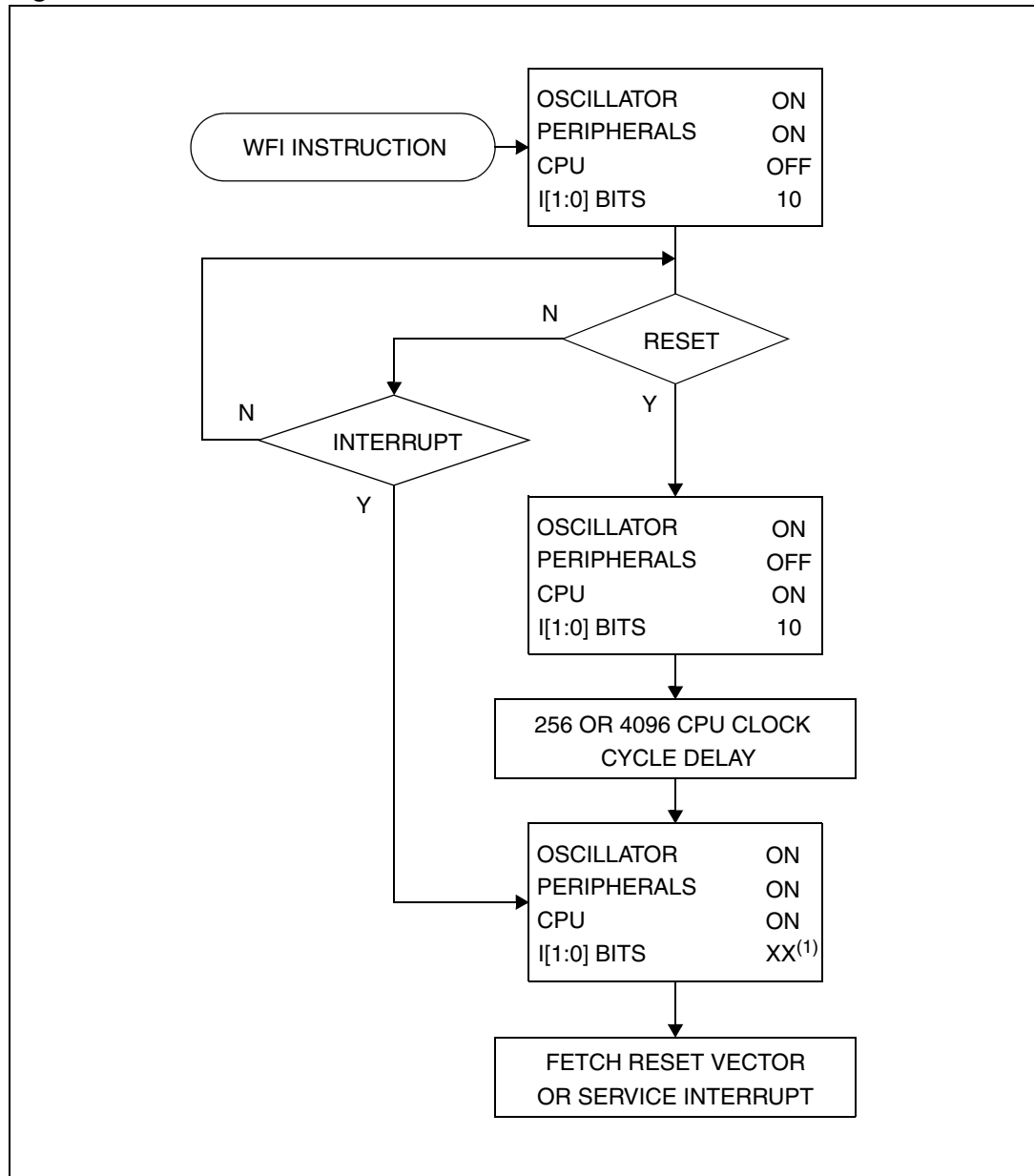

1. Before servicing an interrupt, the CC register is pushed on the stack. The I[1:0] bits of the CC register are set to the current software priority level of the interrupt routine and recovered when the CC register is popped.

8.4 Active Halt and Halt modes

Active Halt and Halt modes are the two lowest power consumption modes of the MCU. They are both entered by executing the 'HALT' instruction. The decision to enter either in Active Halt or Halt mode is given by the MCC/RTC interrupt enable flag (OIE bit in MCCSR register) as shown in [Table 27](#).

Table 27. MCC/RTC low power mode selection

MCCSR OIE bit	Power saving mode entered when HALT instruction is executed
0	Halt
1	Active Halt

8.4.1 Active Halt mode

Active Halt mode is the lowest power consumption mode of the MCU with a real-time clock available. It is entered by executing the 'HALT' instruction when the OIE bit of the Main Clock Controller Status register (MCCSR) is set (see [Section 12.3: ART registers on page 93](#) for more details on the MCCSR register).

The MCU can exit Active Halt mode on reception of an MCC/RTC interrupt or a RESET. When exiting Active Halt mode by means of an interrupt, no 256 or 4096 CPU cycle delay occurs. The CPU resumes operation by servicing the interrupt or by fetching the reset vector which woke it up (see [Figure 26](#)).

When entering Active Halt mode, the I[1:0] bits in the CC register are forced to '10b' to enable interrupts. Therefore, if an interrupt is pending, the MCU wakes up immediately.

In Active Halt mode, only the main oscillator and its associated counter (MCC/RTC) are running to keep a wake-up time base. All other peripherals are not clocked except those which get their clock supply from another clock generator (such as external or auxiliary oscillator).

The safeguard against staying locked in Active Halt mode is provided by the oscillator interrupt.

Note: *As soon as the interrupt capability of one of the oscillators is selected (MCCSR.OIE bit set), entering Active Halt mode while the Watchdog is active does not generate a RESET. This means that the device cannot spend more than a defined delay in this power saving mode.*

Caution: When exiting Active Halt mode following an MCC/RTC interrupt, OIE bit of MCCSR register must not be cleared before t_{DELAY} after the interrupt occurs ($t_{\text{DELAY}} = 256$ or $4096 t_{\text{CPU}}$ delay depending on option byte). Otherwise, the ST7 enters Halt mode for the remaining t_{DELAY} period.

Figure 25. Active Halt timing overview

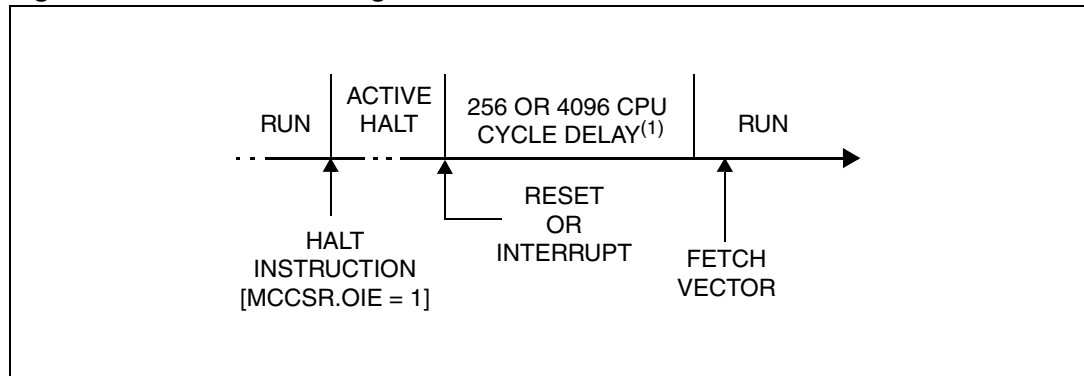

1. This delay occurs only if the MCU exits Active Halt mode by means of a RESET.

Figure 26. Active Halt mode flowchart

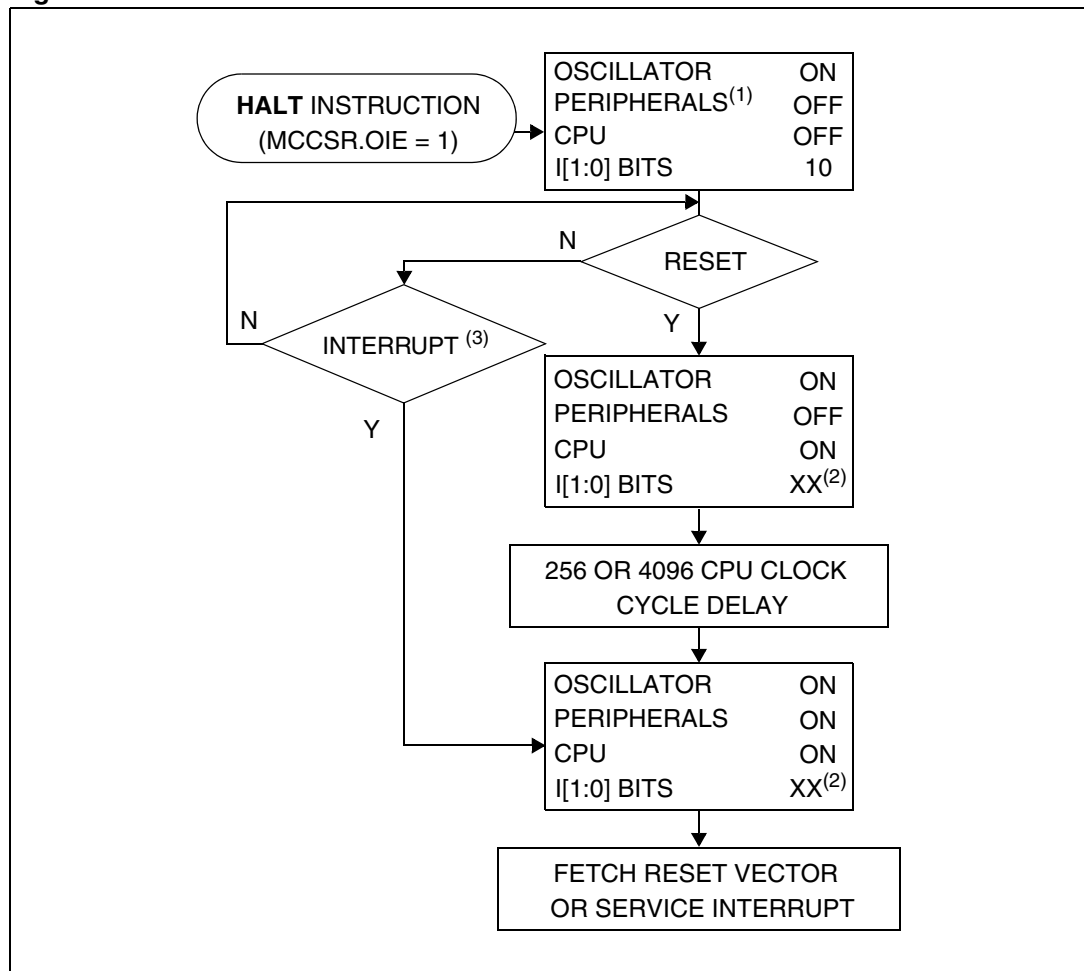

1. Peripheral clocked with an external clock source can still be active.
2. Before servicing an interrupt, the CC register is pushed on the stack. The I[1:0] bits of the CC register are set to the current software priority level of the interrupt routine and restored when the CC register is popped.
3. In Flash devices only the MCC/RTC interrupt can exit the MCU from Active Halt mode.

8.4.2 Halt mode

The Halt mode is the lowest power consumption mode of the MCU. It is entered by executing the 'HALT' instruction when the OIE bit of the Main Clock Controller Status register (MCCSR) is cleared (see [Section 11: Main clock controller with real-time clock and beeper \(MCC/RTC\) on page 82](#) for more details on the MCCSR register).

The MCU can exit Halt mode on reception of either a specific interrupt (see [Section Table 20.: Interrupt mapping on page 56](#)) or a RESET. When exiting Halt mode by means of a RESET or an interrupt, the oscillator is immediately turned on and the 256 or 4096 CPU cycle delay is used to stabilize the oscillator. After the start up delay, the CPU resumes operation by servicing the interrupt or by fetching the reset vector which woke it up (see [Figure 28](#)).

When entering Halt mode, the I[1:0] bits in the CC register are forced to '10b' to enable interrupts. Therefore, if an interrupt is pending, the MCU wakes up immediately.

In Halt mode, the main oscillator is turned off causing all internal processing to be stopped, including the operation of the on-chip peripherals. All peripherals are not clocked except the ones which get their clock supply from another clock generator (such as an external or auxiliary oscillator).

The compatibility of Watchdog operation with Halt mode is configured by the 'WDGHALT' option bit of the option byte. The HALT instruction when executed while the Watchdog system is enabled, can generate a Watchdog RESET (see [Section 21.1.1: Flash configuration on page 223](#) for more details).

Figure 27. Halt timing overview

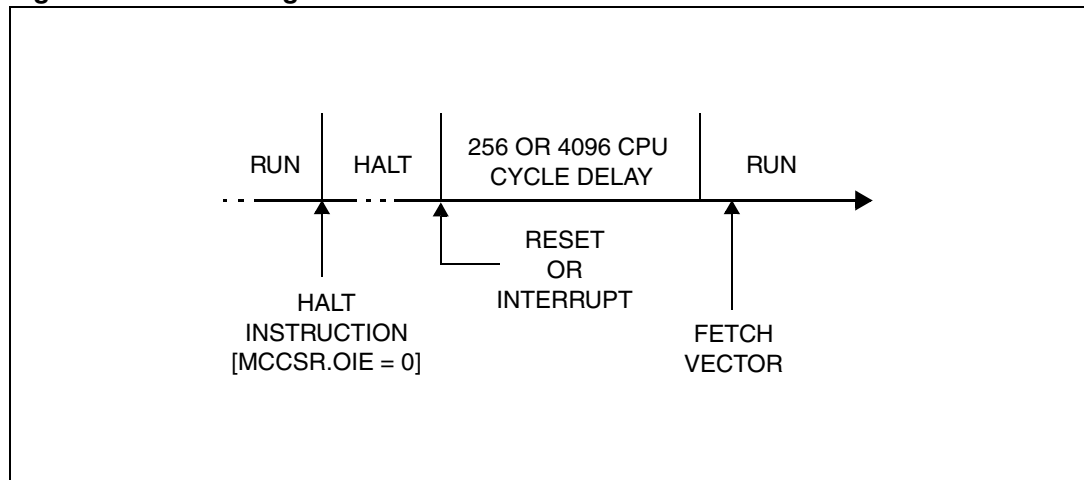
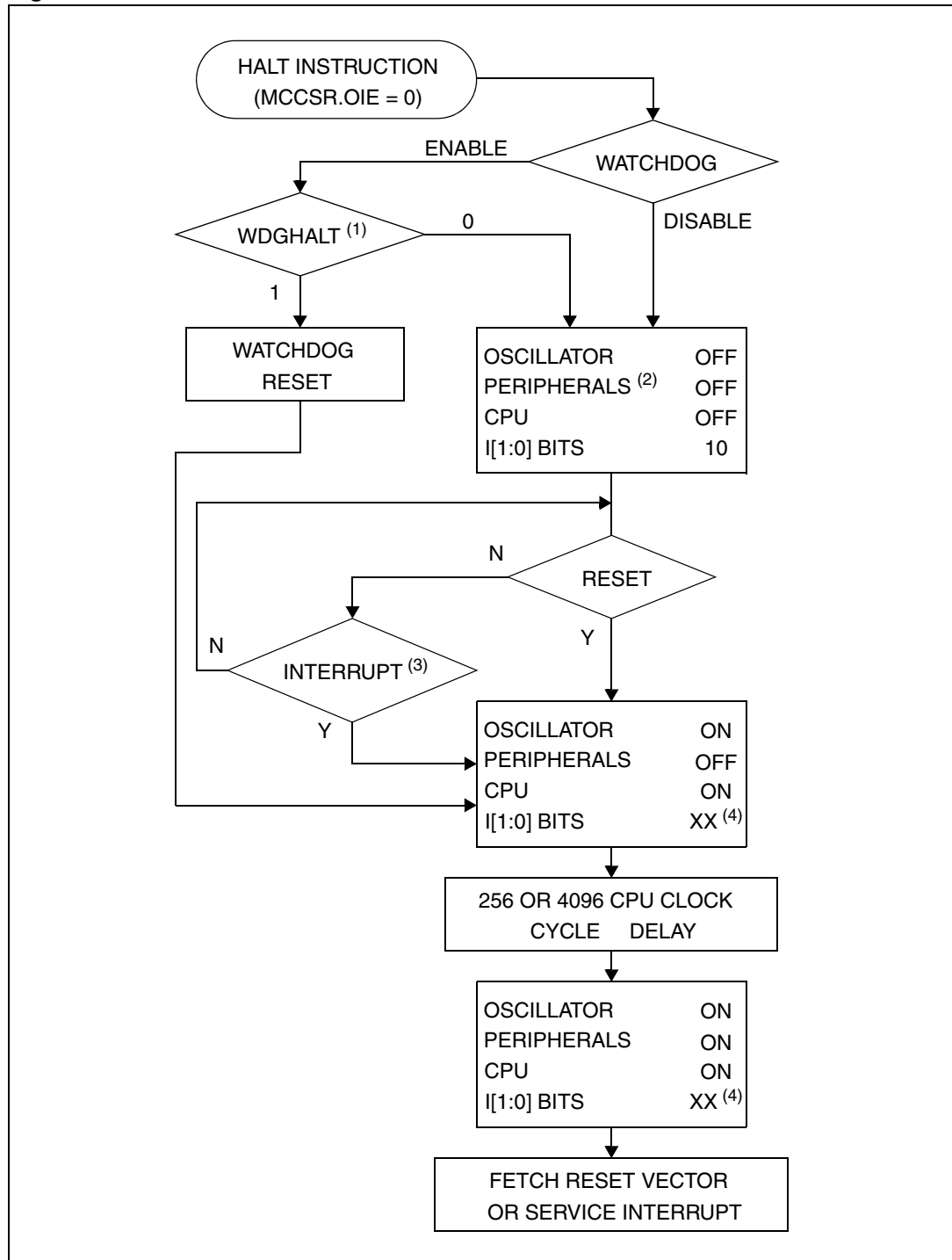

Figure 28. Halt mode flowchart



1. WDGHALT is an option bit. See [Section 21.1.1: Flash configuration on page 223](#) for more details.
2. Peripheral clocked with an external clock source can still be active.
3. Only some specific interrupts can exit the MCU from Halt mode (such as external interrupt). Refer to [Table 20: Interrupt mapping](#) for more details.
4. Before servicing an interrupt, the CC register is pushed on the stack. The I[1:0] bits of the CC register are set to the current software priority level of the interrupt routine and recovered when the CC register is popped.

Halt mode recommendations

- Make sure that an external event is available to wake up the microcontroller from Halt mode.
- When using an external interrupt to wake up the microcontroller, re-initialize the corresponding I/O as “Input Pull-up with Interrupt” before executing the HALT instruction. The main reason for this is that the I/O may be wrongly configured due to external interference or by an unforeseen logical condition.
- For the same reason, reinitialize the level sensitiveness of each external interrupt as a precautionary measure.
- The opcode for the HALT instruction is 0x8E. To avoid an unexpected HALT instruction due to a program counter failure, it is advised to clear all occurrences of the data value 0x8E from memory. For example, avoid defining a constant in ROM with the value 0x8E.
- As the HALT instruction clears the interrupt mask in the CC register to allow interrupts, the user may choose to clear all pending interrupt bits before executing the HALT instruction. This avoids entering other peripheral interrupt routines after executing the external interrupt routine corresponding to the wake-up event (reset or external interrupt).

Related documentation

ST7 Keypad Decoding Techniques, Implementing Wake-Up on Keystroke (AN 980)

How to Minimize the ST7 Power Consumption (AN1014)

Using an active RC to wake up the ST7LITE0 from power saving mode (AN1605)

9 I/O ports

9.1 Introduction

The I/O ports offer different functional modes:

- transfer of data through digital inputs and outputs

and for specific pins:

- external interrupt generation
- alternate signal input/output for the on-chip peripherals.

An I/O port contains up to eight pins. Each pin can be programmed independently as digital input (with or without interrupt generation) or digital output.

9.2 Functional description

Each port has two main registers:

- Data Register (DR)
- Data Direction Register (DDR)

and one optional register:

- Option Register (OR)

Each I/O pin may be programmed using the corresponding register bits in the DDR and OR registers (bit X corresponding to pin X of the port). The same correspondence is used for the DR register.

The following description takes into account the OR register (for specific ports which do not provide this register refer to [Section 9.3: I/O port implementation on page 74](#)). The generic I/O block diagram is shown in [Figure 29](#).

9.2.1 Input modes

The input configuration is selected by clearing the corresponding DDR register bit.

In this case, reading the DR register returns the digital value applied to the external I/O pin.

Different input modes can be selected by software through the OR register.

- Note:*
- 1 *Writing the DR register modifies the latch value but does not affect the pin status.*
 - 2 *When switching from input to output mode, the DR register has to be written first to drive the correct level on the pin as soon as the port is configured as an output.*
 - 3 *Do not use read/modify/write instructions (BSET or BRES) to modify the DR register as this might corrupt the DR content for I/Os configured as input.*

External interrupt function

When an I/O is configured as Input with Interrupt, an event on this I/O can generate an external interrupt request to the CPU.

Each pin can independently generate an interrupt request. The interrupt sensitivity is independently programmable using the sensitivity bits in the EICR register.

Each external interrupt vector is linked to a dedicated group of I/O port pins (see pinout description and interrupt section). If several input pins are selected simultaneously as interrupt sources, these are first detected according to the sensitivity bits in the EICR register and then logically ORed.

The external interrupts are hardware interrupts, which means that the request latch (not accessible directly by the application) is automatically cleared when the corresponding interrupt vector is fetched. To clear an unwanted pending interrupt by software, the sensitivity bits in the EICR register must be modified.

9.2.2 Output modes

The output configuration is selected by setting the corresponding DDR register bit. In this case, writing the DR register applies this digital value to the I/O pin through the latch. Then reading the DR register returns the previously stored value.

Two different output modes can be selected by software through the OR register: Output push-pull and open-drain. The DR register value and output pin status are shown in the following [Table 28](#).

Table 28. I/O output mode selection

DR	Push-pull	Open-drain
0	V_{SS}	V_{SS}
1	V_{DD}	Floating

9.2.3 Alternate functions

When an on-chip peripheral is configured to use a pin, the alternate function is automatically selected. This alternate function takes priority over the standard I/O programming.

When the signal is coming from an on-chip peripheral, the I/O pin is automatically configured in output mode (push-pull or open-drain according to the peripheral).

When the signal is going to an on-chip peripheral, the I/O pin must be configured in input mode. In this case, the pin state is also digitally readable by addressing the DR register.

Note: Input pull-up configuration can cause unexpected value at the input of the alternate peripheral input. When an on-chip peripheral use a pin as input and output, this pin has to be configured in input floating mode.

Figure 29. I/O port general block diagram

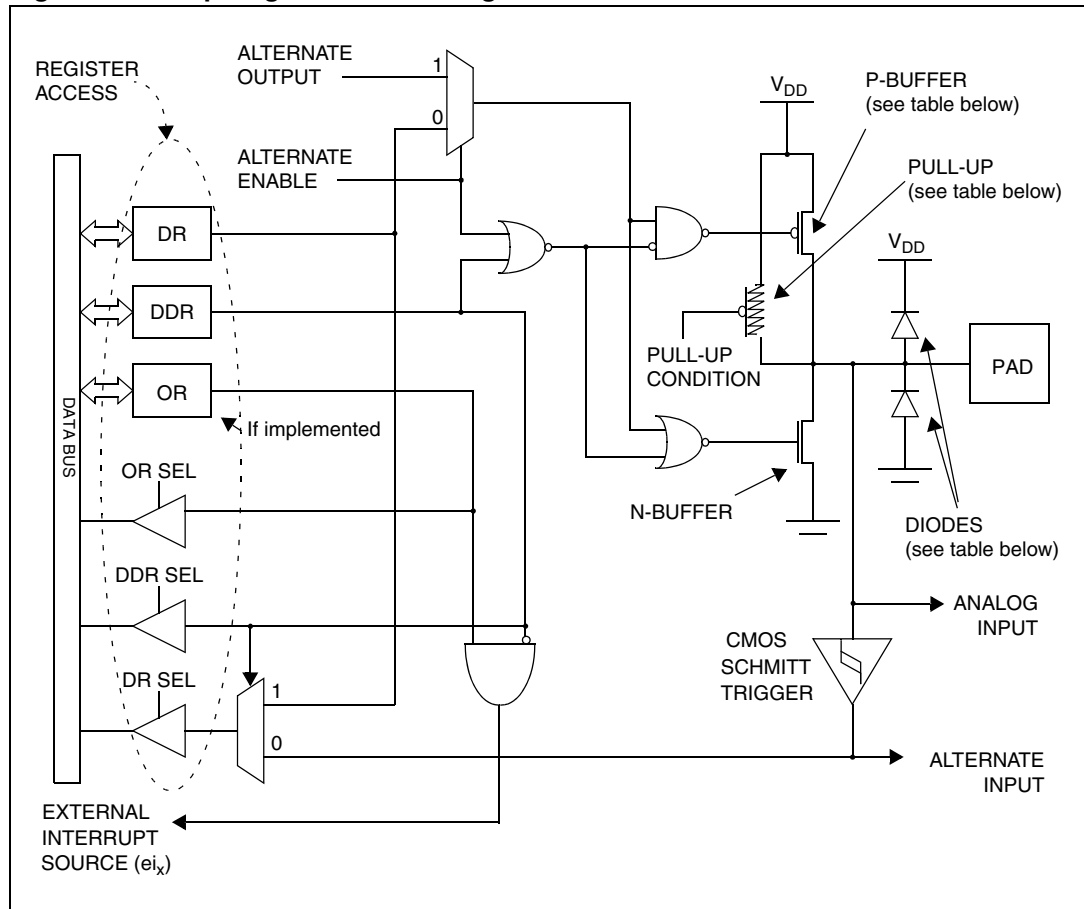

Table 29. I/O port mode options

Configuration mode		Pull-up	P-buffer	Diodes	
				to V _{DD}	to V _{SS}
Input	Floating with/without Interrupt	Off	Off	On	On
	Pull-up with/without Interrupt	On			
Output	Push-pull	Off	On		
	Open-drain (logic level)		Off		
	True open-drain	NI	NI	NI ⁽¹⁾	

1. The diode to V_{DD} is not implemented in the true open-drain pads. A local protection between the pad and V_{SS} is implemented to protect the device against positive stress.

Legend:

- Off - Implemented not activated
- On - Implemented and activated
- NI - Not implemented

Table 30. I/O port configurations

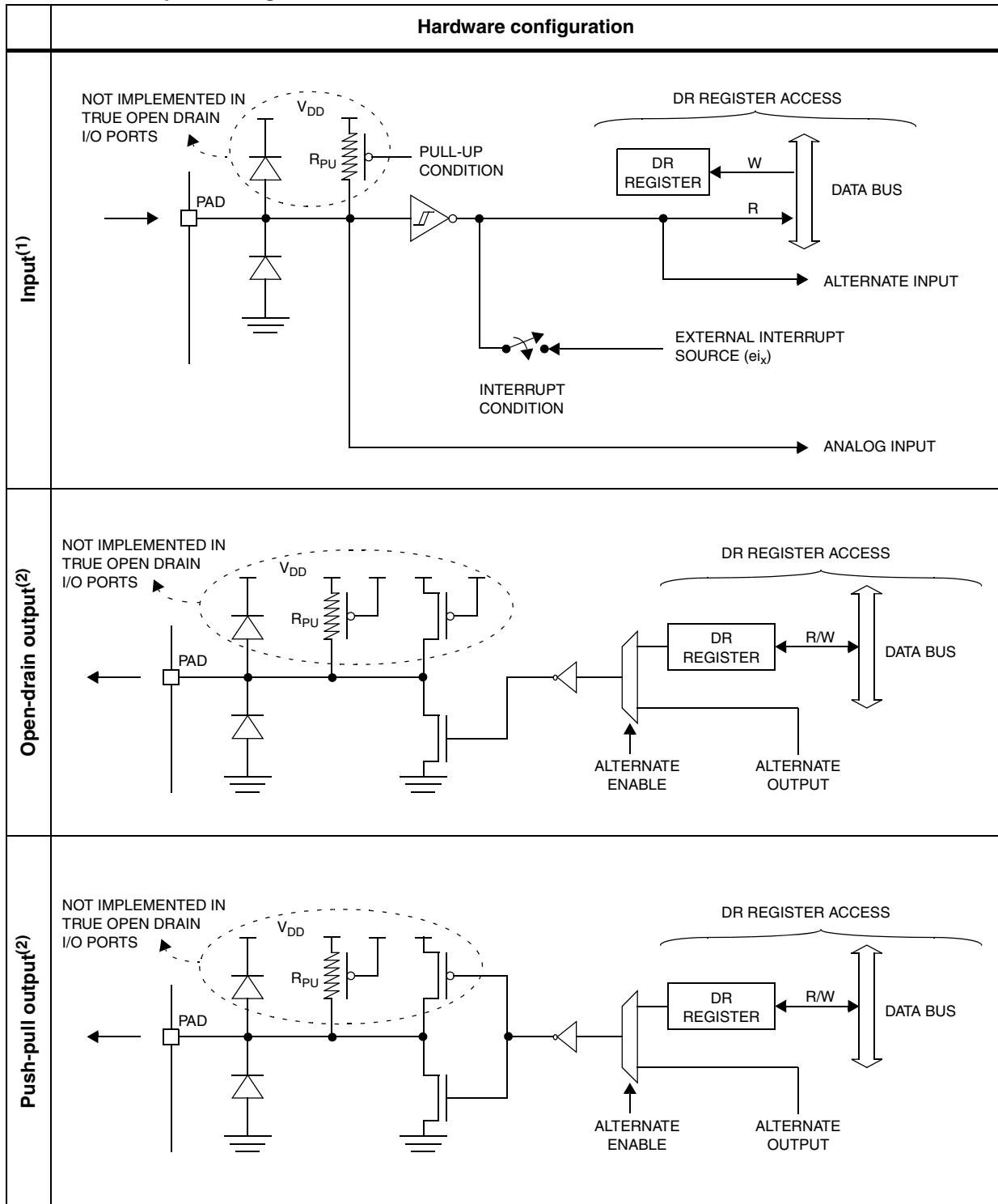

1. When the I/O port is in input configuration and the associated alternate function is enabled as an output, reading the DR register will read the alternate function output status.
2. When the I/O port is in output configuration and the associated alternate function is enabled as an input, the alternate function reads the pin status given by the DR register content.

Caution: The alternate function must not be activated as long as the pin is configured as input with interrupt, in order to avoid generating spurious interrupts.

Analog alternate function

When the pin is used as an ADC input, the I/O must be configured as floating input. The analog multiplexer (controlled by the ADC registers) switches the analog voltage present on the selected pin to the common analog rail which is connected to the ADC input.

It is recommended not to change the voltage level or loading on any port pin while conversion is in progress. Furthermore it is recommended not to have clocking pins located close to a selected analog pin.

Warning: The analog input voltage level must be within the limits stated in the absolute maximum ratings.

9.3 I/O port implementation

The hardware implementation on each I/O port depends on the settings in the DDR and OR registers and specific feature of the I/O port such as ADC Input or true open-drain.

Switching these I/O ports from one state to another should be done in a sequence that prevents unwanted side effects. Recommended safe transitions are illustrated in [Figure 30](#). Other transitions are potentially risky and should be avoided, since they are likely to present unwanted side-effects such as spurious interrupt generation.

Figure 30. Interrupt I/O port state transitions

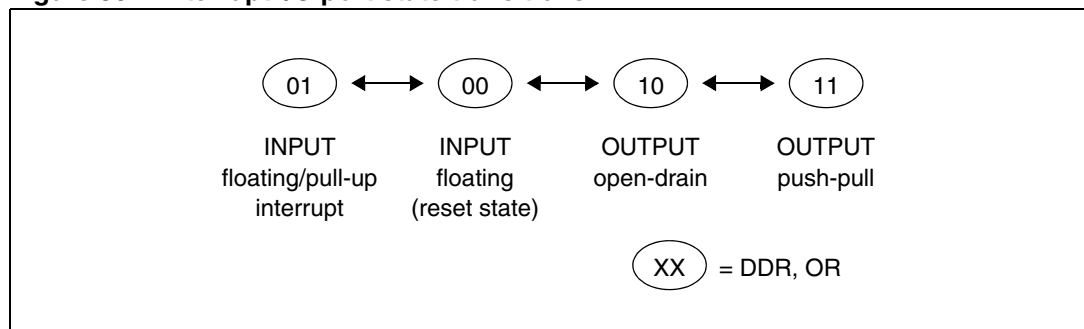

The I/O port register configurations are summarized in the following table.

Table 31. I/O port configuration

Port	Pin name	Input (DDR = 0)		Output (DDR = 1)	
		OR = 0	OR = 1	OR = 0	OR = 1
Port A	PA7:6	floating		true open-drain	
	PA5:4	floating	pull-up	open-drain	push-pull
	PA3	floating	floating interrupt	open-drain	push-pull
	PA2:0	floating	pull-up interrupt	open-drain	push-pull

Table 31. I/O port configuration (continued)

Port	Pin name	Input (DDR = 0)		Output (DDR = 1)	
		OR = 0	OR = 1	OR = 0	OR = 1
Port B	PB7, PB3	floating	floating interrupt	open-drain	push-pull
	PB6:5, PB4, PB2:0	floating	pull-up interrupt	open-drain	push-pull
Port C	PC7:0	floating	pull-up	open-drain	push-pull
Port D	PD7:0	floating	pull-up	open-drain	push-pull
Port E	PE7:3, PE1:0	floating	pull-up	open drain	push-pull
	PE2 (Flash devices)	pull-up input only			
	PE2 (ROM devices)	floating		open drain	push-pull
Port F	PF7:3	floating	pull-up	open-drain	push-pull
	PF2	floating	floating interrupt	open-drain	push-pull
	PF1:0	floating	pull-up interrupt	open-drain	push-pull

9.4 Low power modes

Table 32. Effect of low power modes on I/O ports

Mode	Effect
Wait	No effect on I/O ports. External interrupts cause the device to exit from Wait mode.
Halt	No effect on I/O ports. External interrupts cause the device to exit from Halt mode.

9.5 Interrupts

The external interrupt event generates an interrupt if the corresponding configuration is selected with DDR and OR registers and the interrupt mask in the CC register is not active (RIM instruction).

Table 33. I/O port interrupt control/wake-up capability

Interrupt event	Event flag	Enable control bit	Exit from Wait	Exit from Halt
External interrupt on selected external event	-	DDRx, ORx	Yes	Yes

Table 34. I/O port register map and reset values

Address (Hex.)	Register label	7	6	5	4	3	2	1	0
Reset value of all I/O port registers		0	0	0	0	0	0	0	0
0000h	PADR	MSB							LSB
0001h	PADDR								
0002h	PAOR								

Table 34. I/O port register map and reset values (continued)

Address (Hex.)	Register label	7	6	5	4	3	2	1	0
Reset value of all I/O port registers		0	0	0	0	0	0	0	0
0003h	PBDR	MSB							LSB
0004h	PBDDR								
0005h	PBOR								
0006h	PCDR	MSB							LSB
0007h	PCDDR								
0008h	PCOR								
0009h	PDDR	MSB							LSB
000Ah	PDDDR								
000Bh	PDOR								
000Ch	PEDR	MSB							LSB
000Dh	PEDDR								
000Eh	PEOR								
000Fh	PFDR	MSB							LSB
0010h	PFDDR								
0011h	PFOR								

Related documentation

SPI Communication between ST7 and EEPROM (AN 970)

S/W implementation of I2C bus master (AN1045)

Software LCD driver (AN1048)

10 Watchdog timer (WDG)

10.1 Introduction

The Watchdog timer is used to detect the occurrence of a software fault, usually generated by external interference or by unforeseen logical conditions, which causes the application program to abandon its normal sequence. The Watchdog circuit generates an MCU reset on expiry of a programmed time period, unless the program refreshes the counter's contents before the T6 bit becomes cleared.

10.2 Main features

- Programmable free-running downcounter
- Programmable reset
- Reset (if watchdog activated) when the T6 bit reaches zero
- Optional reset on HALT instruction (configurable by option byte)
- Hardware Watchdog selectable by option byte

10.3 Functional description

The counter value stored in the Watchdog Control register (WDGCR bits T[6:0]), is decremented every $16384 f_{OSC2}$ cycles (approx.), and the length of the timeout period can be programmed by the user in 64 increments.

If the watchdog is activated (the WDGA bit is set) and when the 7-bit timer (bits T[6:0]) rolls over from 40h to 3Fh (T6 becomes cleared), it initiates a reset cycle pulling the \overline{RESET} pin low for typically 30 μ s.

The application program must write in the WDGCR register at regular intervals during normal operation to prevent an MCU reset. This downcounter is free-running: It counts down even if the watchdog is disabled. The value to be stored in the WDGCR register must be between FFh and C0h:

- The WDGA bit is set (watchdog enabled)
- The T6 bit is set to prevent generating an immediate reset
- The T[5:0] bits contain the number of increments which represents the time delay before the watchdog produces a reset (see [Figure 32: Approximate timeout duration](#)). The timing varies between a minimum and a maximum value due to the unknown status of the prescaler when writing to the WDGCR register (see [Figure 33](#)).

Following a reset, the watchdog is disabled. Once activated it cannot be disabled, except by a reset.

The T6 bit can be used to generate a software reset (the WDGA bit is set and the T6 bit is cleared).

If the watchdog is activated, the HALT instruction will generate a Reset.

Figure 31. Watchdog block diagram

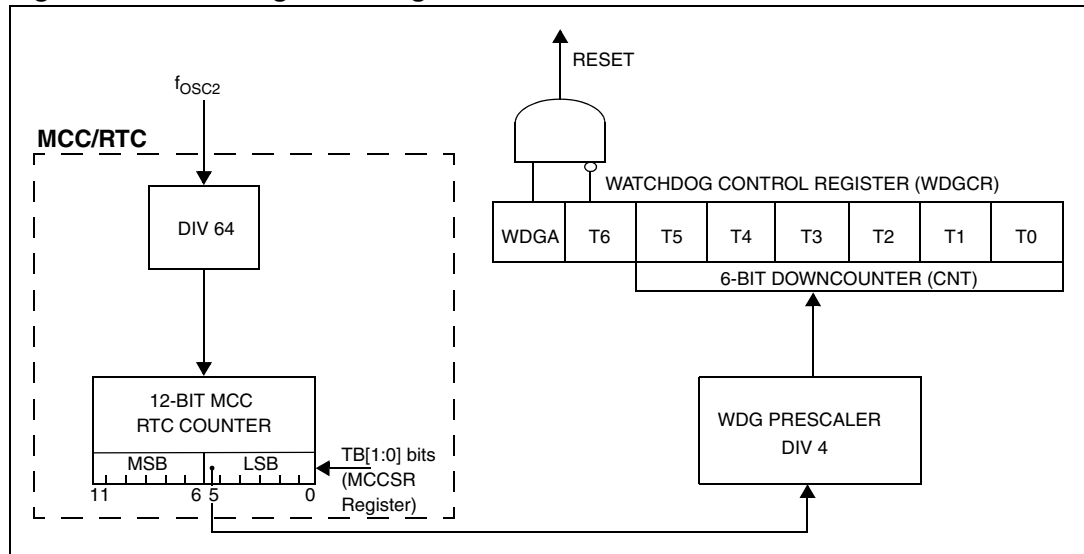

10.4 How to program the watchdog timeout

Figure 32 shows the linear relationship between the 6-bit value to be loaded in the Watchdog Counter (CNT) and the resulting timeout duration in milliseconds. This can be used for a quick calculation without taking the timing variations into account. If more precision is needed, use the formulae in Figure 33.

Caution: When writing to the WDGCR register, always write 1 in the T6 bit to avoid generating an immediate reset.

Figure 32. Approximate timeout duration

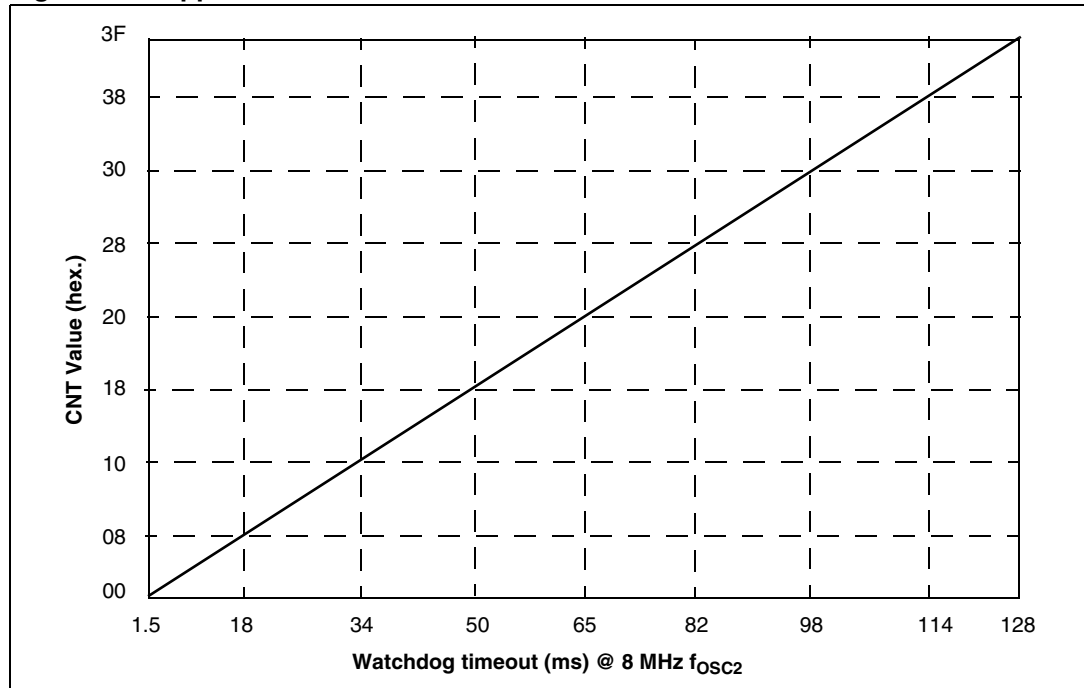

Figure 33. Exact timeout duration (t_{min} and t_{max})

WHERE:

$$t_{min0} = (LSB + 128) \times 64 \times t_{OSC2}$$

$$t_{max0} = 16384 \times t_{OSC2}$$

$$t_{OSC2} = 125ns \text{ if } f_{OSC2} = 8 \text{ MHz}$$

CNT = Value of T[5:0] bits in the WDGCR register (6 bits)

MSB and LSB are values from the table below depending on the timebase selected by the TB[1:0] bits in the MCCSR register

TB1 bit (MCCSR reg.)	TB0 bit (MCCSR reg.)	Selected MCCSR timebase	MSB	LSB
0	0	2ms	4	59
0	1	4ms	8	53
1	0	10ms	20	35
1	1	25ms	49	54

To calculate the minimum Watchdog Timeout (t_{min}):

IF $CNT < \left\lceil \frac{MSB}{4} \right\rceil$ **THEN** $t_{min} = t_{min0} + 16384 \times CNT \times t_{osc2}$
ELSE $t_{min} = t_{min0} + \left[16384 \times \left(CNT - \left\lceil \frac{4CNT}{MSB} \right\rceil \right) + (192 + LSB) \times 64 \times \left\lceil \frac{4CNT}{MSB} \right\rceil \right] \times t_{osc2}$

To calculate the maximum Watchdog Timeout (t_{max}):

IF $CNT \leq \left\lceil \frac{MSB}{4} \right\rceil$ **THEN** $t_{max} = t_{max0} + 16384 \times CNT \times t_{osc2}$
ELSE $t_{max} = t_{max0} + \left[16384 \times \left(CNT - \left\lceil \frac{4CNT}{MSB} \right\rceil \right) + (192 + LSB) \times 64 \times \left\lceil \frac{4CNT}{MSB} \right\rceil \right] \times t_{osc2}$

Note: In the above formulae, division results must be rounded down to the next integer value.

Example:

With 2ms timeout selected in MCCSR register

Value of T[5:0] bits in WDGCR register (Hex.)	Min. Watchdog Timeout (ms)	Max. Watchdog Timeout (ms)
	t_{min}	t_{max}
00	1.496	2.048
3F	128	128.552

10.5 Low power modes

Table 35. Effect of low power modes on WDG

Mode	Effect		
Slow	No effect on Watchdog		
Wait	No effect on Watchdog		
Halt	OIE bit in MCCR register	WDGHALT bit in Option Byte	
	0	0	No Watchdog reset is generated. The MCU enters Halt mode. The Watchdog counter is decremented once and then stops counting and is no longer able to generate a watchdog reset until the MCU receives an external interrupt or a reset. If an external interrupt is received, the Watchdog restarts counting after 256 or 4096 CPU clocks. If a reset is generated, the Watchdog is disabled (reset state) unless Hardware Watchdog is selected by option byte. For application recommendations see Section 10.7 below.
	0	1	A reset is generated.
	1	x	No reset is generated. The MCU enters Active Halt mode. The Watchdog counter is not decremented. It stop counting. When the MCU receives an oscillator interrupt or external interrupt, the Watchdog restarts counting immediately. When the MCU receives a reset the Watchdog restarts counting after 256 or 4096 CPU clocks.

10.6 Hardware watchdog option

If Hardware Watchdog is selected by option byte, the watchdog is always active and the WDGA bit in the WDGCR is not used. Refer to the option byte description in [Section 21.1.1: Flash configuration on page 223](#).

10.7 Using Halt mode with the WDG (WDGHALT option)

The following recommendation applies if Halt mode is used when the watchdog is enabled: Before executing the HALT instruction, refresh the WDG counter to avoid an unexpected WDG reset immediately after waking up the microcontroller.

10.8 Interrupts

None.

10.9 Register description

10.9.1 Control register (WDGCR)

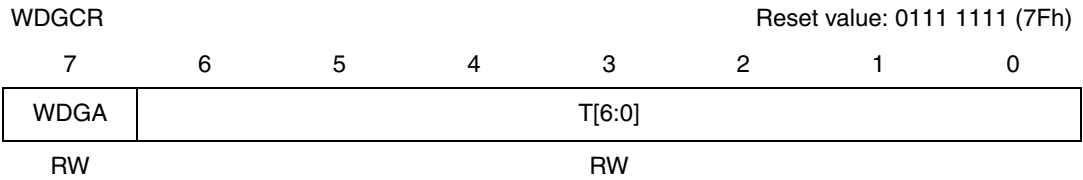

Table 36. WDGCR register description

Bit	Name	Function
7	WDGA	<p><i>Activation bit</i></p> <p>This bit is set by software and only cleared by hardware after a reset. When WDGA = 1, the watchdog can generate a reset.</p> <p>0: Watchdog disabled 1: Watchdog enabled</p> <p><i>Note: This bit is not used if the hardware watchdog option is enabled by option byte.</i></p>
6:0	T[6:0]	<p><i>7-bit counter (MSB to LSB)</i></p> <p>These bits contain the value of the watchdog counter. It is decremented every 16384 f_{OSC2} cycles (approx.). A reset is produced when it rolls over from 40h to 3Fh (T6 becomes cleared).</p>

Table 37. Watchdog timer register map and reset values

Address (Hex.)	Register label	7	6	5	4	3	2	1	0
002Ah	WDGCR Reset Value	WDGA 0	T6 1	T5 1	T4 1	T3 1	T2 1	T1 1	T0 1

11 Main clock controller with real-time clock and beeper (MCC/RTC)

11.1 Introduction

The Main Clock Controller consists of three different functions:

- a programmable CPU clock prescaler
- a clock-out signal to supply external devices
- a real-time clock timer with interrupt capability

Each function can be used independently and simultaneously.

11.2 Programmable CPU clock prescaler

The programmable CPU clock prescaler supplies the clock for the ST7 CPU and its internal peripherals. It manages Slow power saving mode (see [Section 8.2: Slow mode on page 62](#) for more details).

The prescaler selects the f_{CPU} main clock frequency and is controlled by three bits in the MCCSR register: CP[1:0] and SMS.

11.3 Clock-out capability

The clock-out capability is an alternate function of an I/O port pin that outputs a f_{CPU} clock to drive external devices. It is controlled by the MCO bit in the MCCSR register.

Caution: When selected, the clock out pin suspends the clock during Active Halt mode.

11.4 Real-time clock timer (RTC)

The counter of the real-time clock timer allows an interrupt to be generated based on an accurate real-time clock. Four different time bases depending directly on f_{OSC2} are available. The whole functionality is controlled by four bits of the MCCSR register: TB[1:0], OIE and OIF.

When the RTC interrupt is enabled (OIE bit set), the ST7 enters Active Halt mode when the HALT instruction is executed. See [Section 8.4: Active Halt and Halt modes on page 65](#) for more details.

11.5 Beeper

The beep function is controlled by the MCCBCR register. It can output three selectable frequencies on the BEEP pin (I/O port alternate function).

Figure 34. Main clock controller (MCC/RTC) block diagram

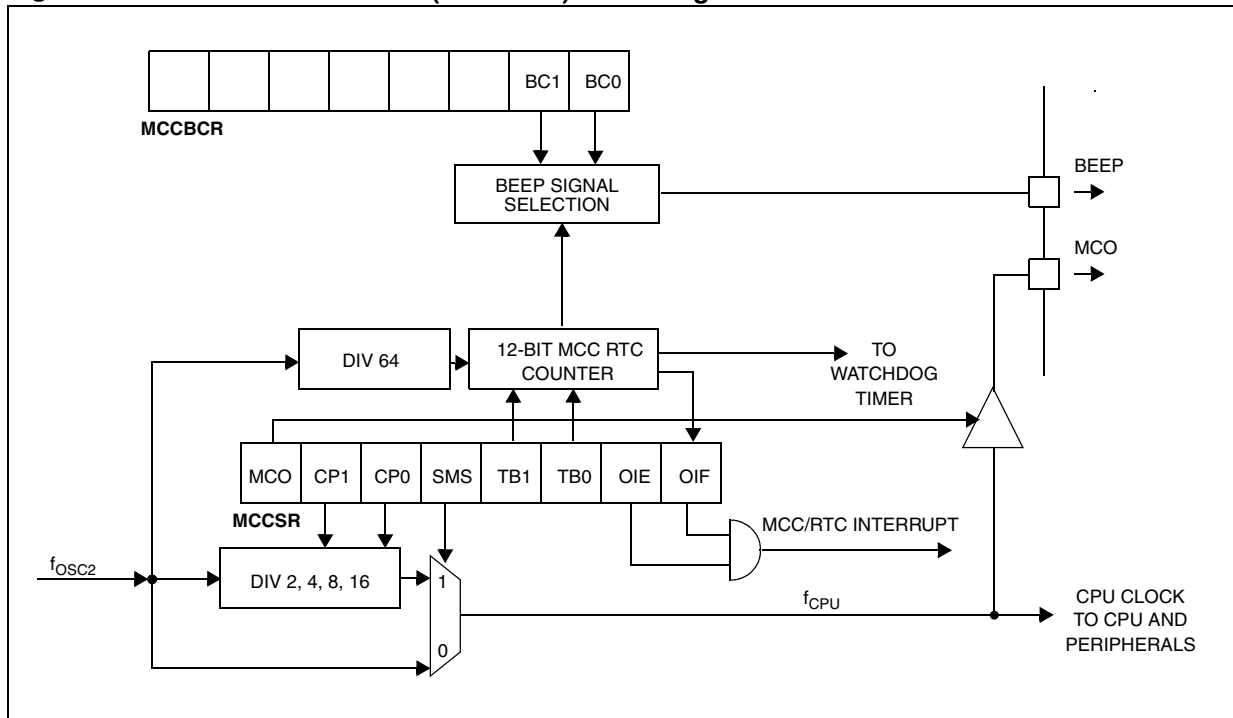

11.6 Low power modes

Table 38. Effect of low power modes on MCC/RTC

Mode	Effect
Wait	No effect on MCC/RTC peripheral. MCC/RTC interrupt causes the device to exit from Wait mode.
Active Halt	No effect on MCC/RTC counter (OIE bit is set), the registers are frozen. MCC/RTC interrupt causes the device to exit from Active Halt mode.
Halt	MCC/RTC counter and registers are frozen. MCC/RTC operation resumes when the MCU is woken up by an interrupt with "exit from HALT" capability.

11.7 Interrupts

The MCC/RTC interrupt event generates an interrupt if the OIE bit of the MCCR register is set and the interrupt mask in the CC register is not active (RIM instruction).

Table 39. MCC/RTC interrupt control/wake-up capability

Interrupt event	Event flag	Enable control bit	Exit from Wait	Exit from Halt
Time base overflow event	OIF	OIE	Yes	No ⁽¹⁾

1. The MCC/RTC interrupt wakes up the MCU from Active Halt mode, not from Halt mode.

11.8 Main clock controller registers

11.8.1 MCC control/status register (MCCSR)

MCCSR	Reset value: 0000 0000 (00h)						
7	6	5	4	3	2	1	0
MCO	CP[1:0]		SMS	TB[1:0]		OIE	OIF
RW	RW		RW	RW		RW	RW

Table 40. MCCSR register description

Bit	Name	Function
7	MCO	<p><i>Main clock out selection</i></p> <p>This bit enables the MCO alternate function on the PF0 I/O port. It is set and cleared by software.</p> <p>0: MCO alternate function disabled (I/O pin free for general-purpose I/O)</p> <p>1: MCO alternate function enabled (f_{CPU} on I/O port)</p> <p><i>Note: To reduce power consumption, the MCO function is not active in Active Halt mode.</i></p>
6:5	CP[1:0]	<p><i>CPU clock prescaler</i></p> <p>These bits select the CPU clock prescaler which is applied in the different slow modes. Their action is conditioned by the setting of the SMS bit. These two bits are set and cleared by software.</p> <p>00: f_{CPU} in Slow mode = $f_{OSC2}/2$</p> <p>01: f_{CPU} in Slow mode = $f_{OSC2}/4$</p> <p>10: f_{CPU} in Slow mode = $f_{OSC2}/8$</p> <p>11: f_{CPU} in Slow mode = $f_{OSC2}/16$</p>
4	SMS	<p><i>Slow mode select</i></p> <p>This bit is set and cleared by software.</p> <p>0: Normal mode. $f_{CPU} = f_{OSC2}$</p> <p>1: Slow mode. f_{CPU} is given by CP1, CP0</p> <p>See Section 8.2: Slow mode on page 62 and Chapter 11: Main clock controller with real-time clock and beeper (MCC/RTC) for more details.</p>
3:2	TB[1:0]	<p><i>Time base control</i></p> <p>These bits select the programmable divider time base. They are set and cleared by software (see Table 41).</p> <p>A modification of the time base is taken into account at the end of the current period (previously set) to avoid an unwanted time shift. This allows to use this time base as a real-time clock.</p>
1	OIE	<p><i>Oscillator interrupt enable</i></p> <p>This bit set and cleared by software.</p> <p>0: Oscillator interrupt disabled</p> <p>1: Oscillator interrupt enabled</p> <p>This interrupt can be used to exit from Active Halt mode.</p> <p>When this bit is set, calling the ST7 software HALT instruction enters the Active Halt power saving mode.</p>

Table 40. MCCSR register description (continued)

Bit	Name	Function
0	OIF	<p><i>Oscillator interrupt flag</i></p> <p>This bit is set by hardware and cleared by software reading the MCCSR register. It indicates when set that the main oscillator has reached the selected elapsed time (TB1:0).</p> <p>0: Timeout not reached 1: Timeout reached</p> <p>Caution: The BRES and BSET instructions must not be used on the MCCSR register to avoid unintentionally clearing the OIF bit.</p>

Table 41. Time base selection

Counter prescaler	Time base		TB1	TB0
	f _{OSC2} = 4 MHz	f _{OSC2} = 8 MHz		
16000	4ms	2ms	0	0
32000	8ms	4ms	0	1
80000	20ms	10ms	1	0
200000	50ms	25ms	1	1

11.8.2 MCC beep control register (MCCBCR)

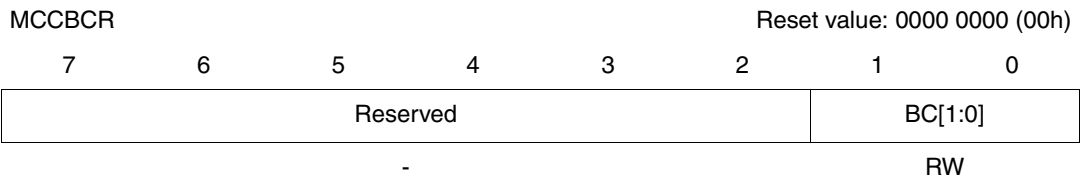

Table 42. MCCBCR register description

Bit	Name	Function
7:2	-	Reserved, must be kept cleared.
1:0	BC[1:0]	<p><i>Beep control</i></p> <p>These 2 bits select the PF1 pin beep capability (see Table 43).</p>

Table 43. Beep frequency selection

BC1	BC0	Beep mode with f _{OSC2} = 8 MHz	
0	0	Off	
0	1	~2 kHz	Output Beep signal ~50% duty cycle
1	0	~1 kHz	
1	1	~500 Hz	

The beep output signal is available in Active Halt mode but has to be disabled to reduce consumption.

Table 44. Main clock controller register map and reset values

Address (Hex.)	Register label	7	6	5	4	3	2	1	0
002Bh	SICSR Reset value	AVDS 0	AVDIE 0	AVDF 0	LVDRF x	0	0	0	WDGRF x
002Ch	MCCSR Reset value	MCO 0	CP1 0	CP0 0	SMS 0	TB1 0	TB0 0	OIE 0	OIF 0
002Dh	MCCBCR Reset value	0	0	0	0	0	0	BC1 0	BC0 0

12 PWM auto-reload timer (ART)

12.1 Introduction

The Pulse Width Modulated Auto-Reload Timer on-chip peripheral consists of an 8-bit auto-reload counter with compare/capture capabilities and of a 7-bit prescaler clock source.

These resources allow five possible operating modes:

- Generation of up to 4 independent PWM signals
- Output compare and Time base interrupt
- Up to 2 input capture functions
- External event detector
- Up to 2 external interrupt sources

The three first modes can be used together with a single counter frequency.

The timer can be used to wake up the MCU from Wait and Halt modes.

Figure 35. PWM auto-reload timer block diagram

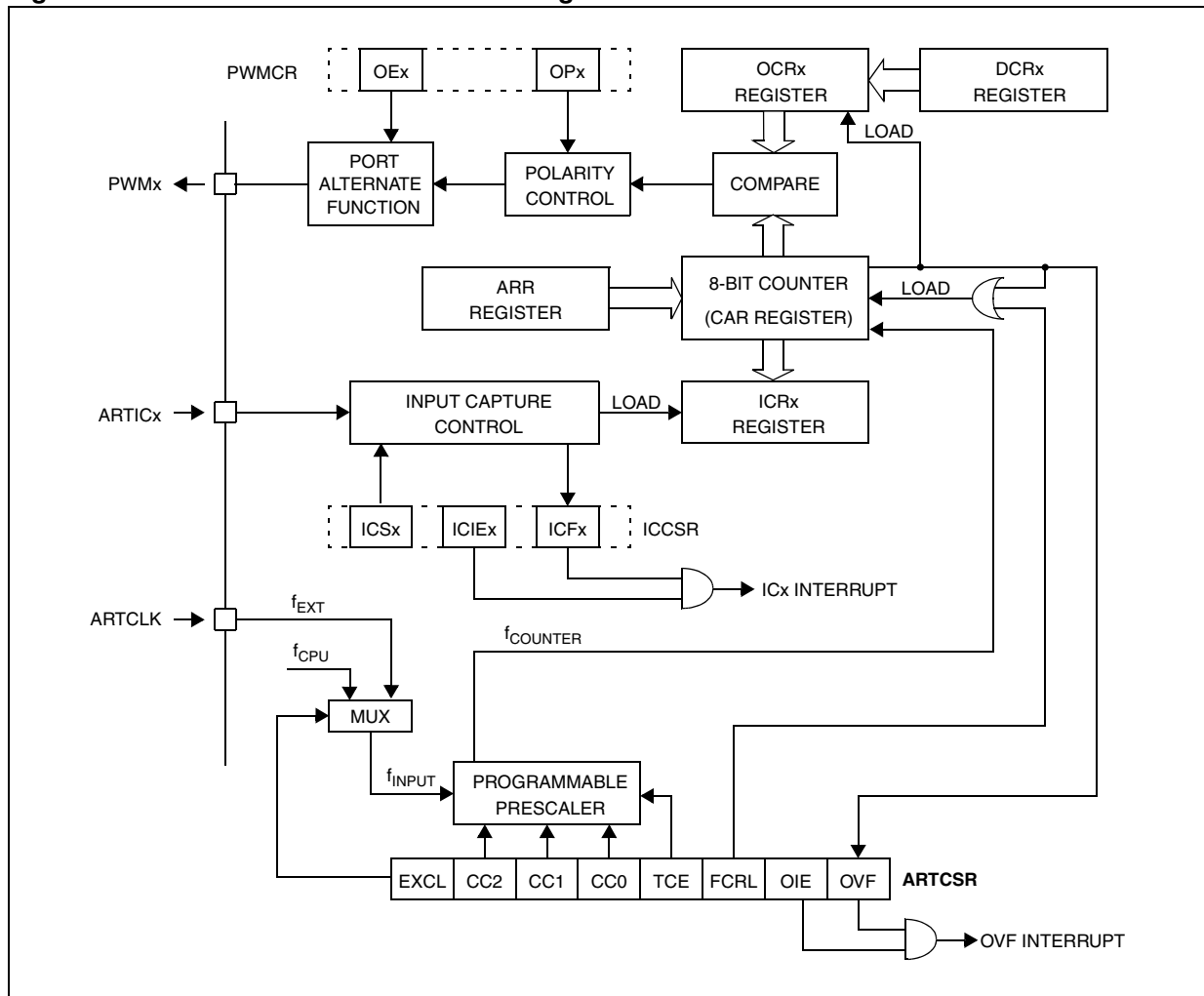

12.2 Functional description

12.2.1 Counter

The free running 8-bit counter is fed by the output of the prescaler, and is incremented on every rising edge of the clock signal.

It is possible to read or write the contents of the counter on the fly by reading or writing the Counter Access register (ARTCAR).

When a counter overflow occurs, the counter is automatically reloaded with the contents of the ARTARR register (the prescaler is not affected).

12.2.2 Counter clock and prescaler

The counter clock frequency is given by:

$$f_{\text{COUNTER}} = f_{\text{INPUT}} / 2^{\text{CC}[2:0]}$$

The timer counter's input clock (f_{INPUT}) feeds the 7-bit programmable prescaler, which selects one of the 8 available taps of the prescaler, as defined by CC[2:0] bits in the Control/Status Register (ARTCSR). Thus the division factor of the prescaler can be set to 2^n (where $n = 0, 1, \dots, 7$).

This f_{INPUT} frequency source is selected through the EXCL bit of the ARTCSR register and can be either the f_{CPU} or an external input frequency f_{EXT} .

The clock input to the counter is enabled by the TCE (Timer Counter Enable) bit in the ARTCSR register. When TCE is reset, the counter is stopped and the prescaler and counter contents are frozen. When TCE is set, the counter runs at the rate of the selected clock source.

12.2.3 Counter and prescaler initialization

After RESET, the counter and the prescaler are cleared and $f_{\text{INPUT}} = f_{\text{CPU}}$.

The counter can be initialized by:

- writing to the ARTARR register and then setting the FCRL (Force Counter Re-Load) and the TCE (Timer Counter Enable) bits in the ARTCSR register
- writing to the ARTCAR counter access register

In both cases the 7-bit prescaler is also cleared, whereupon counting will start from a known value.

Direct access to the prescaler is not possible.

12.2.4 Output compare control

The timer compare function is based on four different comparisons with the counter (one for each PWMx output). Each comparison is made between the counter value and an output compare register (OCRx) value. This OCRx register can not be accessed directly, it is loaded from the duty cycle register (PWMDCRx) at each overflow of the counter.

This double buffering method avoids glitch generation when changing the duty cycle on the fly.

Figure 36. Output compare control

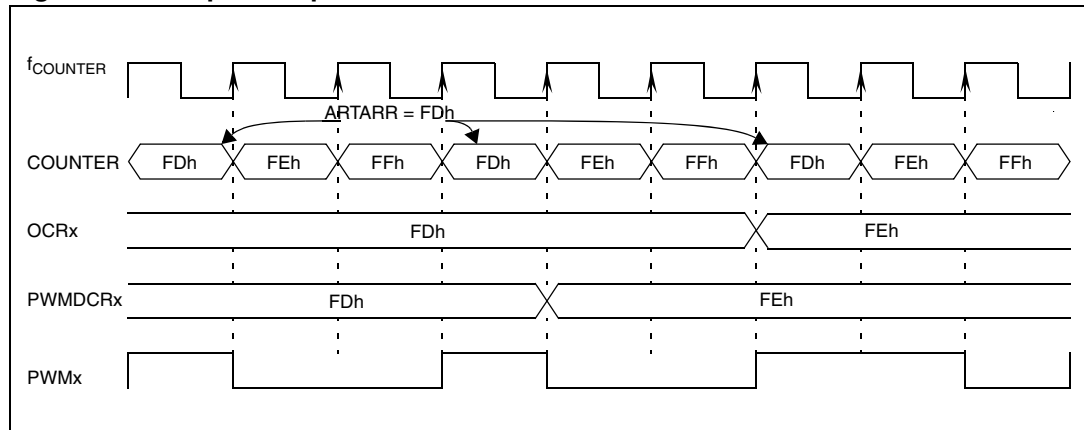

12.2.5 Independent PWM signal generation

This mode allows up to four Pulse Width Modulated signals to be generated on the PWMx output pins with minimum core processing overhead. This function is stopped during Halt mode.

Each PWMx output signal can be selected independently using the corresponding OEx bit in the PWM Control register (PWMCR). When this bit is set, the corresponding I/O pin is configured as output push-pull alternate function.

The PWM signals all have the same frequency which is controlled by the counter period and the ARTARR register value.

$$f_{PWM} = f_{COUNTER} / (256 - ARTARR)$$

When a counter overflow occurs, the PWMx pin level is changed depending on the corresponding OPx (output polarity) bit in the PWMCR register. When the counter reaches the value contained in one of the output compare register (OCRx) the corresponding PWMx pin level is restored.

It should be noted that the reload values will also affect the value and the resolution of the duty cycle of the PWM output signal. To obtain a signal on a PWMx pin, the contents of the OCRx register must be greater than the contents of the ARTARR register.

The maximum available resolution for the PWMx duty cycle is:

$$\text{Resolution} = 1 / (256 - ARTARR)$$

Note: To get the maximum resolution (1/256), the ARTARR register must be 0. With this maximum resolution, 0% and 100% can be obtained by changing the polarity.

Figure 37. PWM auto-reload timer function

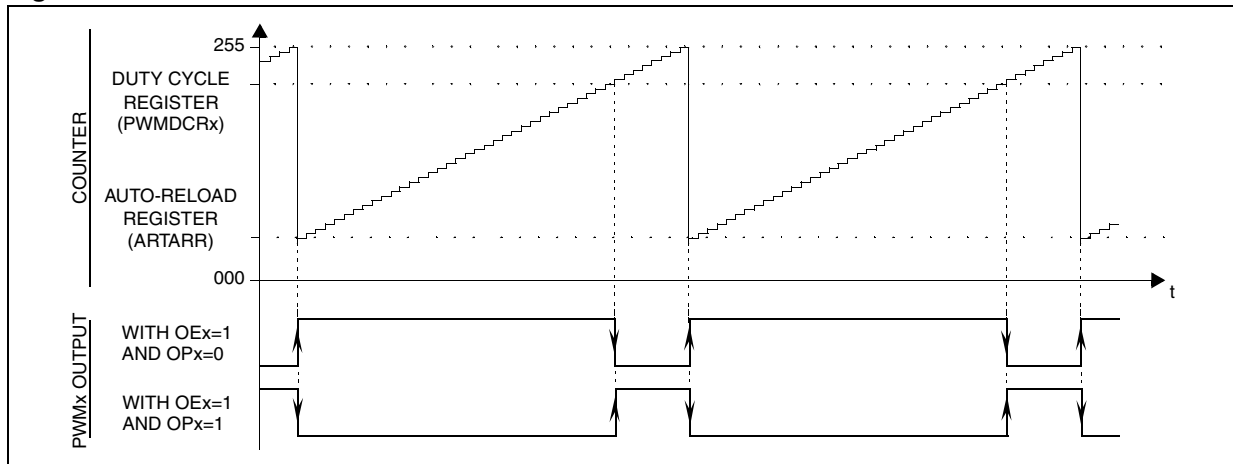
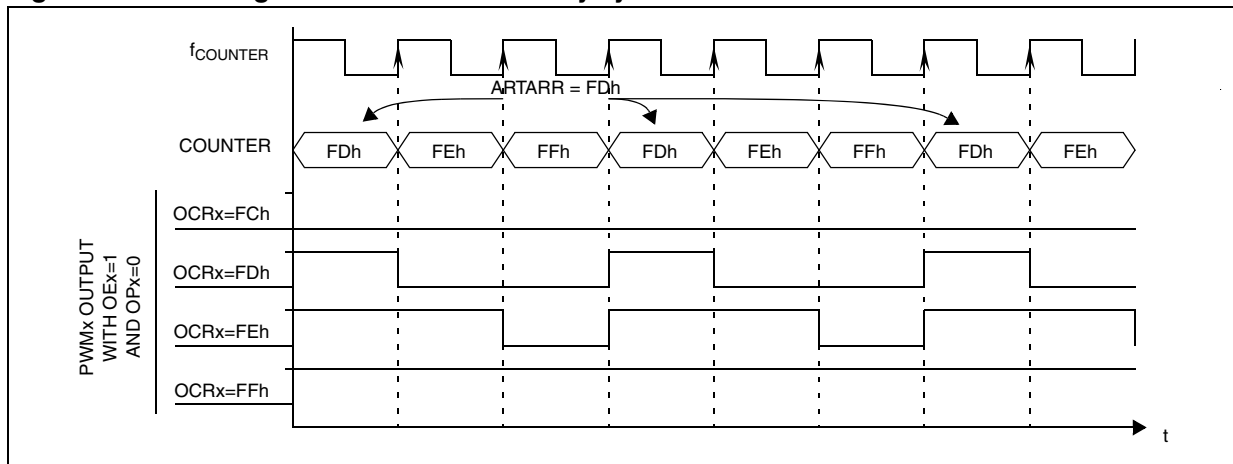

Figure 38. PWM signal from 0% to 100% duty cycle



12.2.6 Output compare and time base interrupt

On overflow, the OVF flag of the ARTCSR register is set and an overflow interrupt request is generated if the overflow interrupt enable bit, OIE, in the ARTCSR register, is set. The OVF flag must be reset by the user software. This interrupt can be used as a time base in the application.

12.2.7 External clock and event detector mode

Using the f_{EXT} external prescaler input clock, the auto-reload timer can be used as an external clock event detector. In this mode, the ARTARR register is used to select the n_{EVENT} number of events to be counted before setting the OVF flag.

$$n_{EVENT} = 256 - ARTARR$$

Caution: The external clock function is not available in Halt mode. If Halt mode is used in the application, prior to executing the HALT instruction, the counter must be disabled by clearing the TCE bit in the ARTCSR register to avoid spurious counter increments.

Figure 39. External event detector example (3 counts)

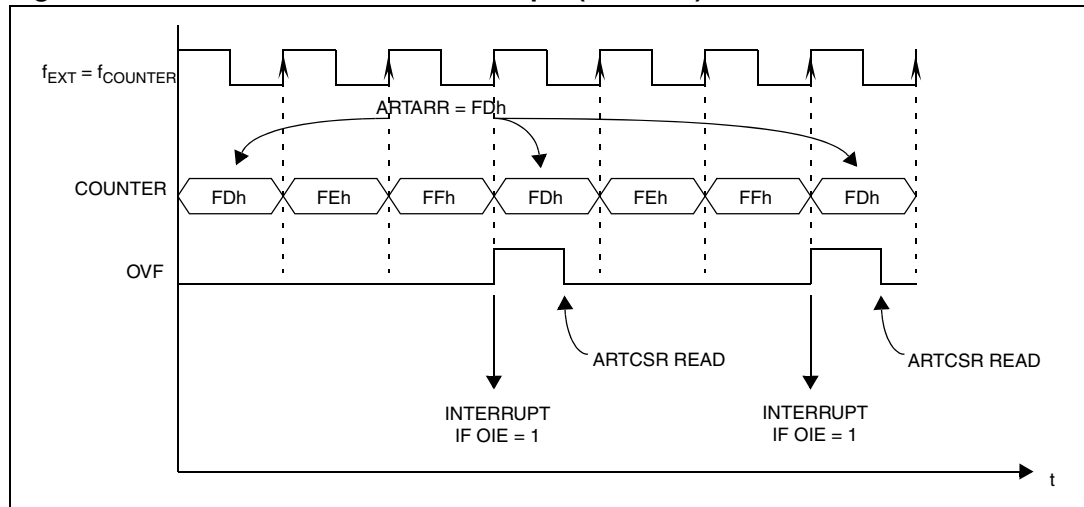

12.2.8 Input capture function

This mode allows the measurement of external signal pulse widths through ARTICRx registers.

Each input capture can generate an interrupt independently on a selected input signal transition. This event is flagged by a set of the corresponding CFx bits of the Input Capture Control/Status register (ARTICCSR).

These input capture interrupts are enabled through the CIEx bits of the ARTICCSR register.

The active transition (falling or rising edge) is software programmable through the CSx bits of the ARTICCSR register.

The read only input capture registers (ARTICRx) are used to latch the auto-reload counter value when a transition is detected on the ARTICx pin (CFx bit set in ARTICCSR register). After fetching the interrupt vector, the CFx flags can be read to identify the interrupt source.

Note: After a capture detection, data transfer in the ARTICRx register is inhibited until it is read (clearing the CFx bit).

The timer interrupt remains pending while the CFx flag is set when the interrupt is enabled (CIEx bit set). This means that the ARTICRx register has to be read at each capture event to clear the CFx flag.

The timing resolution is given by auto-reload counter cycle time ($1/f_{\text{COUNTER}}$).

Note: During Halt mode, if both the input capture and the external clock are enabled, the ARTICRx register value is not guaranteed if the input capture pin and the external clock change simultaneously.

12.2.9 External interrupt capability

This mode allows the input capture capabilities to be used as external interrupt sources. The interrupts are generated on the edge of the ARTICx signal.

The edge sensitivity of the external interrupts is programmable (CSx bit of ARTICCSR register) and they are independently enabled through CIEx bits of the ARTICCSR register. After fetching the interrupt vector, the CFx flags can be read to identify the interrupt source.

During Halt mode, the external interrupts can be used to wake up the micro (if the CIEx bit is set).

Figure 40. Input capture timing diagram

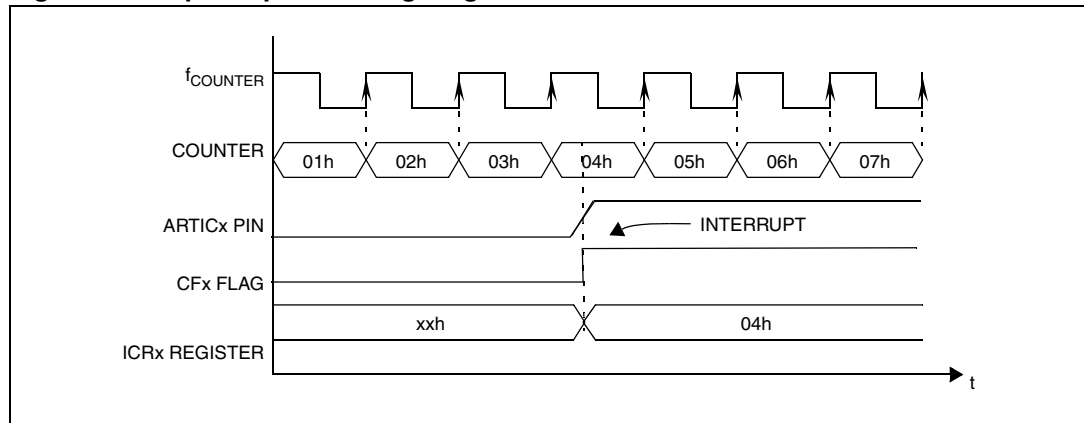

12.3 ART registers

12.3.1 Control/status register (ARTCSR)

ARTCSR Reset value: 0000 0000 (00h)

7	6	5	4	3	2	1	0
EXCL	CC[2:0]			TCE	FCRL	OIE	OVF
RW	RW			RW	RW	RW	RW

Table 45. ARTCSR register description

Bit	Name	Function
7	EXCL	<p><i>External Clock</i></p> <p>This bit is set and cleared by software. It selects the input clock for the 7-bit prescaler.</p> <p>0: CPU clock 1: External clock</p>
6:4	CC[2:0]	<p><i>Counter Clock Control</i></p> <p>These bits are set and cleared by software. They determine the prescaler division ratio from f_{INPUT} (see Table 46).</p>
3	TCE	<p><i>Timer Counter Enable</i></p> <p>This bit is set and cleared by software. It puts the timer in the lowest power consumption mode.</p> <p>0: Counter stopped (prescaler and counter frozen) 1: Counter running</p>
2	FCRL	<p><i>Force Counter Re-Load</i></p> <p>This bit is write-only and any attempt to read it will yield a logical zero. When set, it causes the contents of ARTARR register to be loaded into the counter, and the content of the prescaler register to be cleared in order to initialize the timer before starting to count.</p>
1	OIE	<p><i>Overflow Interrupt Enable</i></p> <p>This bit is set and cleared by software. It allows to enable/disable the interrupt which is generated when the OVF bit is set.</p> <p>0: Overflow Interrupt disable 1: Overflow Interrupt enable</p>
0	OVF	<p><i>Overflow Flag</i></p> <p>This bit is set by hardware and cleared by software reading the ARTCSR register. It indicates the transition of the counter from FFh to the ARTARR value.</p> <p>0: New transition not yet reached 1: Transition reached</p>

Table 46. Prescaler selection for ART

f _{COUNTER}	With f _{INPUT} = 8 MHz	CC2	CC1	CC0
f _{INPUT}	8 MHz	0	0	0
f _{INPUT} / 2	4 MHz	0	0	1
f _{INPUT} / 4	2 MHz	0	1	0

Table 46. Prescaler selection for ART (continued)

f_{COUNTER}	With $f_{\text{INPUT}} = 8 \text{ MHz}$	CC2	CC1	CC0
$f_{\text{INPUT}} / 8$	1 MHz	0	1	1
$f_{\text{INPUT}} / 16$	500 kHz	1	0	0
$f_{\text{INPUT}} / 32$	250 kHz	1	0	1
$f_{\text{INPUT}} / 64$	125 kHz	1	1	0
$f_{\text{INPUT}} / 128$	62.5 kHz	1	1	1

12.3.2 Counter access register (ARTCAR)

ARTCAR Reset value: 0000 0000 (00h)

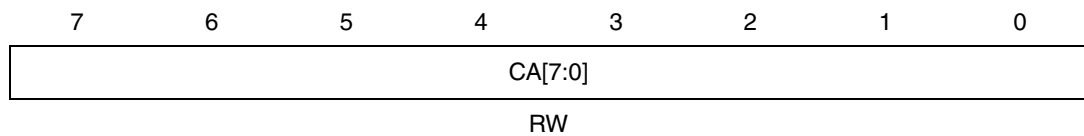

Table 47. ARTCAR register description

Bit	Name	Function
7:0	CA[7:0]	<i>Counter Access Data</i> These bits can be set and cleared either by hardware or by software. The ARTCAR register is used to read or write the auto-reload counter “on the fly” (while it is counting).

12.3.3 Auto-reload register (ARTARR)

ARTARR Reset value: 0000 0000 (00h)

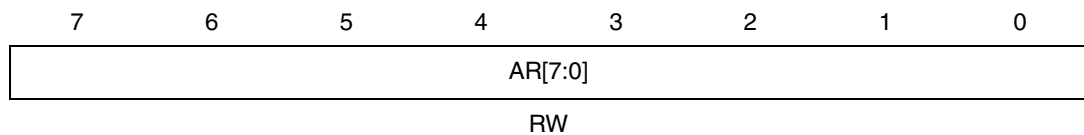

Table 48. ARTAAR register description

Bit	Name	Function
7:0	AR[7:0]	<i>Counter Auto-Reload Data</i> These bits are set and cleared by software. They are used to hold the auto-reload value which is automatically loaded in the counter when an overflow occurs. At the same time, the PWM output levels are changed according to the corresponding OPx bit in the PWMCR register.

This register has two PWM management functions:

- Adjusting the PWM frequency
- Setting the PWM duty cycle resolution

Table 49. PWM frequency versus resolution

ARTARR value	Resolution	f _{PWM}	
		Min	Max
0	8-bit	~0.244 kHz	31.25 kHz
[0..127]	> 7-bit	~0.244 kHz	62.5 kHz
[128..191]	> 6-bit	~0.488 kHz	125 kHz
[192..223]	> 5-bit	~0.977 kHz	250 kHz
[224..239]	> 4-bit	~1.953 kHz	500 kHz

12.3.4 PWM control register (PWMCR)

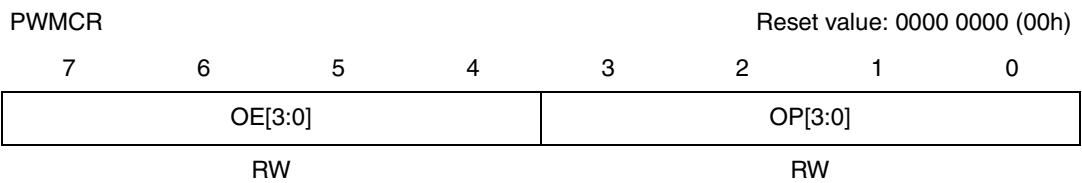

Table 50. PWMCR register description

Bit	Name	Function
7:4	OE[3:0]	<i>PWM Output Enable</i> These bits are set and cleared by software. They enable or disable the PWM output channels independently acting on the corresponding I/O pin. 0: PWM output disabled 1: PWM output enabled
3:0	OP[3:0]	<i>PWM Output Polarity</i> These bits are set and cleared by software. They independently select the polarity of the four PWM output signals (see Table 51).

Table 51. PWM output signal polarity selection

PWMx output level		OPx ⁽¹⁾
Counter ≤ OCRx	Counter > OCRx	
1	0	0
0	1	1

1. When an OPx bit is modified, the PWMx output signal polarity is immediately reversed.

12.3.5 Duty cycle registers (PWMDCRx)

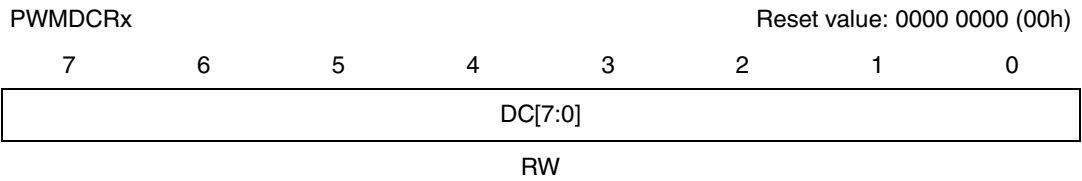

Table 52. PWMDCRx register description

Bit	Name	Function
7:0	DC[7:0]	<i>Duty Cycle Data</i> These bits are set and cleared by software.

A PWMDCRx register is associated with the OCRx register of each PWM channel to determine the second edge location of the PWM signal (the first edge location is common to all channels and given by the ARTARR register). These PWMDCR registers allow the duty cycle to be set independently for each PWM channel.

12.3.6 Input capture control / status register (ARTICCSR)

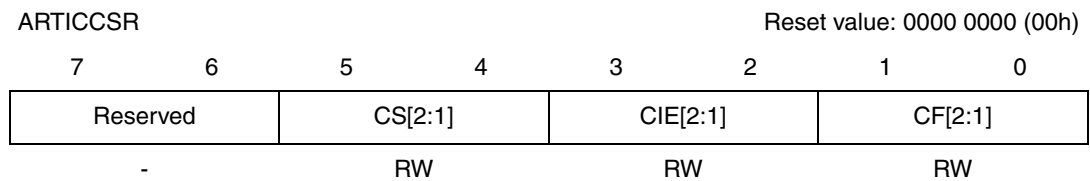

Table 53. ARTICCSR register description

Bit	Name	Function
7:6	-	Reserved, always read as 0.
5:4	CS[2:1]	<i>Capture Sensitivity</i> These bits are set and cleared by software. They determine the trigger event polarity on the corresponding input capture channel. 0: Falling edge triggers capture on channel x 1: Rising edge triggers capture on channel x
3:2	CIE[2:1]	<i>Capture Interrupt Enable</i> These bits are set and cleared by software. They enable or disable the Input capture channel interrupts independently. 0: Input capture channel x interrupt disabled 1: Input capture channel x interrupt enabled
1:0	CF[2:1]	<i>Capture Flag</i> These bits are set by hardware and cleared by software reading the corresponding ARTICRx register. Each CFx bit indicates that an input capture x has occurred. 0: No input capture on channel x 1: An input capture has occurred on channel x.

12.3.7 Input capture registers (ARTICRx)

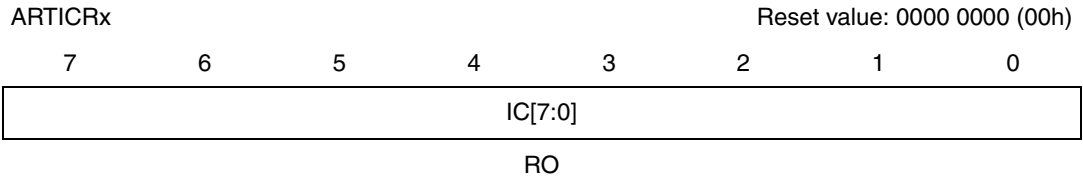

Table 54. ARTICRx register description

Bit	Name	Function
7:0	IC[7:0]	<i>Input Capture Data</i> These read only bits are set and cleared by hardware. An ARTICRx register contains the 8-bit auto-reload counter value transferred by the input capture channel x event.

Table 55. PWM auto-reload timer register map and reset values

Address (Hex.)	Register label	7	6	5	4	3	2	1	0
0073h	PWMDCR3 Reset value	DC7 0	DC6 0	DC5 0	DC4 0	DC3 0	DC2 0	DC1 0	DC0 0
0074h	PWMDCR2 Reset value	DC7 0	DC6 0	DC5 0	DC4 0	DC3 0	DC2 0	DC1 0	DC0 0
0075h	PWMDCR1 Reset value	DC7 0	DC6 0	DC5 0	DC4 0	DC3 0	DC2 0	DC1 0	DC0 0
0076h	PWMDCR0 Reset value	DC7 0	DC6 0	DC5 0	DC4 0	DC3 0	DC2 0	DC1 0	DC0 0
0077h	PWMCR Reset value	OE3 0	OE2 0	OE1 0	OE0 0	OP3 0	OP2 0	OP1 0	OP0 0
0078h	ARTCSR Reset value	EXCL 0	CC2 0	CC1 0	CC0 0	TCE 0	FCRL 0	RIE 0	OVF 0
0079h	ARTCAR Reset value	CA7 0	CA6 0	CA5 0	CA4 0	CA3 0	CA2 0	CA1 0	CA0 0
007Ah	ARTARR Reset value	AR7 0	AR6 0	AR5 0	AR4 0	AR3 0	AR2 0	AR1 0	AR0 0
007Bh	ARTICCSR Reset value	0	0	CS2 0	CS1 0	CIE2 0	CIE1 0	CF2 0	CF1 0
007Ch	ARTICR1 Reset value	IC7 0	IC6 0	IC5 0	IC4 0	IC3 0	IC2 0	IC1 0	IC0 0
007Dh	ARTICR2 Reset value	IC7 0	IC6 0	IC5 0	IC4 0	IC3 0	IC2 0	IC1 0	IC0 0

13 16-bit timer

13.1 Introduction

The timer consists of a 16-bit free-running counter driven by a programmable prescaler.

It may be used for a variety of purposes, including pulse length measurement of up to two input signals (input capture) or generation of up to two output waveforms (output compare and PWM).

Pulse lengths and waveform periods can be modulated from a few microseconds to several milliseconds using the timer prescaler and the CPU clock prescaler.

Some ST7 devices have two on-chip 16-bit timers. They are completely independent, and do not share any resources. They are synchronized after an MCU reset as long as the timer clock frequencies are not modified.

This description covers one or two 16-bit timers. In ST7 devices with two timers, register names are prefixed with TA (Timer A) or TB (Timer B).

13.2 Main features

- Programmable prescaler: f_{CPU} divided by 2, 4 or 8
- Overflow status flag and maskable interrupt
- External clock input (must be at least four times slower than the CPU clock speed) with the choice of active edge
- 1 or 2 Output Compare functions each with:
 - 2 dedicated 16-bit registers
 - 2 dedicated programmable signals
 - 2 dedicated status flags
 - 1 dedicated maskable interrupt
- 1 or 2 Input Capture functions each with:
 - 2 dedicated 16-bit registers
 - 2 dedicated active edge selection signals
 - 2 dedicated status flags
 - 1 dedicated maskable interrupt
- Pulse Width Modulation mode (PWM)
- One Pulse mode
- Reduced Power mode
- 5 alternate functions on I/O ports (ICAP1, ICAP2, OCMP1, OCMP2, EXTCLK)^(a)

The block diagram is shown in [Figure 41](#).

Note: When reading an input signal on a non-bonded pin, the value will always be '1'.

a. Some timer pins may not be available (not bonded) in some ST7 devices. Refer to the device pinout description.

13.3 Functional description

13.3.1 Counter

The main block of the Programmable Timer is a 16-bit free running upcounter and its associated 16-bit registers. The 16-bit registers are made up of two 8-bit registers called high and low.

Counter Register (CR)

- Counter High Register (CHR) is the most significant byte (MS Byte)
- Counter Low Register (CLR) is the least significant byte (LS Byte)

Alternate Counter Register (ACR)

- Alternate Counter High Register (ACHR) is the most significant byte (MS Byte)
- Alternate Counter Low Register (ACLR) is the least significant byte (LS Byte)

These two read-only 16-bit registers contain the same value but with the difference that reading the ACLR register does not clear the TOF bit (Timer overflow flag), located in the Status register (SR) (see note at the end of paragraph entitled [16-bit read sequence](#)).

Writing in the CLR register or ACLR register resets the free running counter to the FFFCh value.

Both counters have a reset value of FFFCh (this is the only value which is reloaded in the 16-bit timer). The reset value of both counters is also FFFCh in One Pulse mode and PWM mode.

The timer clock depends on the clock control bits of the CR2 register, as illustrated in [Table 61: Timer clock selection](#). The value in the counter register repeats every 131072, 262144 or 524288 CPU clock cycles depending on the CC[1:0] bits.

The timer frequency can be $f_{CPU}/2$, $f_{CPU}/4$, $f_{CPU}/8$ or an external frequency.

Figure 41. Timer block diagram

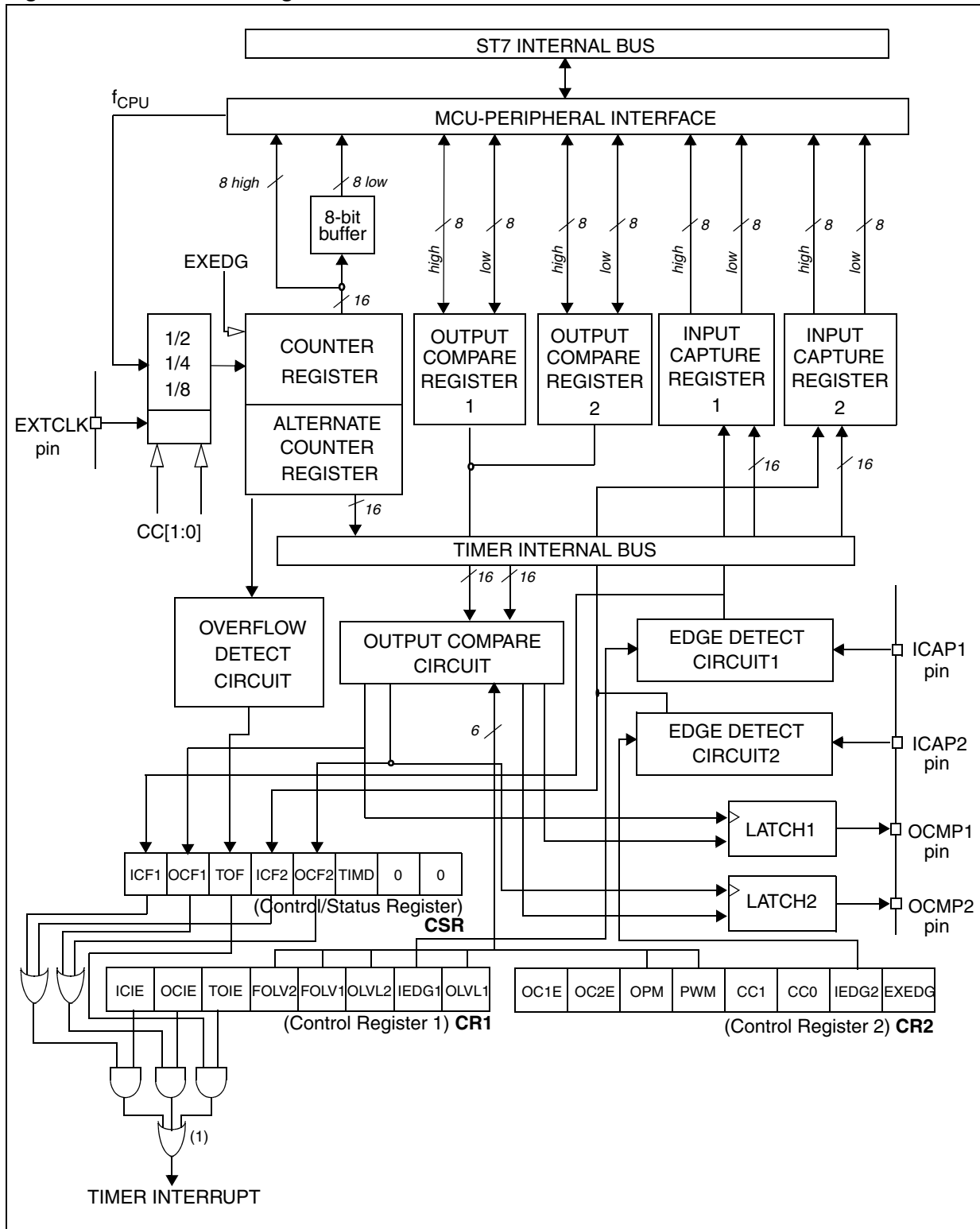

1. If IC, OC and TO interrupt request have separate vectors, then the last OR is not present (see device interrupt vector table).

16-bit read sequence

The 16-bit read sequence (from either the Counter Register or the Alternate Counter Register) is illustrated in [Figure 42](#).

Figure 42. 16-bit read sequence

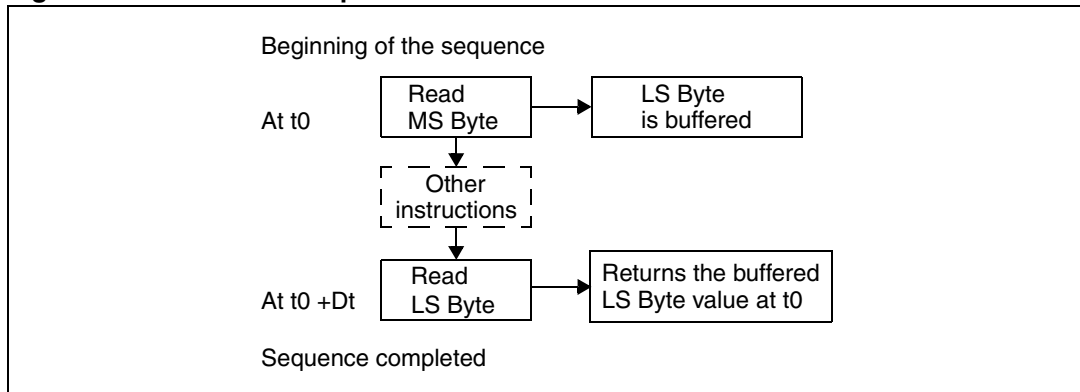

The user must read the MS Byte first; the LS Byte value is then buffered automatically.

This buffered value remains unchanged until the 16-bit read sequence is completed, even if the user reads the MS Byte several times.

After a complete reading sequence, if only the CLR register or ACLR register are read, they return the LS Byte of the count value at the time of the read.

Whatever timer mode is used (input capture, output compare, one pulse mode or PWM mode) an overflow occurs when the counter rolls over from FFFFh to 0000h, after which

- the TOF bit of the SR register is set
- a timer interrupt is generated if
 - the TOIE bit of the CR1 register is set and
 - the I bit of the CC register is cleared

If one of these conditions is false, the interrupt remains pending to be issued as soon as they are both true.

Clearing the overflow interrupt request is done in two steps:

1. Reading the SR register while the TOF bit is set
2. An access (read or write) to the CLR register

Note: The TOF bit is not cleared by accesses to ACLR register. The advantage of accessing the ACLR register rather than the CLR register is that it allows simultaneous use of the overflow function and reading the free running counter at random times (for example, to measure elapsed time) without the risk of clearing the TOF bit erroneously.

The timer is not affected by Wait mode.

In Halt mode, the counter stops counting until the mode is exited. Counting then resumes from the previous count (MCU awakened by an interrupt) or from the reset count (MCU awakened by a Reset).

13.3.2 External clock

The external clock (where available) is selected if CC0 = 1 and CC1 = 1 in the CR2 register.

The status of the EXEDG bit in the CR2 register determines the type of level transition on the external clock pin EXTCLK that will trigger the free running counter.

The counter is synchronized with the falling edge of the internal CPU clock.

A minimum of four falling edges of the CPU clock must occur between two consecutive active edges of the external clock; thus, the external clock frequency must be less than a quarter of the CPU clock frequency.

Figure 43. Counter timing diagram, internal clock divided by 2

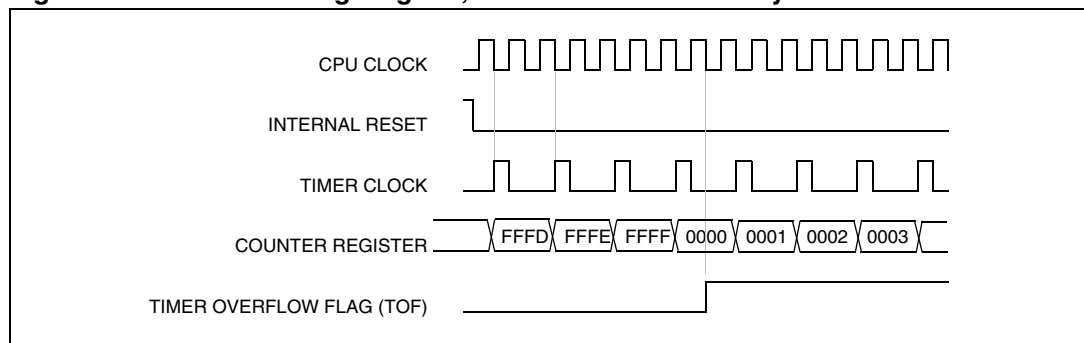

Figure 44. Counter timing diagram, internal clock divided by 4

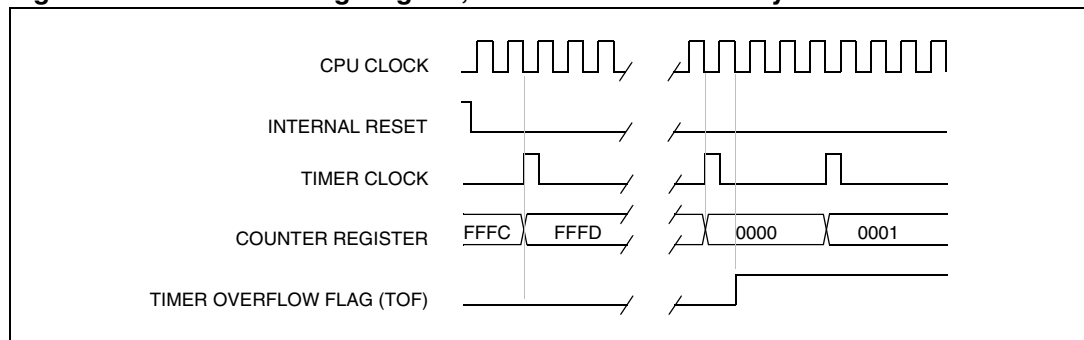
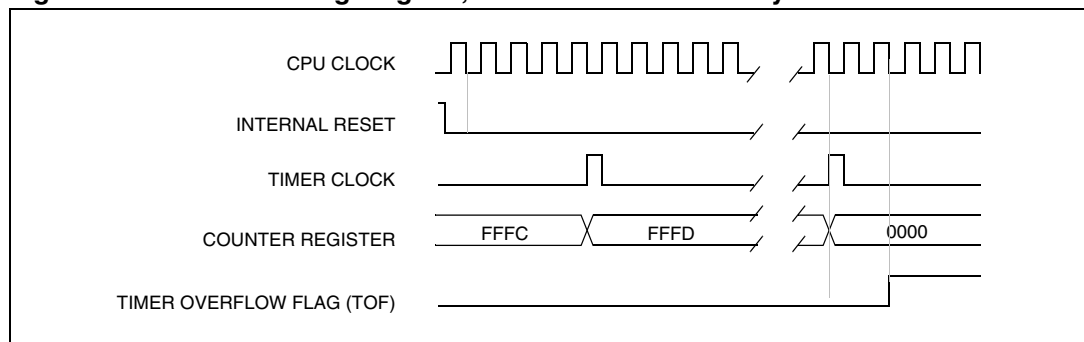

Figure 45. Counter timing diagram, internal clock divided by 8



Note: The MCU is in reset state when the internal reset signal is high; when it is low the MCU is running.

13.3.3 Input capture

In this section, the index, i , may be 1 or 2 because there are two input capture functions in the 16-bit timer.

The two 16-bit input capture registers (IC1R and IC2R) are used to latch the value of the free running counter after a transition is detected on the ICAP i pin (see [Figure 46](#)).

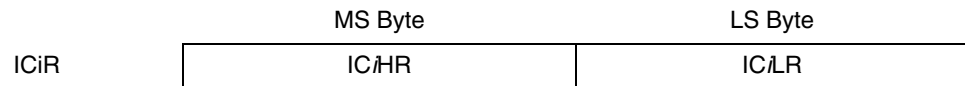

IC i R register is a read-only register.

The active transition is software programmable through the IEDG i bit of Control Registers (CR i).

Timing resolution is one count of the free running counter: ($f_{CPU}/CC[1:0]$).

Procedure:

To use the input capture function select the following in the CR2 register:

- Select the timer clock (CC[1:0]) (see [Table 61: Timer clock selection](#)).
- Select the edge of the active transition on the ICAP2 pin with the IEDG2 bit (the ICAP2 pin must be configured as floating input or input with pull-up without interrupt if this configuration is available).

And select the following in the CR1 register:

- Set the ICIE bit to generate an interrupt after an input capture coming from either the ICAP1 pin or the ICAP2 pin
- Select the edge of the active transition on the ICAP1 pin with the IEDG1 bit (the ICAP1 pin must be configured as floating input or input with pull-up without interrupt if this configuration is available).

When an input capture occurs:

- ICF i bit is set.
- The IC i R register contains the value of the free running counter on the active transition on the ICAP i pin (see [Figure 47](#)).
- A timer interrupt is generated if the ICIE bit is set and the I bit is cleared in the CC register. Otherwise, the interrupt remains pending until both conditions become true.

Clearing the input capture interrupt request (that is, clearing the ICF i bit) is done in two steps:

1. Reading the SR register while the ICF i bit is set
2. An access (read or write) to the IC i LR register

- Note:**
- 1 After reading the IC i HR register, transfer of input capture data is inhibited and ICF i will never be set until the IC i LR register is also read.
 - 2 The IC i R register contains the free running counter value which corresponds to the most recent input capture.
 - 3 The two input capture functions can be used together even if the timer also uses the two output compare functions.
 - 4 In One pulse Mode and PWM mode only Input Capture 2 can be used.

- 5 The alternate inputs (ICAP1 and ICAP2) are always directly connected to the timer. So any transitions on these pins activates the input capture function.
- 6 Moreover if one of the ICAPi pins is configured as an input and the second one as an output, an interrupt can be generated if the user toggles the output pin and if the ICIE bit is set.
- 7 This can be avoided if the input capture function i is disabled by reading the ICiHR (see note 1).
- 8 The TOF bit can be used with interrupt generation in order to measure events that go beyond the timer range (FFFFh).

Figure 46. Input capture block diagram

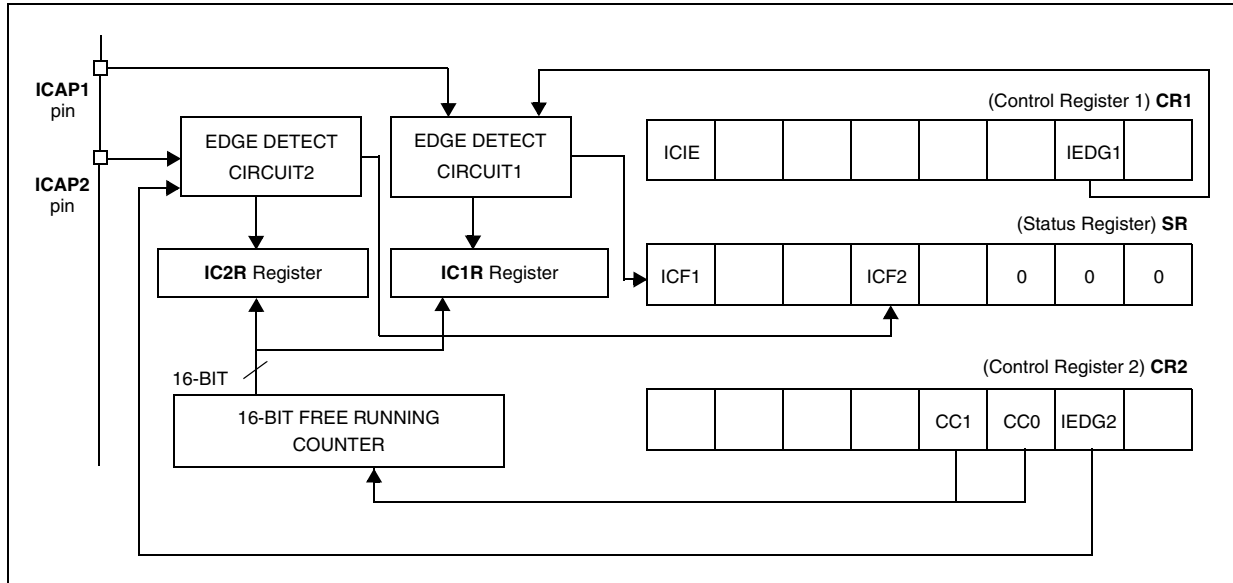
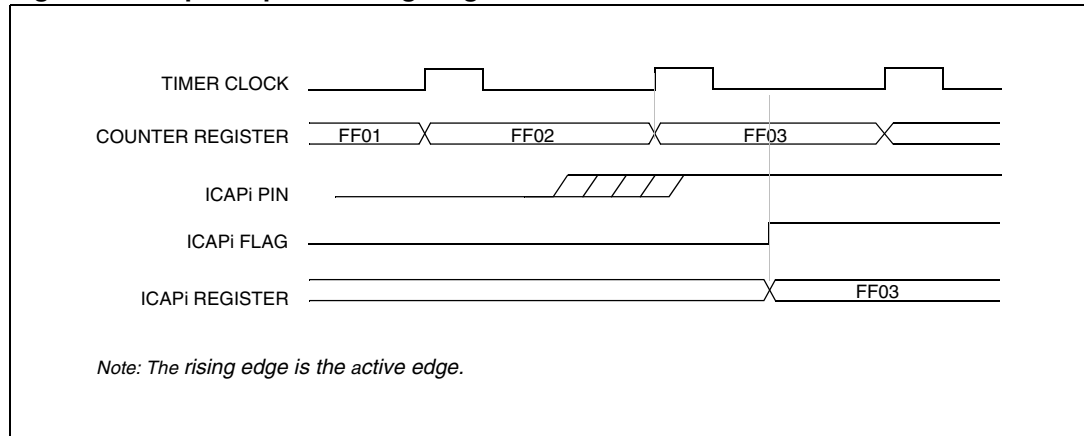

Figure 47. Input capture timing diagram



13.3.4 Output compare

In this section, the index, *i*, may be 1 or 2 because there are two output compare functions in the 16-bit timer.

This function can be used to control an output waveform or indicate when a period of time has elapsed.

When a match is found between the Output Compare register and the free running counter, the output compare function:

- Assigns pins with a programmable value if the OC/E bit is set
- Sets a flag in the status register
- Generates an interrupt if enabled

Two 16-bit registers Output Compare Register 1 (OC1R) and Output Compare Register 2 (OC2R) contain the value to be compared to the counter register each timer clock cycle.

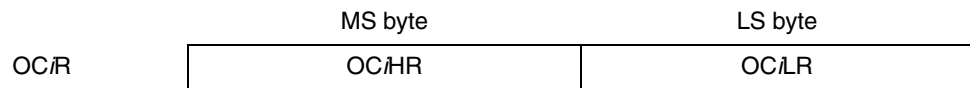

These registers are readable and writable and are not affected by the timer hardware. A reset event changes the OC*R* value to 8000h.

Timing resolution is one count of the free running counter: ($f_{CPU}/CC[1:0]$).

Procedure

To use the output compare function, select the following in the CR2 register:

- Set the OC/E bit if an output is needed then the OCMP*i* pin is dedicated to the output compare *i* signal.
- Select the timer clock (CC[1:0]) (see [Table 61: Timer clock selection](#)).

And select the following in the CR1 register:

- Select the OLVL*i* bit to applied to the OCMP*i* pins after the match occurs.
- Set the OCIE bit to generate an interrupt if it is needed.

When a match is found between OCR*i* register and CR register:

- OCF*i* bit is set.
- The OCMP*i* pin takes OLVL*i* bit value (OCMP*i* pin latch is forced low during reset).
- A timer interrupt is generated if the OCIE bit is set in the CR1 register and the I bit is cleared in the CC register (CC).

The OC*R* register value required for a specific timing application can be calculated using the following formula:

$$\Delta OC/R = \frac{\Delta t \cdot f_{CPU}}{PRESC}$$

Where:

Δt = Output compare period (in seconds)

f_{CPU} = CPU clock frequency (in hertz)

PRESC = Timer prescaler factor (2, 4 or 8 depending on CC[1:0] bits; see [Table 61: Timer clock selection](#))

If the timer clock is an external clock, the formula is:

$$\Delta \text{OCiR} = \Delta t * f_{\text{EXT}}$$

Where:

- Δt = Output compare period (in seconds)
- f_{CPU} = External timer clock frequency (in hertz)

Clearing the output compare interrupt request (that is, clearing the OCF i bit) is done by:

1. Reading the SR register while the OCF i bit is set
2. An access (read or write) to the OCiLR register

The following procedure is recommended to prevent the OCF i bit from being set between the time it is read and the write to the OCiR register:

- Write to the OCiHR register (further compares are inhibited).
- Read the SR register (first step of the clearance of the OCF i bit, which may be already set).
- Write to the OCiLR register (enables the output compare function and clears the OCF i bit).

- Note:*
- 1 After a processor write cycle to the OCiHR register, the output compare function is inhibited until the OCiLR register is also written.
 - 2 If the OCiE bit is not set, the OCMPi pin is a general I/O port and the OLVLi bit will not appear when a match is found but an interrupt could be generated if the OCiE bit is set.
 - 3 In both internal and external clock modes, OCF i and OCMPi are set while the counter value equals the OCiR register value (see [Figure 49 on page 107](#) for an example with $f_{\text{CPU}}/2$ and [Figure 50 on page 107](#) for an example with $f_{\text{CPU}}/4$). This behavior is the same in OPM or PWM mode.
 - 4 The output compare functions can be used both for generating external events on the OCMPi pins even if the input capture mode is also used.
 - 5 The value in the 16-bit OCiR register and the OLVi bit should be changed after each successful comparison in order to control an output waveform or establish a new elapsed timeout.

13.3.5 Forced compare output capability

When the FOLVi bit is set by software, the OLVLi bit is copied to the OCMPi pin. The OLVi bit has to be toggled in order to toggle the OCMPi pin when it is enabled (OCiE bit = 1). The OCFi bit is then not set by hardware, and thus no interrupt request is generated.

The FOLVLi bits have no effect in both one pulse mode and PWM mode.

Figure 48. Output compare block diagram

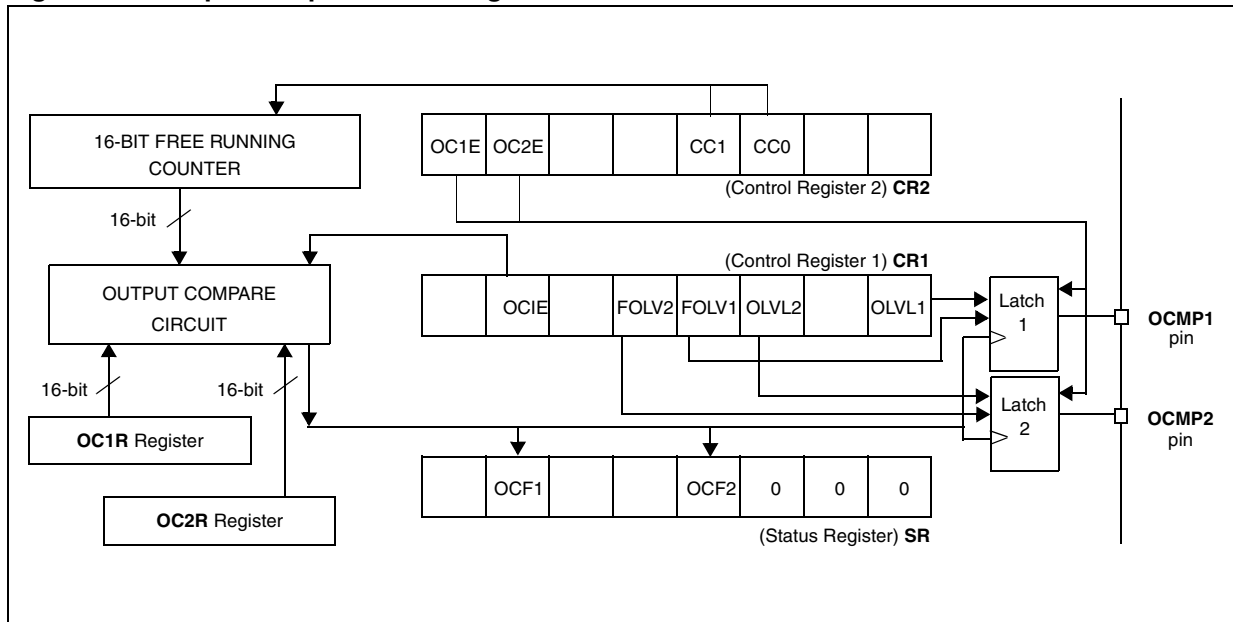

Figure 49. Output compare timing diagram, $f_{\text{TIMER}} = f_{\text{CPU}}/2$

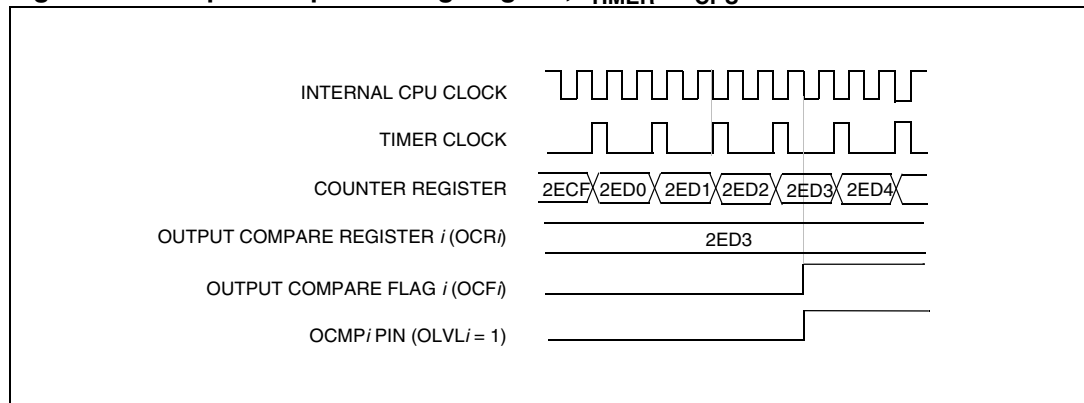
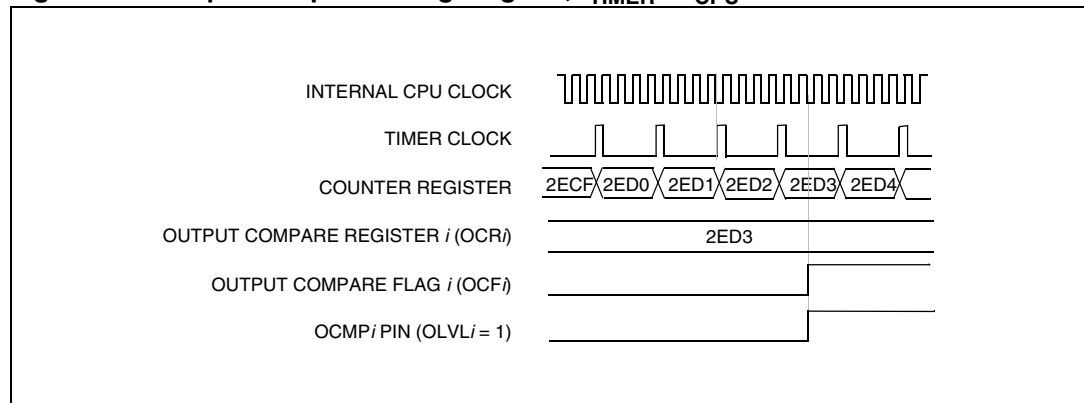

Figure 50. Output compare timing diagram, $f_{\text{TIMER}} = f_{\text{CPU}}/4$



13.3.6 One Pulse mode

One Pulse mode enables the generation of a pulse when an external event occurs. This mode is selected via the OPM bit in the CR2 register.

The one pulse mode uses the Input Capture1 function and the Output Compare1 function.

Procedure

To use one pulse mode:

1. Load the OC1R register with the value corresponding to the length of the pulse (using the appropriate formula below according to the timer clock source used).
2. Select the following in the CR1 register:
 - Using the OLVL1 bit, select the level to be applied to the OCMP1 pin after the pulse.
 - Using the OLVL2 bit, select the level to be applied to the OCMP1 pin during the pulse.
 - Select the edge of the active transition on the ICAP1 pin with the IEDG1 bit (the ICAP1 pin must be configured as floating input).
3. Select the following in the CR2 register:
 - Set the OC1E bit, the OCMP1 pin is then dedicated to the Output Compare 1 function.
 - Set the OPM bit.
 - Select the timer clock CC[1:0] (see [Table 61: Timer clock selection](#)).

Then, on a valid event on the ICAP1 pin, the counter is initialized to FFFCh and OLVL2 bit is loaded on the OCMP1 pin, the ICF1 bit is set and the value FFFDh is loaded in the IC1R register.

Figure 51. One pulse mode cycle flowchart

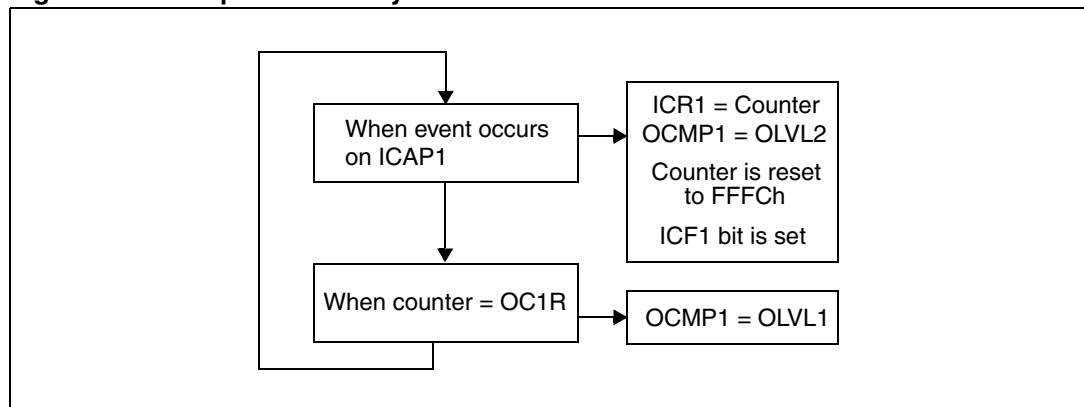

Because the ICF1 bit is set when an active edge occurs, an interrupt can be generated if the ICIE bit is set.

Clearing the input capture interrupt request (that is, clearing the ICF i bit) is done in two steps:

1. Reading the SR register while the ICF i bit is set
2. An access (read or write) to the IC i LR register

The OC1R register value required for a specific timing application can be calculated using the following formula:

$$OC1R \text{ value} = \frac{t * f_{CPU} - 5}{PRESC}$$

Where:

t = Pulse period (in seconds)

f_{CPU} = CPU clock frequency (in hertz)

PRESC = Timer prescaler factor (2, 4 or 8 depending on the CC[1:0] bits; see [Table 61: Timer clock selection](#))

If the timer clock is an external clock the formula is:

$$OC1R = t * f_{EXT} - 5$$

Where:

t = Pulse period (in seconds)

f_{EXT} = External clock frequency (in hertz)

When the value of the counter is equal to the value of the contents of the OC1R register, the OLVL1 bit is output on the OCMP1 pin (see [Figure 52](#)).

- Note:*
- 1 The OCF1 bit cannot be set by hardware in one pulse mode but the OCF2 bit can generate an Output Compare interrupt.
 - 2 When the Pulse Width Modulation (PWM) and One Pulse Mode (OPM) bits are both set, the PWM mode is the only active one.
 - 3 If OLVL1 = OLVL2 a continuous signal will be seen on the OCMP1 pin.
 - 4 The ICAP1 pin cannot be used to perform input capture. The ICAP2 pin can be used to perform input capture (ICF2 can be set and IC2R can be loaded) but the user must take care that the counter is reset each time a valid edge occurs on the ICAP1 pin and ICF1 can also generate interrupt if ICIE is set.
 - 5 When one pulse mode is used OC1R is dedicated to this mode. Nevertheless OC2R and OCF2 can be used to indicate a period of time has been elapsed but cannot generate an output waveform because the level OLVL2 is dedicated to the one pulse mode.

Figure 52. One pulse mode timing example

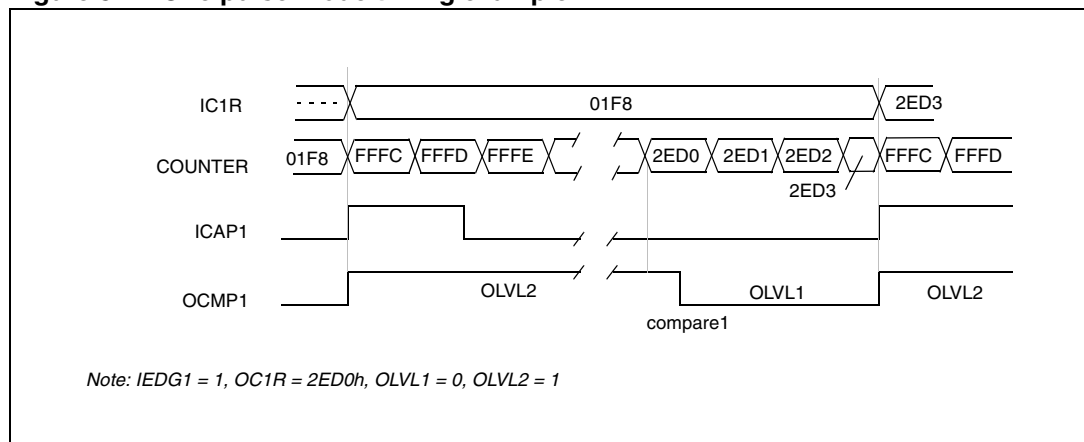
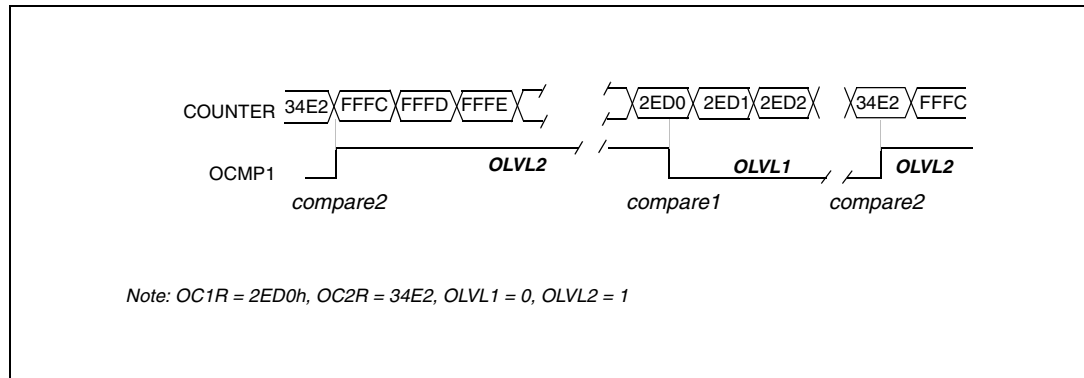

Figure 53. Pulse width modulation mode timing example with 2 output compare functions



Note: On timers with only one Output Compare register, a fixed frequency PWM signal can be generated using the output compare and the counter overflow to define the pulse length.

13.3.7 Pulse width modulation mode

Pulse Width Modulation (PWM) mode enables the generation of a signal with a frequency and pulse length determined by the value of the OC1R and OC2R registers.

Pulse Width Modulation mode uses the complete Output Compare 1 function plus the OC2R register, and so this functionality cannot be used when PWM mode is activated.

In PWM mode, double buffering is implemented on the output compare registers. Any new values written in the OC1R and OC2R registers are taken into account only at the end of the PWM period (OC2) to avoid spikes on the PWM output pin (OCMP1).

Procedure

To use pulse width modulation mode:

1. Load the OC2R register with the value corresponding to the period of the signal using the appropriate formula below according to the timer clock source used.
2. Load the OC1R register with the value corresponding to the period of the pulse if OLVL1 = 0 and OLVL2 = 1 using the appropriate formula below according to the timer clock source used.
3. Select the following in the CR1 register:
 - Using the OLVL1 bit, select the level to be applied to the OCMP1 pin after a successful comparison with the OC1R register.
 - Using the OLVL2 bit, select the level to be applied to the OCMP1 pin after a successful comparison with the OC2R register.
4. Select the following in the CR2 register:
 - Set OC1E bit: the OCMP1 pin is then dedicated to the output compare 1 function.
 - Set the PWM bit.
 - Select the timer clock (CC[1:0]) (see [Table 61: Timer clock selection](#)).

Figure 54. Pulse width modulation cycle flowchart

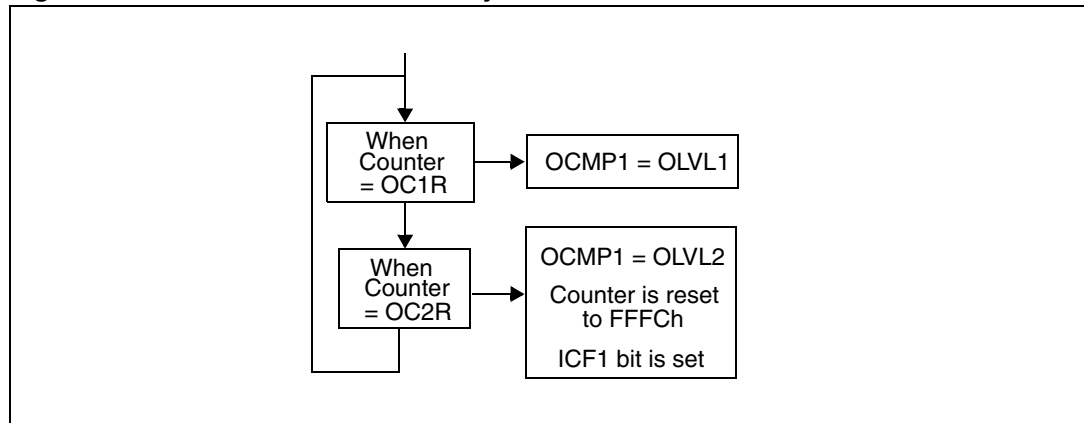

If OLVL1 = 1 and OLVL2 = 0 the length of the positive pulse is the difference between the OC2R and OC1R registers.

If OLVL1 = OLVL2 a continuous signal will be seen on the OCMP1 pin.

The OC*R* register value required for a specific timing application can be calculated using the following formula:

$$OCiR \text{ value} = \frac{t * f_{CPU} - 5}{PRESC}$$

Where:

t = Signal or pulse period (in seconds)

f_{CPU} = CPU clock frequency (in hertz)

PRESC = Timer prescaler factor (2, 4 or 8 depending on CC[1:0] bits; see [Table 61: Timer clock selection](#))

If the timer clock is an external clock the formula is:

$$OCiR = t * f_{EXT} - 5$$

Where:

t = Signal or pulse period (in seconds)

f_{EXT} = External timer clock frequency (in hertz)

The Output Compare 2 event causes the counter to be initialized to FFFCh (see [Figure 53](#)).

- Note:**
- 1 After a write instruction to the OC*i*HR register, the output compare function is inhibited until the OC*i*LR register is also written.
 - 2 The OCF1 and OCF2 bits cannot be set by hardware in PWM mode therefore the Output Compare interrupt is inhibited.
 - 3 The ICF1 bit is set by hardware when the counter reaches the OC2R value and can produce a timer interrupt if the ICIE bit is set and the I bit is cleared.
 - 4 In PWM mode the ICAP1 pin cannot be used to perform input capture because it is disconnected to the timer. The ICAP2 pin can be used to perform input capture (ICF2 can be set and IC2R can be loaded) but the user must take care that the counter is reset each period and ICF1 can also generate interrupt if ICIE is set.
 - 5 When the Pulse Width Modulation (PWM) and One Pulse Mode (OPM) bits are both set, the PWM mode is the only active one.

13.4 Low power modes

Table 56. Effect of low power modes on 16-bit timer

Mode	Effect
Wait	No effect on 16-bit timer. Timer interrupts cause the device to exit from Wait mode.
Halt	16-bit timer registers are frozen. In Halt mode, the counter stops counting until Halt mode is exited. Counting resumes from the previous count when the MCU is woken up by an interrupt with “exit from Halt mode” capability or from the counter reset value when the MCU is woken up by a RESET. If an input capture event occurs on the ICAP <i>i</i> pin, the input capture detection circuitry is armed. Consequently, when the MCU is woken up by an interrupt with “exit from Halt mode” capability, the ICF <i>i</i> bit is set, and the counter value present when exiting from Halt mode is captured into the IC/R register.

13.5 Interrupts

Table 57. 16-bit timer interrupt control/wake-up capability

Interrupt event	Event flag	Enable control bit	Exit from Wait	Exit from Halt
Input Capture 1 event/Counter reset in PWM mode	ICF1	ICIE	Yes	No
Input Capture 2 event	ICF2			
Output Compare 1 event (not available in PWM mode)	OCF1	OCIE		
Output Compare 2 event (not available in PWM mode)	OCF2			
Timer Overflow event	TOF	TOIE		

Note: The 16-bit timer interrupt events are connected to the same interrupt vector (see [Chapter 7: Interrupts on page 49](#)). These events generate an interrupt if the corresponding Enable Control Bit is set and the interrupt mask in the CC register is reset (RIM instruction).

13.6 Summary of timer modes

Table 58. Timer modes

Modes	Timer resources			
	Input Capture 1	Input Capture 2	Output Compare 1	Output Compare 2
Input Capture (1 and/or 2)	Yes	Yes	Yes	Yes
Output Compare (1 and/or 2)				

Table 58. Timer modes

Modes	Timer resources			
	Input Capture 1	Input Capture 2	Output Compare 1	Output Compare 2
One Pulse mode	No	Not recommended ⁽¹⁾	No	Partially ⁽²⁾
PWM mode		Not recommended ⁽³⁾		No

1. See [Note 4](#) in [Section 13.3.6 One Pulse mode](#)
2. See [Note 5](#) in [Section 13.3.6 One Pulse mode](#)
3. See [Note 4](#) in [Section 13.3.7 Pulse width modulation mode](#)

13.7 16-bit timer registers

Each timer is associated with 3 control and status registers, and with 6 pairs of data registers (16-bit values) relating to the 2 input captures, the 2 output compares, the counter and the alternate counter.

13.7.1 Control register 1 (CR1)

CR1	Reset value: 0000 0000 (00h)						
7	6	5	4	3	2	1	0
ICIE	OCIE	TOIE	FOLV2	FOLV1	OLVL2	IEDG1	OLVL1
RW	RW	RW	RW	RW	RW	RW	RW

Table 59. CR1 register description

Bit	Name	Function
7	ICIE	<i>Input Capture Interrupt Enable</i> 0: Interrupt is inhibited 1: A timer interrupt is generated whenever the ICF1 or ICF2 bit of the SR register is set.
6	OCIE	<i>Output Compare Interrupt Enable</i> 0: Interrupt is inhibited 1: A timer interrupt is generated whenever the OCF1 or OCF2 bit of the SR register is set.
5	TOIE	<i>Timer Overflow Interrupt Enable</i> 0: Interrupt is inhibited 1: A timer interrupt is enabled whenever the TOF bit of the SR register is set.
4	FOLV2	<i>Forced Output Compare 2</i> This bit is set and cleared by software. 0: No effect on the OCMP2 pin 1: Forces the OLVL2 bit to be copied to the OCMP2 pin, if the OC2E bit is set and even if there is no successful comparison

Table 59. CR1 register description (continued)

Bit	Name	Function
3	FOLV1	<i>Forced Output Compare 1</i> This bit is set and cleared by software. 0: No effect on the OCMP1 pin 1: Forces OLV1 to be copied to the OCMP1 pin, if the OC1E bit is set and even if there is no successful comparison
2	OLVL2	<i>Output Level 2</i> This bit is copied to the OCMP2 pin whenever a successful comparison occurs with the OC2R register and OCxE is set in the CR2 register. This value is copied to the OCMP1 pin in One Pulse Mode and Pulse Width Modulation mode.
1	IEDG1	<i>Input Edge 1</i> This bit determines which type of level transition on the ICAP1 pin will trigger the capture. 0: A falling edge triggers the capture. 1: A rising edge triggers the capture.
0	OLVL1	<i>Output Level 1</i> The OLV1 bit is copied to the OCMP1 pin whenever a successful comparison occurs with the OC1R register and the OC1E bit is set in the CR2 register.

13.7.2 Control register 2 (CR2)

CR2							Reset value: 0000 0000 (00h)
7	6	5	4	3	2	1	0
OC1E	OC2E	OPM	PWM	CC[1:0]		IEDG2	EXEDG
RW	RW	RW	RW	RW		RW	RW

Table 60. CR2 register description

Bit	Name	Function
7	OC1E	<i>Output Compare 1 Pin Enable</i> This bit is used only to output the signal from the timer on the OCMP1 pin (OLV1 in Output Compare mode, both OLV1 and OLV2 in PWM and one-pulse mode). Whatever the value of the OC1E bit, the Output Compare 1 function of the timer remains active. 0: OCMP1 pin alternate function disabled (I/O pin free for general-purpose I/O) 1: OCMP1 pin alternate function enabled
6	OC2E	<i>Output Compare 2 Pin Enable</i> This bit is used only to output the signal from the timer on the OCMP2 pin (OLV2 in Output Compare mode). Whatever the value of the OC2E bit, the Output Compare 2 function of the timer remains active. 0: OCMP2 pin alternate function disabled (I/O pin free for general-purpose I/O) 1: OCMP2 pin alternate function enabled

Table 60. CR2 register description (continued)

Bit	Name	Function
5	OPM	<i>One Pulse Mode</i> 0: One Pulse Mode is not active. 1: One Pulse Mode is active, the ICAP1 pin can be used to trigger one pulse on the OCMP1 pin; the active transition is given by the IEDG1 bit. The length of the generated pulse depends on the contents of the OC1R register.
4	PWM	<i>Pulse Width Modulation</i> 0: PWM mode is not active. 1: PWM mode is active, the OCMP1 pin outputs a programmable cyclic signal; the length of the pulse depends on the value of OC1R register; the period depends on the value of OC2R register.
3:2	CC[1:0]	<i>Clock Control</i> The timer clock mode depends on these bits (see Table 61).
1	IEDG2	<i>Input Edge 2</i> This bit determines which type of level transition on the ICAP2 pin will trigger the capture. 0: A falling edge triggers the capture. 1: A rising edge triggers the capture.
0	EXEDG	<i>External Clock Edge</i> This bit determines which type of level transition on the external clock pin EXTCLK will trigger the counter register. 0: A falling edge triggers the counter register. 1: A rising edge triggers the counter register.

Table 61. Timer clock selection

Timer clock	CC1	CC0
$f_{CPU} / 4$	0	0
$f_{CPU} / 2$	0	1
$f_{CPU} / 8$	1	0
External clock (where available) ⁽¹⁾	1	1

1. If the external clock pin is not available, programming the external clock configuration stops the counter.

13.7.3 Control/status register (CSR)

CSR							Reset value: xxxx x0xx (xxh)
7	6	5	4	3	2	1	0
ICF1	OCF1	TOF	ICF2	OCF2	TIMD	Reserved	
RO	RO	RO	RO	RO	RW	-	

Table 62. CSR register description

Bit	Name	Function
7	ICF1	<i>Input Capture Flag 1</i> 0: No input capture (reset value) 1: An input capture has occurred on the ICAP1 pin or the counter has reached the OC2R value in PWM mode. To clear this bit, first read the SR register, then read or write the low byte of the IC1R (IC1LR) register.
6	OCF1	<i>Output Compare Flag 1</i> 0: No match (reset value) 1: The content of the free running counter has matched the content of the OC1R register. To clear this bit, first read the SR register, then read or write the low byte of the OC1R (OC1LR) register.
5	TOF	<i>Timer Overflow Flag</i> 0: No timer overflow (reset value) 1: The free running counter rolled over from FFFFh to 0000h. To clear this bit, first read the SR register, then read or write the low byte of the CR (CLR) register. <i>Note: Reading or writing the ACLR register does not clear TOF.</i>
4	ICF2	<i>Input Capture Flag 2</i> 0: No input capture (reset value). 1: An input capture has occurred on the ICAP2 pin. To clear this bit, first read the SR register, then read or write the low byte of the IC2R (IC2LR) register.
3	OCF2	<i>Output Compare Flag 2</i> 0: No match (reset value) 1: The content of the free running counter has matched the content of the OC2R register. To clear this bit, first read the SR register, then read or write the low byte of the OC2R (OC2LR) register.
2	TIMD	<i>Timer disable</i> This bit is set and cleared by software. When set, it freezes the timer prescaler and counter and disabled the output functions (OCMP1 and OCMP2 pins) to reduce power consumption. Access to the timer registers is still available, allowing the timer configuration to be changed, or the counter reset, while it is disabled. 0: Timer enabled 1: Timer prescaler, counter and outputs disabled
1:0	-	Reserved, must be kept cleared

13.7.4 Input capture 1 high register (IC1HR)

This is an 8-bit read only register that contains the high part of the counter value (transferred by the input capture 1 event).

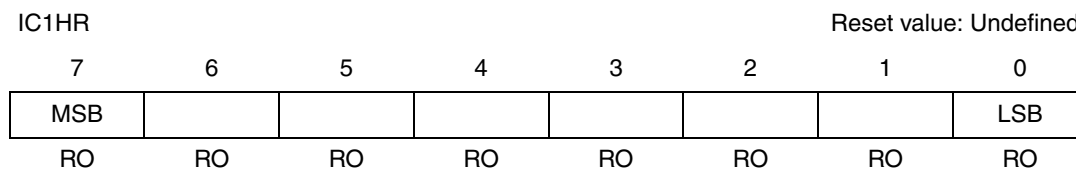

13.7.5 Input capture 1 low register (IC1LR)

This is an 8-bit read only register that contains the low part of the counter value (transferred by the input capture 1 event).

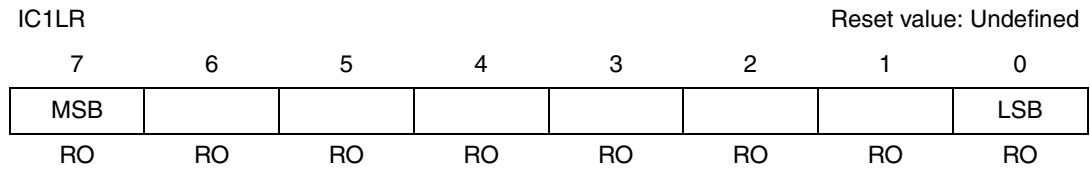

13.7.6 Output compare 1 high register (OC1HR)

This is an 8-bit register that contains the high part of the value to be compared to the CHR register.

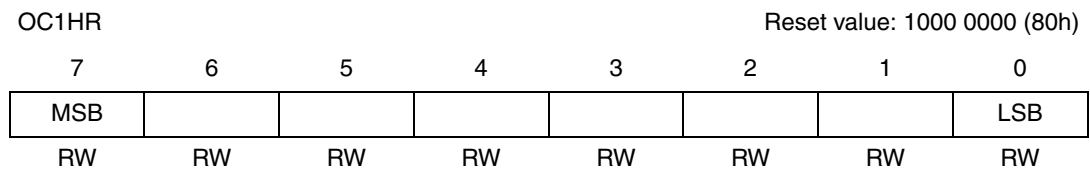

13.7.7 Output compare 1 low register (OC1LR)

This is an 8-bit register that contains the low part of the value to be compared to the CLR register.

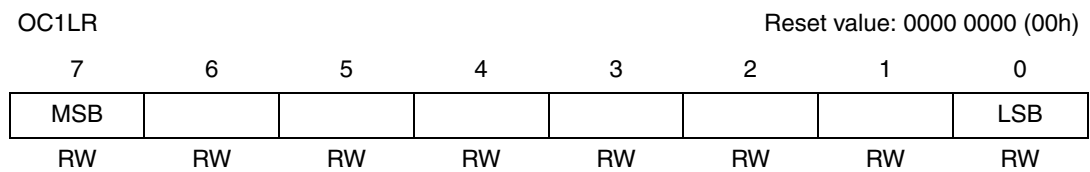

13.7.8 Output compare 2 high register (OC2HR)

This is an 8-bit register that contains the high part of the value to be compared to the CHR register.

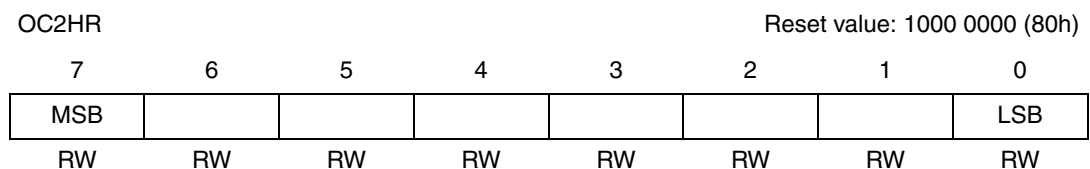

13.7.9 Output compare 2 low register (OC2LR)

This is an 8-bit register that contains the low part of the value to be compared to the CLR register.

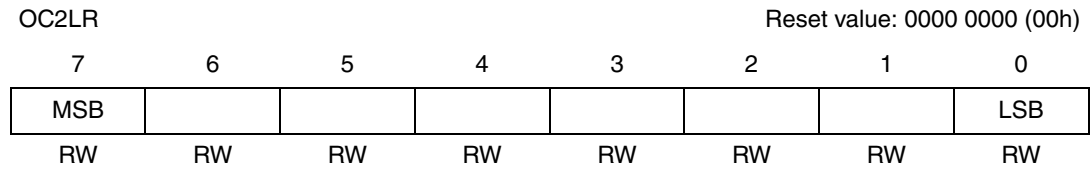

13.7.10 Counter high register (CHR)

This is an 8-bit register that contains the high part of the counter value.

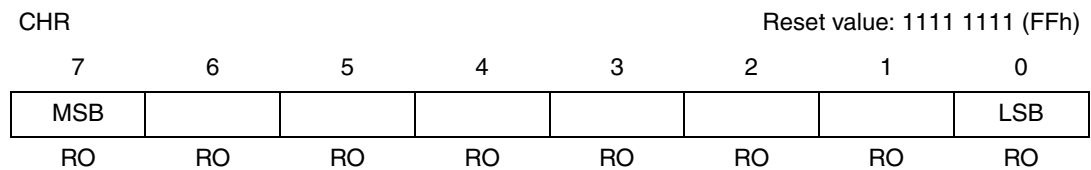

13.7.11 Counter low register (CLR)

This is an 8-bit register that contains the low part of the counter value. A write to this register resets the counter. An access to this register after accessing the CSR register clears the TOF bit.

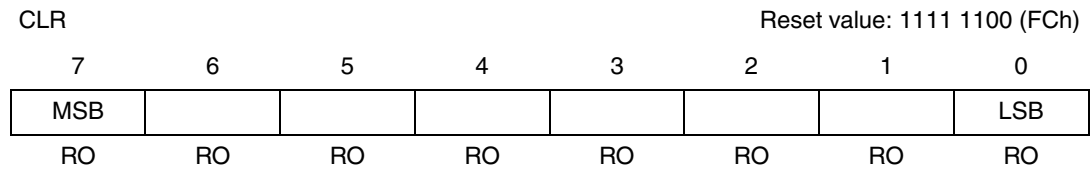

13.7.12 Alternate counter high register (ACHR)

This is an 8-bit register that contains the high part of the counter value.

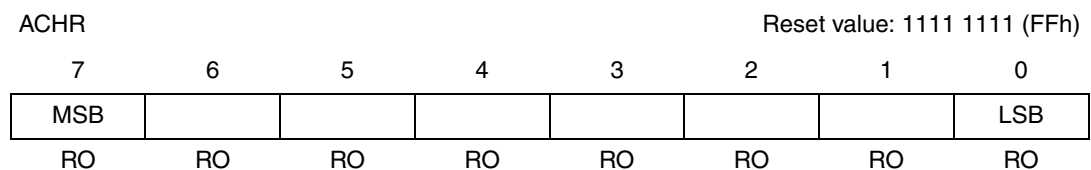

13.7.13 Alternate counter low register (ACLR)

This is an 8-bit register that contains the low part of the counter value. A write to this register resets the counter. An access to this register after an access to CSR register does not clear the TOF bit in the CSR register.

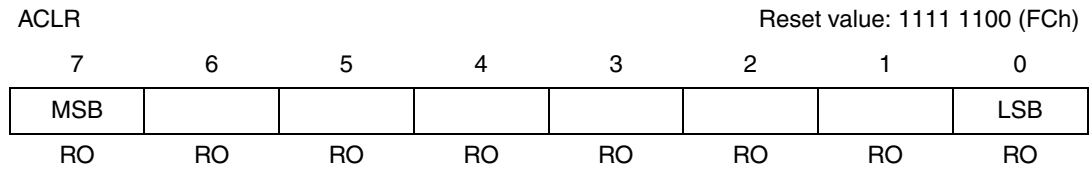

13.7.14 Input capture 2 high register (IC2HR)

This is an 8-bit read only register that contains the high part of the counter value (transferred by the Input Capture 2 event).

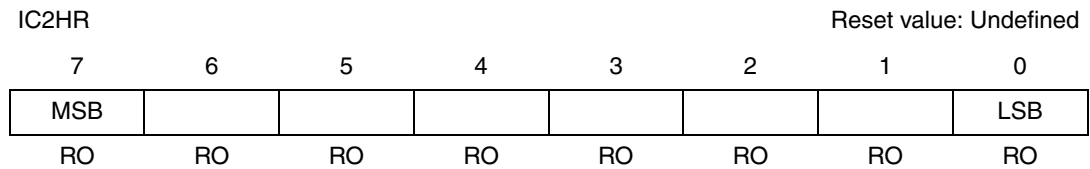

13.7.15 Input capture 2 low register (IC2LR)

This is an 8-bit read only register that contains the low part of the counter value (transferred by the Input Capture 2 event).

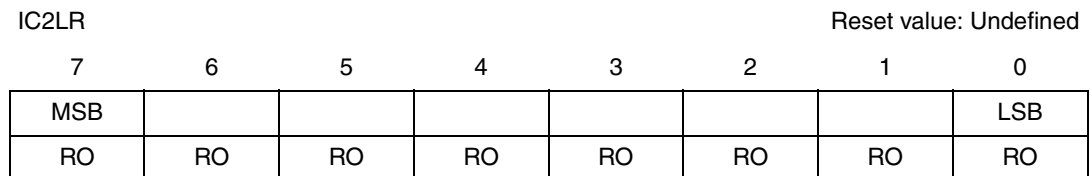

Table 63. 16-bit timer register map and reset values

Address (Hex.)	Register label	7	6	5	4	3	2	1	0
Timer A: 32 Timer B: 42	CR1 Reset value	ICIE 0	OCIE 0	TOIE 0	FOLV2 0	FOLV1 0	OLVL2 0	IEDG1 0	OLVL1 0
Timer A: 31 Timer B: 41	CR2 Reset value	OC1E 0	OC2E 0	OPM 0	PWM 0	CC1 0	CC0 0	IEDG2 0	EXEDG 0
Timer A: 33 Timer B: 43	CSR Reset value	ICF1 x	OCF1 x	TOF x	ICF2 x	OCF2 x	TIMD 0	- x	- x
Timer A: 34 Timer B: 44	IC1HR Reset value	MSB x	x	x	x	x	x	x	LSB x
Timer A: 35 Timer B: 45	IC1LR Reset value	MSB x	x	x	x	x	x	x	LSB x
Timer A: 36 Timer B: 46	OC1HR Reset value	MSB 1	0	0	0	0	0	0	LSB 0
Timer A: 37 Timer B: 47	OC1LR Reset value	MSB 0	0	0	0	0	0	0	LSB 0
Timer A: 3E Timer B: 4E	OC2HR Reset value	MSB 1	0	0	0	0	0	0	LSB 0
Timer A: 3F Timer B: 4F	OC2LR Reset value	MSB 0	0	0	0	0	0	0	LSB 0
Timer A: 38 Timer B: 48	CHR Reset value	MSB 1	1	1	1	1	1	1	LSB 1
Timer A: 39 Timer B: 49	CLR Reset value	MSB 1	1	1	1	1	1	0	LSB 0
Timer A: 3A Timer B: 4A	ACHR Reset value	MSB 1	1	1	1	1	1	1	LSB 1
Timer A: 3B Timer B: 4B	ACLR Reset value	MSB 1	1	1	1	1	1	0	LSB 0
Timer A: 3C Timer B: 4C	IC2HR Reset value	MSB x	x	x	x	x	x	x	LSB x
Timer A: 3D Timer B: 4D	IC2LR Reset value	MSB x	x	x	x	x	x	x	LSB x

Related documentation

SCI software communications using 16-bit timer (AN 973)

Real-time Clock with ST7 Timer Output Compare (AN 974)

Driving a buzzer through the ST7 Timer PWM function (AN 976)

Using ST7 PWM signal to generate analog input (sinusoid) (AN1041)

UART emulation software (AN1046)

PWM duty cycle switch implementing true 0 or 100 per cent duty cycle (AN1078)

Starting a PWM signal directly at high level using the ST7 16-bit timer (AN1504)

14 Serial peripheral interface (SPI)

14.1 Introduction

The Serial Peripheral Interface (SPI) allows full-duplex, synchronous, serial communication with external devices. An SPI system may consist of a master and one or more slaves however the SPI interface cannot be a master in a multimaster system.

14.2 Main features

- Full duplex synchronous transfers (on 3 lines)
- Simplex synchronous transfers (on 2 lines)
- Master or slave operation
- 6 master mode frequencies ($f_{\text{CPU}}/4$ max.)
- $f_{\text{CPU}}/2$ max. slave mode frequency (see note)
- $\overline{\text{SS}}$ Management by software or hardware
- Programmable clock polarity and phase
- End of transfer interrupt flag
- Write collision, Master Mode Fault and Overrun flags

Note: In slave mode, continuous transmission is not possible at maximum frequency due to the software overhead for clearing status flags and to initiate the next transmission sequence.

14.3 General description

Figure 55 shows the serial peripheral interface (SPI) block diagram. There are three registers:

- SPI Control Register (SPICR)
- SPI Control/Status Register (SPICSR)
- SPI Data Register (SPIDR)

The SPI is connected to external devices through four pins:

- MISO (Master In / Slave Out data)
- MOSI (Master Out / Slave In data)
- SCK (Serial Clock out by SPI masters and input by SPI slaves)
- $\overline{\text{SS}}$ (Slave select): This input signal acts as a 'chip select' to let the SPI master communicate with slaves individually and to avoid contention on the data lines. Slave $\overline{\text{SS}}$ inputs can be driven by standard I/O ports on the master MCU.

Figure 55. Serial peripheral interface block diagram

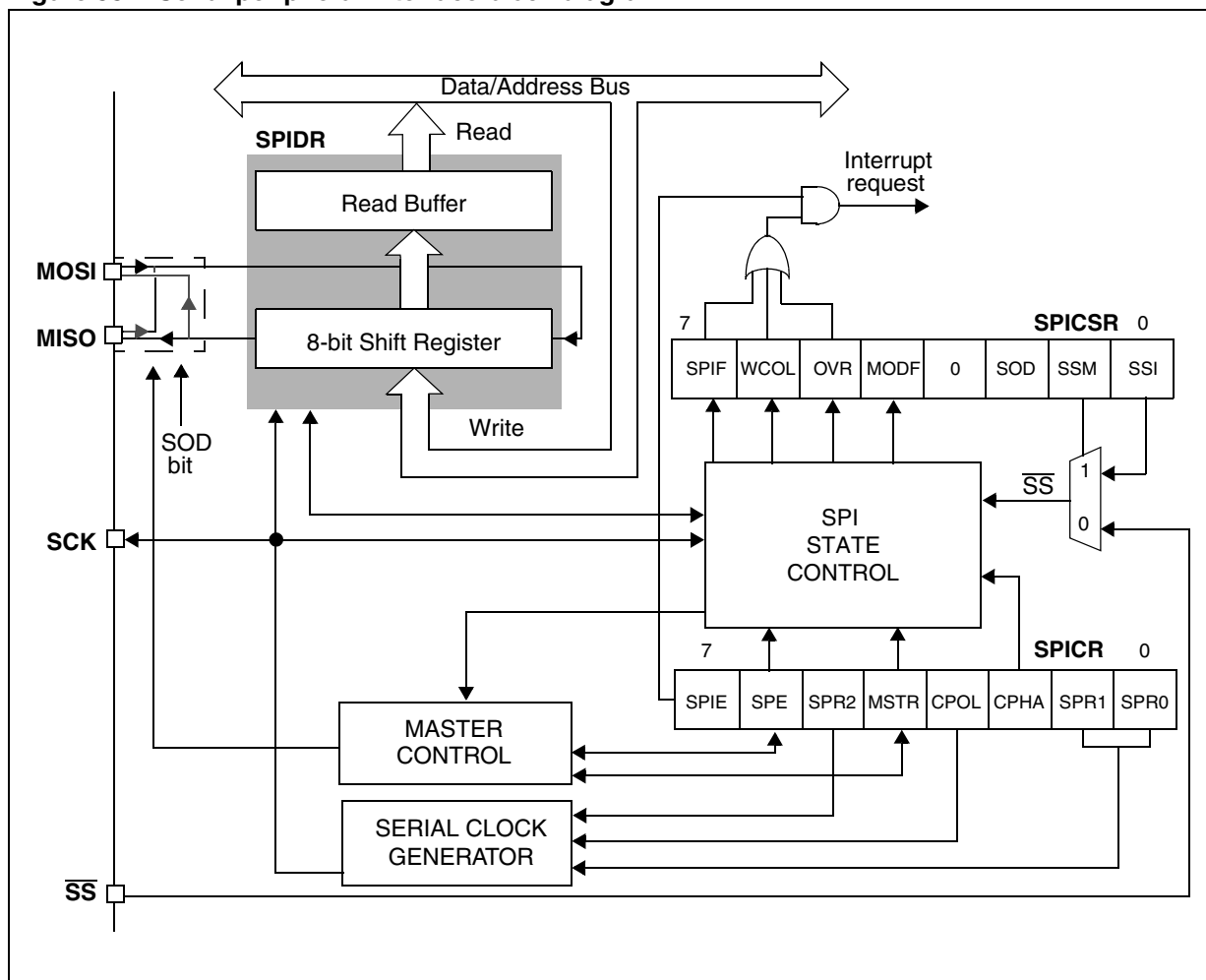

14.3.1 Functional description

A basic example of interconnections between a single master and a single slave is illustrated in [Figure 56](#).

The **MOSI** pins are connected together and the **MISO** pins are connected together. In this way data is transferred serially between master and slave (most significant bit first).

The communication is always initiated by the master. When the master device transmits data to a slave device via **MOSI** pin, the slave device responds by sending data to the master device via the **MISO** pin. This implies full duplex communication with both data out and data in synchronized with the same clock signal (which is provided by the master device via the **SCK** pin).

To use a single data line, the **MISO** and **MOSI** pins must be connected at each node (in this case only simplex communication is possible).

Four possible data/clock timing relationships may be chosen (see [Figure 59](#)) but master and slave must be programmed with the same timing mode.

Figure 56. Single master/single slave application

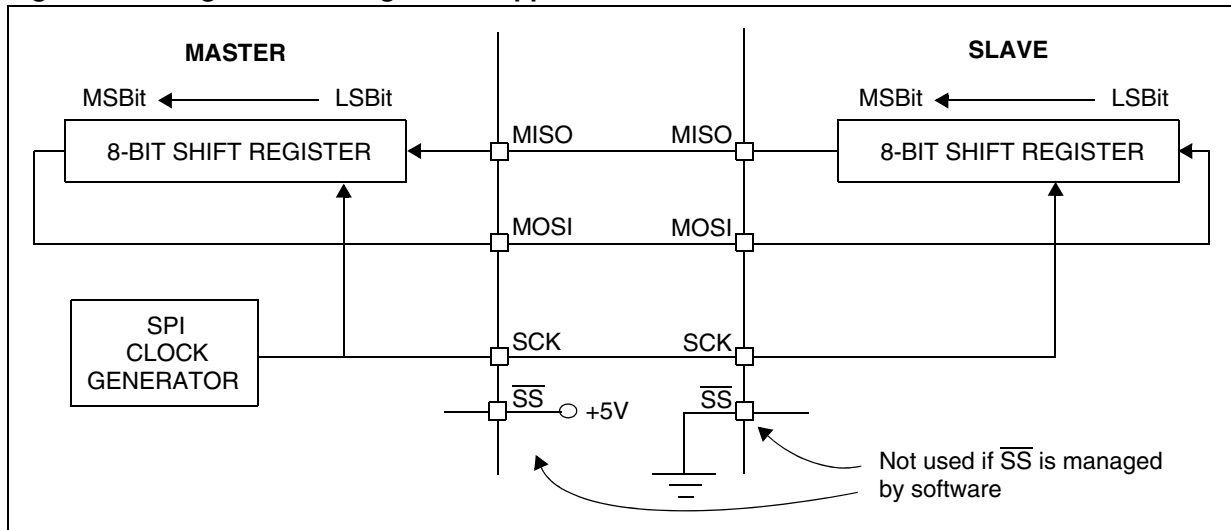

14.3.2 Slave select management

As an alternative to using the \overline{SS} pin to control the Slave Select signal, the application can choose to manage the Slave Select signal by software. This is configured by the SSM bit in the SPICSR register (see [Figure 58](#))

In software management, the external \overline{SS} pin is free for other application uses and the internal \overline{SS} signal level is driven by writing to the SSI bit in the SPICSR register.

In Master mode

- \overline{SS} internal must be held high continuously

In Slave mode

There are two cases depending on the data/clock timing relationship (see [Figure 57](#)):

If CPHA = 1 (data latched on 2nd clock edge):

- \overline{SS} internal must be held low during the entire transmission. This implies that in single slave applications the \overline{SS} pin either can be tied to V_{SS} , or made free for standard I/O by managing the \overline{SS} function by software (SSM = 1 and SSI = 0 in the in the SPICSR register)

If CPHA = 0 (data latched on 1st clock edge):

- \overline{SS} internal must be held low during byte transmission and pulled high between each byte to allow the slave to write to the shift register. If \overline{SS} is not pulled high, a Write Collision error will occur when the slave writes to the shift register (see [Write collision error \(WCOL\) on page 128](#)).

Figure 57. Generic \overline{SS} timing diagram

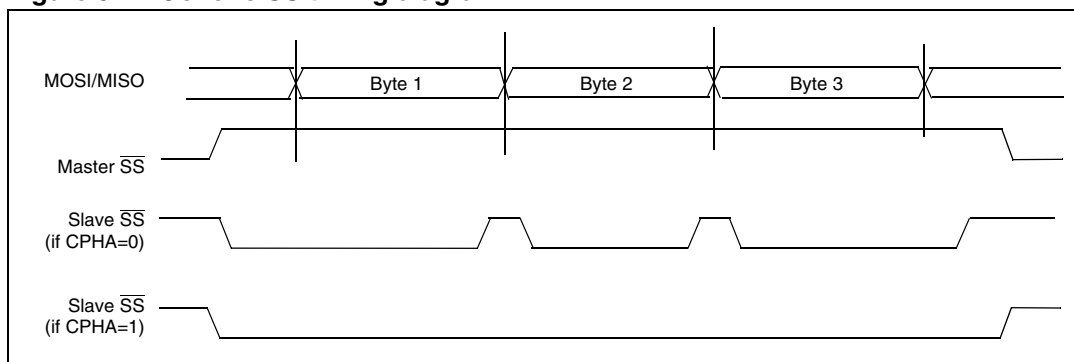
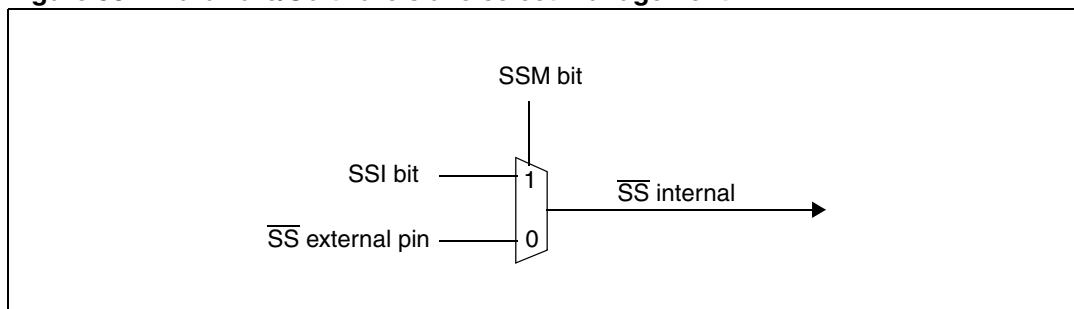

Figure 58. Hardware/Software slave select management



14.3.3 Master mode operation

In master mode, the serial clock is output on the SCK pin. The clock frequency, polarity and phase are configured by software (refer to the description of the SPICSR register).

Note: The idle state of SCK must correspond to the polarity selected in the SPICSR register (by pulling up SCK if CPOL = 1 or pulling down SCK if CPOL = 0).

How to operate the SPI in master mode

To operate the SPI in master mode, perform the following steps in order:

1. Write to the SPICR register:
 - a) Select the clock frequency by configuring the SPR[2:0] bits.
 - b) Select the clock polarity and clock phase by configuring the CPOL and CPHA bits. *Figure 59* shows the four possible configurations.

Note: The slave must have the same CPOL and CPHA settings as the master.

2. Write to the SPICSR register:

Either set the SSM bit and set the SSI bit or clear the SSM bit and tie the \overline{SS} pin high for the complete byte transmit sequence.
3. Write to the SPICR register:

Set the MSTR and SPE bits

Note: MSTR and SPE bits remain set only if \overline{SS} is high).

IMPORTANT: If the SPICSR register is not written first, the SPICR register setting (MSTR bit) may not be taken into account.

The transmit sequence begins when software writes a byte in the SPIDR register.

14.3.4 Master mode transmit sequence

When software writes to the SPIDR register, the data byte is loaded into the 8-bit shift register and then shifted out serially to the MOSI pin most significant bit first.

When data transfer is complete:

- The SPIF bit is set by hardware
- An interrupt request is generated if the SPIE bit is set and the interrupt mask in the CCR register is cleared.

Clearing the SPIF bit is performed by the following software sequence:

1. An access to the SPICSR register while the SPIF bit is set
2. A read to the SPIDR register.

Note: While the SPIF bit is set, all writes to the SPIDR register are inhibited until the SPICSR register is read.

14.3.5 Slave mode operation

In slave mode, the serial clock is received on the SCK pin from the master device.

To operate the SPI in slave mode:

1. Write to the SPICSR register to perform the following actions:
 - a) Select the clock polarity and clock phase by configuring the CPOL and CPHA bits (see [Figure 59](#)).

Note: The slave must have the same CPOL and CPHA settings as the master.

- b) Manage the \overline{SS} pin as described in [Slave select management on page 123](#) and [Figure 57](#). If CPHA = 1, \overline{SS} must be held low continuously. If CPHA = 0, \overline{SS} must be held low during byte transmission and pulled up between each byte to let the slave write in the shift register.
2. Write to the SPICR register to clear the MSTR bit and set the SPE bit to enable the SPI I/O functions.

14.3.6 Slave mode transmit sequence

When software writes to the SPIDR register, the data byte is loaded into the 8-bit shift register and then shifted out serially to the MISO pin most significant bit first.

The transmit sequence begins when the slave device receives the clock signal and the most significant bit of the data on its MOSI pin.

When data transfer is complete:

- The SPIF bit is set by hardware.
- An interrupt request is generated if SPIE bit is set and interrupt mask in the CCR register is cleared.

Clearing the SPIF bit is performed by the following software sequence:

1. An access to the SPICSR register while the SPIF bit is set
2. A write or a read to the SPIDR register

Note: While the SPIF bit is set, all writes to the SPIDR register are inhibited until the SPICSR register is read.

The SPIF bit can be cleared during a second transmission; however, it must be cleared before the second SPIF bit in order to prevent an Overrun condition (see [Overrun condition \(OVR\) on page 128](#)).

14.4 Clock phase and clock polarity

Four possible timing relationships may be chosen by software, using the CPOL and CPHA bits (see [Figure 59](#)).

Note: The idle state of SCK must correspond to the polarity selected in the SPICSR register (by pulling up SCK if CPOL = 1 or pulling down SCK if CPOL = 0).

The combination of the CPOL clock polarity and CPHA (clock phase) bits selects the data capture clock edge

[Figure 59](#) shows an SPI transfer with the four combinations of the CPHA and CPOL bits. The diagram may be interpreted as a master or slave timing diagram where the SCK pin, the MISO pin, the MOSI pin are directly connected between the master and the slave device.

Note: If CPOL is changed at the communication byte boundaries, the SPI must be disabled by resetting the SPE bit.

Figure 59. Data clock timing diagram

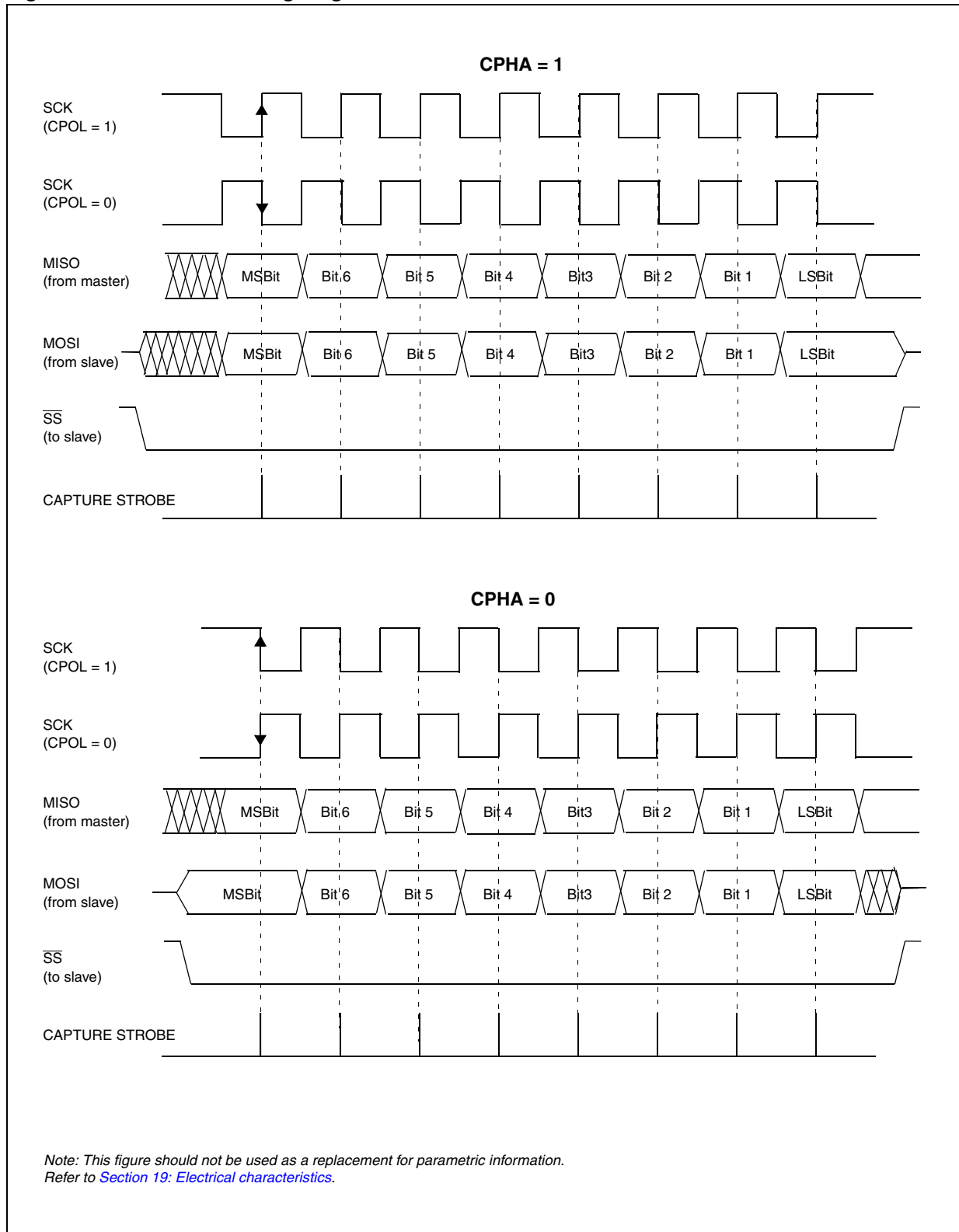

14.5 Error flags

14.5.1 Master mode fault (MODF)

Master mode fault occurs when the master device has its \overline{SS} pin pulled low.

When a Master mode fault occurs:

- The MODF bit is set and an SPI interrupt request is generated if the SPIE bit is set.
- The SPE bit is reset. This blocks all output from the device and disables the SPI peripheral.
- The MSTR bit is reset, thus forcing the device into slave mode.

Clearing the MODF bit is done through a software sequence:

1. A read access to the SPICSR register while the MODF bit is set.
2. A write to the SPICR register.

Note: To avoid any conflicts in an application with multiple slaves, the \overline{SS} pin must be pulled high during the MODF bit clearing sequence. The SPE and MSTR bits may be restored to their original state during or after this clearing sequence.

Hardware does not allow the user to set the SPE and MSTR bits while the MODF bit is set except in the MODF bit clearing sequence.

14.5.2 Overrun condition (OVR)

An overrun condition occurs, when the master device has sent a data byte and the slave device has not cleared the SPIF bit issued from the previously transmitted byte.

When an Overrun occurs:

- The OVR bit is set and an interrupt request is generated if the SPIE bit is set.

In this case, the receiver buffer contains the byte sent after the SPIF bit was last cleared. A read to the SPIDR register returns this byte. All other bytes are lost.

The OVR bit is cleared by reading the SPICSR register.

14.5.3 Write collision error (WCOL)

A write collision occurs when the software tries to write to the SPIDR register while a data transfer is taking place with an external device. When this happens, the transfer continues uninterrupted; and the software write will be unsuccessful.

Write collisions can occur both in master and slave mode. See also [Slave select management on page 123](#).

Note: A “read collision” will never occur since the received data byte is placed in a buffer in which access is always synchronous with the MCU operation.

The WCOL bit in the SPICSR register is set if a write collision occurs.

No SPI interrupt is generated when the WCOL bit is set (the WCOL bit is a status flag only).

Clearing the WCOL bit is done through a software sequence (see [Figure 60](#)).

Figure 60. Clearing the WCOL bit (Write Collision Flag) software sequence

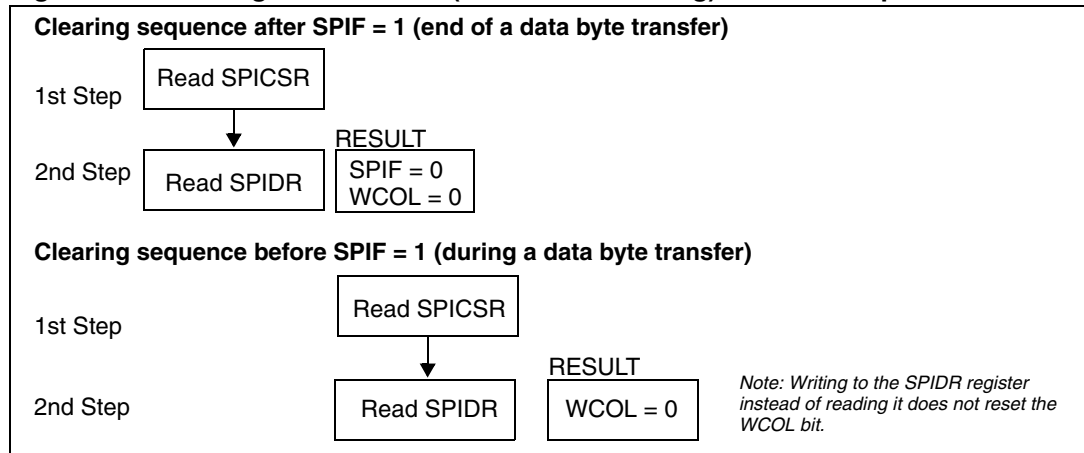

14.5.4 Single master systems

A typical single master system may be configured, using an MCU as the master and four MCUs as slaves (see [Figure 61](#)).

The master device selects the individual slave devices by using four pins of a parallel port to control the four \overline{SS} pins of the slave devices.

The \overline{SS} pins are pulled high during reset since the master device ports will be forced to be inputs at that time, thus disabling the slave devices.

Note: To prevent a bus conflict on the MISO line the master allows only one active slave device during a transmission.

For more security, the slave device may respond to the master with the received data byte. Then the master will receive the previous byte back from the slave device if all MISO and MOSI pins are connected and the slave has not written to its SPIDR register.

Other transmission security methods can use ports for handshake lines or data bytes with command fields.

Figure 61. Single master / multiple slave configuration

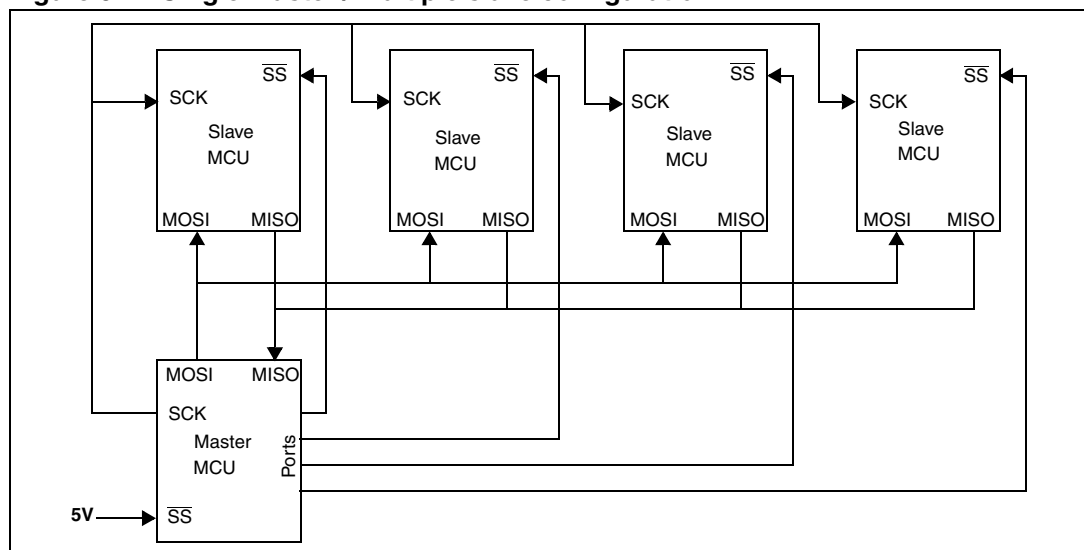

14.6 Low power modes

Table 64. Effect of low power modes on SPI

Mode	Effect
Wait	No effect on SPI. SPI interrupt events cause the device to exit from Wait mode.
Halt	SPI registers are frozen. In Halt mode, the SPI is inactive. SPI operation resumes when the MCU is woken up by an interrupt with “exit from Halt mode” capability. The data received is subsequently read from the SPIDR register when the software is running (interrupt vector fetching). If several data are received before the wake-up event, then an overrun error is generated. This error can be detected after the fetch of the interrupt routine that woke up the device.

14.6.1 Using the SPI to wake up the MCU from Halt mode

In slave configuration, the SPI is able to wake up the ST7 device from Halt mode through a SPIF interrupt. The data received is subsequently read from the SPIDR register when the software is running (interrupt vector fetch). If multiple data transfers have been performed before software clears the SPIF bit, then the OVR bit is set by hardware.

Note: When waking up from Halt mode, if the SPI remains in Slave mode, it is recommended to perform an extra communications cycle to bring the SPI from Halt mode state to normal state. If the SPI exits from Slave mode, it returns to normal state immediately.

Caution: The SPI can wake up the ST7 from Halt mode only if the Slave Select signal (external \overline{SS} pin or the SSI bit in the SPICSR register) is low when the ST7 enters Halt mode. So if Slave selection is configured as external (see [Slave select management on page 123](#)), make sure the master drives a low level on the \overline{SS} pin when the slave enters Halt mode.

14.7 Interrupts

Table 65. SPI interrupt control/wake-up capability

Interrupt event	Event flag	Enable control bit	Exit from Wait	Exit from Halt
SPI End of Transfer event	SPIF	SPIE	Yes	Yes
Master Mode Fault event	MODF			No
Overrun error	OVR			

Note: The SPI interrupt events are connected to the same interrupt vector (see [Interrupts chapter](#)). They generate an interrupt if the corresponding Enable Control Bit is set and the interrupt mask in the CC register is reset (RIM instruction).

14.8 SPI registers

14.8.1 Control register (SPICR)

SPICR							Reset value: 0000 xxxx (0xh)
7	6	5	4	3	2	1	0
SPIE	SPE	SPR2	MSTR	CPOL	CPHA	SPR[1:0]	
RW	RW	RW	RW	RW	RW	RW	

Table 66. SPICR register description

Bit	Name	Function
7	SPIE	<p><i>Serial Peripheral Interrupt Enable</i></p> <p>This bit is set and cleared by software.</p> <p>0: Interrupt is inhibited</p> <p>1: An SPI interrupt is generated whenever SPIF = 1, MODF = 1 or OVR = 1 in the SPICSR register.</p>
6	SPE	<p><i>Serial Peripheral Output Enable</i></p> <p>This bit is set and cleared by software. It is also cleared by hardware when, in master mode, $\overline{SS} = 0$ (see Master mode fault (MODF) on page 128). The SPE bit is cleared by reset, so the SPI peripheral is not initially connected to the external pins.</p> <p>0: I/O pins free for general purpose I/O</p> <p>1: SPI I/O pin alternate functions enabled</p>
5	SPR2	<p><i>Divider Enable</i></p> <p>This bit is set and cleared by software and is cleared by reset. It is used with the SPR[1:0] bits to set the baud rate. Refer to Table 67.</p> <p>0: Divider by 2 enabled</p> <p>1: Divider by 2 disabled</p> <p><i>Note: This bit has no effect in slave mode.</i></p>
4	MSTR	<p><i>Master Mode</i></p> <p>This bit is set and cleared by software. It is also cleared by hardware when, in master mode, $\overline{SS} = 0$ (see Master mode fault (MODF) on page 128).</p> <p>0: Slave mode</p> <p>1: Master mode. The function of the SCK pin changes from an input to an output and the functions of the MISO and MOSI pins are reversed.</p>
3	CPOL	<p><i>Clock Polarity</i></p> <p>This bit is set and cleared by software. This bit determines the idle state of the serial Clock. The CPOL bit affects both the master and slave modes.</p> <p>0: SCK pin has a low level idle state</p> <p>1: SCK pin has a high level idle state</p> <p><i>Note: If CPOL is changed at the communication byte boundaries, the SPI must be disabled by resetting the SPE bit.</i></p>
2	CPHA	<p><i>Clock Phase</i></p> <p>This bit is set and cleared by software.</p> <p>0: The first clock transition is the first data capture edge.</p> <p>1: The second clock transition is the first capture edge.</p> <p><i>Note: The slave must have the same CPOL and CPHA settings as the master.</i></p>

Table 66. SPICR register description (continued)

Bit	Name	Function
1:0	SPR[1:0]	<p><i>Serial Clock Frequency</i></p> <p>These bits are set and cleared by software. Used with the SPR2 bit, they select the baud rate of the SPI serial clock SCK output by the SPI in master mode.</p> <p><i>Note: These 2 bits have no effect in slave mode.</i></p>

Table 67. SPI master mode SCK frequency

Serial clock	SPR2	SPR1	SPR0
$f_{CPU}/4$	1	0	0
$f_{CPU}/8$	0	0	0
$f_{CPU}/16$	0	0	1
$f_{CPU}/32$	1	1	0
$f_{CPU}/64$	0	1	0
$f_{CPU}/128$	0	1	1

14.8.2 Control/status register (SPICSR)

SPICSR							Reset value: 0000 0000 (00h)	
7	6	5	4	3	2	1	0	
SPIF	WCOL	OVR	MODF	Reserved	SOD	SSM	SSI	
RO	RO	RO	RO	-	RW	RW	RW	

Table 68. SPICSR register description

Bit	Name	Function
7	SPIF	<p><i>Serial Peripheral Data Transfer Flag</i></p> <p>This bit is set by hardware when a transfer has been completed. An interrupt is generated if SPIE = 1 in the SPICR register. It is cleared by a software sequence (an access to the SPICSR register followed by a write or a read to the SPIDR register).</p> <p>0: Data transfer is in progress or the flag has been cleared</p> <p>1: Data transfer between the device and an external device has been completed. While the SPIF bit is set, all writes to the SPIDR register are inhibited until the SPICSR register is read.</p>
6	WCOL	<p><i>Write Collision status</i></p> <p>This bit is set by hardware when a write to the SPIDR register is done during a transmit sequence. It is cleared by a software sequence (see Figure 60).</p> <p>0: No write collision occurred.</p> <p>1: A write collision has been detected.</p>
5	OVR	<p><i>SPI Overrun error</i></p> <p>This bit is set by hardware when the byte currently being received in the shift register is ready to be transferred into the SPIDR register while SPIF = 1 (see Overrun condition (OVR) on page 128). An interrupt is generated if SPIE = 1 in SPICR register. The OVR bit is cleared by software reading the SPICSR register.</p> <p>0: No overrun error</p> <p>1: Overrun error detected</p>

Table 68. SPICSR register description (continued)

Bit	Name	Function
4	MODF	<p><i>Mode Fault flag</i></p> <p>This bit is set by hardware when the \overline{SS} pin is pulled low in master mode (see Master mode fault (MODF) on page 128). An SPI interrupt can be generated if SPIE = 1 in the SPICSR register. This bit is cleared by a software sequence (An access to the SPICR register while MODF = 1 followed by a write to the SPICR register).</p> <p>0: No master mode fault detected 1: A fault in master mode has been detected</p>
3	-	Reserved, must be kept cleared
2	SOD	<p><i>SPI Output Disable</i></p> <p>This bit is set and cleared by software. When set, it disables the alternate function of the SPI output (MOSI in master mode / MISO in slave mode).</p> <p>0: SPI output enabled (if SPE = 1) 1: SPI output disabled</p>
1	SSM	<p><i>\overline{SS} Management</i></p> <p>This bit is set and cleared by software. When set, it disables the alternate function of the SPI \overline{SS} pin and uses the SSI bit value instead. See Slave select management on page 123.</p> <p>0: Hardware management (\overline{SS} managed by external pin) 1: Software management (internal \overline{SS} signal controlled by SSI bit. External \overline{SS} pin free for general-purpose I/O)</p>
0	SSI	<p><i>\overline{SS} Internal Mode</i></p> <p>This bit is set and cleared by software. It acts as a 'chip select' by controlling the level of the \overline{SS} slave select signal when the SSM bit is set.</p> <p>0: Slave selected 1: Slave deselected</p>

14.8.3 Data I/O register (SPIDR)

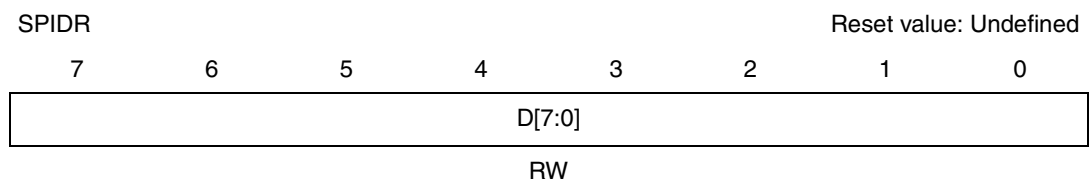

The SPIDR register is used to transmit and receive data on the serial bus. In a master device, a write to this register will initiate transmission/reception of another byte.

Note: During the last clock cycle the SPIF bit is set, a copy of the received data byte in the shift register is moved to a buffer. When the user reads the serial peripheral data I/O register, the buffer is actually being read.

While the SPIF bit is set, all writes to the SPIDR register are inhibited until the SPICSR register is read.

Warning: A write to the SPIDR register places data directly into the shift register for transmission.

A read to the SPIDR register returns the value located in the buffer and not the content of the shift register (see [Figure 55](#)).

Table 69. SPI register map and reset values

Address (Hex.)	Register label	7	6	5	4	3	2	1	0
0021h	SPIDR Reset value	MSB x	x	x	x	x	x	x	LSB x
0022h	SPICR Reset value	SPIE 0	SPE 0	SPR2 0	MSTR 0	CPOL x	CPHA x	SPR1 x	SPR0 x
0023h	SPICSR Reset value	SPIF 0	WCOL 0	OVR 0	MODF 0	0	SOD 0	SSM 0	SSI 0

15 Serial communications interface (SCI)

15.1 Introduction

The Serial Communications Interface (SCI) offers a flexible means of full-duplex data exchange with external equipment requiring an industry standard NRZ asynchronous serial data format. The SCI offers a very wide range of baud rates using two baud rate generator systems.

15.2 Main features

- Full duplex, asynchronous communications
- NRZ standard format (Mark/Space)
- Dual baud rate generator systems
- Independently programmable transmit and receive baud rates up to 500K baud
- Programmable data word length (8 or 9 bits)
- Receive buffer full, Transmit buffer empty and End of Transmission flags
- 2 receiver wake-up modes:
 - Address bit (MSB)
 - Idle line
- Muting function for multiprocessor configurations
- Separate enable bits for Transmitter and Receiver
- 4 error detection flags:
 - Overrun error
 - Noise error
 - Frame error
 - Parity error
- 5 interrupt sources with flags:
 - Transmit data register empty
 - Transmission complete
 - Receive data register full
 - Idle line received
 - Overrun error detected
- Parity control:
 - Transmits parity bit
 - Checks parity of received data byte
- Reduced power consumption mode

15.3 General description

The interface is externally connected to another device by two pins (see [Figure 63](#)):

- TDO: Transmit Data Output. When the transmitter and the receiver are disabled, the output pin returns to its I/O port configuration. When the transmitter and/or the receiver are enabled and nothing is to be transmitted, the TDO pin is at high level.
- RDI: Receive Data Input is the serial data input. Oversampling techniques are used for data recovery by discriminating between valid incoming data and noise.

Through these pins, serial data is transmitted and received as frames comprising:

- An Idle Line prior to transmission or reception
- A start bit
- A data word (8 or 9 bits) least significant bit first
- A Stop bit indicating that the frame is complete

This interface uses two types of baud rate generator:

- A conventional type for commonly-used baud rates
- An extended type with a prescaler offering a very wide range of baud rates even with non-standard oscillator frequencies

Figure 62. SCI block diagram

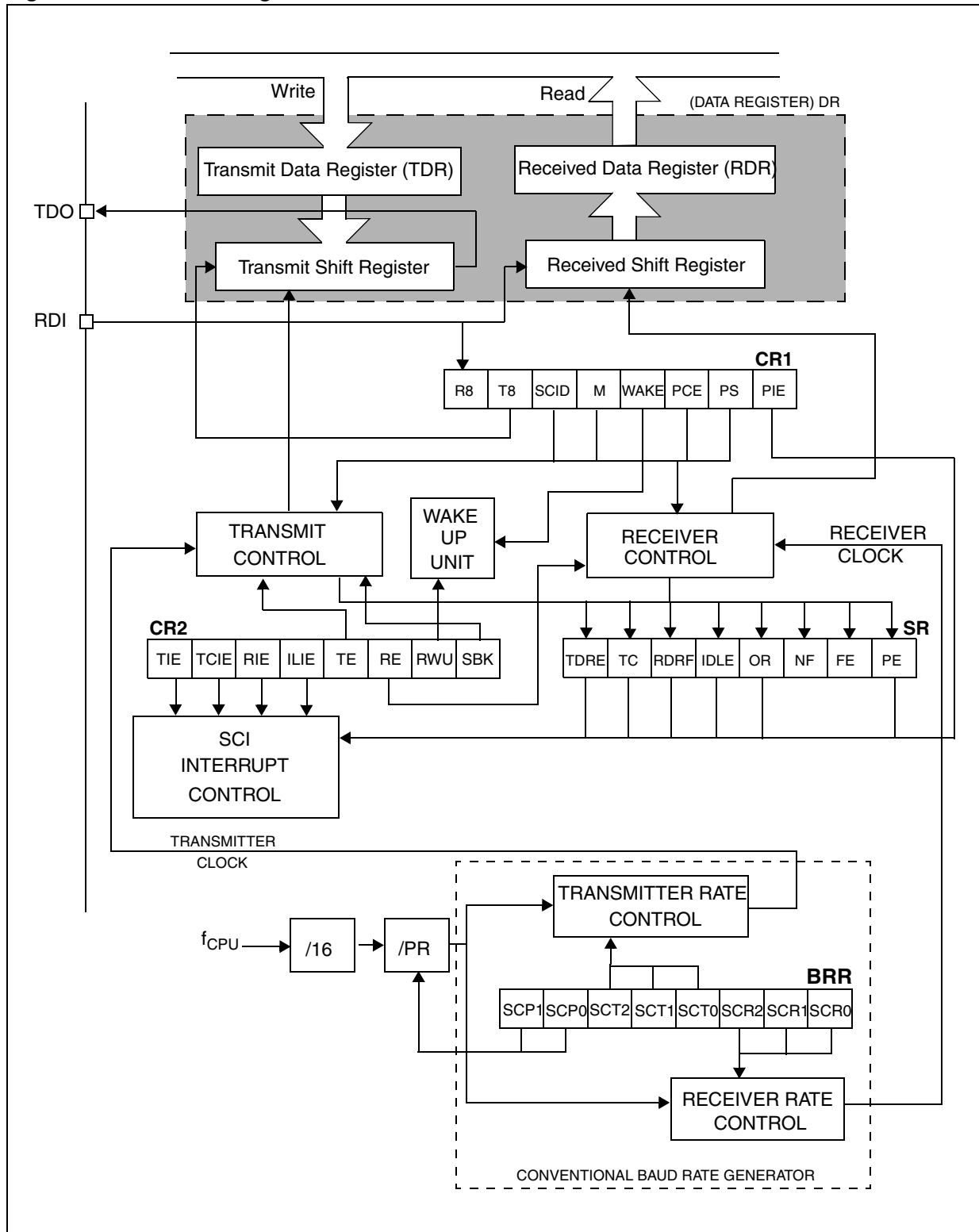

15.4 Functional description

The block diagram of the Serial Control Interface, is shown in [Figure 62](#). It contains six dedicated registers:

- 2 control registers (SCICR1 and SCICR2)
- a status register (SCISR)
- a baud rate register (SCIBRR)
- an extended prescaler receiver register (SCIERP)
- an extended prescaler transmitter register (SCIETPR)

Refer to the register descriptions in [Section 15.7](#) for the definitions of each bit.

15.4.1 Serial data format

Word length may be selected as being either 8 or 9 bits by programming the M bit in the SCICR1 register (see [Figure 62](#)).

The TDO pin is in low state during the start bit.

The TDO pin is in high state during the stop bit.

An Idle character is interpreted as an entire frame of '1's followed by the start bit of the next frame which contains data.

A Break character is interpreted on receiving '0's for some multiple of the frame period. At the end of the last break frame the transmitter inserts an extra '1' bit to acknowledge the start bit.

Transmission and reception are driven by their own baud rate generator.

Figure 63. Word length programming

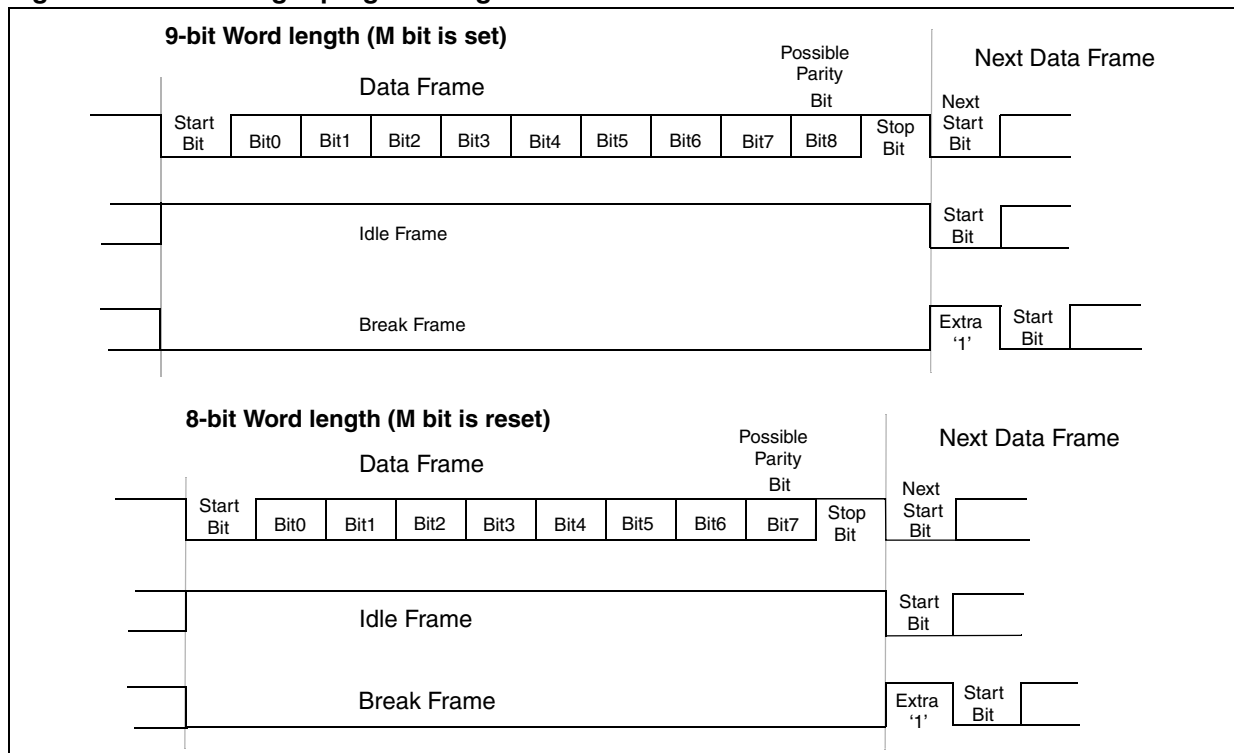

15.4.2 Transmitter

The transmitter can send data words of either 8 or 9 bits depending on the M bit status. When the M bit is set, word length is 9 bits and the 9th bit (the MSB) has to be stored in the T8 bit in the SCICR1 register.

Character transmission

During an SCI transmission, data shifts out least significant bit first on the TDO pin. In this mode, the SCIDR register consists of a buffer (TDR) between the internal bus and the transmit shift register (see [Figure 62](#)).

Procedure

1. Select the M bit to define the word length.
2. Select the desired baud rate using the SCIBRR and the SCIETPR registers.
3. Set the TE bit to assign the TDO pin to the alternate function and to send an idle frame as first transmission.
4. Access the SCISR register and write the data to send in the SCIDR register (this sequence clears the TDRE bit). Repeat this sequence for each data to be transmitted.

Clearing the TDRE bit is always performed by the following software sequence:

1. An access to the SCISR register
2. A write to the SCIDR register

The TDRE bit is set by hardware and it indicates:

- The TDR register is empty.
- The data transfer is beginning.
- The next data can be written in the SCIDR register without overwriting the previous data.

This flag generates an interrupt if the TIE bit is set and the I bit is cleared in the CCR register.

When a transmission is taking place, a write instruction to the SCIDR register stores the data in the TDR register and which is copied in the shift register at the end of the current transmission.

When no transmission is taking place, a write instruction to the SCIDR register places the data directly in the shift register, the data transmission starts, and the TDRE bit is immediately set.

When a frame transmission is complete (after the stop bit) the TC bit is set and an interrupt is generated if the TCIE is set and the I bit is cleared in the CCR register.

Clearing the TC bit is performed by the following software sequence:

1. An access to the SCISR register
2. A write to the SCIDR register

Note: The TDRE and TC bits are cleared by the same software sequence.

Break characters

Setting the SBK bit loads the shift register with a break character. The break frame length depends on the M bit (see [Figure 63](#)).

As long as the SBK bit is set, the SCI send break frames to the TDO pin. After clearing this

bit by software the SCI insert a logic 1 bit at the end of the last break frame to guarantee the recognition of the start bit of the next frame.

Idle characters

Setting the TE bit drives the SCI to send an idle frame before the first data frame.

Clearing and then setting the TE bit during a transmission sends an idle frame after the current word.

Note: *Resetting and setting the TE bit causes the data in the TDR register to be lost. Therefore the best time to toggle the TE bit is when the TDRE bit is set, that is, before writing the next byte in the SCIDR.*

15.4.3 Receiver

The SCI can receive data words of either 8 or 9 bits. When the M bit is set, word length is 9 bits and the MSB is stored in the R8 bit in the SCICR1 register.

Character reception

During a SCI reception, data shifts in least significant bit first through the RDI pin. In this mode, the SCIDR register consists of a buffer (RDR) between the internal bus and the received shift register (see [Figure 62](#)).

Procedure

1. Select the M bit to define the word length.
2. Select the desired baud rate using the SCIBRR and the SCIERPR registers.
3. Set the RE bit, this enables the receiver which begins searching for a start bit.

When a character is received:

- The RDRF bit is set. It indicates that the content of the shift register is transferred to the RDR.
- An interrupt is generated if the RIE bit is set and the I bit is cleared in the CCR register.
- The error flags can be set if a frame error, noise or an overrun error has been detected during reception.

Clearing the RDRF bit is performed by the following software sequence done by:

1. An access to the SCISR register
2. A read to the SCIDR register.

The RDRF bit must be cleared before the end of the reception of the next character to avoid an overrun error.

Break character

When a break character is received, the SCI handles it as a framing error.

Idle character

When an idle frame is detected, there is the same procedure as a data received character plus an interrupt if the ILIE bit is set and the I bit is cleared in the CCR register.

Overrun error

An overrun error occurs when a character is received when RDRF has not been reset. Data cannot be transferred from the shift register to the RDR register as long as the RDRF bit is not cleared.

When an overrun error occurs:

- The OR bit is set.
- The RDR content is not lost.
- The shift register is overwritten.
- An interrupt is generated if the RIE bit is set and the I bit is cleared in the CCR register.

The OR bit is reset by an access to the SCISR register followed by a SCIDR register read operation.

Noise error

Oversampling techniques are used for data recovery by discriminating between valid incoming data and noise. Normal data bits are considered valid if three consecutive samples (8th, 9th, 10th) have the same bit value, otherwise the NF flag is set. In the case of start bit detection, the NF flag is set on the basis of an algorithm combining both valid edge detection and three samples (8th, 9th, 10th). Therefore, to prevent the NF flag getting set during start bit reception, there should be a valid edge detection as well as three valid samples.

When noise is detected in a frame:

- The NF flag is set at the rising edge of the RDRF bit.
- Data is transferred from the Shift register to the SCIDR register.
- No interrupt is generated. However this bit rises at the same time as the RDRF bit which itself generates an interrupt.

The NF flag is reset by a SCISR register read operation followed by a SCIDR register read operation.

During reception, if a false start bit is detected (for example, 8th, 9th, 10th samples are 011, 101, 110), the frame is discarded and the receiving sequence is not started for this frame. There is no RDRF bit set for this frame and the NF flag is set internally (not accessible to the user). This NF flag is accessible along with the RDRF bit when a next valid frame is received.

Note: If the application Start Bit is not long enough to match the above requirements, then the NF Flag may get set due to the short Start Bit. In this case, the NF flag may be ignored by the application software when the first valid byte is received.

See also [Noise error causes on page 145](#).

Figure 64. SCI baud rate and extended prescaler block diagram

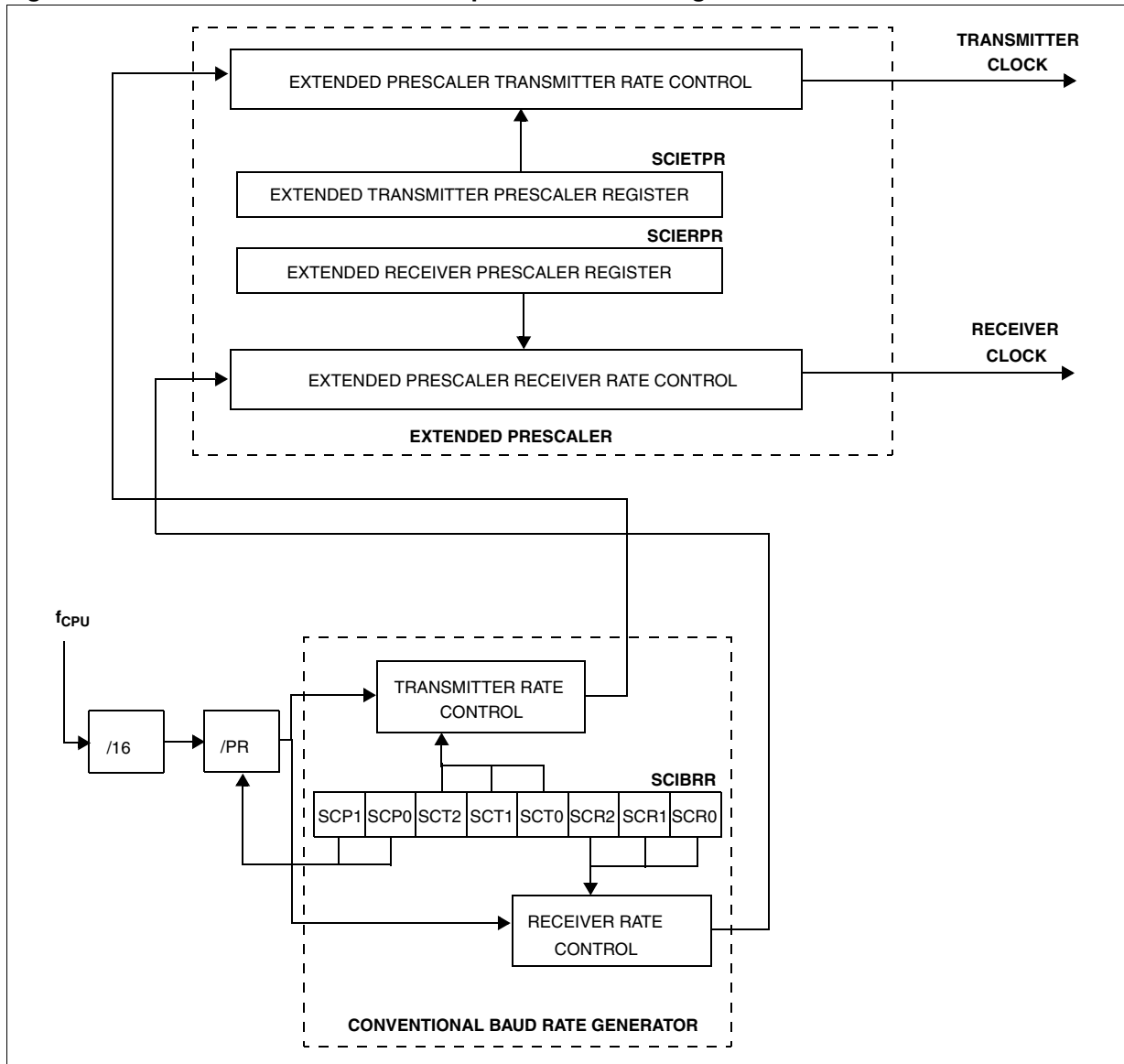

Framing error

A framing error is detected when:

- The stop bit is not recognized on reception at the expected time, following either a de-synchronization or excessive noise.
- A break is received.

When the framing error is detected:

- The FE bit is set by hardware.
- Data is transferred from the Shift register to the SCIDR register.
- No interrupt is generated. However this bit rises at the same time as the RDRF bit which itself generates an interrupt.

The FE bit is reset by a SCISR register read operation followed by a SCIDR register read operation.

Conventional baud rate generation

The baud rate for the receiver and transmitter (Rx and Tx) are set independently and calculated as follows:

$$T_x = \frac{f_{\text{CPU}}}{(16 \cdot \text{PR}) \cdot \text{TR}} \quad R_x = \frac{f_{\text{CPU}}}{(16 \cdot \text{PR}) \cdot \text{RR}}$$

with:

PR = 1, 3, 4 or 13 (see SCP[1:0] bits)

TR = 1, 2, 4, 8, 16, 32, 64, 128 (see SCT[2:0] bits)

RR = 1, 2, 4, 8, 16, 32, 64, 128 (see SCR[2:0] bits)

All these bits are in the SCIBRR register.

Example: If f_{CPU} is 8 MHz (normal mode) and if PR = 13 and TR = RR = 1, the transmit and receive baud rates are 38400 baud.

Note: The baud rate registers **MUST NOT** be changed while the transmitter or the receiver is enabled.

Extended baud rate generation

The extended prescaler option provides a very fine tuning of the baud rate, using a 255 value prescaler, whereas the conventional baud rate generator retains industry standard software compatibility.

The extended baud rate generator block diagram is described in the [Figure 64](#).

The output clock rate sent to the transmitter or to the receiver is the output from the 16 divider divided by a factor ranging from 1 to 255 set in the SCIERPR or the SCIETPR register.

Note: The extended prescaler is activated by setting the SCIETPR or SCIERPR register to a value other than zero. The baud rates are calculated as follows:

$$T_x = \frac{f_{\text{CPU}}}{16 \cdot \text{ETPR} \cdot (\text{PR} \cdot \text{TR})} \quad R_x = \frac{f_{\text{CPU}}}{16 \cdot \text{ERPR} \cdot (\text{PR} \cdot \text{RR})}$$

with:

ETPR = 1,...,255 (see SCIETPR register)

ERPR = 1,...,255 (see SCIERPR register)

Receiver muting and wake-up feature

In multiprocessor configurations it is often desirable that only the intended message recipient should actively receive the full message contents, thus reducing redundant SCI service overhead for all non-addressed receivers.

The non-addressed devices may be placed in sleep mode by means of the muting function.

Setting the RWU bit by software puts the SCI in sleep mode:

- All the reception status bits cannot be set.
- All the receive interrupts are inhibited.

A muted receiver may be awakened by one of the following two ways:

- by Idle Line detection if the WAKE bit is reset
- by Address Mark detection if the WAKE bit is set

A receiver wakes up by Idle Line detection when the Receive line has recognized an Idle Frame. Then the RWU bit is reset by hardware but the IDLE bit is not set.

Receiver wakes up by Address Mark detection when it received a '1' as the most significant bit of a word, thus indicating that the message is an address. The reception of this particular word wakes up the receiver, resets the RWU bit and sets the RDRF bit, which allows the receiver to receive this word normally and to use it as an address word.

Caution: In Mute mode, do not write to the SCICR2 register. If the SCI is in Mute mode during the read operation (RWU = 1) and a address mark wake-up event occurs (RWU is reset) before the write operation, the RWU bit is set again by this write operation. Consequently the address byte is lost and the SCI is not woken up from Mute mode.

Parity control

Parity control (generation of parity bit in transmission and parity checking in reception) can be enabled by setting the PCE bit in the SCICR1 register. Depending on the frame length defined by the M bit, the possible SCI frame formats are as listed in [Table 70](#).

Table 70. Frame formats

M bit	PCE bit	SCI frame
0	0	SB 8 bit data STB
0	1	SB 7-bit data PB STB
1	0	SB 9-bit data STB
1	1	SB 8-bit data PB STB

Legend: SB = Start Bit, STB = Stop Bit, PB = Parity Bit

Note: In case of wake-up by an address mark, the MSB bit of the data is taken into account and not the parity bit

Even parity: the parity bit is calculated to obtain an even number of '1's inside the frame made of the 7 or 8 LSB bits (depending on whether M is equal to 0 or 1) and the parity bit.

Example: data = 00110101; 4 bits set => parity bit is 0 if even parity is selected (PS bit = 0).

Odd parity: the parity bit is calculated to obtain an odd number of '1's inside the frame made of the 7 or 8 LSB bits (depending on whether M is equal to 0 or 1) and the parity bit.

Example: data = 00110101; 4 bits set => parity bit is 1 if odd parity is selected (PS bit = 1).

Transmission mode: If the PCE bit is set then the MSB bit of the data written in the data register is not transmitted but is changed by the parity bit.

Reception mode: If the PCE bit is set then the interface checks if the received data byte has an even number of '1's if even parity is selected (PS = 0) or an odd number of '1's if odd parity is selected (PS = 1). If the parity check fails, the PE flag is set in the SCISR register and an interrupt is generated if PIE is set in the SCICR1 register.

SCI clock tolerance

During reception, each bit is sampled 16 times. The majority of the 8th, 9th and 10th samples is considered as the bit value. For a valid bit detection, all the three samples should have the same value otherwise the noise flag (NF) is set. For example: If the 8th, 9th and 10th samples are 0, 1 and 1 respectively, then the bit value is '1', but the Noise Flag bit is set because the three samples values are not the same.

Consequently, the bit length must be long enough so that the 8th, 9th and 10th samples have the desired bit value. This means the clock frequency should not vary more than 6/16 (37.5%) within one bit. The sampling clock is resynchronized at each start bit, so that when receiving 10 bits (one start bit, 1 data byte, 1 stop bit), the clock deviation must not exceed 3.75%.

Note: The internal sampling clock of the microcontroller samples the pin value on every falling edge. Therefore, the internal sampling clock and the time the application expects the sampling to take place may be out of sync. For example: If the baud rate is 15.625 Kbaud (bit length is 64µs), then the 8th, 9th and 10th samples are at 28µs, 32µs and 36µs respectively (the first sample starting ideally at 0µs). But if the falling edge of the internal clock occurs just before the pin value changes, the samples would then be out of sync by ~4µs. This means the entire bit length must be at least 40µs (36µs for the 10th sample + 4µs for synchronization with the internal sampling clock).

Clock deviation causes

The causes which contribute to the total deviation are:

- D_{TRA} : Deviation due to transmitter error (Local oscillator error of the transmitter or the transmitter is transmitting at a different baud rate).
- D_{QUANT} : Error due to the baud rate quantization of the receiver.
- D_{REC} : Deviation of the local oscillator of the receiver: This deviation can occur during the reception of one complete SCI message assuming that the deviation has been compensated at the beginning of the message.
- D_{TCL} : Deviation due to the transmission line (generally due to the transceivers)

All the deviations of the system should be added and compared to the SCI clock tolerance:

$$D_{TRA} + D_{QUANT} + D_{REC} + D_{TCL} < 3.75\%$$

Noise error causes

See also description of noise error in [Receiver on page 140](#).

Start bit

The noise flag (NF) is set during start bit reception if one of the following conditions occurs:

1. A valid falling edge is not detected. A falling edge is considered to be valid if the 3 consecutive samples before the falling edge occurs are detected as '1' and, after the falling edge occurs, during the sampling of the 16 samples, if one of the samples numbered 3, 5 or 7 is detected as a '1'.
2. During sampling of the 16 samples, if one of the samples numbered 8, 9 or 10 is detected as a '1'.

Therefore, a valid Start Bit must satisfy both the above conditions to prevent the Noise Flag getting set.

Data bits

The noise flag (NF) is set during normal data bit reception if the following condition occurs:

- During the sampling of 16 samples, if all three samples numbered 8, 9 and 10 are not the same. The majority of the 8th, 9th and 10th samples is considered as the bit value.

Therefore, a valid Data Bit must have samples 8, 9 and 10 at the same value to prevent the Noise Flag from getting set.

Figure 65. Bit sampling in reception mode

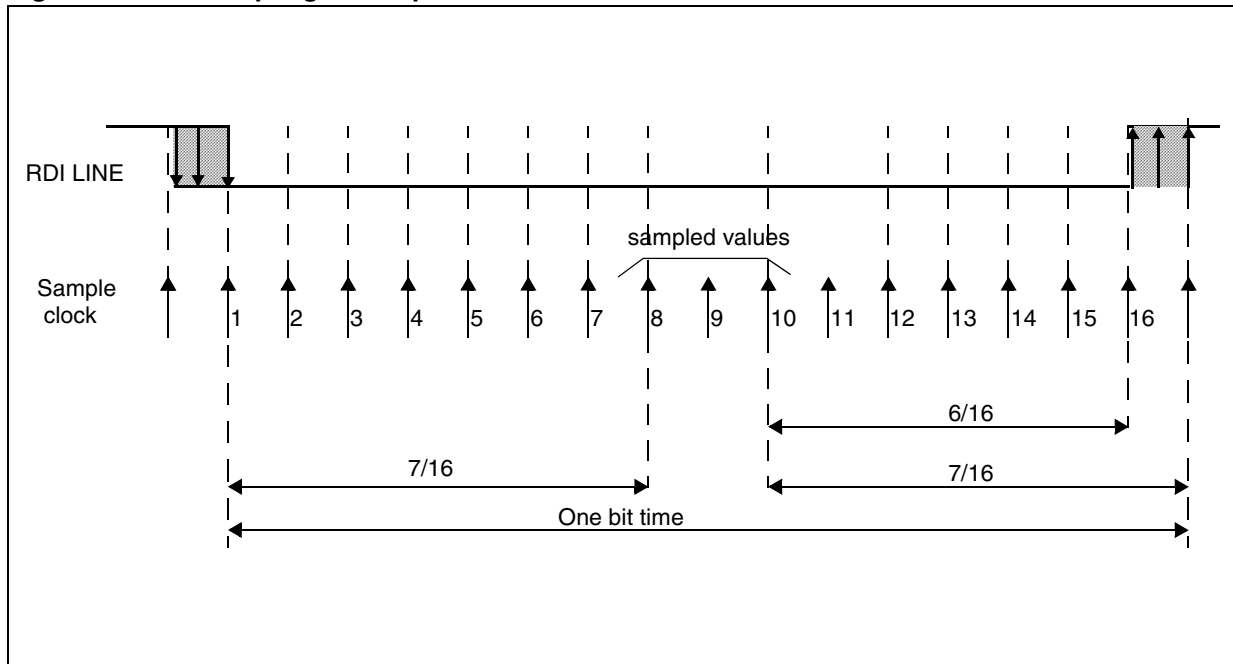

15.5 Low power modes

Table 71. Effect of low power modes on SCI

Mode	Effect
Wait	No effect on SCI. SCI interrupts cause the device to exit from Wait mode.
Halt	SCI registers are frozen. In Halt mode, the SCI stops transmitting/receiving until Halt mode is exited.

15.6 Interrupts

The SCI interrupt events are connected to the same interrupt vector.

These events generate an interrupt if the corresponding Enable Control Bit is set and the interrupt mask in the CC register is reset (RIM instruction).

Table 72. SCI interrupt control/wake-up capability

Interrupt event	Event flag	Enable control bit	Exit from Wait	Exit from Halt
Transmit Data Register Empty	TDRE	TIE	Yes	No
Transmission Complete	TC	TCIE	Yes	No
Received Data Ready to be Read	RDRF	RIE	Yes	No
Overrun Error Detected	OR		Yes	No

Table 72. SCI interrupt control/wake-up capability

Interrupt event	Event flag	Enable control bit	Exit from Wait	Exit from Halt
Idle Line Detected	IDLE	ILIE	Yes	No
Parity Error	PE	PIE	Yes	No

15.7 SCI registers

15.7.1 Status register (SCISR)

SCISR Reset value: 1100 0000 (C0h)

7	6	5	4	3	2	1	0
TDRE	TC	RDRF	IDLE	OR	NF	FE	PE
RO	RO	RO	RO	RO	RO	RO	RO

Table 73. SCISR register description

Bit	Name	Function
7	TDRE	<p><i>Transmit data register empty</i></p> <p>This bit is set by hardware when the content of the TDR register has been transferred into the shift register. An interrupt is generated if the TIE bit = 1 in the SCICR2 register. It is cleared by a software sequence (an access to the SCISR register followed by a write to the SCIDR register).</p> <p>0: Data is not transferred to the shift register 1: Data is transferred to the shift register</p> <p><i>Note: Data is not transferred to the shift register unless the TDRE bit is cleared.</i></p>
6	TC	<p><i>Transmission complete</i></p> <p>This bit is set by hardware when transmission of a frame containing Data is complete. An interrupt is generated if TCIE = 1 in the SCICR2 register. It is cleared by a software sequence (an access to the SCISR register followed by a write to the SCIDR register).</p> <p>0: Transmission is not complete 1: Transmission is complete</p> <p><i>Note: TC is not set after the transmission of a Preamble or a Break.</i></p>
5	RDRF	<p><i>Received data ready flag</i></p> <p>This bit is set by hardware when the content of the RDR register has been transferred to the SCIDR register. An interrupt is generated if RIE = 1 in the SCICR2 register. It is cleared by a software sequence (an access to the SCISR register followed by a read to the SCIDR register).</p> <p>0: Data is not received 1: Received data is ready to be read</p>

Table 73. SCISR register description (continued)

Bit	Name	Function
4	IDLE	<p><i>Idle line detect</i></p> <p>This bit is set by hardware when an Idle Line is detected. An interrupt is generated if the ILIE = 1 in the SCICR2 register. It is cleared by a software sequence (an access to the SCISR register followed by a read to the SCIDR register).</p> <p>0: No Idle Line is detected 1: Idle Line is detected</p> <p><i>Note: The IDLE bit is not set again until the RDRF bit has been set itself (that is, a new idle line occurs).</i></p>
3	OR	<p><i>Overrun error</i></p> <p>This bit is set by hardware when the word currently being received in the shift register is ready to be transferred into the RDR register while RDRF = 1. An interrupt is generated if RIE = 1 in the SCICR2 register. It is cleared by a software sequence (an access to the SCISR register followed by a read to the SCIDR register).</p> <p>0: No Overrun error 1: Overrun error is detected</p> <p><i>Note: When this bit is set RDR register content is not lost but the shift register is overwritten.</i></p>
2	NF	<p><i>Noise flag</i></p> <p>This bit is set by hardware when noise is detected on a received frame. It is cleared by a software sequence (an access to the SCISR register followed by a read to the SCIDR register).</p> <p>0: No noise is detected 1: Noise is detected</p> <p><i>Note: This bit does not generate interrupt as it appears at the same time as the RDRF bit which itself generates an interrupt.</i></p>
1	FE	<p><i>Framing error</i></p> <p>This bit is set by hardware when a de-synchronization, excessive noise or a break character is detected. It is cleared by a software sequence (an access to the SCISR register followed by a read to the SCIDR register).</p> <p>0: No Framing error is detected 1: Framing error or break character is detected</p> <p><i>Note: This bit does not generate interrupt as it appears at the same time as the RDRF bit which itself generates an interrupt. If the word currently being transferred causes both frame error and overrun error, it will be transferred and only the OR bit will be set.</i></p>
0	PE	<p><i>Parity error</i></p> <p>This bit is set by hardware when a parity error occurs in receiver mode. It is cleared by a software sequence (a read to the status register followed by an access to the SCIDR data register). An interrupt is generated if PIE = 1 in the SCICR1 register.</p> <p>0: No parity error 1: Parity error</p>

15.7.2 Control register 1 (SCICR1)

SCICR1							Reset value: X000 0000 (x0h)
7	6	5	4	3	2	1	0
R8	T8	SCID	M	WAKE	PCE	PS	PIE
RW	RW	RW	RW	RW	RW	RW	RW

Table 74. SCICR1 register description

Bit	Name	Function
7	R8	<i>Receive data bit 8</i> This bit is used to store the 9th bit of the received word when M = 1.
6	T8	<i>Transmit data bit 8</i> This bit is used to store the 9th bit of the transmitted word when M = 1.
5	SCID	<i>Disabled for low power consumption</i> When this bit is set the SCI prescalers and outputs are stopped and the end of the current byte transfer in order to reduce power consumption. This bit is set and cleared by software. 0: SCI enabled 1: SCI prescaler and outputs disabled
4	M	<i>Word length</i> This bit determines the word length. It is set or cleared by software. 0: 1 Start bit, 8 Data bits, 1 Stop bit 1: 1 Start bit, 9 Data bits, 1 Stop bit <i>Note: The M bit must not be modified during a data transfer (both transmission and reception).</i>
3	WAKE	<i>Wake-up method</i> This bit determines the SCI wake-up method. It is set or cleared by software. 0: Idle line 1: Address mark
2	PCE	<i>Parity control enable</i> This bit selects the hardware parity control (generation and detection). When the parity control is enabled, the computed parity is inserted at the MSB position (9th bit if M = 1; 8th bit if M = 0) and parity is checked on the received data. This bit is set and cleared by software. Once it is set, PCE is active after the current byte (in reception and in transmission). 0: Parity control disabled 1: Parity control enabled
1	PS	<i>Parity selection</i> This bit selects the odd or even parity when the parity generation/detection is enabled (PCE bit set). It is set and cleared by software. The parity is selected after the current byte. 0: Even parity 1: Odd parity

Table 74. SCICR1 register description (continued)

Bit	Name	Function
0	PIE	<p><i>Parity interrupt enable</i></p> <p>This bit enables the interrupt capability of the hardware parity control when a parity error is detected (PE bit set). It is set and cleared by software.</p> <p>0: Parity error interrupt disabled 1: Parity error interrupt enabled</p>

15.7.3 Control register 2 (SCICR2)

SCICR2							Reset value: 0000 0000 (00h)	
7	6	5	4	3	2	1	0	
TIE	TCIE	RIE	ILIE	TE	RE	RWU	SBK	
RW	RW	RW	RW	RW	RW	RW	RW	

Table 75. SCICR2 register description

Bit	Name	Function
7	TIE	<p><i>Transmitter interrupt enable</i></p> <p>This bit is set and cleared by software.</p> <p>0: Interrupt is inhibited 1: An SCI interrupt is generated whenever TDRE = 1 in the SCISR register.</p>
6	TCIE	<p><i>Transmission complete interrupt enable</i></p> <p>This bit is set and cleared by software.</p> <p>0: Interrupt is inhibited 1: An SCI interrupt is generated whenever TC = 1 in the SCISR register.</p>
5	RIE	<p><i>Receiver interrupt enable</i></p> <p>This bit is set and cleared by software.</p> <p>0: Interrupt is inhibited 1: An SCI interrupt is generated whenever OR = 1 or RDRF = 1 in the SCISR register.</p>
4	ILIE	<p><i>Idle line interrupt enable</i></p> <p>This bit is set and cleared by software.</p> <p>0: Interrupt is inhibited 1: An SCI interrupt is generated whenever IDLE = 1 in the SCISR register.</p>
3	TE	<p><i>Transmitter enable</i></p> <p>This bit enables the transmitter. It is set and cleared by software.</p> <p>0: Transmitter is disabled 1: Transmitter is enabled</p> <p><i>Notes:</i></p> <p><i>During transmission, a '0' pulse on the TE bit ('0' followed by '1') sends a preamble (idle line) after the current word.</i></p> <p><i>When TE is set there is a 1 bit-time delay before the transmission starts.</i></p> <p>Caution: The TDO pin is free for general purpose I/O only when the TE and RE bits are both cleared (or if TE is never set).</p>

Table 75. SCICR2 register description (continued)

Bit	Name	Function
2	RE	<p><i>Receiver enable</i></p> <p>This bit enables the receiver. It is set and cleared by software. 0: Receiver is disabled 1: Receiver is enabled and begins searching for a start bit</p>
1	RWU	<p><i>Receiver wake-up</i></p> <p>This bit determines if the SCI is in mute mode or not. It is set and cleared by software and can be cleared by hardware when a wake-up sequence is recognized. 0: Receiver in Active mode 1: Receiver in Mute mode</p> <p><i>Note: Before selecting Mute mode (setting the RWU bit), the SCI must receive some data first, otherwise it cannot function in Mute mode with wake-up by idle line detection.</i></p>
0	SBK	<p><i>Send break</i></p> <p>This bit set is used to send break characters. It is set and cleared by software. 0: No break character is transmitted 1: Break characters are transmitted</p> <p><i>Note: If the SBK bit is set to '1' and then to '0', the transmitter sends a BREAK word at the end of the current word.</i></p>

15.7.4 Data register (SCIDR)

This register contains the Received or Transmitted data character, depending on whether it is read from or written to.

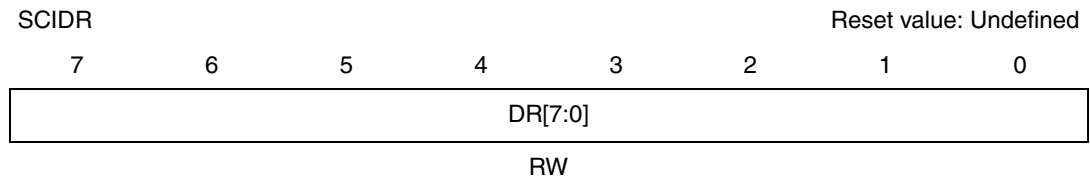

The Data register performs a double function (read and write) since it is composed of two registers, one for transmission (TDR) and one for reception (RDR).

The TDR register provides the parallel interface between the internal bus and the output shift register (see [Figure 62](#)).

The RDR register provides the parallel interface between the input shift register and the internal bus (see [Figure 62](#)).

15.7.5 Baud rate register (SCIBRR)

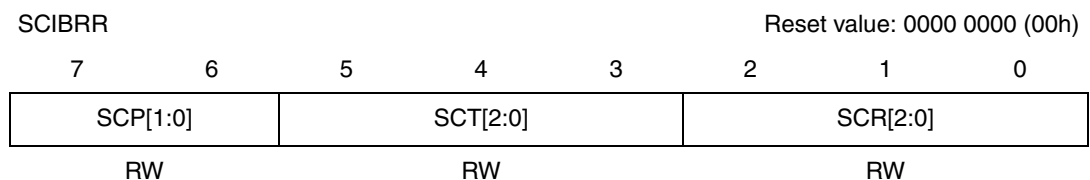

Table 76. SCIBRR register description

Bit	Name	Function
7:6	SCP[1:0]	<p><i>First SCI Prescaler</i></p> <p>These 2 prescaling bits allow several standard clock division ranges.</p> <p>00: PR prescaling factor = 1 01: PR prescaling factor = 3 10: PR prescaling factor = 4 11: PR prescaling factor = 13</p>
5:3	SCT[2:0]	<p><i>SCI Transmitter rate divisor</i></p> <p>These 3 bits, in conjunction with the SCP1 and SCP0 bits define the total division applied to the bus clock to yield the transmit rate clock in conventional Baud Rate Generator mode.</p> <p>000: TR dividing factor = 1 001: TR dividing factor = 2 010: TR dividing factor = 4 011: TR dividing factor = 8 100: TR dividing factor = 16 101: TR dividing factor = 32 110: TR dividing factor = 64 111: TR dividing factor = 128</p>
2:0	SCR[2:0]	<p><i>SCI Receiver rate divisor</i></p> <p>These 3 bits, in conjunction with the SCP[1:0] bits define the total division applied to the bus clock to yield the receive rate clock in conventional Baud Rate Generator mode.</p> <p>000: RR dividing factor = 1 001: RR dividing factor = 2 010: RR dividing factor = 4 011: RR dividing factor = 8 100: RR dividing factor = 16 101: RR dividing factor = 32 110: RR dividing factor = 64 111: RR dividing factor = 128</p>

15.7.6 Extended receive prescaler division register (SCIERPR)

This register allows setting of the extended prescaler rate division factor for the receive circuit.

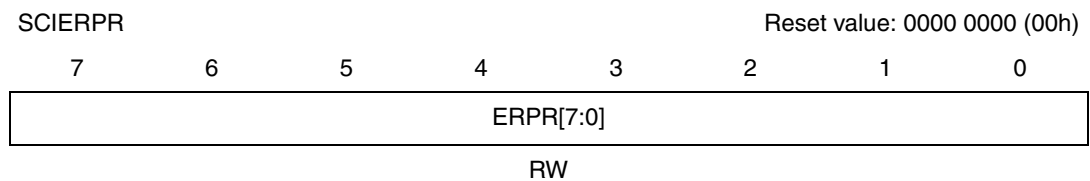

Table 77. SCIERPR register description

Bit	Name	Function
7:0	ERPR[7:0]	<p><i>8-bit Extended Receive Prescaler Register</i></p> <p>The extended baud rate generator is activated when a value different from 00h is stored in this register. Therefore the clock frequency issued from the 16 divider (see Figure 64) is divided by the binary factor set in the SCIERPR register (in the range 1 to 255).</p> <p>The extended baud rate generator is not used after a reset.</p>

15.7.7 Extended transmit prescaler division register (SCIETPR)

This register allows setting of the external prescaler rate division factor for the transmit circuit.

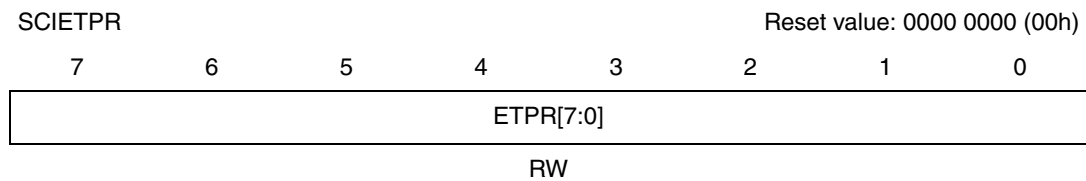

Table 78. SCIETPR register description

Bit	Name	Function
7:0	ETPR[7:0]	<p><i>8-bit Extended Transmit Prescaler Register</i></p> <p>The extended baud rate generator is activated when a value different from 00h is stored in this register. Therefore the clock frequency issued from the 16 divider (see Figure 64) is divided by the binary factor set in the SCIETPR register (in the range 1 to 255).</p> <p>The extended baud rate generator is not used after a reset.</p>

Table 79. Baud rate selection

Symbol	Parameter	Conditions			Standard	Baud rate	Unit
		f _{CPU}	Accuracy versus standard	Prescaler			
f _{Tx} f _{Rx}	Communication frequency	8 MHz	~0.16%	Conventional mode	300	~300.48	Hz
				TR (or RR) = 128, PR = 13 TR (or RR) = 32, PR = 13 TR (or RR) = 16, PR = 13 TR (or RR) = 8, PR = 13 TR (or RR) = 4, PR = 13 TR (or RR) = 16, PR = 3 TR (or RR) = 2, PR = 13 TR (or RR) = 1, PR = 13			
			~0.79%	Extended mode	14400	~14285.71	
				ETPR (or ERPR) = 35, TR (or RR) = 1, PR = 1			

Table 80. SCI register map and reset values

Address (Hex.)	Register label	7	6	5	4	3	2	1	0
0050h	SCISR Reset value	TDRE 1	TC 1	RDRF 0	IDLE 0	OR 0	NF 0	FE 0	PE 0
0051h	SCIDR Reset value	MSB x	x	x	x	x	x	x	LSB x
0052h	SCIBRR Reset value	SCP1 0	SCP0 0	SCT2 0	SCT1 0	SCT0 0	SCR2 0	SCR1 0	SCR0 0
0053h	SCICR1 Reset value	R8 x	T8 0	SCID 0	M 0	WAKE 0	PCE 0	PS 0	PIE 0
0054h	SCICR2 Reset value	TIE 0	TCIE 0	RIE 0	ILIE 0	TE 0	RE 0	RWU 0	SBK 0
0055h	SCIERPR Reset value	MSB 0	0	0	0	0	0	0	LSB 0
0057h	SCIPETPR Reset value	MSB 0	0	0	0	0	0	0	LSB 0

16 I²C bus interface (I2C)

16.1 Introduction

The I²C bus interface serves as an interface between the microcontroller and the serial I²C bus. It provides both multimaster and slave functions, and controls all I²C bus-specific sequencing, protocol, arbitration and timing. It supports fast I²C mode (400 kHz).

16.2 Main features

- Parallel-bus/I²C protocol converter
- Multimaster capability
- 7-bit/10-bit addressing
- SMBus V1.1 compliant
- Transmitter/Receiver flag
- End-of-byte transmission flag
- Transfer problem detection

16.2.1 I²C master features

- Clock generation
- I²C bus busy flag
- Arbitration Lost flag
- End of byte transmission flag
- Transmitter/Receiver flag
- Start bit detection flag
- Start and Stop generation

16.2.2 I²C slave features

- Stop bit detection
- I²C bus busy flag
- Detection of misplaced start or stop condition
- Programmable I²C address detection
- Transfer problem detection
- End-of-byte transmission flag
- Transmitter/Receiver flag

16.3 General description

In addition to receiving and transmitting data, this interface converts it from serial to parallel format and vice versa, using either an interrupt or polled handshake. The interrupts are enabled or disabled by software. The interface is connected to the I²C bus by a data pin (SDA) and by a clock pin (SCL). It can be connected both with a standard I²C bus and a fast I²C bus. This selection is made by software.

16.3.1 Mode selection

The interface can operate in the four following modes:

- Slave transmitter/receiver
- Master transmitter/receiver

By default, it operates in slave mode.

The interface automatically switches from slave to master after it generates a START condition and from master to slave in case of arbitration loss or a STOP generation, allowing then Multimaster capability.

16.3.2 Communication flow

In Master mode, it initiates a data transfer and generates the clock signal. A serial data transfer always begins with a start condition and ends with a stop condition. Both start and stop conditions are generated in master mode by software.

In Slave mode, the interface is capable of recognizing its own address (7- or 10-bit), and the General Call address. The General Call address detection may be enabled or disabled by software.

Data and addresses are transferred as 8-bit bytes, MSB first. The first byte(s) following the start condition contain the address (one in 7-bit mode, two in 10-bit mode). The address is always transmitted in Master mode.

A 9th clock pulse follows the 8 clock cycles of a byte transfer, during which the receiver must send an acknowledge bit to the transmitter. Refer to [Figure 66](#).

Figure 66. I²C bus protocol

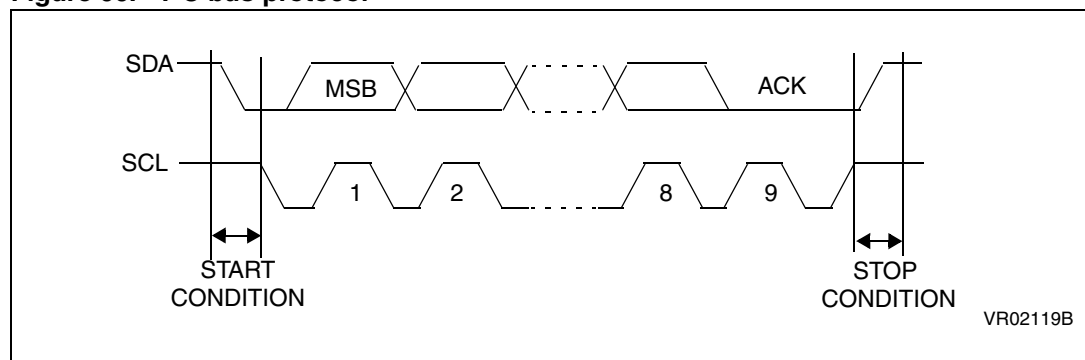

Acknowledge may be enabled and disabled by software.

The I²C interface address and/or general call address can be selected by software.

The speed of the I²C interface may be selected between standard (up to 100 kHz) and fast I²C (up to 400 kHz).

16.3.3 SDA/SCL line control

Transmitter mode

The interface holds the clock line low before transmission to wait for the microcontroller to write the byte in the data register.

Receiver mode

The interface holds the clock line low after reception to wait for the microcontroller to read the byte in the data register.

The SCL frequency (f_{SCL}) is controlled by a programmable clock divider which depends on the I²C bus mode.

When the I²C cell is enabled, the SDA and SCL ports must be configured as floating inputs. In this case, the value of the external pull-up resistor used depends on the application.

When the I²C cell is disabled, the SDA and SCL ports revert to being standard I/O port pins.

Figure 67. I²C interface block diagram

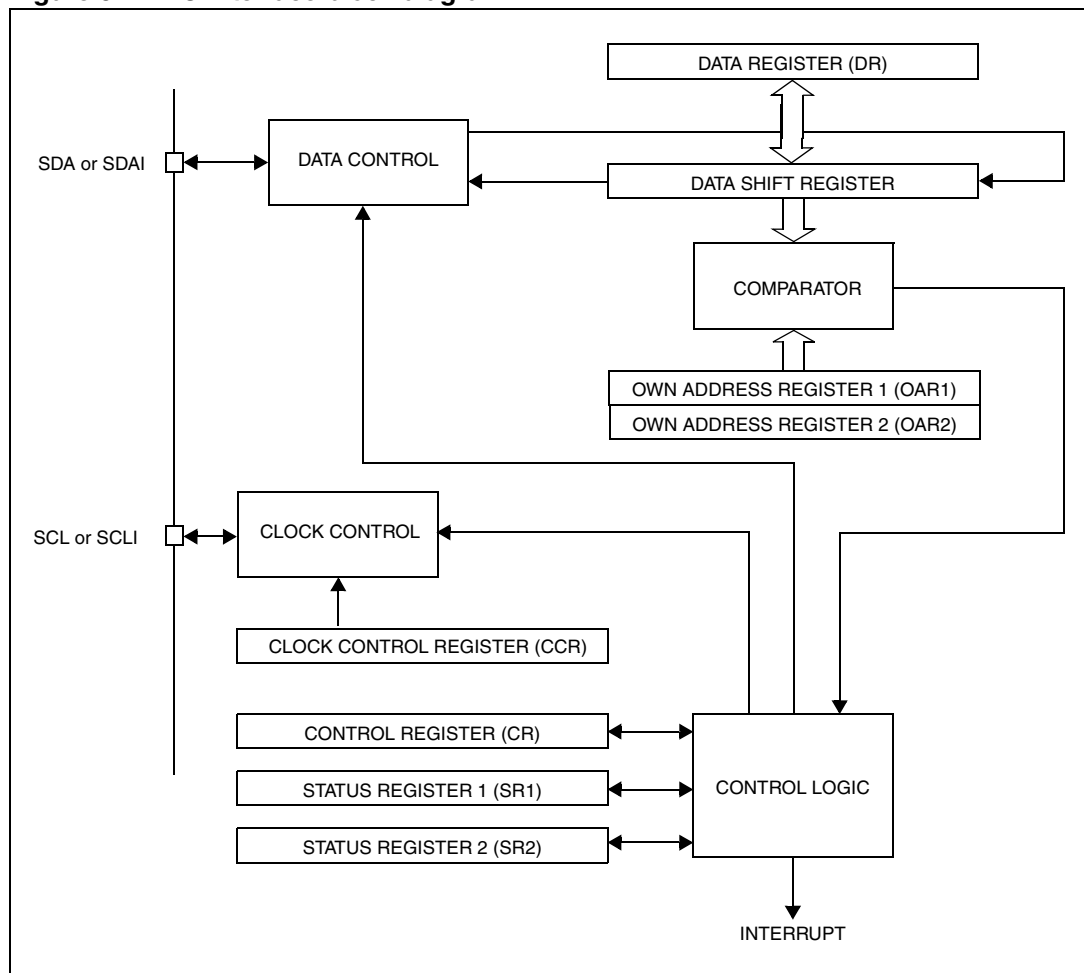

16.4 Functional description

Refer to the CR, SR1 and SR2 registers in [Section 16.7](#) for the bit definitions.

By default the I²C interface operates in Slave mode (M/SL bit is cleared) except when it initiates a transmit or receive sequence.

First the interface frequency must be configured using the FRi bits in the OAR2 register.

16.4.1 Slave mode

As soon as a start condition is detected, the address is received from the SDA line and sent to the shift register; then it is compared with the address of the interface or the General Call address (if selected by software).

Note: In 10-bit addressing mode, the comparison includes the header sequence (11110xx0) and the two most significant bits of the address.

Header matched (10-bit mode only): The interface generates an acknowledge pulse if the ACK bit is set.

Address not matched: The interface ignores it and waits for another Start condition.

Address matched: The interface generates in sequence:

- an acknowledge pulse if the ACK bit is set
- EVF and ADSL bits are set with an interrupt if the ITE bit is set.

Then the interface waits for a read of the SR1 register, **holding the SCL line low** (see [Figure 68: Transfer sequencing EV1](#)).

Next, in 7-bit mode read the DR register to determine from the least significant bit (Data Direction Bit) if the slave must enter Receiver or Transmitter mode.

In 10-bit mode, after receiving the address sequence the slave is always in receive mode. It will enter transmit mode on receiving a repeated Start condition followed by the header sequence with matching address bits and the least significant bit set (11110xx1).

Slave receiver

Following the address reception and after the SR1 register has been read, the slave receives bytes from the SDA line into the DR register via the internal shift register. After each byte the interface generates in sequence:

- an acknowledge pulse if the ACK bit is set
- EVF and BTF bits are set with an interrupt if the ITE bit is set.

Then the interface waits for a read of the SR1 register followed by a read of the DR register, **holding the SCL line low** (see [Figure 68: Transfer sequencing EV2](#)).

Slave transmitter

Following the address reception and after SR1 register has been read, the slave sends bytes from the DR register to the SDA line via the internal shift register.

The slave waits for a read of the SR1 register followed by a write in the DR register, **holding the SCL line low** (see [Figure 68: Transfer sequencing EV3](#)).

When the acknowledge pulse is received:

- The EVF and BTF bits are set by hardware with an interrupt if the ITE bit is set.

Closing slave communication

After the last data byte is transferred, a Stop Condition is generated by the master. The interface detects this condition and sets:

- EVF and STOPF bits with an interrupt if the ITE bit is set.

Then the interface waits for a read of the SR2 register (see [Figure 68: Transfer sequencing EV4](#)).

Error cases

- **BERR**: Detection of a Stop or a Start condition during a byte transfer. In this case, the EVF and the BERR bits are set with an interrupt if the ITE bit is set.
If it is a Stop then the interface discards the data, released the lines and waits for another Start condition.
If it is a Start then the interface discards the data and waits for the next slave address on the bus.
- **AF**: Detection of a non-acknowledge bit. In this case, the EVF and AF bits are set with an interrupt if the ITE bit is set.
The AF bit is cleared by reading the I2CSR2 register. However, if read before the completion of the transmission, the AF flag will be set again, thus possibly generating a new interrupt. Software must ensure either that the SCL line is back at 0 before reading the SR2 register, or be able to correctly handle a second interrupt during the 9th pulse of a transmitted byte.

Note: In case of errors, the SCL line is not held low; however, the SDA line can remain low if the last bits transmitted are all 0. While AF = 1, the SCL line may be held low due to SB or BTF flags that are set at the same time. It is then necessary to release both lines by software.

How to release the SDA / SCL lines

Set and subsequently clear the STOP bit while BTF is set. The SDA/SCL lines are released after the transfer of the current byte.

SMBus compatibility

The ST7 I²C is compatible with the SMBus V1.1 protocol. It supports all SMBus addressing modes, SMBus bus protocols and CRC-8 packet error checking. Refer to *SMBus Slave Driver For ST7 I²C Peripheral* (AN1713).

16.4.2 Master mode

To switch from default Slave mode to Master mode a Start condition generation is needed.

Start condition

Setting the START bit while the BUSY bit is cleared causes the interface to switch to Master mode (M/SL bit set) and generates a Start condition.

Once the Start condition is sent:

- The EVF and SB bits are set by hardware with an interrupt if the ITE bit is set.

Then the master waits for a read of the SR1 register followed by a write in the DR register with the Slave address, **holding the SCL line low** (see [Figure 68: Transfer sequencing EV5](#)).

Slave address transmission

Then the slave address is sent to the SDA line via the internal shift register.

- In 7-bit addressing mode, one address byte is sent.
- In 10-bit addressing mode, sending the first byte including the header sequence causes the following event:
 - The EVF bit is set by hardware with interrupt generation if the ITE bit is set.

Then the master waits for a read of the SR1 register followed by a write in the DR register, **holding the SCL line low** (see [Figure 68: Transfer sequencing](#) EV9).

Then the second address byte is sent by the interface.

After completion of this transfer (and acknowledge from the slave if the ACK bit is set):

- The EVF bit is set by hardware with interrupt generation if the ITE bit is set.

Then the master waits for a read of the SR1 register followed by a write in the CR register (for example set PE bit), **holding the SCL line low** (see [Figure 68: Transfer sequencing](#) EV6).

Next, the master must enter Receiver or Transmitter mode.

Note: In 10-bit addressing mode, to switch the master to Receiver mode, software must generate a repeated Start condition and resend the header sequence with the least significant bit set (11110xx1).

Master receiver

Following the address transmission and after SR1 and CR registers have been accessed, the master receives bytes from the SDA line into the DR register via the internal shift register. After each byte the interface generates in sequence:

- Acknowledge pulse if the ACK bit is set
- EVF and BTF bits are set by hardware with an interrupt if the ITE bit is set.

Then the interface waits for a read of the SR1 register followed by a read of the DR register, **holding the SCL line low** (see [Figure 68: Transfer sequencing](#) EV7).

To close the communication: Before reading the last byte from the DR register, set the STOP bit to generate the Stop condition. The interface goes automatically back to slave mode (M/SL bit cleared).

Note: In order to generate the non-acknowledge pulse after the last received data byte, the ACK bit must be cleared just before reading the second last data byte.

Master transmitter

Following the address transmission and after SR1 register has been read, the master sends bytes from the DR register to the SDA line via the internal shift register.

The master waits for a read of the SR1 register followed by a write in the DR register, **holding the SCL line low** (see [Figure 68: Transfer sequencing](#) EV8).

When the acknowledge bit is received, the interface sets:

- EVF and BTF bits with an interrupt if the ITE bit is set.

To close the communication: After writing the last byte to the DR register, set the STOP bit to generate the Stop condition. The interface goes automatically back to slave mode (M/SL bit cleared).

Error cases

- **BERR:** Detection of a Stop or a Start condition during a byte transfer. In this case, the EVF and BERR bits are set by hardware with an interrupt if ITE is set. Note that BERR will not be set if an error is detected during the first or second pulse of each 9-bit transaction:
 - **Single Master Mode**
If a Start or Stop is issued during the first or second pulse of a 9-bit transaction, the BERR flag will not be set and transfer will continue however the BUSY flag will be reset. To work around this, slave devices should issue a NACK when they receive a misplaced Start or Stop. The reception of a NACK or BUSY by the master in the middle of communication makes it possible to re-initiate transmission.
 - **Multimaster Mode**
Normally the BERR bit would be set whenever unauthorized transmission takes place while transfer is already in progress. However, an issue will arise if an external master generates an unauthorized Start or Stop while the I²C master is on the first or second pulse of a 9-bit transaction. It is possible to work around this by polling the BUSY bit during I²C master mode transmission. The resetting of the BUSY bit can then be handled in a similar manner as the BERR flag being set.
- **AF:** Detection of a non-acknowledge bit. In this case, the EVF and AF bits are set by hardware with an interrupt if the ITE bit is set. To resume, set the Start or Stop bit. The AF bit is cleared by reading the I2CSR2 register. However, if read before the completion of the transmission, the AF flag will be set again, thus possibly generating a new interrupt. Software must ensure either that the SCL line is back at 0 before reading the SR2 register, or be able to correctly handle a second interrupt during the 9th pulse of a transmitted byte.
- **ARLO:** Detection of an arbitration lost condition. In this case the ARLO bit is set by hardware (with an interrupt if the ITE bit is set and the interface goes automatically back to slave mode (the M/SL bit is cleared).

Note: In all these cases, the SCL line is not held low; however, the SDA line can remain low due to possible '0' bits transmitted last. It is then necessary to release both lines by software.

Figure 68. Transfer sequencing

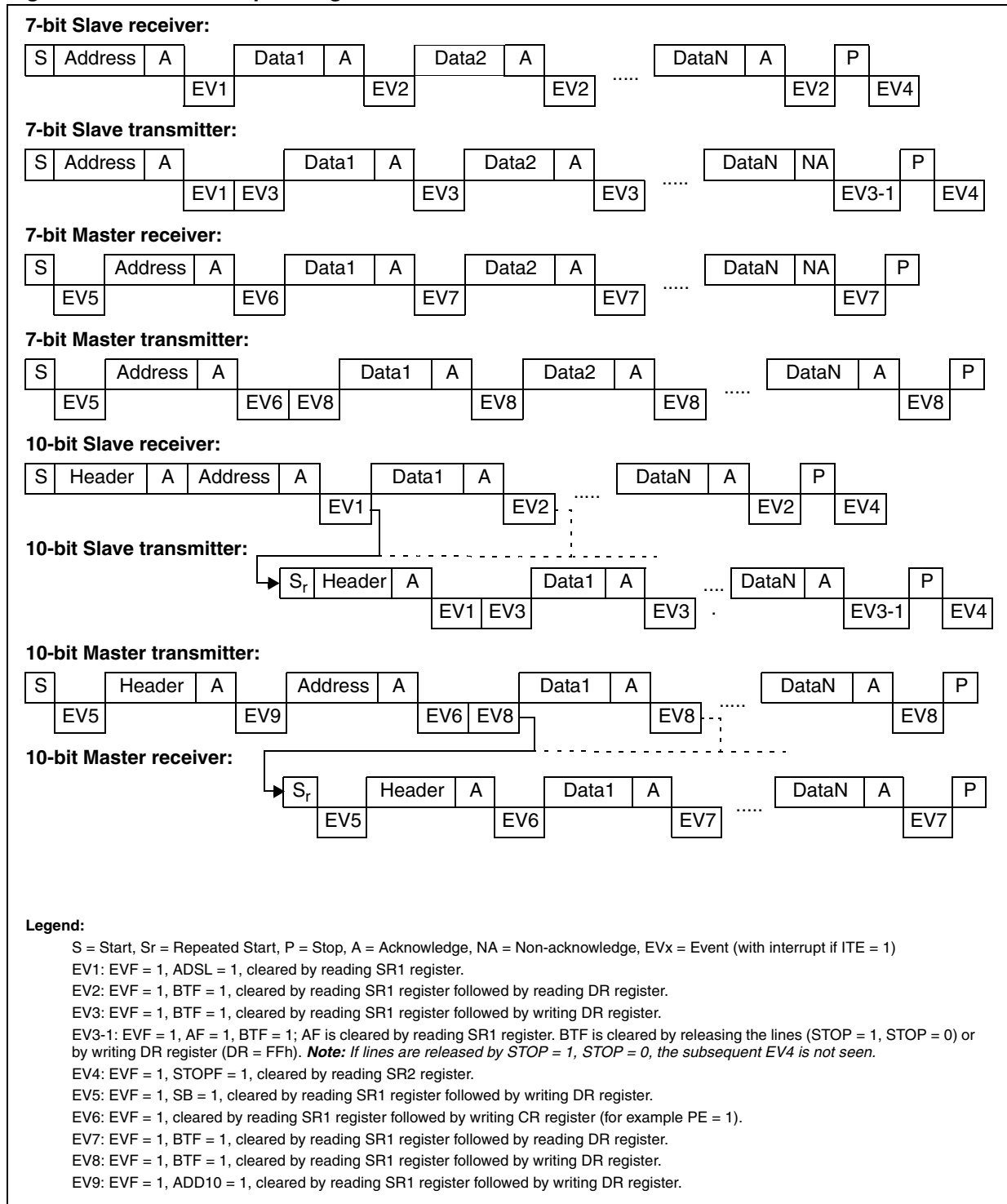

16.5 Low power modes

Table 81. Effect of low power modes on I²C

Mode	Effect
Wait	No effect on I ² C interface. I ² C interrupts cause the device to exit from Wait mode.
Halt	I ² C registers are frozen. In Halt mode, the I ² C interface is inactive and does not acknowledge data on the bus. The I ² C interface resumes operation when the MCU is woken up by an interrupt with “exit from Halt mode” capability.

16.6 Interrupts

Figure 69. Interrupt control logic diagram

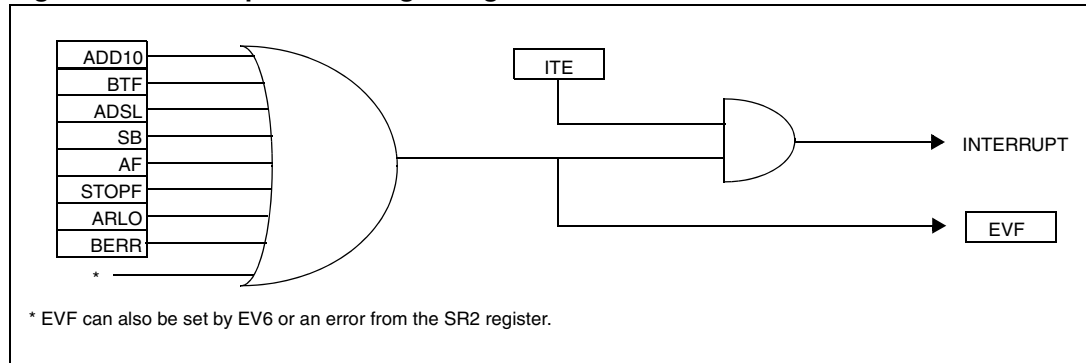

Table 82. I²C interrupt control/wake-up capability

Interrupt event	Event flag	Enable control bit	Exit from Wait	Exit from Halt
10-bit Address Sent Event (Master mode)	ADD10	ITE	Yes	No
End of Byte Transfer Event	BTF			
Address Matched Event (Slave mode)	ADSEL			
Start Bit Generation Event (Master mode)	SB			
Acknowledge Failure Event	AF			
Stop Detection Event (Slave mode)	STOPF			
Arbitration Lost Event (Multimaster configuration)	ARLO			
Bus Error Event	BERR			

Note: The I²C interrupt events are connected to the same interrupt vector (see [Interrupts](#) chapter). They generate an interrupt if the corresponding Enable Control bit is set and the I-bit in the CC register is reset (RIM instruction).

16.7 Register description

16.7.1 I²C control register (CR)

CR	Reset value: 0000 0000 (00h)						
7	6	5	4	3	2	1	0
Reserved	PE	ENGC	START	ACK	STOP	ITE	
-	RW	RW	RW	RW	RW	RW	RW

Table 83. CR register description

Bit	Name	Function
7:6	-	Reserved. Forced to 0 by hardware.
5	PE	<p><i>Peripheral enable</i></p> <p>This bit is set and cleared by software.</p> <p>0: Peripheral disabled 1: Master/Slave capability</p> <p><i>Notes:</i></p> <ul style="list-style-type: none"> - When PE = 0, all the bits of the CR register and the SR register except the Stop bit are reset. All outputs are released while PE = 0 - When PE = 1, the corresponding I/O pins are selected by hardware as alternate functions. <p>To enable the I²C interface, write the CR register TWICE with PE = 1 as the first write only activates the interface (only PE is set).</p>
4	ENGC	<p><i>Enable General Call</i></p> <p>This bit is set and cleared by software. It is also cleared by hardware when the interface is disabled (PE = 0). The 00h General Call address is acknowledged (01h ignored).</p> <p>0: General Call disabled 1: General Call enabled</p> <p><i>Note: In accordance with the I2C standard, when GCAL addressing is enabled, an I2C slave can only receive data. It will not transmit data to the master.</i></p>
3	START	<p><i>Generation of a Start condition</i></p> <p>This bit is set and cleared by software. It is also cleared by hardware when the interface is disabled (PE = 0) or when the Start condition is sent (with interrupt generation if ITE = 1).</p> <p>In Master mode</p> <p>0: No start generation 1: Repeated start generation</p> <p>In Slave mode</p> <p>0: No start generation 1: Start generation when the bus is free</p>
2	ACK	<p><i>Acknowledge enable</i></p> <p>This bit is set and cleared by software. It is also cleared by hardware when the interface is disabled (PE = 0).</p> <p>0: No acknowledge returned 1: Acknowledge returned after an address byte or a data byte is received</p>

Table 83. CR register description (continued)

Bit	Name	Function
1	STOP	<p><i>Generation of a Stop condition</i></p> <p>This bit is set and cleared by software. It is also cleared by hardware in master mode.</p> <p><i>Note: This bit is not cleared when the interface is disabled (PE = 0).</i></p> <p>In Master mode 0: No stop generation 1: Stop generation after the current byte transfer or after the current Start condition is sent. The STOP bit is cleared by hardware when the Stop condition is sent.</p> <p>In Slave mode 0: No stop generation 1: Release the SCL and SDA lines after the current byte transfer (BTF = 1). In this mode the STOP bit has to be cleared by software.</p>
0	ITE	<p><i>Interrupt enable</i></p> <p>This bit is set and cleared by software and cleared by hardware when the interface is disabled (PE = 0).</p> <p>0: Interrupts disabled 1: Interrupts enabled</p> <p>Refer to Figure 69 and Table 82 for the relationship between the events and the interrupt.</p> <p>SCL is held low when the ADD10, SB, BTF or ADSL flags or an EV6 event (see Figure 68) is detected.</p>

16.7.2 I²C status register 1 (SR1)

SR1	Reset value: 0000 0000 (00h)
7 6 5 4 3 2 1 0	
EVF ADD10 TRA BUSY BTF ADSL M/SL SB	
RO RO RO RO RO RO RO RO	

Table 84. SR1 register description

Bit	Name	Function
7	EVF	<p><i>Event flag</i></p> <p>This bit is set by hardware as soon as an event occurs. It is cleared by software reading SR2 register in case of error event or as described in Figure 68. It is also cleared by hardware when the interface is disabled (PE = 0).</p> <p>0: No event 1: One of the following events has occurred:</p> <ul style="list-style-type: none"> - BTF = 1 (Byte received or transmitted) - ADSL = 1 (Address matched in Slave mode while ACK = 1) - SB = 1 (Start condition generated in Master mode) - AF = 1 (No acknowledge received after byte transmission) - STOPF = 1 (Stop condition detected in Slave mode) - ARLO = 1 (Arbitration lost in Master mode) - BERR = 1 (Bus error, misplaced Start or Stop condition detected) - ADD10 = 1 (Master has sent header byte) - Address byte successfully transmitted in Master mode

Table 84. SR1 register description (continued)

Bit	Name	Function
6	ADD10	<p><i>10-bit addressing in Master mode</i></p> <p>This bit is set by hardware when the master has sent the first byte in 10-bit address mode. It is cleared by software reading SR2 register followed by a write in the DR register of the second address byte. It is also cleared by hardware when the peripheral is disabled (PE = 0).</p> <p>0: No ADD10 event occurred. 1: Master has sent first address byte (header)</p>
5	TRA	<p><i>Transmitter/Receiver</i></p> <p>When BTF is set, TRA = 1 if a data byte has been transmitted. It is cleared automatically when BTF is cleared. It is also cleared by hardware after detection of Stop condition (STOPF = 1), loss of bus arbitration (ARLO = 1) or when the interface is disabled (PE = 0).</p> <p>0: Data byte received (if BTF = 1) 1: Data byte transmitted</p>
4	BUSY	<p><i>Bus busy</i></p> <p>This bit is set by hardware on detection of a Start condition and cleared by hardware on detection of a Stop condition. It indicates a communication in progress on the bus. The BUSY flag of the I2CSR1 register is cleared if a Bus Error occurs.</p> <p>0: No communication on the bus 1: Communication ongoing on the bus</p> <p><i>Note: The BUSY flag is NOT updated when the interface is disabled (PE = 0). This can have consequences when operating in Multimaster mode; that is, a second active I²C master commencing a transfer with an unset BUSY bit can cause a conflict resulting in lost data. A software workaround consists of checking that the I²C is not busy before enabling the I²C Multimaster cell.</i></p>
3	BTF	<p><i>Byte transfer finished</i></p> <p>This bit is set by hardware as soon as a byte is correctly received or transmitted with interrupt generation if ITE = 1. It is cleared by software reading SR1 register followed by a read or write of DR register. It is also cleared by hardware when the interface is disabled (PE = 0).</p> <p>Following a byte transmission, this bit is set after reception of the acknowledge clock pulse. In case an address byte is sent, this bit is set only after the EV6 event (see Figure 68). BTF is cleared by reading SR1 register followed by writing the next byte in DR register.</p> <p>Following a byte reception, this bit is set after transmission of the acknowledge clock pulse if ACK = 1. BTF is cleared by reading SR1 register followed by reading the byte from DR register.</p> <p>The SCL line is held low while BTF = 1.</p> <p>0: Byte transfer not done 1: Byte transfer succeeded</p>
2	ADSL	<p><i>Address matched (Slave mode)</i></p> <p>This bit is set by hardware as soon as the received slave address matched with the OAR register content or a general call is recognized. An interrupt is generated if ITE = 1. It is cleared by software reading SR1 register or by hardware when the interface is disabled (PE = 0).</p> <p>The SCL line is held low while ADSL = 1.</p> <p>0: Address mismatched or not received 1: Received address matched</p>

Table 84. SR1 register description (continued)

Bit	Name	Function
1	M/SL	<p><i>Master/Slave</i></p> <p>This bit is set by hardware as soon as the interface is in Master mode (writing START = 1). It is cleared by hardware after detecting a Stop condition on the bus or a loss of arbitration (ARLO = 1). It is also cleared when the interface is disabled (PE = 0).</p> <p>0: Slave mode 1: Master mode</p>
0	SB	<p><i>Start bit (Master mode)</i></p> <p>This bit is set by hardware as soon as the Start condition is generated (following a write START = 1). An interrupt is generated if ITE = 1. It is cleared by software reading SR1 register followed by writing the address byte in DR register. It is also cleared by hardware when the interface is disabled (PE = 0).</p> <p>0: No Start condition 1: Start condition generated</p>

16.7.3 I²C status register 2 (SR2)

SR2		Reset value: 0000 0000 (00h)					
7	6	5	4	3	2	1	0
Reserved			AF	STOPF	ARLO	BERR	GCAL
			-	RO	RO	RO	RO

Table 85. SR2 register description

Bit	Name	Function
7:5	-	Reserved. Forced to 0 by hardware.
4	AF	<p><i>Acknowledge failure</i></p> <p>This bit is set by hardware when no acknowledge is returned. An interrupt is generated if ITE = 1. It is cleared by software reading SR2 register or by hardware when the interface is disabled (PE = 0).</p> <p>The SCL line is not held low while AF = 1 but by other flags (SB or BTF) that are set at the same time.</p> <p>0: No acknowledge failure 1: Acknowledge failure</p> <p><i>Note: When an AF event occurs, the SCL line is not held low; however, the SDA line can remain low if the last bits transmitted are all 0. It is then necessary to release both lines by software.</i></p>
3	STOPF	<p><i>Stop detection (Slave mode)</i></p> <p>This bit is set by hardware when a Stop condition is detected on the bus after an acknowledge (if ACK = 1). An interrupt is generated if ITE = 1. It is cleared by software reading SR2 register or by hardware when the interface is disabled (PE = 0).</p> <p>The SCL line is not held low while STOPF = 1.</p> <p>0: No Stop condition detected 1: Stop condition detected</p>

Table 85. SR2 register description (continued)

Bit	Name	Function
2	ARLO	<p><i>Arbitration lost</i></p> <p>This bit is set by hardware when the interface loses the arbitration of the bus to another master. An interrupt is generated if ITE = 1. It is cleared by software reading SR2 register or by hardware when the interface is disabled (PE = 0). After an ARLO event the interface switches back automatically to Slave mode (M/SL = 0). The SCL line is not held low while ARLO = 1.</p> <p>0: No arbitration lost detected 1: Arbitration lost detected</p> <p><i>Note: In a Multimaster environment, when the interface is configured in Master Receive mode it does not perform arbitration during the reception of the Acknowledge bit. Mishandling of the ARLO bit from the I2CSR2 register may occur when a second master simultaneously requests the same data from the same slave and the I²C master does not acknowledge the data. The ARLO bit is then left at 0 instead of being set.</i></p>
1	BERR	<p><i>Bus error</i></p> <p>This bit is set by hardware when the interface detects a misplaced Start or Stop condition. An interrupt is generated if ITE = 1. It is cleared by software reading SR2 register or by hardware when the interface is disabled (PE = 0). The SCL line is not held low while BERR = 1.</p> <p>0: No misplaced Start or Stop condition 1: Misplaced Start or Stop condition</p> <p><i>Note: If a Bus Error occurs, a Stop or a repeated Start condition should be generated by the Master to re-synchronize communication, get the transmission acknowledged and the bus released for further communication.</i></p>
0	GCAL	<p><i>General Call (Slave mode)</i></p> <p>This bit is set by hardware when a general call address is detected on the bus while ENGC = 1. It is cleared by hardware detecting a Stop condition (STOPF = 1) or when the interface is disabled (PE = 0).</p> <p>0: No general call address detected on bus 1: General call address detected on bus</p>

16.7.4 I²C clock control register (CCR)

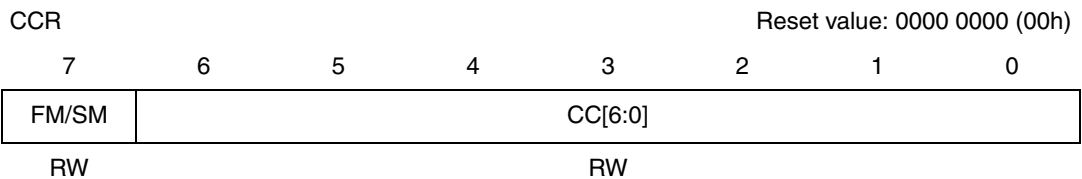

Table 86. CCR register description

Bit	Name	Function
7	FM/SM	<p><i>Fast/Standard I²C mode</i></p> <p>This bit is set and cleared by software. It is not cleared when the interface is disabled (PE = 0).</p> <p>0: Standard I²C mode 1: Fast I²C mode</p>

Table 86. CCR register description (continued)

Bit	Name	Function
6:0	CC[6:0]	<p><i>7-bit clock divider</i></p> <p>These bits select the speed of the bus (f_{SCL}) depending on the I²C mode. They are not cleared when the interface is disabled (PE = 0). Refer to Section 19: Electrical characteristics for the table of values.</p> <p><i>Note: The programmed f_{SCL} assumes no load on SCL and SDA lines.</i></p>

16.7.5 I²C data register (DR)

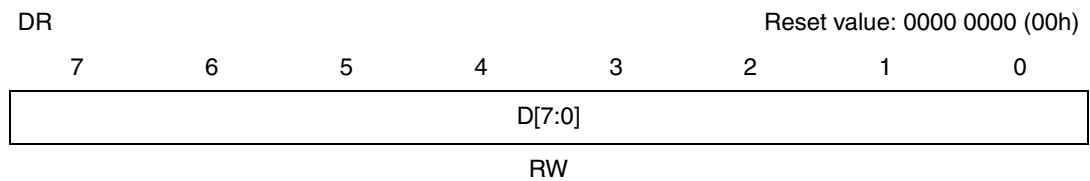

Table 87. DR register description

Bit	Name	Function
7:0	D[7:0]	<p><i>8-bit Data Register</i></p> <p>These bits contain the byte to be received or transmitted on the bus.</p> <p>Transmitter mode: Byte transmission start automatically when the software writes in the DR register.</p> <p>Receiver mode: The first data byte is received automatically in the DR register using the least significant bit of the address. Then, the following data bytes are received one by one after reading the DR register.</p>

16.7.6 I²C own address register (OAR1)

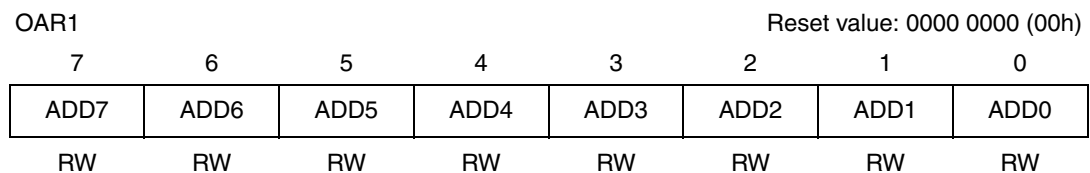

Table 88. OAR1 register description

Bit	Name	Function	
		7-bit addressing mode	10-bit addressing mode
7:1	ADD[7:1]	<i>Interface address</i> These bits define the I ² C bus address of the interface. They are not cleared when the interface is disabled (PE = 0).	
0	ADD0		
7:0	ADD[7:0]	Not applicable	<i>Interface address</i> These are the least significant bits of the I ² C bus address of the interface. They are not cleared when the interface is disabled (PE = 0).

16.7.7 I²C own address register (OAR2)

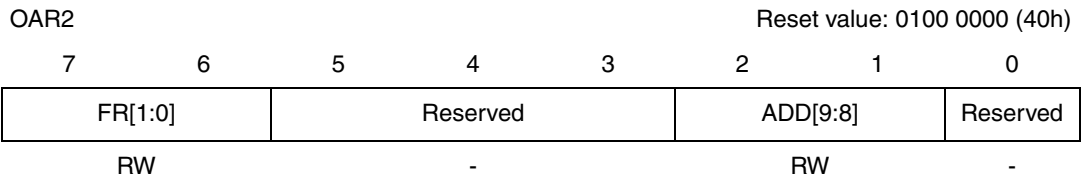

Table 89. OAR2 register description

Bit	Name	Function
7:6	FR[1:0]	<i>Frequency bits</i> These bits are set by software only when the interface is disabled (PE = 0). To configure the interface to I ² C specified delays, select the value corresponding to the CPU frequency f_{CPU} . 00: $f_{CPU} < 6$ MHz 01: $f_{CPU} = 6$ to 8 MHz
5:3	-	Reserved
2:1	ADD[9:8]	<i>Interface address</i> These are the most significant bits of the I ² C bus address of the interface (10-bit mode only). They are not cleared when the interface is disabled (PE = 0).
0	-	Reserved

Table 90. I²C register map and reset values

Address (Hex.)	Register label	7	6	5	4	3	2	1	0
0018h	I2CCR Reset value	0	0	PE 0	ENG 0	START 0	ACK 0	STOP 0	ITE 0
0019h	I2CSR1 Reset value	EVF 0	ADD10 0	TRA 0	BUSY 0	BTF 0	ADSL 0	M/SL 0	SB 0
001Ah	I2CSR2 Reset value	0	0	0	AF 0	STOPF 0	ARLO 0	BERR 0	GCAL 0
001Bh	I2CCCR Reset value	FM/SM 0	CC6 0	CC5 0	CC4 0	CC3 0	CC2 0	CC1 0	CC0 0
001Ch	I2COAR1 Reset value	ADD7 0	ADD6 0	ADD5 0	ADD4 0	ADD3 0	ADD2 0	ADD1 0	ADD0 0
001Dh	I2COAR2 Reset value	FR1 0	FR0 1	0	0	0	ADD9 0	ADD8 0	0
001Eh	I2CDR Reset value	MSB 0	0	0	0	0	0	0	LSB 0

17 10-bit A/D converter (ADC)

17.1 Introduction

The on-chip Analog to Digital Converter (ADC) peripheral is a 10-bit, successive approximation converter with internal sample and hold circuitry. This peripheral has up to 16 multiplexed analog input channels (refer to device pin out description) that allow the peripheral to convert the analog voltage levels from up to 16 different sources.

The result of the conversion is stored in a 10-bit data register. The A/D converter is controlled through a control/status register.

17.2 Main features

- 10-bit conversion
- Up to 16 channels with multiplexed input
- Linear successive approximation
- Data register (DR) which contains the results
- Conversion complete status flag
- On/off bit (to reduce consumption)

The block diagram is shown in [Figure 70](#).

Figure 70. ADC block diagram

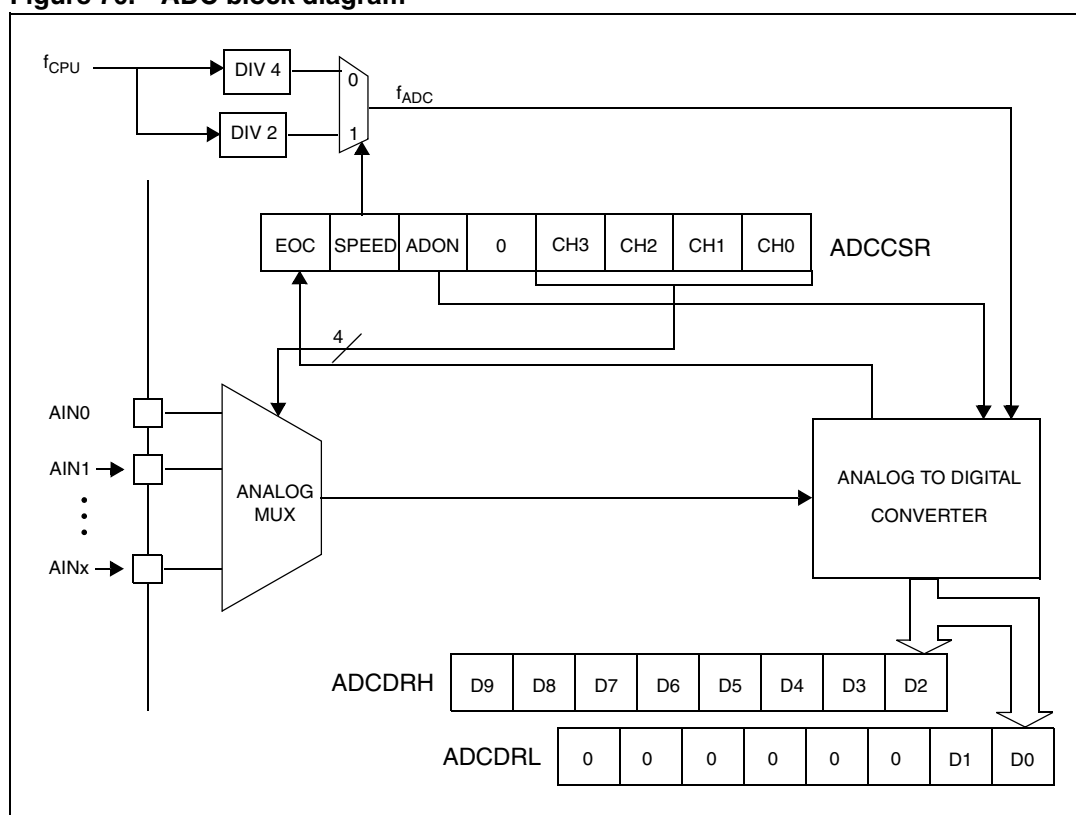

17.3 Functional description

The conversion is monotonic, meaning that the result never decreases if the analog input does not and never increases if the analog input does not.

If the input voltage (V_{AIN}) is greater than V_{AREF} (high-level voltage reference) then the conversion result is FFh in the ADCDRH register and 03h in the ADCDRL register (without overflow indication).

If the input voltage (V_{AIN}) is lower than V_{SSA} (low-level voltage reference) then the conversion result in the ADCDRH and ADCDRL registers is 00 00h.

The A/D converter is linear and the digital result of the conversion is stored in the ADCDRH and ADCDRL registers. The accuracy of the conversion is described in [Section 19: Electrical characteristics](#).

R_{AIN} is the maximum recommended impedance for an analog input signal. If the impedance is too high, this will result in a loss of accuracy due to leakage and sampling not being completed in the allotted time.

17.3.1 A/D converter configuration

The analog input ports must be configured as input, no pull-up, no interrupt. Refer to the [Chapter 9: I/O ports](#). Using these pins as analog inputs does not affect the ability of the port to be read as a logic input.

In the ADCCSR register:

- Select the CS[3:0] bits to assign the analog channel to convert.

17.3.2 Starting the conversion

In the ADCCSR register:

- Set the ADON bit to enable the A/D converter and to start the conversion. From this time on, the ADC performs a continuous conversion of the selected channel.

When a conversion is complete:

- The EOC bit is set by hardware.
- The result is in the ADCDR registers.

A read to the ADCDRH or a write to any bit of the ADCCSR register resets the EOC bit.

To read the 10 bits, perform the following steps:

1. Poll the EOC bit.
2. Read the ADCDRL register.
3. Read the ADCDRH register. This clears EOC automatically.

Note: The data is not latched, so both the low and the high data register must be read before the next conversion is complete, so it is recommended to disable interrupts while reading the conversion result.

To read only 8 bits, perform the following steps:

1. Poll the EOC bit.
2. Read the ADCDRH register. This clears EOC automatically.

17.3.3 Changing the conversion channel

The application can change channels during conversion. When software modifies the CH[3:0] bits in the ADCCSR register, the current conversion is stopped, the EOC bit is cleared, and the A/D converter starts converting the newly selected channel.

17.4 Low power modes

Note: The A/D converter may be disabled by resetting the ADON bit. This feature allows reduced power consumption when no conversion is needed and between single shot conversions.

Table 91. Effect of low power modes on ADC

Mode	Effect
Wait	No effect on A/D converter
Halt	A/D converter disabled. After wake-up from Halt mode, the A/D converter requires a stabilization time t_{STAB} (see Section 19: Electrical characteristics) before accurate conversions can be performed.

17.5 Interrupts

None.

17.6 ADC registers

17.6.1 Control/status register (ADCCSR)

ADCCSR					Reset value: 0000 0000 (00h)		
7	6	5	4	3	2	1	0
EOC	SPEED	ADON	Reserved	CH[3:0]			
RO	RW	RW	-	RW			

Table 92. ADCCSR register description

Bit	Name	Function
7	EOC	<i>End of Conversion</i> This bit is set by hardware. It is cleared by hardware when software reads the ADCDRH register or writes to any bit of the ADCCSR register. 0: Conversion is not complete 1: Conversion complete
6	SPEED	<i>ADC clock selection</i> This bit is set and cleared by software. 0: $f_{ADC} = f_{CPU}/4$ 1: $f_{ADC} = f_{CPU}/2$

Table 92. ADCCSR register description (continued)

Bit	Name	Function
5	ADON	<i>A/D Converter on</i> This bit is set and cleared by software. 0: Disable ADC and stop conversion 1: Enable ADC and start conversion
4	-	Reserved. Must be kept cleared
3:0	CH[3:0]	<i>Channel Selection</i> These bits are set and cleared by software. They select the analog input to convert. 0000: Channel pin = AIN0 0001: Channel pin = AIN1 0010: Channel pin = AIN2 0011: Channel pin = AIN3 0100: Channel pin = AIN4 0101: Channel pin = AIN5 0110: Channel pin = AIN6 0111: Channel pin = AIN7 1000: Channel pin = AIN8 1001: Channel pin = AIN9 1010: Channel pin = AIN10 1011: Channel pin = AIN11 1100: Channel pin = AIN12 1101: Channel pin = AIN13 1110: Channel pin = AIN14 1111: Channel pin = AIN15 <i>Note: The number of channels is device dependent. Refer to the device pinout description.</i>

17.6.2 Data register (ADCDRH)

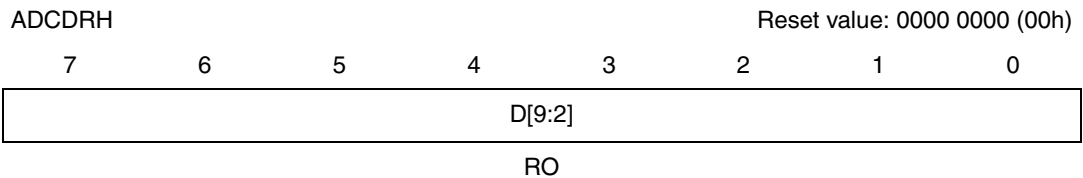

Table 93. ADCDRH register description

Bit	Name	Function
7:0	D[9:2]	<i>MSB of Converted Analog Value</i>

17.6.3 Data register (ADCDRL)

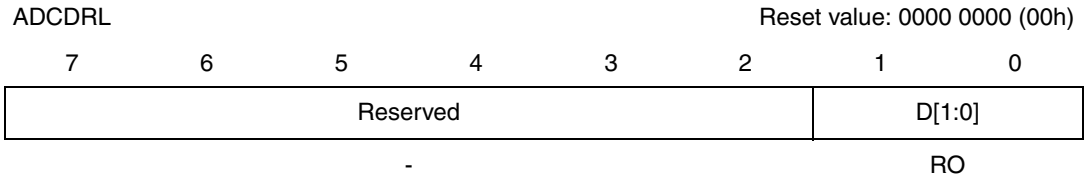

Table 94. ADCDRL register description

Bit	Name	Function
7:2	-	Reserved. Forced by hardware to 0.
1:0	D[1:0]	LSB of Converted Analog Value

17.6.4 ADC register map and reset values

Table 95. ADC register map and reset values

Address (Hex.)	Register label	7	6	5	4	3	2	1	0
0070h	ADCCSR Reset value	EOC 0	SPEED 0	ADON 0	0	CH3 0	CH2 0	CH1 0	CH0 0
0071h	ADCDRH Reset value	D9 0	D8 0	D7 0	D6 0	D5 0	D4 0	D3 0	D2 0
0072h	ADCDRL Reset value	0	0	0	0	0	0	D1 0	D0 0

18 Instruction set

18.1 CPU addressing modes

The CPU features 17 different addressing modes which can be classified in seven main groups as listed in the following table:

Table 96. Addressing modes

Group	Example
Inherent	NOP
Immediate	LD A,#\$55
Direct	LD A,\$55
Indexed	LD A,(\$55,X)
Indirect	LD A,([\$55],X)
Relative	JRNE loop
Bit operation	BSET byte,#5

The CPU instruction set is designed to minimize the number of bytes required per instruction: To do so, most of the addressing modes may be divided in two submodes called long and short:

- Long addressing mode is more powerful because it can use the full 64 Kbyte address space; however, it uses more bytes and more CPU cycles.
- Short addressing mode is less powerful because it can generally only access page zero (0000h - 00FFh range), but the instruction size is more compact, and faster. All memory to memory instructions use short addressing modes only (CLR, CPL, NEG, BSET, BRES, BTJT, BTJF, INC, DEC, RLC, RRC, SLL, SRL, SRA, SWAP).

The ST7 Assembler optimizes the use of long and short addressing modes.

Table 97. CPU addressing mode overview

Mode		Syntax	Destination	Pointer address (Hex.)	Pointer size (Hex.)	Length (bytes)
Inherent		nop				+ 0
Immediate		ld A,#\$55				+ 1
Short	Direct	ld A,\$10	00..FF			+ 1
Long	Direct	ld A,\$1000	0000..FFFF			+ 2
No Offset	Direct Indexed	ld A,(X)	00..FF			+ 0
Short	Direct Indexed	ld A,(\$10,X)	00..1FE			+ 1
Long	Direct Indexed	ld A,(\$1000,X)	0000..FFFF			+ 2
Short	Indirect	ld A,[\$10]	00..FF	00..FF	byte	+ 2
Long	Indirect	ld A,[\$10.w]	0000..FFFF	00..FF	word	+ 2
Short	Indirect Indexed	ld A,([\$10],X)	00..1FE	00..FF	byte	+ 2

Table 97. CPU addressing mode overview (continued)

Mode			Syntax	Destination	Pointer address (Hex.)	Pointer size (Hex.)	Length (bytes)
Long	Indirect	Indexed	ld A, ([\$10.w],X)	0000..FFFF	00..FF	word	+ 2
Relative	Direct		jrne loop	PC+/-127			+ 1
Relative	Indirect		jrne [\$10]	PC+/-127	00..FF	byte	+ 2
Bit	Direct		bset \$10,#7	00..FF			+ 1
Bit	Indirect		bset [\$10],#7	00..FF	00..FF	byte	+ 2
Bit	Direct	Relative	btjt \$10,#7,skip	00..FF			+ 2
Bit	Indirect	Relative	btjt [\$10],#7,skip	00..FF	00..FF	byte	+ 3

18.1.1 Inherent

All Inherent instructions consist of a single byte. The opcode fully specifies all the required information for the CPU to process the operation.

Table 98. Inherent instructions

Instruction	Function
NOP	No operation
TRAP	S/W Interrupt
WFI	Wait For Interrupt (Low Power Mode)
HALT	Halt Oscillator (Lowest Power Mode)
RET	Sub-routine Return
IRET	Interrupt Sub-routine Return
SIM	Set Interrupt Mask (level 3)
RIM	Reset Interrupt Mask (level 0)
SCF	Set Carry Flag
RCF	Reset Carry Flag
RSP	Reset Stack Pointer
LD	Load
CLR	Clear
PUSH/POP	Push/Pop to/from the stack
INC/DEC	Increment/Decrement
TNZ	Test Negative or Zero
CPL, NEG	1 or 2 Complement
MUL	Byte Multiplication
SLL, SRL, SRA, RLC, RRC	Shift and Rotate Operations
SWAP	Swap Nibbles

18.1.2 Immediate

Immediate instructions have 2 bytes. The first byte contains the opcode and the second byte contains the operand value.

Table 99. Immediate instructions

Instruction	Function
LD	Load
CP	Compare
BCP	Bit Compare
AND, OR, XOR	Logical Operations
ADC, ADD, SUB, SBC	Arithmetic Operations

18.1.3 Direct

In Direct instructions, the operands are referenced by their memory address.

The direct addressing mode consists of two submodes:

Direct (short)

The address is a byte, thus requires only one byte after the opcode, but only allows 00 - FF addressing space.

Direct (long)

The address is a word, thus allowing 64 Kbyte addressing space, but requires 2 bytes after the opcode.

18.1.4 Indexed (no offset, short, long)

In this mode, the operand is referenced by its memory address, which is defined by the unsigned addition of an index register (X or Y) with an offset.

The indexed addressing mode consists of three submodes:

Indexed (no offset)

There is no offset, (no extra byte after the opcode), and allows 00 - FF addressing space.

Indexed (short)

The offset is a byte, thus requires only one byte after the opcode and allows 00 - 1FE addressing space.

Indexed (long)

The offset is a word, thus allowing 64 Kbyte addressing space and requires 2 bytes after the opcode.

18.1.5 Indirect (short, long)

The required data byte to do the operation is found by its memory address, located in memory (pointer).

The pointer address follows the opcode. The indirect addressing mode consists of two submodes:

Indirect (short)

The pointer address is a byte, the pointer size is a byte, thus allowing 00 - FF addressing space, and requires 1 byte after the opcode.

Indirect (long)

The pointer address is a byte, the pointer size is a word, thus allowing 64 Kbyte addressing space, and requires 1 byte after the opcode.

18.1.6 Indirect indexed (short, long)

This is a combination of indirect and short indexed addressing modes. The operand is referenced by its memory address, which is defined by the unsigned addition of an index register value (X or Y) with a pointer value located in memory. The pointer address follows the opcode.

The indirect indexed addressing mode consists of two submodes:

Indirect indexed (short)

The pointer address is a byte, the pointer size is a byte, thus allowing 00 - 1FE addressing space, and requires 1 byte after the opcode.

Indirect indexed (long)

The pointer address is a byte, the pointer size is a word, thus allowing 64 Kbyte addressing space, and requires 1 byte after the opcode.

Table 100. Instructions supporting direct, indexed, indirect, and indirect indexed addressing modes

Type	Instruction	Function
Long and short instructions	LD	Load
	CP	Compare
	AND, OR, XOR	Logical operations
	ADC, ADD, SUB, SBC	Arithmetic Additions/Subtractions operations
	BCP	Bit Compare

Table 100. Instructions supporting direct, indexed, indirect, and indirect indexed addressing modes (continued)

Type	Instruction	Function
Short instructions only	CLR	Clear
	INC, DEC	Increment/Decrement
	TNZ	Test Negative or Zero
	CPL, NEG	1 or 2 Complement
	BSET, BRES	Bit Operations
	BTJT, BTJF	Bit Test and Jump Operations
	SLL, SRL, SRA, RLC, RRC	Shift and Rotate Operations
	SWAP	Swap Nibbles
	CALL, JP	Call or Jump subroutine

18.1.7 Relative (direct, indirect)

This addressing mode is used to modify the PC register value, by adding an 8-bit signed offset to it.

Table 101. Available relative direct/indirect instructions

Instruction	Function
JRxx	Conditional Jump
CALLR	Call Relative

The relative addressing mode consists of two submodes:

Relative (direct)

The offset is following the opcode.

Relative (indirect)

The offset is defined in memory, which address follows the opcode.

18.2 Instruction groups

The ST7 family devices use an Instruction Set consisting of 63 instructions. The instructions may be subdivided into 13 main groups as illustrated in the following table:

Table 102. Instruction groups

Group	Instructions							
Load and Transfer	LD	CLR						
Stack operation	PUSH	POP	RSP					
Increment/Decrement	INC	DEC						
Compare and Tests	CP	TNZ	BCP					

Table 102. Instruction groups (continued)

Group	Instructions							
Logical operations	AND	OR	XOR	CPL	NEG			
Bit Operation	BSET	BRES						
Conditional Bit Test and Branch	BTJT	BTJF						
Arithmetic operations	ADC	ADD	SUB	SBC	MUL			
Shift and Rotates	SLL	SRL	SRA	RLC	RRC	SWAP	SLA	
Unconditional Jump or Call	JRA	JRT	JRF	JP	CALL	CALLR	NOP	RET
Conditional Branch	JRxx							
Interruption management	TRAP	WFI	HALT	IRET				
Condition Code Flag modification	SIM	RIM	SCF	RCF				

18.2.1 Using a prebyte

The instructions are described with one to four opcodes.

In order to extend the number of available opcodes for an 8-bit CPU (256 opcodes), three different prebyte opcodes are defined. These prebytes modify the meaning of the instruction they precede.

The whole instruction becomes:

- PC - 2 End of previous instruction
- PC - 1 Prebyte
- PC Opcode
- PC + 1 Additional word (0 to 2) according to the number of bytes required to compute the effective address

These prebytes enable instruction in Y as well as indirect addressing modes to be implemented. They precede the opcode of the instruction in X or the instruction using direct addressing mode. The prebytes are:

- PDY 90 Replace an X based instruction using immediate, direct, indexed, or inherent addressing mode by a Y one.
- PIX 92 Replace an instruction using direct, direct bit, or direct relative addressing mode to an instruction using the corresponding indirect addressing mode.
It also changes an instruction using X indexed addressing mode to an instruction using indirect X indexed addressing mode.
- PIY 91 Replace an instruction using X indirect indexed addressing mode by a Y one.

Table 103. Instruction set overview

Mnemo	Description	Function/Example	Dst	Src	I1	H	I0	N	Z	C
ADC	Add with Carry	$A = A + M + C$	A	M		H		N	Z	C
ADD	Addition	$A = A + M$	A	M		H		N	Z	C
AND	Logical And	$A = A . M$	A	M				N	Z	
BCP	Bit compare A, Memory	tst (A . M)	A	M				N	Z	
BRES	Bit Reset	bres Byte, #3	M							
BSET	Bit Set	bset Byte, #3	M							
BTJF	Jump if bit is false (0)	btjf Byte, #3, Jmp1	M							C
BTJT	Jump if bit is true (1)	btjt Byte, #3, Jmp1	M							C
CALL	Call subroutine									
CALLR	Call subroutine relative									
CLR	Clear		reg, M					0	1	
CP	Arithmetic Compare	tst(Reg - M)	reg	M				N	Z	C
CPL	One Complement	$A = FFH-A$	reg, M					N	Z	1
DEC	Decrement	dec Y	reg, M					N	Z	
HALT	Halt				1		0			
IRET	Interrupt routine return	Pop CC, A, X, PC			I1	H	I0	N	Z	C
INC	Increment	inc X	reg, M					N	Z	
JP	Absolute Jump	jp [TBL.w]								
JRA	Jump relative always									
JRT	Jump relative									
JRF	Never jump	jrf *								
JRIH	Jump if ext. INT pin = 1	(ext. INT pin high)								
JRIL	Jump if ext. INT pin = 0	(ext. INT pin low)								
JRH	Jump if H = 1	H = 1 ?								
JRNH	Jump if H = 0	H = 0 ?								
JRM	Jump if I1:0 = 11	I1:0 = 11 ?								
JRNM	Jump if I1:0 <> 11	I1:0 <> 11 ?								
JRMI	Jump if N = 1 (minus)	N = 1 ?								
JRPL	Jump if N = 0 (plus)	N = 0 ?								
JREQ	Jump if Z = 1 (equal)	Z = 1 ?								
JRNE	Jump if Z = 0 (not equal)	Z = 0 ?								
JRC	Jump if C = 1	C = 1 ?								
JRNC	Jump if C = 0	C = 0 ?								
JRULT	Jump if C = 1	Unsigned <								
JRUGE	Jump if C = 0	Jmp if unsigned >=								

Table 103. Instruction set overview (continued)

Mnemo	Description	Function/Example	Dst	Src	I1	H	I0	N	Z	C
JRUGT	Jump if (C + Z = 0)	Unsigned >								
JRULE	Jump if (C + Z = 1)	Unsigned <=								
LD	Load	dst <= src	reg, M	M, reg				N	Z	
MUL	Multiply	X,A = X * A	A, X, Y	X, Y, A		0				0
NEG	Negate (2's compl)	neg \$10	reg, M					N	Z	C
NOP	No Operation									
OR	OR operation	A = A + M	A	M				N	Z	
POP	Pop from the Stack	pop reg	reg	M						
		pop CC	CC	M	I1	H	I0	N	Z	C
PUSH	Push onto the Stack	push Y	M	reg, CC						
RCF	Reset carry flag	C = 0								0
RET	Subroutine Return									
RIM	Enable Interrupts	I1:0 = 10 (level 0)			1		0			
RLC	Rotate left true C	C <= A <= C	reg, M					N	Z	C
RRC	Rotate right true C	C => A => C	reg, M					N	Z	C
RSP	Reset Stack Pointer	S = Max allowed								
SBC	Subtract with Carry	A = A - M - C	A	M				N	Z	C
SCF	Set carry flag	C = 1								1
SIM	Disable Interrupts	I1:0 = 11 (level 3)			1		1			
SLA	Shift left Arithmetic	C <= A <= 0	reg, M					N	Z	C
SLL	Shift left Logic	C <= A <= 0	reg, M					N	Z	C
SRL	Shift right Logic	0 => A => C	reg, M				0	Z	C	
SRA	Shift right Arithmetic	A7 => A => C	reg, M					N	Z	C
SUB	Subtraction	A = A - M	A	M				N	Z	C
SWAP	SWAP nibbles	A7-A4 <=> A3-A0	reg, M					N	Z	
TNZ	Test for Neg & Zero	tnz lbl1						N	Z	
TRAP	S/W trap	S/W interrupt			1		1			
WFI	Wait for Interrupt				1		0			
XOR	Exclusive OR	A = A XOR M	A	M				N	Z	

19 Electrical characteristics

19.1 Parameter conditions

Unless otherwise specified, all voltages are referred to V_{SS} .

19.1.1 Minimum and maximum values

Unless otherwise specified the minimum and maximum values are guaranteed in the worst conditions of ambient temperature, supply voltage and frequencies by tests in production on 100% of the devices with an ambient temperature at $T_A = 25^\circ\text{C}$ and $T_A = T_{Amax}$ (given by the selected temperature range).

Data based on characterization results, design simulation and/or technology characteristics are indicated in the table footnotes and are not tested in production. Based on characterization, the minimum and maximum values refer to sample tests and represent the mean value plus or minus three times the standard deviation (mean $\pm 3\Sigma$).

19.1.2 Typical values

Unless otherwise specified, typical data is based on $T_A = 25^\circ\text{C}$, $V_{DD} = 5\text{V}$. The typical values are given only as design guidelines and are not tested.

19.1.3 Typical curves

Unless otherwise specified, all typical curves are given only as design guidelines and are not tested.

19.1.4 Loading capacitor

The loading conditions used for pin parameter measurement are shown in [Figure 71](#).

Figure 71. Pin loading conditions

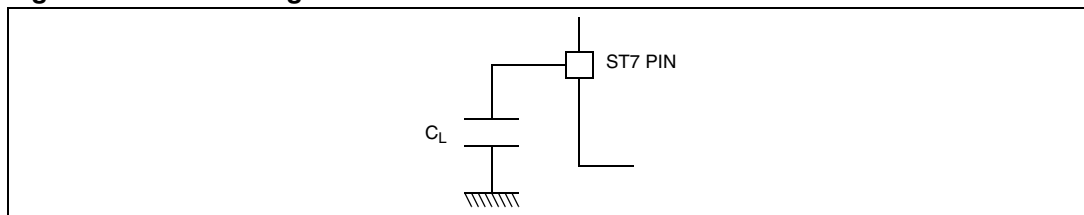

19.1.5 Pin input voltage

The input voltage measurement on a pin of the device is described in [Figure 72](#).

Figure 72. Pin input voltage

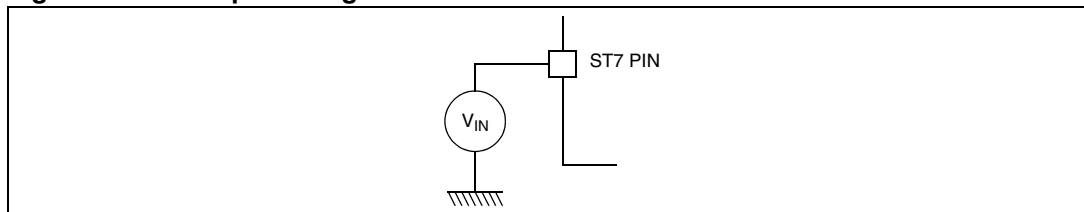

19.2 Absolute maximum ratings

Stresses above those listed as “absolute maximum ratings” may cause permanent damage to the device. This is a stress rating only and functional operation of the device under these conditions is not implied. Exposure to maximum rating conditions for extended periods may affect device reliability.

19.2.1 Voltage characteristics

Table 104. Voltage characteristics

Symbol	Ratings	Maximum value	Unit
$V_{DD} - V_{SS}$	Supply voltage	6.5	V
$V_{PP} - V_{SS}$	Programming voltage	13	
$V_{IN}^{(1)}$	Input voltage on true open-drain pin	$V_{SS} - 0.3$ to 6.5	
	Input voltage on any other pin	$V_{SS} - 0.3$ to $V_{DD} + 0.3$	
$ \Delta V_{DDx} $ and $ \Delta V_{SSx} $	Variations between different digital power pins	50	mV
$ V_{SSA} - V_{SSx} $	Variations between digital and analog ground pins	50	
$V_{ESD(HBM)}$	Electrostatic discharge voltage (Human Body Model)	See Section 19.7.3 on page 202 .	
$V_{ESD(MM)}$	Electrostatic discharge voltage (Machine Model)		

1. Directly connecting the \overline{RESET} and I/O pins to V_{DD} or V_{SS} could damage the device if an unintentional internal reset is generated or an unexpected change of the I/O configuration occurs (for example, due to a corrupted program counter). To guarantee safe operation, this connection has to be done through a pull-up or pull-down resistor (typical: $4.7k\Omega$ for \overline{RESET} , $10k\Omega$ for I/Os). For the same reason, unused I/O pins must not be directly tied to V_{DD} or V_{SS} .

19.2.2 Current characteristics

Table 105. Current characteristics

Symbol	Ratings	Maximum value	Unit
I_{VDD}	Total current into V_{DD} power lines (source) ⁽¹⁾	150	mA
I_{VSS}	Total current out of V_{SS} ground lines (sink) ⁽¹⁾		
I_{IO} ⁽²⁾	Output current sunk by any standard I/O and control pin	25	mA
	Output current sunk by any high sink I/O pin	50	
	Output current source by any I/Os and control pin	- 25	
$I_{INJ(PIN)}$ ⁽³⁾⁽⁴⁾	Injected current on V_{PP} pin	± 5	
	Injected current on \overline{RESET} pin	± 5	
	Injected current on OSC1 and OSC2 pins	± 5	
	Injected current on PC6 pin (Flash devices only)	+ 5	
	Injected current on any other pin ⁽⁵⁾⁽⁶⁾	± 5	
$\Sigma I_{INJ(PIN)}$ ⁽³⁾	Total injected current (sum of all I/O and control pins) ⁽⁵⁾	± 25	

- All power (V_{DD}) and ground (V_{SS}) lines must always be connected to the external supply.
- Directly connecting the \overline{RESET} and I/O pins to V_{DD} or V_{SS} could damage the device if an unintentional internal reset is generated or an unexpected change of the I/O configuration occurs (for example, due to a corrupted program counter). To guarantee safe operation, this connection has to be done through a pull-up or pull-down resistor (typical: 4.7k Ω for \overline{RESET} , 10k Ω for I/Os). For the same reason, unused I/O pins must not be directly tied to V_{DD} or V_{SS} .
- $I_{INJ(PIN)}$ must never be exceeded. This is implicitly ensured if V_{IN} maximum is respected. If V_{IN} maximum cannot be respected, the injection current must be limited externally to the $I_{INJ(PIN)}$ value. A positive injection is induced by $V_{IN} > V_{DD}$ while a negative injection is induced by $V_{IN} < V_{SS}$. For true open-drain pads, there is no positive injection current, and the corresponding V_{IN} maximum must always be respected.
- Negative injection may disturb the analog performance of the device. See [Note 1](#) in [Table 136: ADC accuracy on page 219](#).
- When several inputs are submitted to a current injection, the maximum $\Sigma I_{INJ(PIN)}$ is the absolute sum of the positive and negative injected currents (instantaneous values). These results are based on characterization with $\Sigma I_{INJ(PIN)}$ maximum current injection on four I/O port pins of the device.
- True open-drain I/O port pins do not accept positive injection.

19.2.3 Thermal characteristics

Table 106. Thermal characteristics

Symbol	Ratings	Value	Unit
T_{STG}	Storage temperature range	-65 to +150	$^{\circ}\text{C}$
T_J	Maximum junction temperature (see Section 20.1: Thermal characteristics on page 222)		

19.3 Operating conditions

19.3.1 General operating conditions

Table 107. General operating conditions

Symbol	Parameter	Conditions	Min	Max	Unit
f _{CPU}	Internal clock frequency		0	8	MHz
V _{DD}	Standard voltage range (except Flash Write/Erase)		3.8	5.5	V
	Operating voltage for Flash Write/Erase	V _{PP} = 11.4 to 12.6V	4.5	5.5	
T _A	Ambient temperature range	A suffix version	-40	85	°C
		B suffix version		105	
		C suffix version		125	

Note: Some temperature ranges are only available with a specific package and memory size. Refer to [Section 21: Device configuration and ordering information on page 223](#).

Figure 73. f_{CPU} max versus V_{DD}

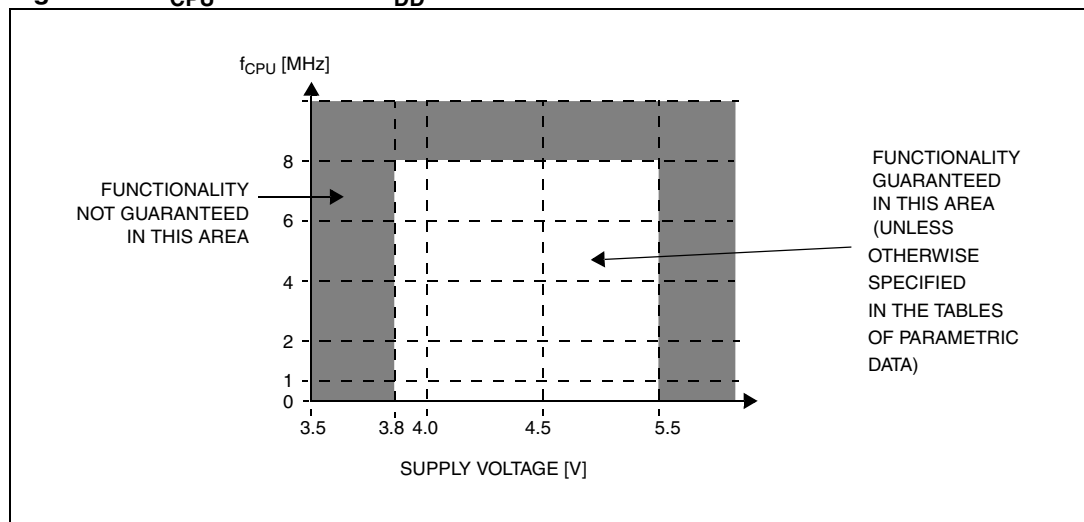

19.3.2 Operating conditions with low voltage detector (LVD)

Subject to general operating conditions for V_{DD} , f_{CPU} , and T_A .

Table 108. Operating conditions with low voltage detector (LVD)

Symbol	Parameter	Conditions	Min	Typ	Max	Unit
$V_{IT+(LVD)}$	Reset release threshold (V_{DD} rise)	VD level = High in option byte	4.0 ⁽¹⁾	4.2	4.5	V
		VD level = Med. in option byte ⁽²⁾	3.55 ⁽¹⁾	3.75	4.0 ⁽¹⁾	
		VD level = Low in option byte ⁽²⁾	2.95 ⁽¹⁾	3.15	3.35 ⁽¹⁾	
$V_{IT-(LVD)}$	Reset generation threshold (V_{DD} fall)	VD level = High in option byte	3.8	4.0	4.25 ⁽¹⁾	V
		VD level = Med. in option byte ⁽²⁾	3.35 ⁽¹⁾	3.55	3.75 ⁽¹⁾	
		VD level = Low in option byte ⁽²⁾	2.8 ⁽¹⁾	3.0	3.15 ⁽¹⁾	
$V_{hys(LVD)}$	LVD voltage threshold hysteresis	$V_{IT+(LVD)} - V_{IT-(LVD)}$		200		mV
V_{tPOR}	V_{DD} rise time ⁽²⁾⁽³⁾	LVD enabled	6 μ s/V		100ms/V	-
$t_{g(VDD)}$	V_{DD} glitches filtered (not detected) by LVD ⁽⁴⁾				40	ns

1. Data based on characterization results, tested in production for ROM devices only
2. Data based on characterization results, not tested in production
3. When V_{tPOR} is faster than 100 μ s/V, the Reset signal is released after a delay of maximum 42 μ s after V_{DD} crosses the $V_{IT+(LVD)}$ threshold.
4. If the medium or low thresholds are selected, the detection may occur outside the specified operating voltage range. Below 3.8V, device operation is not guaranteed.

19.3.3 Auxiliary voltage detector (AVD) thresholds

Subject to general operating conditions for V_{DD} , f_{CPU} , and T_A .

Table 109. Auxiliary voltage detector (AVD) thresholds

Symbol	Parameter	Conditions	Min	Typ	Max	Unit
$V_{IT+(AVD)}$	1 \Rightarrow 0 AVDF flag toggle threshold (V_{DD} rise)	VD level = High in option byte	4.4 ⁽¹⁾	4.6	4.9 ⁽¹⁾	V
		VD level = Med. in option byte	3.95 ⁽¹⁾	4.15	4.4 ⁽¹⁾	
		VD level = Low in option byte	3.4 ⁽¹⁾	3.6	3.8 ⁽¹⁾	
$V_{IT-(AVD)}$	0 \Rightarrow 1 AVDF flag toggle threshold (V_{DD} fall)	VD level = High in option byte	4.2 ⁽¹⁾	4.4	4.65 ⁽¹⁾	V
		VD level = Med. in option byte	3.75 ⁽¹⁾	4.0	4.2 ⁽¹⁾	
		VD level = Low in option byte	3.2 ⁽¹⁾	3.4	3.6 ⁽¹⁾	
$V_{hys(AVD)}$	AVD voltage threshold hysteresis	$V_{IT+(AVD)} - V_{IT-(AVD)}$		200		mV
ΔV_{IT-}	Voltage drop between AVD flag set and LVD reset activated	$V_{IT-(AVD)} - V_{IT-(LVD)}$		450		

1. Data based on characterization results, tested in production for ROM devices only

19.3.4 External voltage detector (EVD) thresholds

Subject to general operating conditions for V_{DD} , f_{CPU} , and T_A .

Table 110. External voltage detector (EVD) thresholds

Symbol	Parameter	Conditions	Min	Typ	Max	Unit
$V_{IT+(EVD)}$	1 \Rightarrow 0 AVDF flag toggle threshold (V_{DD} rise) ⁽¹⁾		1.15	1.26	1.35	V
$V_{IT-(EVD)}$	0 \Rightarrow 1 AVDF flag toggle threshold (V_{DD} fall) ⁽¹⁾		1.1	1.2	1.3	
$V_{hys(EVD)}$	EVD voltage threshold hysteresis	$V_{IT+(EVD)} - V_{IT-(EVD)}$		200		mV

1. Data based on characterization results, not tested in production

19.4 Supply current characteristics

The following current consumption specified for the ST7 functional operating modes over temperature range does not take into account the clock source current consumption. To obtain the total device consumption, the two current values must be added (except for Halt mode, for which the clock is stopped).

19.4.1 Current consumption

Table 111. Current consumption

Symbol	Parameter	Conditions	Flash devices		ROM devices		Unit
			Typ	Max ⁽¹⁾	Typ	Max ⁽¹⁾	
I _{DD}	Supply current in Run mode ⁽²⁾	f _{OSC} = 2MHz, f _{CPU} = 1 MHz	1.3	3.0	1.3	2.0	mA
		f _{OSC} = 4 MHz, f _{CPU} = 2 MHz	2.0	5.0	2.0	3.0	
		f _{OSC} = 8 MHz, f _{CPU} = 4 MHz	3.6	8.0	3.6	5.0	
		f _{OSC} = 16 MHz, f _{CPU} = 8 MHz	7.1	15.0	7.1	10.0	
	Supply current in Slow mode ⁽²⁾	f _{OSC} = 2 MHz, f _{CPU} = 62.5 kHz	600	2700	600	1800	μA
f _{OSC} = 4 MHz, f _{CPU} = 125 kHz		700	3000	700	2100		
f _{OSC} = 8 MHz, f _{CPU} = 250 kHz		800	3600	800	2400		
f _{OSC} = 16 MHz, f _{CPU} = 500 kHz		1100	4000	1100	3000		
Supply current in Wait mode ⁽²⁾	f _{OSC} = 2 MHz, f _{CPU} = 1 MHz	1.0	3.0	1.0	1.3	mA	
	f _{OSC} = 4 MHz, f _{CPU} = 2 MHz	1.5	4.0	1.5	2.0		
	f _{OSC} = 8 MHz, f _{CPU} = 4 MHz	2.5	5.0	2.5	3.3		
	f _{OSC} = 16 MHz, f _{CPU} = 8 MHz	4.5	7.0	4.5	6.0		
Supply current in Slow Wait mode ⁽²⁾	f _{OSC} = 2 MHz, f _{CPU} = 62.5 kHz	580	1200	70	200	μA	
	f _{OSC} = 4 MHz, f _{CPU} = 125 kHz	650	1300	100	300		
	f _{OSC} = 8 MHz, f _{CPU} = 250 kHz	770	1800	200	600		
	f _{OSC} = 16 MHz, f _{CPU} = 500 kHz	1050	2000	350	1200		
Supply current in Halt mode ⁽³⁾	-40°C ≤ T _A ≤ +85°C	<1	10	<1	10	μA	
	-40°C ≤ T _A ≤ +125°C	<1	50	<1	50		
I _{DD}	Supply current in Active Halt mode ⁽⁴⁾	f _{OSC} = 2 MHz	80	No max. guaranteed	80	No max. guaranteed	μA
f _{OSC} = 4 MHz		160	160				
f _{OSC} = 8 MHz		325	325				
f _{OSC} = 16 MHz		650	650				

- Data based on characterization results, tested in production at V_{DD} max. and f_{CPU} max.
- Measurements are done in the following conditions:
 - Program executed from RAM, CPU running with RAM access. The increase in consumption when executing from Flash is 50%.
 - All I/O pins in input mode with a static value at V_{DD} or V_{SS} (no load)
 - All peripherals in reset state.
 - LVD disabled.
 - Clock input (OSC1) driven by external square wave.
 - In Slow and Slow Wait mode, f_{CPU} is based on f_{OSC} divided by 32.
 - To obtain the total current consumption of the device, add the clock source ([Section 19.4.2](#)) and the peripheral power consumption ([Section 19.4.3](#)).
- All I/O pins in push-pull 0 mode (when applicable) with a static value at V_{DD} or V_{SS} (no load), LVD disabled. Data based on characterization results, tested in production at V_{DD} max. and f_{CPU} max.
- Data based on characterization results, not tested in production. All I/O pins in push-pull 0 mode (when applicable) with a static value at V_{DD} or V_{SS} (no load); clock input (OSC1) driven by external square wave, LVD disabled. To obtain the total current consumption of the device, add the clock source consumption ([Section 19.4.2](#)).

Power consumption vs f_{CPU} : Flash devices

Figure 74. Typical I_{DD} in Run mode

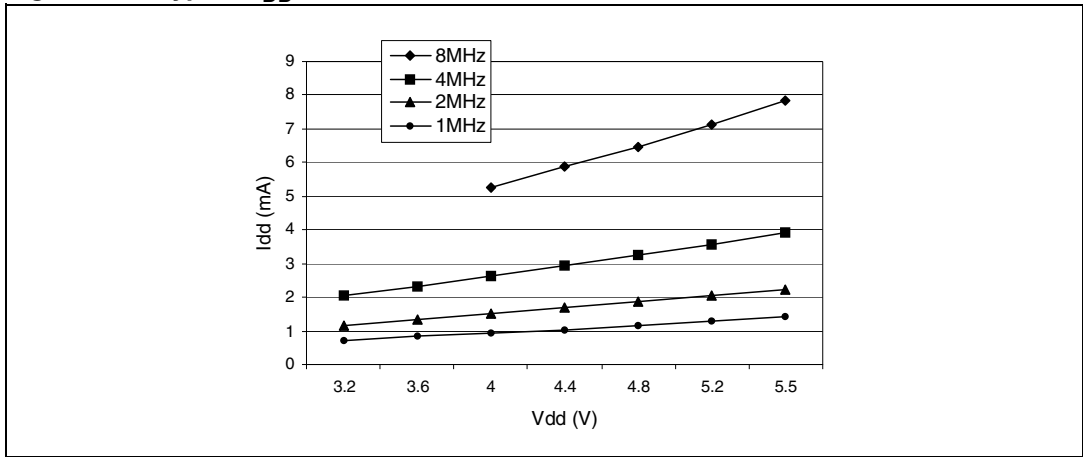

Figure 75. Typical I_{DD} in Slow mode

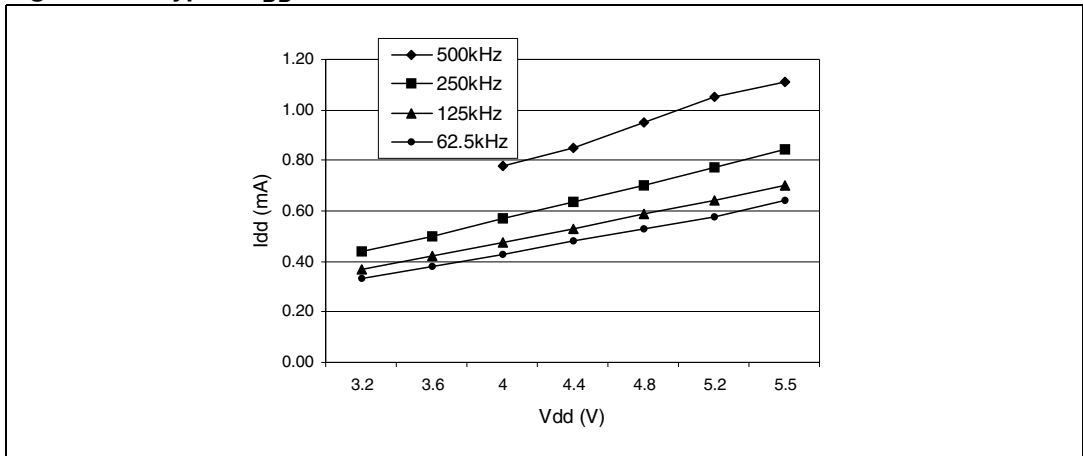

Figure 76. Typical I_{DD} in Wait mode

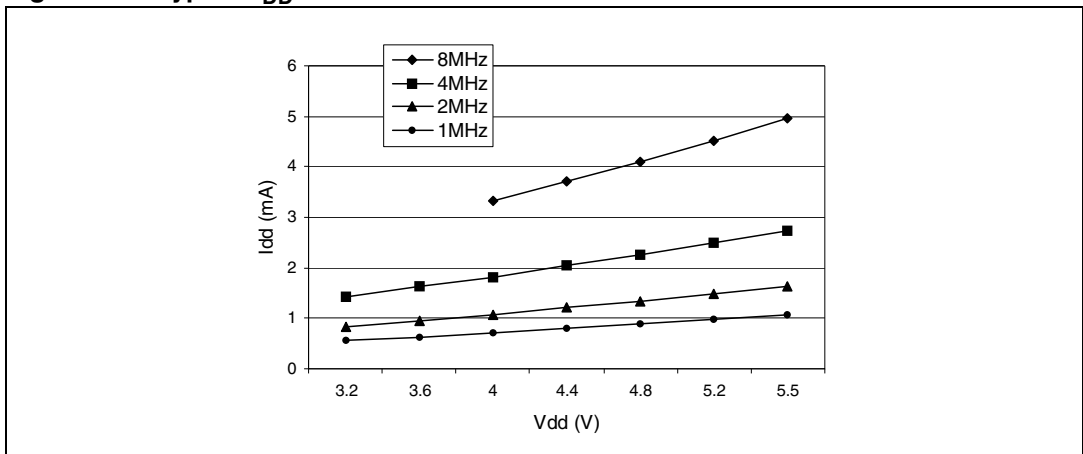
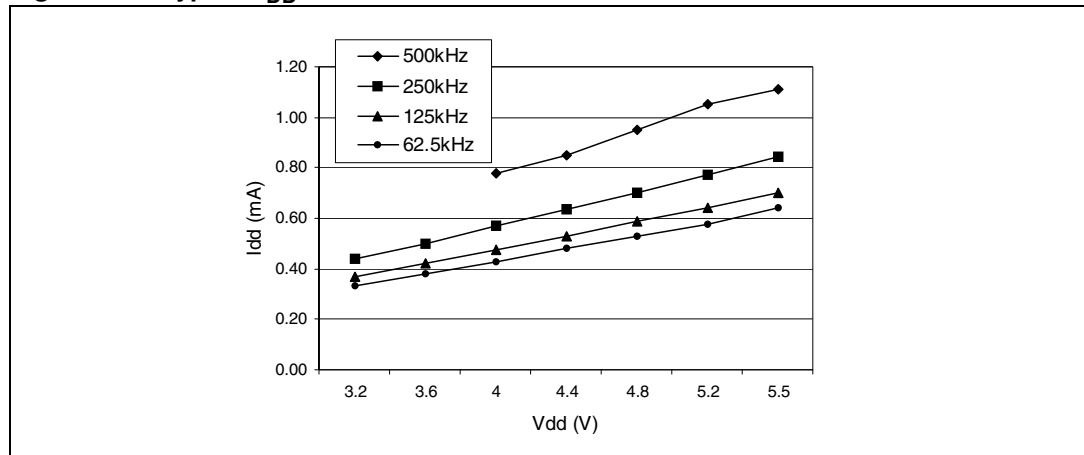

Figure 77. Typical I_{DD} in Slow Wait mode



19.4.2 Supply and clock managers

The previous current consumption specified for the ST7 functional operating modes over temperature range does not take into account the clock source current consumption. To obtain the total device consumption, the two current values must be added (except for Halt mode).

Table 112. Oscillators, PLL and LVD current consumption

Symbol	Parameter	Conditions	Typ	Max	Unit
I _{DD} (RCINT)	Supply current of internal RC oscillator		625		μA
I _{DD} (RES)	Supply current of resonator oscillator ⁽¹⁾⁽²⁾		see section 19.5.3 on page 196		
I _{DD} (PLL)	PLL supply current	V _{DD} = 5V	360		
I _{DD} (LVD)	LVD supply current		150	300	

1. Data based on characterization results done with the external components specified in [Section 19.5.3](#), not tested in production
2. As the oscillator is based on a current source, the consumption does not depend on the voltage.

19.4.3 On-chip peripherals

Measured on LQFP64 generic board $T_A = 25^\circ\text{C}$, $f_{\text{CPU}} = 4 \text{ MHz}$.

Table 113. On-chip peripherals current consumption

Symbol	Parameter	Conditions	Typ	Unit
$I_{\text{DD(TIM)}}$	16-bit timer supply current ⁽¹⁾	$V_{\text{DD}} = 5.0\text{V}$	50	μA
$I_{\text{DD(ART)}}$	ART PWM supply current ⁽²⁾	$V_{\text{DD}} = 5.0\text{V}$	75	μA
$I_{\text{DD(SPI)}}$	SPI supply current ⁽³⁾	$V_{\text{DD}} = 5.0\text{V}$	400	μA
$I_{\text{DD(SCI)}}$	SCI supply current ⁽⁴⁾			
$I_{\text{DD(I2C)}}$	I2C supply current ⁽⁵⁾	$V_{\text{DD}} = 5.0\text{V}$	175	μA
$I_{\text{DD(ADC)}}$	ADC supply current when converting ⁽⁶⁾	$V_{\text{DD}} = 5.0\text{V}$	400	μA

1. Data based on a differential I_{DD} measurement between reset configuration (timer counter running at $f_{\text{CPU}}/4$) and timer counter stopped (only TIMD bit set). Data valid for one timer.
2. Data based on a differential I_{DD} measurement between reset configuration (timer stopped) and timer counter enabled (only TCE bit set).
3. Data based on a differential I_{DD} measurement between reset configuration (SPI disabled) and a permanent SPI master communication at maximum speed (data sent equal to 55h). This measurement includes the pad toggling consumption.
4. Data based on a differential I_{DD} measurement between SCI low power state (SCID = 1) and a permanent SCI data transmit sequence.
5. Data based on a differential I_{DD} measurement between reset configuration (I2C disabled) and a permanent I2C master communication at 100 kHz (data sent equal to 55h). This measurement includes the pad toggling consumption (27k ohm external pull-up on clock and data lines).
6. Data based on a differential I_{DD} measurement between reset configuration and continuous A/D conversions.

19.5 Clock and timing characteristics

Subject to general operating conditions for V_{DD} , f_{CPU} , and T_A .

19.5.1 General timings

Table 114. General timings

Symbol	Parameter	Conditions	Min	Typ ⁽¹⁾	Max	Unit
$t_{c(INST)}$	Instruction cycle time		2	3	12	t_{CPU}
		$f_{CPU} = 8 \text{ MHz}$	250	375	1500	ns
$t_{v(IT)}$	Interrupt reaction time ⁽²⁾ $t_{v(IT)} = \Delta t_{c(INST)} + 10$		10		22	t_{CPU}
		$f_{CPU} = 8 \text{ MHz}$	1.25		2.75	μs

1. Data based on typical application software.
2. Time measured between interrupt event and interrupt vector fetch. $\Delta t_{c(INST)}$ is the number of t_{CPU} cycles needed to finish the current instruction execution.

19.5.2 External clock source

Table 115. External clock source

Symbol	Parameter	Conditions	Min	Typ	Max	Unit
V_{OSC1H}	OSC1 input pin high level voltage	See Figure 78	$0.7 \times V_{DD}$		V_{DD}	V
V_{OSC1L}	OSC1 input pin low level voltage		V_{SS}		$0.3 \times V_{DD}$	
$t_{w(OSC1H)}$ $t_{w(OSC1L)}$	OSC1 high or low time ⁽¹⁾		5			ns
$t_r(OSC1)$ $t_f(OSC1)$	OSC1 rise or fall time ⁽¹⁾				15	
I_{lkg}	OSC1 input leakage current	$V_{SS} \leq V_{IN} \leq V_{DD}$			± 1	μA

1. Data based on design simulation and/or technology characteristics, not tested in production.

Figure 78. Typical application with an external clock source

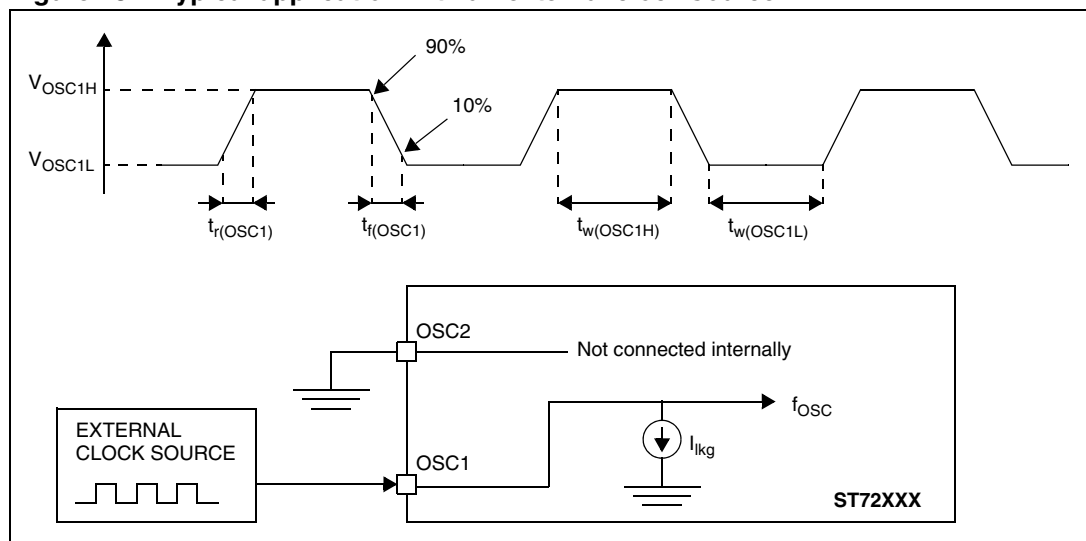

19.5.3 Crystal and ceramic resonator oscillators

The ST7 internal clock can be supplied with four different crystal/ceramic resonator oscillators. All the information given in this paragraph is based on characterization results with specified typical external components. In the application, the resonator and the load capacitors have to be placed as close as possible to the oscillator pins in order to minimize output distortion and start-up stabilization time. Refer to the crystal/ceramic resonator manufacturer for more details (such as frequency, package or accuracy).

Table 116. Crystal and ceramic resonator oscillators

Symbol	Parameter	Conditions	Min	Typ	Max	Unit
f_{OSC}	Oscillator frequency ⁽¹⁾	LP: Low power oscillator MP: Medium power oscillator MS: Medium speed oscillator HS: High speed oscillator	1 >2 >4 >8	-	2 4 8 16	MHz
R_F	Feedback resistor ⁽²⁾	-	20	-	40	k Ω
C_{L1} C_{L2}	Recommended load capacitance versus equivalent serial resistance of the crystal or ceramic resonator (R_S) ⁽³⁾	$R_S = 200\Omega$ $R_S = 200\Omega$ $R_S = 200\Omega$ $R_S = 100\Omega$	LP oscillator MP oscillator MS oscillator HS oscillator	22 22 18 15	- - - -	56 46 33 33 pF
i_2	OSC2 driving current	$V_{DD} = 5V, V_{IN} = V_{SS}$	LP oscillator MP oscillator MS oscillator HS oscillator	- - - -	80 160 310 610	150 250 460 910 μA

1. The oscillator selection can be optimized in terms of supply current using a high-quality resonator with small R_S value. Refer to crystal/ceramic resonator manufacturer for more details.
2. Data based on characterization results, not tested in production. The relatively low value of the R_F resistor offers a good protection against issues resulting from use in a humid environment, due to the induced leakage and the bias condition change. However, it is recommended to take this point into account if the microcontroller is used in tough humidity conditions.
3. For C_{L1} and C_{L2} it is recommended to use high-quality ceramic capacitors in the 5pF to 25pF range (typ.) designed for high-frequency applications and selected to match the requirements of the crystal or resonator. C_{L1} and C_{L2} are usually the same size. The crystal manufacturer typically specifies a load capacitance which is the series combination of C_{L1} and C_{L2} . PCB and MCU pin capacitance must be included when sizing C_{L1} and C_{L2} (10pF can be used as a rough estimate of the combined pin and board capacitance).

Figure 79. Typical application with a crystal or ceramic resonator)

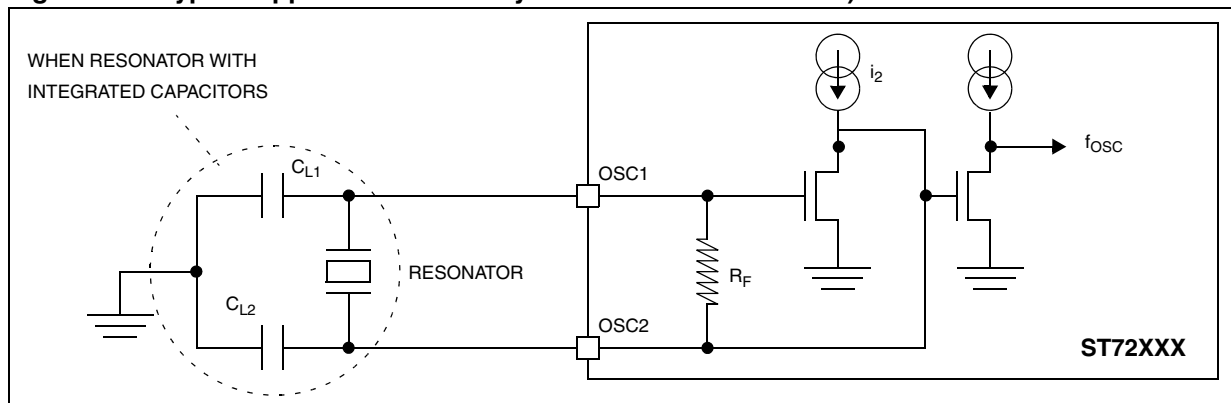

Table 117. OSCRANGE selection for typical resonators

Supplier	f _{osc} (MHz)	Typical ceramic resonators ⁽¹⁾	
		Reference	Recommended OSCRANGE option bit configuration
Murata	2	CSTCC2M00G56A-R0	MP mode ⁽²⁾
	4	CSTCR4M00G55B-R0	MS mode
	8	CSTCE8M00G55A-R0	HS mode
	16	CSTCE16M0G53A-R0	

1. Resonator characteristics given by the ceramic resonator manufacturer. For more information on these resonators, please consult www.murata.com.
2. LP mode is not recommended for 2 MHz resonator because the peak to peak amplitude is too small (> 0.8V).

19.5.4 RC oscillators

Table 118. RC oscillator characteristics

Symbol	Parameter	Conditions	Min	Typ	Max	Unit
f _{OSC(RCINT)}	Internal RC oscillator frequency (see Figure 80)	T _A = 25°C, V _{DD} = 5V	2	3.5	5.6	MHz

Figure 80. Typical f_{OSC(RCINT)} versus T_A

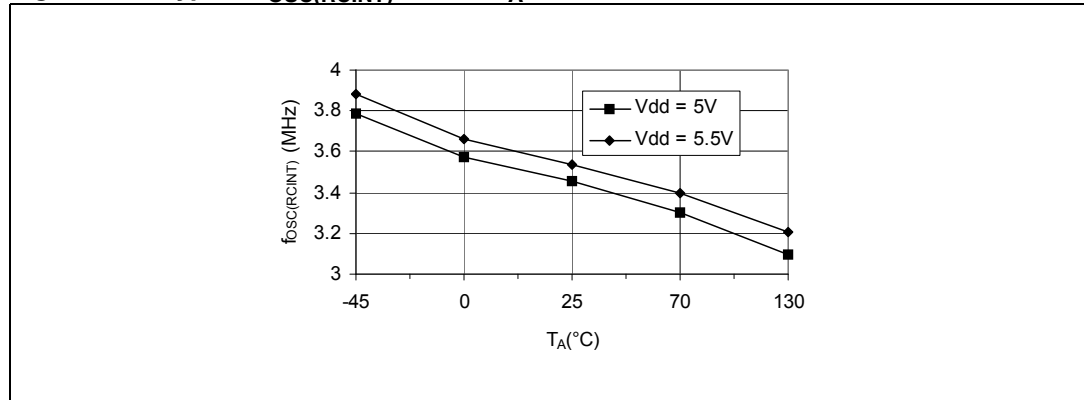

Note: To reduce disturbance to the RC oscillator, it is recommended to place decoupling capacitors between V_{DD} and V_{SS} as shown in [Figure 100](#).

19.5.5 PLL characteristics

Table 119. PLL characteristics

Symbol	Parameter	Conditions	Min	Typ	Max	Unit
f_{OSC}	PLL input frequency range		2		4	MHz
$\Delta f_{CPU}/f_{CPU}$	Instantaneous PLL jitter ⁽¹⁾	$f_{OSC} = 4 \text{ MHz}$		1.0	2.5	%
		$f_{OSC} = 2 \text{ MHz}$		2.5	4.0	

1. Data based on characterization results

The user must take the PLL jitter into account in the application (for example, in serial communication or sampling of high frequency signals). The PLL jitter is a periodic effect, which is integrated over several CPU cycles. Therefore, the longer the period of the application signal, the less it is impacted by the PLL jitter.

Figure 81 shows the PLL jitter integrated on application signals in the range 125 kHz to 4 MHz. At frequencies of less than 125 kHz, the jitter is negligible.

Figure 81. Integrated PLL jitter versus signal frequency⁽¹⁾

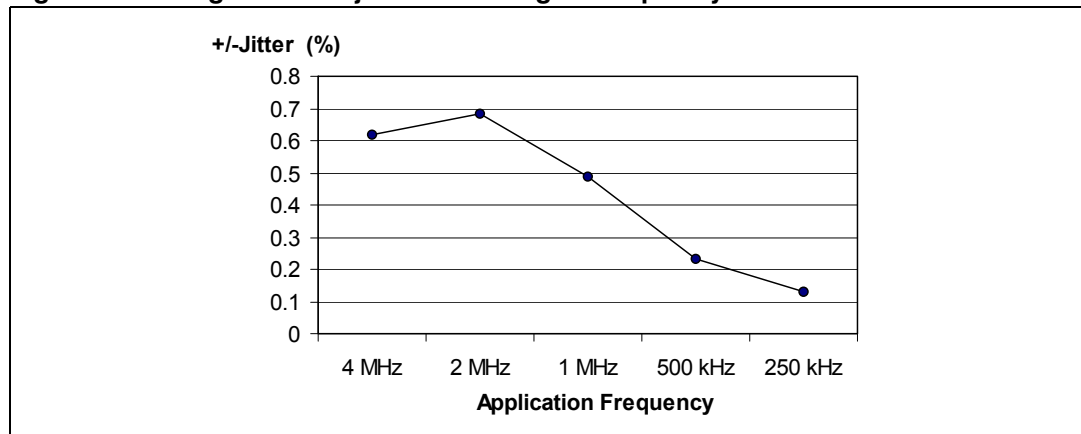

1. Measurement conditions: $f_{CPU} = 8 \text{ MHz}$

19.6 Memory characteristics

19.6.1 RAM and hardware registers

Table 120. RAM supply voltage

Symbol	Parameter	Conditions	Min	Typ	Max	Unit
V_{RM}	Data retention mode ⁽¹⁾	Halt mode (or RESET)	1.6			V

1. Minimum V_{DD} supply voltage without losing data stored in RAM (in Halt mode or under RESET) or in hardware registers (only in Halt mode). Not tested in production.

19.6.2 Flash memory

Table 121. Dual voltage HDFlash memory

Symbol	Parameter	Conditions	Min ⁽¹⁾	Typ	Max ⁽¹⁾	Unit
f_{CPU}	Operating frequency	Read mode	0		8	MHz
		Write / Erase mode	1		8	
V_{PP}	Programming voltage ⁽²⁾	$4.5V \leq V_{DD} \leq 5.5V$	11.4		12.6	V
I_{DD}	Supply current ⁽³⁾	Run mode ($f_{CPU} = 4$ MHz)			3	mA
		Write / Erase		0		
		Power down mode / HALT		1	10	μA
I_{PP}	V_{PP} current ⁽³⁾	Read ($V_{PP} = 12V$)			200	μA
		Write / Erase			30	mA
t_{VPP}	Internal V_{PP} stabilization time			10		μs
t_{RET}	Data retention	$T_A = 55^\circ C$	20			years
N_{RW}	Write erase cycles	$T_A = 85^\circ C$	100			cycles
T_{PROG} T_{ERASE}	Programming or erasing temperature range		-40	25	85	$^\circ C$

1. Data based on characterization results, not tested in production

2. V_{PP} must be applied only during the programming or erasing operation and not permanently for reliability reasons.

3. Data based on simulation results, not tested in production

Warning: Do not connect 12V to V_{PP} before V_{DD} is powered on, as this may damage the device.

19.7 EMC (electromagnetic compatibility) characteristics

Susceptibility tests are performed on a sample basis during product characterization.

19.7.1 Functional EMS (electromagnetic susceptibility)

Based on a simple running application on the product (toggling two LEDs through I/O ports), the product is stressed by two electromagnetic events until a failure occurs (indicated by the LEDs).

- **ESD:** Electrostatic discharge (positive and negative) is applied on all pins of the device until a functional disturbance occurs. This test conforms with the IEC 1000-4-2 standard.
- **FTB:** A burst of fast transient voltage (positive and negative) is applied to V_{DD} and V_{SS} through a 100pF capacitor until a functional disturbance occurs. This test conforms with the IEC 1000-4-4 standard.

A device reset allows normal operations to be resumed. The test results given in [Table 122](#) below are based on the EMS levels and classes defined in application note AN1709.

Designing hardened software to avoid noise problems

EMC characterization and optimization are performed at component level with a typical application environment and simplified MCU software. It should be noted that good EMC performance is highly dependent on the user application and the software in particular.

Therefore it is recommended that the user applies EMC software optimization and prequalification tests in relation with the EMC level requested for his application.

Software recommendations

The software flowchart must include the management of runaway conditions such as:

- Corrupted program counter
- Unexpected reset
- Critical Data corruption (control registers...)

Prequalification trials

Most of the common failures (unexpected reset and program counter corruption) can be reproduced by manually forcing a low state on the \overline{RESET} pin or the oscillator pins for 1 second.

To complete these trials, ESD stress can be applied directly on the device, over the range of specification values. When unexpected behavior is detected, the software can be hardened to prevent unrecoverable errors occurring (see application note AN1015).

Table 122. EMS test results

Symbol	Parameter	Conditions	Level/Class
V _{FESD}	Voltage limits to be applied on any I/O pin to induce a functional disturbance	Flash device: V _{DD} = 5V, T _A = +25°C, f _{OSC} = 8 MHz, conforms to IEC 1000-4-2	4B
		ROM device: V _{DD} = 5V, T _A = +25°C, f _{OSC} = 8 MHz, conforms to IEC 1000-4-2	4A
V _{FFTB}	Fast transient voltage burst limits to be applied through 100pF on V _{DD} and V _{DD} pins to induce a functional disturbance	V _{DD} = 5V, T _A = +25°C, f _{OSC} = 8 MHz, conforms to IEC 1000-4-4	3B

19.7.2 EMI (electromagnetic interference)

Based on a simple application running on the product (toggling two LEDs through the I/O ports), the product is monitored in terms of emission. This emission test is in line with the norm SAE J 1752/3 which specifies the board and the loading of each pin.

Table 123. EMI emissions

Symbol	Parameter	Conditions	Monitored frequency band	Max vs [f _{OSC} /f _{CPU}] ⁽¹⁾		Unit
		V _{DD} = 5V, T _A = +25°C, conforming to SAE J 1752/3		8/4 MHz	16/8 MHz	
S _{EMI}	Peak level	60 Kbyte Flash devices in LQFP64 package	0.1 MHz to 30 MHz	15	20	dBµV
			30 MHz to 130 MHz	20	27	
			130 MHz to 1 GHz	0	5	
			SAE EMI Level	2.5	3	-

1. Data based on characterization results, not tested in production.

19.7.3 Absolute maximum ratings (electrical sensitivity)

Based on two different tests (ESD and LU) using specific measurement methods, the product is stressed in order to determine its performance in terms of electrical sensitivity. For more details, refer to the application note AN1181.

Electrostatic discharge (ESD)

Electrostatic discharges (a positive then a negative pulse separated by 1 second) are applied to the pins of each sample according to each pin combination. The sample size depends on the number of supply pins in the device (3 parts*(n+1) supply pin). Two models can be simulated: Human Body Model and Machine Model. This test conforms to the JESD22-A114A/A115A standard.

Table 124. ESD absolute maximum ratings

Symbol	Ratings	Conditions	Max. value ⁽¹⁾	Unit
V _{ESD(HBM)}	Electrostatic discharge voltage (Human Body Model)	T _A = +25°C	2000	V
V _{ESD(MM)}	Electrostatic discharge voltage (Machine Model)		200	

1. Data based on characterization results, not tested in production.

Static latch-up (LU) Two complementary static tests are required on six parts to assess the latch-up performance:

- A supply overvoltage is applied to each power supply pin.
- A current injection is applied to each input, output and configurable I/O pin.

These tests are compliant with the EIA/JESD 78 IC latch-up standard.

Table 125. Electrical sensitivities

Symbol	Parameter	Conditions	Class ⁽¹⁾
LU	Static latch-up class	T _A = +25°C	A
		T _A = +85°C	A
		T _A = +125°C	A

1. Class description: A Class is an STMicroelectronics internal specification. All its limits are higher than the JEDEC specifications, that means when a device belongs to Class A it exceeds the JEDEC standard. B Class strictly covers all the JEDEC criteria (international standard).

19.8 I/O port pin characteristics

19.8.1 General characteristics

Subject to general operating conditions for V_{DD} , f_{OSC} , and T_A unless otherwise specified.

Table 126. I/O port pin general characteristics

Symbol	Parameter	Conditions	Min	Typ	Max	Unit
V_{IL}	Input low level voltage ⁽¹⁾	CMOS ports			$0.3 \times V_{DD}$	V
V_{IH}	Input high level voltage ⁽¹⁾		$0.7 \times V_{DD}$			
V_{hys}	Schmitt trigger voltage hysteresis ⁽²⁾			0.7		
$I_{INJ(PIN)}^{(3)}$	Injected current on PC6 pin (Flash devices only)	$V_{DD} = 5V$	0		+4	mA
	Injected current on an I/O pin				± 4	
$\Sigma I_{INJ(PIN)}^{(3)}$	Total injected current (sum of all I/O and control pins)					
I_L	Input leakage current	$V_{SS} \leq V_{IN} \leq V_{DD}$			± 1	μA
I_S	Static current consumption	Floating input mode ⁽⁴⁾		400		
R_{PU}	Weak pull-up equivalent resistor ⁽⁵⁾	$V_{IN} = V_{SS}$ $V_{DD} = 5V$	50	120	250	k Ω
C_{IO}	I/O pin capacitance			5		pF
$t_{f(I/O)out}$	Output high to low level fall time ⁽¹⁾	$C_L = 50pF$ Between 10% and 90%		25		ns
$t_{r(I/O)out}$	Output low to high level rise time ⁽¹⁾			25		
$t_{w(IT)in}$	External interrupt pulse time ⁽⁶⁾		1			t_{CPU}

1. Data based on characterization results, not tested in production.
2. Hysteresis voltage between Schmitt trigger switching levels. Based on characterization results, not tested.
3. When the current limitation is not possible, the V_{IN} maximum must be respected, otherwise refer to $I_{INJ(PIN)}$ specification. A positive injection is induced by $V_{IN} > V_{DD}$ while a negative injection is induced by $V_{IN} < V_{SS}$. Refer to [Section 19.2.2: Current characteristics](#) for more details.
4. Configuration not recommended. All unused pins must be kept at a fixed voltage. This can be done by using the output mode of the I/O, for example, and leaving the I/O unconnected on the board or by an external pull-up or pull-down resistor (see [Figure 82](#)). Static peak current value taken at a fixed V_{IN} value, based on design simulation and technology characteristics, not tested in production. This value depends on V_{DD} and temperature values.
5. The R_{PU} pull-up equivalent resistor is based on a resistive transistor (corresponding I_{PU} current characteristics described in [Figure 83](#)).
6. To generate an external interrupt, a minimum pulse width has to be applied on an I/O port pin configured as an external interrupt source.

Figure 82. Unused I/O pins configured as input

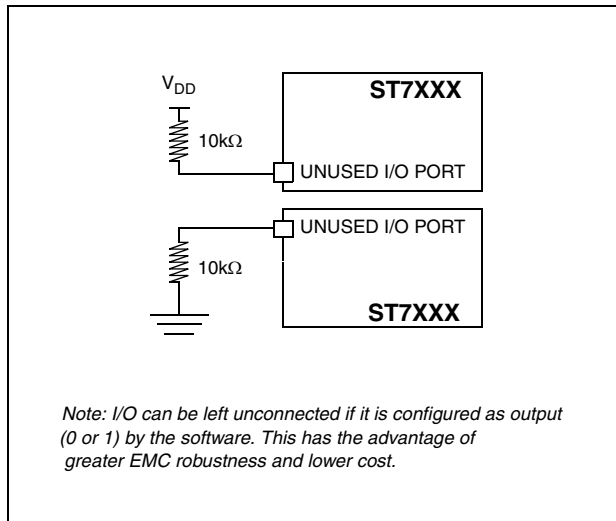
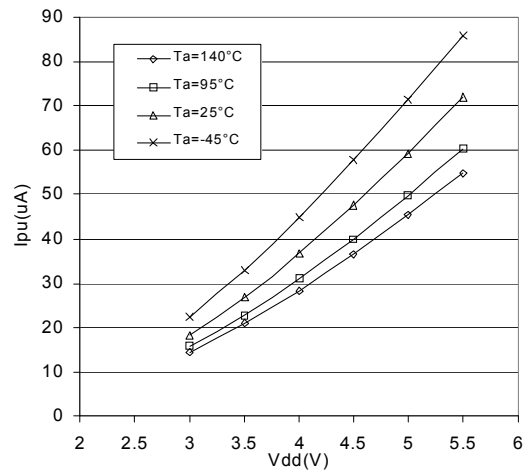

Figure 83. Typical I_{PU} vs V_{DD} with V_{IN} = V_{SS}



19.8.2 Output driving current

Subject to general operating conditions for V_{DD}, f_{CPU}, and T_A unless otherwise specified.

Table 127. Output driving current

Symbol	Parameter	Conditions	Min	Max	Unit
V _{OL} ⁽¹⁾	Output low level voltage for a standard I/O pin when 8 pins are sunk at same time (see Figure 84)	I _{IO} = +5mA		1.2	V
		I _{IO} = +2mA		0.5	
V _{OL} ⁽¹⁾	Output low level voltage for a high sink I/O pin when 4 pins are sunk at same time (see Figure 85 and Figure 87)	V _{DD} = 5V	I _{IO} = +20mA, T _A ≤ 85°C	1.3	
			T _A ≥ 85°C	1.5	
V _{OH} ⁽²⁾	Output high level voltage for an I/O pin when 4 pins are sourced at same time (see Figure 86 and Figure 89)	V _{DD} = 5V	I _{IO} = +8mA	0.6	
			I _{IO} = -5mA, T _A ≤ 85°C	V _{DD} - 1.4	
			T _A ≥ 85°C	V _{DD} - 1.6	
			I _{IO} = -2mA	V _{DD} - 0.7	

- The I_{IO} current sunk must always respect the absolute maximum rating specified in [Section 19.2.2](#) and the sum of I_{IO} (I/O ports and control pins) must not exceed I_{VSS}.
- The I_{IO} current sourced must always respect the absolute maximum rating specified in [Section 19.2.2](#) and the sum of I_{IO} (I/O ports and control pins) must not exceed I_{VDD}. True open-drain I/O pins do not have V_{OH}.

Figure 84. Typical V_{OL} at $V_{DD} = 5V$ (standard)

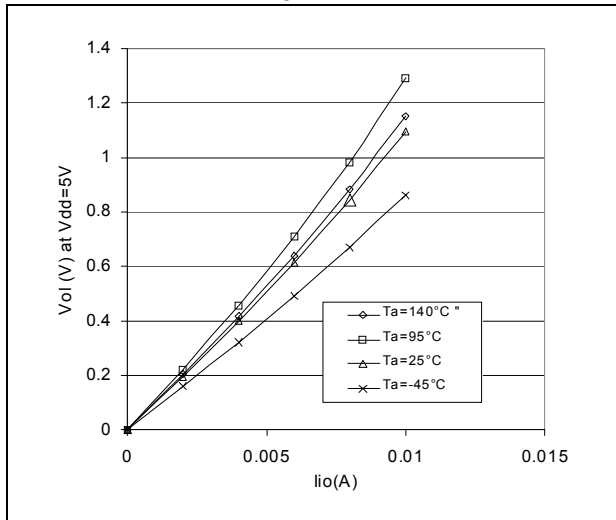

Figure 85. Typical V_{OL} at $V_{DD} = 5V$ (high-sink)

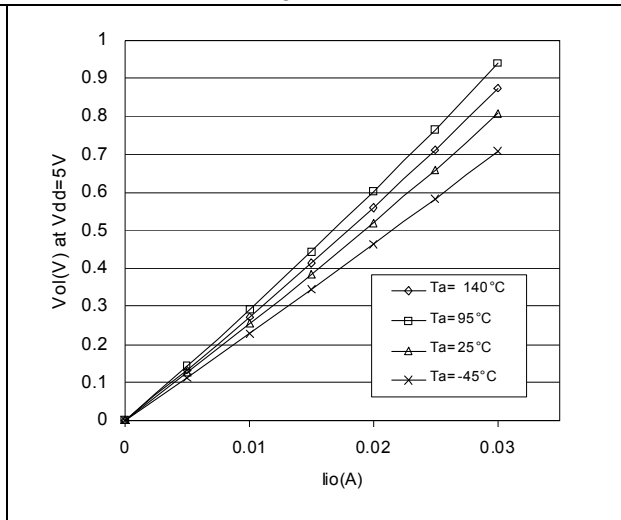

Figure 86. Typical V_{OH} at $V_{DD} = 5V$

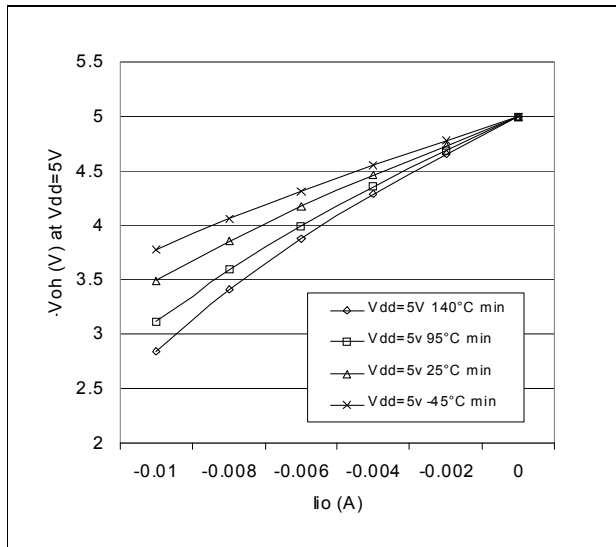

Figure 87. Typical V_{OL} versus V_{DD} (standard)

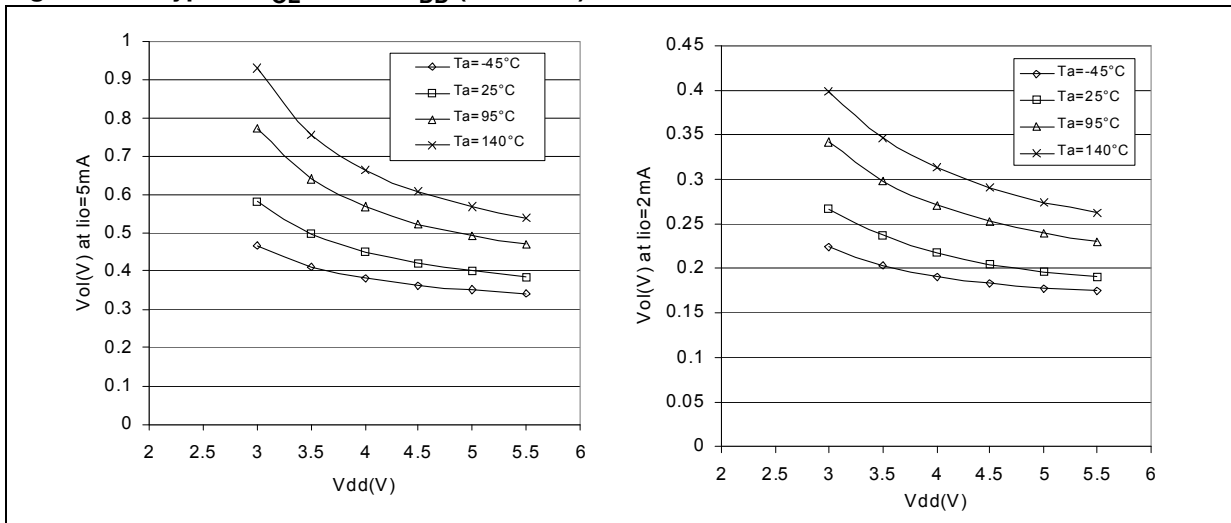

Figure 88. Typical V_{OL} versus V_{DD} (high-sink)

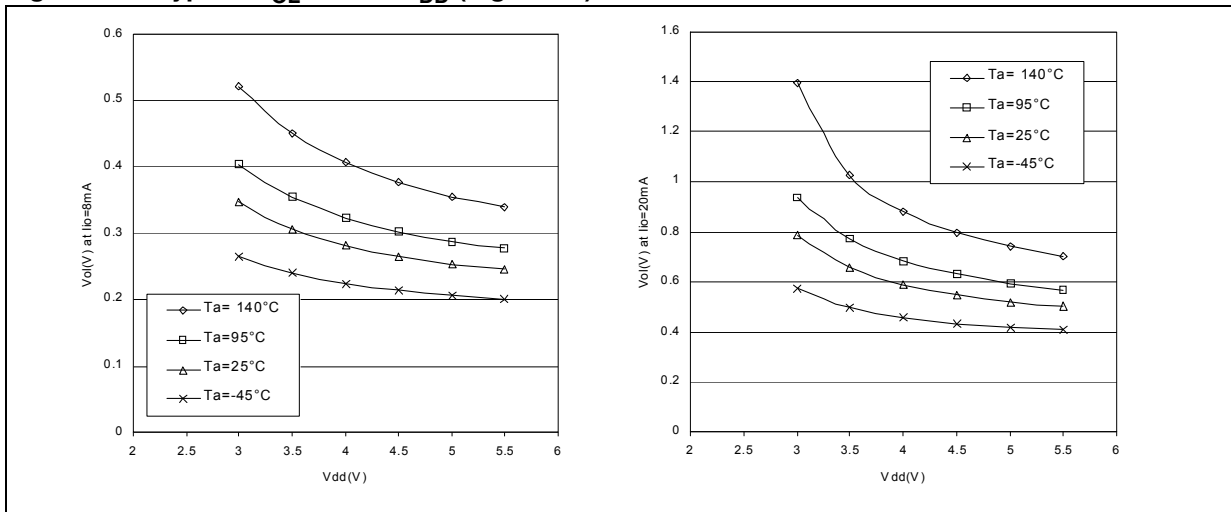
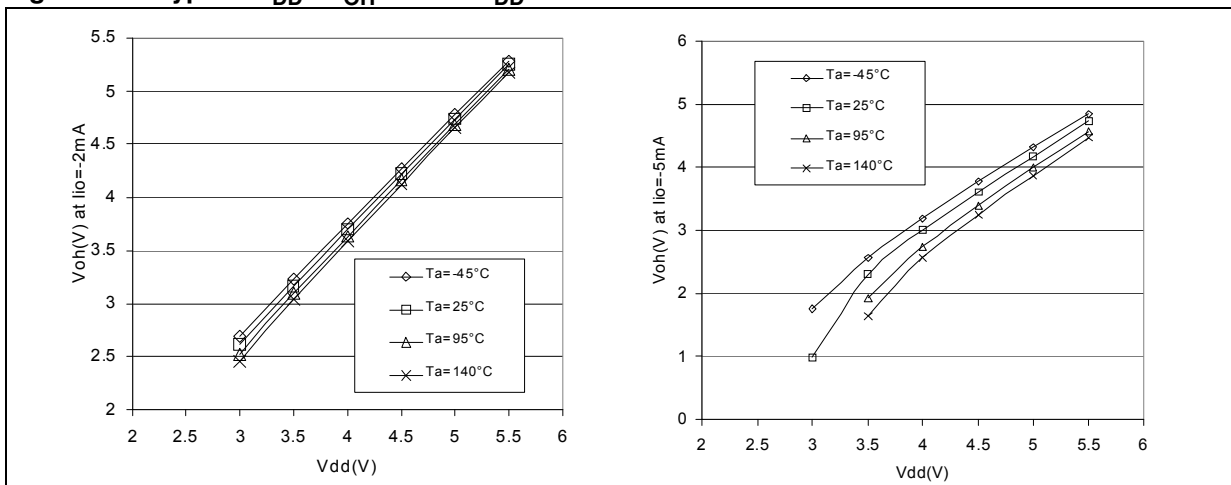

Figure 89. Typical $V_{DD} - V_{OH}$ versus V_{DD}



19.9 Control pin characteristics

19.9.1 Asynchronous $\overline{\text{RESET}}$ pin

Subject to general operating conditions for V_{DD} , f_{CPU} , and T_A unless otherwise specified.

Table 128. Asynchronous $\overline{\text{RESET}}$ pin characteristics

Symbol	Parameter	Conditions	Min	Typ	Max	Unit
V_{IL}	Input low level voltage ⁽¹⁾				$0.16 \times V_D$	V
V_{IH}	Input high level voltage ⁽¹⁾		$0.85 \times V_D$			
V_{hys}	Schmitt trigger voltage hysteresis ⁽²⁾			2.5		
V_{OL}	Output low level voltage ⁽³⁾	$V_{DD} = 5V, I_{IO} = +2mA$		0.2	0.5	
I_{IO}	Input current on $\overline{\text{RESET}}$ pin			2		mA
R_{ON}	Weak pull-up equivalent resistor		20	30	120	k Ω
$t_{w(RSTL)out}$	Generated reset pulse duration	Stretch applied on external pulse	0		$42^{(4)}$	μs
		Internal reset sources	20	30	$42^{(4)}$	
$t_{h(RSTL)in}$	External reset pulse hold time ⁽⁵⁾		2.5			
$t_{g(RSTL)in}$	Filtered glitch duration ⁽⁶⁾			200		ns

1. Data based on characterization results, not tested in production.
2. Hysteresis voltage between Schmitt trigger switching levels.
3. The I_{IO} current sunk must always respect the absolute maximum rating specified in [Section 19.2.2](#) and the sum of I_{IO} (I/O ports and control pins) must not exceed I_{VSS} .
4. Data guaranteed by design, not tested in production.
5. To guarantee the reset of the device, a minimum pulse has to be applied to the $\overline{\text{RESET}}$ pin. All short pulses applied on the $\overline{\text{RESET}}$ pin with a duration below $t_{h(RSTL)in}$ can be ignored.
6. The reset network (the resistor and two capacitors) protects the device against parasitic resets, especially in noisy environments.

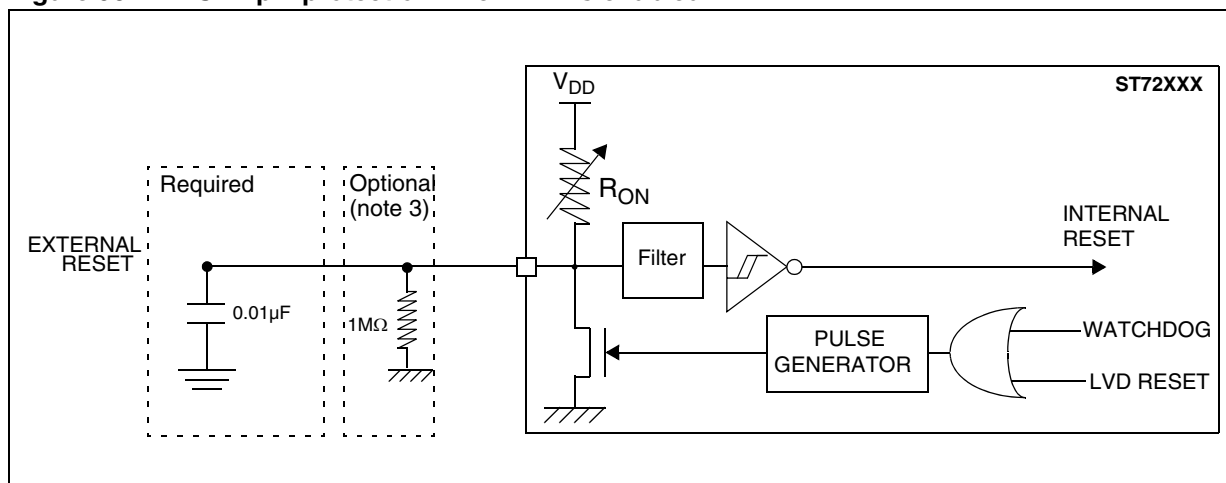
Figure 90. $\overline{\text{RESET}}$ pin protection when LVD is enabled

Note: 1 The reset network protects the device against parasitic resets.

The output of the external reset circuit must have an open-drain output to drive the ST7 reset pad. Otherwise the device can be damaged when the ST7 generates an internal reset (LVD or watchdog).

Whether the reset source is internal or external, the user must ensure that the level on the $\overline{\text{RESET}}$ pin can go below the V_{IL} maximum level specified in Section 19.9.1 on page 207. Otherwise the reset will not be taken into account internally.

Because the reset circuit is designed to allow the internal $\overline{\text{RESET}}$ to be output in the $\overline{\text{RESET}}$ pin, the user must ensure that the current sunk on the $\overline{\text{RESET}}$ pin is less than the absolute maximum value specified for $I_{INJ}(\overline{\text{RESET}})$ in Section 19.2.2 on page 187.

- 2 When the LVD is enabled, it is recommended not to connect a pull-up resistor or capacitor. A 10nF pull-down capacitor is required to filter noise on the reset line.
- 3 In case a capacitive power supply is used, it is recommended to connect a 1MΩ pull-down resistor to the $\overline{\text{RESET}}$ pin to discharge any residual voltage induced by the capacitive effect of the power supply (this will add 5µA to the power consumption of the MCU).
- 4 Tips when using the LVD:
 - A. Check that all recommendations related to reset circuit have been applied (see notes above).
 - B. Check that the power supply is properly decoupled (100nF + 10µF close to the MCU). Refer to AN1709 and AN2017. If this cannot be done, it is recommended to put a 100nF + 1MΩ pull-down on the $\overline{\text{RESET}}$ pin.
 - C. The capacitors connected on the $\overline{\text{RESET}}$ pin and also the power supply are key to avoid any start-up marginality. In most cases, steps A and B above are sufficient for a robust solution. Otherwise, replace 10nF pull-down on the $\overline{\text{RESET}}$ pin with a 5µF to 20µF capacitor.

Figure 91. $\overline{\text{RESET}}$ pin protection when LVD is disabled

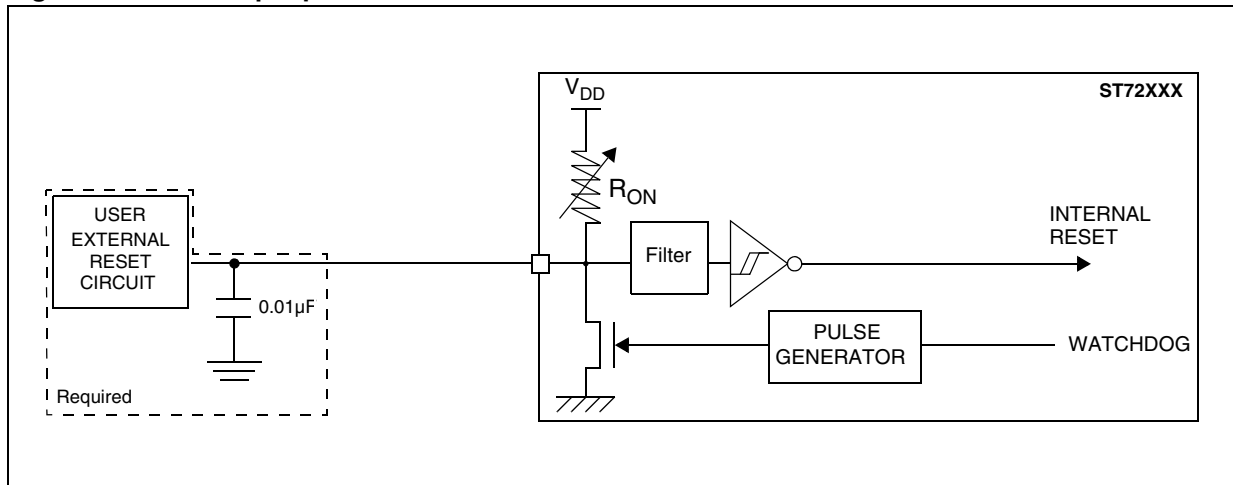

Note: The reset network protects the device against parasitic resets. The output of the external reset circuit must have an open-drain output to drive the ST7 reset pad. Otherwise the device can be damaged when the ST7 generates an internal reset (LVD or watchdog).

Whether the reset source is internal or external, the user must ensure that the level on the $\overline{\text{RESET}}$ pin can go below the V_{IL} maximum level specified in Section 19.9.1 on page 207. Otherwise the reset will not be taken into account internally.

Because the reset circuit is designed to allow the internal RESET to be output in the $\overline{\text{RESET}}$ pin, the user must ensure that the current sunk on the $\overline{\text{RESET}}$ pin is less than the absolute maximum value specified for $I_{INJ}(\overline{\text{RESET}})$ in Section 19.2.2 on page 187.

19.9.2 ICCSEL/V_{PP} pin

Subject to general operating conditions for V_{DD} , f_{CPU} , and T_A unless otherwise specified.

Table 129. ICCSEL/V_{PP} pin characteristics

Symbol	Parameter	Conditions	Min	Max	Unit
V_{IL}	Input low level voltage ⁽¹⁾	Flash versions	V_{SS}	0.2	V
		ROM versions	V_{SS}	$0.3 \times V_{DD}$	
V_{IH}	Input high level voltage ⁽¹⁾	Flash versions	$V_{DD} - 0.1$	12.6	V
		ROM versions	$0.7 \times V_{DD}$	V_{DD}	
I_L	Input leakage current	$V_{IN} = V_{SS}$		± 1	μA

1. Data based on design simulation and/or technology characteristics, not tested in production.

Figure 92. Two typical applications with ICCSEL/V_{PP} pin⁽¹⁾

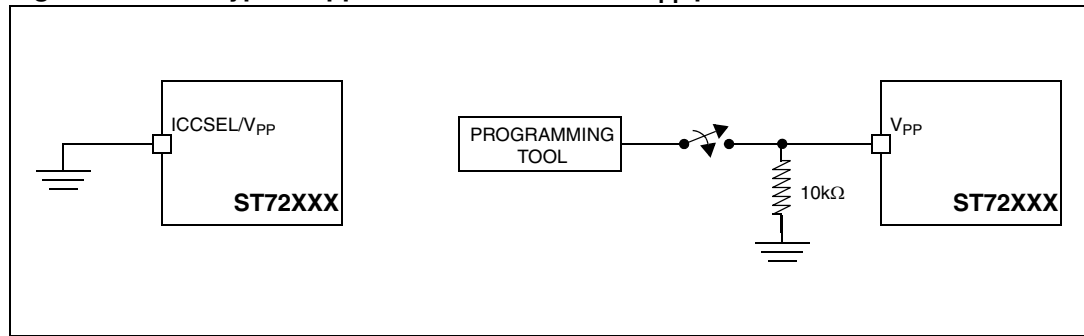

1. When ICC mode is not required by the application, the ICCSEL/V_{PP} pin must be tied to V_{SS}.

19.10 Timer peripheral characteristics

Subject to general operating conditions for V_{DD}, f_{OSC}, and T_A unless otherwise specified.

Refer to [Section 19.8: I/O port pin characteristics](#) for more details on the input/output alternate function characteristics (such as output compare, input capture, external clock, or PWM output).

Table 130. 8-bit PWM-ART auto-reload timer characteristics

Symbol	Parameter	Conditions	Min	Typ	Max	Unit
t _{res(PWM)}	PWM resolution time		1			t _{CPU}
		f _{CPU} = 8 MHz	125			ns
f _{EXT}	ART external clock frequency		0		f _{CPU} /2	MHz
f _{PWM}	PWM repetition rate					
Res _{PWM}	PWM resolution				8	bit
V _{OS}	PWM/DAC output step voltage	V _{DD} = 5V, Resolution = 8 bits		20		mV

Table 131. 16-bit timer characteristics

Symbol	Parameter	Conditions	Min	Typ	Max	Unit
t _{w(ICAP)in}	Input capture pulse time		1			t _{CPU}
t _{res(PWM)}	PWM resolution time		2			t _{CPU}
		f _{CPU} = 8 MHz	250			ns
f _{EXT}	Timer external clock frequency		0		f _{CPU} /4	MHz
f _{PWM}	PWM repetition rate					
Res _{PWM}	PWM resolution				16	bit

19.11 Communication interface characteristics

19.11.1 SPI (serial peripheral interface)

Subject to general operating conditions for V_{DD} , f_{CPU} , and T_A unless otherwise specified.

Refer to [Section 19.8: I/O port pin characteristics](#) for more details on the input/output alternate function characteristics (\overline{SS} , SCK, MOSI, MISO).

Table 132. SPI characteristics

Symbol	Parameter	Conditions	Min	Max	Unit
f_{SCK} $1/t_{c(SCK)}$	SPI clock frequency	Master, $f_{CPU} = 8$ MHz	$f_{CPU}/128 = 0.0625$	$f_{CPU}/4 = 2$	MHz
		Slave, $f_{CPU} = 8$ MHz	0	$f_{CPU}/2 = 4$	
$t_{r(SCK)}$ $t_{f(SCK)}$	SPI clock rise and fall time		see I/O port pin description		
$t_{su(\overline{SS})}^{(1)}$	\overline{SS} setup time ⁽²⁾	Slave	$t_{CPU} + 50$		ns
$t_{h(\overline{SS})}^{(1)}$	\overline{SS} hold time	Slave	120		
$t_{w(SCKH)}^{(1)}$ $t_{w(SCKL)}^{(1)}$	SCK high and low time	Master	100		
		Slave	90		
$t_{su(MI)}^{(1)}$ $t_{su(SI)}^{(1)}$	Data input setup time	Master	100		
		Slave	100		
$t_{h(MI)}^{(1)}$ $t_{h(SI)}^{(1)}$	Data input hold time	Master	100		
		Slave	100		
$t_{a(SO)}^{(1)}$	Data output access time	Slave	0	120	
$t_{dis(SO)}^{(1)}$	Data output disable time	Slave		240	
$t_{v(SO)}^{(1)}$	Data output valid time	Slave (after enable edge)		120	
$t_{h(SO)}^{(1)}$	Data output hold time		0		
$t_{v(MO)}^{(1)}$	Data output valid time	Master (after enable edge)		120	
$t_{h(MO)}^{(1)}$	Data output hold time		0		t_{CPU}

1. Data based on design simulation and/or characterization results, not tested in production.

2. Depends on f_{CPU} . For example, if $f_{CPU} = 8$ MHz, then $t_{CPU} = 1 / f_{CPU} = 125$ ns and $t_{su(\overline{SS})} = 175$ ns.

Figure 93. SPI slave timing diagram with CPHA = 0⁽¹⁾

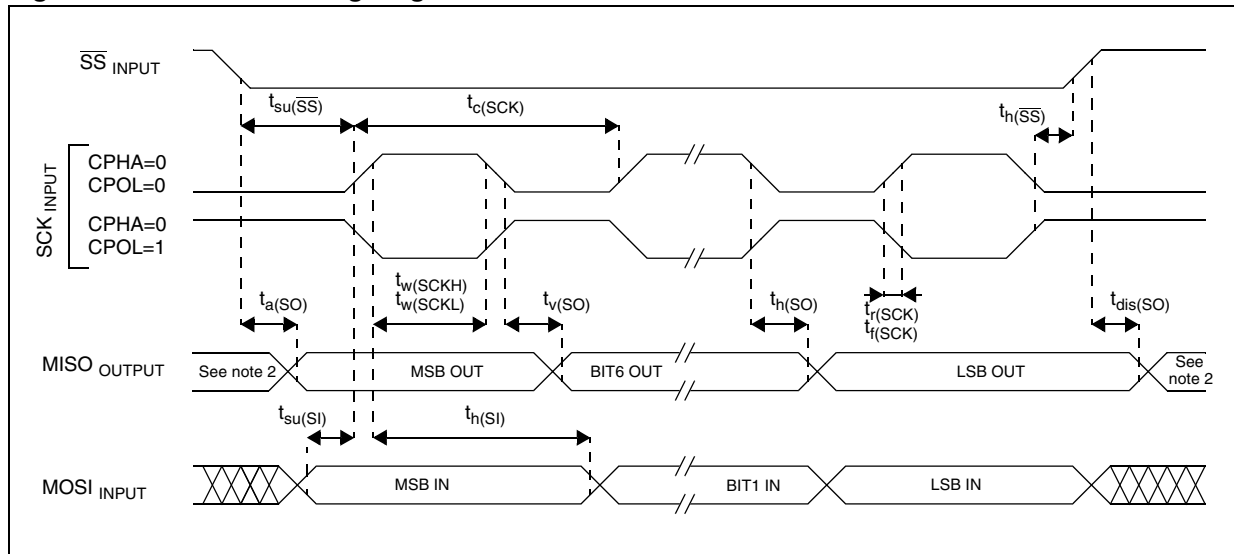

1. Measurement points are done at CMOS levels: $0.3 \times V_{DD}$ and $0.7 \times V_{DD}$.
2. When no communication is on-going the data output line of the SPI (MOSI in master mode, MISO in slave mode) has its alternate function capability released. In this case, the pin status depends on the I/O port configuration.

Figure 94. SPI slave timing diagram with CPHA = 1⁽¹⁾

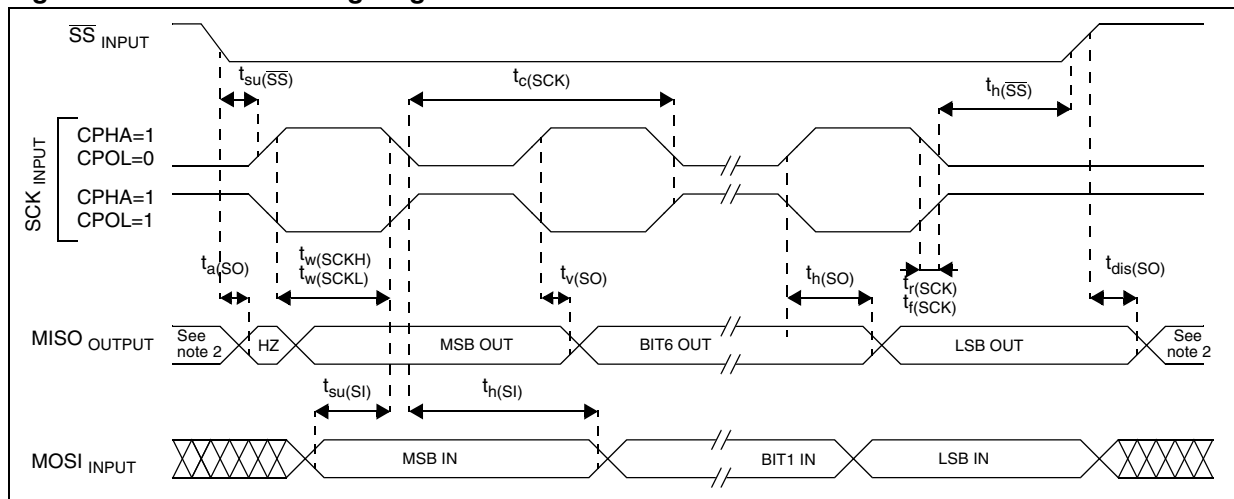

1. Measurement points are done at CMOS levels: $0.3 \times V_{DD}$ and $0.7 \times V_{DD}$.
2. When no communication is on-going the data output line of the SPI (MOSI in master mode, MISO in slave mode) has its alternate function capability released. In this case, the pin status depends of the I/O port configuration.

Figure 95. SPI master timing diagram⁽¹⁾

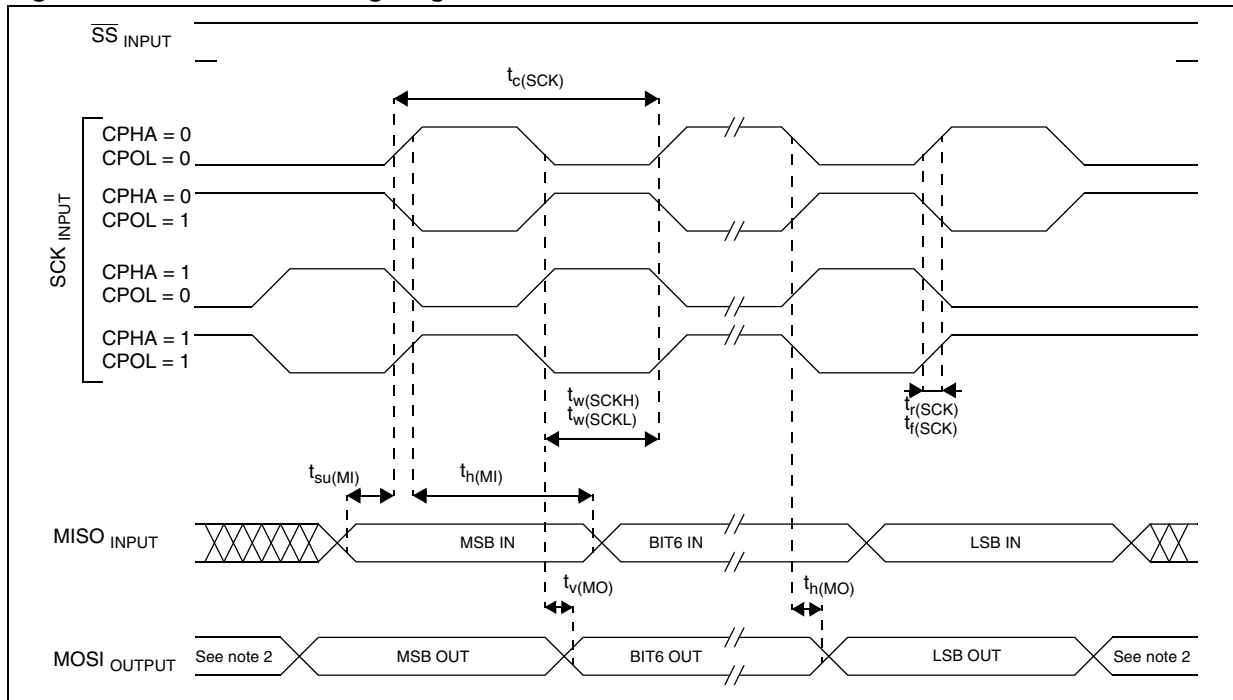

1. Measurement points are done at CMOS levels: $0.3 \times V_{DD}$ and $0.7 \times V_{DD}$.
2. When no communication is on-going the data output line of the SPI (MOSI in master mode, MISO in slave mode) has its alternate function capability released. In this case, the pin status depends of the I/O port configuration.

19.11.2 I²C - inter IC control interface

Subject to general operating conditions for V_{DD} , f_{CPU} , and T_A unless otherwise specified.

Refer to [Section 19.8: I/O port pin characteristics](#) for more details on the input/output alternate function characteristics (SDAI and SCLI). The ST7 I2C interface meets the requirements of the standard I2C communication protocol described in the following table.

Table 133. I²C control interface characteristics

Symbol	Parameter	Standard mode I ² C		Fast mode I ² C ⁽¹⁾		Unit
		Min ⁽²⁾	Max ⁽²⁾	Min ⁽²⁾	Max ⁽²⁾	
$t_{w(SCLL)}$	SCL clock low time	4.7		1.3		μ s
$t_{w(SCLH)}$	SCL clock high time	4.0		0.6		
$t_{su(SDA)}$	SDA setup time	250		100		ns
$t_h(SDA)$	SDA data hold time	0 ⁽³⁾		0 ⁽⁴⁾	900 ⁽³⁾	
$t_r(SDA)$ $t_r(SCL)$	SDA and SCL rise time		1000	20+0.1C _b	300	
$t_f(SDA)$ $t_f(SCL)$	SDA and SCL fall time		300			
$t_h(STA)$	START condition hold time	4.0		0.6		μ s
$t_{su(STA)}$	Repeated START condition setup time	4.7				
$t_{su(STO)}$	STOP condition setup time	4.0				
$t_w(STO:STA)$	STOP to START condition time (bus free)	4.7		1.3		
C _b	Capacitive load for each bus line		400		400	pF

- At 4 MHz f_{CPU} , maximum I²C speed (400 kHz) is not achievable. In this case, maximum I²C speed will be approximately 260 kHz.
- Data based on standard I²C protocol requirement, not tested in production.
- The maximum hold time of the START condition has only to be met if the interface does not stretch the low period of SCL signal.
- The device must internally provide a hold time of at least 300ns for the SDA signal in order to bridge the undefined region of the falling edge of SCL.

Figure 96. Typical application with I²C BUS and timing diagram⁽¹⁾

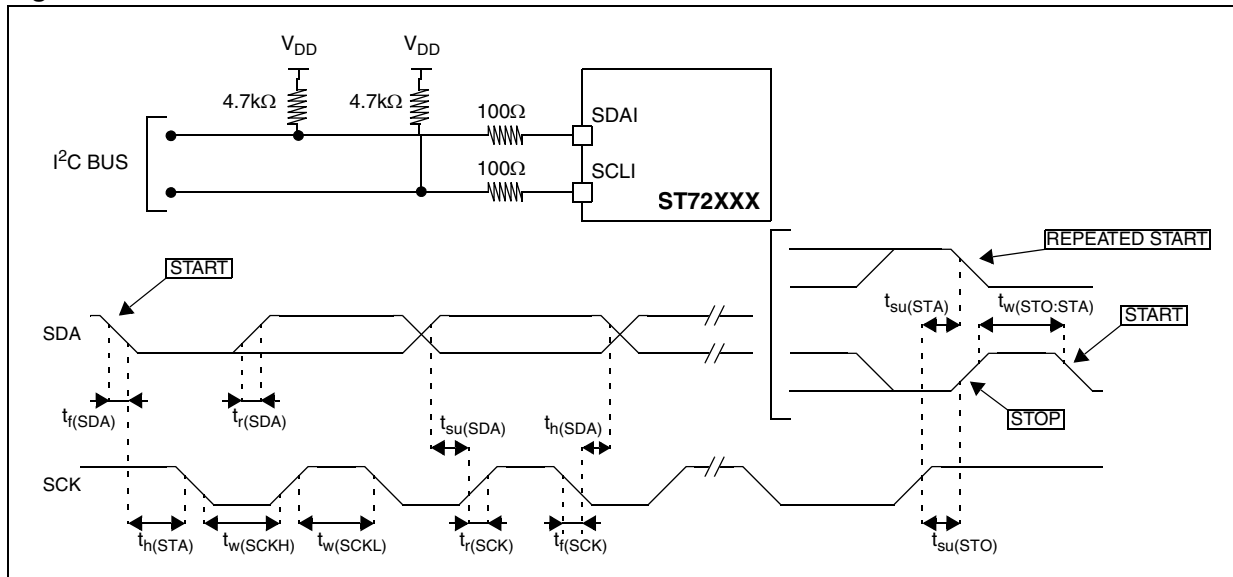

1. Measurement points are done at CMOS levels: $0.3 \times V_{DD}$ and $0.7 \times V_{DD}$.

The following table provides the values to be written in the I2CCCR register to obtain the required I²C SCL line frequency.

Table 134. SCL frequency table

f _{SCL} (kHz)	I2CCCR value							
	f _{CPU} = 4 MHz				f _{CPU} = 8 MHz			
	V _{DD} = 4.1V		V _{DD} = 5V		V _{DD} = 4.1V		V _{DD} = 5V	
	R _p = 3.3kΩ	R _p = 4.7kΩ	R _p = 3.3kΩ	R _p = 4.7kΩ	R _p = 3.3kΩ	R _p = 4.7kΩ	R _p = 3.3kΩ	R _p = 4.7kΩ
400	Not achievable				83h			
300	Not achievable				85h			
200	83h				8Ah	89h	8Ah	
100	10h				24h	23h	24h	23h
50	24h				4Ch			
20	5Fh				FFh			

Legend:

R_p = External pull-up resistance

f_{SCL} = I²C speed

Note: - For speeds around 200 kHz, the achieved speed can have a ±5% tolerance.
 - For other speed ranges, the achieved speed can have a ±2% tolerance.

The above variations depend on the accuracy of the external components used.

19.12 10-bit ADC characteristics

Subject to general operating conditions for V_{DD} , f_{CPU} , and T_A unless otherwise specified.

Table 135. 10-bit ADC characteristics

Symbol	Parameter	Conditions	Min	Typ	Max	Unit
f_{ADC}	ADC clock frequency		0.4		2	MHz
V_{AREF}	Analog reference voltage	$0.7 \cdot V_{DD} \leq V_{AREF} \leq V_{DD}$	3.8		V_{DD}	V
V_{AIN}	Conversion voltage range ⁽¹⁾		V_{SSA}		V_{AREF}	
I_{lkg}	Positive input leakage current for analog input	$-40^\circ\text{C} \leq T_A \leq 85^\circ\text{C}$ range			± 250	nA
		Other T_A ranges			± 1	μA
I_{lkg}	Negative input leakage current on robust analog pins ⁽²⁾	$V_{IN} < V_{SS}$, $ I_{IN} < 400\mu\text{A}$ on adjacent robust analog pin		5	6	μA
R_{AIN}	External input impedance ⁽³⁾				See Figure 97 and Figure 98	k Ω
C_{AIN}	External capacitor on analog input					pF
f_{AIN}	Variation frequency of analog input signal					Hz
C_{ADC}	Internal sample and hold capacitor			12		pF
t_{ADC}	Conversion time (Sample + Hold) $f_{CPU} = 8 \text{ MHz}$, speed = 0, $f_{ADC} = 2 \text{ MHz}$			7.5		μs
t_{ADC}	No. of sample capacitor loading cycles			4		$1/f_{ADC}$
	No. of hold conversion cycles			11		

- Any added external serial resistor will downgrade the ADC accuracy (especially for resistance greater than 10k Ω). Data based on characterization results, not tested in production.
- Injecting negative current on any of the analog input pins significantly reduces the accuracy of any conversion being performed on any analog input. Analog pins of Flash devices can be protected against negative injection by adding a Schottky diode (pin to ground). Injecting negative current on digital input pins degrades ADC accuracy especially if performed on a pin close to the analog input pins. Any positive injection current within the limits specified for $I_{INJ(PIN)}$ and $\Sigma I_{INJ(PIN)}$ in [Section 19.8](#) does not affect the ADC accuracy.
- Any added external serial resistor will downgrade the ADC accuracy (especially for resistance greater than 10k Ω). Data based on characterization results, not tested in production.

Figure 97. R_{AIN} maximum versus f_{ADC} with $C_{AIN} = 0pF^{(1)}$

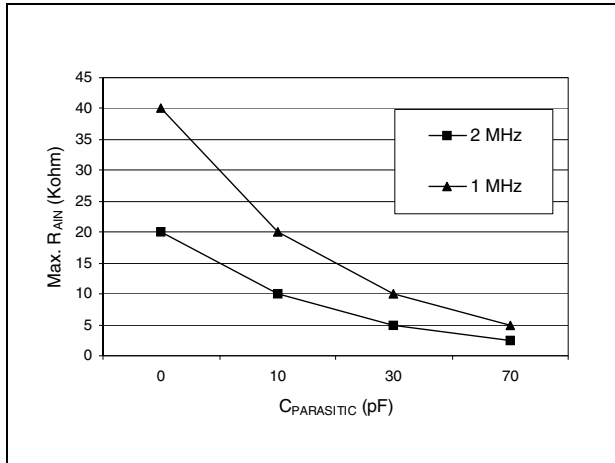

1. $C_{PARASITIC}$ represents the capacitance of the PCB (dependent on soldering and PCB layout quality) plus the pad capacitance (3pF). A high $C_{PARASITIC}$ value will downgrade conversion accuracy. To remedy this, f_{ADC} should be reduced.

Figure 98. Recommended C_{AIN} and R_{AIN} values⁽¹⁾

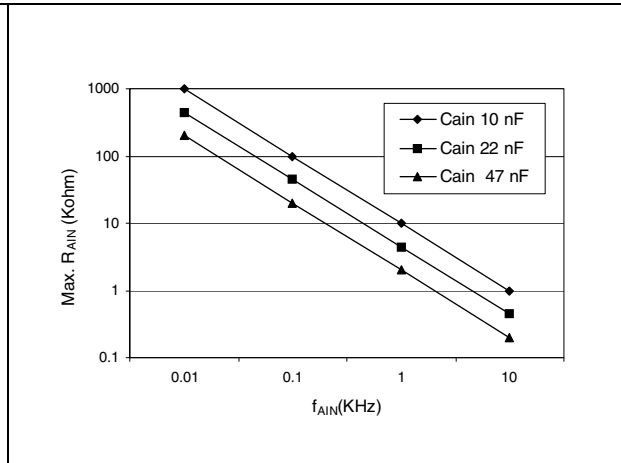

1. This graph shows that, depending on the input signal variation (f_{AIN}), C_{AIN} can be increased for stabilization time and decreased to allow the use of a larger serial resistor (R_{AIN}).

Figure 99. Typical A/D converter application

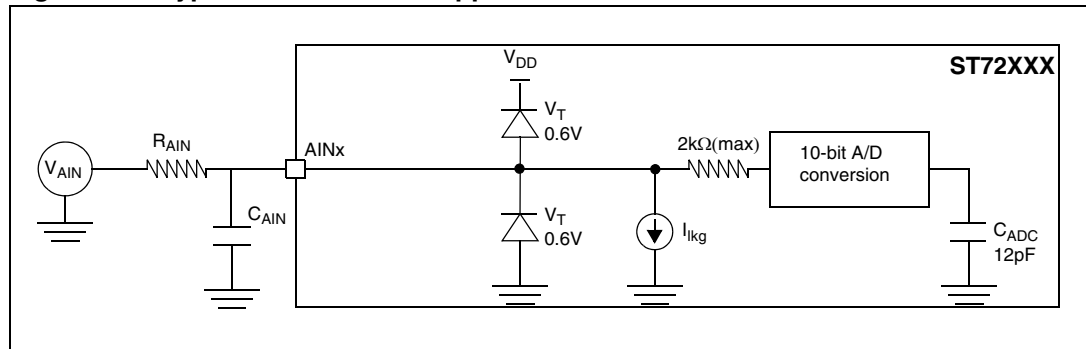

19.12.1 Analog power supply and reference pins

Depending on the MCU pin count, the package may feature separate V_{AREF} and V_{SSA} analog power supply pins. These pins supply power to the A/D converter cell and function as the high and low reference voltages for the conversion.

Separation of the digital and analog power pins allow board designers to improve A/D performance. Conversion accuracy can be impacted by voltage drops and noise in the event of heavily loaded or badly decoupled power supply lines (see [Section 19.12.2: General PCB design guidelines](#)).

19.12.2 General PCB design guidelines

To obtain best results, some general design and layout rules should be followed when designing the application PCB to shield the noise-sensitive, analog physical interface from noise-generating CMOS logic signals.

- Use separate digital and analog planes. The analog ground plane should be connected to the digital ground plane via a single point on the PCB.
- Filter power to the analog power planes. It is recommended to connect capacitors, with good high frequency characteristics, between the power and ground lines, placing $0.1\mu\text{F}$ and optionally, if needed 10pF capacitors as close as possible to the ST7 power supply pins and a 1 to $10\mu\text{F}$ capacitor close to the power source (see [Figure 100](#)).
- The analog and digital power supplies should be connected in a star network. Do not use a resistor, as V_{AREF} is used as a reference voltage by the A/D converter and any resistance would cause a voltage drop and a loss of accuracy.
- Properly place components and route the signal traces on the PCB to shield the analog inputs. Analog signals paths should run over the analog ground plane and be as short as possible. Isolate analog signals from digital signals that may switch while the analog inputs are being sampled by the A/D converter. Do not toggle digital outputs on the same I/O port as the A/D input being converted.

Figure 100. Power supply filtering

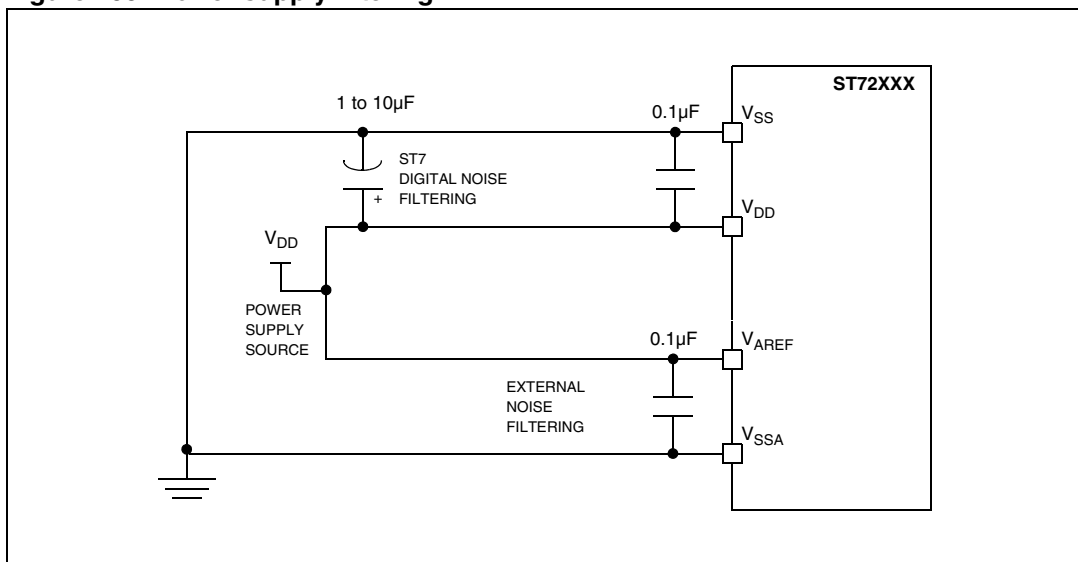

19.12.3 ADC accuracy

Conditions: $V_{DD} = 5V^{(1)}$

Table 136. ADC accuracy

Symbol	Parameter ⁽¹⁾	Conditions	Typ	Max ⁽²⁾	Unit
$ E_T $	Total unadjusted error	CPU in run mode @ f_{ADC} 2 MHz	3	4	LSB
$ E_O $	Offset error		2	3	
$ E_G $	Gain error		0.5	3	
$ E_D $	Differential linearity error		1	2	
$ E_L $	Integral linearity error				

- ADC Accuracy versus Negative Injection Current: Injecting negative current may reduce the accuracy of the conversion being performed on another analog input. Any positive injection current within the limits specified for $I_{INJ(PIN)}$ and $\Sigma I_{INJ(PIN)}$ in [Section 19.8](#) does not affect the ADC accuracy.
- Data based on characterization results, monitored in production to guarantee 99.73% within \pm max value from -40°C to 125°C ($\pm 3\sigma$ distribution limits).

Figure 101. ADC error classification

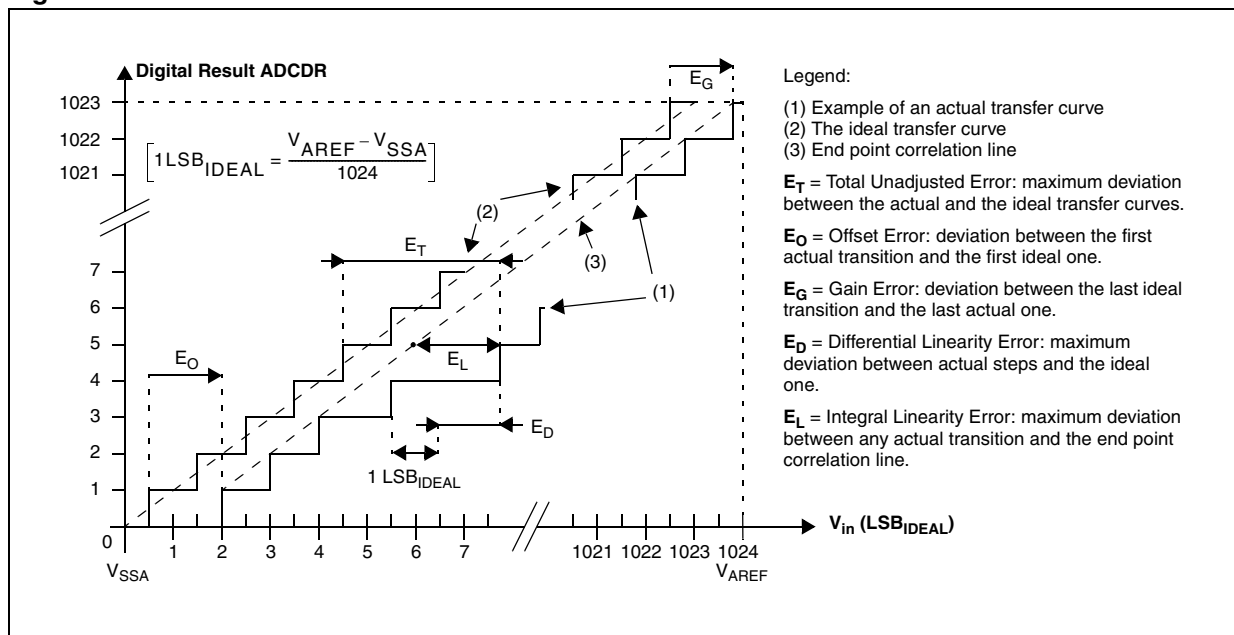

20 Package characteristics

Figure 102. 64-pin (14x14) low profile quad flat package outline

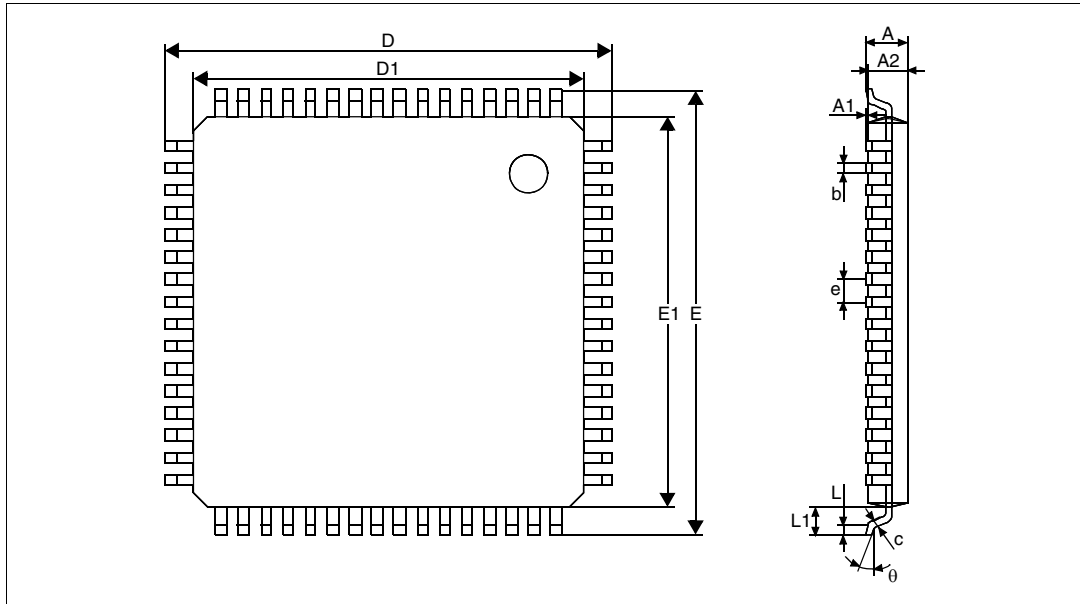

Table 137. 64-pin (14x14) low profile quad flat package mechanical data

Dimension	mm			inches		
	Min	Typ	Max	Min	Typ	Max
A			1.600			0.0630
A1	0.050		0.150	0.0020		0.0059
A2	1.350	1.400	1.450	0.0531	0.0551	0.0571
b	0.300	0.370	0.450	0.0118	0.0146	0.0177
c	0.090		0.200	0.0035		0.0079
D		16.000			0.6299	
D1		14.000			0.5512	
E		16.000			0.6299	
E1		14.000			0.5512	
e		0.800			0.0315	
θ	0°	3.5°	7°	0°	3.5°	7°
L	0.450	0.600	0.750	0.0177	0.0236	0.0295
L1		1.000			0.0394	

Figure 103. 64-pin (10x10) low profile quad flat package outline

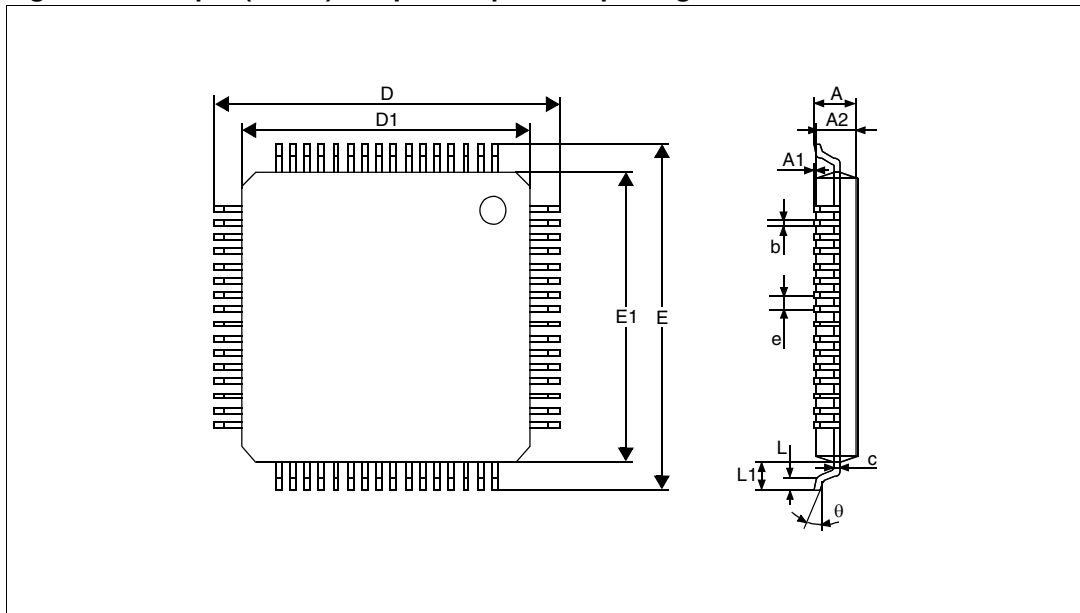

Table 138. 64-pin (10x10) low profile quad flat package mechanical data

Dimension	mm			inches		
	Min	Typ	Max	Min	Typ	Max
A			1.600			0.0630
A1	0.050		0.150	0.0020		0.0059
A2	1.350	1.400	1.450	0.0531	0.0551	0.0571
b	0.170	0.220	0.270	0.0067	0.0087	0.0106
c	0.090		0.200	0.0035		0.0079
D		12.000			0.4724	
D1		10.000			0.3937	
E		12.000			0.4724	
E1		10.000			0.3937	
e		0.500			0.0197	
θ	0°	3.5°	7°	0°	3.5°	7°
L	0.450	0.600	0.750	0.0177	0.0236	0.0295
L1		1.000			0.0394	

20.1 Thermal characteristics

Table 139. Thermal characteristics

Symbol	Ratings	Value	Unit
R _{thJA}	Package thermal resistance (junction to ambient)	47	°C/W
	LQFP64 14x14	50	
	LQFP64 10x10	52	
	LQFP44 10x10		
P _D	Power dissipation ⁽¹⁾	500	mW
T _{Jmax}	Maximum junction temperature ⁽²⁾	150	°C

1. The maximum power dissipation is obtained from the formula $P_D = (T_J - T_A) / R_{thJA}$. The power dissipation of an application can be defined by the user with the formula: $P_D = P_{INT} + P_{PORT}$ where P_{INT} is the chip internal power ($I_{DD} \times V_{DD}$) and P_{PORT} is the port power dissipation depending on the ports used in the application.
2. The maximum chip-junction temperature is based on technology characteristics.

20.2 Ecopack information

In order to meet environmental requirements, ST offers these devices in different grades of ECOPACK® packages, depending on their level of environmental compliance. ECOPACK® specifications, grade definitions and product status are available at: www.st.com. ECOPACK® is an ST trademark.

20.3 Packaging for automatic handling

The devices can be supplied in trays or with tape and reel conditioning.

Tape and reel conditioning can be ordered with pin 1 left-oriented or right-oriented when facing the tape sprocket holes as shown in [Figure 104](#).

Figure 104. Pin 1 orientation in tape and reel conditioning

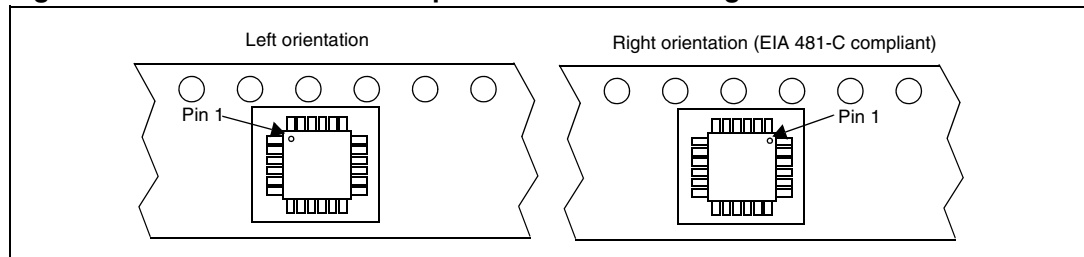

See also [Section Figure 105.: ST72F321xxx-Auto Flash commercial product structure on page 226](#) and [Figure 106: ST72P321xxx-Auto FastROM commercial product structure on page 228](#).

21 Device configuration and ordering information

Each device is available for production in user programmable versions (Flash) as well as in factory coded versions (ROM/FASTROM).

ST72321-Auto devices are ROM versions, ST72P321-Auto devices are Factory Advanced Service Technique ROM (FASTROM) versions: They are factory-programmed HDFlash devices. Flash devices are shipped to customers with a default content, whereas ROM/FASTROM factory coded parts contain the code supplied by the customer. This implies that Flash devices have to be configured by the customer using the option bytes while the ROM/FASTROM devices are factory-configured.

Detailed device configuration and ordering information is presented in the following [Section 21.1: Flash devices](#) and [Section 21.2: ROM device ordering information and transfer of customer code](#).

21.1 Flash devices

21.1.1 Flash configuration

Table 140. Flash option bytes

	Static option byte 0								Static option byte 1							
	7	6	5	4	3	2	1	0	7	6	5	4	3	2	1	0
	WDG		Res	VD		Res	PKG0	FMP_R	PKG1	RSTC	OSCTYPE		OSCRANGE			PLLOFF
HALT	SW	1		0	1						0	2	1	0		
Default value:	1	1	1	0	0	1	1	1	1	1	1	0	1	1	1	1

The option bytes allow the hardware configuration of the microcontroller to be selected. They have no address in the memory map and can be accessed only in programming mode (for example, using a standard ST7 programming tool). The default content of the Flash is fixed to FFh. To program the Flash devices directly using ICP, Flash devices are shipped to customers with the internal RC clock source enabled. In masked ROM devices, the option bytes are fixed in hardware by the ROM code (see option list).

Table 141. Option byte 0 bit description

Bit	Name	Function
OPT7	WDG HALT	<p>Watchdog and Halt mode</p> <p>This option bit determines if a RESET is generated when entering Halt mode while the Watchdog is active.</p> <p>0: No Reset generation when entering Halt mode 1: Reset generation when entering Halt mode</p>
OPT6	WDG SW	<p>Hardware or software watchdog</p> <p>This option bit selects the watchdog type.</p> <p>0: Hardware (watchdog always enabled) 1: Software (watchdog to be enabled by software)</p>
OPT5	-	Reserved, must be kept at default value.
OPT4:3	VD[1:0]	<p>Voltage detection</p> <p>These option bits enable the voltage detection block (LVD and AVD) with a selected threshold for the LVD and AVD (EVD + AVD).</p> <p>00: Selected LVD = Highest threshold ($V_{DD} - 4V$) 01: Selected LVD = Medium threshold ($V_{DD} - 3.5V$) 10: Selected LVD = Lowest threshold ($V_{DD} - 3V$) 11: LVD and AVD off</p> <p>Caution: If the medium or low thresholds are selected, the detection may occur outside the specified operating voltage range. Below 3.8V, device operation is not guaranteed. For details on the AVD and LVD threshold levels refer to Table 19.3.2: Operating conditions with low voltage detector (LVD).</p>
OPT2	-	Reserved, must be kept at default value.
OPT1	PKG0	<p>Package selection bit 0</p> <p>This option bit is used with the PKG1 bit to select the package (see Table 143: Package selection (OPT7)).</p>
OPT0	FMP_R	<p>Flash memory readout protection</p> <p>Readout protection, when selected, provides a protection against program memory content extraction and against write access to Flash memory.</p> <p>Erasing the option bytes when the FMP_R option is selected causes the whole user memory to be erased first, after which the device can be reprogrammed. Refer to Section 4.3.1: Readout protection on page 30 and the <i>ST7 Flash Programming Reference Manual</i> for more details.</p> <p><i>Note: Readout protection is not supported if LVD is enabled.</i></p> <p>0: Readout protection enabled 1: Readout protection disabled</p>

Table 142. Option byte 1 bit description

Bit	Name	Function
OPT7	PKG1	Package selection bit 1 This option bit, with the PKG0 bit, selects the package (see Table 143: Package selection (OPT7)).
OPT6	RSTC	RESET clock cycle selection This option bit selects the number of CPU cycles applied during the RESET phase and when exiting Halt mode. For resonator oscillators, it is advised to select 4096 due to the long crystal stabilization time. 0: Reset phase with 4096 CPU cycles 1: Reset phase with 256 CPU cycles
OPT5:4	OSCTYPE[1:0]	Oscillator type These option bits select the ST7 main clock source type. 00: Clock source = Resonator oscillator 01: Reserved 10: Clock source = Internal RC oscillator 11: Clock source = External source
OPT3:1	OSCRANGE[2:0]	Oscillator range When the resonator oscillator type is selected, these option bits select the resonator oscillator current source corresponding to the frequency range of the resonator used. Otherwise, these bits are used to select the normal operating frequency range. 000: Typ. frequency range = LP (1 ~ 2 MHz) 001: Typ. frequency range = MP (2 ~ 4 MHz) 010: Typ. frequency range = MS (4 ~ 8 MHz) 011: Typ. frequency range = HS (8 ~ 16 MHz)
OPT0	PLLOFF	PLL activation This option bit activates the PLL which allows multiplication by two of the main input clock frequency. The PLL must not be used with the internal RC oscillator or with external clock source. The PLL is guaranteed only with an input frequency between 2 and 4 MHz. 0: PLL x2 enabled 1: PLL x2 disabled Caution: The PLL can be enabled only if the OSCRANGE (OPT3:1) bits are configured to "MP 2 ~ 4 MHz". Otherwise, the device functionality is not guaranteed.

Table 143. Package selection (OPT7)

Version	Selected package	PKG1	PKG0
(A)R	LQFP64	1	0
J	LQFP44	0	0

Note: On the chip, each I/O port has up to eight pads. Pads that are not bonded to external pins are in input pull-up configuration after reset. The configuration of these pads must be kept at reset state to avoid added current consumption.

21.1.2 Flash ordering information

The following *Figure 105* serves as a guide for ordering.

Figure 105. ST72F321xxx-Auto Flash commercial product structure

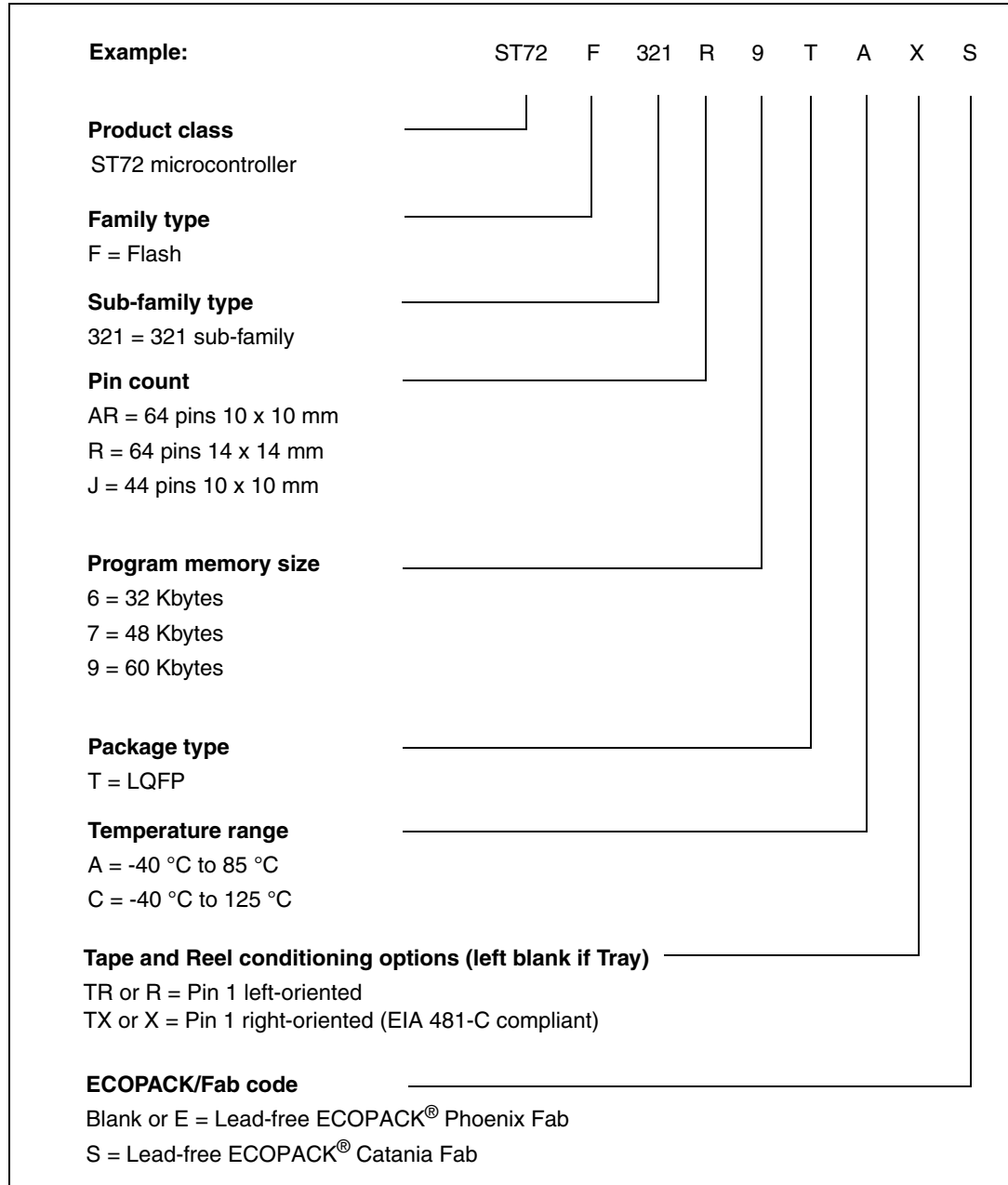

1. For a list of available options (e.g. memory size, package) and orderable part numbers or for further information on any aspect of this device, please go to www.st.com or contact the ST Sales Office nearest to you.

21.2 ROM device ordering information and transfer of customer code

Customer code is made up of the ROM/FASTROM contents and the list of the selected options (if any). The ROM/FASTROM contents are to be sent on diskette, or by electronic means, with the S19 hexadecimal file generated by the development tool. All unused bytes must be set to FFh.

Complete the appended **Option list** [on page 230](#) to communicate the selected options to STMicroelectronics and check for regular updates of the option list on the ST website or ask your ST representative.

Refer to application note AN1635 for information on the counter listing returned by ST after code has been transferred.

The following [Figure 106](#) and [Figure 107](#) serve as guides for ordering. The STMicroelectronics Sales Organization will be pleased to provide detailed information on contractual points.

Caution: The Readout Protection binary value is inverted between ROM and Flash products. The option byte checksum will differ between ROM and Flash.

Figure 106. ST72P321xxx-Auto FastROM commercial product structure

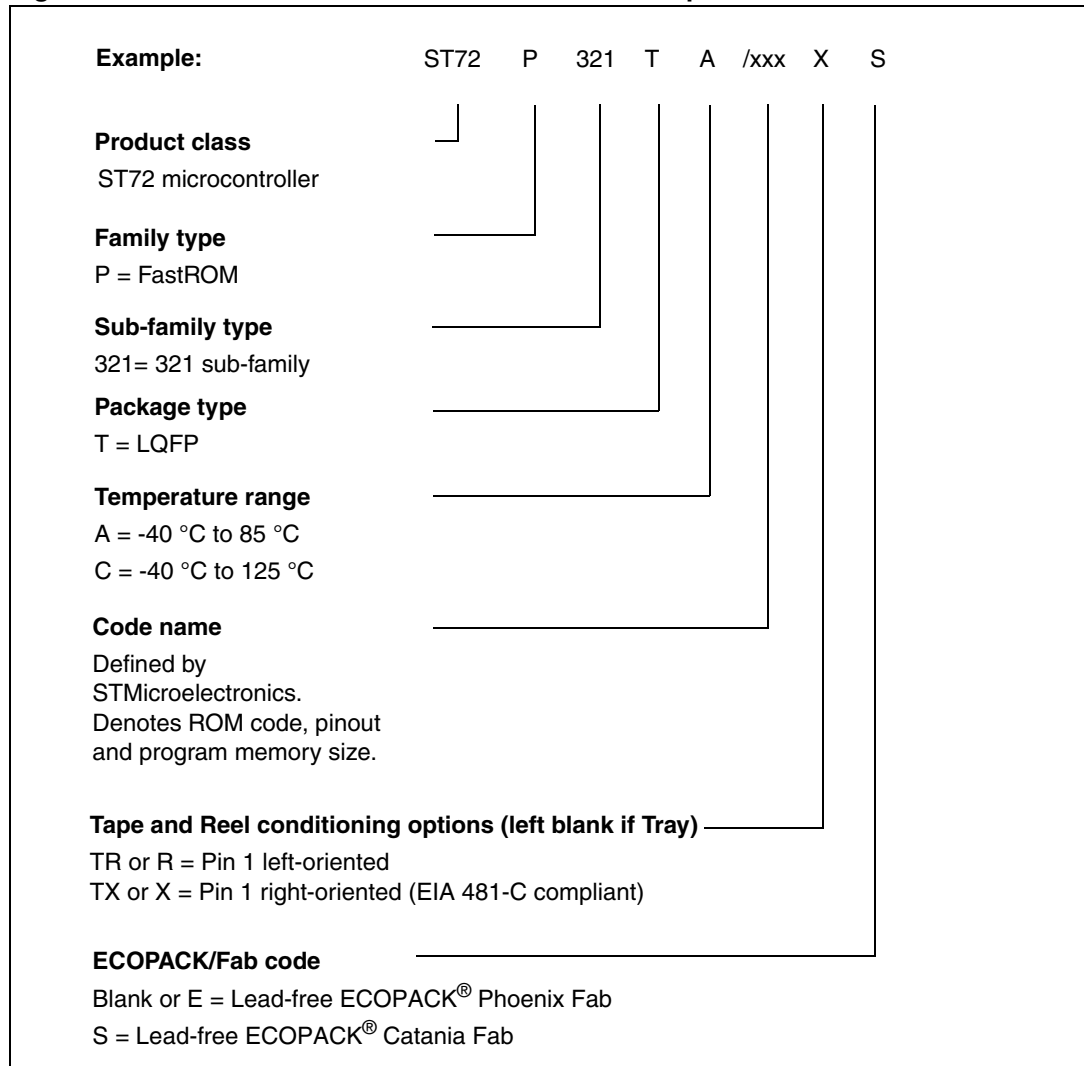
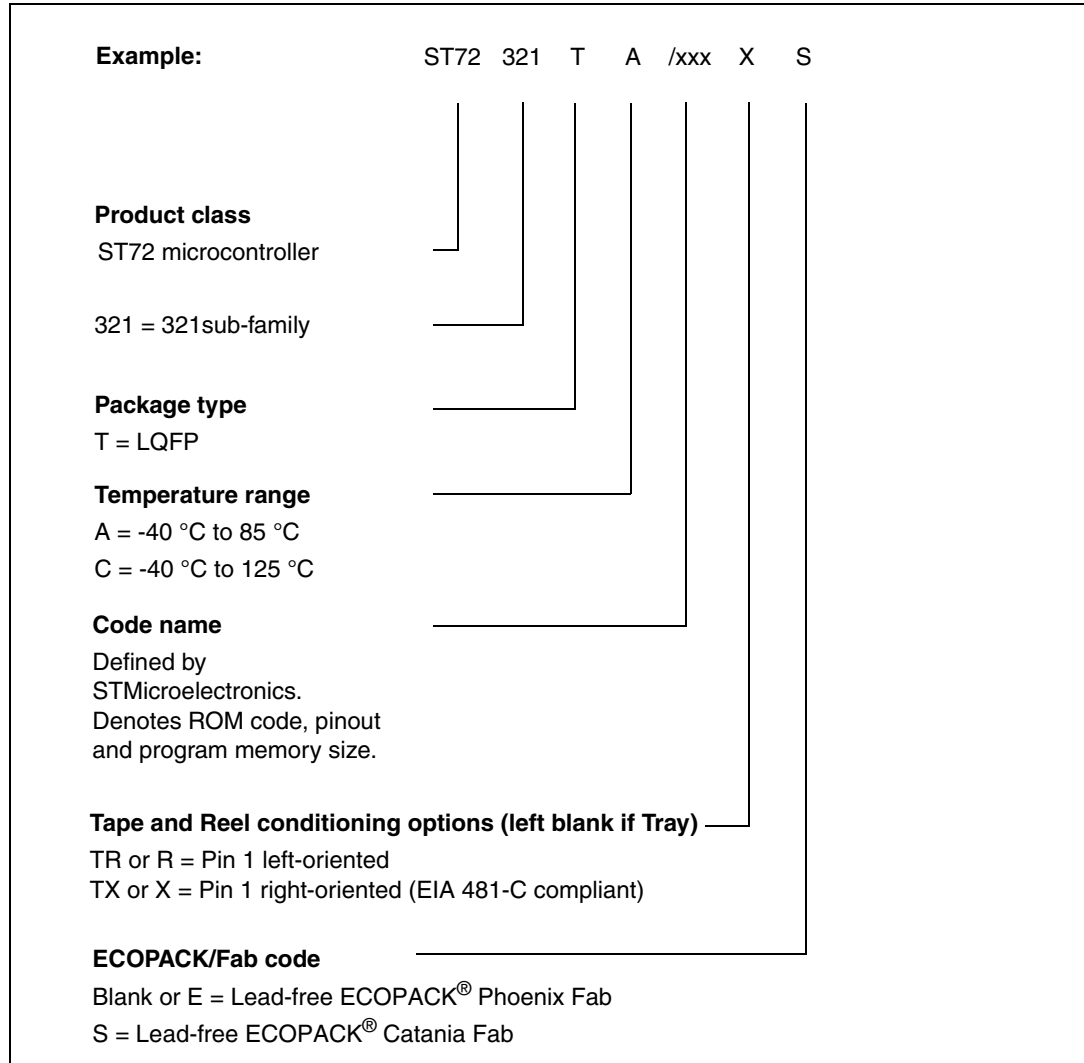

Figure 107. ST72321xxx-Auto ROM commercial product structure



21.3 Development tools

21.3.1 Introduction

Development tools for the ST7 microcontrollers include a complete range of hardware systems and software tools from STMicroelectronics and third-party tool suppliers. The range of tools includes solutions to help you evaluate microcontroller peripherals, develop and debug your application, and program your microcontrollers.

21.3.2 Evaluation tools and starter kits

ST offers complete, affordable starter kits and full-featured evaluation boards that allow you to evaluate microcontroller features and quickly start developing ST7 applications. Starter kits are complete, affordable hardware/software tool packages that include features and samples to help you quickly start developing your application. ST evaluation boards are open-design, embedded systems, which are developed and documented to serve as references for your application design. They include sample application software to help you demonstrate, learn about and implement your ST7's features.

21.3.3 Development and debugging tools

Application development for ST7 is supported by fully optimizing C Compilers and the ST7 Assembler-Linker toolchain, which are all seamlessly integrated in the ST7 integrated development environments in order to facilitate the debugging and fine-tuning of your application. The Cosmic C Compiler is available in a free version that outputs up to 16 Kbytes of code.

The range of hardware tools includes cost effective ST7-DVP3 series emulators. These tools are supported by the ST7 Toolset from STMicroelectronics, which includes the STVD7 integrated development environment (IDE) with high-level language debugger, editor, project manager and integrated programming interface.

21.3.4 Programming tools

During the development cycle, the ST7-DVP3 and ST7-EMU3 series emulators and the RLink provide in-circuit programming capability for programming the Flash microcontroller on your application board.

ST also provides a low-cost dedicated in-circuit programmer, the ST7-STICK, as well as ST7 socket boards which provide all the sockets required for programming any of the devices in a specific ST7 subfamily on a platform that can be used with any tool with in-circuit programming capability for ST7.

For production programming of ST7 devices, ST's third-party tool partners also provide a complete range of gang and automated programming solutions, which are ready to integrate into your production environment.

For additional ordering codes for spare parts, accessories and tools available for the ST7 (including from third party manufacturers), refer to the online product selector at www.st.com/mcu.

Table 144. STMicroelectronics development tools

Supported products	Emulation				Programming
	ST7 DVP3 series		ST7 EMU3 series		ICC socket board
	Emulator	Connection kit	Emulator	Active probe and T.E.B.	
ST72521M, ST72F521M	ST7MDT20-DVP3	ST7MDT20-T80/DVP	ST7MDT20M-EMU3	ST7MDT20M-TEB	ST7SB20M/xx ⁽¹⁾
ST72521R, ST72F521R		ST7MDT20-T64/DVP			
ST72521AR, ST72F521AR		ST7MDT20-T6A/DVP			
ST72321AR, ST72F321AR	ST7MDT20-DVP3	ST7MDT20-T6A/DVP	ST7MDT20M-EMU3	ST7MDT20M-TEB	ST7SB20M/xx ⁽²⁾
ST72321R, ST72F321R		ST7MDT20-T64/DVP			
ST72321J, ST72F321J		ST7MDT20-T44/DVP			

1. Add suffix /EU, /UK, /US for the power supply of your region.
2. Add suffix /EU, /UK, /US for the power supply of your region.

Table 145. Suggested list of socket types

Device	Socket (supplied with ST7MDT20M-EMU3)	Emulator adapter (supplied with ST7MDT20M-EMU3)
LQFP80 14 X 14	YAMAICHI IC149-080-*51-*5	YAMAICHI ICP-080-7
LQFP64 14 x14	CAB 3303262	CAB 3303351
LQFP64 10 x10	YAMAICHI IC149-064-*75-*5	YAMAICHI ICP-064-6
LQFP44 10 x10	YAMAICHI IC149-044-*52-*5	YAMAICHI ICP-044-5

21.3.5 Socket and emulator adapter information

For information on the type of socket that is supplied with the emulator, refer to the suggested list of sockets in [Table 145](#).

Note: Before designing the board layout, it is recommended to check the overall dimensions of the socket as they may be greater than the dimensions of the device.

For footprint and other mechanical information about these sockets and adapters, refer to the manufacturer’s datasheet.

Related documentation

ST7 Visual Develop Software Key Debugging Features (AN 978)

ST7 Visual Develop for ST7 Cosmic C toolset users (AN 1938)

ST7 Visual Develop for ST7 Assembler Linker toolset users (AN 1940)

21.4 ST7 application notes

All relevant ST7 application notes can be found on www.st.com.

22 Known limitations

22.1 All Flash and ROM devices

22.1.1 External RC option

The external RC clock source option described in previous datasheet revisions is no longer supported and has been removed from this specification.

22.1.2 Safe connection of OSC1/OSC2 pins

The OSC1 and/or OSC2 pins must not be left unconnected, otherwise the ST7 main oscillator may start and, in this configuration, could generate an f_{OSC} clock frequency in excess of the allowed maximum (> 16 MHz), putting the ST7 in an unsafe/undefined state. Refer to [Section 6.4: Multi-oscillator \(MO\) on page 38](#).

22.1.3 Reset pin protection with LVD enabled

As mentioned in [Note 2](#) below [Figure 90: RESET pin protection when LVD is enabled on page 208](#), when the LVD is enabled, it is recommended not to connect a pull-up resistor or capacitor. A 10nF pull-down capacitor is required to filter noise on the reset line.

22.1.4 Unexpected reset fetch

If an interrupt request occurs while a “POP CC” instruction is executed, the interrupt controller does not recognize the source of the interrupt and, by default, passes the RESET vector address to the CPU.

Workaround

To solve this issue, a “POP CC” instruction must always be preceded by a “SIM” instruction.

22.1.5 External interrupt missed

To avoid any risk of generating a parasitic interrupt, the edge detector is automatically disabled for one clock cycle during an access to either DDR and OR. Any input signal edge during this period will not be detected and will not generate an interrupt.

This case can typically occur if the application refreshes the port configuration registers at intervals during runtime.

Workaround

The workaround is based on software checking the level on the interrupt pin before and after writing to the PxOR or PxDDR registers. If there is a level change (depending on the sensitivity programmed for this pin) the interrupt routine is invoked using the call instruction with three extra PUSH instructions before executing the interrupt routine (this is to make the call compatible with the IRET instruction at the end of the interrupt service routine).

But detection of the level change does not make sure that edge occurs during the critical 1 cycle duration and the interrupt has been missed. This may lead to occurrence of same interrupt twice (one hardware and another with software call).

To avoid this, a semaphore is set to '1' before checking the level change. The semaphore is changed to level '0' inside the interrupt routine. When a level change is detected, the semaphore status is checked. If it is '1', it means that the last interrupt has been missed. In this case, the interrupt routine is invoked with the call instruction.

There is another possible case, that is, if PxOR or PxDDR are written to with global interrupts disabled (interrupt mask bit set). In this case, the semaphore is changed to '1' when the level change is detected. Detecting a missed interrupt is done after the global interrupts are enabled (interrupt mask bit reset) and by checking the status of the semaphore. If it is '1', it means that the last interrupt was missed and the interrupt routine is invoked with the call instruction.

To implement the workaround, the following software sequence is to be followed for writing into the PxOR/PxDDR registers. The example is for Port PF1 with falling edge interrupt sensitivity. The software sequence is given for both cases (global interrupts disabled / global interrupts enabled):

Case 1: Writing to PxOR or PxDDR with global interrupts enabled:

```
LD A, #01

LD sema, A
; set the semaphore to '1'
LD A, PFDR

AND A, #02

LD X, A
; store the level before writing to PxOR/PxDDR
LD A, #$90

LD PFDDR, A
; Write to PFDDR
LD A, #$ff

LD PFOR, A
; Write to PFOR
LD A, PFDR

AND A, #02

LD Y, A
; store the level after writing to PxOR/PxDDR
LD A, X
; check for falling edge
cp A, #02

jrne OUT

TNZ Y

jrne OUT

LD A, sema
```

```
; check the semaphore status if edge is detected
CP A,#01

jrne OUT

call call_routine
; call the interrupt routine
OUT:LD A,#00

LD sema,A

.call_routine
; entry to call_routine
PUSH A

PUSH X

PUSH CC

.ext1_rt
; entry to interrupt routine
LD A,#00

LD sema,A

IRET
```

Case 2: Writing to PxOR or PxDDR with global interrupts disabled:

```
SIM
; set the interrupt mask
LD A,PFDR

AND A,#$02

LD X,A
; store the level before writing to PxOR/PxDDR
LD A,#$90

LD PFDDR,A
; Write into PFDDR
LD A,$ff

LD PFOR,A
; Write to PFOR
LD A,PFDR

AND A,$02

LD Y,A
; store the level after writing to PxOR/PxDDR
LD A,X
```

```
; check for falling edge
cp A,#$02

jrne OUT

TNZ Y

jrne OUT

LD A,#$01

LD sema,A
; set the semaphore to '1' if edge is detected
RIM
; reset the interrupt mask
LD A,sema
; check the semaphore status
CP A,#$01

jrne OUT

call call_routine
; call the interrupt routine
RIM

OUT:
RIM
JP while_loop

.call_routine
; entry to call_routine
PUSH A

PUSH X

PUSH CC

.ext1_rt
; entry to interrupt routine
LD A,#$00

LD sema,A

IRET
```

22.1.6 Clearing active interrupts outside interrupt routine

When an active interrupt request occurs at the same time as the related flag is being cleared, an unwanted reset may occur.

Note: Clearing the related interrupt mask will not generate an unwanted reset.

Concurrent interrupt context

The symptom does not occur when the interrupts are handled normally, that is, when:

- The interrupt flag is cleared within its own interrupt routine
- The interrupt flag is cleared within any interrupt routine
- The interrupt flag is cleared in any part of the code while this interrupt is disabled

If these conditions are not met, the symptom can be avoided by implementing the following sequence:

Perform SIM and RIM operation before and after resetting an active interrupt request.

Example:

```
SIM
Reset interrupt flag
RIM
```

Nested interrupt context

The symptom does not occur when the interrupts are handled normally, that is, when:

- The interrupt flag is cleared within its own interrupt routine
- The interrupt flag is cleared within any interrupt routine with higher or identical priority level
- The interrupt flag is cleared in any part of the code while this interrupt is disabled

If these conditions are not met, the symptom can be avoided by implementing the following sequence:

```
PUSH CC
SIM
Reset interrupt flag
POP CC
```

22.1.7 SCI wrong break duration

Description

A single break character is sent by setting and resetting the SBK bit in the SCICR2 register. In some cases, the break character may have a longer duration than expected:

- 20 bits instead of 10 bits if M = 0
- 22 bits instead of 11 bits if M = 1

In the same way, as long as the SBK bit is set, break characters are sent to the TDO pin. This may lead to generating one break more than expected.

Occurrence

The occurrence of the problem is random and proportional to the baud rate. With a transmit frequency of 19200 baud ($f_{\text{CPU}} = 8 \text{ MHz}$ and $\text{SCIBRR} = 0xC9$), the wrong break duration occurrence is around 1%.

Workaround

If this wrong duration is not compliant with the communication protocol in the application, software can request that an Idle line be generated before the break character. In this case, the break duration is always correct assuming the application is not doing anything between the idle and the break. This can be ensured by temporarily disabling interrupts.

The exact sequence is:

- Disable interrupts
- Reset and Set TE (IDLE request)
- Set and Reset SBK (Break Request)
- Re-enable interrupts

22.1.8 16-bit timer PWM mode

In PWM mode, the first PWM pulse is missed after writing the value FFFCh in the OC1R register (OC1HR, OC1LR). It leads to either full or no PWM during a period, depending on the OVL1 and OVL2 settings.

22.1.9 TIMD set simultaneously with OC interrupt

If the 16-bit timer is disabled at the same time the output compare event occurs, the output compare flag then gets locked and cannot be cleared before the timer is enabled again.

Impact on the application

If the output compare interrupt is enabled, then the output compare flag cannot be cleared in the timer interrupt routine. Consequently, the interrupt service routine is called repeatedly.

Workaround

Disable the timer interrupt before disabling the timer. Again while enabling, first enable the timer, then the timer interrupts.

- Perform the following to disable the timer:
 - `TACR1 or TBCR1 = 0x00h; // Disable the compare interrupt`
 - `TACSR | or TBCSR | = 0x40; // Disable the timer`
- Perform the following to enable the timer again:
 - `TACSR & or TBCSR & = ~0x40; // Enable the timer`
 - `TACR1 or TBCR1 = 0x40; // Enable the compare interrupt`

22.1.10 I²C multimaster

In multimaster configurations, if the ST7 I2C receives a START condition from another I2C master after the START bit is set in the I2CCR register and before the START condition is generated by the ST7 I2C, it may ignore the START condition from the other I2C master. In this case, the ST7 master will receive a NACK from the other device. On reception of the NACK, ST7 can send a restart and Slave address to re-initiate communication.

22.1.11 Readout protection with LVD

The LVD is not supported if readout protection is enabled

22.2 All Flash devices

22.2.1 Internal RC oscillator with LVD

The internal RC can only be used if LVD is enabled.

22.3 Limitations specific to ROM devices

22.3.1 LVD operation

Depending on the operating conditions, especially the V_{DD} ramp up speed and ambient temperature, in some cases the LVD may not start. When this occurs, the MCU may operate outside the guaranteed functional area (see [Figure 73](#)) without being forced into reset state.

In this case, proper use of the watchdog may make it possible to recover through a watchdog reset and allow normal operations to resume.

Consequently, the LVD function is not guaranteed in the current silicon revision. For complete security, an external reset circuit must be added.

22.3.2 LVD startup behavior

When the LVD is enabled, the MCU reaches its authorized operating voltage from a reset state. However, in some devices, the reset state is released when V_{DD} is approximately between 0.8V and 1.5V. As a consequence, the I/Os may toggle when V_{DD} is within this window.

This may be an issue especially for applications where the MCU drives power components.

Figure 108. LVD startup behavior

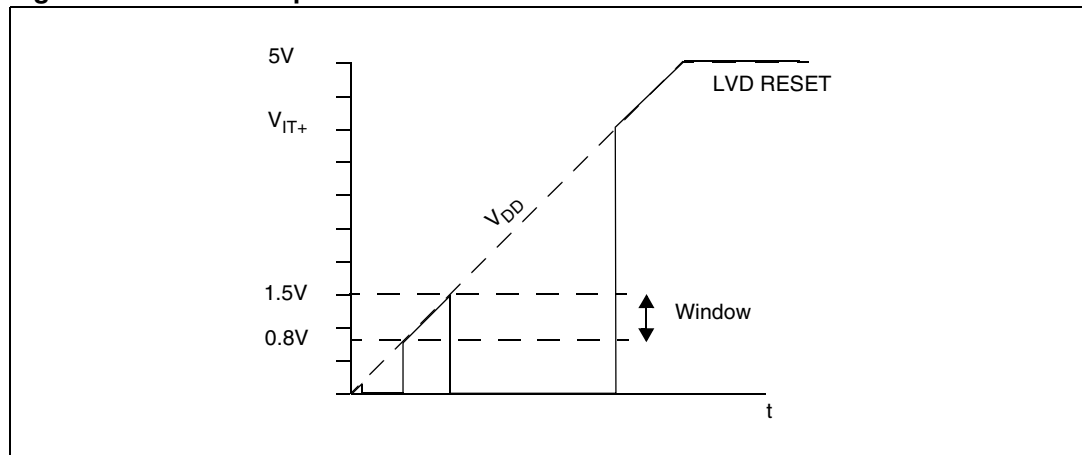

22.3.3 AVD not supported

On some devices with a specific V_{DD} ramp up speed the AVD may not start. As a result it cannot generate interrupts when V_{DD} rises and falls.

22.3.4 Internal RC oscillator operation

Internal RC oscillator operation is not supported in ROM devices.

22.3.5 External clock source with PLL

External clock source is not supported with the PLL enabled.

22.3.6 Pull-up not present on PE2

Unlike ST72F321 Flash devices, ST72321 ROM devices have no weak pull-up on port PE2. In LQFP44 ROM devices, the PE2 pad is not connected to an internal pull-up like other unbonded pads. It is recommended to configure it as output push-pull to avoid added current consumption.

22.3.7 Readout protection with LVD

The LVD is not supported if readout protection is enabled.

23 Revision history

Table 146. Document revision history

Date	Revision	Changes
05-Aug-2010	1	Initial release

Please Read Carefully:

Information in this document is provided solely in connection with ST products. STMicroelectronics NV and its subsidiaries ("ST") reserve the right to make changes, corrections, modifications or improvements, to this document, and the products and services described herein at any time, without notice.

All ST products are sold pursuant to ST's terms and conditions of sale.

Purchasers are solely responsible for the choice, selection and use of the ST products and services described herein, and ST assumes no liability whatsoever relating to the choice, selection or use of the ST products and services described herein.

No license, express or implied, by estoppel or otherwise, to any intellectual property rights is granted under this document. If any part of this document refers to any third party products or services it shall not be deemed a license grant by ST for the use of such third party products or services, or any intellectual property contained therein or considered as a warranty covering the use in any manner whatsoever of such third party products or services or any intellectual property contained therein.

UNLESS OTHERWISE SET FORTH IN ST'S TERMS AND CONDITIONS OF SALE ST DISCLAIMS ANY EXPRESS OR IMPLIED WARRANTY WITH RESPECT TO THE USE AND/OR SALE OF ST PRODUCTS INCLUDING WITHOUT LIMITATION IMPLIED WARRANTIES OF MERCHANTABILITY, FITNESS FOR A PARTICULAR PURPOSE (AND THEIR EQUIVALENTS UNDER THE LAWS OF ANY JURISDICTION), OR INFRINGEMENT OF ANY PATENT, COPYRIGHT OR OTHER INTELLECTUAL PROPERTY RIGHT.

UNLESS EXPRESSLY APPROVED IN WRITING BY AN AUTHORIZED ST REPRESENTATIVE, ST PRODUCTS ARE NOT RECOMMENDED, AUTHORIZED OR WARRANTED FOR USE IN MILITARY, AIR CRAFT, SPACE, LIFE SAVING, OR LIFE SUSTAINING APPLICATIONS, NOR IN PRODUCTS OR SYSTEMS WHERE FAILURE OR MALFUNCTION MAY RESULT IN PERSONAL INJURY, DEATH, OR SEVERE PROPERTY OR ENVIRONMENTAL DAMAGE. ST PRODUCTS WHICH ARE NOT SPECIFIED AS "AUTOMOTIVE GRADE" MAY ONLY BE USED IN AUTOMOTIVE APPLICATIONS AT USER'S OWN RISK.

Resale of ST products with provisions different from the statements and/or technical features set forth in this document shall immediately void any warranty granted by ST for the ST product or service described herein and shall not create or extend in any manner whatsoever, any liability of ST.

ST and the ST logo are trademarks or registered trademarks of ST in various countries.

Information in this document supersedes and replaces all information previously supplied.

The ST logo is a registered trademark of STMicroelectronics. All other names are the property of their respective owners.

© 2010 STMicroelectronics - All rights reserved

STMicroelectronics group of companies

Australia - Belgium - Brazil - Canada - China - Czech Republic - Finland - France - Germany - Hong Kong - India - Israel - Italy - Japan - Malaysia - Malta - Morocco - Philippines - Singapore - Spain - Sweden - Switzerland - United Kingdom - United States of America

www.st.com



Looking for pricing, stock, or lifecycle information?

Click below to explore more details on WIN SOURCE:

- ⊖ [View ST72F321AR9TAE on WIN SOURCE](#)
- ⊖ [STMicroelectronics Information](#)

Optimize Your Supply Chain with WIN SOURCE Solutions

- ✓ Global Sourcing Solution
- ✓ Obsolete Management
- ✓ Cost Control Management
- ✓ Shortage Management
- ✓ Alternative Solution
- ✓ Excess Inventory Management