



# EFC4621R

## Power MOSFET 24V, 9A, 18mΩ N-Channel Dual EFCP

ON Semiconductor®

<http://onsemi.com>

### Features

- 2.5V drive
- Common-drain type
- 2KV ESD HBM
- Protection diode in
- Halogen free compliance

### Applications

- Lithium-ion battery charging and discharging switch

### Specifications

**Absolute Maximum Ratings** at  $T_a = 25^\circ\text{C}$

Parameter	Symbol	Conditions	Ratings	Unit
Source to Source Voltage	$V_{SSS}$		24	V
Gate to Source Voltage	$V_{GSS}$		$\pm 12$	V
Source Current (DC)	$I_S$		9	A
Source Current (Pulse)	$I_{SP}$	$PW \leq 10\mu\text{s}$ , duty cycle $\leq 1\%$	60	A
Total Dissipation	$P_T$	When mounted on ceramic substrate (5000mm <sup>2</sup> ×0.8mm)	1.6	W
Channel Temperature	$T_{ch}$		150	°C
Storage Temperature	$T_{stg}$		-55 to +150	°C

Stresses exceeding Maximum Ratings may damage the device. Maximum Ratings are stress ratings only. Functional operation above the Recommended Operating Conditions is not implied. Extended exposure to stresses above the Recommended Operating Conditions may affect device reliability.

### Package Dimensions

unit : mm (typ)

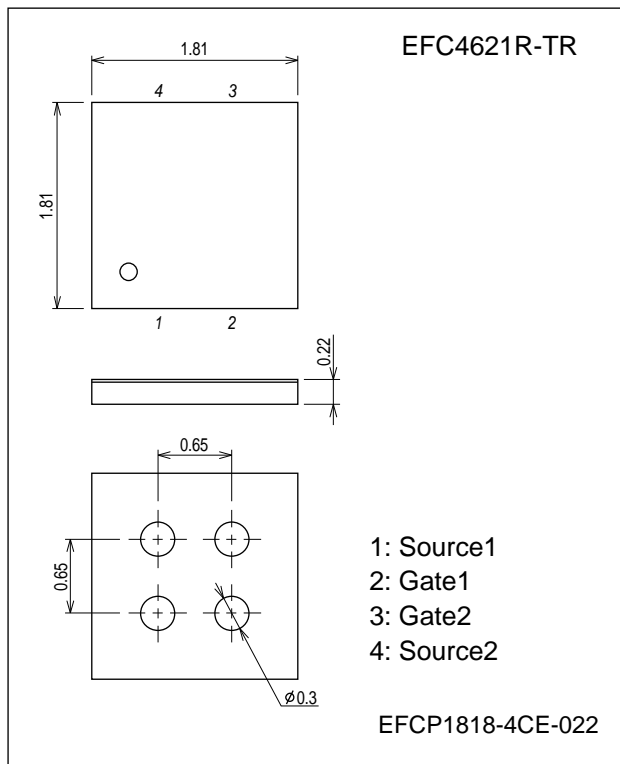

### Ordering & Package Information

Device	Package	Shipping	note
EFC4621R-TR	EFCP	5000 pcs. / reel	Pb-Free and Halogen-Free

### Packing Type: TR

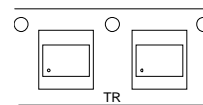

### Marking

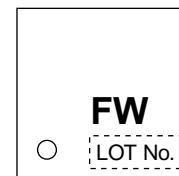

### Electrical Connection

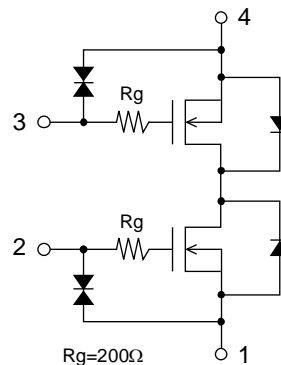

# EFC4621R

## Electrical Characteristics at Ta = 25°C

Parameter	Symbol	Conditions	Ratings			Unit
			min	typ	max	
Source to Source Breakdown Voltage	V(BR) <sub>SSS</sub>	I <sub>S</sub> =1mA, V <sub>GS</sub> =0V Test Circuit 1	24			V
Zero-Gate Voltage Source Current	I <sub>SSS</sub>	V <sub>SS</sub> =20V, V <sub>GS</sub> =0V Test Circuit 1			1	μA
Gate to Source Leakage Current	I <sub>GSS</sub>	V <sub>GS</sub> =±8V, V <sub>SS</sub> =0V Test Circuit 2			±1	μA
Cutoff Voltage	V <sub>GS(off)</sub>	V <sub>SS</sub> =10V, I <sub>S</sub> =1mA Test Circuit 3	0.5		1.3	V
Forward Transfer Admittance	y <sub>fs</sub>	V <sub>SS</sub> =10V, I <sub>S</sub> =3A Test Circuit 4		7.3		S
Static Source to Source On-State Resistance	R <sub>SS(on)1</sub>	I <sub>S</sub> =3A, V <sub>GS</sub> =4.5V Test Circuit 5	10.8	15.5	18	mΩ
	R <sub>SS(on)2</sub>	I <sub>S</sub> =3A, V <sub>GS</sub> =4.0V Test Circuit 5	11.1	16	19	mΩ
	R <sub>SS(on)3</sub>	I <sub>S</sub> =3A, V <sub>GS</sub> =3.7V Test Circuit 5	11.5	16.5	20	mΩ
	R <sub>SS(on)4</sub>	I <sub>S</sub> =3A, V <sub>GS</sub> =3.1V Test Circuit 5	12.5	18	23.5	mΩ
	R <sub>SS(on)5</sub>	I <sub>S</sub> =3A, V <sub>GS</sub> =2.5V Test Circuit 5	14.9	23	30	mΩ
Turn-ON Delay Time	t <sub>d(on)</sub>	V <sub>SS</sub> =10V, V <sub>GS</sub> =4.5V, I <sub>S</sub> =3A Test Circuit 7		340		ns
Rise Time	t <sub>r</sub>			600		ns
Turn-OFF Delay Time	t <sub>d(off)</sub>			26000		ns
Fall Time	t <sub>f</sub>			28000		ns
Total Gate Charge	Q <sub>g</sub>		V <sub>SS</sub> =10V, V <sub>GS</sub> =4.5V, I <sub>S</sub> =9A Test Circuit 8		29	
Forward Source to Source Voltage	V <sub>F(S-S)</sub>	I <sub>S</sub> =3A, V <sub>GS</sub> =0V Test Circuit 6		0.77	1.2	V

Test circuits are example of measuring FET1 side

Test Circuit 1  
I<sub>SSS</sub>

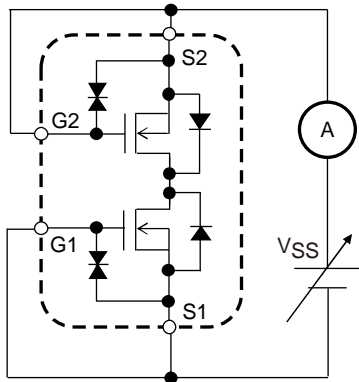

Test Circuit 2  
I<sub>GSS</sub>

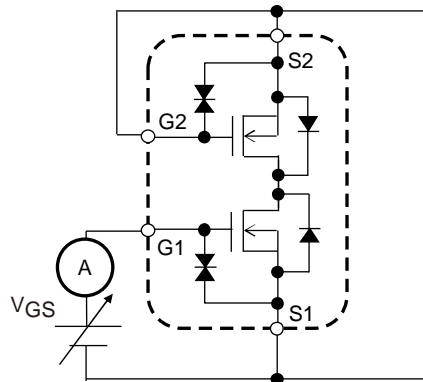

When FET1 is measured, Gate and Source of FET2 are short-circuited.

Test Circuit 3  
V<sub>GS(off)</sub>

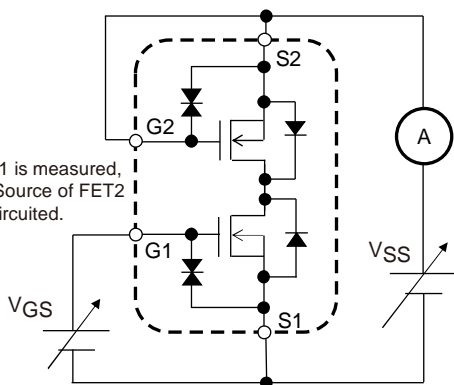

When FET1 is measured, Gate and Source of FET2 are short-circuited.

Test Circuit 4  
|y<sub>fs</sub>|

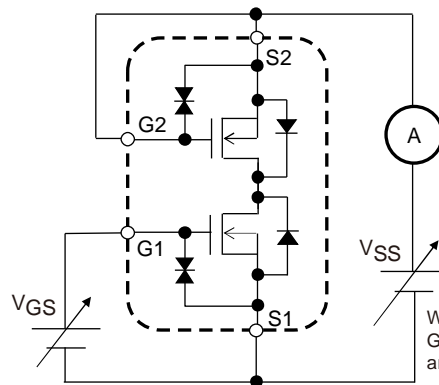

When FET1 is measured, Gate and Source of FET2 are short-circuited.

Test Circuit 5  
R<sub>SS(on)</sub>

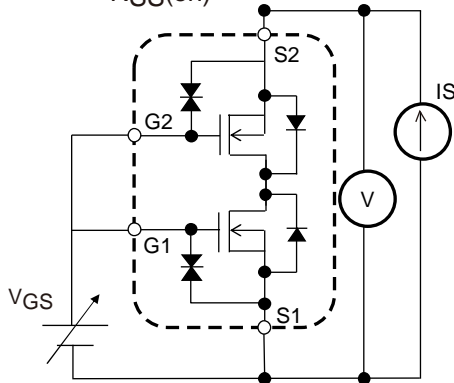

Test Circuit 6  
V<sub>F(S-S)</sub>

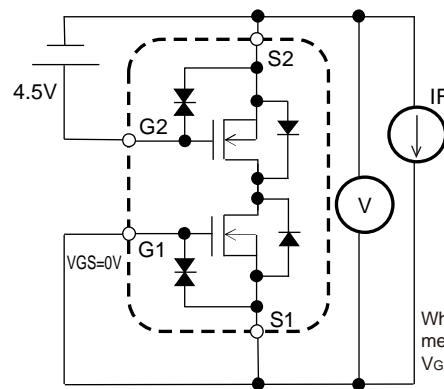

When FET1 is measured, +4.5V is added to V<sub>GS</sub> of FET2.

Test Circuit 7  
t<sub>d(on)</sub>, t<sub>r</sub>, t<sub>d(off)</sub>, t<sub>f</sub>

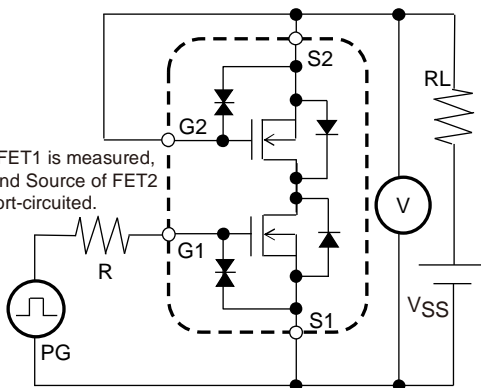

When FET1 is measured, Gate and Source of FET2 are short-circuited.

Test Circuit 8  
Q<sub>g</sub>

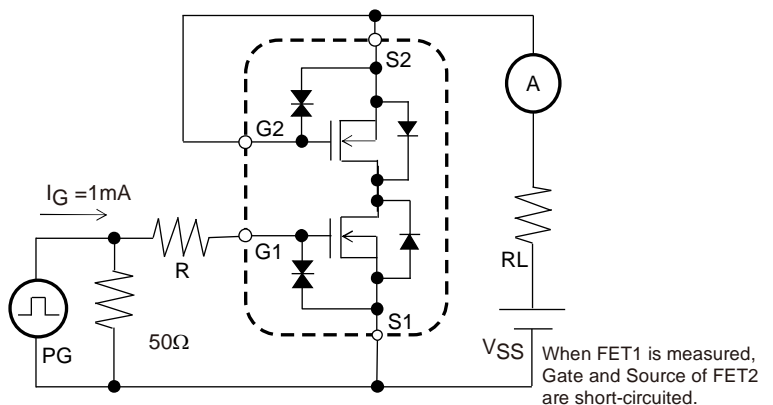

When FET1 is measured, Gate and Source of FET2 are short-circuited.

# EFC4621R

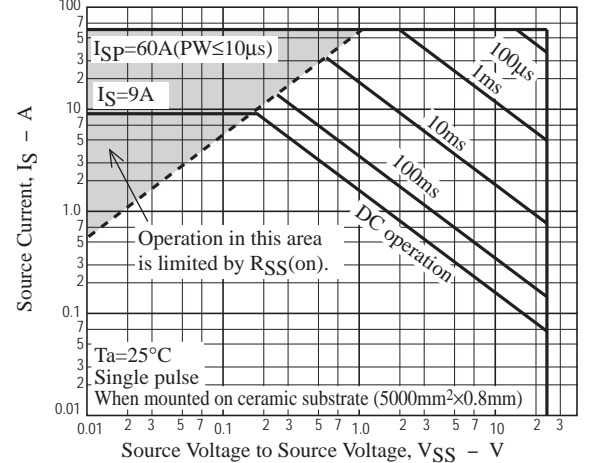
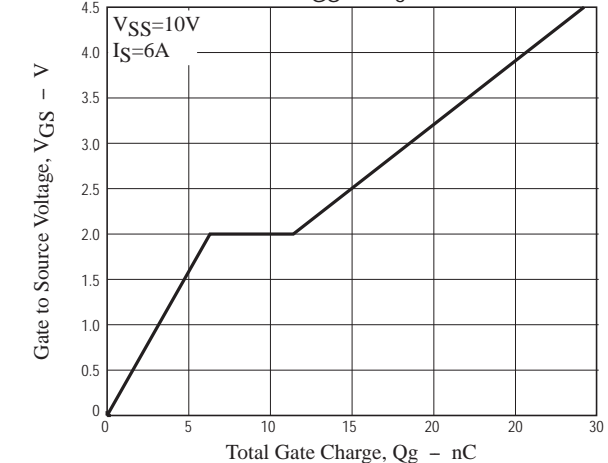
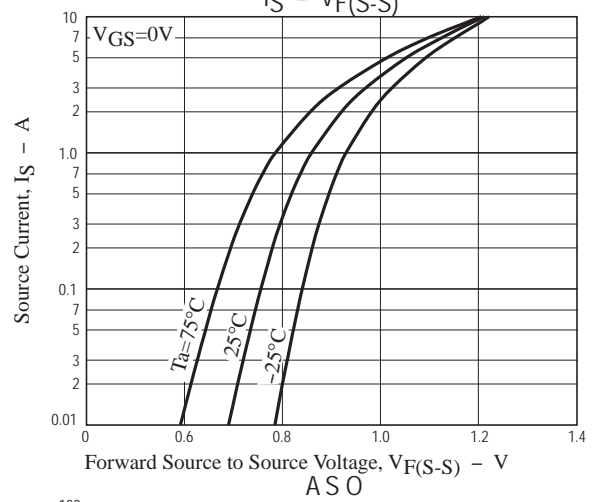
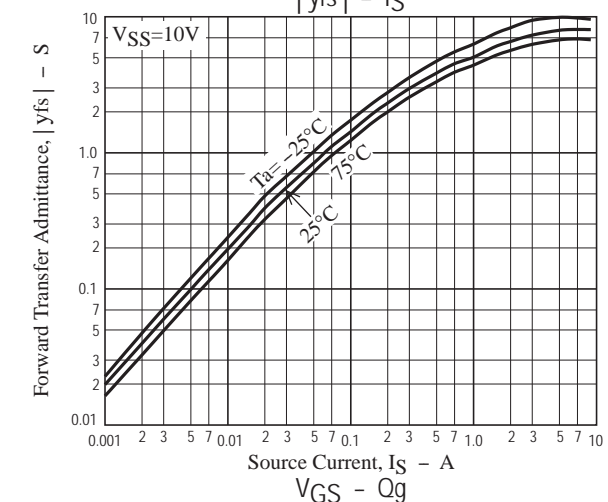
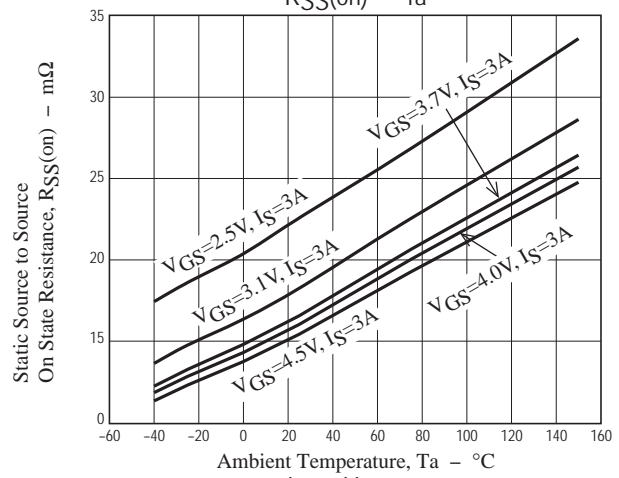
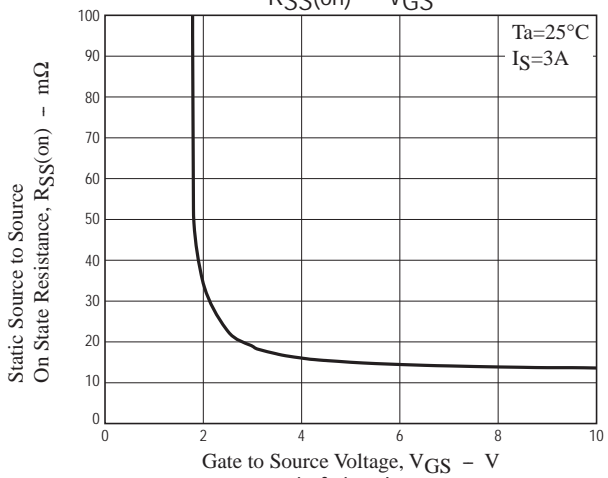
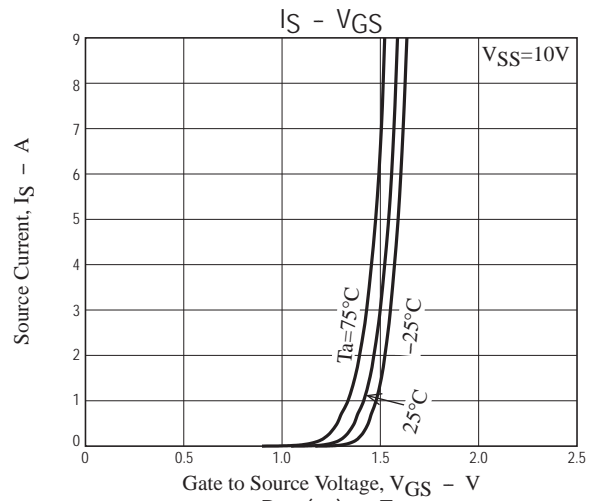
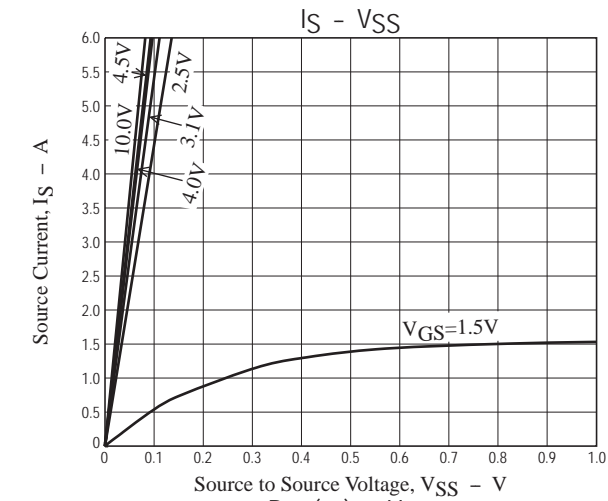

EFC4621R

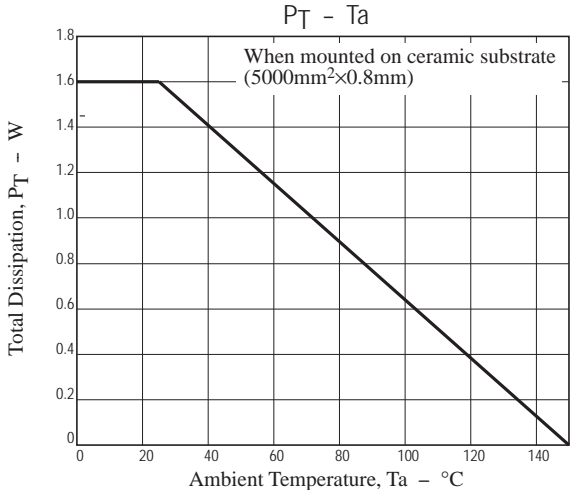

Taping Specification

EFC4621R-TR

1. Taping Configuration

1-1. Carrier Tape Size (unit:mm)

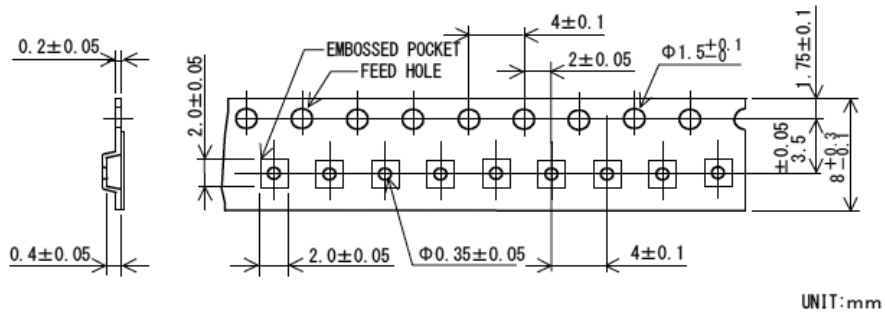

1-2. Device Placement Direction

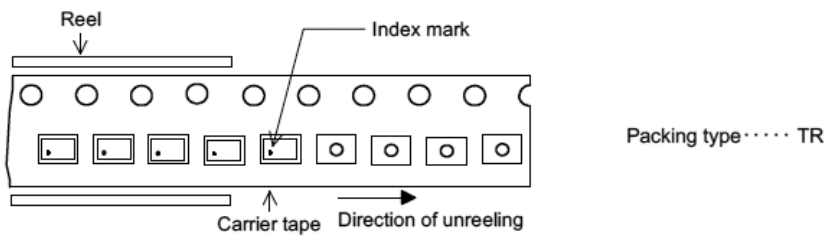

1-3. Leader portion and Trailer portion (unit:mm)

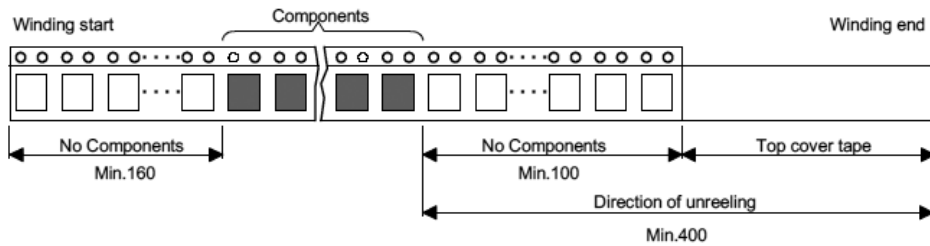

# EFC4621R

## Packing Format

Carrier Tape code	Package code	Maximum Number of devices contained. (pcs.)			Packing Format	
		Reel	Inner box		Inner box BOX(C-1)	
2020X04	EFCP1818-4CE-022	5,000	25,000		5reels contained. Dimensions:mm 183×72×185	

## MPN Label

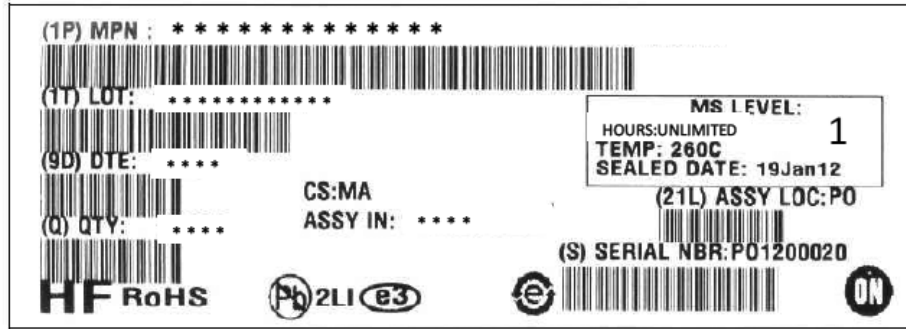

## Packing Method

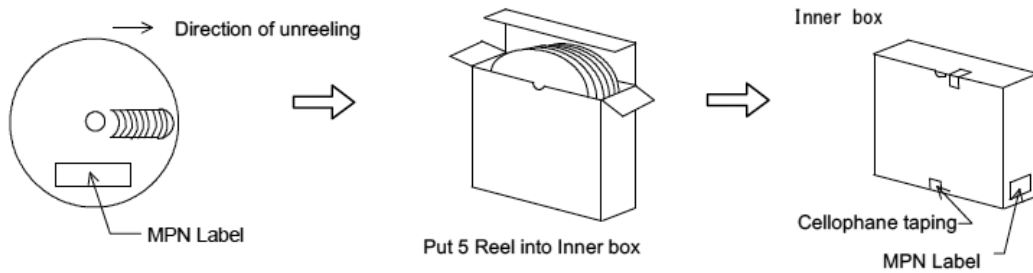

# EFC4621R

## Outline Drawing

EFC4621R-TR

## Land Pattern Example

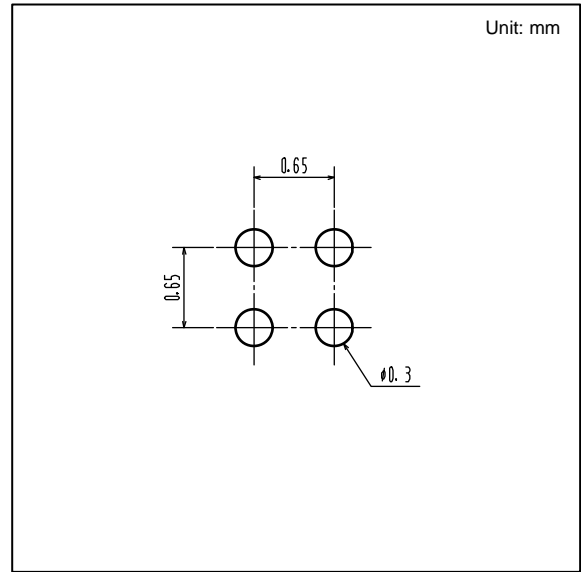
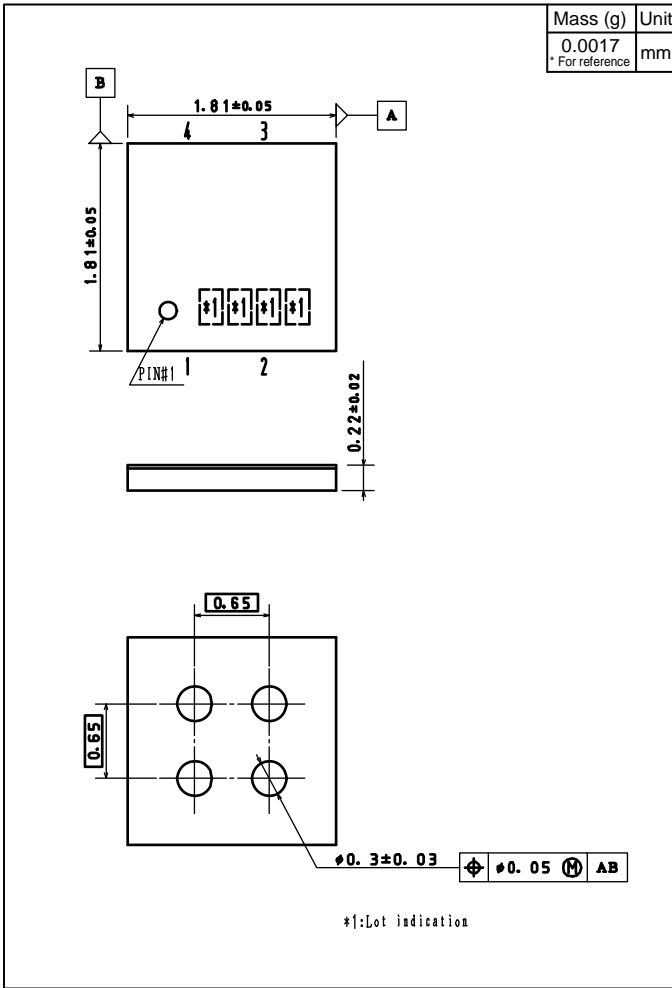

Note on usage : Since the EFC4621R is a MOSFET product, please avoid using this device in the vicinity of highly charged objects.

ON Semiconductor and the ON logo are registered trademarks of Semiconductor Components Industries, LLC (SCILLC). SCILLC owns the rights to a number of patents, trademarks, copyrights, trade secrets, and other intellectual property. A listing of SCILLC's product/patent coverage may be accessed at [www.onsemi.com/site/pdf/Patent-Marking.pdf](http://www.onsemi.com/site/pdf/Patent-Marking.pdf). SCILLC reserves the right to make changes without further notice to any products herein. SCILLC makes no warranty, representation or guarantee regarding the suitability of its products for any particular purpose, nor does SCILLC assume any liability arising out of the application or use of any product or circuit, and specifically disclaims any and all liability, including without limitation special, consequential or incidental damages. "Typical" parameters which may be provided in SCILLC data sheets and/or specifications can and do vary in different applications and actual performance may vary over time. All operating parameters, including "Typicals" must be validated for each customer application by customer's technical experts. SCILLC does not convey any license under its patent rights nor the rights of others. SCILLC products are not designed, intended, or authorized for use as components in systems intended for surgical implant into the body, or other applications intended to support or sustain life, or for any other application in which the failure of the SCILLC product could create a situation where personal injury or death may occur. Should Buyer purchase or use SCILLC products for any such unintended or unauthorized application, Buyer shall indemnify and hold SCILLC and its officers, employees, subsidiaries, affiliates, and distributors harmless against all claims, costs, damages, and expenses, and reasonable attorney fees arising out of, directly or indirectly, any claim of personal injury or death associated with such unintended or unauthorized use, even if such claim alleges that SCILLC was negligent regarding the design or manufacture of the part. SCILLC is an Equal Opportunity/Affirmative Action Employer. This literature is subject to all applicable copyright laws and is not for resale in any manner.

## Looking for pricing, stock, or lifecycle information?

Click below to explore more details on WIN SOURCE:

- ⊖ [View EFC4621R-TR on WIN SOURCE](#)
- ⊖ [ON Semiconductor Information](#)

## Optimize Your Supply Chain with WIN SOURCE Solutions

- ✓ Global Sourcing Solution
- ✓ Obsolete Management
- ✓ Cost Control Management
- ✓ Shortage Management
- ✓ Alternative Solution
- ✓ Excess Inventory Management