



**THE DATASHEET OF  
AT27C010-45JU**



## Features

- Fast read access time – 45ns
- Low-power CMOS operation
  - 100µA max standby
  - 25mA max active at 5MHz
- JEDEC standard packages
  - 32-lead PDIP
  - 32-lead PLCC
- 5V ± 10% supply
- High-reliability CMOS technology
  - 2000V ESD protection
  - 200mA latchup immunity
- Rapid programming algorithm – 100 µs/byte (typical)
- CMOS- and TTL-compatible inputs and outputs
- Integrated product identification code
- Industrial temperature range
- Green (Pb/halide-free) packaging option

### 1. Description

The Atmel® AT27C010 is a low-power, high-performance 1,048,576-bit, one-time programmable, read-only memory (OTP EPROM) organized as 128K by 8 bits. The device requires only one 5V power supply in normal read mode operation. Any byte can be accessed in less than 45ns, eliminating the need for speed reducing WAIT states on high-performance microprocessor systems.

In read mode, the AT27C010 typically consumes only 8mA. Standby mode supply current is typically less than 10µA.

The AT27C010 is available in a choice of industry standard, JEDEC approved, one-time programmable (OTP) PDIP and PLCC packages. All devices feature two-line control ( $\overline{CE}$ ,  $\overline{OE}$ ) to give designers the flexibility to prevent bus contention.

With 128K byte storage capability, the AT27C010 allows firmware to be stored reliably and to be accessed by the system without the delays of mass storage media.

The AT27C010 has additional features to ensure high quality and efficient production use. The rapid programming algorithm reduces the time required to program the part and guarantees reliable programming. Programming time is typically only 100 µs/byte. The integrated product identification code electronically identifies the device and manufacturer. This feature is used by industry standard programming equipment to select the proper programming algorithms and voltages.



1Mb ( 128K x 8 )  
One-time  
Programmable,  
Read-only Memory

Atmel AT27C010



## 2. Pin configurations

Pin name	Function
A0 - A16	Addresses
O0 - O7	Outputs
$\overline{CE}$	Chip enable
$\overline{OE}$	Output enable
PGM	Program strobe
NC	No connect

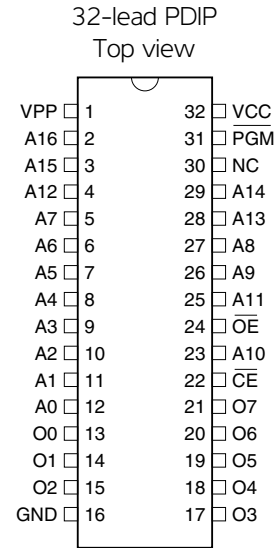
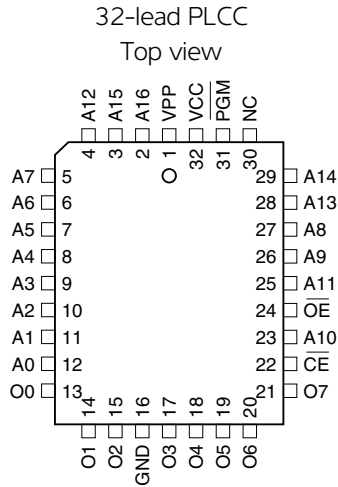

## 3. System considerations

Switching between active and standby conditions via the chip enable pin may produce transient voltage excursions. Unless accommodated by the system design, these transients may exceed datasheet limits, resulting in device nonconformance. At a minimum, a 0.1 $\mu$ F, high-frequency, low inherent inductance, ceramic capacitor should be utilized for each device. This capacitor should be connected between the  $V_{CC}$  and ground terminals of the device, as close to the device as possible. Additionally, to stabilize the supply voltage level on printed circuit boards with large EPROM arrays, a 4.7 $\mu$ F bulk electrolytic capacitor should be utilized, again connected between the  $V_{CC}$  and ground terminals. This capacitor should be positioned as close as possible to the point where the power supply is connected to the array.

Figure 3-1. Block diagram

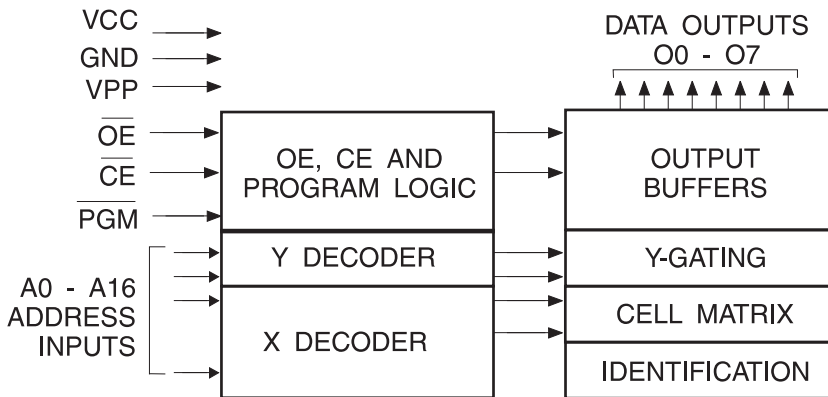

4. Absolute maximum ratings\*

Temperature under bias . . . . .	-55°C to +125°C
Storage temperature . . . . .	-65°C to +150°C
Voltage on any pin with respect to ground . . . . .	-2.0V to +7.0V <sup>(1)</sup>
Voltage on A9 with respect to ground . . . . .	-2.0V to +14.0V <sup>(1)</sup>
V <sub>pp</sub> supply voltage with respect to ground . . . . .	-2.0V to +14.0V <sup>(1)</sup>

**\*NOTICE:** Stresses beyond those listed under “Absolute maximum ratings” may cause permanent damage to the device. This is a stress rating only, and functional operation of the device at these or any other conditions beyond those indicated in the operational sections of this specification is not implied. Exposure to absolute maximum rating conditions for extended periods may affect device reliability.

Note: 1. Minimum voltage is -0.6V DC, which may undershoot to -2.0V for pulses of less than 20ns. Maximum output pin voltage is V<sub>CC</sub> + 0.75V DC, which may overshoot to +7.0V for pulses of less than 20ns.

5. DC and AC characteristics

Table 5-1. Operating modes

Mode/Pin	$\overline{CE}$	$\overline{OE}$	$\overline{PGM}$	Ai	V <sub>pp</sub>	Outputs
Read	V <sub>IL</sub>	V <sub>IL</sub>	X <sup>(1)</sup>	Ai	X	D <sub>OUT</sub>
Output disable	X	V <sub>IH</sub>	X	X	X	High Z
Standby	V <sub>IH</sub>	X	X	X	X	High Z
Rapid program <sup>(2)</sup>	V <sub>IL</sub>	V <sub>IH</sub>	V <sub>IL</sub>	Ai	V <sub>pp</sub>	D <sub>IN</sub>
PGM verify	V <sub>IL</sub>	V <sub>IL</sub>	V <sub>IH</sub>	Ai	V <sub>pp</sub>	D <sub>OUT</sub>
PGM inhibit	V <sub>IH</sub>	X	X	X	V <sub>pp</sub>	High Z
Product identification <sup>(4)</sup>	V <sub>IL</sub>	V <sub>IL</sub>	X	A9 = V <sub>H</sub> <sup>(3)</sup> A0 = V <sub>IH</sub> or V <sub>IL</sub> A1 - A16 = V <sub>IL</sub>	X	Identification code

Note: 1. X can be V<sub>IL</sub> or V<sub>IH</sub>.  
 2. Refer to programming characteristics.  
 3. V<sub>H</sub> = 12.0 ± 0.5V.  
 4. Two identifier bytes may be selected. All Ai inputs are held low (V<sub>IL</sub>), except A9, which is set to V<sub>IH</sub>, and A0, which is toggled low (V<sub>IL</sub>) to select the manufacturer’s identification byte and high (V<sub>IH</sub>) to select the device code byte.

Table 5-2. DC and AC operating conditions for read operation

		Atmel AT27C010	
		-45	-70
Operating temp. (case)	Ind.	-40°C - 85°C	-40°C - 85°C
V <sub>CC</sub> power supply		5V ± 10%	5V ± 10%



Table 5-3. DC and operating characteristics for read operation

Symbol	Parameter	Condition	Min	Max	Units
$I_{LI}$	Input load current	$V_{IN} = 0V$ to $V_{CC}$	Ind.	$\pm 1$	$\mu A$
$I_{LO}$	Output leakage current	$V_{OUT} = 0V$ to $V_{CC}$	Ind.	$\pm 5$	$\mu A$
$I_{PP1}^{(2)}$	$V_{PP}^{(1)}$ read/standby current	$V_{PP} = V_{CC}$		10	$\mu A$
$I_{SB}$	$V_{CC}^{(1)}$ standby current	$I_{SB1}$ (CMOS), $\overline{CE} = V_{CC} \pm 0.3V$		100	$\mu A$
		$I_{SB2}$ (TTL), $\overline{CE} = 2.0$ to $V_{CC} + 0.5V$		1	mA
$I_{CC}$	$V_{CC}$ active current	$f = 5MHz$ , $I_{OUT} = 0mA$ , $\overline{CE} = V_{IL}$		25	mA
$V_{IL}$	Input low voltage		-0.6	0.8	V
$V_{IH}$	Input high voltage		2.0	$V_{CC} + 0.5$	V
$V_{OL}$	Output low voltage	$I_{OL} = 2.1mA$		0.4	V
$V_{OH}$	Output high voltage	$I_{OH} = -400\mu A$	2.4		V

- Notes:
- $V_{CC}$  must be applied simultaneously or before  $V_{pp}$ , and removed simultaneously or after  $V_{pp}$ .
  - $V_{pp}$  may be connected directly to  $V_{CC}$ , except during programming. The supply current would then be the sum of  $I_{CC}$  and  $I_{pp}$ .

Table 5-4. AC characteristics for read operation

Symbol	Parameter	Condition	Atmel AT27C010				Units
			-45		-70		
			Min	Max	Min	Max	
$t_{ACC}^{(3)}$	Address to output delay	$\overline{CE} = \overline{OE} = V_{IL}$		45		70	ns
$t_{CE}^{(2)}$	$\overline{CE}$ to output delay	$\overline{OE} = V_{IL}$		45		70	ns
$t_{OE}^{(2)(3)}$	$\overline{OE}$ to output delay	$\overline{CE} = V_{IL}$		20		30	ns
$t_{DF}^{(4)(5)}$	$\overline{OE}$ or $\overline{CE}$ high to output float, whichever occurred first			20		25	ns
$t_{OH}$	Output hold from address, $\overline{CE}$ or $\overline{OE}$ , whichever occurred first		7		7		ns

Figure 5-1. AC waveforms for read operation<sup>(1)</sup>

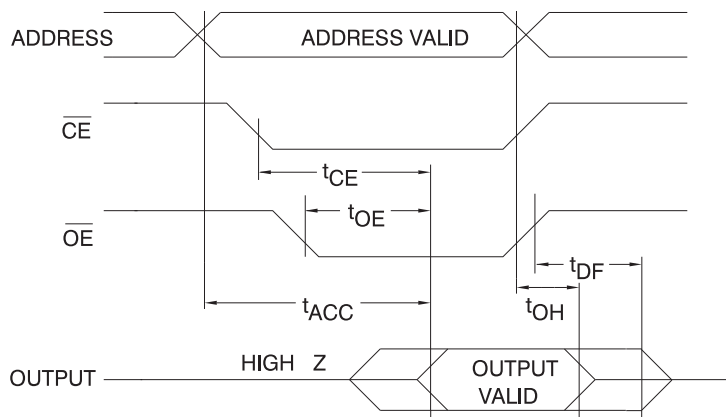

- Notes:
- Timing measurement reference level is 1.5V for -45 devices. Input AC drive levels are  $V_{IL} = 0.0V$  and  $V_{IH} = 3.0V$ . Timing measurement reference levels for all other speed grades are  $V_{OL} = 0.8V$  and  $V_{OH} = 2.0V$ . Input AC drive levels are  $V_{IL} = 0.45V$  and  $V_{IH} = 2.4V$ .
  - $\overline{OE}$  may be delayed up to  $t_{CE} - t_{OE}$  after the falling edge of  $\overline{CE}$  without impact on  $t_{CE}$ .
  - $\overline{OE}$  may be delayed up to  $t_{ACC} - t_{OE}$  after the address is valid without impact on  $t_{ACC}$ .
  - This parameter is only sampled, and is not 100% tested.
  - Output float is defined as the point when data is no longer driven.

Figure 5-2. Input test waveforms and measurement levels

For -45 devices only:

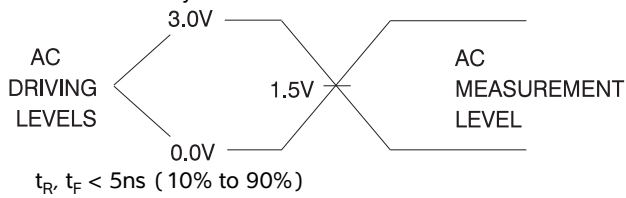

For -70 devices:

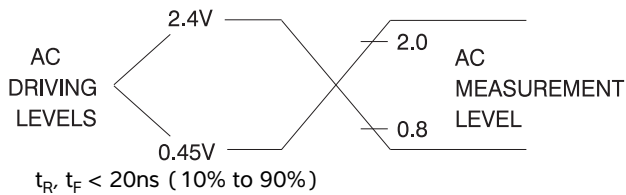
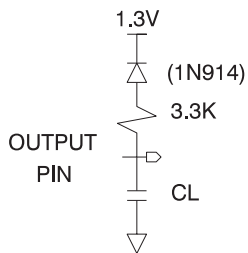

Figure 5-3. Output test load



$C_L = 100\text{pF}$  including jig capacitance, except for the -45 devices, where  $C_L = 30\text{pF}$

Table 5-5. Pin capacitance

$f = 1\text{MHz}$ ,  $T = 25^\circ\text{C}^{(1)}$

Symbol	Typ	Max	Units	Conditions
$C_{IN}$	4	8	pF	$V_{IN} = 0V$
$C_{OUT}$	8	12	pF	$V_{OUT} = 0V$

Note: 1. Typical values for nominal supply voltage. This parameter is only sampled, and is not 100% tested.

Figure 5-4. Programming Waveforms<sup>(1)</sup>

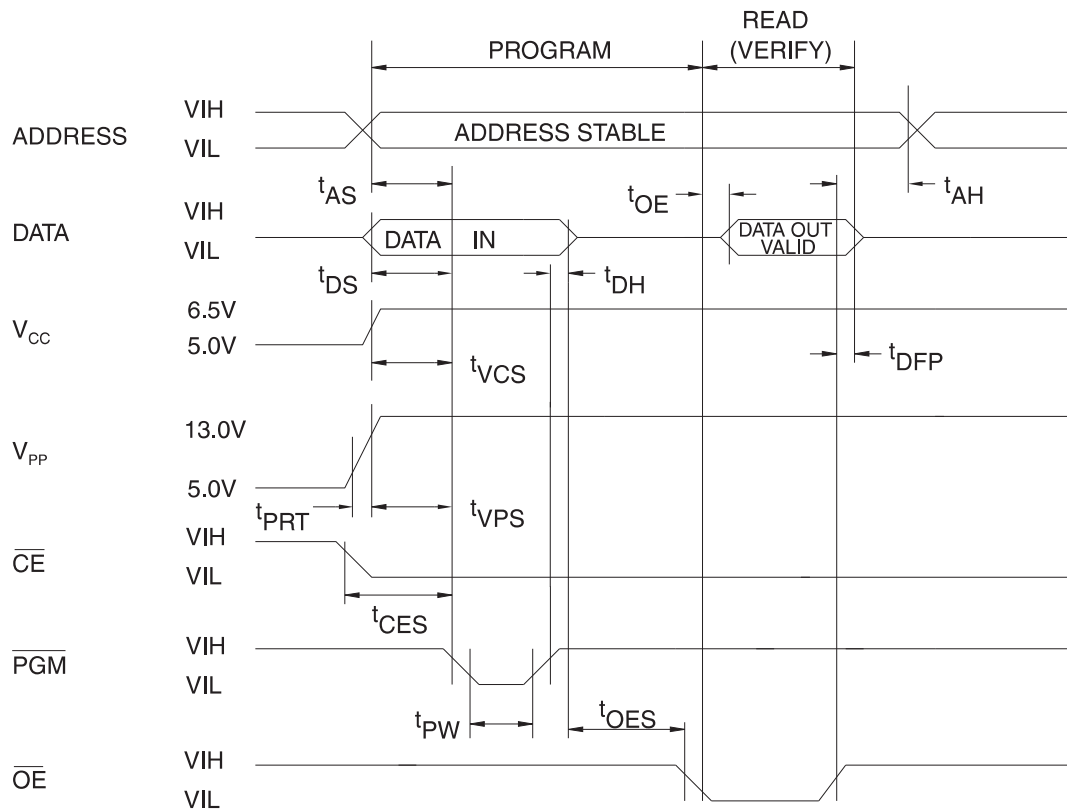

- Notes:
1. The input timing reference is 0.8V for V<sub>L</sub> and 2.0V for V<sub>IH</sub>.
  2.  $t_{OE}$  and  $t_{DFP}$  are characteristics of the device, but must be accommodated by the programmer.
  3. When programming the Atmel AT27C010, a 0.1 $\mu$ F capacitor is required across V<sub>pp</sub> and ground to suppress spurious voltage transients.

Table 5-6. DC programming characteristics

 $T_A = 25 \pm 5^\circ\text{C}$ ,  $V_{CC} = 6.5 \pm 0.25\text{V}$ ,  $V_{PP} = 13.0 \pm 0.25\text{V}$ 

Symbol	Parameter	Test conditions	Limits		Units
			Min	Max	
$I_{LI}$	Input load current	$V_{IN} = V_{IL}, V_{IH}$		$\pm 10$	$\mu\text{A}$
$V_{IL}$	Input low level		-0.6	0.8	V
$V_{IH}$	Input high level		2.0	$V_{CC} + 1$	V
$V_{OL}$	Output low voltage	$I_{OL} = 2.1\text{mA}$		0.4	V
$V_{OH}$	Output high voltage	$I_{OH} = -400\mu\text{A}$	2.4		V
$I_{CC2}$	$V_{CC}$ supply current (program and verify)			40	mA
$I_{PP2}$	$V_{PP}$ supply current	$\overline{CE} = \overline{PGM} = V_{IL}$		20	mA
$V_{ID}$	A9 product identification voltage		11.5	12.5	V

Table 5-7. AC programming characteristics

 $T_A = 25 \pm 5^\circ\text{C}$ ,  $V_{CC} = 6.5 \pm 0.25\text{V}$ ,  $V_{PP} = 13.0 \pm 0.25\text{V}$ 

Symbol	Parameter	Test conditions <sup>(1)</sup>	Limits		Units
			Min	Max	
$t_{AS}$	Address setup time	Input rise and fall times (10% to 90%) 20ns	2		$\mu\text{s}$
$t_{CES}$	$\overline{CE}$ setup time		2		$\mu\text{s}$
$t_{OES}$	$\overline{OE}$ setup time		2		$\mu\text{s}$
$t_{DS}$	Data setup time		2		$\mu\text{s}$
$t_{AH}$	Address hold time	Input pulse levels 0.45V to 2.4V	0		$\mu\text{s}$
$t_{DH}$	Data hold time		2		$\mu\text{s}$
$t_{DFP}$	$\overline{OE}$ high to output float delay <sup>(2)</sup>	Input timing reference level 0.8V to 2.0V	0	130	ns
$t_{VPS}$	$V_{PP}$ setup time		2		$\mu\text{s}$
$t_{VCS}$	$V_{CC}$ setup time	Output timing reference level 0.8V to 2.0V	2		$\mu\text{s}$
$t_{PW}$	$\overline{PGM}$ program pulse width <sup>(3)</sup>		95	105	$\mu\text{s}$
$t_{OE}$	Data valid from $\overline{OE}$			150	ns
$t_{PRT}$	$V_{PP}$ pulse rise time during programming		50		ns

- Notes:
- $V_{CC}$  must be applied simultaneously with or before  $V_{PP}$  and removed simultaneously with or after  $V_{PP}$ .
  - This parameter is only sampled, and is not 100% tested. Output float is defined as the point where data is no longer driven. See timing diagram.
  - Program pulse width tolerance is  $100\mu\text{sec} \pm 5\%$ .

Table 5-8. The Atmel AT27C010 integrated product identification code

Codes	Pins									Hex data
	A0	O7	O6	O5	O4	O3	O2	O1	O0	
Manufacturer	0	0	0	0	1	1	1	1	0	1E
Device type	1	0	0	0	0	0	1	0	1	05

## 6. Rapid programming algorithm

A  $100\mu\text{s}$   $\overline{\text{PGM}}$  pulse width is used to program. The address is set to the first location.  $V_{\text{CC}}$  is raised to 6.5V and  $V_{\text{PP}}$  is raised to 13.0V. Each address is first programmed with one  $100\mu\text{s}$   $\overline{\text{PGM}}$  pulse without verification. Then a verification/reprogramming loop is executed for each address. In the event a byte fails to pass verification, up to 10 successive  $100\mu\text{s}$  pulses are applied with a verification after each pulse. If the byte fails to verify after 10 pulses have been applied, the part is considered failed. After the byte verifies properly, the next address is selected until all have been checked.  $V_{\text{PP}}$  is then lowered to 5.0V and  $V_{\text{CC}}$  to 5.0V. All bytes are read again and compared with the original data to determine if the device passes or fails.

Figure 6-1. Rapid programming algorithm

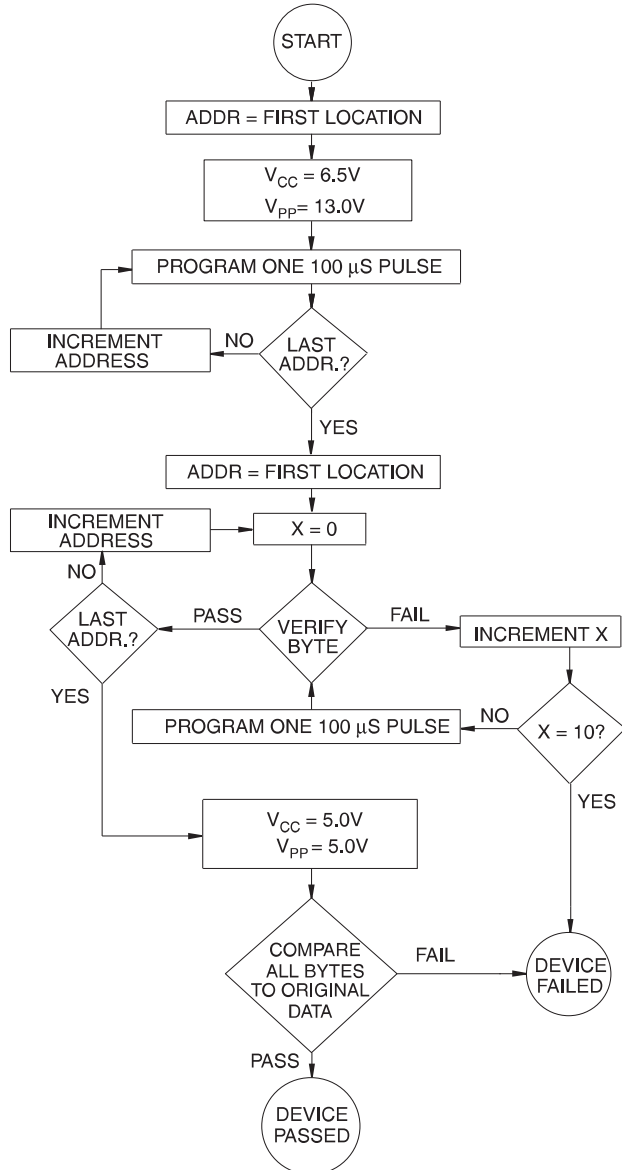

## 7. Ordering information

## Green package option (Pb/halide-free)

t <sub>ACC</sub> (ns)	I <sub>CC</sub> (mA)		Atmel ordering code	Package	Lead finish	Operation range
	Active	Standby				
45	25	0.1	AT27C010-45JU	32J	Matte tin	Industrial (-40°C to 85°C)
70	25	0.1	AT27C010-70JU AT27C010-70PU	32J 32P6	Matte tin Matte tin	Industrial (-40°C to 85°C)

Package type	
<b>32J</b>	32-lead, plastic, J-leaded chip carrier (PLCC)
<b>32P6</b>	32-lead, 0.600" wide, plastic, dual inline package (PDIP)

## 8. Package Information

### 32J – PLCC

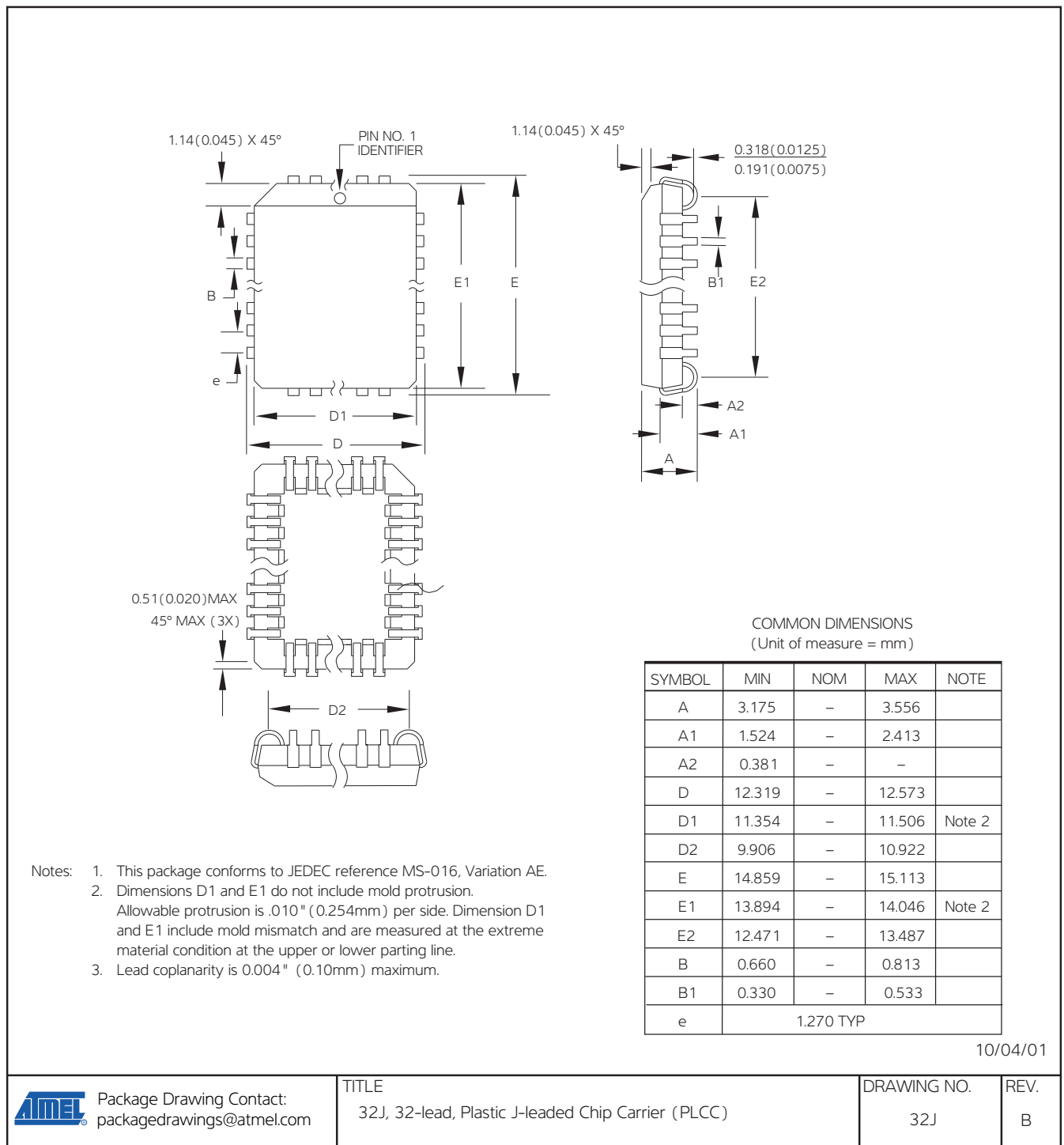

32P6 – PDIP

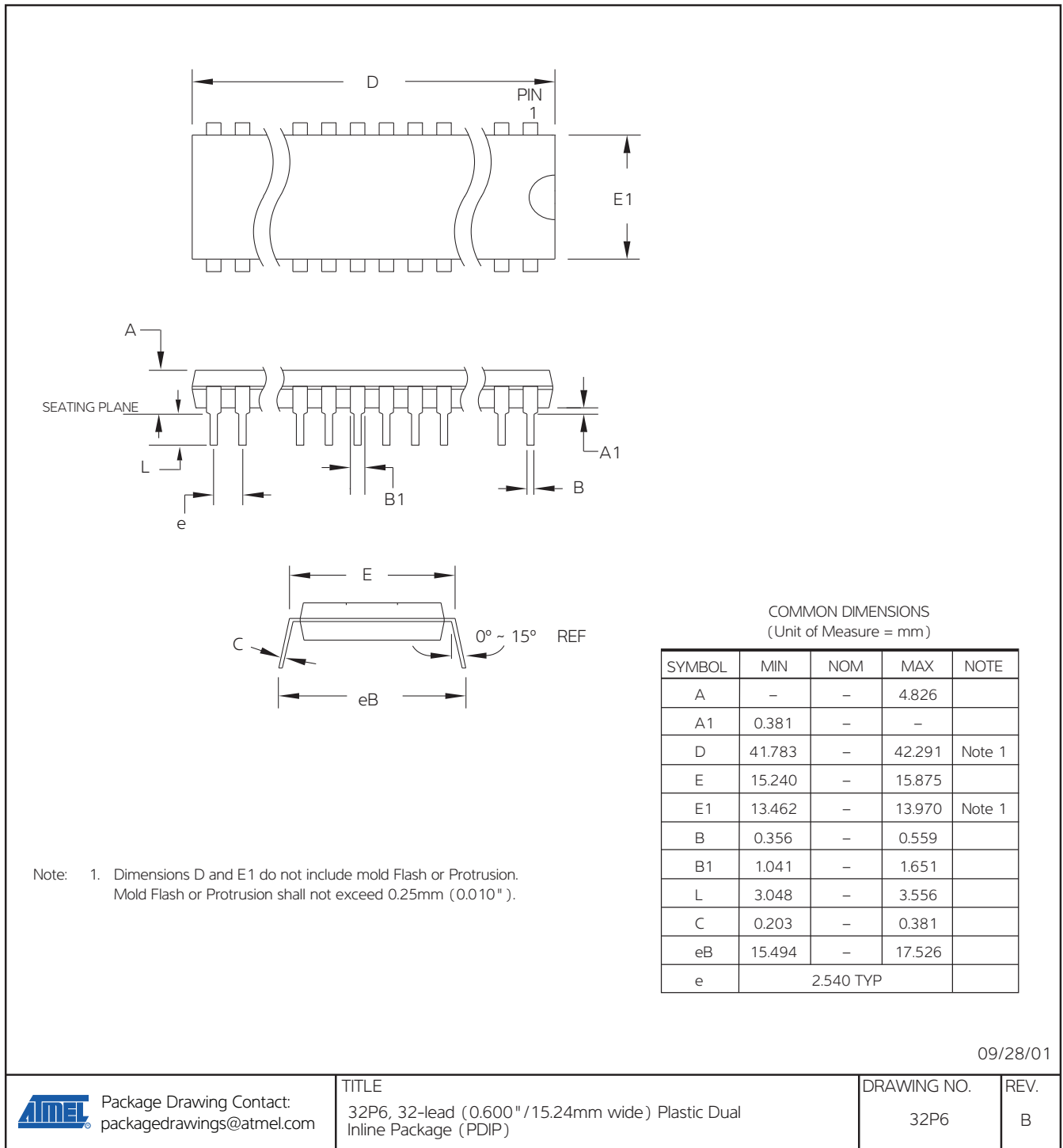

09/28/01



Package Drawing Contact:  
packagedrawings@atmel.com

TITLE

32P6, 32-lead (0.600"/15.24mm wide) Plastic Dual  
Inline Package (PDIP)

DRAWING NO.

32P6

REV.

B





9. Revision history

Doc. Rev.	Date	Comments
0321N	04/2011	Remove TSOP package Add lead finish to ordering information
0321M	12/2007	



**Atmel Corporation**

2325 Orchard Parkway  
San Jose, CA 95131  
USA

**Tel:** (+1) (408) 441-0311

**Fax:** (+1) (408) 487-2600

[www.atmel.com](http://www.atmel.com)

**Atmel Asia Limited**

Unit 01-5 & 16, 19F  
BEA Tower, Millennium City 5  
418 Kwun Tong Road

Kwun Tong, Kowloon

HONG KONG

**Tel:** (+852) 2245-6100

**Fax:** (+852) 2722-1369

**Atmel Munich GmbH**

Business Campus  
Parkring 4  
D-85748 Garching b. Munich  
GERMANY

**Tel:** (+49) 89-31970-0

**Fax:** (+49) 89-3194621

**Atmel Japan**

9F, Tonetsu Shinkawa Bldg.  
1-24-8 Shinkawa  
Chuo-ku, Tokyo 104-0033  
JAPAN

**Tel:** (+81) (3) 3523-3551

**Fax:** (+81) (3) 3523-7581

© 2011 Atmel Corporation. All rights reserved. / Rev.: 0321N-EPROM-4/11

Atmel®, logo and combinations thereof, and others are registered trademarks or trademarks of Atmel Corporation or its subsidiaries. Other terms and product names may be trademarks of others.

Disclaimer: The information in this document is provided in connection with Atmel products. No license, express or implied, by estoppel or otherwise, to any intellectual property right is granted by this document or in connection with the sale of Atmel products. EXCEPT AS SET FORTH IN THE ATMEL TERMS AND CONDITIONS OF SALES LOCATED ON THE ATMEL WEBSITE, ATMEL ASSUMES NO LIABILITY WHATSOEVER AND DISCLAIMS ANY EXPRESS, IMPLIED OR STATUTORY WARRANTY RELATING TO ITS PRODUCTS INCLUDING, BUT NOT LIMITED TO, THE IMPLIED WARRANTY OF MERCHANTABILITY, FITNESS FOR A PARTICULAR PURPOSE, OR NON-INFRINGEMENT. IN NO EVENT SHALL ATMEL BE LIABLE FOR ANY DIRECT, INDIRECT, CONSEQUENTIAL, PUNITIVE, SPECIAL OR INCIDENTAL DAMAGES (INCLUDING, WITHOUT LIMITATION, DAMAGES FOR LOSS AND PROFITS, BUSINESS INTERRUPTION, OR LOSS OF INFORMATION) ARISING OUT OF THE USE OR INABILITY TO USE THIS DOCUMENT, EVEN IF ATMEL HAS BEEN ADVISED OF THE POSSIBILITY OF SUCH DAMAGES. Atmel makes no representations or warranties with respect to the accuracy or completeness of the contents of this document and reserves the right to make changes to specifications and products descriptions at any time without notice. Atmel does not make any commitment to update the information contained herein. Unless specifically provided otherwise, Atmel products are not suitable for, and shall not be used in, automotive applications. Atmel products are not intended, authorized, or warranted for use as components in applications intended to support or sustain life.

## Looking for pricing, stock, or lifecycle information?

Click below to explore more details on WIN SOURCE:

 [View AT27C010-45JU on WIN SOURCE](#)

 [Atmel Information](#)

## Optimize Your Supply Chain with WIN SOURCE Solutions

-  Global Sourcing Solution
-  Obsolete Management
-  Cost Control Management
-  Shortage Management
-  Alternative Solution
-  Excess Inventory Management