



**THE DATASHEET OF  
LT1777CS#PBF**



# Low Noise Step-Down Switching Regulator

## FEATURES

- Programmable di/dt Limit
- Internally Limited dV/dt
- High Input Voltage: 48V Max
- 700mA Peak Switch Rating
- True Current Mode Control
- 100kHz Fixed Operating Frequency
- Synchronizable to 250kHz
- Low Supply Current in Shutdown: 30 $\mu$ A
- Low Thermal Resistance 16-Pin SO Package

## APPLICATIONS

- Automotive Cellular and GPS Receivers
- Telecom Power Supplies
- Industrial Instrument Power Supplies

## DESCRIPTION

The LT<sup>®</sup>1777 is a Buck (step-down) regulator designed for noise sensitive applications. It contains a di/dt limiting circuit programmed via a small external inductor in the switching path. Internal circuitry also generates controlled dV/dt ramp rates.

The monolithic die includes all oscillator, control and protection circuitry. The part can accept operating input voltages as high as 48V, and contains an output switch rated at 700mA peak current. Current mode control offers excellent dynamic input supply rejection and short-circuit protection. The internal control circuitry is normally powered via the V<sub>CC</sub> pin, thereby minimizing power drawn directly from the V<sub>IN</sub> supply (see Applications Information). The fused-lead SO16 package and 100kHz switching frequency allow for minimal PC board area requirements.

LT, LTC and LT are registered trademarks of Linear Technology Corporation.

## TYPICAL APPLICATION

Low Noise 5V Step-Down Supply

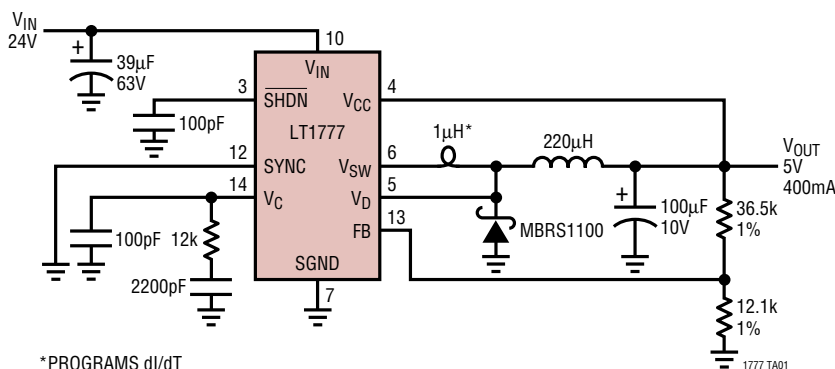

V<sub>SW</sub> Switching Waveforms

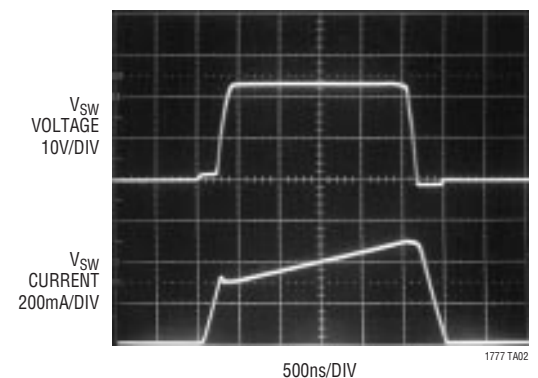

## ABSOLUTE MAXIMUM RATINGS

(Note 1)

Supply Voltage .....	48V
Switch Voltage ( $V_{IN} - V_{SW}$ ) (Note 4) .....	51V
SHDN, SYNC Pin Voltage .....	7V
$V_{CC}$ Pin Voltage .....	30V
FB Pin Voltage .....	3.0V
Operating Junction Temperature Range	
LT1777C .....	0°C to 125°C
LT1777I .....	-40°C to 125°C
Storage Temperature Range .....	-65°C to 150°C
Lead Temperature (Soldering, 10 sec) .....	300°C

## PACKAGE/ORDER INFORMATION

<p>TOP VIEW</p> <p>S PACKAGE 16-LEAD PLASTIC SO</p> <p><math>T_{JMAX} = 125^{\circ}C, \theta_{JA} = 50^{\circ}C/W^*</math></p>	<p>ORDER PART NUMBER</p> <p>LT1777CS LT1777IS</p> <p>* FOUR CORNER PINS ARE FUSED TO INTERNAL DIE ATTACH PADDLE FOR HEAT SINKING. CONNECT THESE FOUR PINS TO EXPANDED PC LANDS FOR PROPER HEAT SINKING.</p>
--	---

Consult factory for Military grade parts.

## ELECTRICAL CHARACTERISTICS

The ● denotes specifications which apply over the full operating temperature range, otherwise specifications are at  $T_J = 25^{\circ}C$ .  
 $V_{IN} = 24V, V_{SW} \text{ Open}, V_{CC} = 5V, V_C = 1.4V$  unless otherwise noted.

SYMBOL	PARAMETER	CONDITIONS	MIN	TYP	MAX	UNITS
<b>Power Supplies</b>						
$V_{IN(MIN)}$	Minimum Input Voltage			6.7	7.0 7.4	V
$I_{VIN}$	$V_{IN}$ Supply Current	$V_C = 0V$		620	800 900	$\mu A$ $\mu A$
$I_{VCC}$	$V_{CC}$ Supply Current	$V_C = 0V$		2.5	3.5 4.5	mA mA
$V_{VCC}$	$V_{CC}$ Dropout Voltage	(Note 2)		2.8	3.1	V
	Shutdown Mode $I_{VIN}$	$V_{SHDN} = 0V$		30	50 75	$\mu A$ $\mu A$
<b>Feedback Amplifier</b>						
$V_{REF}$	Reference Voltage		1.225 1.215	1.240	1.255 1.265	V V
$I_{IN}$	FB Pin Input Bias Current			600	1500	nA
$g_m$	Feedback Amplifier Transconductance	$\Delta I_C = \pm 10\mu A$	400 200	650	1000 1500	$\mu mho$ $\mu mho$
$I_{SRC}, I_{SNK}$	Feedback Amplifier Source or Sink Current		60 45	100	170 220	$\mu A$ $\mu A$
$V_{CL}$	Feedback Amplifier Clamp Voltage			2.0		V
	Reference Voltage Line Regulation	$12V \leq V_{IN} \leq 48V$			0.01	%/V
	Voltage Gain		200	600		V/V

## ELECTRICAL CHARACTERISTICS

The ● denotes specifications which apply over the full operating temperature range, otherwise specifications are at  $T_J = 25^\circ\text{C}$ .  
 $V_{IN} = 24\text{V}$ ,  $V_{SW}$  Open,  $V_{CC} = 5\text{V}$ ,  $V_C = 1.4\text{V}$  unless otherwise noted.

SYMBOL	PARAMETER	CONDITIONS		MIN	TYP	MAX	UNITS
<b>Output Switch</b>							
$R_{ON}$	Output Switch On Voltage	$I_{SW} = 0.5\text{A}$			1.0	1.5	V
$I_{LIM}$	Switch Current Limit	(Note 3)	●	0.55	0.70	1.0	A
	Output $dI/dt$ Sense Voltage		●	0.6	1.3	2.0	V
<b>Current Amplifier</b>							
	Control Pin Threshold	Duty Cycle = 0%		0.9	1.1	1.25	V
	Control Voltage to Switch Transconductance				2		A/V
<b>Timing</b>							
$f$	Switching Frequency		●	90	100	110	kHz
				85		115	kHz
	Maximum Switch Duty Cycle		●	85	90		%
<b>Sync Function</b>							
	Minimum Sync Amplitude		●		1.5	2.2	V
	Synchronization Range		●	130		250	kHz
	SYNC Pin Input R				40		$k\Omega$
<b>SHDN Pin Function</b>							
$V_{SHDN}$	Shutdown Mode Threshold		●	0.2	0.5	0.8	V
	Upper Lockout Threshold	Switching Action On			1.260		V
	Lower Lockout Threshold	Switching Action Off			1.245		V
$I_{SHDN}$	Shutdown Pin Current	$V_{SHDN} = 0\text{V}$ $V_{SHDN} = 1.25\text{V}$			12	20	$\mu\text{A}$
					2.5	10	$\mu\text{A}$

**Note 1:** Absolute Maximum Ratings are those values beyond which the life of a device may be impaired.

**Note 2:** Control circuitry powered from  $V_{CC}$ .

**Note 3:** Switch current limit is DC trimmed and tested in production. Inductor  $dI/dt$  rate will cause a somewhat higher current limit in actual application.

**Note 4:** During normal operation the  $V_{SW}$  pin may fly as much as 3V below ground. However, the LT1777 may not be used in an inverting DC/DC configuration.

# TYPICAL PERFORMANCE CHARACTERISTICS

**Minimum Input Voltage vs Temperature**

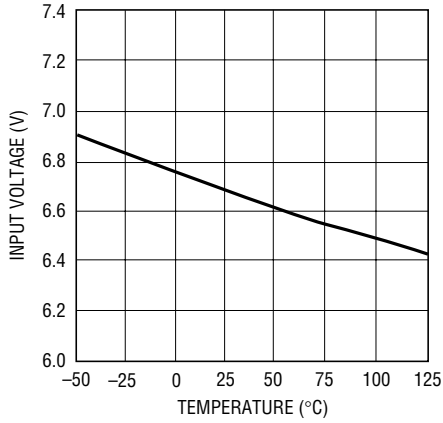

1777 G01

**Switch On Voltage vs Switch Current**

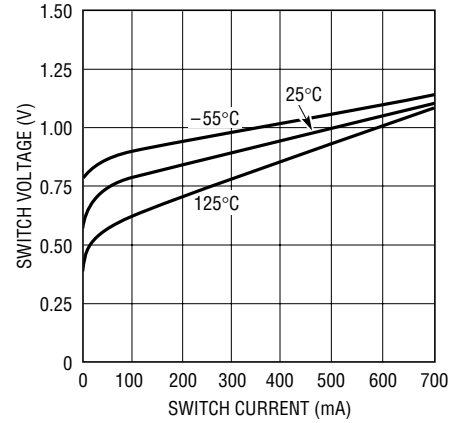

1777 G02

**Switch Current Limit vs Duty Cycle**

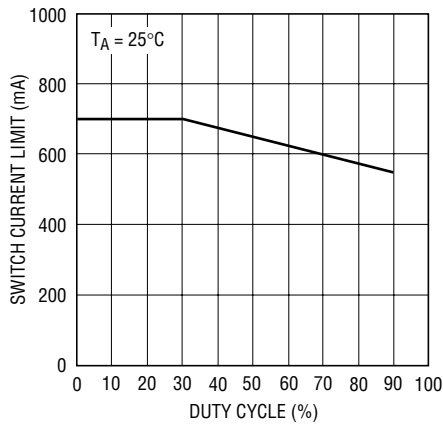

1777 G03

**SHDN Pin Shutdown Threshold vs Temperature**

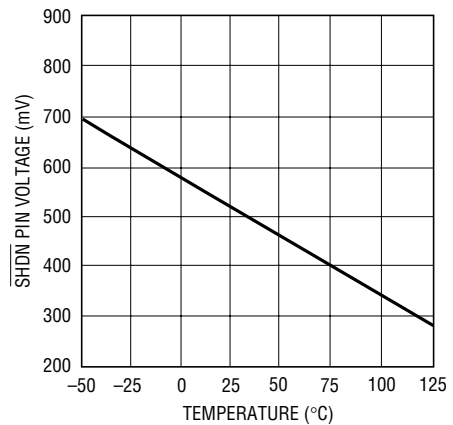

1777 G04

**SHDN Pin Current vs Voltage**

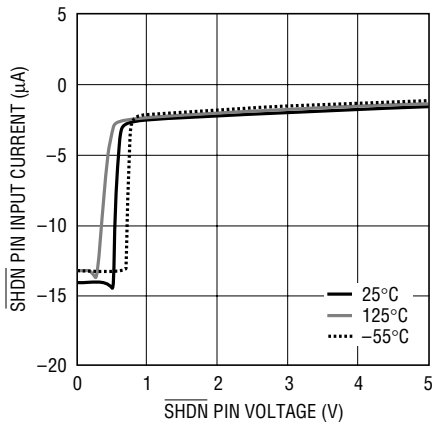

1777 G05

**SHDN Pin Lockout Thresholds vs Temperature**

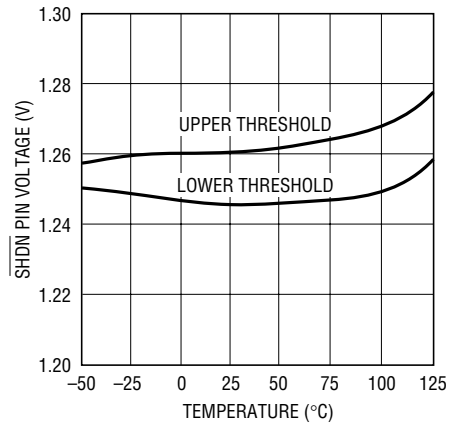

1777 G06

# TYPICAL PERFORMANCE CHARACTERISTICS

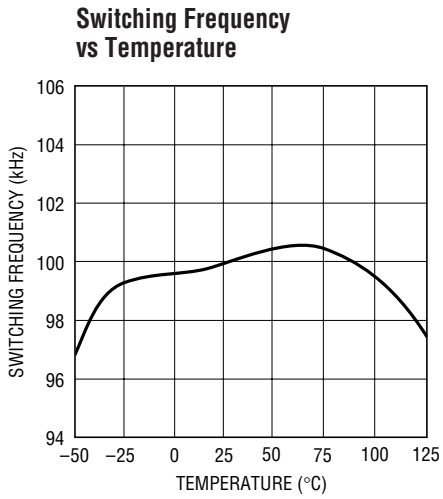

1777 G07

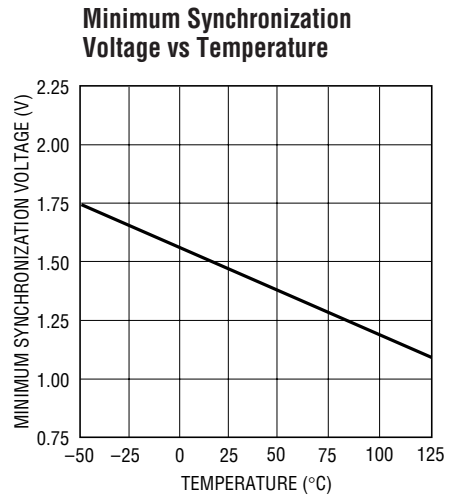

1777 G08

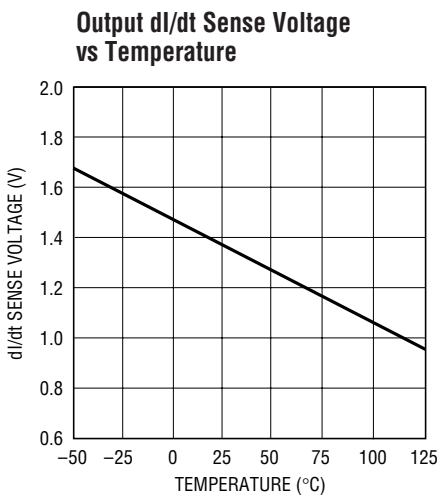

1777 G09

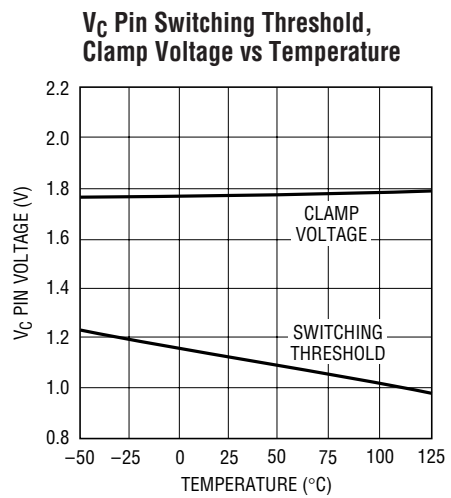

1777 G10

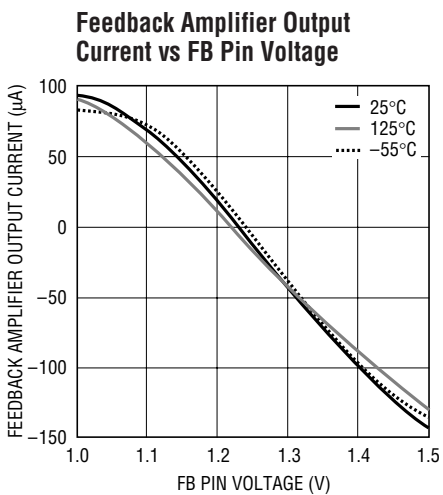

1777 G11

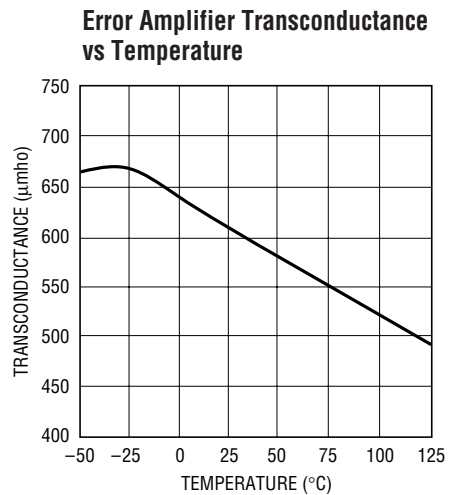

1777 G12

## PIN FUNCTIONS

**GND (Pins 1, 8, 9, 16):** These corner package pins are mechanically connected to the die paddle and thus aid in conducting away internally generated heat. As these are electrically connected to the die substrate, they must be held at ground potential. A direct connection to the local ground plane is recommended.

**NC (Pins 2, 11, 15):** Package Pins 2, 11 and 15 are unconnected.

**SHDN (Pin 3):** When pulled below the shutdown mode threshold, nominally 0.5V, this pin turns off the regulator and reduces  $V_{IN}$  input current to a few tens of microamperes (shutdown mode).

When this pin is held above the shutdown mode threshold, but below the lockout threshold, the part will be operational with the exception that output switching action will be inhibited (lockout mode). A user-adjustable undervoltage lockout can be implemented by driving this pin from an external resistor divider to  $V_{IN}$ . This action is logically “ANDed” with the internal UVLO, nominally set at 6.7V, such that minimum  $V_{IN}$  can be increased above 6.7V, but not decreased (see Applications Information).

If unused, this pin should be left open. However, the high impedance nature of this pin renders it susceptible to coupling from the  $V_{SW}$  node, so a small capacitor to ground, typically 100pF or so is recommended when the pin is left open.

**$V_{CC}$  (Pin 4):** Pin to power the internal control circuitry from the switching supply output. Proper use of this pin enhances overall power supply efficiency. During start-up conditions, internal control circuitry is powered directly from  $V_{IN}$ . If the output capacitor is located more than an inch from the  $V_{CC}$  pin, a separate 0.1 $\mu$ F bypass capacitor to ground may be required right at the pin.

**$V_D$  (Pin 5):** This pin is used in conjunction with a small external sense inductor to limit power path  $di/dt$ . The sense inductor is placed between the  $V_{SW}$  output node and the cathode of the freewheeling (power) diode, and the  $V_D$  pin is connected to the diode. As the voltage across the inductor reaches  $\pm 2V_{BE}$ , drive to the output transistor is

removed or supplied accordingly to limit  $di/dt$  (see Applications Information).

**$V_{SW}$  (Pin 6):** This is the emitter node of the output switch and has large currents flowing through it. Keep the traces to the switching components as short as possible to minimize electromagnetic radiation and voltage spikes.

**SGND (Pin 7):** This is the device signal ground pin. The internal reference and feedback amplifier are referred to it. Keep the ground path connection to the FB divider and the  $V_C$  compensation capacitor free of large ground currents.

**$V_{IN}$  (Pin 10):** This is the high voltage supply pin for the output switch. It also supplies power to the internal control circuitry during start-up conditions or if the  $V_{CC}$  pin is left open. A high quality bypass capacitor which meets the input ripple current requirements is needed here (see Applications Information).

**SYNC (Pin 12):** Pin to synchronize internal oscillator to external frequency reference. It is directly logic compatible and can be driven with any signal between 10% and 90% duty cycle. The sync function is internally disabled if the FB pin voltage is low enough to cause oscillator slowdown. If unused, this pin should be grounded.

**FB (Pin 13):** This is the inverting input to the feedback amplifier. The noninverting input of this amplifier is internally tied to the 1.24V reference. This pin also slows down the frequency of the internal oscillator when its voltage is abnormally low, e.g. 2/3 of normal or less. This feature helps maintain proper short-circuit protection. Coupling from high speed noise to this pin can cause irregular operation. (See Switch Node Considerations section.)

**$V_C$  (Pin 14):** This is the control voltage pin which is the output of the feedback amplifier and the input of the current comparator. Frequency compensation of the overall loop is effected by placing a capacitor (or in most cases a series R/C combination) between this node and ground. Coupling from high speed noise to this pin can cause irregular operation. (See Switch Node Considerations section.)

## BLOCK DIAGRAM

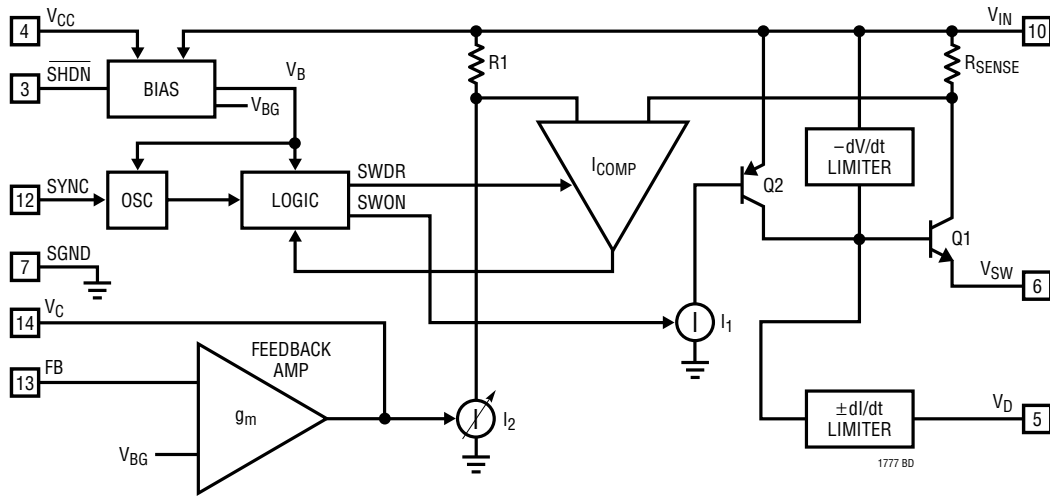

## OUTPUT STAGE SIMPLIFIED SCHEMATIC

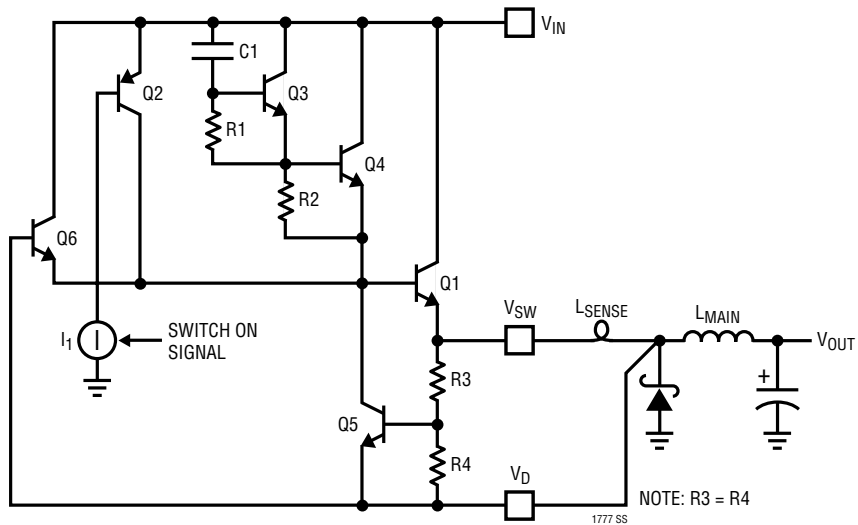

## OPERATION

The LT1777 is a current mode step-down switcher regulator IC designed for low noise operation. The Block Diagram shows an overall view of the system. The individual blocks are straightforward and similar to those found in traditional designs, including: Internal Bias Regulator, Oscillator, Logic, and Feedback Amplifier. The novel portion includes a specialized Output Switch section including circuits to limit the  $di/dt$  and  $dV/dt$  switching rates.

The LT1777 operates much the same as traditional current mode switchers, the major difference being its specialized output switch section. Due to space constraints, this discussion will not reiterate the basics of current mode switcher/controllers and the “buck” topology. A good source of information on these topics is Application Note AN19.

A straightforward output stage is provided by current source  $I_1$  driving the base of PNP transistor Q2. The collector of Q2 in turn drives the base of NPN output device Q1. The considerable base/collector capacitance of PNP Q2 acts to limit  $dV/dt$  rate during switch turn-on. However, when the switch is to be turned off, the only natural limit to voltage slew rate would be the collector/base capacitance of Q1 providing drive for the same device. While dependent upon output load level and Q1's  $\beta$ , the turn-off voltage slew rate would be typically much faster than the turn-on rate. To limit the voltage slew rate on switch turn-off, an extra function is supplied. This is denoted by the block labeled “ $-dV/dt$  Limiter.”

The details of the  $-dV/dt$  Limiter can be seen in the Output Stage Simplified Schematic. Transistors Q3 and Q4 are connected in a Darlington configuration whose input is

coupled with small-valued capacitor C1 to the  $V_{IN}$  supply rail. The product of negative voltage slew rate times this capacitor value equals current, and when this current through emitter/base resistor R1 exceeds a diode drop, Q3 and then Q4 turn on supplying base drive to output device Q1 to limit  $-dV/dt$  rate.

In addition to voltage rates, the current slew rate also needs to be controlled for reduced noise behavior. This is provided by the section in the Block Diagram labeled “ $\pm di/dt$  Limiter.” The details of this circuit can be seen in the Output Stage Simplified Schematic. Note that an extra, small-valued inductor, termed the “sense inductor” has been added to the classic buck topology. As this inductor is external to the LT1777, its value can be chosen by the user allowing for optimization on a per application basis. Operation of the current slew limiter is as follows: The product of the sense inductor times the  $di/dt$  through it generates a voltage according to the well known formula  $V = (L)(di/dt)$ . The remainder of the circuit is configured such that when the voltage across the sense inductor reaches  $\pm 2V_{BE}$ , drive current will be supplied or removed as necessary to limit current slew rate. The actual sensing is performed between the output node labeled  $V_{SW}$  and a new node labeled  $V_D$ .

In the case of switch turn-on, current drive is provided by PNP Q2. If the voltage at  $V_{SW}$  reaches  $2V_{BE}$  above that at  $V_D$ , transistor Q5 turns on and removes a portion of Q2's drive from Q1's base. Similarly for turn-off, as the  $V_{SW}$  node goes  $2V_{BE}$  below  $V_D$ , transistor Q6 then turns on to drive Q1's base as needed. The net effect is that of limiting the switch node  $di/dt$  in both directions at a rate inversely proportional to the external sense inductor value.

## APPLICATIONS INFORMATION

### Basics of Low Noise Operation

Switching power supply circuits are often preferred over linear topologies for their improved efficiency ( $P_{OUT}/P_{IN}$ ). However, their typically rapid voltage and current slew rates often cause “radio frequency” interference problems, commonly referred to as “RFI”. The LT1777 is designed to provide a less aggressive voltage slew rate and a user-programmable current slew rate to eliminate the highest frequency harmonics of RFI emissions. These highest frequency components are typically the most troublesome. Optimum behavior is obtained by a combination of proper circuit design, which includes passive component selection, and proper printed circuit board layout technique.

There are two types of RFI emissions, i.e., *conducted* and *radiated*. Conducted interference travels directly through “wires”, as opposed to radiated interference, which travels through the air. Conducted RFI can be created by a switching power supply at its input voltage supply node, its output node(s) or both. It is typically caused by pulsatile current flow through the residual high frequency impedance (ESR) of bypass capacitors.

Radiated interference can be of two types: electric (E field) or magnetic (B field). E field interference is caused by stray capacitance coupling of the node(s) which swing rapidly over a large voltage excursion. In the LT1777, this includes the  $V_{SW}$  and  $V_D$  nodes. E field radiation is kept low by minimizing the length and area of all traces connected to these nodes. A ground plane should always be used under the switcher circuitry to prevent interplane coupling. Although these nodes swing over a voltage range roughly equal to the input voltage, the limited  $dV/dt$  rate of the LT1777 reduces the highest frequency components of the generated E field RFI.

B field RFI is simply coupling of high frequency magnetic fields generated by the offending circuitry. High frequency magnetic fields are created by relatively rapidly changing currents, and the high speed current switching path in the LT1777 is shown schematically in Figure 1. This includes the input capacitor, output switch, sense inductor and output diode. Normal switching supply operation requires a rapid switching of current back and forth between the output switch and output diode. The LT1777 uses the

external sense inductor to set a maximum allowed  $dI/dt$  rate. This attenuates the highest frequency components of generated B field RFI. Minimal lead length in the path is also essential to minimize generated RFI.

A second potential source of magnetic RFI is the main (power) inductor. Fortunately, the natural triangular behavior of the current waveform in the main inductor tends to generate magnetic field energy concentrated in the fundamental and lower harmonics. Nevertheless, the relatively intense magnetic field present in the main inductor can cause coupling problems, especially if the main inductor is of an open construction type. So called rod or barrel inductors may be the physically smallest and most effective types, but their magnetic field extends far beyond the device itself. Closed type inductors, toroids for example, contain the magnetic field nearly completely. These are generally preferred for low noise behavior.

The sense inductor sees a much more rapid current slew rate than does the main inductor. However the sense inductor is physically smaller and of much lower inductance than the main inductor. These factors tend to reduce its propensity to generate magnetic interference problems. Nevertheless, more sensitive applications can opt for a closed type magnetic construction on the sense inductor.

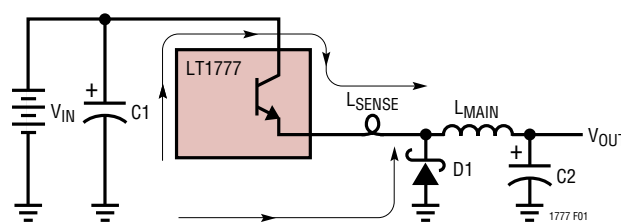

Figure 1. High Speed Current Switching Paths

### Selecting Sense Inductor

The LT1777 uses an external sense inductor to set a theoretical limit for current ramp rate according to the formula:

$$\text{Max } dI/dt = \frac{2V_{BE}}{L_{SENSE}}$$

## APPLICATIONS INFORMATION

Deciding upon a value for the sense inductor involves evaluating the trade-off between overall efficiency ( $P_{OUT}/P_{IN}$ ) and switch current slew rate. Larger sense inductors yield lower current slew rates which offer reduced high frequency RFI emissions, but at the expense of poorer efficiency.

The question is “What is the allowed range of values for a sense inductor in a given application?” There is really no *minimum* limit to the sense inductor, i.e., its value is allowed to be zero. (In other words, the physical sense inductor ceases to exist and is replaced by a short circuit.) This will yield the highest efficiency possible in a given situation. Although an explicit current slew rate no longer exists, the naturally less aggressive nature of the LT1777 will often yield quieter supply operation than other standard switching regulators.

As far as the *maximum* allowable value for the sense inductor, this is dictated by the current ramp rate in the main inductor during the conventional part of the switching cycle. It is generally overconservative to limit the switch current slew rate to that exhibited by the main inductor. This would potentially yield a triangular current waveform. Efficiency would be greatly reduced at little further gain in noise performance. Stated mathematically, maximum slew rate in the main inductor occurs at maximum input voltage as:

$$\frac{di}{dt} = \frac{\text{Max } V_{IN} - V_{OUT}}{L_{MAIN}}$$

The sense inductor experiences  $2V_{BE}$  of applied voltage. This is perhaps 1.0V at a maximum hot condition. If we use an additional factor of two to be conservative, this yields a maximum sense inductor value as follows:

$$\frac{0.5V}{L_{SENSE}} = \frac{\text{Max } V_{IN} - V_{OUT}}{L_{MAIN}} \quad \text{or,}$$

$$\text{Max } L_{SENSE} = L_{MAIN} \left( \frac{0.5V}{\text{Max } V_{IN} - V_{OUT}} \right)$$

As an example, a maximum input voltage of 36V, an output voltage of 5V and a main inductor value of  $220\mu\text{H}$  yields a maximum suggested sense inductor value of  $3.5\mu\text{H}$ .

Circuit behavior versus sense inductor value is shown in the oscilloscope photos in Figure 2. The circuit and operating conditions are similar to the Typical Application on the first page of this data sheet with the exception that the sense inductor is allowed to assume the series of values:  $0\mu\text{H}$ ,  $0.47\mu\text{H}$ ,  $1\mu\text{H}$  and  $2.2\mu\text{H}$ . Figure 2a shows a close-up of the leading edge (turn-on) of the current waveform. Values of  $0\mu\text{H}$  and  $0.47\mu\text{H}$  are found to yield a  $di/dt$  of about  $2.2\text{A}/\mu\text{s}$ , while  $1\mu\text{H}$  yields  $1.4\text{A}/\mu\text{s}$  and  $2.2\mu\text{H}$  yields  $0.6\text{A}/\mu\text{s}$ . Figure 2b shows the trailing edge (turn-off) of the

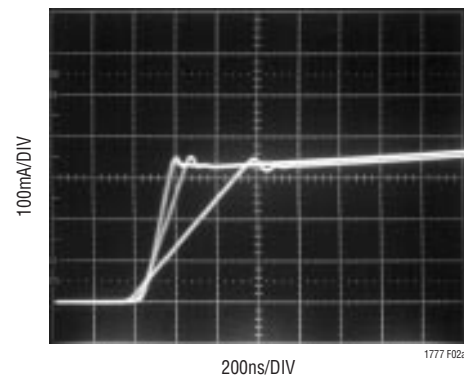

(a) Leading Edge

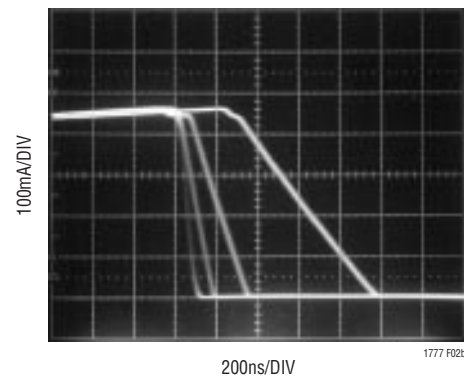

(b) Trailing Edge

Figure 2.  $V_{SW}$  Node Current Behavior vs  $L_{SENSE}$  Value.  $L_{SENSE} = 0\mu\text{H}, 0.47\mu\text{H}, 1.0\mu\text{H}$  and  $2.2\mu\text{H}$

## APPLICATIONS INFORMATION

current waveform. The four sense inductor values of 0μH, 0.47μH, 1μH and 2.2μH yield di/dt rates of roughly 4.5A/μs, 2.2A/μs, 1.4A/μs and 0.6A/μs, respectively.

These photos show that there is a minimum effective value for sense inductance, which is 0.47μH for a typical part at room temperature as shown. This value inductor has a small effect on the trailing edge rate, but essentially no effect on the rising edge. Minimum effective sense inductance value means that inductors much smaller than this value will have substantially the same performance as zero inductance, such that these inductors serve no useful purpose.

In summary,

1. The LT1777 uses an external sense inductor to set a theoretical limit for current ramp rate according to the formula:

$$\text{Max } di/dt = \frac{2V_{BE}}{L_{SENSE}}$$

2. Allowable range for the sense inductor runs from a minimum of 0 to a maximum of:

$$\text{Max } L_{SENSE} = L_{MAIN} \left( \frac{0.5V}{\text{Max } V_{IN} - V_{OUT}} \right)$$

3. The minimum effective inductor size is typically 0.47μH.

### Harmonic Behavior

The LT1676 is a high efficiency “cousin” to the LT1777. An additional set of oscilloscope photographs in Figure 3 show the leading edge and trailing edge of the current waveform when this part is substituted for the LT1777. (No sense inductor is used with the LT1676.) The leading and trailing edges of the LT1676 current waveform are much faster than that of the LT1777, even when the LT1777 uses a sense inductor of 0μH. The 10% to 90% rise time/fall time is on the order of 10ns to 20ns, too fast to measure accurately at the horizontal sweep rate of 200ns/DIV.

While this time-based analysis demonstrates that the current waveform of the LT1777 is quieter than standard high efficiency buck converters, some users may prefer to see a direct comparison on a frequency domain basis. Figures 4a, 4b, and 4c show a spectral analysis of the current waveforms. The horizontal axis is 2MHz/DIV (0MHz to 20MHz), and the vertical axis is 10dB/DIV. All photos were taken with  $V_{IN} = 24V$  and  $V_{OUT} = 5V$  at 400mA. Figure 4a is of the LT1676 and is for comparison purposes. Figures 4b and 4c are of the LT1777 with a sense inductor of 0μH and 2.2μH, respectively. A decrease in high frequency energy is seen when going from the LT1676 to the LT1777 with no sense inductor, and a further improvement with a 2.2μH sense inductor. For example, at 10MHz, the LT1777 shows an improvement of about -10dB with 0μH and perhaps -25dB with 2.2μH.

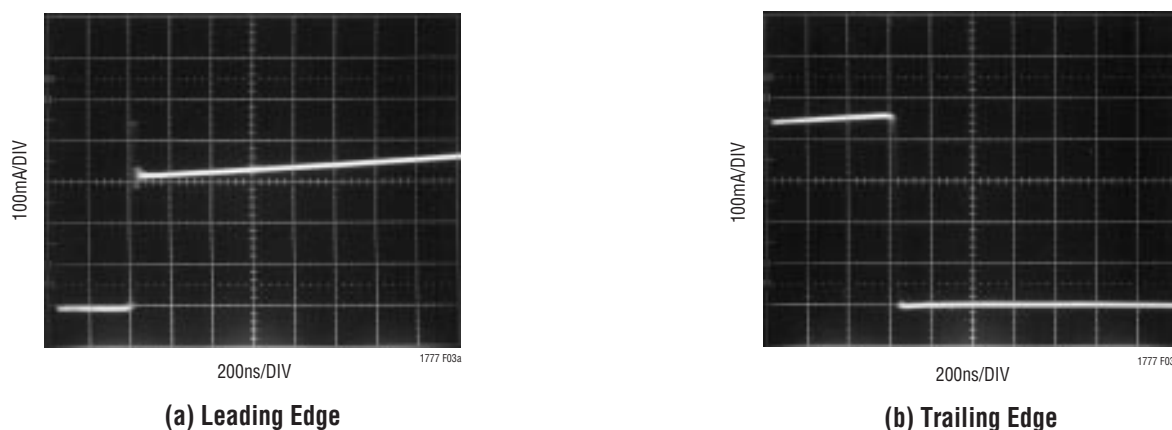
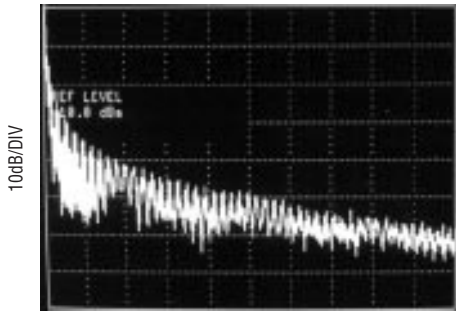
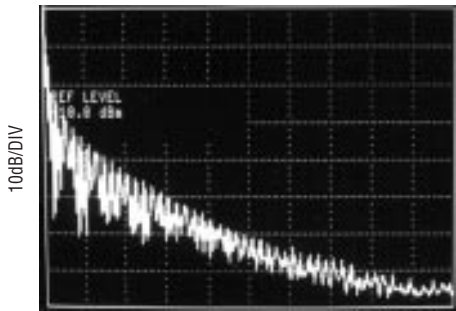

Figure 3. LT1676 Current Behavior for Comparison Purposes Only

**APPLICATIONS INFORMATION**



**(a) LT1676 for Comparison**



**(b) LT1777 with  $L_{SENSE} = 0\mu H$**

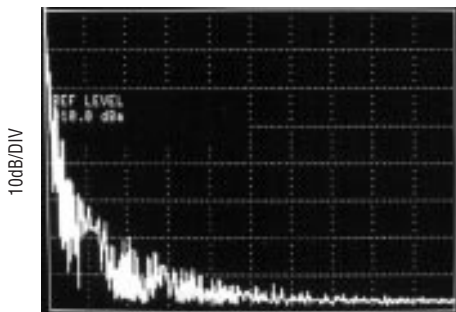

**(c) LT1777 with  $L_{SENSE} = 2.2\mu H$**

**Figure 4. Spectral Analysis of Current Waveforms in Figures 2 and 3. ( $V_{IN} = 24V$ ,  $V_{OUT} = 5V$ ,  $I_{OUT} = 400mA$ )**

**Voltage Waveform Behavior**

Unlike current behavior, voltage slew rate of the LT1777 is not adjustable by the user. No component selection or other action is required. Nevertheless, it is instructive to examine typical behavior. The oscilloscope photos in Figure 5 show the  $V_{SW}$  voltage waveform with an input

voltage of 12V, and then 36V. Once again the circuit is the Typical Application shown on the first page of this data sheet, with an output load of 400mA.

Figure 5a, with  $V_{IN}$  of 12V, shows a relatively rectangular voltage waveform. The limited voltage slew rate still allows for nearly vertical switching edges, so little power is wasted. A positive-going step before the leading edge and a negative-going step after the trailing edge can be seen. These are evidence of the internal current limiting circuitry at work.

Figure 5b, with  $V_{IN}$  of 36V, shows a substantially nonrectangular waveform. The limited voltage slew rate is clearly evident as transitions take a few hundred nanoseconds. Efficiency ( $P_{OUT}/P_{IN}$ ) is reduced as a result of the slower transitions. For comparison purposes, the oscilloscope photo in Figure 6 shows the performance of the high efficiency LT1676. Voltage transitions are well under 100ns and the waveform appears quite rectangular.

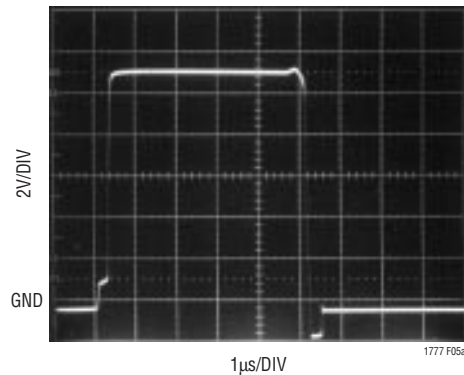

**(a)  $V_{IN} = 12V$**

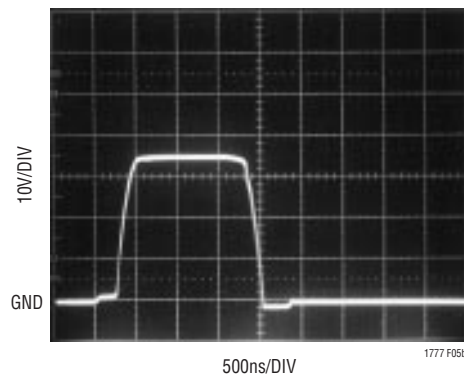

**(b)  $V_{IN} = 36V$**

**Figure 5.  $V_{SW}$  Node Voltage Behavior**

## APPLICATIONS INFORMATION

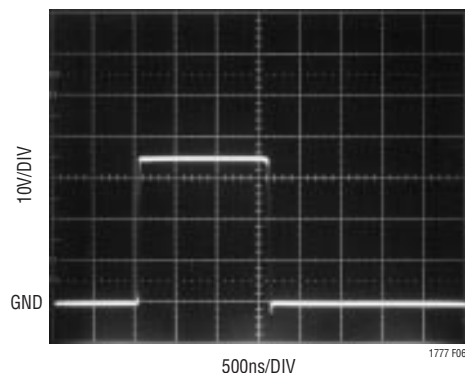

**Figure 6. LT1676  $V_{SW}$  Node Voltage Behavior for Comparison Purposes Only,  $V_{IN} = 36V$**

### Selecting Main Inductor

There are several parameters to consider when selecting a main inductor. These include inductance value, peak current rating (to avoid core saturation), DC resistance, construction type, physical size, and of course, cost.

Once the inductance value is decided, inductor peak current rating and resistance need to be considered. Here, the inductor peak current rating refers to the onset of saturation in the core material, although manufacturers sometimes specify a “peak current rating” which is derived from a worst-case combination of core saturation and self-heating effects. Inductor winding resistance alone limits the inductor’s current carrying capability as the  $I^2R$  power threatens to overheat the inductor. Remember to include the condition of output short circuit, if applicable. Although the peak current rating of the inductor can be exceeded in short-circuit operation, as core saturation per se is not destructive to the core, excess resistive self-heating is still a potential problem.

The final inductor selection is generally based on cost, which usually translates into choosing the smallest physical size part which meets the desired inductance value, resistance and current carrying capability. An additional factor to consider is that of physical construction. Briefly stated, “open” inductors built on a rod- or barrel-shaped core generally offer the smallest physical size and lowest cost. However their open construction does not contain the resulting magnetic field, and they may not be acceptable in RFI-sensitive applications. (A mitigating factor is that, as mentioned previously, the AC current passing

through the main inductor has most of its energy concentrated in the fundamental and lower harmonics.) Toroidal style inductors, many available in surface mount configuration, offer a reduced external magnetic field, generally at an increase in cost and physical size. Although custom design is always a possibility, most potential LT1777 applications can be handled by the array of standard, off-the-shelf inductor products offered by the major suppliers.

### Selecting Bypass Capacitors

The basic topology as shown in the Typical Application on the first page uses two bypass capacitors, one for the  $V_{IN}$  input supply and one for the  $V_{OUT}$  output supply.

User selection of an appropriate output capacitor is relatively easy, as this capacitor sees only the AC ripple current in the inductor L1. As the LT1777 is designed for buck or step-down applications, output voltage will nearly always be compatible with tantalum type capacitors, which are generally available in ratings up to 35V or so. These tantalum types offer good volumetric efficiency, and many are available with specified ESR performance. The product of inductor AC ripple current and output capacitor ESR will manifest itself as peak-to-peak voltage ripple on the output node. (Note: If this ripple becomes too large, heavier control loop compensation, at least at the switching frequency, may be required on the  $V_C$  pin.)

The input bypass capacitor can present a more difficult choice. In a typical application e.g.,  $24V_{IN}$  to  $5V_{OUT}$ , relatively heavy  $V_{IN}$  current is drawn by the power switch for only a small portion of the oscillator period (low ON duty cycle). The resulting RMS ripple current, for which the capacitor must be rated, can be several times the DC average  $V_{IN}$  current. The straightforward choice for a low volume, surface mountable electrolytic capacitor with good ESR/ripple current ratings is a tantalum type. However, worst-case (high) input voltage coupled with standard capacitor voltage derating may exceed the 35V or so for which tantalum capacitors are generally available. Relatively bulky “high frequency” aluminum electrolytic types, specifically constructed and rated for switching supply applications, may then be the only choice.

Additionally, it may be advantageous to parallel the input and output capacitors with 0.1 $\mu$ F ceramic bypass capaci-

## APPLICATIONS INFORMATION

tors. Their relatively low ESR in the mid-MHz region can further attenuate high speed glitches.

### Maximum Load/Short-Circuit Considerations

The LT1777 is a current mode controller. It uses the  $V_C$  node voltage as an input to a current comparator, which turns off the output switch on a cycle-by-cycle basis as this peak current is reached. The internal clamp on the  $V_C$  node, nominally 2.0V, then acts as an output switch peak current limit. This action becomes the switch current limit specification. The maximum available output power is then determined by the switch current limit.

A potential controllability problem could occur under short-circuit conditions. If the power supply output is short circuited, the feedback amplifier responds to the low output voltage by raising the control voltage,  $V_C$ , to its peak current limit value. Ideally, the output switch would be turned on, and then turned off as its current exceeded the value indicated by  $V_C$ . However, there is finite response time involved in both the current comparator and turn-off of the output switch. These result in a minimum on time  $t_{ON(MIN)}$ . When combined with the large ratio of  $V_{IN}$  to  $(V_F + I \cdot R)$ , the diode forward voltage plus inductor  $I \cdot R$  voltage drop, the potential exists for a loss of control. Expressed mathematically the requirement to maintain control is:

$$f(t_{ON}) \leq \frac{V_F + I \cdot R}{V_{IN}}$$

where:

$f$  = switching frequency

$t_{ON}$  = switch on time

$V_F$  = diode forward voltage

$V_{IN}$  = Input voltage

$I \cdot R$  = inductor  $I \cdot R$  voltage drop

If this condition is not observed, the current will not be limited at  $I_{PK}$ , but will cycle-by-cycle ratchet up to some higher value. Using the nominal LT1777 clock frequency of 100kHz, a  $V_{IN}$  of 48V and a  $(V_F + I \cdot R)$  of say, 0.7V, the maximum  $t_{ON}$  to maintain control would be approximately 140ns, an unacceptably short time.

The solution to this dilemma is to slow down the oscillator when the FB pin voltage is abnormally low thereby indicating some sort of short-circuit condition. Figure 7 shows the typical response of oscillator frequency vs FB pin voltage. Oscillator frequency is normal until FB voltage drops to about half of its normal value. Below this point the oscillator frequency decreases linearly down to a limit of about 25kHz. This lower oscillator frequency during short-circuit conditions can then maintain control with the effective minimum on time.

A further potential problem with short-circuit operation might occur if the user were operating the part with its oscillator slaved to an external frequency source via the SYNC pin. However, the LT1777 has circuitry to automatically disable the sync function when the oscillator is slowed down due to abnormally low FB voltage.

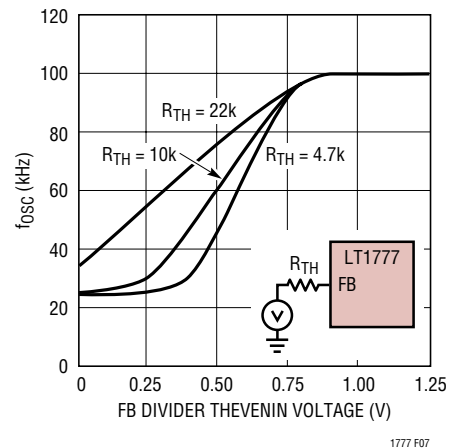

Figure 7. Oscillator Frequency vs FB Divider Thevenin Voltage and Impedance

### Feedback Divider Considerations

An LT1777 application typically includes a resistive divider between  $V_{OUT}$  and ground, the center node of which drives the FB pin to the reference voltage  $V_{REF}$ . This establishes a fixed ratio between the two resistors, but a second degree of freedom is offered by the overall impedance level of the resistor pair. The most obvious effect this has is one of efficiency—a higher resistance feedback divider will waste less power and offer somewhat higher efficiency, especially at light load.

## APPLICATIONS INFORMATION

However, remember that oscillator slowdown to achieve short-circuit protection (discussed above) is dependent on FB pin behavior, and this in turn, is sensitive to FB node external impedance. The graph in Figure 7 shows the typical relationship between FB pin voltage, driving impedance and oscillator frequency. This shows that as feedback network impedance increases beyond 10k, complete oscillator slowdown is not achieved, and short-circuit protection may be compromised. And as a practical matter, the product of FB pin bias current and larger FB network impedances will cause increasing output voltage error. (Nominal cancellation for 10k of FB Thevenin impedance is included internally.)

### Thermal Considerations

Care should be taken to ensure that the worst-case input voltage and load current conditions do not cause excessive die temperatures. The SO16 package is rated at 50°C/W when the four corner package pins are connected to a good ground plane. (These corner pins are internally fused to the die paddle for improved thermal performance.) Die junction temperature is then a function of ambient temperature and internal dissipation as follows:

$$T_J = T_A + \theta_{JA} \cdot P_{INT}$$

Total internally dissipated power is composed of three parts, quiescent power, DC switch loss and AC switch loss. The AC switch loss will often dominate the total dissipation, and this is unfortunately difficult to estimate accurately.

Two options are suggested to the potential user. The first is to observe the graphical data presented in the Typical Applications section. Internal LT1777 dissipation vs load current is given for output voltages of 5V and 3.3V, with input voltages of 12V, 24V and 36V, and with sense inductors of 0μH, 1μH, and 2.2μH (Figures 9 and 11). While it is true that the user's ultimate circuit may use somewhat different passive components than the examples given, it turns out that internal IC dissipation is not very sensitive to these changes.

In cases where the user's potential circuit differs significantly from the examples given, an empirical method is

suggested. Operate the proposed power supply over the applicable input voltage and load current ranges. Measure the input power and output power, and calculate the difference as "lost power." This measured lost power minus estimated inductor and diode dissipation yields a figure for internal LT1777 dissipation. Fortunately, as LT1777 internal dissipation dominates total lost power, inductor and diode power need not be estimated very accurately. Inductor power may be estimated as  $I^2R$  where  $I$  is the load current and  $R$  is the DC resistance of the inductor. (Loss in the sense inductor is usually so small that only the main inductor must be considered.) Diode power may be estimated as  $1/2 \cdot V_F \cdot I \cdot DC$ , where  $V_F$  is the diode forward voltage,  $I$  is the load current and  $DC$  is the duty cycle percentage when the diode is conducting.

### Frequency Compensation

Loop frequency compensation is performed by connecting a capacitor, or in most cases a series R/C, from the output of the error amplifier ( $V_C$  pin) to ground. Proper loop compensation may be obtained by empirical methods as described in detail in Application Note AN19. Briefly, this involves applying a load transient and observing the dynamic response over the expected range of  $V_{IN}$  and  $I_{LOAD}$  values.

As a practical matter, a second small capacitor, directly from the  $V_C$  pin to ground is generally recommended to attenuate capacitive coupling from the  $V_{SW}$  and  $V_D$  pins. A typical value for this capacitor is 100pF. (See Switch Node Considerations).

### Switch Node Considerations

In spite of the fact that the LT1777 is a low noise converter, it is still possible for the part to cause problems by "coupling to itself." Specifically, this can occur if the  $V_{SW}$  pin is allowed to capacitively couple in an uncontrolled manner to the part's high impedance nodes, i.e., SHDN, SYNC,  $V_C$  and FB. This can cause erratic operation such as odd/even cycle behavior, pulse width "nervousness", improper output voltage and/or premature current limit action.

## APPLICATIONS INFORMATION

As an example, assume that the capacitance between the  $V_{SW}$  node and a high impedance pin node is 0.1pF, and that the high impedance node in question exhibits a capacitance of 1pF to ground. Also assume a “typical” 36V<sub>IN</sub> to 5V<sub>OUT</sub> application. Due to the large voltage excursion at the  $V_{SW}$  node, this will couple a 3.5V(!) transient to the high impedance pin, causing abnormal operation. An explicit 100pF capacitor added to the node will reduce the amplitude of the disturbance to more like 35mV (although settling *time* will increase).

Specific pin recommendations are as follows:

$\overline{SHDN}$ : If unused, add a 100pF capacitor to ground.

SYNC: Ground if unused.

$V_C$ : Add a capacitor directly to ground in addition to the explicit compensation network. A value of one-tenth of the main compensation capacitor is recommended, up to a maximum of 100pF.

FB: Assuming the  $V_C$  pin is handled properly, this pin usually requires no explicit capacitor of its own, but keep this node physically small to minimize stray capacitance.

## TYPICAL APPLICATIONS

### Basic 5V Output Application

Figure 8 shows a basic application that produces 5V at up to 500mA  $I_{OUT}$ . Efficiency and Internal Power Dissipation graphs are shown in Figure 9 for input voltages of 12V, 24V and 36V, and for sense inductor values of 0 $\mu$ H, 1 $\mu$ H and 2.2 $\mu$ H. Be aware that continuous operation at the combination of high input voltage, large sense inductor and high output current may not be possible due to thermal constraints. (Brief transients in input voltage or

output current should not present a problem, though.) As shown, the  $\overline{SHDN}$  and SYNC pins are unused, however either (or both) can be optionally driven by external signals as desired.

The data as shown were performed using an off-the-shelf Coilcraft D03316-224 as the main inductor. This is a cost-effective inductor using an open style of construction. For a toroidal style inductor, the Coiltronics CTX250-4 or similar may be substituted.

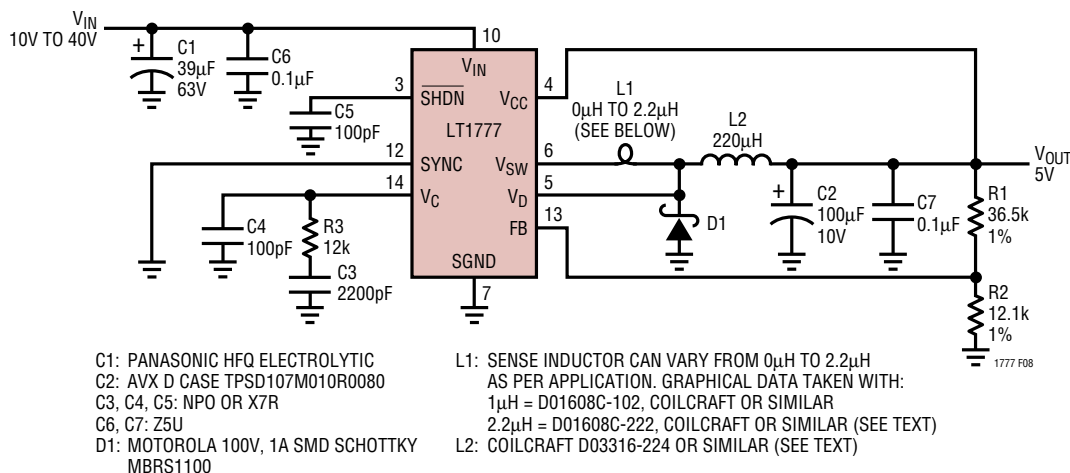

Figure 8. Basic 5V Output Application

TYPICAL APPLICATIONS

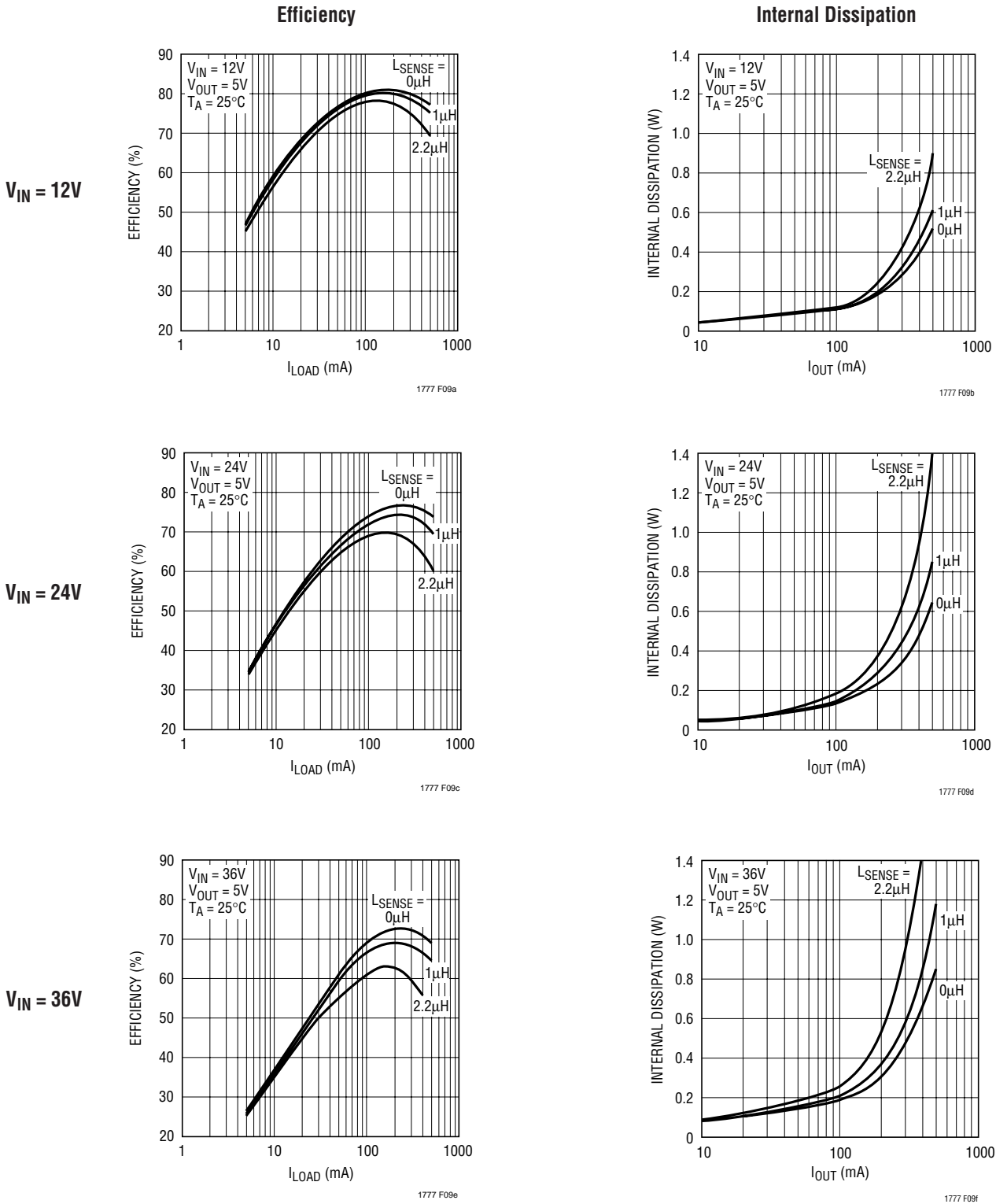

Figure 9. Efficiency and LT1777 Internal Dissipation for the Basic 5V Output Application

## TYPICAL APPLICATIONS

### Basic 3.3V Output Application

Figure 10 shows a circuit similar to the previous example, but modified for a 3.3V output. Once again, Efficiency and Internal Power Dissipation graphs are shown in Figure 11 for input voltages of 12V, 24V and 36V, and for sense inductor values of 0 $\mu$ H, 1 $\mu$ H and 2.2 $\mu$ H. It is interesting to note that internal LT1777 dissipation is very close to the 5V example. This confirms the fact that internal LT1777

dissipation is largely determined by input voltage, load current and sense inductor, and is only a weak function of output voltage.

The data as shown were performed using an off-the-shelf Coilcraft D03316-154 as the main inductor. This is a cost-effective inductor using an open style of construction. For a toroidal style inductor, the Coiltronics CTX150-4 or similar may be substituted.

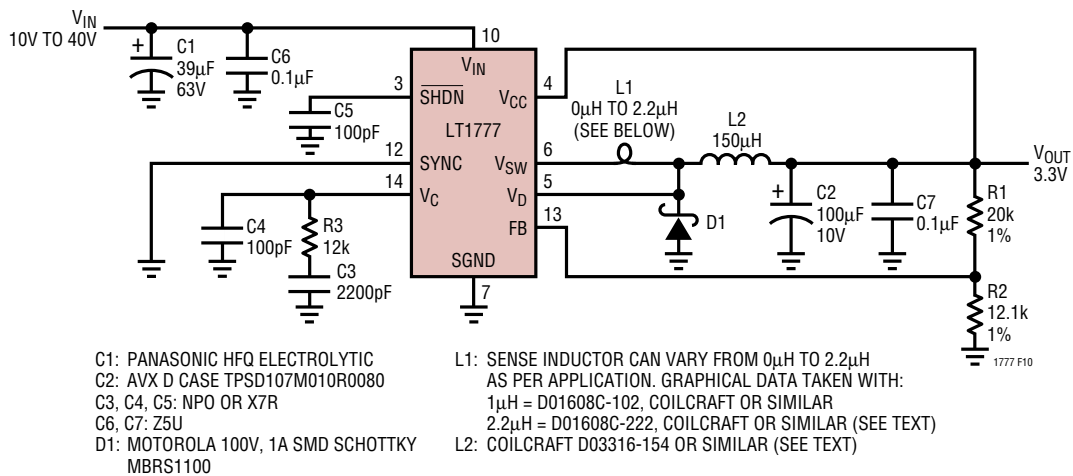

Figure 10. Basic 3.3V Output Application

TYPICAL APPLICATIONS

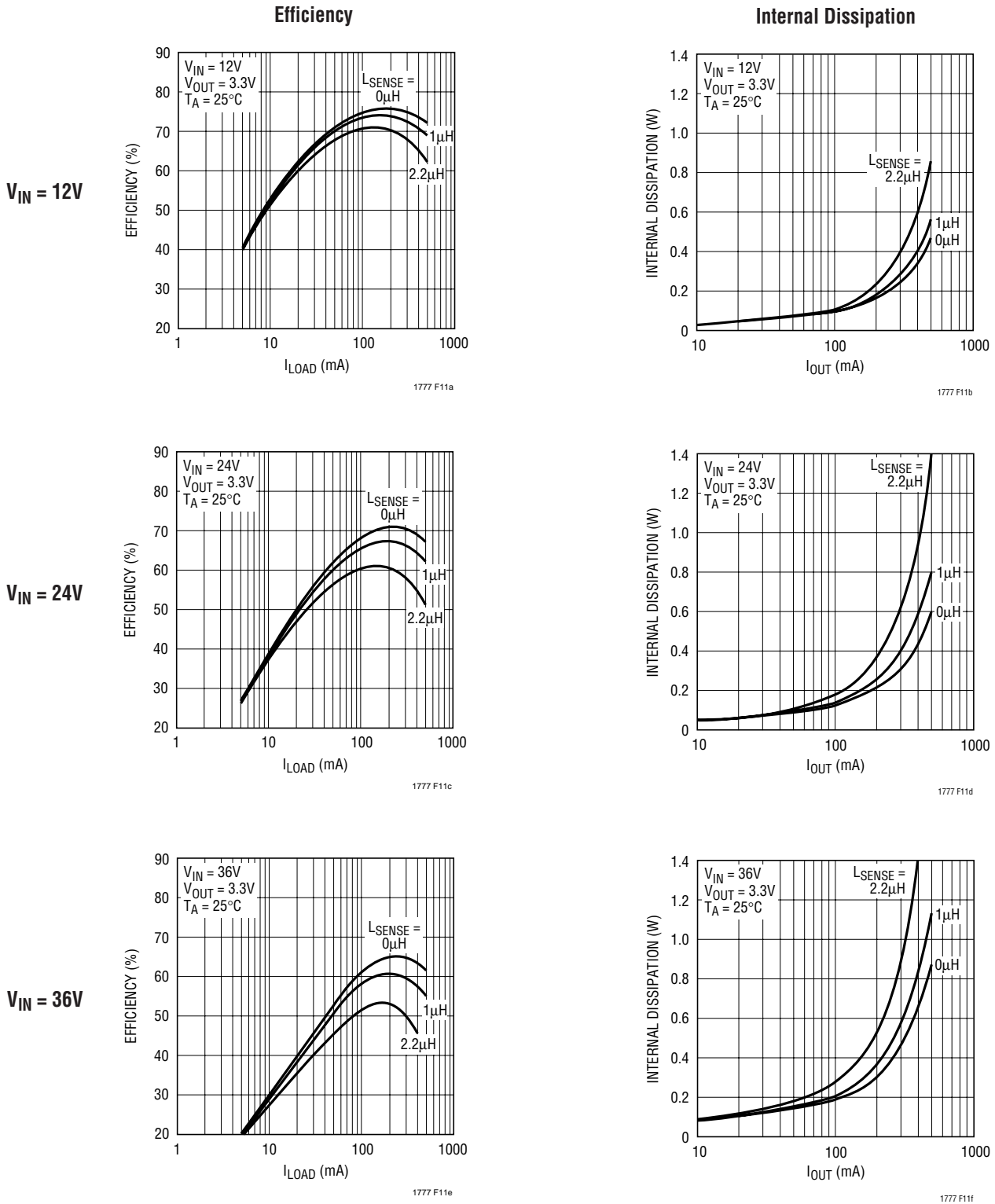

Figure 11. Efficiency and LT1777 Internal Dissipation for the Basic 3.3V Output Application

## TYPICAL APPLICATIONS

### Optional Input/Output Filtering

When minimum *conducted* noise is required, it is often advantageous to add an explicit input and/or output filter to the topology. This can be a cost-effective way to reduce conducted noise on the input or output node by an order of magnitude or more. The exact details involved are a bit lengthy, so the user is referred to the thorough treatments in Application Notes AN19 and AN44. However, an example will be given to illustrate the principles involved.

Figure 12 shows the previous “Basic 5V Output Application” modified with an additional input inductor and an output L/C combination. The dramatic improvement in noise performance is seen in the accompanying oscilloscope photos shown in Figures 13 and 14. Operating conditions are  $V_{IN} = 24V$ ,  $I_{OUT} = 400mA$ . The pair of scope photos in Figure 13 show the response at the input node, before and after the additional  $33\mu H$  inductor is added. The upper waveform shows an AC-coupled version of the

output voltage at  $50mV/DIV$ , and the lower waveform is a DC-coupled representation of current into the node at  $50mA/DIV$ . Input voltage ripple is seen to decrease from  $100mV_{P-P}$  to perhaps  $10mV_{P-P}$ . Ripple current is also seen to decrease dramatically. (This improvement in AC ripple current actually affects *radiated* magnetic noise.)

The next pair of scope photos in Figure 14 show an AC-coupled version of the output node at  $2mV/DIV$ . Voltage ripple is seen to be originally about  $12mV_{P-P}$ , with most of the energy in the lowest harmonics. After the addition of a  $4.7\mu H$  inductor and a second  $100\mu F$  output capacitor, ripple is about  $200\mu V_{P-P}$ .

These input and output inductor requirements are typically not very difficult to achieve, and inexpensive open style DO1608C types were used in this example. Once again, more costly closed-construction style inductors may be employed, but these are usually not necessary, as the AC fields generated by these inductors are typically small.

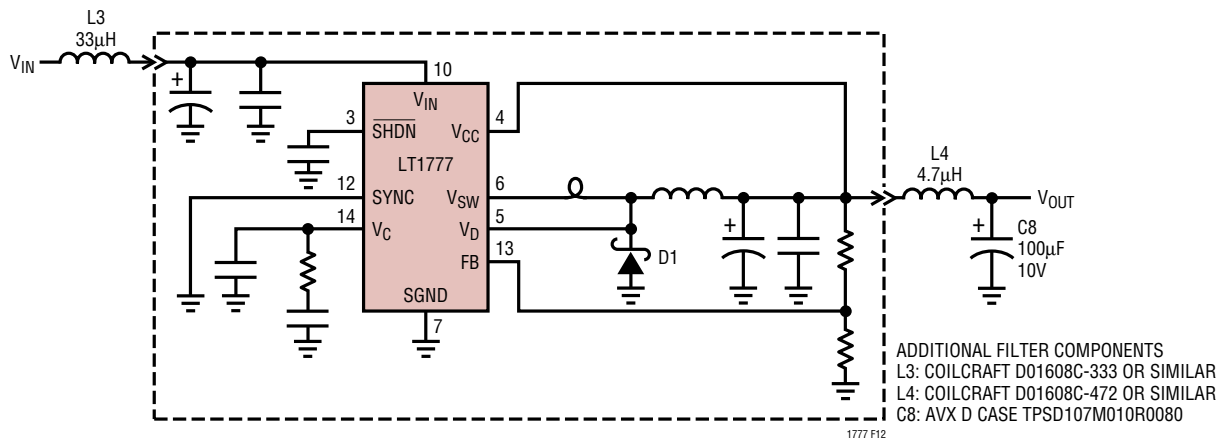

Figure 12. Basic 5V Application with Optional Input/Output Filters

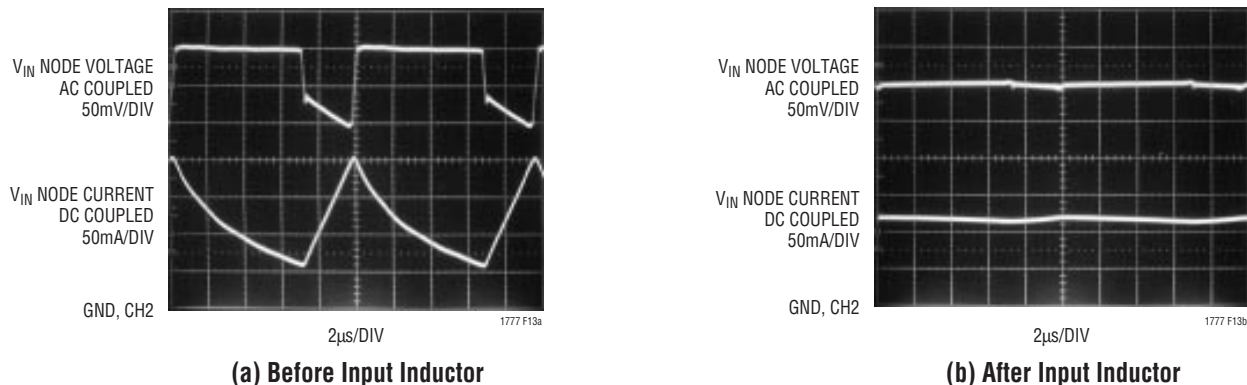

Figure 13. Input Node Ripple

## TYPICAL APPLICATIONS

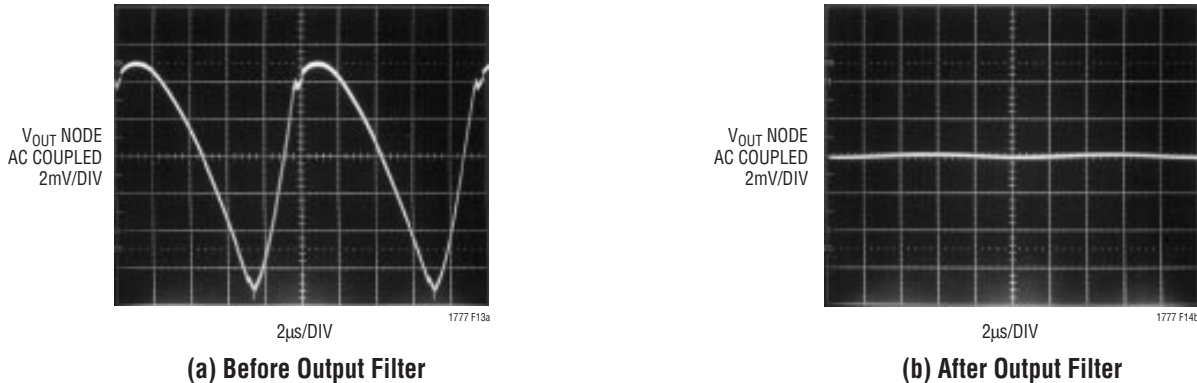

Figure 14. Output Node Ripple

### User Programmable Undervoltage Lockout

Figure 15 uses a resistor divider between  $V_{IN}$  and ground to drive the SHDN node. This is a simple, cost-effective way to add a user-programmable undervoltage lockout (UVLO) function. Resistor R5 is chosen to have approximately  $200\mu A$  through it at the nominal SHDN pin lockout threshold of roughly 1.25V. The somewhat arbitrary value of  $200\mu A$  was chosen to be significantly above the SHDN pin input current to minimize its error contribution, but significantly below the typical 2.5mA the LT1777 draws in lockout mode. Resistor R4 is then chosen to yield this same  $200\mu A$ , less  $2.5\mu A$ , with the desired  $V_{IN}$  UVLO voltage minus 1.25V across it. (The  $2.5\mu A$  factor is an allowance to minimize error due to SHDN pin input current.)

Behavior is as follows: Normal operation is observed at the nominal input voltage of 24V. As the input voltage is decreased to roughly 18V, switching action will stop,  $V_{OUT}$  will drop to zero, and the LT1777 will draw its  $V_{IN}$  and  $V_{CC}$  quiescent currents from the  $V_{IN}$  supply. At a lower input voltage, typically 10V or so at  $25^\circ C$ , the voltage on the SHDN pin will drop to the shutdown threshold, and the part will draw its shutdown current only from the  $V_{IN}$  rail. The resistive divider of R4 and R5 will continue to draw power from  $V_{IN}$ . (The user should be aware that while the SHDN pin *lockout* threshold is relatively accurate including temperature effects, the SHDN pin shutdown threshold is more coarse, and exhibits considerably more temperature drift. Nevertheless the *shutdown* threshold will always be well below the lockout threshold.)

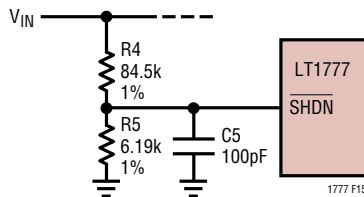
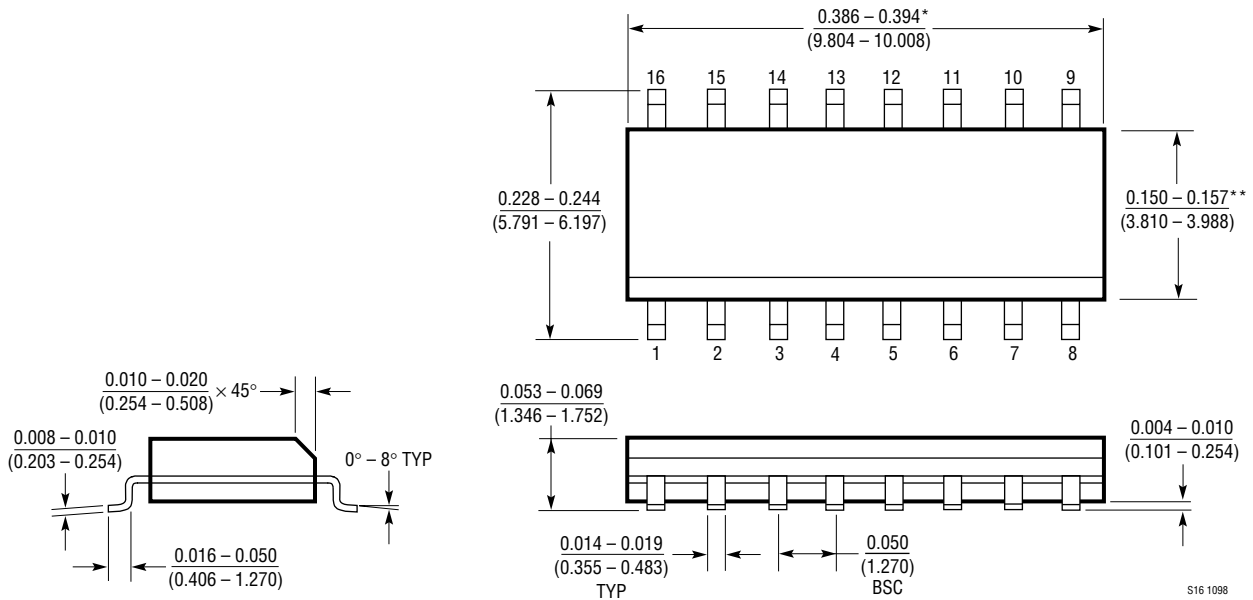

Figure 15. User Programmable UVLO

**PACKAGE DESCRIPTION** Dimensions in inches (millimeters) unless otherwise noted.

**S Package**  
**16-Lead Plastic Small Outline (Narrow 0.150)**  
 (LTC DWG # 05-08-1610)



\*DIMENSION DOES NOT INCLUDE MOLD FLASH. MOLD FLASH SHALL NOT EXCEED 0.006" (0.152mm) PER SIDE

\*\*DIMENSION DOES NOT INCLUDE INTERLEAD FLASH. INTERLEAD FLASH SHALL NOT EXCEED 0.010" (0.254mm) PER SIDE

## TYPICAL APPLICATION

### Minimum PC Board Size Application

The previously described basic applications employ power path parts which are capable of delivering the full rated input supply voltage and output current capabilities of the LT1777. A substantial improvement in printed circuit board area requirements can be achieved with the circuit shown below. This uses a physically smaller and less costly power inductor and a tantalum input capacitor. This

circuit is capable of delivering up to 300mA at 5V, from input voltages as high as 28V. The only disadvantage is that due to the increased resistance in the inductor, the circuit is no longer capable of withstanding indefinite short circuits to ground. The LT1777 will still current limit at its nominal  $I_{LIM}$  value, but this will overheat the inductor. Momentary short circuits of a few seconds or less can still be tolerated.

Minimum PC Board Area Application

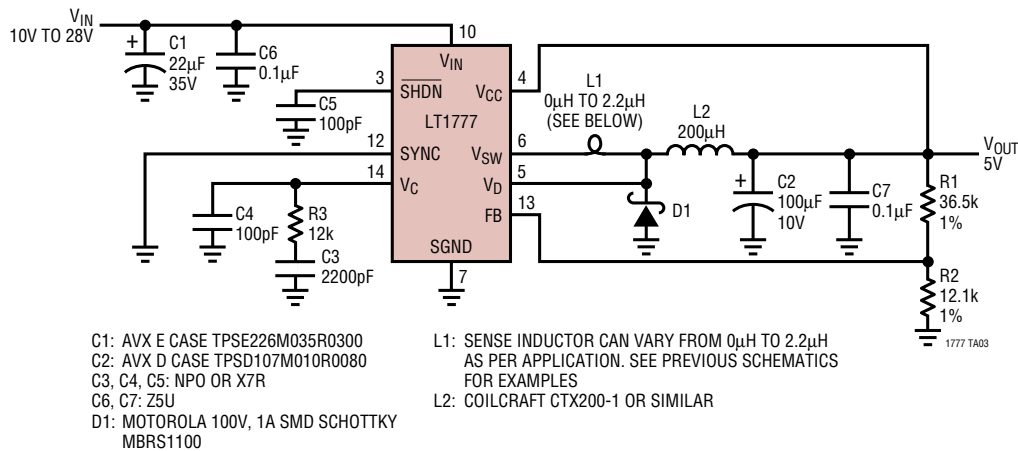

## RELATED PARTS

PART NUMBER	DESCRIPTION	COMMENTS
LT1076	100kHz, 2A Step-Down Switching Regulator	Integrated 2A Switch, $V_{IN}$ Up to 46V
LT1533	Ultralow Noise 1A Switching Regulator	Push-Pull Design for Low Noise Isolated Supplies
LT1534	Ultralow Noise 2A Switching Regulator	Ultralow Noise Regulator for Boost Topologies
LT1576	200kHz, 1.5A Step-Down Switching Regulator	Output Up to 1.25A, Integrated Switch, SO-8 Package
LTC1622	Low $V_{IN}$ Step-Down DC/DC Controller	Fixed Frequency 550kHz Operation, MSOP Package
LTC1624	High Efficiency SO-8 DC/DC Controller	200kHz Operation, $V_{IN}$ from 3.5V to 36V, SO-8 Package
LT1676/LT1776	Wide Input Range, High Efficiency, Step-Down Voltage Regulator	7.4V to 60V Input, 100/200kHz Operation, 700mA Internal Switch

## Looking for pricing, stock, or lifecycle information?

Click below to explore more details on WIN SOURCE:

 [View LT1777CS#PBF on WIN SOURCE](#)

 [Linear Technology](#) Information

## Optimize Your Supply Chain with WIN SOURCE Solutions

-  Global Sourcing Solution
-  Obsolete Management
-  Cost Control Management
-  Shortage Management
-  Alternative Solution
-  Excess Inventory Management