



**THE DATASHEET OF  
NCN3411MTTWG**



# NCN3411

## 4-Differential Channel 1:2 Mux/Demux Switch for PCI Express Gen3

The NCN3411 is a 4-Channel differential SPDT switch designed to route PCI Express Gen3 signals. When used in a PCI Express application, the switch can handle up to two PCIe lanes. Due to the ultra-low ON-state capacitance (2 pF typ) and resistance (7.5 Ω typ), these switches are ideal for switching high frequency data signals up to a signal bit rate of 8 Gbps. This switch pinout is designed to be used in BTX form factor desktop PCs and is available in a space-saving 3.5 x 9 x 0.75 mm WQFN42 package.

### Features

- V<sub>DD</sub> Power Supply from 1.5 V to 2.0 V
- 4 Differential Channels 2:1 MUX/DEMUX
- Compatible with PCIe 3.0
- Data Rate: Supports 8 Gbps
- Low Crosstalk -30 dB @ 4 GHz
- Low Bit-to-Bit Skew: 5 ps
- Low R<sub>ON</sub> Resistance: 13 Ω max
- Low C<sub>ON</sub> Capacitance: 2 pF
- Low Supply Current: 200 μA
- Off Isolation: -20 dB @ 4 GHz
- Space Saving Small WQFN-42 Package
- This is a Pb-Free Device

### Typical Applications

- Notebook Computer
- Desktop computer
- Server/Storage Area Network

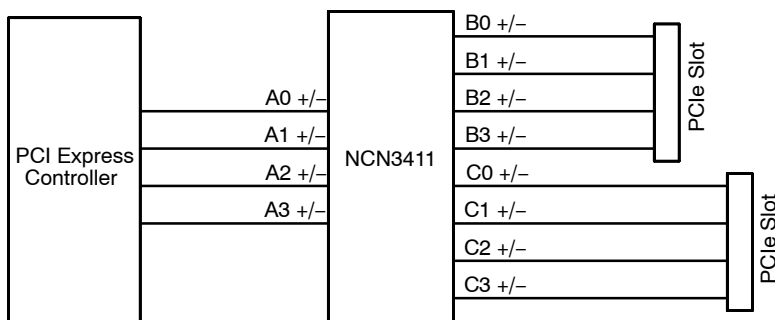
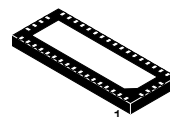

Figure 1. Application Schematic



ON Semiconductor®

<http://onsemi.com>



WQFN42  
CASE 510AP

### MARKING DIAGRAM

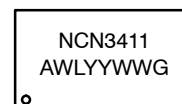

XXXXX = Specific Device Code  
 A = Assembly Location  
 WL = Wafer Lot  
 YY = Year  
 WW = Work Week  
 G = Pb-Free Package

### ORDERING INFORMATION

Device	Package	Shipping†
NCN3411MTTWG	WQFN42 (Pb-Free)	2000 / Tape & Reel

†For information on tape and reel specifications, including part orientation and tape sizes, please refer to our Tape and Reel Packaging Specifications Brochure, BRD8011/D.

# NCN3411

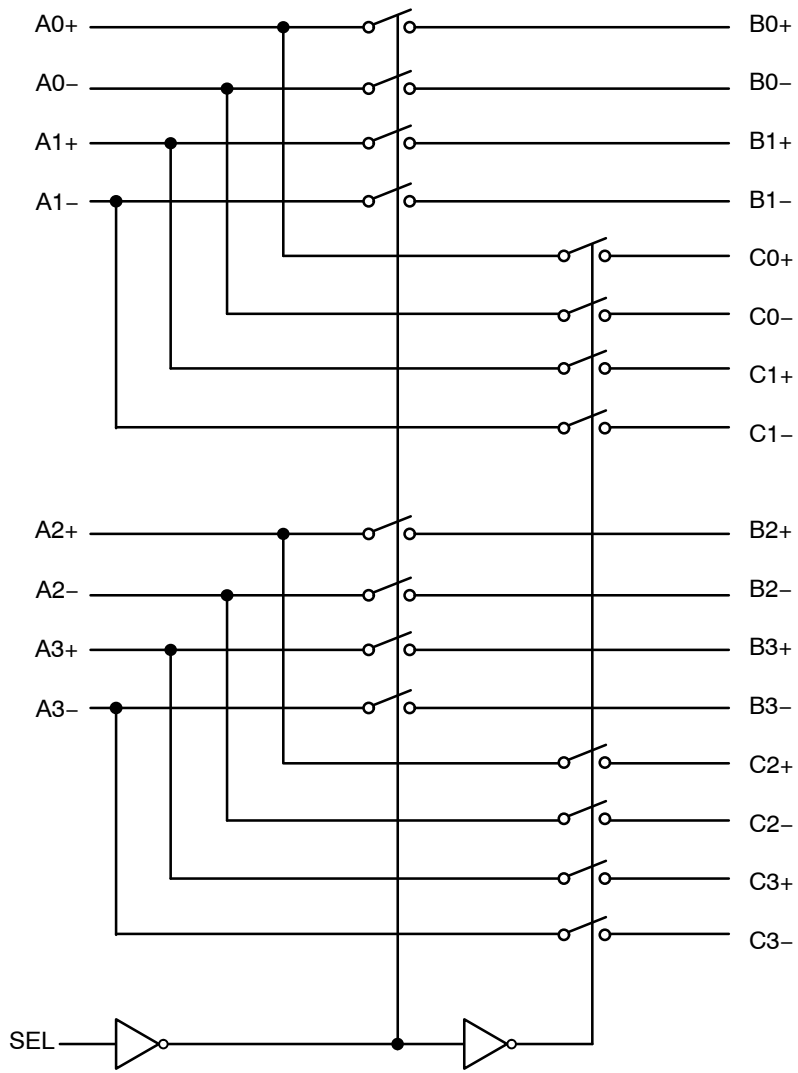

**Figure 2. NCN3411 Functional Block Diagram (Top View)**

## TRUTH TABLE

Function	SEL
$A_N$ to $B_N$	L
$A_N$ to $C_N$	H

# NCN3411

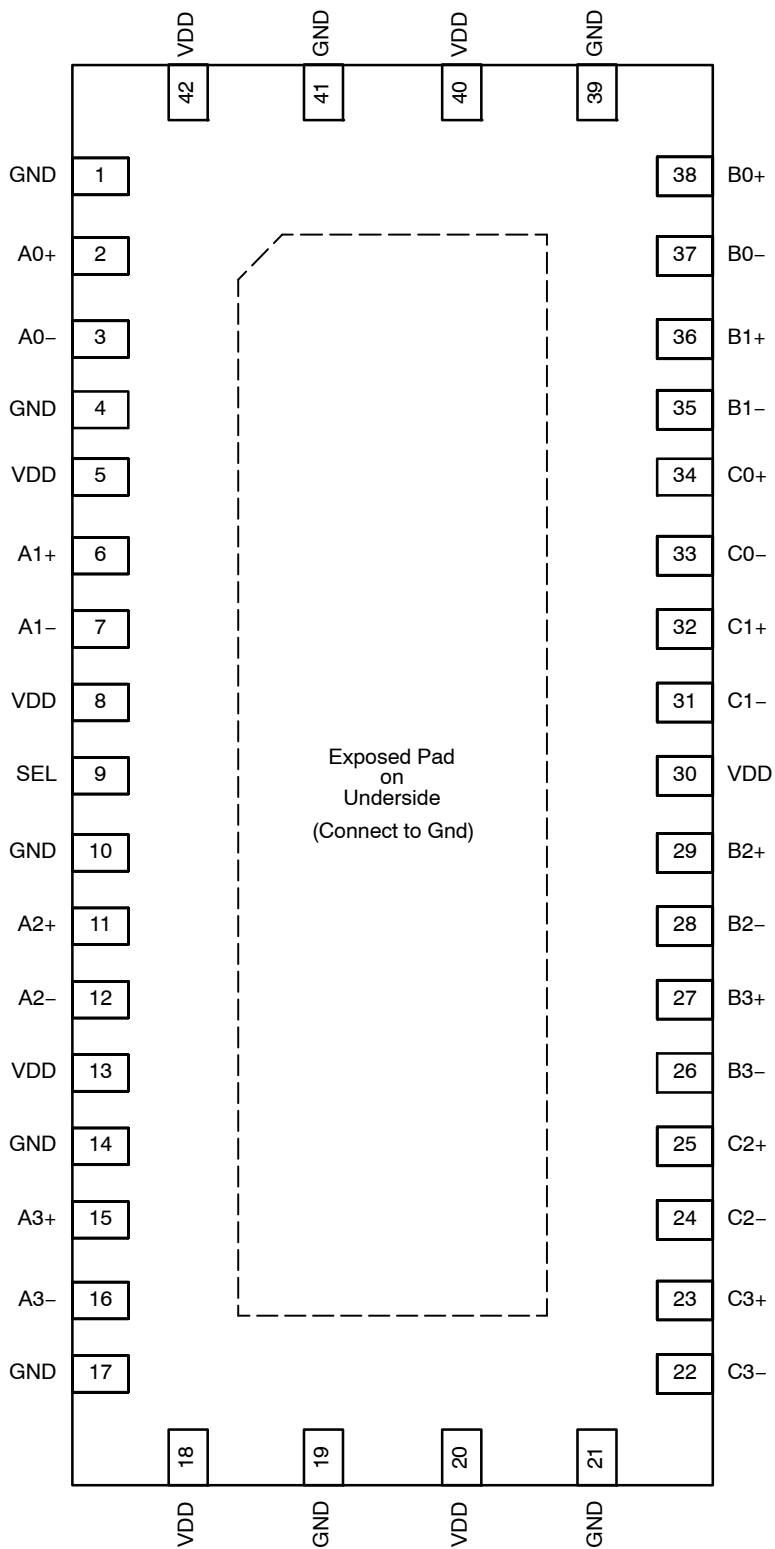

Figure 3. Pin Description (Top View)

# NCN3411

## PIN FUNCTION AND DESCRIPTION

Pin	Pin Name	Description
2 3	A0+ A0-	Signal I/O, Channel 0, Port A
6 7	A1+ A1-	Signal I/O, Channel 1, Port A
11 12	A2+ A2-	Signal I/O, Channel 2, Port A
15 16	A3+ A3-	Signal I/O, Channel 3, Port A
38 37	B0+ B0-	Signal I/O, Channel 0, Port B
36 35	B1+ B1-	Signal I/O, Channel 1, Port B
29 28	B2+ B2-	Signal I/O, Channel 2, Port B
27 26	B3+ B3-	Signal I/O, Channel 3, Port B
34 33	C0+ C0-	Signal I/O, Channel 0, Port C
32 31	C1+ C1-	Signal I/O, Channel 1, Port C
25 24	C2+ C2-	Signal I/O, Channel 2, Port C
23 22	C3+ C3-	Signal I/O, Channel 3, Port C
9	SEL	Operational Mode Select (When SEL = 0: A → B, When SEL = 1: A → C)
5, 8, 13, 18, 20, 30, 40, 42	VDD	DC Supply: 1.5 V to 2.0 V
1, 4, 10, 14, 17, 19, 21, 39, 41	GND	Power Ground
Exposed Pad	-	The exposed pad on the backside of package is internally connected to GND. Externally the pad should also be user-connected to GND.

# NCN3411

## MAXIMUM RATINGS

Parameter	Symbol	Rating	Units
Power Supply Voltage	$V_{DD}$	-0.5 to 2.5	$V_{DC}$
Input/Output Voltage Range of the Switch ( $A_N$ , $B_N$ , $C_N$ )	$V_{IS}$	-0.5 to $V_{DD}$	$V_{DC}$
Selection Pin Voltages	$V_{SEL}$	-0.5 to $V_{DD}$	$V_{DC}$
Continuous Current Through One Switch	$I_{CC}$	$\pm 120$	mA
Maximum Junction Temperature (Note 1)	$T_J$	150	$^{\circ}C$
Operating Ambient Temperature	$T_A$	-40 to +85	$^{\circ}C$
Storage Temperature Range	$T_{stg}$	-65 to +150	$^{\circ}C$
Thermal Resistance, Junction-to-Air	$R_{\theta JA}$	75	$^{\circ}C/W$
Latch-up Current (Note 2)	$I_{LU}$	$\pm 100$	mA
Human Body Model (HBM) ESD Rating (Note 3)	ESD HBM	7000	V
Machine Model (MM) ESD Rating (Note 3)	ESD MM	400	V
Moisture Sensitivity (Note 4)	MSL	Level 1	-

Stresses exceeding Maximum Ratings may damage the device. Maximum Ratings are stress ratings only. Functional operation above the Recommended Operating Conditions is not implied. Extended exposure to stresses above the Recommended Operating Conditions may affect device reliability.

1. Power dissipation must be considered to ensure maximum junction temperature ( $T_J$ ) is not exceeded.
2. Latch up Current Maximum Rating:  $\pm 100$  mA per JEDEC standard: JESD78.
3. This device series contains ESD protection and passes the following tests:  
 Human Body Model (HBM)  $\pm 7.0$  kV per JEDEC standard: JESD22-A114 for all pins.  
 Machine Model (MM)  $\pm 400$  V per JEDEC standard: JESD22-A115 for all pins.
4. Moisture Sensitivity Level (MSL): 1 per IPC/JEDEC standard: J-STD-020A.

# NCN3411

## DC ELECTRICAL CHARACTERISTICS OVER OPERATING RANGE ( $T_A = -40^{\circ}\text{C}$ to $+85^{\circ}\text{C}$ , $V_{DD} = 1.5\text{ V}$ to $2.0\text{ V}$ , $\text{GND} = 0\text{V}$ )

Symbol	Pins	Parameters	Conditions (Note 5)	Min.	Typ (Note 6)	Max.	Units
--------	------	------------	---------------------	------	--------------	------	-------

### POWER SUPPLY

$V_{DD}$	$V_{DD}$ , GND	Supply Voltage Range	With respect to GND	1.5	1.8	2.0	V
$I_{DD}$	$V_{DD}$ , GND	Quiescent Supply Current	$V_{DD} = 2\text{ V}$ , $V_{SEL} = \text{GND}$ or $V_{DD}$		200	300	$\mu\text{A}$

### DATA SWITCH PERFORMANCE

$V_{IS}$	$A_N$ , $B_N$ , $C_N$	Data Input/Output Voltage Range		0		1.2	V
$R_{ON}$	$B_N$	On Resistance ( $B_N$ )	$V_{DD} = 1.5\text{ V}$ , $V_{IS} = 0\text{ V}$ to $1.2\text{ V}$ , $I_{IS} = 15\text{ mA}$		7.5	13	$\Omega$
$R_{ON}$	$C_N$	On Resistance ( $C_N$ )	$V_{DD} = 1.5\text{ V}$ , $V_{IS} = 0\text{ V}$ to $1.2\text{ V}$ , $I_{IS} = 15\text{ mA}$		8.0	13	$\Omega$
$R_{ON(\text{flat})}$	$B_N$	On Resistance Flatness	$V_{DD} = 1.5\text{ V}$ , $V_{IS} = 0\text{ V}$ to $1.2\text{ V}$ , $I_{IS} = 15\text{ mA}$ (Note 7)		0.1	1.24	$\Omega$
$R_{ON(\text{flat})}$	$C_N$	On Resistance Flatness	$V_{DD} = 1.5\text{ V}$ , $V_{IS} = 0\text{ V}$ to $1.2\text{ V}$ , $I_{IS} = 15\text{ mA}$ (Note 7)		0.1	1.24	$\Omega$
$\Delta R_{ON}$	$B_N$	On Resistance Matching( $B_N$ )	$V_{DD} = 1.5\text{ V}$ , $V_{IS} = 0\text{ V}$ , $I_{IS} = 15\text{ mA}$ (Note 7)			0.35	$\Omega$
$\Delta R_{ON}$	$C_N$	On Resistance Matching( $C_N$ )	$V_{DD} = 1.5\text{ V}$ , $V_{IS} = 0\text{ V}$ , $I_{IS} = 15\text{ mA}$ (Note 7)			0.35	$\Omega$
$C_{ON}$	$A_N$ to $B_N$ , $A_N$ to $C_N$	On Capacitance	$f = 1\text{ MHz}$ , Switch On, Open Output		2.0		pF
$C_{OFF}$	$A_N$ to $B_N$ , $A_N$ to $C_N$	Off Capacitance	$f = 1\text{ MHz}$ , Switch Off		1.5		pF
$I_{ON}$	$A_N$ to $B_N$ , $A_N$ to $C_N$	On Leakage Current	$V_{DD} = 2\text{ V}$ , $V_{AN} = 0\text{ V}$ , $1.2\text{ V}$ , Switch On to $B_N/C_N$ , $B_N/C_N$ pins are unconnected	-1		+1	$\mu\text{A}$
$I_{OFF}$	$A_N$ to $B_N$ , $A_N$ to $C_N$	Off Leakage Current	$V_{DD} = 2\text{ V}$ , $V_{AN} = 0\text{ V}$ , $1.2\text{ V}$ , Switch Off to $B_N/C_N$ , $V_{BN}/V_{CN} = 1.2\text{ V}$ , $0\text{ V}$	-1		+1	$\mu\text{A}$

### LOGIC INPUT CHARACTERISTICS (SEL Pin)

$V_{IH}$	SEL	Input HIGH Voltage	(Note 7)	$0.65 \times V_{DD}$		$V_{DD}$	V
$V_{IL}$	SEL	Input LOW Voltage	(Note 7)	0		$0.35 \times V_{DD}$	V
$V_{IK}$	SEL	Clamp Diode Voltage	$V_{DD} = \text{Max}$ , $I_{SEL} = -18\text{ mA}$		-0.7	-1.2	V
$I_{IH}$	SEL	Input HIGH Current	$V_{DD} = \text{Max}$ , $V_{SEL} = V_{DD}$			$\pm 5$	$\mu\text{A}$
$I_{IL}$	SEL	Input LOW Current	$V_{DD} = \text{Max}$ , $V_{SEL} = \text{GND}$			$\pm 5$	$\mu\text{A}$

### SWITCHING CHARACTERISTICS

$t_{SELON}$	SEL, $A_N$ , $B_N/C_N$	Line Enable Time	SEL to $A_N$ , $B_N$ , $C_N$ $R_L = 50\ \Omega$ , $C_L = 20\ \text{pF}$		8.0		ns
$t_{SELOFF}$	SEL, $A_N$ , $B_N/C_N$	Line Disable Time	SEL to $A_N$ , $B_N$ , $C_N$ $R_L = 50\ \Omega$ , $C_L = 20\ \text{pF}$		5.0		ns
$t_{b-b}$	$A_N$ , $B_N/C_N$	Bit-to-bit skew	Within the same differential pair		5.0		ps
$t_{ch-ch}$	$A_N$ , $B_N$	Channel-to channel skew	Maximum skew between all channels		50		ps

5. For Max. or Min. conditions, use appropriate value specified under Electrical Characteristics for the applicable device type.

6. Typical values are at  $V_{DD} = 1.8\text{ V}$ ,  $T_A = 25^{\circ}\text{C}$  ambient and maximum loading.

7. Guaranteed by design and/or characterization.

# NCN3411

**DC ELECTRICAL CHARACTERISTICS OVER OPERATING RANGE** ( $T_A = -40^{\circ}\text{C}$  to  $+85^{\circ}\text{C}$ ,  $V_{DD} = 1.5\text{ V}$  to  $2.0\text{ V}$ ,  $\text{GND} = 0\text{V}$ )

Symbol	Pins	Parameters	Conditions (Note 5)	Min.	Typ (Note 6)	Max.	Units
--------	------	------------	---------------------	------	--------------	------	-------

**DYNAMIC ELECTRICAL CHARACTERISTICS OVER OPERATING RANGE**

BR	$A_N$ to $B_N$ , $A_N$ to $C_N$	Signal Bit Rate			8.0		Gbps
D <sub>IL</sub>	$A_N$ to $B_N$ , $A_N$ to $C_N$	Differential Insertion Loss	$f = 4\text{ GHz}$		-2.0		dB
			$f = 100\text{ MHz}$		-0.7		dB
D <sub>CTK</sub>	$A_N$ , $B_N$ , $C_N$	Differential Crosstalk	$f = 4\text{ GHz}$		-30		dB
			$f = 100\text{ MHz}$		-58		dB
D <sub>ISO</sub>	$A_N$ to $B_N$ , $A_N$ to $C_N$	Differential Off Isolation	$f = 4\text{ GHz}$		-20		dB
			$f = 100\text{ MHz}$		-58		dB
D <sub>RL</sub>	$A_N$ to $B_N$ , $A_N$ to $C_N$	Differential Return Loss	$f = 4\text{ GHz}$		-9.0		dB
			$f = 100\text{ MHz}$		-22		dB

- For Max. or Min. conditions, use appropriate value specified under Electrical Characteristics for the applicable device type.
- Typical values are at  $V_{DD} = 1.8\text{ V}$ ,  $T_A = 25^{\circ}\text{C}$  ambient and maximum loading.
- Guaranteed by design and/or characterization.

## TYPICAL OPERATING CHARACTERISTICS

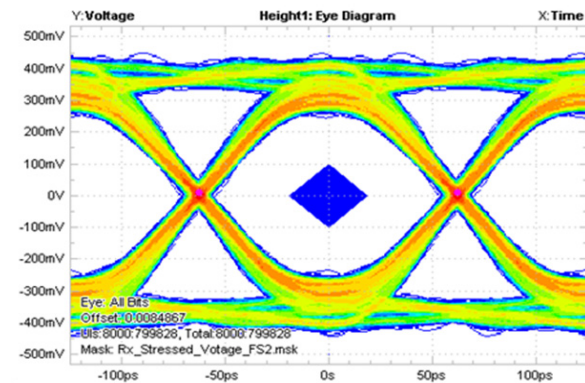

**Figure 4. Reference PCIe 3.0 Eye Diagram without Switch at 8 Gbps, 800 mV<sub>pp</sub> Differential Swing**

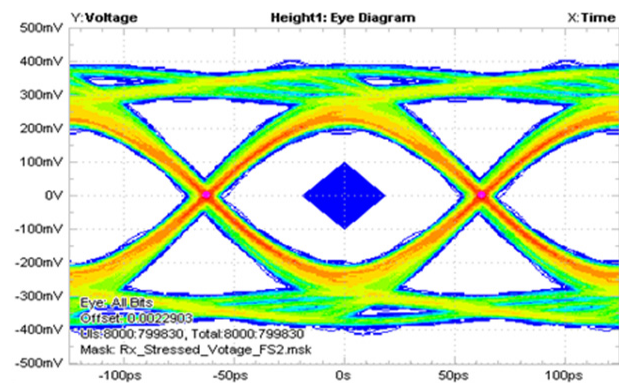

**Figure 5. PCIe 3.0 Eye Diagram through NCN3411 at 8 Gbps, 800 mV<sub>pp</sub> Differential Swing**

TYPICAL OPERATING CHARACTERISTICS

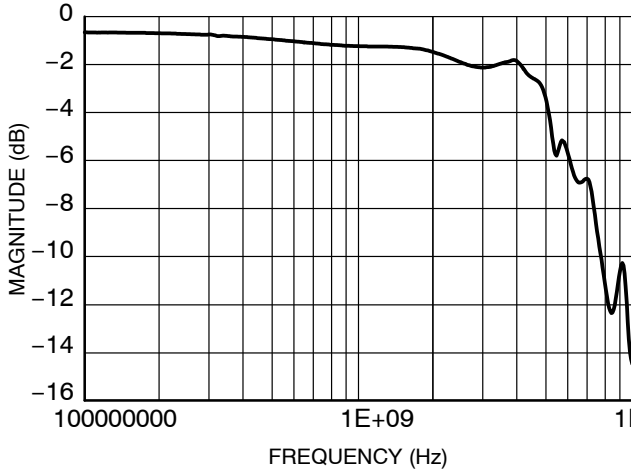

Figure 6. Differential Insertion Loss

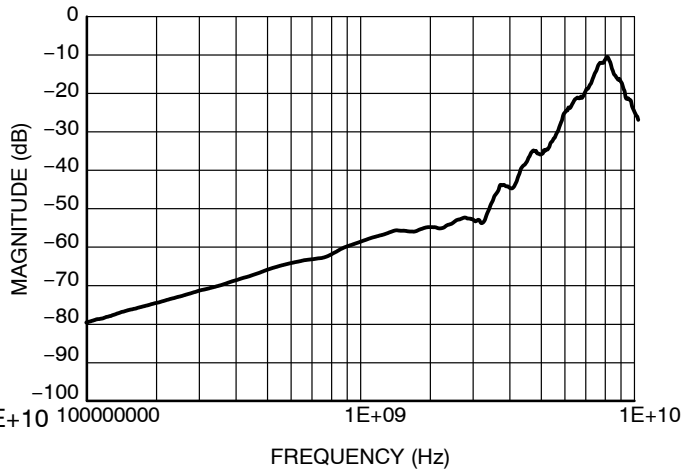

Figure 7. Differential Crosstalk



Figure 8. Differential Off Isolation

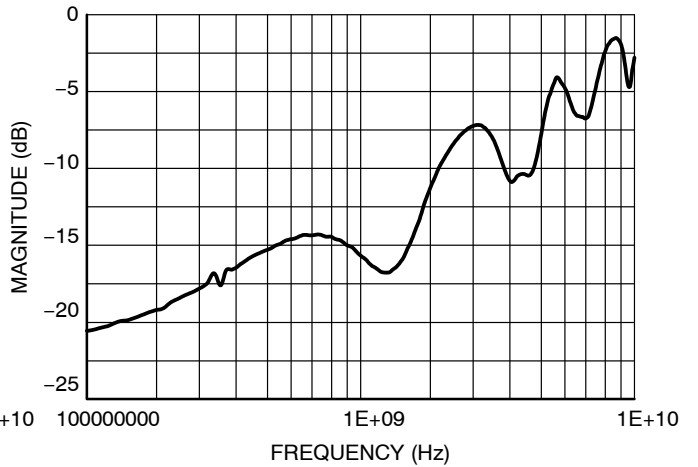

Figure 9. Differential Return Loss

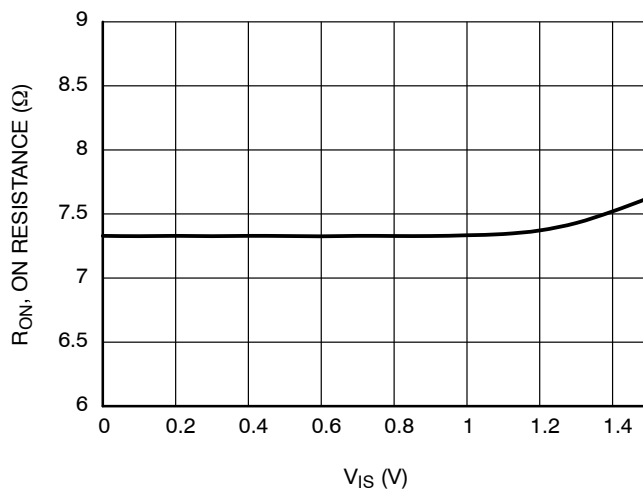

Figure 10. RON vs. VIS

PARAMETER MEASUREMENT INFORMATION

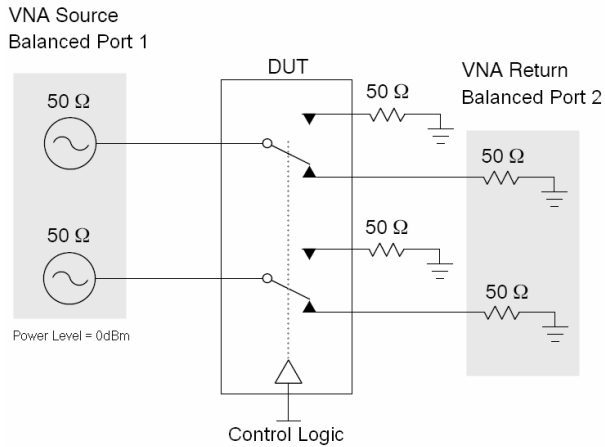

Figure 11. Differential Insertion Loss ( $S_{DD21}$ ) and Differential Return Loss ( $S_{DD11}$ )

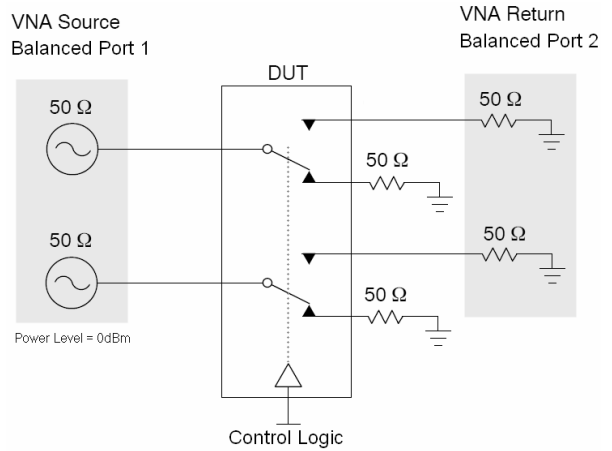

Figure 12. Differential Off Isolation ( $S_{DD21}$ )

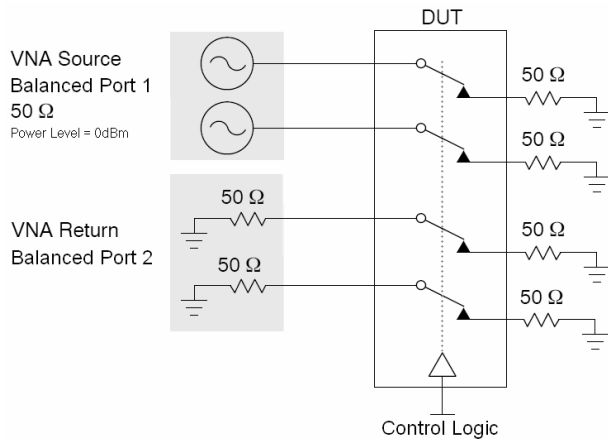

Figure 13. Differential Crosstalk ( $S_{DD21}$ )

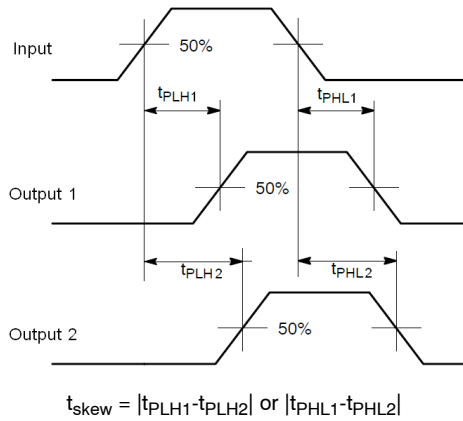

Figure 14. Bit-to-Bit and Channel-to-Channel Skew

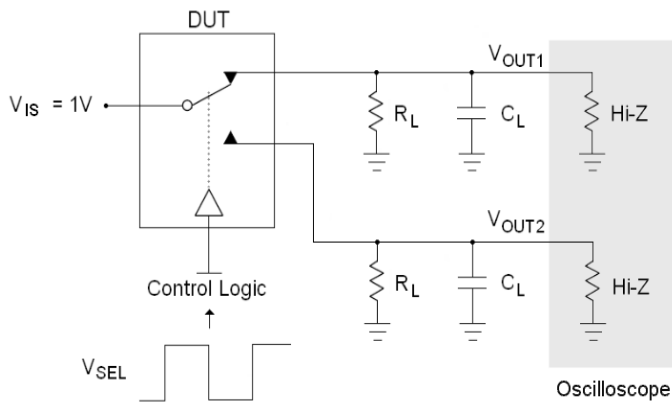

Figure 15.  $t_{ON}$  and  $t_{OFF}$

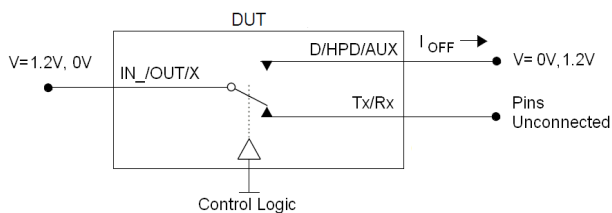
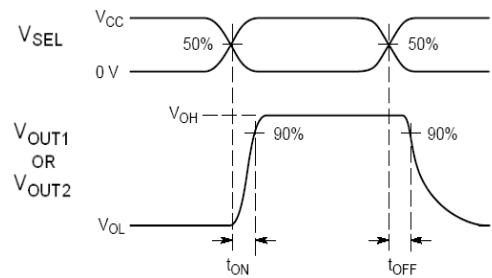

Figure 16. Off State Leakage

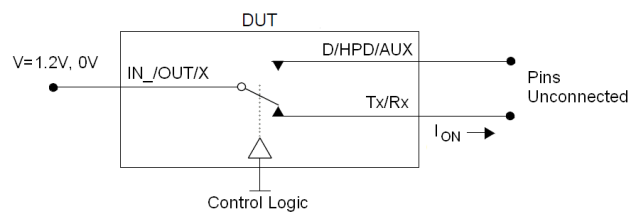
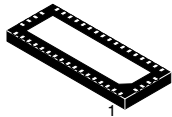

Figure 17. On State Leakage

# MECHANICAL CASE OUTLINE

## PACKAGE DIMENSIONS

ON Semiconductor®



SCALE 2:1

WQFN42 3.5x9, 0.5P  
CASE 510AP-01  
ISSUE O

DATE 15 FEB 2010

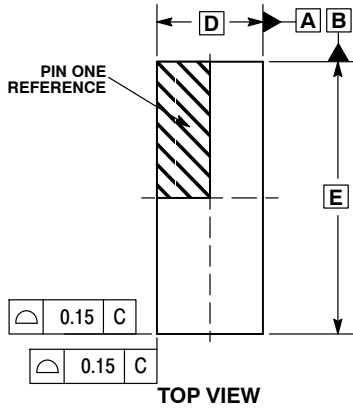

TOP VIEW

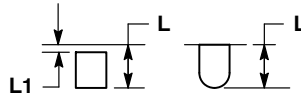

DETAIL A  
ALTERNATE TERMINAL  
CONSTRUCTIONS

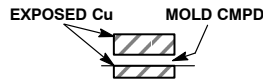

DETAIL B  
ALTERNATE  
CONSTRUCTION

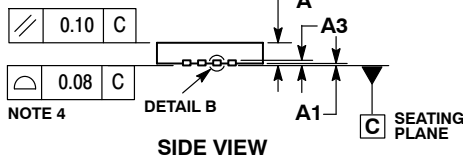

SIDE VIEW

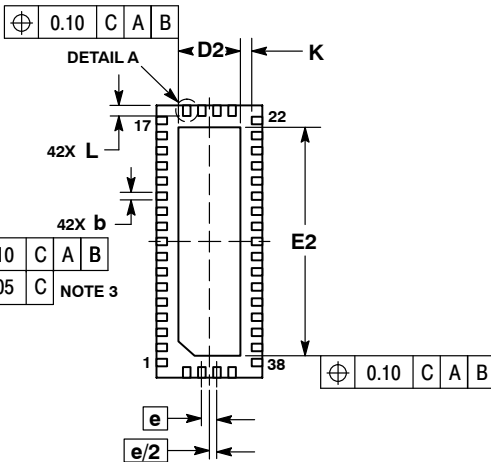

BOTTOM VIEW

NOTES:

1. DIMENSIONING AND TOLERANCING PER ASME Y14.5M, 1994.
2. CONTROLLING DIMENSION: MILLIMETERS.
3. DIMENSION b APPLIES TO PLATED TERMINAL AND IS MEASURED BETWEEN 0.15 AND 0.30 MM FROM TERMINAL TIP.
4. COPLANARITY APPLIES TO THE EXPOSED PAD AS WELL AS THE TERMINALS.

DIM	MILLIMETERS	
	MIN	MAX
A	0.70	0.80
A1	0.00	0.05
A3	0.20 REF	
b	0.20	0.30
D	3.50 BSC	
D2	1.95	2.15
E	9.00 BSC	
E2	7.45	7.65
e	0.50 BSC	
K	0.20	---
L	0.30	0.50
L1	0.00	0.15

GENERIC MARKING DIAGRAM\*

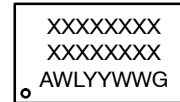

- XXXXX = Specific Device Code
- A = Assembly Location
- WL = Wafer Lot
- YY = Year
- WW = Work Week
- G = Pb-Free Package

\*This information is generic. Please refer to device data sheet for actual part marking. Pb-Free indicator, "G", may or not be present.

RECOMMENDED MOUNTING FOOTPRINT

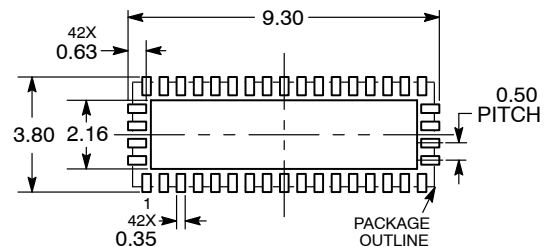

DIMENSIONS: MILLIMETERS

DOCUMENT NUMBER:	98AON48316E	Electronic versions are uncontrolled except when accessed directly from the Document Repository. Printed versions are uncontrolled except when stamped "CONTROLLED COPY" in red.
DESCRIPTION:	WQFN42 3.5X9, 0.5P	PAGE 1 OF 1

ON Semiconductor and are trademarks of Semiconductor Components Industries, LLC dba ON Semiconductor or its subsidiaries in the United States and/or other countries. ON Semiconductor reserves the right to make changes without further notice to any products herein. ON Semiconductor makes no warranty, representation or guarantee regarding the suitability of its products for any particular purpose, nor does ON Semiconductor assume any liability arising out of the application or use of any product or circuit, and specifically disclaims any and all liability, including without limitation special, consequential or incidental damages. ON Semiconductor does not convey any license under its patent rights nor the rights of others.

**onsemi**, **Onsemi**, and other names, marks, and brands are registered and/or common law trademarks of Semiconductor Components Industries, LLC dba "**onsemi**" or its affiliates and/or subsidiaries in the United States and/or other countries. **onsemi** owns the rights to a number of patents, trademarks, copyrights, trade secrets, and other intellectual property. A listing of **onsemi**'s product/patent coverage may be accessed at [www.onsemi.com/site/pdf/Patent-Marking.pdf](http://www.onsemi.com/site/pdf/Patent-Marking.pdf). **onsemi** reserves the right to make changes at any time to any products or information herein, without notice. The information herein is provided "as-is" and **onsemi** makes no warranty, representation or guarantee regarding the accuracy of the information, product features, availability, functionality, or suitability of its products for any particular purpose, nor does **onsemi** assume any liability arising out of the application or use of any product or circuit, and specifically disclaims any and all liability, including without limitation special, consequential or incidental damages. Buyer is responsible for its products and applications using **onsemi** products, including compliance with all laws, regulations and safety requirements or standards, regardless of any support or applications information provided by **onsemi**. "Typical" parameters which may be provided in **onsemi** data sheets and/or specifications can and do vary in different applications and actual performance may vary over time. All operating parameters, including "Typicals" must be validated for each customer application by customer's technical experts. **onsemi** does not convey any license under any of its intellectual property rights nor the rights of others. **onsemi** products are not designed, intended, or authorized for use as a critical component in life support systems or any FDA Class 3 medical devices or medical devices with a same or similar classification in a foreign jurisdiction or any devices intended for implantation in the human body. Should Buyer purchase or use **onsemi** products for any such unintended or unauthorized application, Buyer shall indemnify and hold **onsemi** and its officers, employees, subsidiaries, affiliates, and distributors harmless against all claims, costs, damages, and expenses, and reasonable attorney fees arising out of, directly or indirectly, any claim of personal injury or death associated with such unintended or unauthorized use, even if such claim alleges that **onsemi** was negligent regarding the design or manufacture of the part. **onsemi** is an Equal Opportunity/Affirmative Action Employer. This literature is subject to all applicable copyright laws and is not for resale in any manner.

## ADDITIONAL INFORMATION

### TECHNICAL PUBLICATIONS:

Technical Library: [www.onsemi.com/design/resources/technical-documentation](http://www.onsemi.com/design/resources/technical-documentation)  
onsemi Website: [www.onsemi.com](http://www.onsemi.com)

### ONLINE SUPPORT: [www.onsemi.com/support](http://www.onsemi.com/support)

For additional information, please contact your local Sales Representative at [www.onsemi.com/support/sales](http://www.onsemi.com/support/sales)

## Looking for pricing, stock, or lifecycle information?

Click below to explore more details on WIN SOURCE:

- ⊖ [View NCN3411MTTWG on WIN SOURCE](#)
- ⊖ [ON Semiconductor Information](#)

## Optimize Your Supply Chain with WIN SOURCE Solutions

- ✓ Global Sourcing Solution
- ✓ Obsolete Management
- ✓ Cost Control Management
- ✓ Shortage Management
- ✓ Alternative Solution
- ✓ Excess Inventory Management