



**THE DATASHEET OF
CRG0603F15K**



Type CRG Series

Key Features

Thick Film Resistors with high power to size ratio, ideally suited to industrial and general purpose use

Value range from 1Ω to 10MΩ

Eight package sizes

Terminal finish matte Sn over Ni

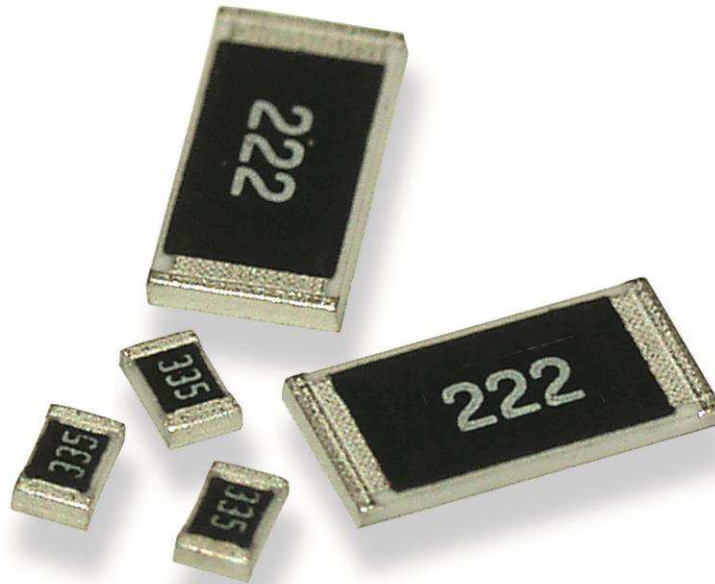

The resistive element is screen printed and fired, and a passivation layer added. Each resistor is trimmed to tolerance by laser. The pre-scribed tile is then broke into strips, the end plating fired on, and the strips broken into individual components. Final termination finish is electroplated matte Sn over a Ni barrier layer.

Electrical Characteristics

| Type | 0201 | 0402 | 0603 | 0805 | 1206 | 1210 | 2010 | 2512 |
|-----------------------------------|---------------|--------|------|-------|------|------|-------|------|
| Power rating (W) | 0.05 | 0.0625 | 0.1 | 0.125 | 0.25 | 0.5 | 0.75W | 1W |
| Resistance range (Ω) | Min | 1R0 | 1R0 | 1R0 | 1R0 | 1R0 | 1R0 | 1R0 |
| | Max | 10M | 10M | 10M | 10M | 10M | 10M | 10M |
| Tolerance (%) | 1 | 1 | 1 | 1 | 1 | 1 | 1 | 1 |
| Code Letter | F | F | F | F | F | F | F | F |
| Max Working Voltage | 25V | 50V | 75V | 150V | 200V | 200V | 200V | 200V |
| Max Overload Voltage | 50V | 100V | 150V | 300V | 400V | 500V | 500V | 500V |
| Dielectric Strength (V) | - | 100V | 300V | 500V | 500V | 500V | 500V | 500V |
| Rated current (Jumper) (A) | 0.5A | 1A | 1A | 2A | 2A | 2A | 2A | 2A |
| Max Overload Current (A) (Jumper) | 1A | 2A | 2A | 5A | 10A | 10A | 10A | 10A |
| Temperature Range | -55°C ~ 155°C | | | | | | | |

Power rating:

Resistors shall have a power rating based on continuous load operation at an ambient temperature of 70 °C . For temperature in excess of 70 °C , The load shall be derate as shown below

Derating Chart

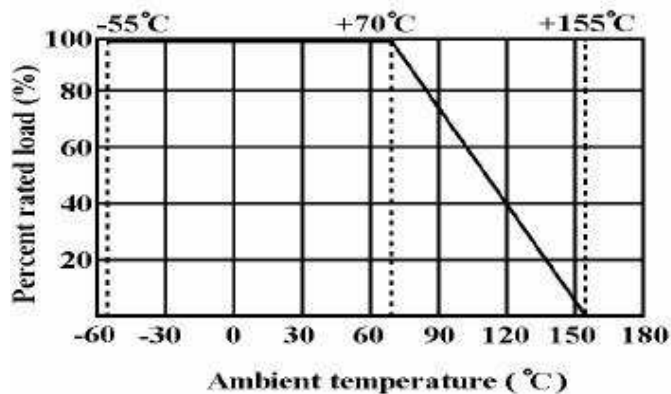

Construction

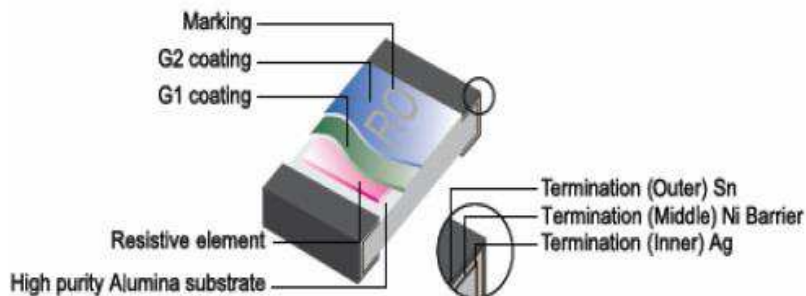

Dimensions:

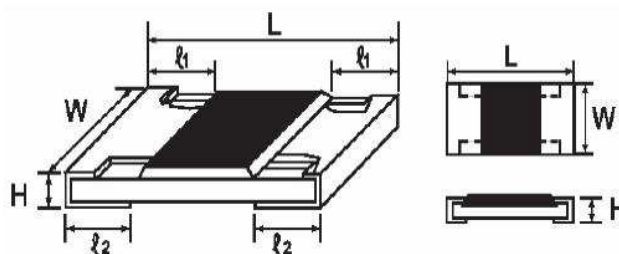

| Type | Dimensions (mm) | | | | |
|------|-----------------|--------------------|-----------|-----------|-----------|
| | L | W | H | l 1 | l 2 |
| 0201 | 0.60±0.03 | 0.30±0.03 | 0.23±0.03 | 0.10±0.05 | 0.15±0.05 |
| 0402 | 1.00±0.10 | 0.50±0.05 | 0.35±0.05 | 0.20±0.10 | 0.25±0.10 |
| 0603 | 1.60±0.10 | 0.80+0.15 -0.10 | 0.45±0.10 | 0.30±0.20 | 0.30±0.20 |
| 0805 | 2.00±0.15 | 1.25+0.15 -0.10 | 0.55±0.10 | 0.40±0.20 | 0.40±0.20 |
| 1206 | 3.10±0.15 | 1.55+0.15 -0.10 | 0.55±0.10 | 0.45±0.20 | 0.45±0.20 |
| 1210 | 3.10±0.10 | 2.60±0.15 | 0.55±0.10 | 0.50±0.25 | 0.50±0.20 |
| 2010 | 5.00±0.10 | 2.50±0.15 | 0.55±0.10 | 0.60±0.25 | 0.50±0.20 |
| 2512 | 6.35±0.10 | 3.20±0.15 | 0.55±0.10 | 0.60±0.25 | 0.50±0.20 |

Performance Specification:

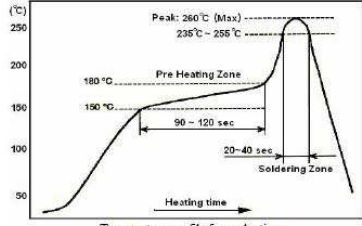
| Characteristic | Specification | Test Methods (JIS C 5201-1) |
|---|--|---|
| *Insulation Resistance | 1,000MΩ Min. | Apply 500V DC between protective coating and termination for 1 min, then measure (Sub-clause 4.6) |
| *Dielectric Withstanding Voltage | No evidence of flashover mechanical damage, arcing or insulation break down | Apply 100V(0402) 300V(0603) & 500V (0805,1206,1210,2010,2512) AC between protective coating and termination for 1 minute (Sub-clause 4.7) |
| Temperature Coefficient of Resistance (TCR) | 1Ω-10Ω : ± 400 PPM/°C 10.1Ω-100Ω : ± 200 PPM/°C 101Ω~10MΩ : ± 100 PPM/°C For 0201: >100Ω : ± 200 PPM/°C | Natural resistance change per temp. degree centigrade. $\frac{R_2 - R_1}{R_1(t_2 - t_1)} \times 10^6 \text{ (PPM/°C)}$ R1: Resistance value at room temperature (t1) R2: Resistance value at room temp. plus 100 °C (t2) (Sub-clause 4.8) |
| Short Term Overload | Resistance change rate is: ± 5% (2.0% + 0.1Ω) Max. ± 1% (1.0% + 0.1Ω) Max. | Permanent resistance change after the application of a potential of 2.5 times RCWV for 5 seconds (Sub-clause 4.13) |
| *Solderability | 95 % coverage Min. | Test temperature of solder : 245 ±3°C Dipping time solder : 2-3 seconds (Sub-clause 4.17) |
| Soldering Temp. Reference | Electrical characteristics shall be satisfied without distinct deformation in appearance. (95 % coverage Min.) | <p>Wave soldering condition: (2 cycles Max.) Pre-heat : 100 ~ 120 °C, 30 ± 5 sec. Suggestion solder temp.: 235 ~ 255 °C, 10 sec. (Max.) Peak temp.: 260 °C</p> <p>Reflow soldering condition: (2 cycles Max.) Pre-heat : 150 ~ 180 °C, 90 ~ 120 sec. Suggestion solder temp.: 235 ~ 255 °C, 20 ~ 40 sec. Peak temp.: 260 °C</p>  <p>Temperature profile for evaluation</p> <p>Hand soldering condition: The soldering iron tip temperature should be less than 300°C and maximum contract time should be 5 sec.</p> |
| Soldering Heat | Resistance change rate is: ±(1%+0.05Ω) Max. | Dip the resistor into a solder bath having a temperature of 260°C±3°C and hold it for 10±1 seconds. (Sub-clause 4.18) |

Performance Specification: (Continued)

| Characteristic | Specification | Test Methods (JIS C 5201-1) | | | | | | | | | | | | | | | |
|---|---|---|-----------------|-------------|------|---|-----------------|---------|---|-----------|------------|---|-----------------|---------|---|-----------|------------|
| Temperature Cycling | Resistance change rate is $\pm 5\%$ (1.0% + 0.05 Ω) Max. $\pm 1\%$ (0.5% + 0.05 Ω) Max. | Resistance change after continuous 5 cycles for duty cycle specified below : | | | | | | | | | | | | | | | |
| | | <table border="1"> <thead> <tr> <th>Step</th> <th>Temperature</th> <th>Time</th> </tr> </thead> <tbody> <tr> <td>1</td> <td>-55°C\pm3°C</td> <td>30 mins</td> </tr> <tr> <td>2</td> <td>Room Temp</td> <td>10~15 mins</td> </tr> <tr> <td>3</td> <td>155°C\pm2°C</td> <td>30 mins</td> </tr> <tr> <td>4</td> <td>Room Temp</td> <td>10~15 mins</td> </tr> </tbody> </table> | Step | Temperature | Time | 1 | -55°C \pm 3°C | 30 mins | 2 | Room Temp | 10~15 mins | 3 | 155°C \pm 2°C | 30 mins | 4 | Room Temp | 10~15 mins |
| | | Step | Temperature | Time | | | | | | | | | | | | | |
| | | 1 | -55°C \pm 3°C | 30 mins | | | | | | | | | | | | | |
| | | 2 | Room Temp | 10~15 mins | | | | | | | | | | | | | |
| 3 | 155°C \pm 2°C | 30 mins | | | | | | | | | | | | | | | |
| 4 | Room Temp | 10~15 mins | | | | | | | | | | | | | | | |
| (Sub-clause 4.19) | | | | | | | | | | | | | | | | | |
| Load Life in Humidity | Resistance change rate is $\pm 5\%$ (3.0% + 0.1 Ω) Max. $\pm 1\%$ (1.0% + 0.1 Ω) Max. | Resistance change after 1,000 hours (1.5 hours "on", 0.5 hour "off") at RCWV in a humidity chamber controlled at 40°C \pm 2°C and 90 to 95 % relative humidity (Sub-clause 4.24.2.1) | | | | | | | | | | | | | | | |
| Load Life | Resistance change rate is $\pm 5\%$ (3.0% + 0.1 Ω) Max. $\pm 1\%$ (1.0% + 0.1 Ω) Max. | Permanent resistance change after 1,000 hours operating at RCWV, with duty cycle of (1.5 hours "on", 0.5 hour "off") at 70°C \pm 2°C ambient (Sub-clause 4.25.1) | | | | | | | | | | | | | | | |
| Terminal Bending | Resistance change rate is \pm (1.0% + 0.05 Ω) Max. | Twist of Test Board : Y/X = 5/90 mm for 10 seconds (Sub-clause 4.33) | | | | | | | | | | | | | | | |
| The resistors of 0 Ω only can do the characteristic noted of * | | | | | | | | | | | | | | | | | |

Environment Related Substance

This product complies to EU RoHS directive, EU PAHs directive, EU PFOS directive and Halogen free. Ozone layer depleting substances are not used in our manufacturing process of this product.

This product is not manufactured using Chloro fluorocarbons (CFCs), Hydrochlorofluorocarbons (HCFCs), Hydrobromofluorocarbons (HBFCs) or other ozone depleting substances in any phase of the manufacturing process.

Storage Condition

The performance of these products, including the solderability, is guaranteed for a year from the date of arrival at your company, provided that they remain packed as they were when delivered and stored at a temperature of 25°C \pm 10°C and a relative humidity of 60%RH \pm 10%RH, chemical and dust free atmosphere

Even within the above guarantee periods, do not store these products in the following conditions otherwise, their electrical performance and/or solderability may be deteriorated, and the packaging materials (e.g. taping materials) may be deformed or deteriorated, resulting in mounting failures.

1. In salty air or in air with a high concentration of corrosive gas, such as Cl₂, H₂S, NH₃, SO₂, or NO₂
2. In direct sunlight

Marking

E24 series 0603 – 2512 3 Digits – first two digits denote significant figures of resistance and third digit denotes number of zeros thereafter. EG



Marking for E96 Series 0805 – 2512 4 digits – First three digits denote significant figures of resistance and fourth digit denotes number of zeros thereafter. EG.

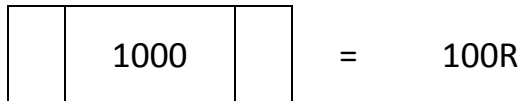

For ohmic values below 100R letter “R” denotes decimal point. EG

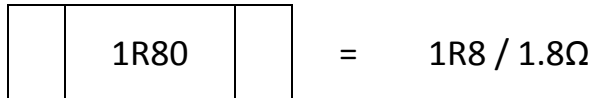

0201 and 0402 size chips are not marked

0603 E96 3 digit marking.

Resistance Code from table on next page, and Multiplier code from table below

Multiplier Code

| Code | A | B | C | D | E | F | G | H | X | Y | Z |
|-------|-----------------|-----------------|-----------------|-----------------|-----------------|-----------------|-----------------|-----------------|------------------|------------------|------------------|
| Mult. | 10 ⁰ | 10 ¹ | 10 ² | 10 ³ | 10 ⁴ | 10 ⁵ | 10 ⁶ | 10 ⁷ | 10 ⁻¹ | 10 ⁻² | 10 ⁻³ |

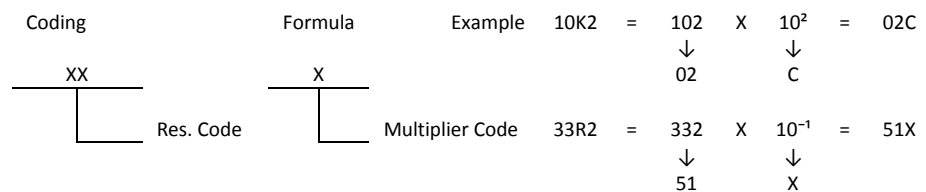

Resistance Code

| Value | Code | Value | Code | Value | Code | Value | Code | Value | Code |
|-------|------|-------|------|-------|------|-------|------|-------|------|
| 100 | 01 | 162 | 21 | 261 | 41 | 422 | 61 | 681 | 81 |
| 102 | 02 | 165 | 22 | 267 | 42 | 432 | 62 | 698 | 82 |
| 105 | 03 | 169 | 23 | 274 | 43 | 442 | 63 | 715 | 83 |
| 107 | 04 | 174 | 24 | 280 | 44 | 453 | 64 | 732 | 84 |
| 110 | 05 | 178 | 25 | 287 | 45 | 464 | 65 | 750 | 85 |
| 113 | 06 | 182 | 26 | 294 | 46 | 475 | 66 | 768 | 86 |
| 115 | 07 | 187 | 27 | 301 | 47 | 487 | 67 | 787 | 87 |
| 118 | 08 | 191 | 28 | 309 | 48 | 499 | 68 | 806 | 88 |
| 121 | 09 | 196 | 29 | 316 | 49 | 511 | 69 | 825 | 89 |
| 124 | 10 | 200 | 30 | 324 | 50 | 523 | 70 | 845 | 90 |
| 127 | 11 | 205 | 31 | 332 | 51 | 536 | 71 | 866 | 91 |
| 130 | 12 | 210 | 32 | 340 | 52 | 549 | 72 | 887 | 92 |
| 133 | 13 | 215 | 33 | 348 | 53 | 562 | 73 | 909 | 93 |
| 137 | 14 | 221 | 34 | 357 | 54 | 576 | 74 | 931 | 94 |
| 140 | 15 | 226 | 35 | 365 | 55 | 590 | 75 | 953 | 95 |
| 143 | 16 | 232 | 36 | 374 | 56 | 604 | 76 | 976 | 96 |
| 147 | 17 | 237 | 37 | 383 | 57 | 619 | 77 | | |
| 150 | 18 | 243 | 38 | 392 | 58 | 634 | 78 | | |
| 154 | 19 | 249 | 39 | 402 | 59 | 649 | 79 | | |
| 158 | 20 | 255 | 40 | 412 | 60 | 665 | 80 | | |

Label

Label shall be marked with the following item :

- A. Nominal Resistance and Resistance Tolerance
- B. Power Rating and Size
- C. Quantity and description
- D. Part No.
- E. Lot No.
- Ex.

| | | |
|--|---|-----------|
| RT008-04 |  | |
| 606150040052 | CHIP RESISTORS | r |
| Resistance: 100R Ω | | $\pm 1\%$ |
| Wattage: 0.25W | Size: 1206 | |
| Quantity: 5000 PCS | CRG 1206 1% 100R | |
| PART NO. 1623403-1 | RoHS 2011/65/EU | |
| LOT NO. | REF # | |
| Order Code (YYWW) | 1623 Rev. BA | |
|  | | |

Packing Specification:

Tape dimensions (mm)

A. Paper Taping

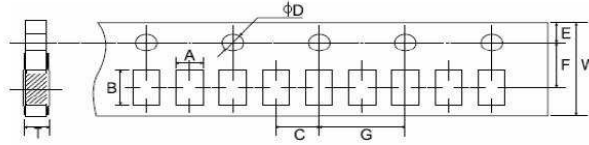

| Type | A±0.2 | B±0.2 | C±0.05 | ∅D+0.1 -0 | E±0.1 | F±0.05 | G±0.1 | W±0.2 | T±0.1 |
|------|---------------|---------------|--------|--------------|-------|--------|-------|-------|-------|
| 0201 | 0.40 ±0.05 | 0.70 ±0.05 | 2.0 | 1.5 | 1.75 | 3.5 | 4.0 | 8.0 | 0.42 |
| 0402 | 0.65 | 1.15 | 2.0 | 1.5 | 1.75 | 3.5 | 4.0 | 8.0 | 0.45 |

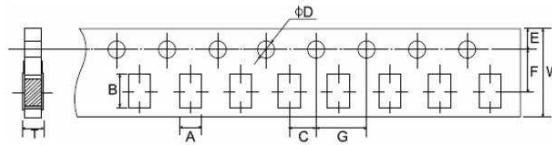

| Type | A±0.2 | B±0.2 | C±0.05 | ∅D+0.1 -0 | E±0.1 | F±0.05 | G±0.1 | W±0.2 | T±0.1 |
|------|-------|-------|--------|--------------|-------|--------|-------|-------|-------|
| 0603 | 1.10 | 1.90 | 2.0 | 1.5 | 1.75 | 3.5 | 4.0 | 8.0 | 0.67 |
| 0805 | 1.65 | 2.40 | 2.0 | 1.5 | 1.75 | 3.5 | 4.0 | 8.0 | 0.81 |
| 1206 | 2.00 | 3.60 | 2.0 | 1.5 | 1.75 | 3.5 | 4.0 | 8.0 | 0.81 |
| 1210 | 2.80 | 3.50 | 2.0 | 1.5 | 1.75 | 3.5 | 4.0 | 8.0 | 0.75 |

B. Embossed Taping

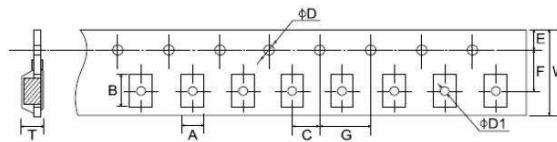

| Type | A ±0.2 | B ±0.2 | C ±0.05 | ∅D+0.1 -0 | ∅D1+0.1 -0 | E ±0.1 | F ±0.05 | G ±0.1 | W ±0.2 | T ±0.1 |
|------|-----------|-----------|------------|--------------|---------------|-----------|------------|-----------|-----------|-----------|
| 2010 | 2.90 | 5.60 | 2.0 | 1.5 | 1.5 | 1.75 | 5.5 | 4.0 | 12.0 | 1.0 |
| 2512 | 3.50 | 6.70 | 2.0 | 1.5 | 1.5 | 1.75 | 5.5 | 4.0 | 12.0 | 1.0 |

* Peeling Strength of Top Cover Tape

Test Condition: 0.1 to 0.7 N at a peel-off speed of 300 mm / min.

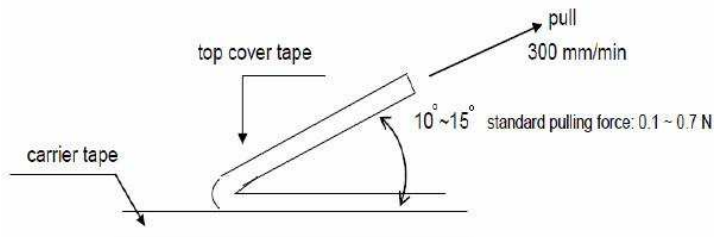

Reel Dimension (mm)

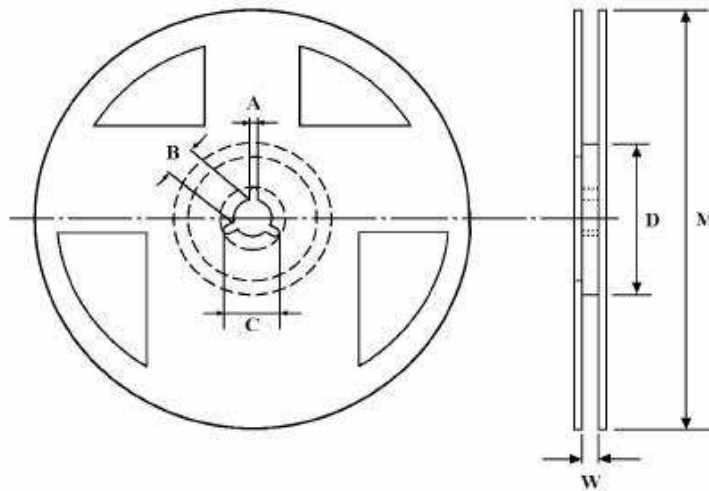

| Type | Taping | Reel Quantity | A ±0.5 | B ±0.5 | C ±0.5 | D ±1 | M ±1 | W ±1 |
|------|----------|---------------|--------|--------|--------|------|------|------|
| 0201 | Paper | 10,000 | 2 | 13 | 21 | 60 | 178 | 10 |
| 0402 | Paper | 10,000 | 2 | 13 | 21 | 60 | 178 | 10 |
| 0603 | Paper | 5,000 | 2 | 13 | 21 | 60 | 178 | 10 |
| 0805 | Paper | 5,000 | 2 | 13 | 21 | 60 | 178 | 10 |
| 1206 | Paper | 5,000 | 2 | 13 | 21 | 60 | 178 | 10 |
| 1210 | Paper | 5,000 | 2 | 13 | 21 | 60 | 178 | 10 |
| 2010 | Embossed | 4,000 | 2 | 13 | 21 | 60 | 178 | 13.8 |
| 2512 | Embossed | 4,000 | 2 | 13 | 21 | 60 | 178 | 13.8 |

How To Order

| CRG | 0603 | F | 10K | |
|--------------------------------|------|-----------|-----------------------|-------------------------|
| Common Part | Size | Tolerance | Resistance Value | |
| CRG - Thick Film Chip Resistor | 0201 | F - ±1% | 1 ohm (1Ω) 1R0 | |
| | 0402 | | 1K ohm (1000Ω) 1K0 | |
| | 0603 | | | |
| | 0805 | | | |
| | 1206 | | | 100K ohm (100000Ω) 100K |
| | 1210 | | | |
| | 2010 | | | |
| | 2512 | | 1M ohm (1000000Ω) 1M0 | |

Looking for pricing, stock, or lifecycle information?

Click below to explore more details on WIN SOURCE:

- ⊖ [View CRG0603F15K on WIN SOURCE](#)
- ⊖ [TE Connectivity Information](#)

Optimize Your Supply Chain with WIN SOURCE Solutions

- ✓ Global Sourcing Solution
- ✓ Obsolete Management
- ✓ Cost Control Management
- ✓ Shortage Management
- ✓ Alternative Solution
- ✓ Excess Inventory Management