



**THE DATASHEET OF
XQ17V16CC44M**



Features

- 16Mbit storage capacity
- Guaranteed operation over full military temperature range: -55°C to $+125^{\circ}\text{C}$
- One-time programmable (OTP) read-only memory designed to store configuration bitstreams of Xilinx FPGA devices
- Dual configuration modes
 - Serial slow/fast configuration (up to 20 Mb/s)
 - Parallel (up to 160 Mb/s at 20 MHz)
- Simple interface to Xilinx QPro FPGAs

- Cascadable for storing longer or multiple bitstreams
- Programmable reset polarity (active High or active Low) for compatibility with different FPGA solutions
- Low-power CMOS Floating Gate process
- 3.3V supply voltage
- Available in compact plastic VQ44 and ceramic CC44 packages
- Programming support by leading programmer manufacturers.
- Design support using the Xilinx Alliance and Foundation series software packages.
- Guaranteed 20 year life data retention

Description

Xilinx introduces the high-density QPro™ XQ17V16 series QML configuration PROM which provide an easy-to-use, cost-effective method for storing large Xilinx FPGA configuration bitstreams. The XQ17V16 is a 3.3V device with a storage capacity of 16 Mb and can operate in either a serial or byte wide mode. See [Figure 1](#) for a simplified block diagram of the XQ17V16 device architecture.

When the FPGA is in Master Serial mode, it generates a configuration clock that drives the PROM. A short access time after the rising clock edge, data appears on the PROM DATA output pin that is connected to the FPGA DIN pin. The FPGA generates the appropriate number of clock pulses to complete the configuration. Once configured, it disables the PROM. When the FPGA is in Slave Serial mode, the PROM and the FPGA must both be clocked by an incoming signal.

When the FPGA is in Master SelectMAP mode, it generates a configuration clock that drives the PROM and the FPGA. After the rising CCLK edge, data are available on the PROMs DATA (D0-D7) pins. The data will be clocked into the FPGA on the following rising edge of the CCLK. When the FPGA is in Slave SelectMAP mode, the PROM and the FPGA must both be clocked by an incoming signal. A free-running oscillator may be used to drive CCLK. See [Figure 2](#).

Multiple devices can be concatenated by using the $\overline{\text{CEO}}$ output to drive the $\overline{\text{CE}}$ input of the following device. The clock inputs and the DATA outputs of all PROMs in this chain are interconnected. All devices are compatible and can be cascaded with other members of the family.

For device programming, either the Xilinx Alliance or Foundation series development system compiles the FPGA design file into a standard Hex format, which is then transferred to most commercial PROM programmers.

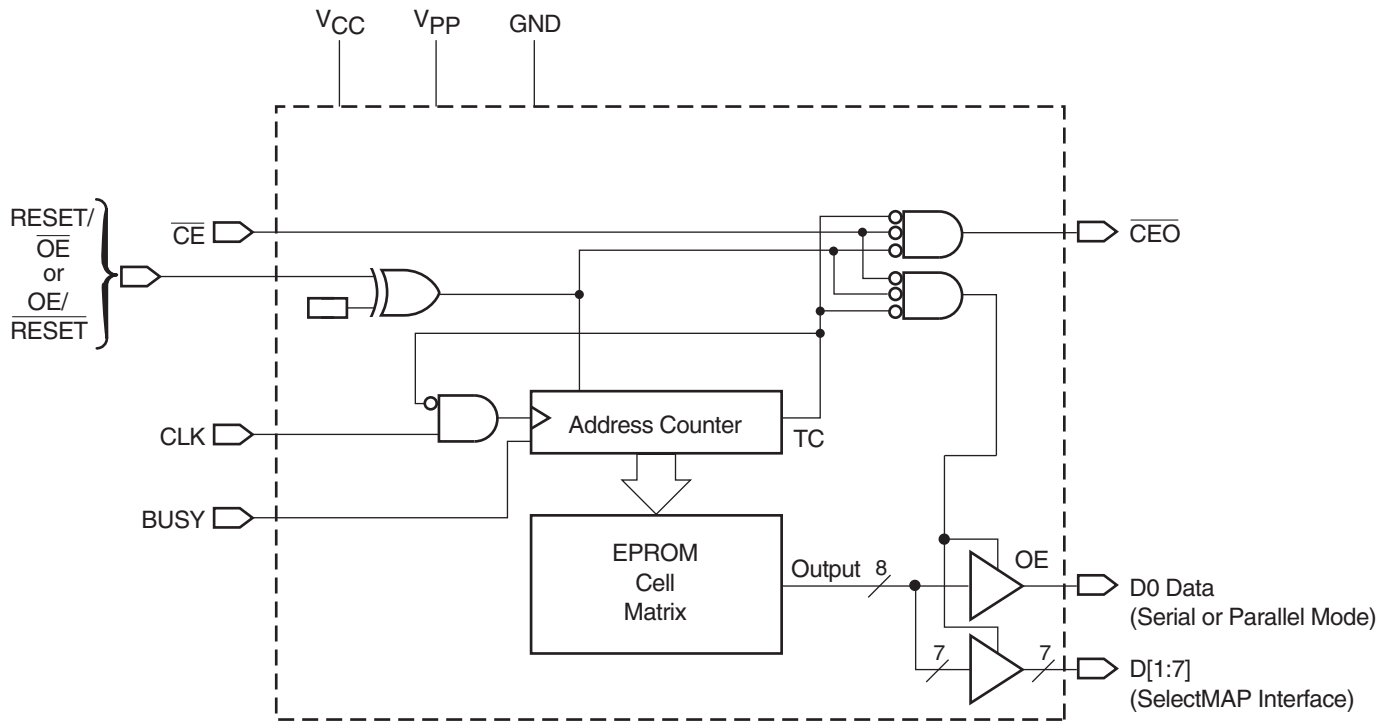

DS111_01_091414

Figure 1: Simplified Block Diagram for XQ17V16 (does not show programming circuit)

Pin Description

DATA[0:7]

Data output is in a high-impedance state when either \overline{CE} or \overline{OE} are inactive. During programming, the D0 pin is I/O. Note that \overline{OE} can be programmed to be either active High or active Low.

During device programming, the device must be programmed for use in either serial output mode or parallel output mode. For devices programmed to serial output mode, only the D0 pin is enabled for data output. In serial mode, the D[1-7] output pins remain in high impedance state. For devices programmed to parallel output mode, all D[0-7] output pins are enabled for byte-wide data output.

Per the programmed output mode, the array data bit or byte value corresponding to the internal address counter location is output on the D[0] or D[0-7] pins when CE is active, OE is active, and the internal address counter has not incremented beyond its terminal count (TC) value. Otherwise, all data pins are in a high impedance state when CE is inactive, OE is inactive, or the internal address counter has incremented beyond its terminal count (TC) value.

During programming, the D0 pin is I/O.

CLK

Each rising edge on the CLK input increments the internal address counter, if both \overline{CE} and \overline{OE} are active.

RESET/ \overline{OE}

When High, this input holds the address counter reset and puts the DATA output in a high-impedance state. The polarity of this input pin is programmable as either RESET/ \overline{OE} or OE/ \overline{RESET} . To avoid confusion, this document describes the pin as RESET/ \overline{OE} , although the opposite polarity is possible on all devices. When RESET is active, the address counter is held at "0", and puts the DATA output in a high-impedance state. The polarity of this input is programmable. The default is active High RESET, but the preferred option is active Low \overline{RESET} , because it can be connected to the FPGAs \overline{INIT} pin and a pullup resistor.

The polarity of RESET/ \overline{OE} is controlled in the programmer interface. This input pin is easily inverted using the Xilinx HW-130 Programmer. Third-party programmers have different methods to invert this pin.

\overline{CE}

When High, this pin holds the internal address counter in reset, puts the DATA output in a high-impedance state, and forces the device into low- I_{CC} standby mode.

\overline{CEO}

Chip Enable output, to be connected to the \overline{CE} input of the next PROM in the daisy chain. This output is Low when the \overline{CE} and \overline{OE} inputs are both active AND the internal address counter has been incremented beyond its Terminal Count (TC) value. In other words: when the PROM has been read, \overline{CEO} will follow \overline{CE} as long as \overline{OE} is active. When \overline{OE} goes inactive, \overline{CEO} stays High until the PROM is reset. Note that \overline{OE} can be programmed to be either active High or active Low.

BUSY (XQ17V16 only)

If BUSY pin is floating, the user must program the BUSY bit which will cause BUSY pin to be internally tied to a pull-down resistor. When asserted High, output data are held and when BUSY pin goes Low, data output will resume.

V_{PP}

Programming voltage. No overshoot above the specified max voltage is permitted on this pin. For normal read operation, this pin must be connected to V_{CC} . Failure to do so may lead to unpredictable, temperature-dependent operation and severe problems in circuit debugging. Do not leave V_{PP} floating!

V_{CC} and GND

Positive supply and ground pins.

PROM Pinouts

(Pins not listed are “no connect”)

Pin Name	44-pin VQFP	44-pin CLCC
BUSY	24	30
D0	40	2
D1	29	35
D2	42	4
D3	27	33
D4	9	15
D5	25	31
D6	14	20
D7	19	25
CLK	43	5
RESET/ \overline{OE} (OE/RESET)	13	19
\overline{CE}	15	21
GND	6, 18, 28, 37, 41	3, 12, 24, 34, 43
\overline{CEO}	21	27
V_{PP}	35	41
V_{CC}	8, 16, 17, 26, 36, 38	14, 22, 23, 32, 42, 44

Capacity

Device	Configuration Bits
XQ17V16	16,777,216

Xilinx FPGAs and Compatible PROMs

Device	Configuration Bits	XQ17V16(s)
XQ2V1000	4,082,656	1
XQ2V3000	10,494,432	1
XQ2V6000	21,849,568	2
XQV600E	3,961,632	1
XQV1000E	6,587,520	1
XQV2000E	10,159,648	1
XQV100	781,216	XQ1701L ⁽¹⁾
XQV300	1,751,808	1
XQV600	3,607,968	1
XQV1000	6,127,744	1

Notes:

1. See XQ1701L Series (DS062)

Controlling PROMs

Connecting the FPGA device with the PROM.

- For serial mode, the D[0] output(s) of the PROM(s) drives the D_{IN} input of the lead FPGA device.
- For parallel mode, the D[0-7] outputs of the PROM(s) drive the D[0-7] data inputs of the FPGA(s).
- The CCLK pin of the FPGA(s) is connected to the CLK input of the PROM(s) and an optional external clock source. When all FPGAs are in a slave configuration mode, the external clock source connection is required. When a master FPGA configuration mode is used, only one FPGA is in a master configuration mode, the master mode FPGA drives the clock signal, and remaining FPGA(s) are in a slave configuration mode.
- The \overline{CEO} output of a PROM drives the \overline{CE} input of the next PROM in a daisy chain (if any).
- The \overline{RESET}/OE input of all PROMs is best driven by the \overline{INIT} output of the FPGA(s). This connection assures that the PROM address counter is reset before the start of any (re)configuration, even when a reconfiguration is initiated by a V_{CC} glitch.
- The PROM \overline{CE} input is best connected to the DONE pin of the FPGAs and a pullup resistor. \overline{CE} can also be permanently tied Low, but this keeps the DATA output active and causes an unnecessary supply current of 15 mA maximum.
- SelectMAP mode is similar to Slave Serial mode. The DATA is clocked out of the PROM one byte per CCLK instead of one bit per CCLK cycle. See FPGA data sheets for special configuration requirements.

FPGA Master Serial Mode Summary

The I/O and logic functions of the Configurable Logic Block (CLB) and their associated interconnections are established by a configuration program. The program is loaded either automatically upon power up, or on command, depending on the state of the three FPGA mode pins. In Master Serial mode, the FPGA automatically loads the configuration program from an external memory. The Xilinx PROMs have been designed for compatibility with the Master Serial mode.

Upon power-up or reconfiguration, an FPGA enters the Master Serial mode whenever all three of the FPGA mode-select pins are Low ($M0=0$, $M1=0$, $M2=0$). Data is read from the PROM sequentially on a single data line. Synchronization is provided by the rising edge of the temporary signal CCLK, which is generated during configuration.

Master Serial Mode provides a simple configuration interface. Only a serial data line, two control lines, and a clock line are required to configure an FPGA. Data from the PROM is read sequentially, accessed via the internal address and bit counters which are incremented on every valid rising edge of CCLK.

If the user-programmable, dual-function DIN pin on the FPGA is used only for configuration, it must still be held at a defined level during normal operation. The Xilinx FPGA families take care of this automatically with an on-chip default pull-up/down resistor or keeper circuit.

Cascading Configuration PROMs

For multiple FPGAs configured as a daisy-chain, or for future FPGAs requiring larger configuration memories, cascaded PROMs provide additional memory. After the last bit from the first PROM is read, the next clock signal to the PROM asserts its \overline{CEO} output Low and disables its DATA line. The second PROM recognizes the Low level on its \overline{CE} input and enables its DATA output. See [Figure 2](#).

After configuration is complete, the address counters of all cascaded PROMs are reset if the FPGA $\overline{PROGRAM}$ pin goes Low, assuming the PROM reset polarity option has been inverted.

Programming

The devices can be programmed on programmers supplied by Xilinx or qualified third-party vendors. The user must ensure that the appropriate programming algorithm and the latest version of the programmer software are used. The wrong choice can permanently damage the device.

The OE/RESET input polarity is set through the programmer. For compatibility with Xilinx FPGAs, the OE/RESET polarity must be programmed with RESET active-Low. In addition, the serial or parallel output mode is set via the programmer, and the setting must match the FPGA configuration mode.

Table 1: Truth Table for XQ17V16 Control Inputs

Control Inputs		Internal Address	Outputs		
RESET ⁽¹⁾	CE		DATA	CEO	I _{CC}
Inactive	Low	If address \leq TC ⁽²⁾ : increment If address $>$ TC ⁽²⁾ : don't change	Active High-Z	High Low	Active Reduced
Active	Low	Held reset	High-Z	High	Active
Inactive	High	Not changing	High-Z	High	Standby
Active	High	Held reset	High-Z	High	Standby

Notes:

1. The XQ17V16 RESET input has programmable polarity.
2. TC = Terminal Count = highest address value. TC + 1 = address 0.

Absolute Maximum Ratings

Symbol	Description	Conditions	Units	
V _{CC}	Supply voltage relative to GND	-0.5 to +7.0	V	
V _{PP}	Supply voltage relative to GND	-0.5 to +12.5	V	
V _{IN}	Input voltage relative to GND	-0.5 to V _{CC} +0.5	V	
V _{TS}	Voltage applied to High-Z output	-0.5 to V _{CC} +0.5	V	
T _{STG}	Storage temperature (ambient)	-65 to +150	°C	
T _{SOL}	Maximum soldering temperature (10s @ 1/16 in.)	+260	°C	
T _J	Junction temperature	Ceramic	+150	°C
		Plastic	+125	°C

Notes:

1. Stresses beyond those listed under Absolute Maximum Ratings may cause permanent damage to the device. These are stress ratings only, and functional operation of the device at these or any other conditions beyond those listed under Operating Conditions is not implied. Exposure to Absolute Maximum Ratings conditions for extended periods of time may affect device reliability.

Operating Conditions (3.3V Supply)

Symbol	Description		Min	Max	Units
$V_{CC}^{(1)}$	Supply voltage relative to GND ($T_C = -55^\circ\text{C}$ to $+125^\circ\text{C}$)	Ceramic	3.0	3.6	V
	Supply voltage relative to GND ($T_J = -55^\circ\text{C}$ to $+125^\circ\text{C}$)	Plastic	3.0	3.6	V
$T_{VCC}^{(2)}$	V_{CC} rise time from 0V to nominal voltage		1.0	50	ms

Notes:

1. During normal read operation V_{PP} **must** be connected to V_{CC} .
2. At power up, the device requires the V_{CC} power supply to monotonically rise from 0V to nominal voltage within the specified V_{CC} rise time. If the power supply cannot meet this requirement, then the device may not power-on-reset properly.

DC Characteristics Over Operating Condition

Symbol	Description	Min	Max	Units
V_{IH}	High-level input voltage	2	V_{CC}	V
V_{IL}	Low-level input voltage	0	0.8	V
V_{OH}	High-level output voltage ($I_{OH} = -3$ mA)	2.4	–	V
V_{OL}	Low-level output voltage ($I_{OL} = +3$ mA)	–	0.4	V
I_{CCA}	Supply current, active mode (at maximum frequency)	–	100	mA
I_{CCS}	Supply current, standby mode	–	1	mA
I_L	Input or output leakage current	–10	10	μA
C_{IN}	Input capacitance ($V_{IN} = \text{GND}$, $f = 1.0$ MHz)	–	15	pF
C_{OUT}	Output capacitance ($V_{IN} = \text{GND}$, $f = 1.0$ MHz)	–	15	pF

AC Characteristics Over Operating Conditions for XQ17V16

Symbol	Description	Min	Max	Units
T_{OE}	\overline{OE} to data delay	–	15	ns
T_{CE}	\overline{CE} to data delay	–	20	ns
T_{CAC}	CLK to data delay ⁽²⁾	–	20	ns
T_{DF}	\overline{CE} or \overline{OE} to data float delay ^(3,4)	–	35	ns
T_{OH}	Data hold from \overline{CE} , \overline{OE} , or CLK ⁽⁴⁾	0	–	ns
T_{CYC}	Clock periods	50	–	ns
T_{LC}	CLK Low time ⁽⁴⁾	25	–	ns
T_{HC}	CLK High time ⁽⁴⁾	25	–	ns
T_{SCE}	\overline{CE} setup time to CLK (to guarantee proper counting)	25	–	ns
T_{HCE}	\overline{CE} hold time to CLK (to guarantee proper counting)	0	–	ns
T_{CEH}	\overline{CE} High time (guarantees counters are reset)	20	–	ns
T_{HOE}	\overline{OE} High time (guarantees counters are reset)	25	–	ns
T_{SBUSY}	BUSY setup time	5	–	ns
T_{HBUSY}	BUSY hold time	5	–	ns

Notes:

1. AC test load = 50 pF.
2. When BUSY = 0.
3. Float delays are measured with 5 pF AC loads. Transition is measured at ± 200 mV from steady state active levels.
4. Guaranteed by design, not tested.
5. All AC parameters are measured with $V_{IL} = 0.0V$ and $V_{IH} = 3.0V$.
6. If T_{CEH} is High < 2 μs , then $T_{CE} = 2 \mu s$.
7. If T_{HOE} is High < 2 μs , then $T_{OE} = 2 \mu s$.

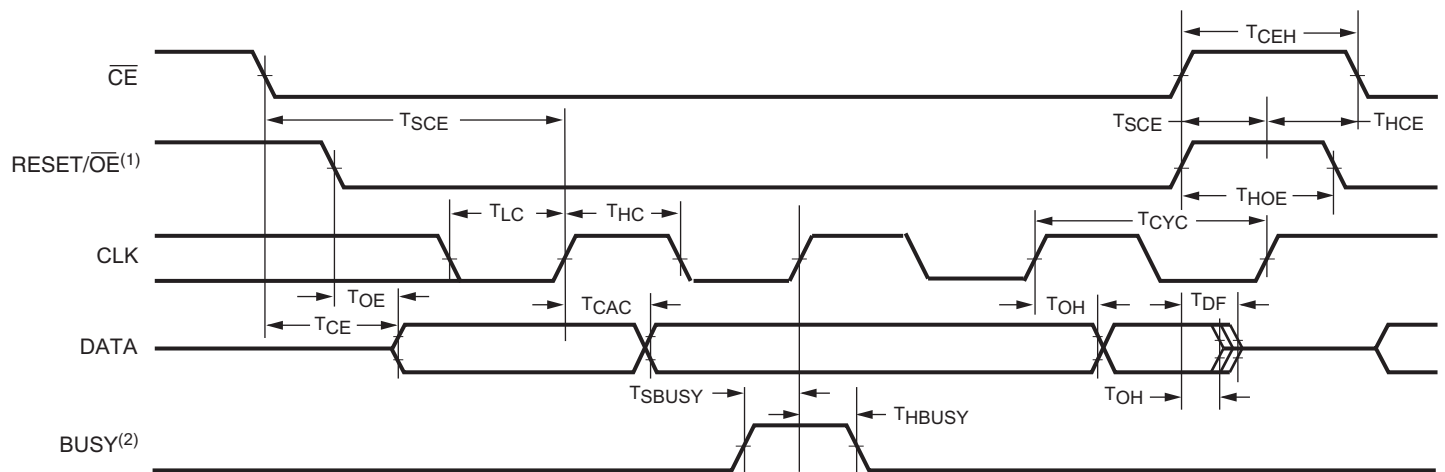

DS111_05_091414

Figure 3: Timing Diagram for AC Characteristics Over Operating Conditions

Notes:

1. The XQ17V16 RESET/OE input polarity is programmable. The RESET/OE input is shown in the timing diagram with active-High RESET polarity. Timing specifications are identical for both polarity settings.
2. If BUSY is inactive (Low) during a rising CLK edge, then new DATA appears at time T_{CAC} after the rising CLK edge. If BUSY is active (High) during a rising CLK edge, then there is no corresponding change to DATA.

AC Characteristics Over Operating Conditions When Cascading

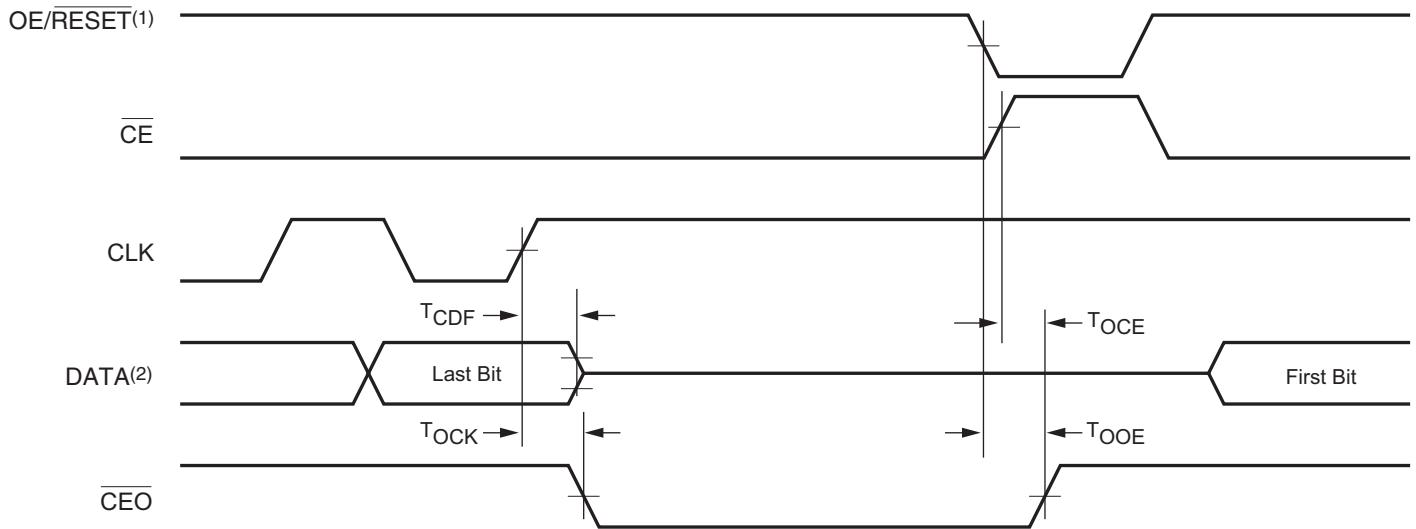

DS111_04_091414

Figure 4: Timing Diagram for AC Characteristics Over Operating Conditions When Cascading

Notes:

1. The XQ17V16 RESET/OE input polarity is programmable. The RESET/OE input is shown in the timing diagram with active-Low RESET polarity. Timing specifications are identical for both polarity settings.
2. The diagram shows timing of the first bit and last bit for one PROM with respect to signals involved in a cascaded situation. The diagram does not show timing of data as one PROM transfers control to the next PROM. The shown timing information must be applied appropriately to each PROM in a cascaded situation to understand the timing of data during the transfer of control from one PROM to the next.

Symbol	Description	Min	Max	Units
T _{CDF}	CLK to data float delay ^(2,3)	–	50	ns
T _{OCK}	CLK to CEO delay ⁽³⁾	–	30	ns
T _{OCE}	CE to CEO delay ⁽³⁾	–	35	ns
T _{OOE}	RESET/OE to CEO delay ⁽³⁾	–	30	ns

Notes:

1. AC test load = 50 pF
2. Float delays are measured with 5 pF AC loads. Transition is measured at ±200 mV from steady state active levels.
3. Guaranteed by design, not tested.
4. All AC parameters are measured with V_{IL} = 0.0V and V_{IH} = 3.0V.

Ordering Information

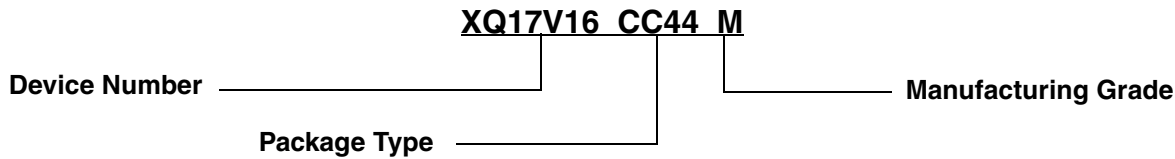

Device Ordering Options

Device Type	Package		Grade		
XQ17V16	CC44	44-pin Ceramic Chip Carrier Package	M	Military Ceramic	$T_C = -55^{\circ}\text{C to } +125^{\circ}\text{C}$
	VQ44	44-pin Plastic Thin Quad Flat Package	N	Military Plastic	$T_J = -55^{\circ}\text{C to } +125^{\circ}\text{C}$

Valid Ordering Combinations

M Grade	N Grade
XQ17V16CC44M	XQ17V16VQ44N

Revision History

The following table shows the revision history for this document.

Date	Version	Revision
12/15/2003	1.0	Initial Xilinx release.
10/29/2014	1.1	Updated maximum frequency values in Dual configuration modes, page 1 . Replaced Figure 1 with updated version from DS073 . Enhanced the description of the DATA[0:7] pins and the CE pin. Clarified the description in the Controlling PROMs section. Updated notes in Figure 2 . Updated the Programming discussion. Updated the notes in Table 1 . Updated T_{HOE} description and added Notes 6 and 7 . Added T_{CEH} to Figure 3 and added Notes. Added Notes to Figure 4 . Updated copyright and added Disclaimer text.

Disclaimer

The information disclosed to you hereunder (the "Materials") is provided solely for the selection and use of Xilinx products. To the maximum extent permitted by applicable law: (1) Materials are made available "AS IS" and with all faults, Xilinx hereby DISCLAIMS ALL WARRANTIES AND CONDITIONS, EXPRESS, IMPLIED, OR STATUTORY, INCLUDING BUT NOT LIMITED TO WARRANTIES OF MERCHANTABILITY, NON-INFRINGEMENT, OR FITNESS FOR ANY PARTICULAR PURPOSE; and (2) Xilinx shall not be liable (whether in contract or tort, including negligence, or under any other theory of liability) for any loss or damage of any kind or nature related to, arising under, or in connection with, the Materials (including your use of the Materials), including for any direct, indirect, special, incidental, or consequential loss or damage (including loss of data, profits, goodwill, or any type of loss or damage suffered as a result of any action brought by a third party) even if such damage or loss was reasonably foreseeable or Xilinx had been advised of the possibility of the same. Xilinx assumes no obligation to correct any errors contained in the Materials or to notify you of updates to the Materials or to product specifications. You may not reproduce, modify, distribute, or publicly display the Materials without prior written consent. Certain products are subject to the terms and conditions of Xilinx's limited warranty, please refer to Xilinx's Terms of Sale which can be viewed at www.xilinx.com/legal.htm#tos; IP cores may be subject to warranty and support terms contained in a license issued to you by Xilinx. Xilinx products are not designed or intended to be fail-safe or for use in any application requiring fail-safe performance; you assume sole risk and liability for use of Xilinx products in such critical applications, please refer to Xilinx's Terms of Sale which can be viewed at www.xilinx.com/legal.htm#tos.

Looking for pricing, stock, or lifecycle information?

Click below to explore more details on WIN SOURCE:

 [View XQ17V16CC44M on WIN SOURCE](#)

 [Xilinx Inc. Information](#)

Optimize Your Supply Chain with WIN SOURCE Solutions

-  Global Sourcing Solution
-  Obsolete Management
-  Cost Control Management
-  Shortage Management
-  Alternative Solution
-  Excess Inventory Management