



**THE DATASHEET OF
STH180N10F3-6**



N-channel 100 V, 3.9 mΩ typ., 180 A, STripFET™ F3 Power MOSFET in H²PAK-6 package

Datasheet - production data

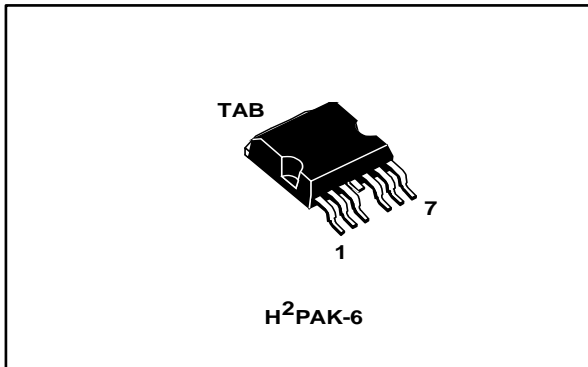
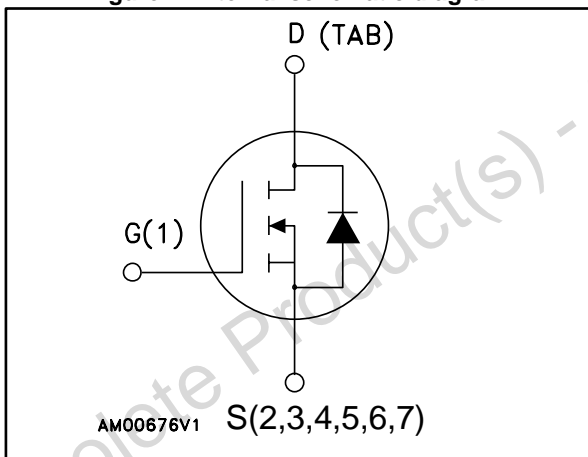

Figure 1: Internal schematic diagram



Features

Order code	V _{DS}	R _{DS(on)} max.	I _D
STH180N10F3-6	100 V	4.5 mΩ	180 A

- Low on-resistance R_{DS(on)}
- 100% avalanche tested

Applications

- Switching applications

Description

This device is an N-channel Power MOSFET developed using STripFET™ F3 technology. It is designed to minimize on-resistance and gate charge to provide superior switching performance.

Table 1: Device summary

Order code	Marking	Package	Packing
STH180N10F3-6	180N10F3	H ² PAK-6	Tape and reel

Contents

1	Electrical ratings	3
2	Electrical characteristics	4
	2.1 Electrical characteristics (curves).....	6
3	Test circuits	8
4	Package information	9
	4.1 H ² PAK-6 package information.....	9
	4.2 Packing information.....	12
5	Revision history	14

Obsolete Product(s) - Obsolete Product(s)

1 Electrical ratings

Table 2: Absolute maximum ratings

Symbol	Parameter	Value	Unit
V_{DS}	Drain-source voltage	100	V
V_{GS}	Gate-source voltage	± 20	V
$I_D^{(1)}$	Drain current (continuous) at $T_C = 25\text{ }^\circ\text{C}$	180	A
$I_D^{(1)}$	Drain current (continuous) at $T_C = 100\text{ }^\circ\text{C}$	120	A
$I_{DM}^{(2)}$	Drain current (pulsed)	720	A
P_{TOT}	Total dissipation at $T_C = 25\text{ }^\circ\text{C}$	315	W
	Derating factor	2.1	W/ $^\circ\text{C}$
dv/dt	Peak diode recovery voltage slope	20	V/ns
$E_{AS}^{(3)}$	Single pulse avalanche energy	350	mJ
T_J	Operating junction temperature	-55 to 175	$^\circ\text{C}$
T_{stg}	Storage temperature		$^\circ\text{C}$

Notes:

- (1) Current limited by package
- (2) Pulse width limited by safe operating area
- (3) Starting $T_J = 25\text{ }^\circ\text{C}$, $I_D = 80$, $V_{DD} = 50\text{ V}$

Table 3: Thermal resistance

Symbol	Parameter	Value	Unit
$R_{thj-case}$	Thermal resistance junction-case	0.48	$^\circ\text{C/W}$
$R_{thj-pcb}^{(1)}$	Thermal resistance junction-pcb	35	$^\circ\text{C/W}$

Notes:

- (1) When mounted on FR-4 board of 1 inch², 2 oz Cu

2 Electrical characteristics

($T_{CASE} = 25\text{ °C}$ unless otherwise specified)

Table 4: On/off-state

Symbol	Parameter	Test conditions	Min.	Typ.	Max.	Unit
$V_{(BR)DSS}$	Drain-source breakdown voltage ($V_{GS} = 0$)	$I_D = 250\ \mu A$	100			V
I_{DSS}	Zero gate voltage drain current ($V_{GS} = 0$)	$V_{DS} = 100\ V$			10	μA
		$V_{DS} = 100\ V$; $T_C = 125\text{ °C}$			100	μA
I_{GSS}	Gate body leakage current ($V_{DS} = 0$)	$V_{GS} = \pm 20\ V$			± 200	nA
$V_{GS(th)}$	Gate threshold voltage	$V_{DS} = V_{GS}$, $I_D = 250\ \mu A$	2		4	V
$R_{DS(on)}$	Static drain-source on-resistance	$V_{GS} = 10\ V$, $I_D = 60\ A$		3.9	4.5	m Ω

Table 5: Dynamic

Symbol	Parameter	Test conditions	Min.	Typ.	Max.	Unit	
C_{iss}	Input capacitance	$V_{DS} = 25\ V$, $f = 1\ MHz$, $V_{GS} = 0$	-	6665	-	pF	
C_{oss}	Output capacitance			786		pF	
C_{rss}	Reverse transfer capacitance			49		pF	
Q_g	Total gate charge			$V_{DD} = 50\ V$, $I_D = 120\ A$		114.6	nC
Q_{gs}	Gate-source charge			$V_{GS} = 10\ V$		38.8	nC
Q_{gd}	Gate-drain charge			See Figure 14: "Gate charge test circuit"		31.9	nC

Table 6: Switching times

Symbol	Parameter	Test conditions	Min.	Typ.	Max.	Unit
$t_{d(on)}$	Turn-on delay time	$V_{DD} = 50\ V$, $I_D = 60\ A$, $R_G = 4.7\ \Omega$, $V_{GS} = 10\ V$ See Figure 13: "Switching times test circuit for resistive load"	-	25.6	-	ns
t_r	Rise time			97.1		ns
$t_{d(off)}$	Turn-off delay time			99.9		ns
t_f	Fall time			6.9		ns

Table 7: Source-drain diode

Symbol	Parameter	Test conditions	Min.	Typ.	Max.	Unit	
I_{SD}	Source-drain current		-		180	A	
$I_{SDM}^{(1)}$	Source-drain current (pulsed)				720	A	
$V_{SD}^{(2)}$	Forward on voltage	$I_{SD} = 120 \text{ A}, V_{GS} = 0$				1.5	V
t_{rr}	Reverse recovery time	$I_{SD} = 120 \text{ A},$ $di/dt = 100 \text{ A}/\mu\text{s},$			83.4		ns
Q_{rr}	Reverse recovery charge	$V_{DD} = 80 \text{ V}, T_j = 150$ $^{\circ}\text{C}$			295.7		nC
I_{RRM}	Reverse recovery current				7.1		A

Notes:

⁽¹⁾Pulse width limited by safe operating area

⁽²⁾Pulsed: pulse duration = 300 μs , duty cycle 1.5%

Obsolete Product(s) - Obsolete Product(s)

2.1 Electrical characteristics (curves)

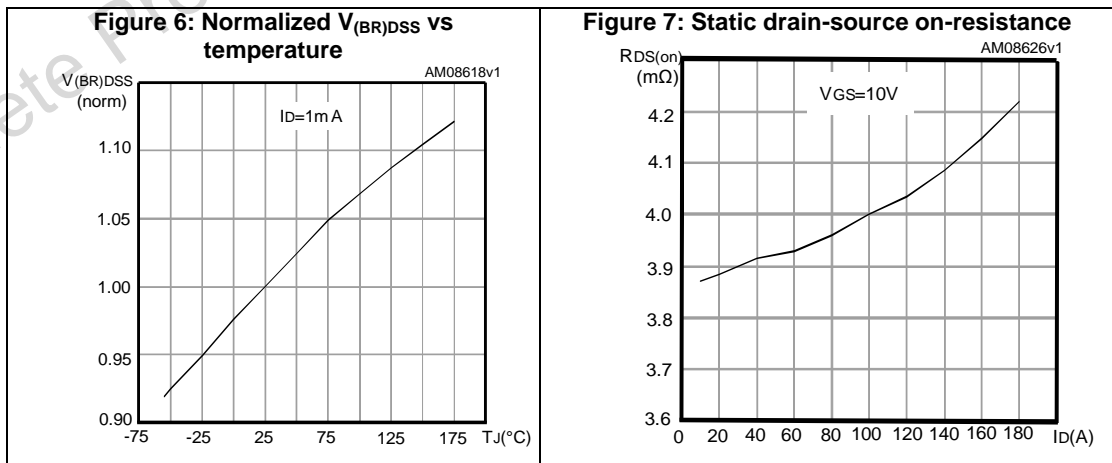
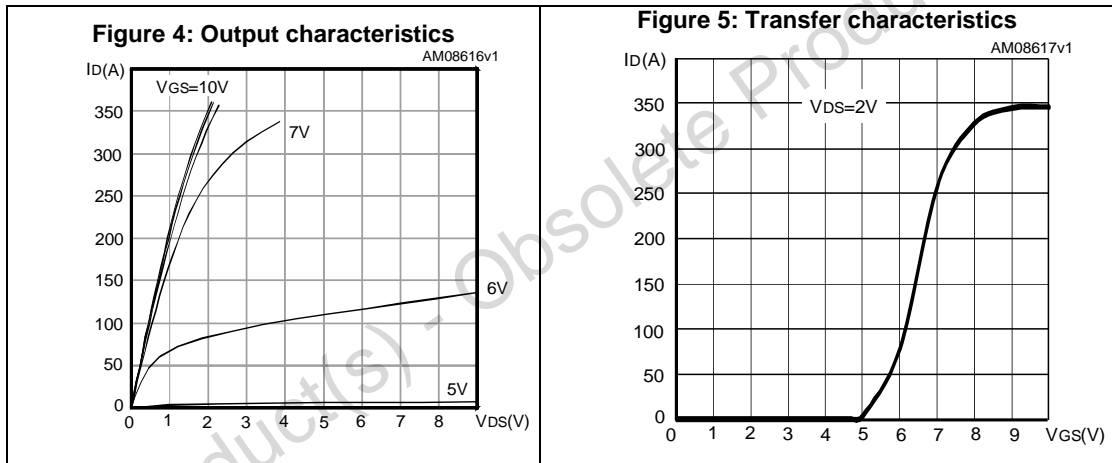
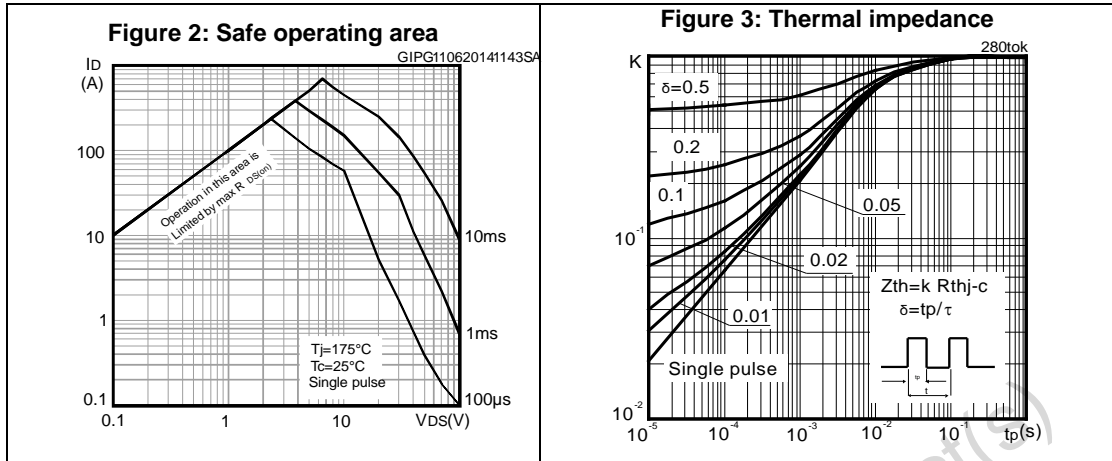

Figure 8: Gate charge vs gate-source voltage

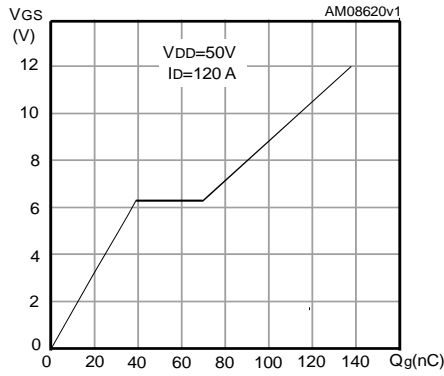

Figure 9: Capacitance variations

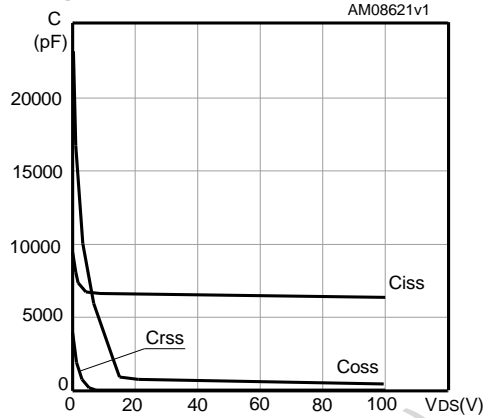

Figure 10: Normalized gate threshold voltage vs temperature

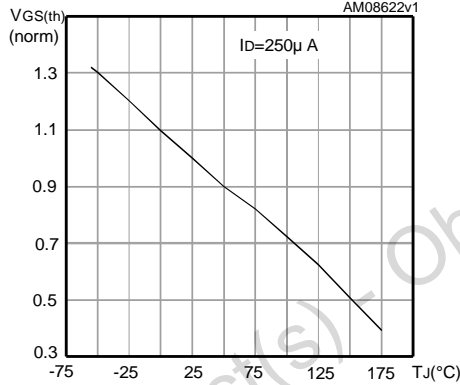

Figure 11: Normalized on-resistance vs temperature

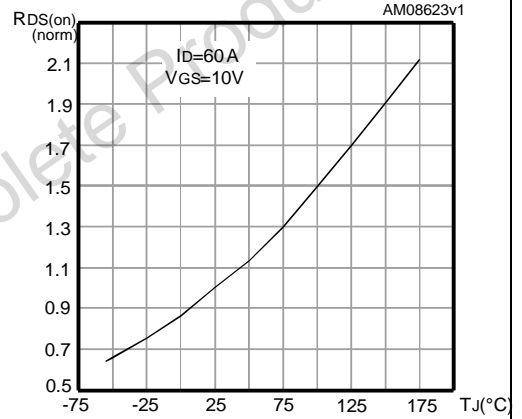
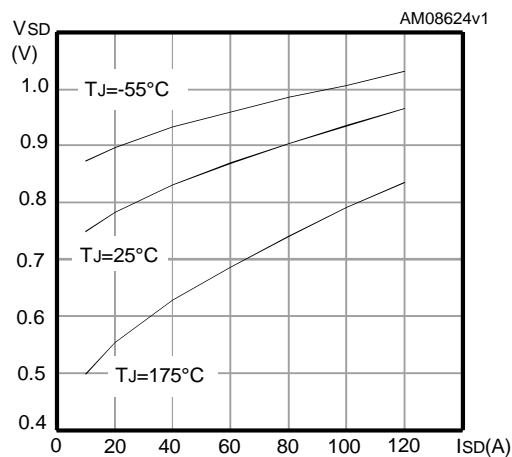
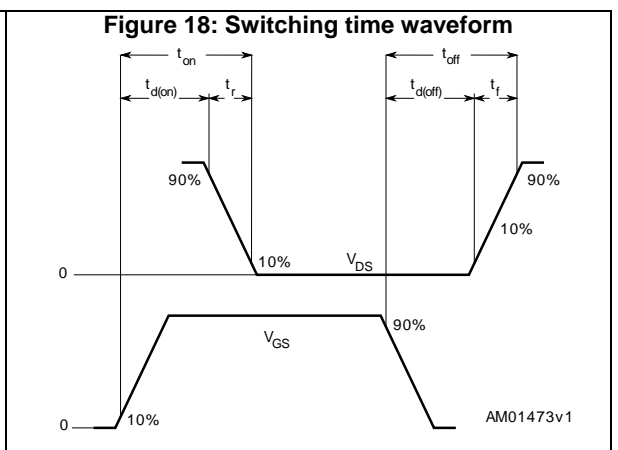
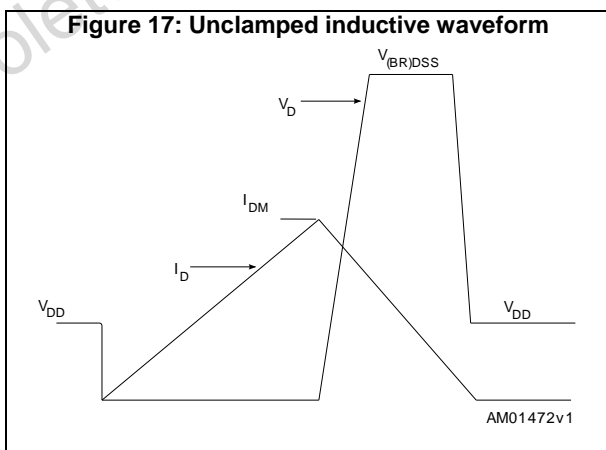
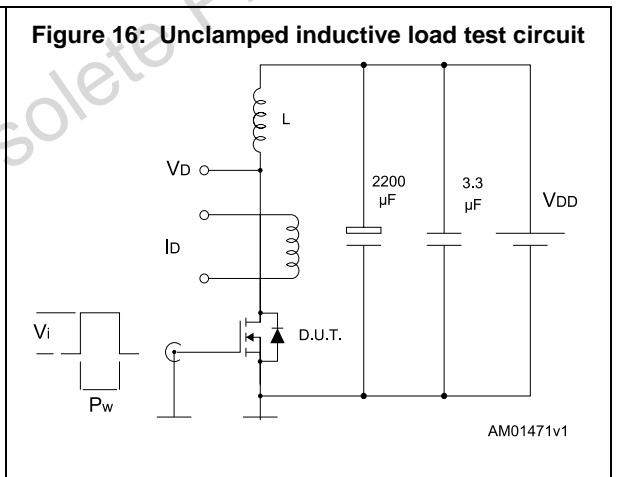
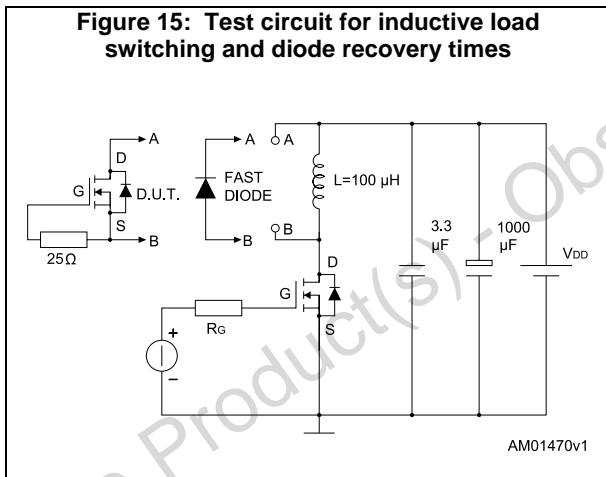
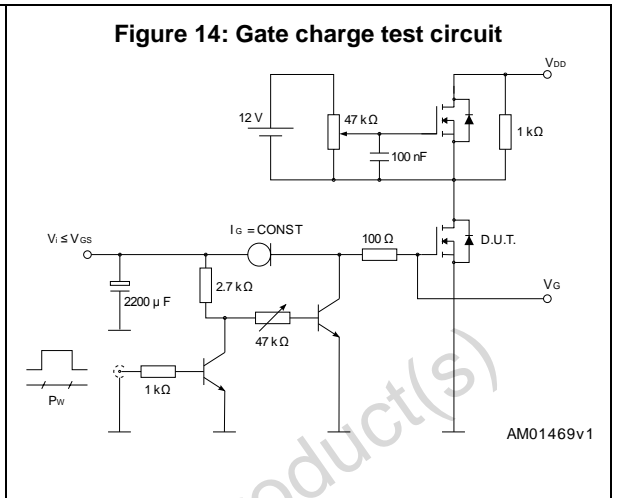
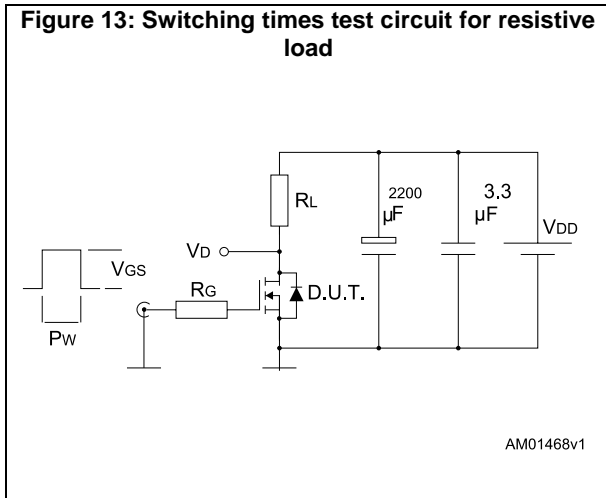

Figure 12: Source-drain diode forward characteristics



3 Test circuits



4 Package information

In order to meet environmental requirements, ST offers these devices in different grades of ECOPACK® packages, depending on their level of environmental compliance. ECOPACK® specifications, grade definitions and product status are available at: www.st.com. ECOPACK® is an ST trademark.

4.1 H²PAK-6 package information

Figure 19: H²PAK-6 outline

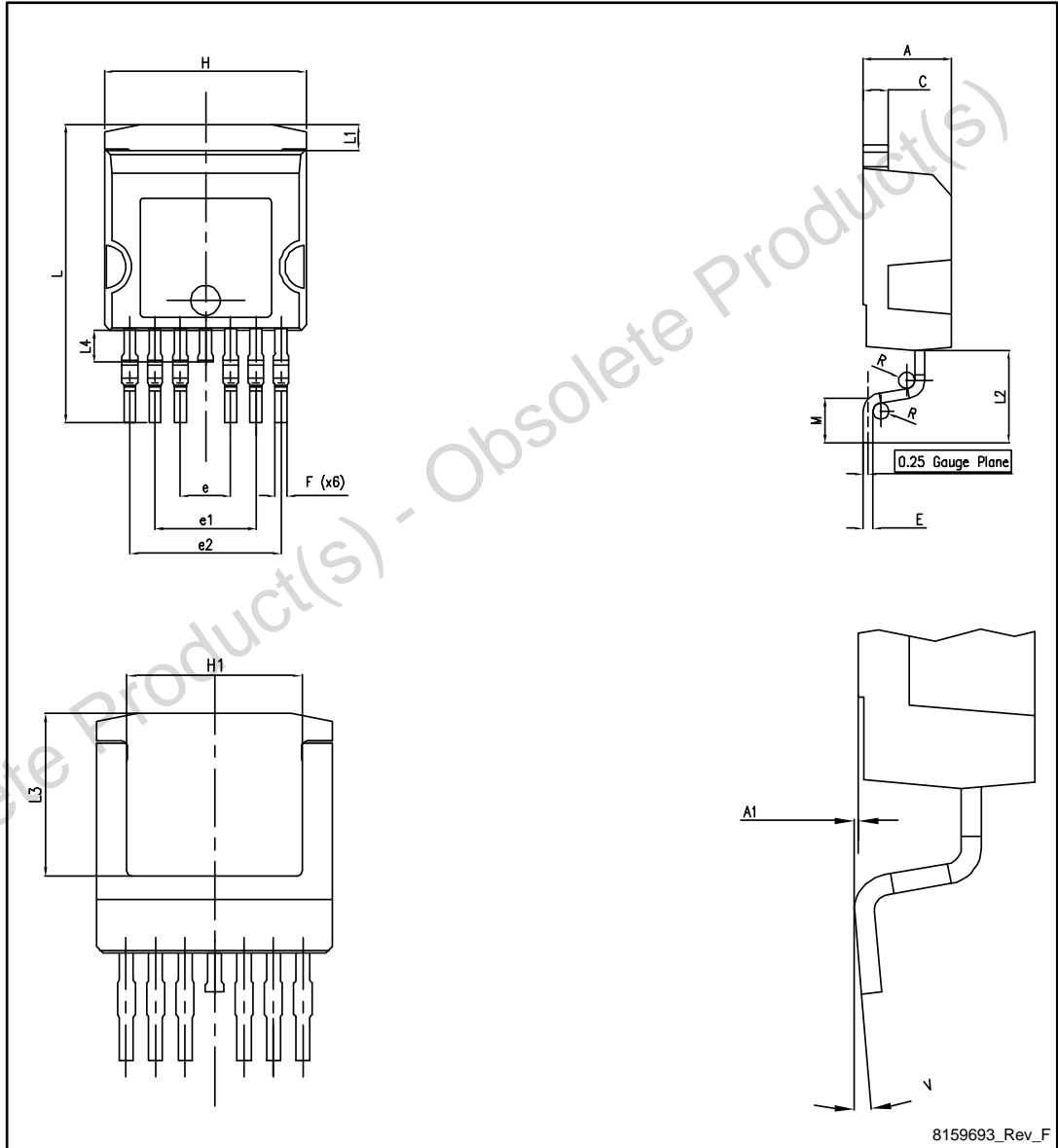
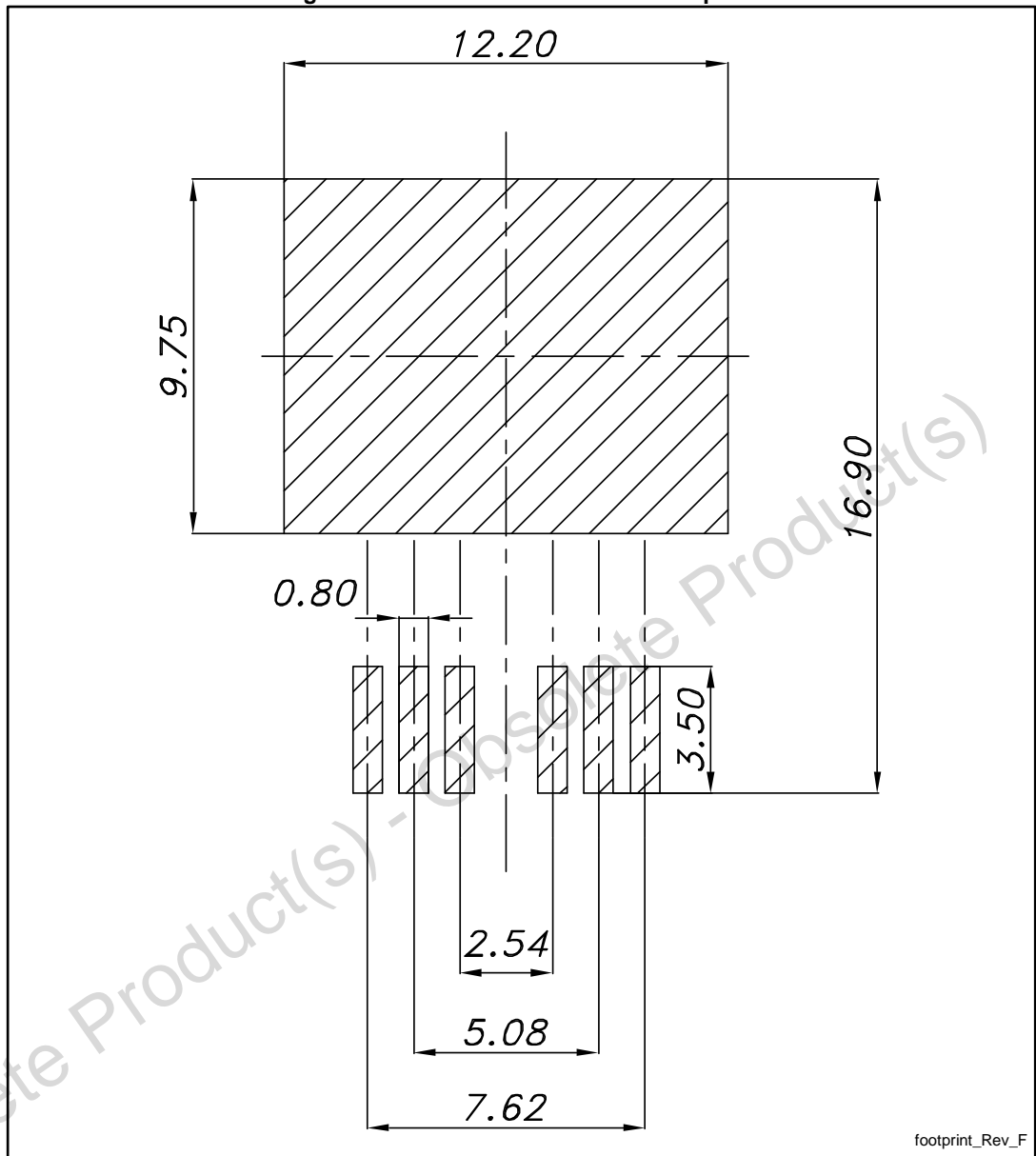

Table 8: H²PAK-6 mechanical data

Dim.	mm		
	Min.	Typ.	Max.
A	4.30		4.80
A1	0.03		0.20
C	1.17		1.37
e	2.34		2.74
e1	4.88		5.28
e2	7.42		7.82
E	0.45		0.60
F	0.50		0.70
H	10.00		10.40
H1	7.40		7.80
L	14.75		15.25
L1	1.27		1.40
L2	4.35		4.95
L3	6.85		7.25
L4	1.5		1.75
M	1.90		2.50
R	0.20		0.60
V	0°		8°

Figure 20: H²PAK-6 recommended footprint



Dimensions are in mm.

4.2 Packing information

Figure 21: Tape outline

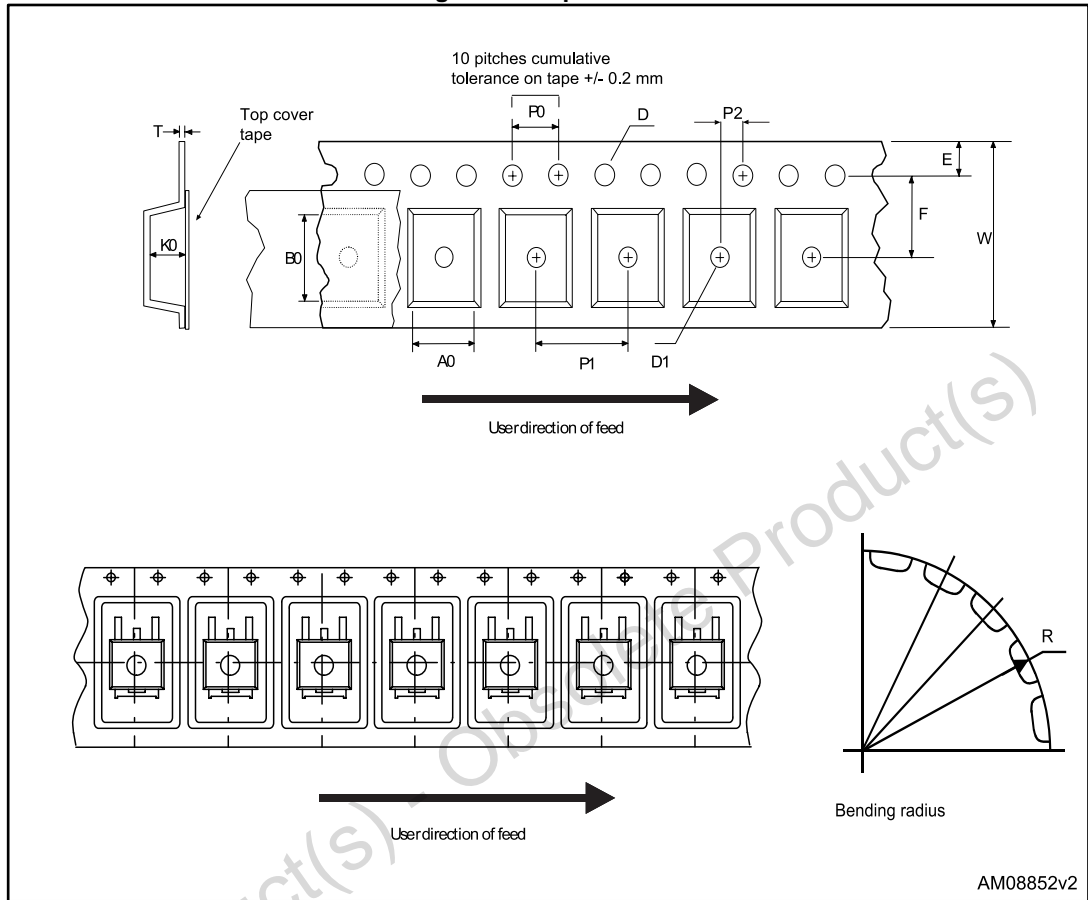

Figure 22: Reel outline

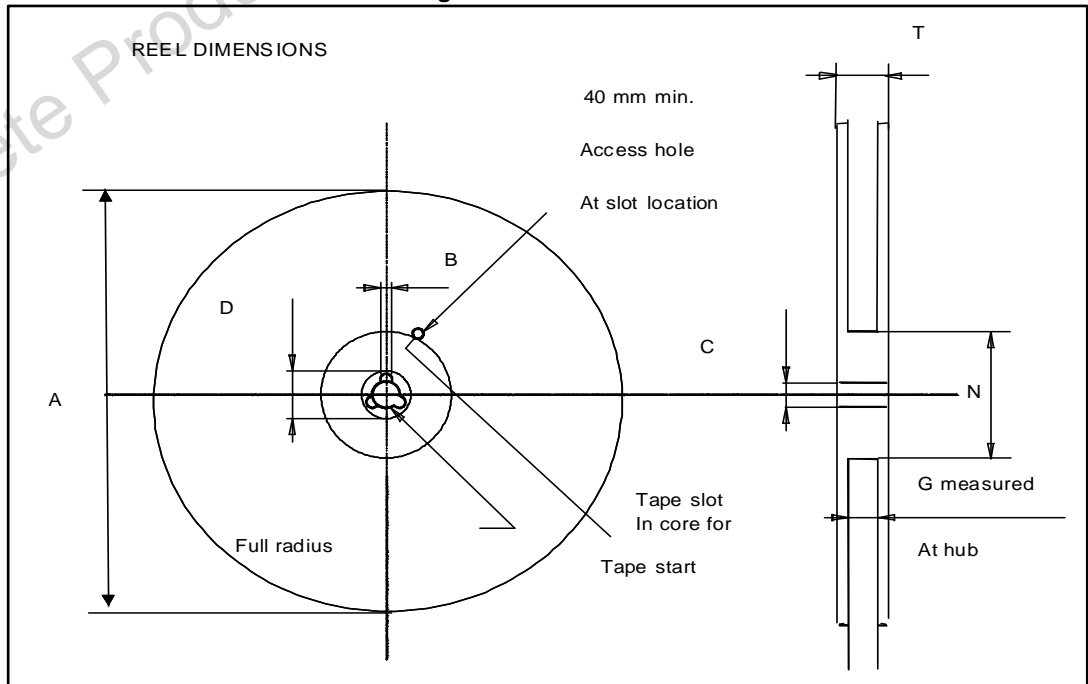

Table 9: Tape and reel mechanical data

Tape			Reel		
Dim.	mm		Dim.	mm	
	Min.	Max.		Min.	Max.
A0	10.5	10.7	A		330
B0	15.7	15.9	B	1.5	
D	1.5	1.6	C	12.8	13.2
D1	1.59	1.61	D	20.2	
E	1.65	1.85	G	24.4	26.4
F	11.4	11.6	N	100	
K0	4.8	5.0	T		30.4
P0	3.9	4.1			
P1	11.9	12.1	Base quantity		1000
P2	1.9	2.1	Bulk quantity		1000
R	50				
T	0.25	0.35			
W	23.7	24.3			

Obsolete Product(s) - Obsolete Product(s)

5 Revision history

Table 10: Document revision history

Date	Revision	Changes
10-Oct-2011	1	First version
04-Nov-2011	2	<ul style="list-style-type: none">Updated features in cover page
14-Nov-2014	3	<ul style="list-style-type: none">Updated: H²PAK-6 package mechanical data.Updated: title, features and description.Minor text changes.
26-Nov-2014	4	Updated Table 4: "On/off-state" .

Obsolete Product(s) - Obsolete Product(s)

IMPORTANT NOTICE – PLEASE READ CAREFULLY

STMicroelectronics NV and its subsidiaries ("ST") reserve the right to make changes, corrections, enhancements, modifications, and improvements to ST products and/or to this document at any time without notice. Purchasers should obtain the latest relevant information on ST products before placing orders. ST products are sold pursuant to ST's terms and conditions of sale in place at the time of order acknowledgement.

Purchasers are solely responsible for the choice, selection, and use of ST products and ST assumes no liability for application assistance or the design of Purchasers' products.

No license, express or implied, to any intellectual property right is granted by ST herein.

Resale of ST products with provisions different from the information set forth herein shall void any warranty granted by ST for such product.



ST and the ST logo are trademarks of ST. All other product or service names are the property of their respective owners.

Information in this document supersedes and replaces information previously supplied in any prior versions of this document.

© 2014 STMicroelectronics – All rights reserved

Looking for pricing, stock, or lifecycle information?

Click below to explore more details on WIN SOURCE:

-  [View **STH180N10F3-6** on WIN SOURCE](#)
-  [STMicroelectronics](#) Information

Optimize Your Supply Chain with WIN SOURCE Solutions

-  Global Sourcing Solution
-  Obsolete Management
-  Cost Control Management
-  Shortage Management
-  Alternative Solution
-  Excess Inventory Management