

SECTION A-A
SCALE 4:1

SECTION B-B
SCALE 4:1

spec ref	-	dr	Wei-Long Zhang	2012/06/14	projection	MM	size	A2	scale	1:1
tolerance std	ISO 406 ISO 1101	eng	Sunny2 Liu	2016/05/05			ecn no	ELX-DG-24036-1	rel level	Released
TOLERANCES UNLESS OTHERWISE SPECIFIED		chr	Terris Liu	2016/05/20						
surface	ASME Y14.5	linear	0.X	±0.5			VERT REC WITH ENHANCED WALLS		rev	B
		angular	0°	±2°	cat. no.		Product - Customer Drw		sheet 1 of 4	

CONTACT TYPE	TOP LAYER DESCRIPTION	TABLE 1 (HPCE / SOLDER TAILS) PLATED THROUGH-HOLE REQUIREMENTS				
		DRILLED HOLE DIAMETER	COPPER THICKNESS	TIN-LEAD THICKNESS	TIN THICKNESS	FINISHED HOLE DIAMETER
POWER & SIGNAL	TIN-LEAD	1.10-1.16 (1.15 DRILL)	0.025 - 0.050	0.005 - 0.015	--	0.94 - 1.10
	IMMERSION TIN	1.10-1.16 (1.15 DRILL)	0.025 - 0.050	--	0.9 - 1.5um	0.94 - 1.10
	COPPER (SEE NOTE 8)	1.10-1.16 (1.15 DRILL)	0.025 - 0.050	--	--	0.94 - 1.10

CONTACT TYPE	TOP LAYER DESCRIPTION	TABLE 2 (HPCE / PRESS-FIT TAILS) PLATED THROUGH-HOLE REQUIREMENTS				
		DRILLED HOLE DIAMETER	COPPER THICKNESS	TIN-LEAD THICKNESS	TIN THICKNESS	FINISHED HOLE DIAMETER
POWER & SIGNAL	TIN-LEAD	0.81-0.86 (0.85 DRILL)	0.025 - 0.050	0.005 - 0.015	--	0.65 - 0.80
	IMMERSION TIN	0.81-0.86 (0.85 DRILL)	0.025 - 0.050	--	0.9 - 1.5um	0.70 - 0.80
	COPPER (SEE NOTE 8)	0.81-0.86 (0.85 DRILL)	0.025 - 0.050	--	--	0.70 - 0.80

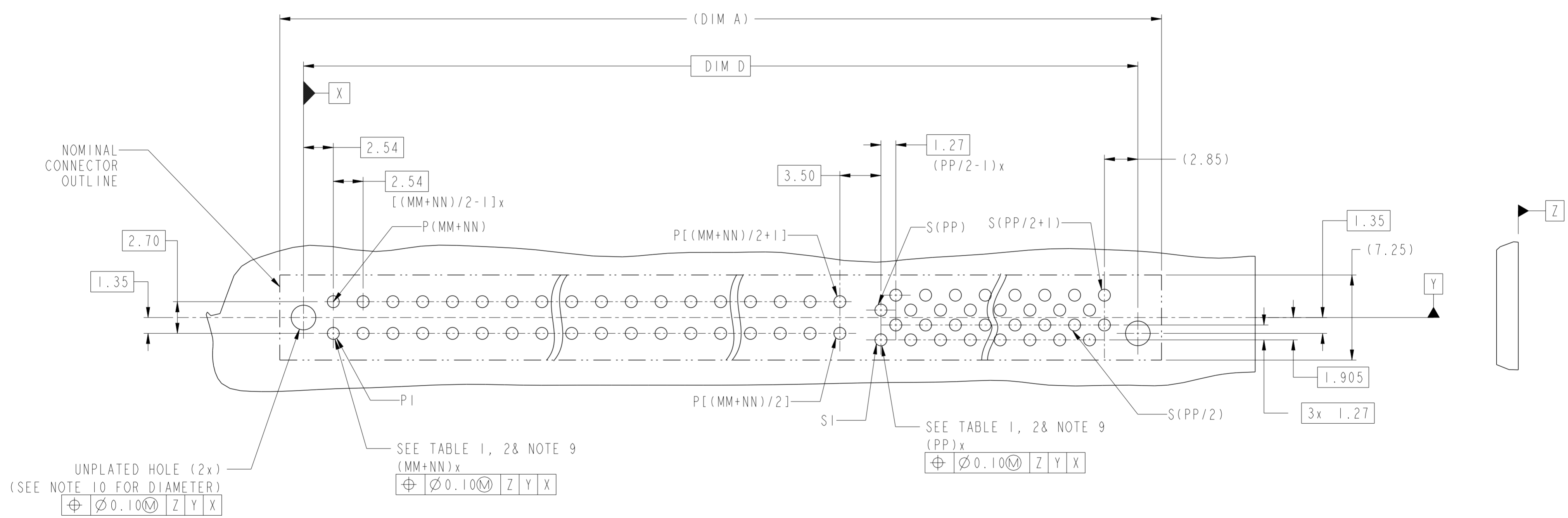

spec ref	-	dr	Wei-Long Zhang	2012/06/14	projection	MM	size	A2	scale	1:1	
tolerance std	ISO 406 ISO 1101	eng	Sunny2 Liu	2016/05/05			ecn no	ELX-DG-24036-1	rel level	Released	
TOLERANCES UNLESS OTHERWISE SPECIFIED		chr	Terris Liu	2016/05/20							
		appr	Pai-Ming Zheng	2016/05/24							
surface	ASME Y14.5	linear	0.X	±0.5	0.XX	±0.25	0.XXX	±0.10	angular	0°	±2°
Amphenol FCI		VERT REC WITH ENHANCED WALLS			HIGH POWER CARD EDGE - UNIVERSAL DRAWING		10121505		rev B		
cat. no.		Product - Customer Drw			sheet 2 of 4						

Amphenol FCI

© 2016 APCI

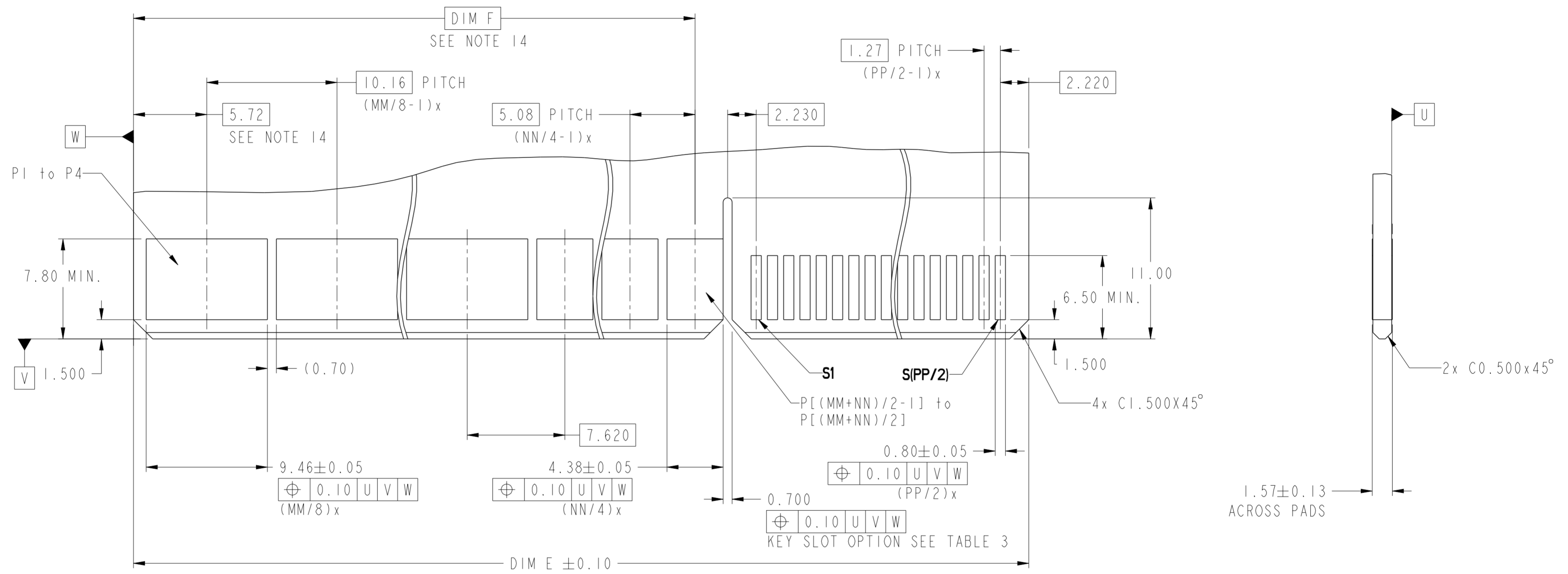

spec ref	-	dr	Wei-Long Zhang	2012/06/14	projection	MM	size	A2	scale	1:1	
tolerance std	ISO 406 ISO 1101	eng	Sunny2 Liu	2016/05/05			ecn no	ELX-DG-24036-1	rel level	Released	
TOLERANCES UNLESS OTHERWISE SPECIFIED		chr	Terris Liu	2016/05/20							
		appr	Pei-Ming Zheng	2016/05/24							
surface	ASME Y14.5	linear	0.X	±0.5	0.XX	±0.25	0.XXX	±0.10	angular	0°	±2°
Amphenol FCI		VERT REC WITH ENHANCED WALLS		HIGH POWER CARD EDGE - UNIVERSAL DRAWING		10121505		rev		B	
cat. no.		Product - Customer Drw		sheet 3 of 4							

PDS: Rev :B

STATUS:Released

Printed: May 24, 2016

10121505 - MM NN PP LF

LEAD FREE

	A	B	C	D
Polarization Key Option	Y	Y	N	N
Tail Type Note 12	STB	PF	STB	PF

QUAD PWR BEAM QTY
(NEXT TO LEFT END)

DUAL PWR BEAM QTY
(NEXT TO SIGNAL)

SIGNAL CONTACT QTY

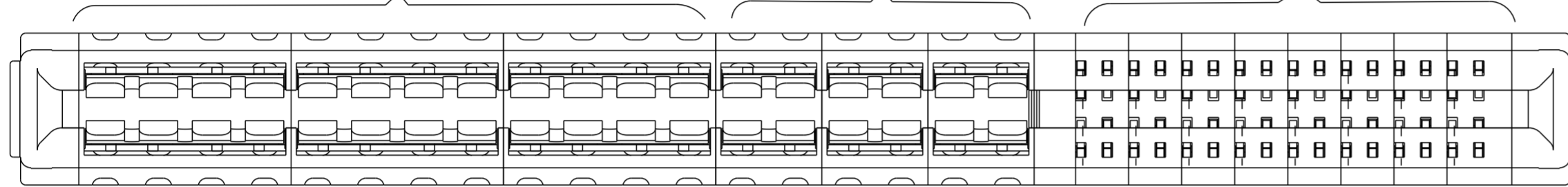

Example: The configuration above is 10121505-241232BLF
VERT Press fit 36P32S with polarization key. 24P is Quad beam contact, 12P is dual beam contact.

TABLE 3. PART NUMBER CODE. HPCE VERT P+S CONFIG

NOTES:

- CONNECTOR MATERIALS:
HOUSING: HIGH TEMPERATURE THERMAL PLASTIC, BLACK
UL 94V-0 COMPLIANT
CONTACTS: HIGH PERFORMANCE COPPER ALLOY.
- CONTACT FINISH REF. GS-12-604 SECTION 5.2.
- PRODUCT SPECIFICATION: GS-12-604.
- APPLICATION SPECIFICATION: GS-20-128.
- PRODUCT MARKING ON HOUSING IN AREA SHOWN MEETS AFCI SPECIFICATION: GS-24-007.
- PACKAGING MEETS FCI SPECIFICATION GS-14-937.
- HOUSING COMPONENT WILL WITHSTAND EXPOSURE TO 260°C PEAK TEMPERATURE FOR 60 SECONDS IN A CONVECTION, INFRA-RED, OR VAPOR PHASE REFLOW OVEN.
- COPPER PLATING THICKNESS IN CENTER OF VIA-HOLE CAN BE NO MORE THAN 0.003 LESS THAN OTHER AREAS.
- ALL HOLE SIZES ARE FINISHED HOLE SIZES.
- MOUNTING HOLES ARE UNPLATED
Ø 2.40 +/- 0.1 FOR PRESS-FIT TAILS
Ø 2.18 +/- 0.03 FOR SOLDER TAILS
- PRESS FIT APPLICATION TOOL DRAWING : 10119453.
- STB= Solder to board, 1.57-2.38mm PCB thickness.
PF = Press fit, 1.57mm minimum PCB thickness.
- MAXIMUM OVERALL LENGTH IS 100mm.
- A SYMBOL \triangle WILL BE NEXT TO ANY DIMENSION, VIEW, OR NOTE WHICH HAS BEEN MODIFIED WITH THE CURRENT DRAWING REVISION.

DIM	TABLE 2. LENGTH FORMULAS.
DIM A	$(13) (MM/8) \times 10.16 + (NN/4) \times 5.08 + (PP/2) \times 1.27 + 9.12$
DIM B	DIM "A" - 5.00
DIM C	DIM "A" - 0.94
DIM D	DIM "A" - 4.04
DIM E	DIM "A" - 5.30
DIM F	$(MM/8-1) \times 10.16 + (NN/4-1) \times 5.08 + 13.34$ (WITH 4 BEAM CONTACT)
	3.18 (WITHOUT 4 BEAM CONTACT)

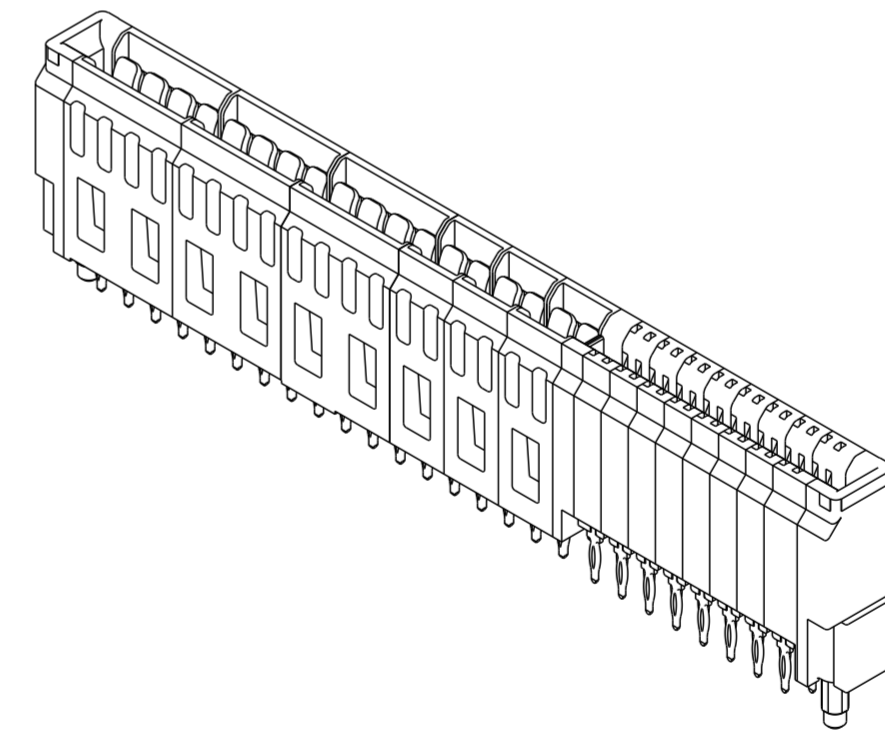

spec ref	-	dr	Wei-Long Zhang	2012/06/14	projection	MM	size	A2	scale	1:1
tolerance std	ISO 406 ISO 1101	eng	Sunny2 Liu	2016/05/05			ecn no	ELX-DG-24036-1		
TOLERANCES UNLESS OTHERWISE SPECIFIED		chr	Terris Liu	2016/05/20				rel level	Released	
surface	linear	0.X	±0.5		product family		VERT REC WITH ENHANCED WALLS			
ASME Y14.5	0.XX	±0.25	HIGH POWER CARD EDGE - UNIVERSAL DRAWING		10121505		rev		B	
	0.XXX	±0.10	cat. no.		Product - Customer Drw		sheet 4 of 4			
angular	0°	±2°								

Amphenol FCI

© 2016 AFCI

Looking for pricing, stock, or lifecycle information?

Click below to explore more details on WIN SOURCE:

 [View 10121505-320440BLF on WIN SOURCE](#)

 [Amphenol FCI Information](#)

Optimize Your Supply Chain with WIN SOURCE Solutions

-  Global Sourcing Solution
-  Obsolete Management
-  Cost Control Management
-  Shortage Management
-  Alternative Solution
-  Excess Inventory Management