

TOSHIBA CMOS Digital Integrated Circuit Silicon Monolithic

TC4051BP, TC4051BF, TC4051BFT TC4052BP, TC4052BF, TC4052BFT TC4053BP, TC4053BF, TC4053BFT

TC4051B

Single 8-Channel Multiplexer/Demultiplexer

TC4052B

Differential 4-Channel
Multiplexer/Demultiplexer

TC4053B

Triple 2-Channel Multiplexer/Demultiplexer

TC4051B, TC4052B and TC4053B are multiplexers with capabilities of selection and mixture of analog signal and digital signal. TC4051B has 8 channels configuration. TC4052B has 4 channel \times 2 configuration and TC4053B has 2 channel \times 3 configuration. The digital signal to the control terminal turns "ON" the corresponding switch of each channel, with large amplitude ($V_{DD} - V_{EE}$) can be switched by the control signal with small logical amplitude ($V_{DD} - V_{SS}$). For example, in the case of $V_{DD} = 5\text{ V}$, $V_{SS} = 0\text{ V}$ and $V_{EE} = -5\text{ V}$, signals between -5 V and $+5\text{ V}$ can be switched from the logical circuit with single power supply of 5 volts. As the ON-resistance of each switch is low, these can be connected to the circuits with low input impedance.

TC4051BP, TC4052BP, TC4053BP

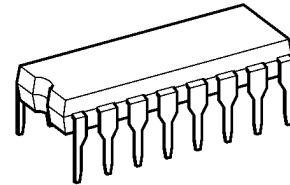

DIP16-P-300-2.54A

TC4051BF, TC4052BF, TC4053BF

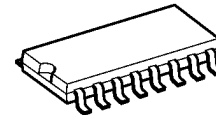

SOP16-P-300-1.27A

TC4051BFT, TC4052BFT, TC4053BFT

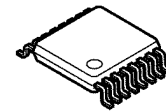

TSSOP16-P-0044-0.65A

Weight

DIP16-P-300-2.54A	: 1.00 g (typ.)
SOP16-P-300-1.27A	: 0.18 g (typ.)
TSSOP16-P-0044-0.65A	: 0.06 g (typ.)

Start of commercial production
1978-04

Pin Assignment (top view)

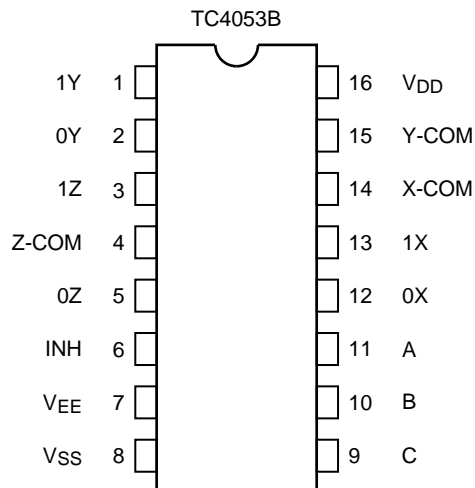
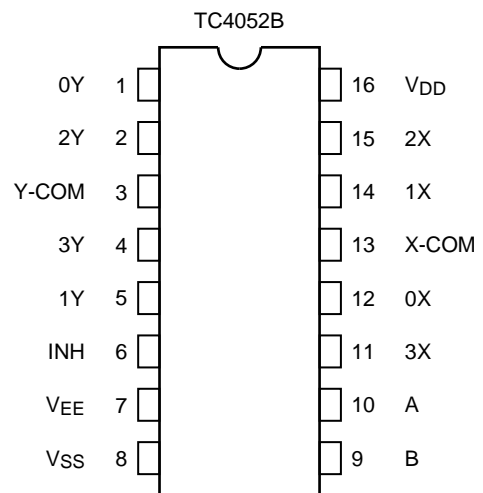
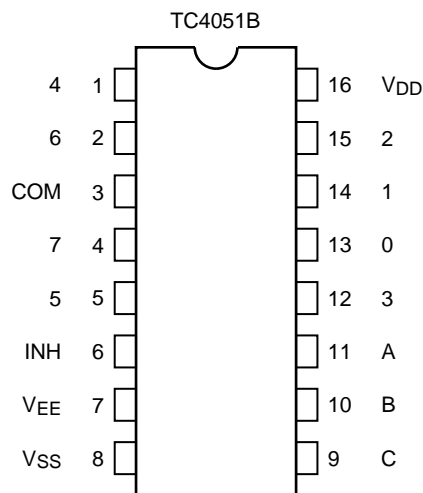

Truth Table

Control Inputs				"ON" Channel		
Inhibit	C Δ	B	A	TC4051B	TC4052B	TC4053B
L	L	L	L	0	0X, 0Y	0X, 0Y, 0Z
L	L	L	H	1	1X, 1Y	1X, 0Y, 0Z
L	L	H	L	2	2X, 2Y	0X, 1Y, 0Z
L	L	H	H	3	3X, 3Y	1X, 1Y, 0Z
L	H	L	L	4	—	0X, 0Y, 1Z
L	H	L	H	5	—	1X, 0Y, 1Z
L	H	H	L	6	—	0X, 1Y, 1Z
L	H	H	H	7	—	1X, 1Y, 1Z
H	X	X	X	None	None	None

X: Don't care

Δ : Except TC4052B

Logic Diagram

TC4051B

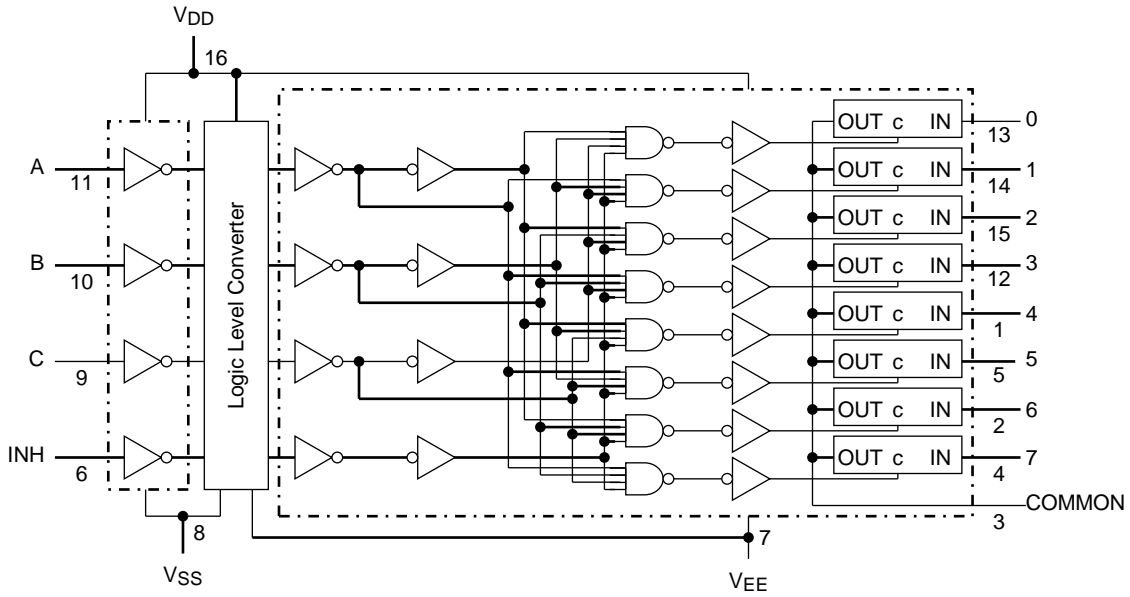

TC4052B

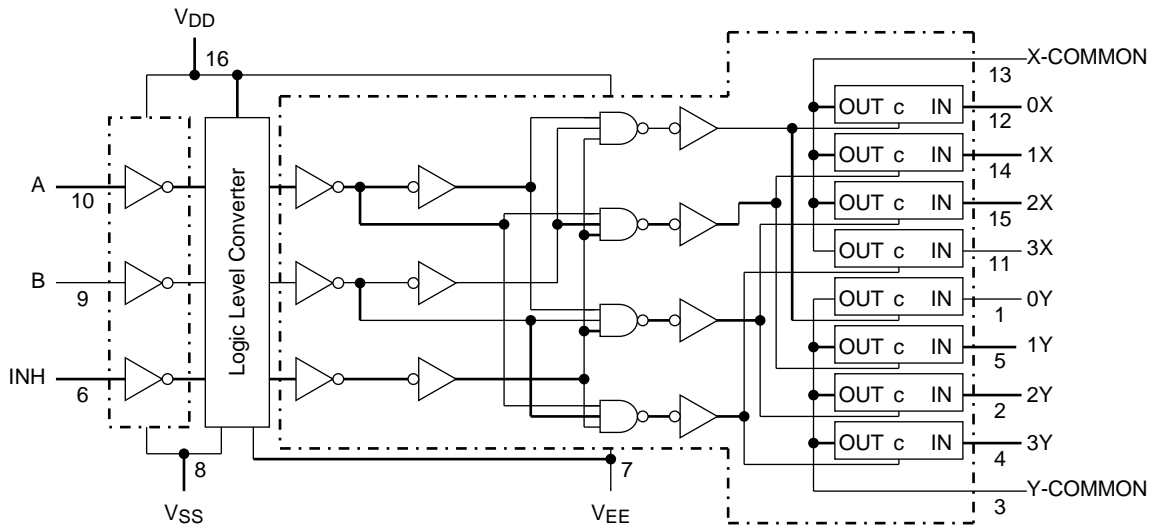

TC4053B

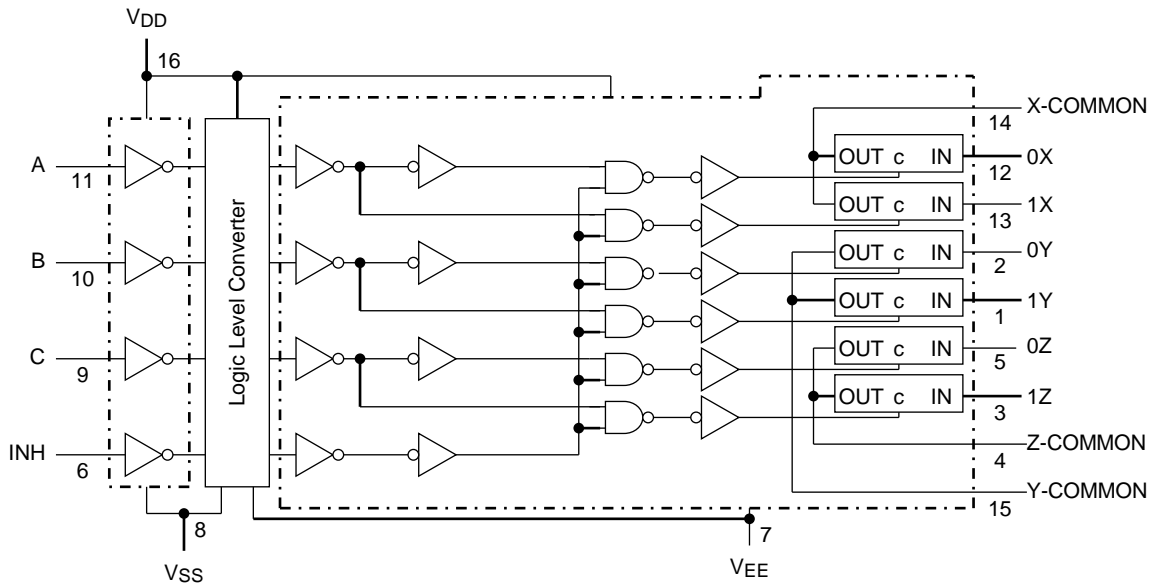

Truth Table

Control C	Impedance between IN-OUT (Note)
H	$0.5 \text{ to } 5 \times 10^2 \Omega$
L	$>10^9 \Omega$

Note: See electrical characteristics

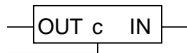

Absolute Maximum Ratings (Note)

Characteristics	Symbol	Rating	Unit
DC supply voltage	$V_{DD}-V_{SS}$	-0.5 to 20	V
DC supply voltage	$V_{DD}-V_{EE}$	-0.5 to 20	V
Control input voltage	V_{CIN}	$V_{SS} - 0.5 \text{ to } V_{DD} + 0.5$	V
Switch I/O voltage	V_I/V_O	$V_{EE} - 0.5 \text{ to } V_{DD} + 0.5$	V
Control input current	I_{CIN}	± 10	mA
Potential difference across I/O during ON	V_I-V_O	-0.5 to 0.5	V
Power dissipation	P_D	300 (DIP)/180 (SOP/TSSOP)	mW
Operating temperature range	T_{opr}	-40 to 85	$^{\circ}\text{C}$
Storage temperature range	T_{stg}	-65 to 150	$^{\circ}\text{C}$

Note: Exceeding any of the absolute maximum ratings, even briefly, lead to deterioration in IC performance or even destruction.

Using continuously under heavy loads (e.g. the application of high temperature/current/voltage and the significant change in temperature, etc.) may cause this product to decrease in the reliability significantly even if the operating conditions (i.e. operating temperature/current/voltage, etc.) are within the absolute maximum ratings and the operating ranges.

Please design the appropriate reliability upon reviewing the Toshiba Semiconductor Reliability Handbook ("Handling Precautions"/"Derating Concept and Methods") and individual reliability data (i.e. reliability test report and estimated failure rate, etc).

Operating Ranges (Note)

Characteristics	Symbol	Test Condition	Min	Typ.	Max	Unit
DC supply voltage	VDD-VSS	—	3	—	18	V
	VDD-VEE	—	3	—	18	
Control input voltage	V _{IN}	—	V _{SS}	—	V _{DD}	V
Input/output voltage	V _{IN} /V _{OUT}	—	V _{EE}	—	V _{DD}	V

Note: The operating ranges must be maintained to ensure the normal operation of the device.
Unused Control inputs must be tied to either V_{DD} or V_{SS}.

Static Electrical Characteristics

Characteristics	Symbol	Test Condition	-40°C			25°C			85°C		Unit		
			V _{SS} (V)	V _{EE} (V)	V _{DD} (V)	Min	Max	Min	Typ.	Max		Min	Max
Control input high voltage	V _{IH}	V _{IS} = V _{DD} thru 1 kΩ	V _{EE} = V _{SS} R _L = 1 kΩ to V _{SS} I _{IS} < 2 μA on all OFF channels	5	3.5	—	3.5	2.75	—	3.5	—	V	
				10	7.0	—	7.0	5.50	—	7.0	—		
				15	11.0	—	11.0	8.25	—	11.0	—		
Control input low voltage	V _{IL}			5	—	1.5	—	2.25	1.5	—	1.5	V	
				10	—	3.0	—	4.5	3.0	—	3.0		
				15	—	4.0	—	6.75	4.0	—	4.0		
On-state resistance	R _{ON}	0 ≤ V _{IS} ≤ V _{DD} R _L = 10 kΩ	0	0	5	—	850	—	240	950	—	1200	Ω
			0	0	10	—	210	—	110	250	—	300	
			0	0	15	—	140	—	80	160	—	200	
ΔOn-state resistance between any 2 switches	R _{ONΔ}	—	0	0	5	—	—	—	10	—	—	—	Ω
			0	0	10	—	—	—	6	—	—	—	
			0	0	15	—	—	—	4	—	—	—	
Input/output leakage current	I _{OFF}	V _{IN} = 18 V, V _{OUT} = 0 V	18	—	±100	—	±0.01	±100	—	±1000	nA		
		V _{IN} = 0 V, V _{OUT} = 18 V	18	—	±100	—	±0.01	±100	—	±1000			
Quiescent supply current	I _{DD}	V _{IN} = V _{SS} , V _{DD}	(Note)	5	—	5.0	—	0.005	5.0	—	150	μA	
				10	—	10	—	0.010	10	—	300		
				15	—	20	—	0.015	20	—	600		
Input current	I _{IN}	V _{IH} = 18 V	18	—	0.1	—	10 ⁻⁵	0.1	—	1.0	μA		
		V _{IL} = 0 V	18	—	-0.1	—	-10 ⁻⁵	-0.1	—	-1.0			
Input capacitance	C _{IN}	—	—	—	—	—	5	7.5	—	—	pF		
Switch input capacitance	C _{IN}	—	—	—	—	—	10	—	—	—	pF		
Output capacitance	C _{OUT}	TC4051B	10	—	—	—	58	—	—	—	pF		
		TC4052B	10	—	—	—	30	—	—	—			
		TC4053B	10	—	—	—	17	—	—	—			
Feedthrough capacitance	C _{IN} - C-OUT	TC4051B	10	—	—	—	0.2	—	—	—	pF		
		TC4052B	10	—	—	—	0.2	—	—	—			
		TC4053B	10	—	—	—	0.2	—	—	—			

Note: All valid input combinations.

Switching Characteristics (Ta = 25°C, CL = 50 pF)

Characteristics	Symbol	Test Condition			Min	Typ.	Max	Unit		
		VSS (V)	VEE (V)	VDD (V)						
Phase difference between input to output	φI-O	—	0	0	5	—	15	45	ns	
			0	0	10	—	8	20		
			0	0	15	—	6	15		
Propagation delay time (A, B, C, -OUT)	tpZL tpZH tpLZ tpHZ	RL = 1 kΩ	0	0	5	—	170	550	ns	
			0	0	10	—	90	240		
			0	0	15	—	70	160		
			0	-5	5	—	100	240		
			0	-7.5	7.5	—	80	160		
Propagation delay time (INH-OUT)	tpZL tpZH	RL = 1 kΩ	0	0	5	—	120	380	ns	
			0	0	10	—	60	200		
			0	0	15	—	50	160		
			0	-5	5	—	80	200		
			0	-7.5	7.5	—	60	160		
Propagation delay time (INH-OUT)	tpLZ tpHZ	RL = 1 kΩ	0	0	5	—	170	450	ns	
			0	0	10	—	90	210		
			0	0	15	—	70	160		
			0	-5	5	—	100	210		
			0	-7.5	7.5	—	80	160		
-3dB cutoff frequency TC4051B TC4052B TC4053B	fmax (I-O)	RL = 1 kΩ	(Note 1)	-5	-5	5	—	20	—	MHz
				-5	-5	5	—	30	—	
				-5	-5	5	—	40	—	
Total harmonic distortion	—	RL = 10 kΩ f = 1 kHz	(Note 2)	-2.5	-2.5	2.5	—	0.15	—	%
				-5	-5	5	—	0.03	—	
				-7.5	-7.5	7.5	—	0.02	—	
-50dB feedthrough (switch off)	—	RL = 1 kΩ	(Note 3)	-5	-5	5	—	500	—	kHz
Crosstalk	—	RL = 1 kΩ	(Note 4)	-5	-5	5	—	1.5	—	MHz
Crosstalk (control-OUT)	—	RLIN = 1 kΩ		0	0	5	—	200	—	mV
		ROUT = 10 kΩ		0	0	10	—	400	—	
		CL = 15 pF		0	0	15	—	600	—	

Note 1: Sine wave of ± 2.5 Vp-p shall be used for Vis and the frequency of $20 \log_{10} \frac{V_{OS}}{V_{is}} = -3\text{dB}$ shall be fmax.

Note 2: Vis shall be sine wave of $\pm \left(\frac{V_{DD} - V_{EE}}{4} \right)$ p-p.

Note 3: Sine wave of ± 2.5 Vp-p shall be used for Vis and the frequency of $20 \log_{10} \frac{V_{OS}}{V_{is}} = -50\text{dB}$ shall be feed-through.

Note 4: Sine wave of ± 2.5 Vp-p shall be used for Vis and the frequency of $20 \log_{10} \frac{V_{OS}}{V_{is}} = -50\text{dB}$ shall be crosstalk.

Package Dimensions

DIP16-P-300-2.54A

Unit : mm

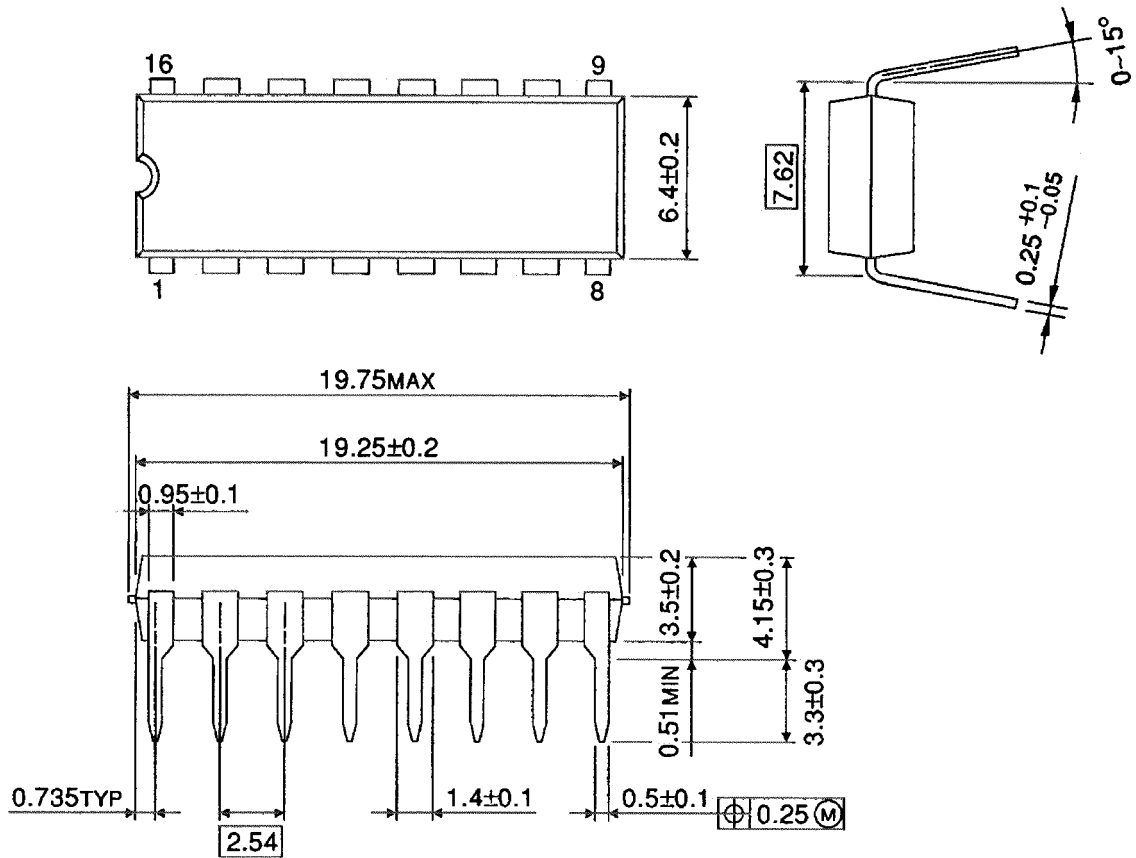

Weight: 1.00 g (typ.)

Package Dimensions

SOP16-P-300-1.27A

Unit: mm

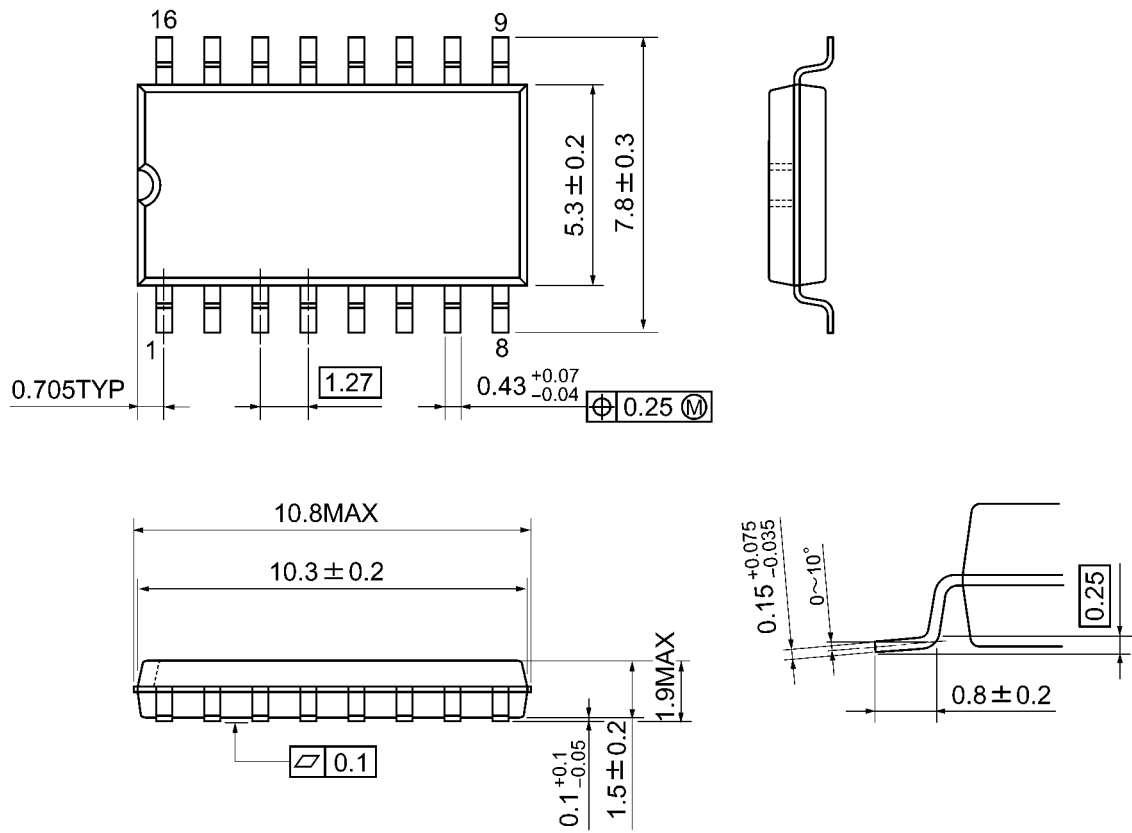

Weight: 0.18 g (typ.)

Package Dimensions

TSSOP16-P-0044-0.65A

Unit: mm

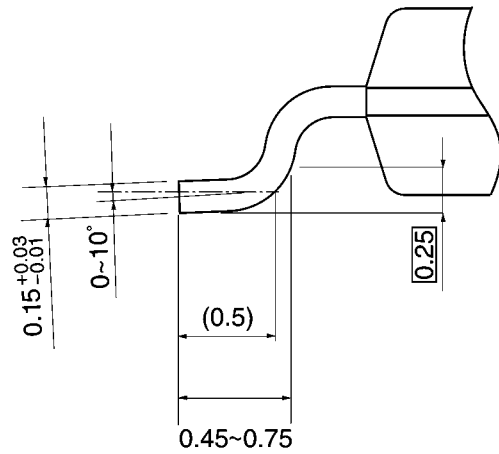
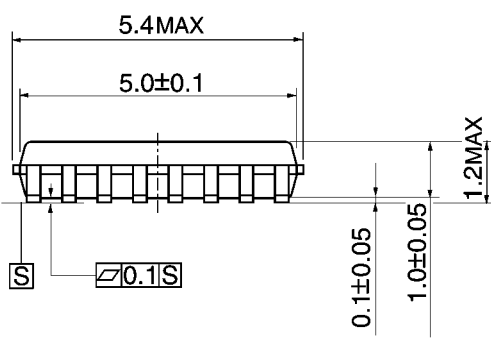
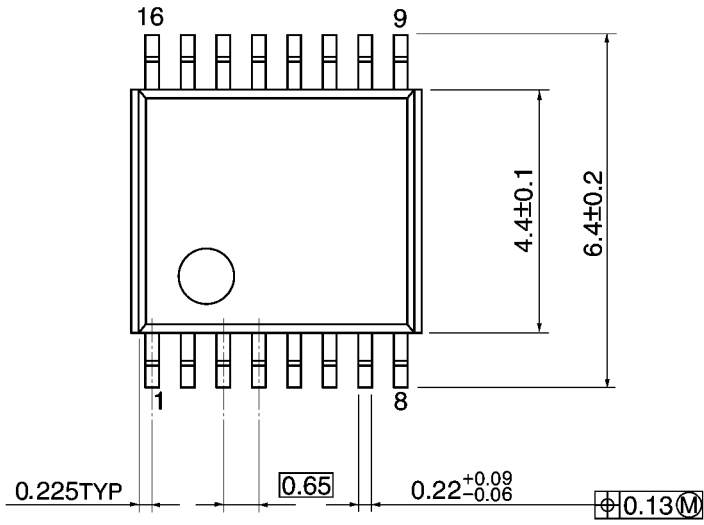



Weight: 0.06 g (typ.)

RESTRICTIONS ON PRODUCT USE

- Toshiba Corporation, and its subsidiaries and affiliates (collectively "TOSHIBA"), reserve the right to make changes to the information in this document, and related hardware, software and systems (collectively "Product") without notice.
- This document and any information herein may not be reproduced without prior written permission from TOSHIBA. Even with TOSHIBA's written permission, reproduction is permissible only if reproduction is without alteration/omission.
- Though TOSHIBA works continually to improve Product's quality and reliability, Product can malfunction or fail. Customers are responsible for complying with safety standards and for providing adequate designs and safeguards for their hardware, software and systems which minimize risk and avoid situations in which a malfunction or failure of Product could cause loss of human life, bodily injury or damage to property, including data loss or corruption. Before customers use the Product, create designs including the Product, or incorporate the Product into their own applications, customers must also refer to and comply with (a) the latest versions of all relevant TOSHIBA information, including without limitation, this document, the specifications, the data sheets and application notes for Product and the precautions and conditions set forth in the "TOSHIBA Semiconductor Reliability Handbook" and (b) the instructions for the application with which the Product will be used with or for. Customers are solely responsible for all aspects of their own product design or applications, including but not limited to (a) determining the appropriateness of the use of this Product in such design or applications; (b) evaluating and determining the applicability of any information contained in this document, or in charts, diagrams, programs, algorithms, sample application circuits, or any other referenced documents; and (c) validating all operating parameters for such designs and applications. **TOSHIBA ASSUMES NO LIABILITY FOR CUSTOMERS' PRODUCT DESIGN OR APPLICATIONS.**
- **PRODUCT IS NEITHER INTENDED NOR WARRANTED FOR USE IN EQUIPMENTS OR SYSTEMS THAT REQUIRE EXTRAORDINARILY HIGH LEVELS OF QUALITY AND/OR RELIABILITY, AND/OR A MALFUNCTION OR FAILURE OF WHICH MAY CAUSE LOSS OF HUMAN LIFE, BODILY INJURY, SERIOUS PROPERTY DAMAGE AND/OR SERIOUS PUBLIC IMPACT ("UNINTENDED USE").** Except for specific applications as expressly stated in this document, Unintended Use includes, without limitation, equipment used in nuclear facilities, equipment used in the aerospace industry, medical equipment, equipment used for automobiles, trains, ships and other transportation, traffic signaling equipment, equipment used to control combustions or explosions, safety devices, elevators and escalators, devices related to electric power, and equipment used in finance-related fields. **IF YOU USE PRODUCT FOR UNINTENDED USE, TOSHIBA ASSUMES NO LIABILITY FOR PRODUCT.** For details, please contact your TOSHIBA sales representative.
- Do not disassemble, analyze, reverse-engineer, alter, modify, translate or copy Product, whether in whole or in part.
- Product shall not be used for or incorporated into any products or systems whose manufacture, use, or sale is prohibited under any applicable laws or regulations.
- The information contained herein is presented only as guidance for Product use. No responsibility is assumed by TOSHIBA for any infringement of patents or any other intellectual property rights of third parties that may result from the use of Product. No license to any intellectual property right is granted by this document, whether express or implied, by estoppel or otherwise.
- **ABSENT A WRITTEN SIGNED AGREEMENT, EXCEPT AS PROVIDED IN THE RELEVANT TERMS AND CONDITIONS OF SALE FOR PRODUCT, AND TO THE MAXIMUM EXTENT ALLOWABLE BY LAW, TOSHIBA (1) ASSUMES NO LIABILITY WHATSOEVER, INCLUDING WITHOUT LIMITATION, INDIRECT, CONSEQUENTIAL, SPECIAL, OR INCIDENTAL DAMAGES OR LOSS, INCLUDING WITHOUT LIMITATION, LOSS OF PROFITS, LOSS OF OPPORTUNITIES, BUSINESS INTERRUPTION AND LOSS OF DATA, AND (2) DISCLAIMS ANY AND ALL EXPRESS OR IMPLIED WARRANTIES AND CONDITIONS RELATED TO SALE, USE OF PRODUCT, OR INFORMATION, INCLUDING WARRANTIES OR CONDITIONS OF MERCHANTABILITY, FITNESS FOR A PARTICULAR PURPOSE, ACCURACY OF INFORMATION, OR NONINFRINGEMENT.**
- Do not use or otherwise make available Product or related software or technology for any military purposes, including without limitation, for the design, development, use, stockpiling or manufacturing of nuclear, chemical, or biological weapons or missile technology products (mass destruction weapons). Product and related software and technology may be controlled under the applicable export laws and regulations including, without limitation, the Japanese Foreign Exchange and Foreign Trade Law and the U.S. Export Administration Regulations. Export and re-export of Product or related software or technology are strictly prohibited except in compliance with all applicable export laws and regulations.
- Please contact your TOSHIBA sales representative for details as to environmental matters such as the RoHS compatibility of Product. Please use Product in compliance with all applicable laws and regulations that regulate the inclusion or use of controlled substances, including without limitation, the EU RoHS Directive. **TOSHIBA ASSUMES NO LIABILITY FOR DAMAGES OR LOSSES OCCURRING AS A RESULT OF NONCOMPLIANCE WITH APPLICABLE LAWS AND REGULATIONS.**

Looking for pricing, stock, or lifecycle information?

Click below to explore more details on WIN SOURCE:

-  [View TC4053BFTEL on WIN SOURCE](#)
-  [Toshiba Semiconductor and Storage Information](#)

Optimize Your Supply Chain with WIN SOURCE Solutions

-  Global Sourcing Solution
-  Obsolete Management
-  Cost Control Management
-  Shortage Management
-  Alternative Solution
-  Excess Inventory Management