



Atmel 8-bit Microcontroller with 16K Bytes In-System Programmable Flash

AT90PWM216 /AT90PWM316 Summary

Features

- High Performance, Low Power AVR® 8-bit Microcontroller
- Advanced RISC Architecture
 - 129 Powerful Instructions - Most Single Clock Cycle Execution
 - 32 x 8 General Purpose Working Registers
 - Fully Static Operation
 - Up to 1 MIPS throughput per MHz
 - On-chip 2-cycle Multiplier
- Data and Non-Volatile Program Memory
 - 16K Bytes Flash of In-System Programmable Program Memory
 - Endurance: 10,000 Write/Erase Cycles
 - Optional Boot Code Section with Independent Lock Bits
- In-System Programming by On-chip Boot Program
- True Read-While-Write Operation
 - 512 Bytes of In-System Programmable EEPROM
- Endurance: 100,000 Write/Erase Cycles
 - 1024 Bytes Internal SRAM
 - Programming Lock for Flash Program and EEPROM Data Security
- On Chip Debug Interface (debugWIRE)
- Peripheral Features
 - Two or three 12-bit High Speed PSC (Power Stage Controllers) with 4-bit Resolution Enhancement
 - Non Overlapping Inverted PWM Output Pins With Flexible Dead-Time
 - Variable PWM duty Cycle and Frequency
 - Synchronous Update of all PWM Registers
 - Auto Stop Function for Event Driven PFC Implementation
 - Less than 25Hz Step Width at 150kHz Output Frequency
 - PSC2 with four Output Pins and Output Matrix
 - One 8-bit General purpose Timer/Counter with Separate Prescaler and Capture Mode
 - One 16-bit General purpose Timer/Counter with Separate Prescaler, Compare Mode and Capture Mode
 - Programmable Serial USART
 - Standard UART mode
 - 16/17 bit Biphase Mode for DALI Communications
 - Master/Slave SPI Serial Interface
 - 10-bit ADC
 - Up To 11 Single Ended Channels and 2 Fully Differential ADC Channel Pairs
 - Programmable Gain (5x, 10x, 20x, 40x on Differential Channels)
 - Internal Reference Voltage
 - 10-bit DAC
 - Two or three Analog Comparator with Resistor-Array to Adjust Comparison Voltage
 - 4 External Interrupts
 - Programmable Watchdog Timer with Separate On-Chip Oscillator
- Special Microcontroller Features
 - Low Power Idle, Noise Reduction, and Power Down Modes
 - Power On Reset and Programmable Brown Out Detection
 - Flag Array in Bit-programmable I/O Space (4 bytes)
 - In-System Programmable via SPI Port
 - Internal Calibrated RC Oscillator (8 MHz)
 - On-chip PLL for fast PWM (32 MHz, 64 MHz) and CPU (16 MHz)
- Operating Voltage: 2.7V - 5.5V
- Extended Operating Temperature:
 - -40°C to +105°C



Product	Package	12 bit PWM with deadtime	ADC Input	ADC Diff	Analog Comparator	Application
AT90PWM216	SO24	2 x 2	8	1	2	One fluorescent ballast
AT90PWM316	SO32, QFN32	3 x 2	11	2	3	HID ballast, fluorescent ballast, Motor control

1. Disclaimer

Typical values contained in this datasheet are based on simulations and characterization of other AVR microcontrollers manufactured on the same process technology. Min and Max values will be available after the device is characterized.

2. Pin Configurations

Figure 2-1. SOIC 24-pin Package

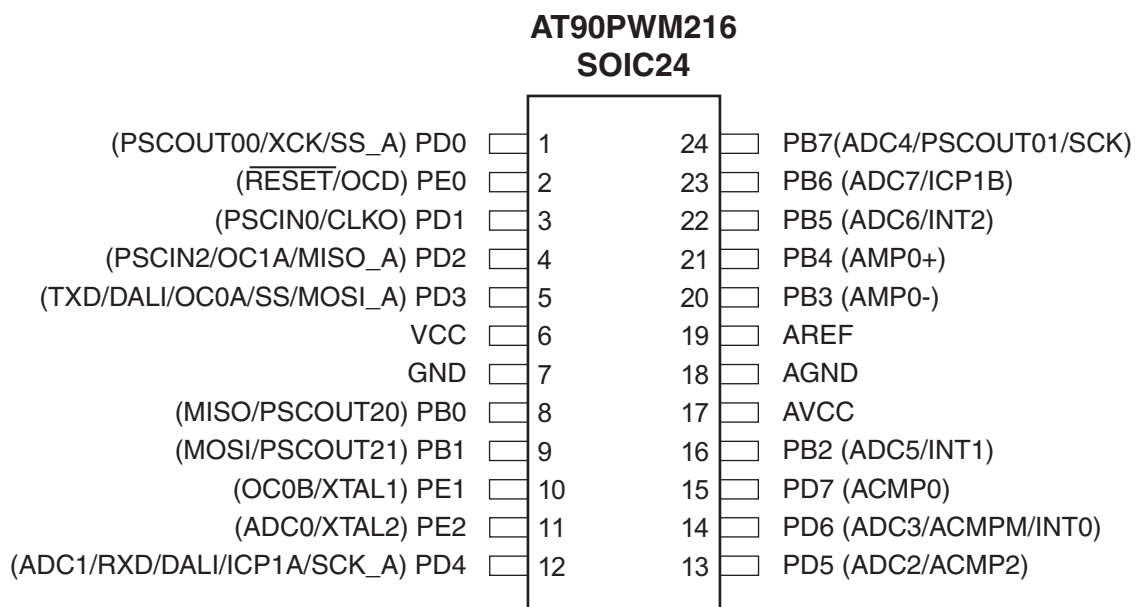

Figure 2-2. SOIC 32-pin Package

AT90PWM316
SOIC 32

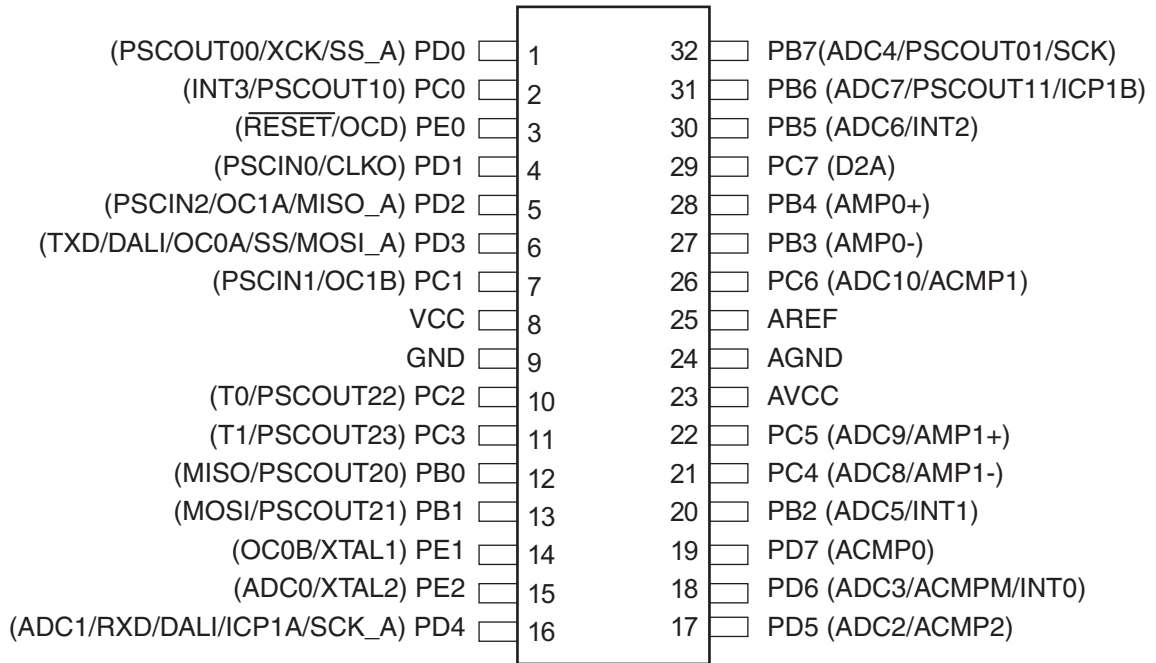
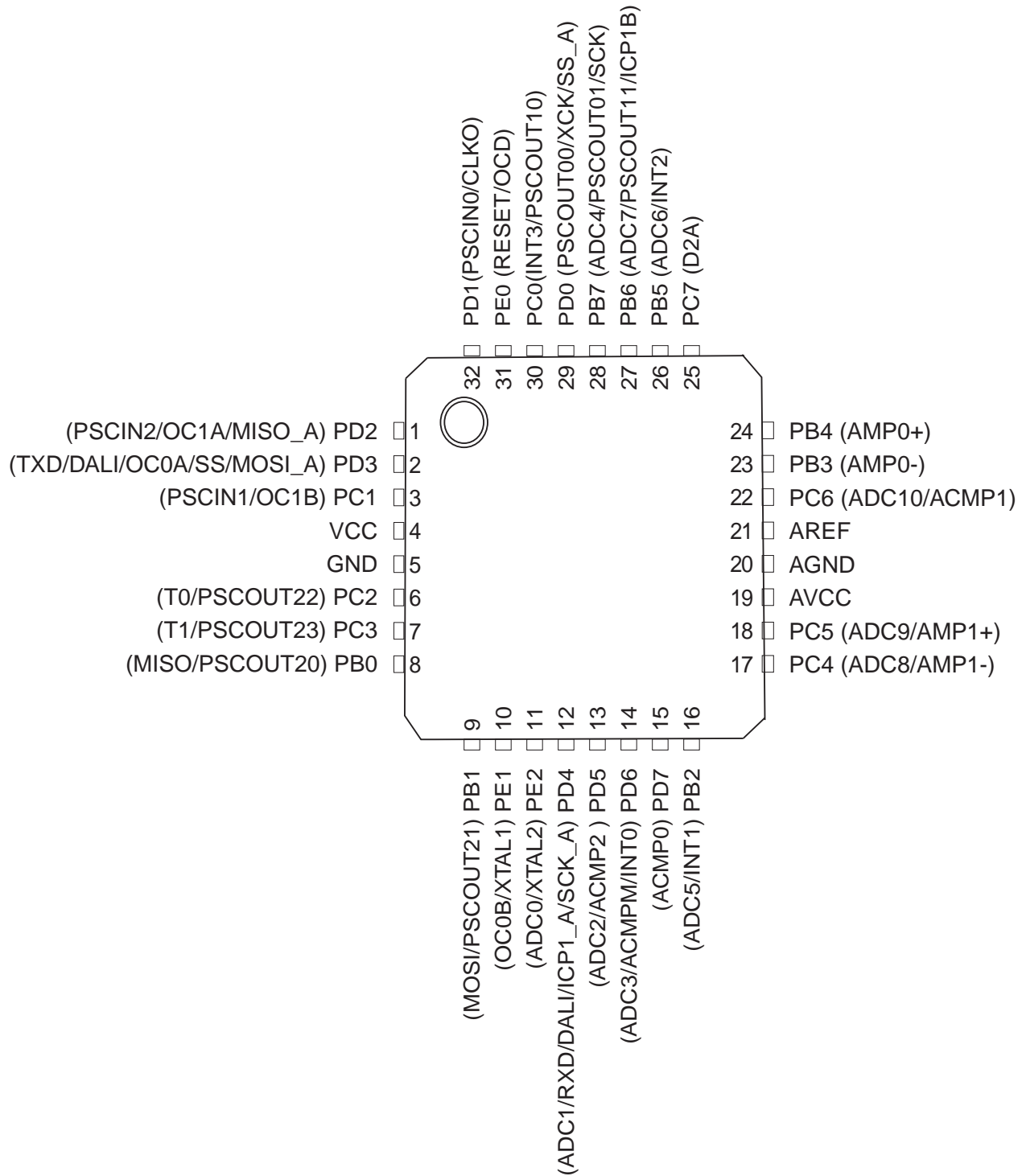

Figure 2-3. QFN32 (7*7 mm) Package.



Note: The Center GND PADDLE has to be connected to GND.

2.1 Pin Descriptions

Table 2-1. Pin out description

S024 Pin Number	SO32 Pin Number	QFN32 Pin Number	Mnemonic	Type	Name, Function & Alternate Function
7	9	5	GND	Power	Ground: 0V reference
18	24	20	AGND	Power	Analog Ground: 0V reference for analog part
6	8	4	VCC	power	Power Supply:
17	23	19	AVCC	Power	Analog Power Supply: This is the power supply voltage for analog part For a normal use this pin must be connected.
19	25	21	AREF	Power	Analog Reference: reference for analog converter. This is the reference voltage of the A/D converter. As output, can be used by external analog
8	12	8	PBO	I/O	MISO (SPI Master In Slave Out) PSCOUT20 output
9	13	9	PB1	I/O	MOSI (SPI Master Out Slave In) PSCOUT21 output
16	20	16	PB2	I/O	ADC5 (Analog Input Channel5) INT1
20	27	23	PB3	I/O	AMP0- (Analog Differential Amplifier 0 Input Channel)
21	28	24	PB4	I/O	AMP0+ (Analog Differential Amplifier 0 Input Channel)
22	30	26	PB5	I/O	ADC6 (Analog Input Channel 6) INT 2
23	31	27	PB6	I/O	ADC7 (Analog Input Channel 7) ICP1B (Timer 1 input capture alternate input) PSCOUT11 output (see note 1)
24	32	28	PB7	I/O	PSCOUT01 output ADC4 (Analog Input Channel 4) SCK (SPI Clock)
NA	2	30	PC0	I/O	PSCOUT10 output (see note 1) INT3
	7	3	PC1	I/O	PSCIN1 (PSC 1 Digital Input) OC1B (Timer 1 Output Compare B)
	10	6	PC2	I/O	T0 (Timer 0 clock input) PSCOUT22 output
	11	7	PC3	I/O	T1 (Timer 1 clock input) PSCOUT23 output
	21	17	PC4	I/O	ADC8 (Analog Input Channel 8) AMP1- (Analog Differential Amplifier 1 Input Channel)
	22	18	PC5	I/O	ADC9 (Analog Input Channel 9) AMP1+ (Analog Differential Amplifier 1 Input Channel)
	26	22	PC6	I/O	ADC10 (Analog Input Channel 10) ACMP1 (Analog Comparator 1 Positive Input)
29	25	PC7	I/O	D2A : DAC output ⁽²⁾	

Table 2-1. Pin out description (Continued)

S024 Pin Number	SO32 Pin Number	QFN32 Pin Number	Mnemonic	Type	Name, Function & Alternate Function
1	1	29	PD0	I/O	PSCOUT00 output ⁽¹⁾ XCK (UART Transfer Clock) SS_A (Alternate SPI Slave Select)
3	4	32	PD1	I/O	PSCIN0 (PSC 0 Digital Input) CLKO (System Clock Output)
4	5	1	PD2	I/O	PSCIN2 (PSC 2 Digital Input) OC1A (Timer 1 Output Compare A) MISO_A (Programming & alternate SPI Master In Slave Out)
5	6	2	PD3	I/O	TXD (Dali/UART Tx data) OC0A (Timer 0 Output Compare A) SS (SPI Slave Select) MOSI_A (Programming & alternate Master Out SPI Slave In)
12	16	12	PD4	I/O	ADC1 (Analog Input Channel 1) RXD (Dali/UART Rx data) ICP1A (Timer 1 input capture) SCK_A (Programming & alternate SPI Clock)
13	17	13	PD5	I/O	ADC2 (Analog Input Channel 2) ACMP2 (Analog Comparator 2 Positive Input)
14	18	14	PD6	I/O	ADC3 (Analog Input Channel 3) ACMPM reference for analog comparators INT0
15	19	15	PD7	I/O	ACMP0 (Analog Comparator 0 Positive Input)
2	3	31	PE0	I/O or I	RESET (Reset Input) OCD (On Chip Debug I/O)
10	14	10	PE1	I/O	XTAL1: XTAL Input OC0B (Timer 0 Output Compare B)
11	15	11	PE2	I/O	XTAL2: XTAL OuTput ADC0 (Analog Input Channel 0)

- Notes: 1. PSCOUT10 & PSCOUT11 are not present on 24 pins package
2. D2A (DAC Output) not available on AT90PWM261 (SOIC 24-pins)

3. Overview

The AT90PWM216/316 are low-power CMOS 8-bit microcontrollers based on the AVR enhanced RISC architecture. By executing powerful instructions in a single clock cycle, the AT90PWM216/316 achieves throughputs approaching 1 MIPS per MHz allowing the system designer to optimize power consumption versus processing speed.

3.1 Block Diagram

Figure 3-1. Block Diagram

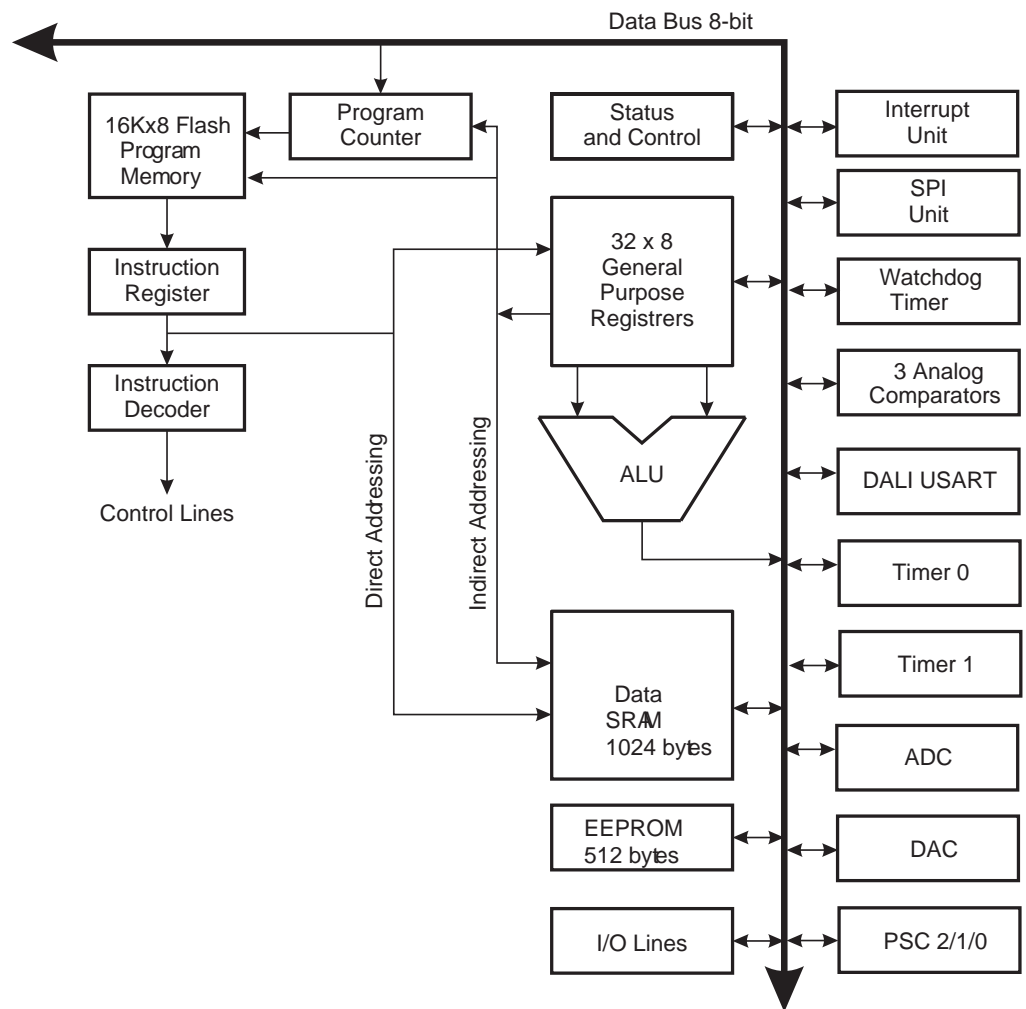

The AVR core combines a rich instruction set with 32 general purpose working registers. All the 32 registers are directly connected to the Arithmetic Logic Unit (ALU), allowing two independent registers to be accessed in one single instruction executed in one clock cycle. The resulting architecture is more code efficient while achieving throughputs up to ten times faster than conventional CISC microcontrollers.

The AT90PWM216/316 provides the following features: 16K bytes of In-System Programmable Flash with Read-While-Write capabilities, 512 bytes EEPROM, 1024 bytes SRAM, 53 general purpose I/O lines, 32 general purpose working registers, three Power Stage Controllers, two flexible Timer/Counters with compare modes and PWM, one USART with DALI mode, an 11-channel 10-bit ADC with two differential input stage with programmable gain, a 10-bit DAC, a programmable Watchdog Timer with Internal Oscillator, an SPI serial port, an On-chip Debug system and four software selectable power saving modes.

The Idle mode stops the CPU while allowing the SRAM, Timer/Counters, SPI ports and interrupt system to continue functioning. The Power-down mode saves the register contents but freezes the Oscillator, disabling all other chip functions until the next interrupt or Hardware Reset. The ADC Noise Reduction mode stops the CPU and all I/O modules except ADC, to minimize switching noise during ADC conversions. In Standby mode, the Crystal/Res-

onator Oscillator is running while the rest of the device is sleeping. This allows very fast start-up combined with low power consumption.

The device is manufactured using the Atmel high-density nonvolatile memory technology. The On-chip ISP Flash allows the program memory to be reprogrammed in-system through an SPI serial interface, by a conventional non-volatile memory programmer, or by an On-chip Boot program running on the AVR core. The boot program can use any interface to download the application program in the application Flash memory. Software in the Boot Flash section will continue to run while the Application Flash section is updated, providing true Read-While-Write operation. By combining an 8-bit RISC CPU with In-System Self-Programmable Flash on a monolithic chip, the Atmel AT90PWM216/316 is a powerful microcontroller that provides a highly flexible and cost effective solution to many embedded control applications.

The AT90PWM216/316 AVR is supported with a full suite of program and system development tools including: C compilers, macro assemblers, program debugger/simulators, in-circuit emulators, and evaluation kits.

Note: AT90PWM216 device is available in SOIC 24-pin Package and does not have the D2A (DAC Output) brought out to I/O pins.

3.2 Pin Descriptions

3.2.1 VCC

Digital supply voltage.

3.2.2 GND

Ground.

3.2.3 Port B (PB7..PB0)

Port B is an 8-bit bi-directional I/O port with internal pull-up resistors (selected for each bit). The Port B output buffers have symmetrical drive characteristics with both high sink and source capability. As inputs, Port B pins that are externally pulled low will source current if the pull-up resistors are activated. The Port B pins are tri-stated when a reset condition becomes active, even if the clock is not running.

Port B also serves the functions of various special features of the AT90PWM216/316 as listed on [page 63](#).

3.2.4 Port C (PC7..PC0)

Port C is an 8-bit bi-directional I/O port with internal pull-up resistors (selected for each bit). The Port C output buffers have symmetrical drive characteristics with both high sink and source capability. As inputs, Port C pins that are externally pulled low will source current if the pull-up resistors are activated. The Port C pins are tri-stated when a reset condition becomes active, even if the clock is not running.

Port C is not available on 24 pins package.

Port C also serves the functions of special features of the AT90PWM316 as listed on [page 65](#).

3.2.5 Port D (PD7..PD0)

Port D is an 8-bit bi-directional I/O port with internal pull-up resistors (selected for each bit). The Port D output buffers have symmetrical drive characteristics with both high sink and source capability. As inputs, Port D pins that are externally pulled low will source current if the pull-up resistors are activated. The Port D pins are tri-stated when a reset condition becomes active, even if the clock is not running.

Port D also serves the functions of various special features of the AT90PWM216/316 as listed on [page 68](#).

3.2.6 **Port E (PE2..0) RESET/ XTAL1/ XTAL2**

Port E is an 3-bit bi-directional I/O port with internal pull-up resistors (selected for each bit). The Port E output buffers have symmetrical drive characteristics with both high sink and source capability. As inputs, Port E pins that are externally pulled low will source current if the pull-up resistors are activated. The Port E pins are tri-stated when a reset condition becomes active, even if the clock is not running.

If the RSTDISBL Fuse is programmed, PE0 is used as an I/O pin. Note that the electrical characteristics of PE0 differ from those of the other pins of Port C.

If the RSTDISBL Fuse is unprogrammed, PE0 is used as a Reset input. A low level on this pin for longer than the minimum pulse length will generate a Reset, even if the clock is not running. The minimum pulse length is given in [Table 8-1 on page 41](#). Shorter pulses are not guaranteed to generate a Reset.

Depending on the clock selection fuse settings, PE1 can be used as input to the inverting Oscillator amplifier and input to the internal clock operating circuit.

Depending on the clock selection fuse settings, PE2 can be used as output from the inverting Oscillator amplifier.

The various special features of Port E are elaborated in [“Alternate Functions of Port E” on page 71](#) and [“Clock Systems and their Distribution” on page 25](#).

3.2.7 **AVCC**

AVCC is the supply voltage pin for the A/D Converter. It should be externally connected to V_{CC} , even if the ADC is not used. If the ADC is used, it should be connected to V_{CC} through a low-pass filter.

3.2.8 **AREF**

This is the analog reference pin for the A/D Converter.

3.3 **About Code Examples**

This documentation contains simple code examples that briefly show how to use various parts of the device. These code examples assume that the part specific header file is included before compilation. Be aware that not all C compiler vendors include bit definitions in the header files and interrupt handling in C is compiler dependent. Please confirm with the C compiler documentation for more details.

4. Register Summary

Address	Name	Bit 7	Bit 6	Bit 5	Bit 4	Bit 3	Bit 2	Bit 1	Bit 0	Page
(0xFF)	PICR2H									page 161
(0xFE)	PICR2L									page 161
(0xFD)	PFRC2B	PCAE2B	PISEL2B	PELEV2B	PFLTE2B	PRFM2B3	PRFM2B2	PRFM2B1	PRFM2B0	page 160
(0xFC)	PFRC2A	PCAE2A	PISEL2A	PELEV2A	PFLTE2A	PRFM2A3	PRFM2A2	PRFM2A1	PRFM2A0	page 159
(0xFB)	PCTL2	PPRE21	PPRE20	PBFM2	PAOC2B	PAOC2A	PARUN2	PCCYC2	PRUN2	page 159
(0xFA)	PCNF2	PFIFTY2	PALOCK2	PLOCK2	PMODE21	PMODE20	POP2	PCLKSEL2	POME2	page 156
(0xF9)	OCR2RBH									page 155
(0xF8)	OCR2RBL									page 155
(0xF7)	OCR2SBH									page 155
(0xF6)	OCR2SBL									page 155
(0xF5)	OCR2RAH									page 155
(0xF4)	OCR2RAL									page 155
(0xF3)	OCR2SAH									page 155
(0xF2)	OCR2SAL									page 155
(0xF1)	POM2	POMV2B3	POMV2B2	POMV2B1	POMV2B0	POMV2A3	POMV2A2	POMV2A1	POMV2A0	page 162
(0xF0)	PSOC2	POS23	POS22	PSYNC21	PSYNC20	POEN2D	POEN2B	POEN2C	POEN2A	page 154
(0xEF)	PICR1H									page 161
(0xEE)	PICR1L									page 161
(0xED)	PFRC1B	PCAE1B	PISEL1B	PELEV1B	PFLTE1B	PRFM1B3	PRFM1B2	PRFM1B1	PRFM1B0	page 160
(0xEC)	PFRC1A	PCAE1A	PISEL1A	PELEV1A	PFLTE1A	PRFM1A3	PRFM1A2	PRFM1A1	PRFM1A0	page 159
(0xEB)	PCTL1	PPRE11	PPRE10	PBFM1	PAOC1B	PAOC1A	PARUN1	PCCYC1	PRUN1	page 158
(0xEA)	PCNF1	PFIFTY1	PALOCK1	PLOCK1	PMODE11	PMODE10	POP1	PCLKSEL1	-	page 156
(0xE9)	OCR1RBH									page 155
(0xE8)	OCR1RBL									page 155
(0xE7)	OCR1SBH									page 155
(0xE6)	OCR1SBL									page 155
(0xE5)	OCR1RAH									page 155
(0xE4)	OCR1RAL									page 155
(0xE3)	OCR1SAH									page 155
(0xE2)	OCR1SAL									page 155
(0xE1)	Reserved	-	-	-	-	-	-	-	-	
(0xE0)	PSOC1	-	-	PSYNC11	PSYNC10	-	POEN1B	-	POEN1A	page 153
(0xDF)	PICR0H									page 161
(0xDE)	PICR0L									page 161
(0xDD)	PFRC0B	PCAE0B	PISEL0B	PELEV0B	PFLTE0B	PRFM0B3	PRFM0B2	PRFM0B1	PRFM0B0	page 160
(0xDC)	PFRC0A	PCAE0A	PISEL0A	PELEV0A	PFLTE0A	PRFM0A3	PRFM0A2	PRFM0A1	PRFM0A0	page 159
(0xDB)	PCTL0	PPRE01	PPRE00	PBFM0	PAOC0B	PAOC0A	PARUN0	PCCYC0	PRUN0	page 157
(0xDA)	PCNF0	PFIFTY0	PALOCK0	PLOCK0	PMODE01	PMODE00	POP0	PCLKSEL0	-	page 155
(0xD9)	OCR0RBH									page 155
(0xD8)	OCR0RBL									page 155
(0xD7)	OCR0SBH									page 155
(0xD6)	OCR0SBL									page 155
(0xD5)	OCR0RAH									page 155
(0xD4)	OCR0RAL									page 155
(0xD3)	OCR0SAH									page 155
(0xD2)	OCR0SAL									page 155
(0xD1)	Reserved	-	-	-	-	-	-	-	-	
(0xD0)	PSOC0	-	-	PSYNC01	PSYNC00	-	POEN0B	-	POEN0A	page 153
(0xCF)	Reserved	-	-	-	-	-	-	-	-	
(0xCE)	EUDR	EUDR7	EUDR6	EUDR5	EUDR4	EUDR3	EUDR2	EUDR1	EUDR0	page 209
(0xCD)	MUBRRH	MUBRR15	MUBRR014	MUBRR13	MUBRR12	MUBRR011	MUBRR010	MUBRR9	MUBRR8	page 214
(0xCC)	MUBRRL	MUBRR7	MUBRR6	MUBRR5	MUBRR4	MUBRR3	MUBRR2	MUBRR1	MUBRR0	page 214
(0xCB)	Reserved	-	-	-	-	-	-	-	-	
(0xCA)	EUCSRC	-	-	-	-	FEM	F1617	STP1	STP0	page 213
(0xC9)	EUCSRB	-	-	-	EUSART	EUSBS	-	EMCH	BODR	page 212
(0xC8)	EUCSRA	UTxS3	UTxS2	UTxS1	UTxS0	URxS3	URxS2	URxS1	URxS0	page 211
(0xC7)	Reserved	-	-	-	-	-	-	-	-	
(0xC6)	UDR	UDR07	UDR06	UDR05	UDR04	UDR03	UDR02	UDR01	UDR00	page 209 & page 191
(0xC5)	UBRRH	-	-	-	-	UBRR011	UBRR010	UBRR09	UBRR08	page 195
(0xC4)	UBRRL	UBRR07	UBRR06	UBRR05	UBRR04	UBRR03	UBRR02	UBRR01	UBRR00	page 195
(0xC3)	Reserved	-	-	-	-	-	-	-	-	
(0xC2)	UCSRC	-	UMSEL0	UPM01	UPM00	USBS0	UCSZ01	UCSZ00	UCPOL0	page 194
(0xC1)	UCSRB	RXCIE0	TXCIE0	UDRIE0	RXEN0	TXEN0	UCSZ02	RXB80	TXB80	page 193
(0xC0)	UCSRA	RXC0	TXC0	UDRE0	FE0	DOR0	UPE0	U2X0	MPCM0	page 191
(0xBF)	Reserved	-	-	-	-	-	-	-	-	
(0xBE)	Reserved	-	-	-	-	-	-	-	-	

Address	Name	Bit 7	Bit 6	Bit 5	Bit 4	Bit 3	Bit 2	Bit 1	Bit 0	Page
(0xBD)	Reserved	-	-	-	-	-	-	-	-	
(0xBC)	Reserved	-	-	-	-	-	-	-	-	
(0xBB)	Reserved	-	-	-	-	-	-	-	-	
(0xBA)	Reserved	-	-	-	-	-	-	-	-	
(0xB9)	Reserved	-	-	-	-	-	-	-	-	
(0xB8)	Reserved	-	-	-	-	-	-	-	-	
(0xB7)	Reserved	-	-	-	-	-	-	-	-	
(0xB6)	Reserved	-	-	-	-	-	-	-	-	
(0xB5)	Reserved	-	-	-	-	-	-	-	-	
(0xB4)	Reserved	-	-	-	-	-	-	-	-	
(0xB3)	Reserved	-	-	-	-	-	-	-	-	
(0xB2)	Reserved	-	-	-	-	-	-	-	-	
(0xB1)	Reserved	-	-	-	-	-	-	-	-	
(0xB0)	Reserved	-	-	-	-	-	-	-	-	
(0xAF)	AC2CON	AC2EN	AC2IE	AC2IS1	AC2IS0	-	AC2M2	AC2M1	AC2M0	page 218
(0xAE)	AC1CON	AC1EN	AC1IE	AC1IS1	AC1IS0	AC1ICE	AC1M2	AC1M1	AC1M0	page 217
(0xAD)	AC0CON	AC0EN	AC0IE	AC0IS1	AC0IS0	-	AC0M2	AC0M1	AC0M0	page 216
(0xAC)	DACH	- / DAC9	- / DAC8	- / DAC7	- / DAC6	- / DAC5	- / DAC4	DAC9 / DAC3	DAC8 / DAC2	page 247
(0xAB)	DAACL	DAC7 / DAC1	DAC6 / DAC0	DAC5 / -	DAC4 / -	DAC3 / -	DAC2 / -	DAC1 / -	DAC0 /	page 247
(0xAA)	DACON	DAATE	DATS2	DATS1	DATS0	-	DALA	DAOE	DAEN	page 246
(0xA9)	Reserved	-	-	-	-	-	-	-	-	
(0xA8)	Reserved	-	-	-	-	-	-	-	-	
(0xA7)	Reserved	-	-	-	-	-	-	-	-	
(0xA6)	Reserved	-	-	-	-	-	-	-	-	
(0xA5)	PIM2	-	-	PSEIE2	PEVE2B	PEVE2A	-	-	PEOPE2	page 162
(0xA4)	PIFR2	-	-	PSEIE1	PEVE2B	PEVE2A	PRN21	PRN20	PEOP2	page 163
(0xA3)	PIM1	-	-	PSEIE1	PEVE1B	PEVE1A	-	-	PEOPE1	page 162
(0xA2)	PIFR1	-	-	PSEIE1	PEVE1B	PEVE1A	PRN11	PRN10	PEOP1	page 163
(0xA1)	PIM0	-	-	PSEIE0	PEVE0B	PEVE0A	-	-	PEOPE0	page 162
(0xA0)	PIFR0	-	-	PSEIE0	PEVE0B	PEVE0A	PRN01	PRN00	PEOP0	page 163
(0x9F)	Reserved	-	-	-	-	-	-	-	-	
(0x9E)	Reserved	-	-	-	-	-	-	-	-	
(0x9D)	Reserved	-	-	-	-	-	-	-	-	
(0x9C)	Reserved	-	-	-	-	-	-	-	-	
(0x9B)	Reserved	-	-	-	-	-	-	-	-	
(0x9A)	Reserved	-	-	-	-	-	-	-	-	
(0x99)	Reserved	-	-	-	-	-	-	-	-	
(0x98)	Reserved	-	-	-	-	-	-	-	-	
(0x97)	Reserved	-	-	-	-	-	-	-	-	
(0x96)	Reserved	-	-	-	-	-	-	-	-	
(0x95)	Reserved	-	-	-	-	-	-	-	-	
(0x94)	Reserved	-	-	-	-	-	-	-	-	
(0x93)	Reserved	-	-	-	-	-	-	-	-	
(0x92)	Reserved	-	-	-	-	-	-	-	-	
(0x91)	Reserved	-	-	-	-	-	-	-	-	
(0x90)	Reserved	-	-	-	-	-	-	-	-	
(0x8F)	Reserved	-	-	-	-	-	-	-	-	
(0x8E)	Reserved	-	-	-	-	-	-	-	-	
(0x8D)	Reserved	-	-	-	-	-	-	-	-	
(0x8C)	Reserved	-	-	-	-	-	-	-	-	
(0x8B)	OCR1BH	OCR1B15	OCR1B14	OCR1B13	OCR1B12	OCR1B11	OCR1B10	OCR1B9	OCR1B8	page 119
(0x8A)	OCR1BL	OCR1B7	OCR1B6	OCR1B5	OCR1B4	OCR1B3	OCR1B2	OCR1B1	OCR1B0	page 119
(0x89)	OCR1AH	OCR1A15	OCR1A14	OCR1A13	OCR1A12	OCR1A11	OCR1A10	OCR1A9	OCR1A8	page 119
(0x88)	OCR1AL	OCR1A7	OCR1A6	OCR1A5	OCR1A4	OCR1A3	OCR1A2	OCR1A1	OCR1A0	page 119
(0x87)	ICR1H	ICR115	ICR114	ICR113	ICR112	ICR111	ICR110	ICR19	ICR18	page 119
(0x86)	ICR1L	ICR17	ICR16	ICR15	ICR14	ICR13	ICR12	ICR11	ICR10	page 119
(0x85)	TCNT1H	TCNT115	TCNT114	TCNT113	TCNT112	TCNT111	TCNT110	TCNT19	TCNT18	page 119
(0x84)	TCNT1L	TCNT17	TCNT16	TCNT15	TCNT14	TCNT13	TCNT12	TCNT11	TCNT10	page 119
(0x83)	Reserved	-	-	-	-	-	-	-	-	
(0x82)	TCCR1C	FOC1A	FOC1B	-	-	-	-	-	-	page 118
(0x81)	TCCR1B	ICNC1	ICES1	-	WGM13	WGM12	CS12	CS11	CS10	page 117
(0x80)	TCCR1A	COM1A1	COM1A0	COM1B1	COM1B0	-	-	WGM11	WGM10	page 114
(0x7F)	DIDR1	-	-	ACMP0D	AMP0PD	AMP0ND	ADC10D/ACMP1D	ADC9D/AMP1PD	ADC8D/AMP1ND	page 239
(0x7E)	DIDR0	ADC7D	ADC6D	ADC5D	ADC4D	ADC3D/ACMPMD	ADC2D/ACMP2D	ADC1D	ADC0D	page 239
(0x7D)	Reserved	-	-	-	-	-	-	-	-	
(0x7C)	ADMUX	REFS1	REFS0	ADLAR	-	MUX3	MUX2	MUX1	MUX0	page 235
(0x7B)	ADCSRB	ADHSM	-	-	-	ADTS3	ADTS2	ADTS1	ADTS0	page 237
(0x7A)	ADCSRA	ADEN	ADSC	ADATE	ADIF	ADIE	ADPS2	ADPS1	ADPS0	page 236

Address	Name	Bit 7	Bit 6	Bit 5	Bit 4	Bit 3	Bit 2	Bit 1	Bit 0	Page	
(0x79)	ADCH	- / ADC9	- / ADC8	- / ADC7	- / ADC6	- / ADC5	- / ADC4	ADC9 / ADC3	ADC8 / ADC2	page 238	
(0x78)	ADCL	ADC7 / ADC1	ADC6 / ADC0	ADC5 / -	ADC4 / -	ADC3 / -	ADC2 / -	ADC1 / -	ADC0 / -	page 238	
(0x77)	AMP1CSR	AMP1EN	-	AMP1G1	AMP1G0	-	AMP1TS1	AMP1TS1	AMP1TS0	page 244	
(0x76)	AMP0CSR	AMP0EN	-	AMP0G1	AMP0G0	-	AMP0TS2	AMP0TS1	AMP0TS0	page 243	
(0x75)	Reserved	-	-	-	-	-	-	-	-		
(0x74)	Reserved	-	-	-	-	-	-	-	-		
(0x73)	Reserved	-	-	-	-	-	-	-	-		
(0x72)	Reserved	-	-	-	-	-	-	-	-		
(0x71)	Reserved	-	-	-	-	-	-	-	-		
(0x70)	Reserved	-	-	-	-	-	-	-	-		
(0x6F)	TIMSK1	-	-	ICIE1	-	-	OCIE1B	OCIE1A	TOIE1	page 120	
(0x6E)	TIMSK0	-	-	-	-	-	OCIE0B	OCIE0A	TOIE0	page 93	
(0x6D)	Reserved	-	-	-	-	-	-	-	-		
(0x6C)	Reserved	-	-	-	-	-	-	-	-		
(0x6B)	Reserved	-	-	-	-	-	-	-	-		
(0x6A)	Reserved	-	-	-	-	-	-	-	-		
(0x69)	EICRA	ISC31	ISC30	ISC21	ISC20	ISC11	ISC10	ISC01	ISC00	page 75	
(0x68)	Reserved	-	-	-	-	-	-	-	-		
(0x67)	Reserved	-	-	-	-	-	-	-	-		
(0x66)	OSCCAL	-	CAL6	CAL5	CAL4	CAL3	CAL2	CAL1	CAL0	page 29	
(0x65)	Reserved	-	-	-	-	-	-	-	-		
(0x64)	PRR	PRPSC2	PRPSC1	PRPSC0	PRTIM1	PRTIM0	PRSPI	PRUSART	PRADC	page 37	
(0x63)	Reserved	-	-	-	-	-	-	-	-		
(0x62)	Reserved	-	-	-	-	-	-	-	-		
(0x61)	CLKPR	CLKPCE	-	-	-	CLKPS3	CLKPS2	CLKPS1	CLKPS0	page 33	
(0x60)	WDTCSR	WDIF	WDIE	WDP3	WDCE	WDE	WDP2	WDP1	WDP0	page 48	
0x3F (0x5F)	SREG	I	T	H	S	V	N	Z	C	page 11	
0x3E (0x5E)	SPH	SP15	SP14	SP13	SP12	SP11	SP10	SP9	SP8	page 14	
0x3D (0x5D)	SPL	SP7	SP6	SP5	SP4	SP3	SP2	SP1	SP0	page 14	
0x3C (0x5C)	Reserved	-	-	-	-	-	-	-	-		
0x3B (0x5B)	Reserved	-	-	-	-	-	-	-	-		
0x3A (0x5A)	Reserved	-	-	-	-	-	-	-	-		
0x39 (0x59)	Reserved	-	-	-	-	-	-	-	-		
0x38 (0x58)	Reserved	-	-	-	-	-	-	-	-		
0x37 (0x57)	SPMCSR	SPMIE	RWWWSB	-	RWWWSRE	BLBSET	PGWRT	PGERS	SPMEN	page 256	
0x36 (0x56)	Reserved	-	-	-	-	-	-	-	-		
0x35 (0x55)	MCUCR	SPIPS	-	-	PUD	-	-	IVSEL	IVCE	page 54 & page 62	
0x34 (0x54)	MCUSR	-	-	-	-	WDRF	BORF	EXTRF	PORF	page 44	
0x33 (0x53)	SMCR	-	-	-	-	SM2	SM1	SM0	SE	page 35	
0x32 (0x52)	MSMCR	Monitor Stop Mode Control Register								reserved	
0x31 (0x51)	MONDR	Monitor Data Register								reserved	
0x30 (0x50)	ACSR	-	AC2IF	AC1IF	AC0IF	-	-	AC2O	AC1O	AC0O	page 219
0x2F (0x4F)	Reserved	-	-	-	-	-	-	-	-		
0x2E (0x4E)	SPDR	SPD7	SPD6	SPD5	SPD4	SPD3	SPD2	SPD1	SPD0	page 171	
0x2D (0x4D)	SPSR	SPIF	WCOL	-	-	-	-	-	SPI2X	page 171	
0x2C (0x4C)	SPCR	SPIE	SPE	DORD	MSTR	CPOL	CPHA	SPR1	SPR0	page 169	
0x2B (0x4B)	Reserved	-	-	-	-	-	-	-	-		
0x2A (0x4A)	Reserved	-	-	-	-	-	-	-	-		
0x29 (0x49)	PLLCSR	-	-	-	-	-	PLLF	PLLE	PLOCK	page 31	
0x28 (0x48)	OCR0B	OCR0B7	OCR0B6	OCR0B5	OCR0B4	OCR0B3	OCR0B2	OCR0B1	OCR0B0	page 93	
0x27 (0x47)	OCR0A	OCR0A7	OCR0A6	OCR0A5	OCR0A4	OCR0A3	OCR0A2	OCR0A1	OCR0A0	page 93	
0x26 (0x46)	TCNT0	TCNT07	TCNT06	TCNT05	TCNT04	TCNT03	TCNT02	TCNT01	TCNT00	page 93	
0x25 (0x45)	TCCR0B	FOC0A	FOC0B	-	-	WGM02	CS02	CS01	CS00	page 91	
0x24 (0x44)	TCCR0A	COM0A1	COM0A0	COM0B1	COM0B0	-	-	WGM01	WGM00	page 89	
0x23 (0x43)	GTCCR	TSM	ICPSEL1	-	-	-	-	-	PSRSYNC	page 78	
0x22 (0x42)	EEARH	-	-	-	-	EEAR11	EEAR10	EEAR9	EEAR8	page 19	
0x21 (0x41)	EEARL	EEAR7	EEAR6	EEAR5	EEAR4	EEAR3	EEAR2	EEAR1	EEAR0	page 19	
0x20 (0x40)	EEDR	EEDR7	EEDR6	EEDR5	EEDR4	EEDR3	EEDR2	EEDR1	EEDR0	page 19	
0x1F (0x3F)	EECR	-	-	-	-	EERIE	EEMWE	EEWE	EERE	page 20	
0x1E (0x3E)	GPOR0	GPOR07	GPOR06	GPOR05	GPOR04	GPOR03	GPOR02	GPOR01	GPOR00	page 24	
0x1D (0x3D)	EIMSK	-	-	-	-	INT3	INT2	INT1	INT0	page 76	
0x1C (0x3C)	EIFR	-	-	-	-	INTF3	INTF2	INTF1	INTF0	page 76	
0x1B (0x3B)	GPOR3	GPOR37	GPOR36	GPOR35	GPOR34	GPOR33	GPOR32	GPOR31	GPOR30	page 24	
0x1A (0x3A)	GPOR2	GPOR27	GPOR26	GPOR25	GPOR24	GPOR23	GPOR22	GPOR21	GPOR20	page 24	
0x19 (0x39)	GPOR1	GPOR17	GPOR16	GPOR15	GPOR14	GPOR13	GPOR12	GPOR11	GPOR10	page 24	
0x18 (0x38)	Reserved	-	-	-	-	-	-	-	-		
0x17 (0x37)	Reserved	-	-	-	-	-	-	-	-		
0x16 (0x36)	TIFR1	-	-	ICF1	-	-	OCF1B	OCF1A	TOV1	page 120	

Address	Name	Bit 7	Bit 6	Bit 5	Bit 4	Bit 3	Bit 2	Bit 1	Bit 0	Page
0x15 (0x35)	TIFR0	–	–	–	–	–	OCF0B	OCF0A	TOV0	page 94
0x14 (0x34)	Reserved	–	–	–	–	–	–	–	–	
0x13 (0x33)	Reserved	–	–	–	–	–	–	–	–	
0x12 (0x32)	Reserved	–	–	–	–	–	–	–	–	
0x11 (0x31)	Reserved	–	–	–	–	–	–	–	–	
0x10 (0x30)	Reserved	–	–	–	–	–	–	–	–	
0x0F (0x2F)	Reserved	–	–	–	–	–	–	–	–	
0x0E (0x2E)	PORTE	–	–	–	–	–	PORTE2	PORTE1	PORTE0	page 74
0x0D (0x2D)	DDRE	–	–	–	–	–	DDE2	DDE1	DDE0	page 74
0x0C (0x2C)	PINE	–	–	–	–	–	PINE2	PINE1	PINE0	page 74
0x0B (0x2B)	PORTD	PORTD7	PORTD6	PORTD5	PORTD4	PORTD3	PORTD2	PORTD1	PORTD0	page 73
0x0A (0x2A)	DDRD	DDD7	DDD6	DDD5	DDD4	DDD3	DDD2	DDD1	DDD0	page 73
0x09 (0x29)	PIND	PIND7	PIND6	PIND5	PIND4	PIND3	PIND2	PIND1	PIND0	page 74
0x08 (0x28)	PORTC	PORTC7	PORTC6	PORTC5	PORTC4	PORTC3	PORTC2	PORTC1	PORTC0	page 73
0x07 (0x27)	DDRC	DDC7	DDC6	DDC5	DDC4	DDC3	DDC2	DDC1	DDC0	page 73
0x06 (0x26)	PINC	PINC7	PINC6	PINC5	PINC4	PINC3	PINC2	PINC1	PINC0	page 73
0x05 (0x25)	PORTB	PORTB7	PORTB6	PORTB5	PORTB4	PORTB3	PORTB2	PORTB1	PORTB0	page 73
0x04 (0x24)	DDRB	DDB7	DDB6	DDB5	DDB4	DDB3	DDB2	DDB1	DDB0	page 73
0x03 (0x23)	PINB	PINB7	PINB6	PINB5	PINB4	PINB3	PINB2	PINB1	PINB0	page 73
0x02 (0x22)	Reserved	–	–	–	–	–	–	–	–	
0x01 (0x21)	Reserved	–	–	–	–	–	–	–	–	
0x00 (0x20)	Reserved	–	–	–	–	–	–	–	–	

- Note:
1. For compatibility with future devices, reserved bits should be written to zero if accessed. Reserved I/O memory addresses should never be written.
 2. I/O Registers within the address range 0x00 - 0x1F are directly bit-accessible using the SBI and CBI instructions. In these registers, the value of single bits can be checked by using the SBIS and SBIC instructions.
 3. Some of the status flags are cleared by writing a logical one to them. Note that, unlike most other AVR, the CBI and SBI instructions will only operate on the specified bit, and can therefore be used on registers containing such status flags. The CBI and SBI instructions work with registers 0x00 to 0x1F only.
 4. When using the I/O specific commands IN and OUT, the I/O addresses 0x00 - 0x3F must be used. When addressing I/O Registers as data space using LD and ST instructions, 0x20 must be added to these addresses. The AT90PWM216/316 is a complex microcontroller with more peripheral units than can be supported within the 64 location reserved in Opcode for the IN and OUT instructions. For the Extended I/O space from 0x60 - 0xFF in SRAM, only the ST/STS/STD and LD/LDS/LDD instructions can be used.

5. Instruction Set Summary

Mnemonics	Operands	Description	Operation	Flags	#Clocks
ARITHMETIC AND LOGIC INSTRUCTIONS					
ADD	Rd, Rr	Add two Registers	$Rd \leftarrow Rd + Rr$	Z,C,N,V,H	1
ADC	Rd, Rr	Add with Carry two Registers	$Rd \leftarrow Rd + Rr + C$	Z,C,N,V,H	1
ADIW	RdI,K	Add Immediate to Word	$Rdh:Rdl \leftarrow Rdh:Rdl + K$	Z,C,N,V,S	2
SUB	Rd, Rr	Subtract two Registers	$Rd \leftarrow Rd - Rr$	Z,C,N,V,H	1
SUBI	Rd, K	Subtract Constant from Register	$Rd \leftarrow Rd - K$	Z,C,N,V,H	1
SBC	Rd, Rr	Subtract with Carry two Registers	$Rd \leftarrow Rd - Rr - C$	Z,C,N,V,H	1
SBCI	Rd, K	Subtract with Carry Constant from Reg.	$Rd \leftarrow Rd - K - C$	Z,C,N,V,H	1
SBIW	RdI,K	Subtract Immediate from Word	$Rdh:Rdl \leftarrow Rdh:Rdl - K$	Z,C,N,V,S	2
AND	Rd, Rr	Logical AND Registers	$Rd \leftarrow Rd \cdot Rr$	Z,N,V	1
ANDI	Rd, K	Logical AND Register and Constant	$Rd \leftarrow Rd \cdot K$	Z,N,V	1
OR	Rd, Rr	Logical OR Registers	$Rd \leftarrow Rd \vee Rr$	Z,N,V	1
ORI	Rd, K	Logical OR Register and Constant	$Rd \leftarrow Rd \vee K$	Z,N,V	1
EOR	Rd, Rr	Exclusive OR Registers	$Rd \leftarrow Rd \oplus Rr$	Z,N,V	1
COM	Rd	One's Complement	$Rd \leftarrow 0xFF - Rd$	Z,C,N,V	1
NEG	Rd	Two's Complement	$Rd \leftarrow 0x00 - Rd$	Z,C,N,V,H	1
SBR	Rd,K	Set Bit(s) in Register	$Rd \leftarrow Rd \vee K$	Z,N,V	1
CBR	Rd,K	Clear Bit(s) in Register	$Rd \leftarrow Rd \cdot (0xFF - K)$	Z,N,V	1
INC	Rd	Increment	$Rd \leftarrow Rd + 1$	Z,N,V	1
DEC	Rd	Decrement	$Rd \leftarrow Rd - 1$	Z,N,V	1
TST	Rd	Test for Zero or Minus	$Rd \leftarrow Rd \cdot Rd$	Z,N,V	1
CLR	Rd	Clear Register	$Rd \leftarrow Rd \oplus Rd$	Z,N,V	1
SER	Rd	Set Register	$Rd \leftarrow 0xFF$	None	1
MUL	Rd, Rr	Multiply Unsigned	$R1:R0 \leftarrow Rd \times Rr$	Z,C	2
MULS	Rd, Rr	Multiply Signed	$R1:R0 \leftarrow Rd \times Rr$	Z,C	2
MULSU	Rd, Rr	Multiply Signed with Unsigned	$R1:R0 \leftarrow Rd \times Rr$	Z,C	2
FMUL	Rd, Rr	Fractional Multiply Unsigned	$R1:R0 \leftarrow (Rd \times Rr) \ll 1$	Z,C	2
FMULS	Rd, Rr	Fractional Multiply Signed	$R1:R0 \leftarrow (Rd \times Rr) \ll 1$	Z,C	2
FMULSU	Rd, Rr	Fractional Multiply Signed with Unsigned	$R1:R0 \leftarrow (Rd \times Rr) \ll 1$	Z,C	2
BRANCH INSTRUCTIONS					
RJMP	k	Relative Jump	$PC \leftarrow PC + k + 1$	None	2
IJMP		Indirect Jump to (Z)	$PC \leftarrow Z$	None	2
JMP	k	Direct Jump	$PC \leftarrow k$	None	3
RCALL	k	Relative Subroutine Call	$PC \leftarrow PC + k + 1$	None	3
ICALL		Indirect Call to (Z)	$PC \leftarrow Z$	None	3
CALL	k	Direct Call	$PC \leftarrow k$	None	4
RET		Subroutine Return	$PC \leftarrow STACK$	None	4
RETI		Interrupt Return	$PC \leftarrow STACK$	I	4
CPSE	Rd,Rr	Compare, Skip if Equal	if $(Rd = Rr)$ $PC \leftarrow PC + 2$ or 3	None	1/2/3
CP	Rd,Rr	Compare	$Rd - Rr$	Z, N,V,C,H	1
CPC	Rd,Rr	Compare with Carry	$Rd - Rr - C$	Z, N,V,C,H	1
CPI	Rd,K	Compare Register with Immediate	$Rd - K$	Z, N,V,C,H	1
SBRC	Rr, b	Skip if Bit in Register Cleared	if $(Rr(b)=0)$ $PC \leftarrow PC + 2$ or 3	None	1/2/3
SBRS	Rr, b	Skip if Bit in Register is Set	if $(Rr(b)=1)$ $PC \leftarrow PC + 2$ or 3	None	1/2/3
SBIC	P, b	Skip if Bit in I/O Register Cleared	if $(P(b)=0)$ $PC \leftarrow PC + 2$ or 3	None	1/2/3
SBIS	P, b	Skip if Bit in I/O Register is Set	if $(P(b)=1)$ $PC \leftarrow PC + 2$ or 3	None	1/2/3
BRBS	s, k	Branch if Status Flag Set	if $(SREG(s) = 1)$ then $PC \leftarrow PC + k + 1$	None	1/2
BRBC	s, k	Branch if Status Flag Cleared	if $(SREG(s) = 0)$ then $PC \leftarrow PC + k + 1$	None	1/2
BREQ	k	Branch if Equal	if $(Z = 1)$ then $PC \leftarrow PC + k + 1$	None	1/2
BRNE	k	Branch if Not Equal	if $(Z = 0)$ then $PC \leftarrow PC + k + 1$	None	1/2
BRCS	k	Branch if Carry Set	if $(C = 1)$ then $PC \leftarrow PC + k + 1$	None	1/2
BRCC	k	Branch if Carry Cleared	if $(C = 0)$ then $PC \leftarrow PC + k + 1$	None	1/2
BRSH	k	Branch if Same or Higher	if $(C = 0)$ then $PC \leftarrow PC + k + 1$	None	1/2
BRLO	k	Branch if Lower	if $(C = 1)$ then $PC \leftarrow PC + k + 1$	None	1/2
BRMI	k	Branch if Minus	if $(N = 1)$ then $PC \leftarrow PC + k + 1$	None	1/2
BRPL	k	Branch if Plus	if $(N = 0)$ then $PC \leftarrow PC + k + 1$	None	1/2
BRGE	k	Branch if Greater or Equal, Signed	if $(N \oplus V = 0)$ then $PC \leftarrow PC + k + 1$	None	1/2
BRLT	k	Branch if Less Than Zero, Signed	if $(N \oplus V = 1)$ then $PC \leftarrow PC + k + 1$	None	1/2
BRHS	k	Branch if Half Carry Flag Set	if $(H = 1)$ then $PC \leftarrow PC + k + 1$	None	1/2
BRHC	k	Branch if Half Carry Flag Cleared	if $(H = 0)$ then $PC \leftarrow PC + k + 1$	None	1/2
BRTS	k	Branch if T Flag Set	if $(T = 1)$ then $PC \leftarrow PC + k + 1$	None	1/2
BRTC	k	Branch if T Flag Cleared	if $(T = 0)$ then $PC \leftarrow PC + k + 1$	None	1/2
BRVS	k	Branch if Overflow Flag is Set	if $(V = 1)$ then $PC \leftarrow PC + k + 1$	None	1/2
BRVC	k	Branch if Overflow Flag is Cleared	if $(V = 0)$ then $PC \leftarrow PC + k + 1$	None	1/2
BRIE	k	Branch if Interrupt Enabled	if $(I = 1)$ then $PC \leftarrow PC + k + 1$	None	1/2
BRID	k	Branch if Interrupt Disabled	if $(I = 0)$ then $PC \leftarrow PC + k + 1$	None	1/2

Mnemonics	Operands	Description	Operation	Flags	#Clocks
BIT AND BIT-TEST INSTRUCTIONS					
SBI	P,b	Set Bit in I/O Register	I/O(P,b) ← 1	None	2
CBI	P,b	Clear Bit in I/O Register	I/O(P,b) ← 0	None	2
LSL	Rd	Logical Shift Left	Rd(n+1) ← Rd(n), Rd(0) ← 0	Z,C,N,V	1
LSR	Rd	Logical Shift Right	Rd(n) ← Rd(n+1), Rd(7) ← 0	Z,C,N,V	1
ROL	Rd	Rotate Left Through Carry	Rd(0) ← C, Rd(n+1) ← Rd(n), C ← Rd(7)	Z,C,N,V	1
ROR	Rd	Rotate Right Through Carry	Rd(7) ← C, Rd(n) ← Rd(n+1), C ← Rd(0)	Z,C,N,V	1
ASR	Rd	Arithmetic Shift Right	Rd(n) ← Rd(n+1), n=0..6	Z,C,N,V	1
SWAP	Rd	Swap Nibbles	Rd(3..0) ← Rd(7..4), Rd(7..4) ← Rd(3..0)	None	1
BSET	s	Flag Set	SREG(s) ← 1	SREG(s)	1
BCLR	s	Flag Clear	SREG(s) ← 0	SREG(s)	1
BST	Rr, b	Bit Store from Register to T	T ← Rr(b)	T	1
BLD	Rd, b	Bit load from T to Register	Rd(b) ← T	None	1
SEC		Set Carry	C ← 1	C	1
CLC		Clear Carry	C ← 0	C	1
SEN		Set Negative Flag	N ← 1	N	1
CLN		Clear Negative Flag	N ← 0	N	1
SEZ		Set Zero Flag	Z ← 1	Z	1
CLZ		Clear Zero Flag	Z ← 0	Z	1
SEI		Global Interrupt Enable	I ← 1	I	1
CLI		Global Interrupt Disable	I ← 0	I	1
SES		Set Signed Test Flag	S ← 1	S	1
CLS		Clear Signed Test Flag	S ← 0	S	1
SEV		Set Twos Complement Overflow.	V ← 1	V	1
CLV		Clear Twos Complement Overflow	V ← 0	V	1
SET		Set T in SREG	T ← 1	T	1
CLT		Clear T in SREG	T ← 0	T	1
SEH		Set Half Carry Flag in SREG	H ← 1	H	1
CLH		Clear Half Carry Flag in SREG	H ← 0	H	1
DATA TRANSFER INSTRUCTIONS					
MOV	Rd, Rr	Move Between Registers	Rd ← Rr	None	1
MOVW	Rd, Rr	Copy Register Word	Rd+1:Rd ← Rr+1:Rr	None	1
LDI	Rd, K	Load Immediate	Rd ← K	None	1
LD	Rd, X	Load Indirect	Rd ← (X)	None	2
LD	Rd, X+	Load Indirect and Post-Inc.	Rd ← (X), X ← X + 1	None	2
LD	Rd, -X	Load Indirect and Pre-Dec.	X ← X - 1, Rd ← (X)	None	2
LD	Rd, Y	Load Indirect	Rd ← (Y)	None	2
LD	Rd, Y+	Load Indirect and Post-Inc.	Rd ← (Y), Y ← Y + 1	None	2
LD	Rd, -Y	Load Indirect and Pre-Dec.	Y ← Y - 1, Rd ← (Y)	None	2
LDD	Rd, Y+q	Load Indirect with Displacement	Rd ← (Y + q)	None	2
LD	Rd, Z	Load Indirect	Rd ← (Z)	None	2
LD	Rd, Z+	Load Indirect and Post-Inc.	Rd ← (Z), Z ← Z+1	None	2
LD	Rd, -Z	Load Indirect and Pre-Dec.	Z ← Z - 1, Rd ← (Z)	None	2
LDD	Rd, Z+q	Load Indirect with Displacement	Rd ← (Z + q)	None	2
LDS	Rd, k	Load Direct from SRAM	Rd ← (k)	None	2
ST	X, Rr	Store Indirect	(X) ← Rr	None	2
ST	X+, Rr	Store Indirect and Post-Inc.	(X) ← Rr, X ← X + 1	None	2
ST	-X, Rr	Store Indirect and Pre-Dec.	X ← X - 1, (X) ← Rr	None	2
ST	Y, Rr	Store Indirect	(Y) ← Rr	None	2
ST	Y+, Rr	Store Indirect and Post-Inc.	(Y) ← Rr, Y ← Y + 1	None	2
ST	-Y, Rr	Store Indirect and Pre-Dec.	Y ← Y - 1, (Y) ← Rr	None	2
STD	Y+q, Rr	Store Indirect with Displacement	(Y + q) ← Rr	None	2
ST	Z, Rr	Store Indirect	(Z) ← Rr	None	2
ST	Z+, Rr	Store Indirect and Post-Inc.	(Z) ← Rr, Z ← Z + 1	None	2
ST	-Z, Rr	Store Indirect and Pre-Dec.	Z ← Z - 1, (Z) ← Rr	None	2
STD	Z+q, Rr	Store Indirect with Displacement	(Z + q) ← Rr	None	2
STS	k, Rr	Store Direct to SRAM	(k) ← Rr	None	2
LPM		Load Program Memory	R0 ← (Z)	None	3
LPM	Rd, Z	Load Program Memory	Rd ← (Z)	None	3
LPM	Rd, Z+	Load Program Memory and Post-Inc	Rd ← (Z), Z ← Z+1	None	3
SPM		Store Program Memory	(Z) ← R1:R0	None	-
IN	Rd, P	In Port	Rd ← P	None	1
OUT	P, Rr	Out Port	P ← Rr	None	1
PUSH	Rr	Push Register on Stack	STACK ← Rr	None	2
POP	Rd	Pop Register from Stack	Rd ← STACK	None	2
MCU CONTROL INSTRUCTIONS					
NOP		No Operation		None	1
SLEEP		Sleep	(see specific descr. for Sleep function)	None	1

Mnemonics	Operands	Description	Operation	Flags	#Clocks
WDR		Watchdog Reset	(see specific descr. for WDR/timer)	None	1
BREAK		Break	For On-chip Debug Only	None	N/A

6. Ordering Information

Speed (MHz)	Power Supply	Ordering Code	Package	Operation Range
16	2.7 - 5.5V	AT90PWM316-16SE	SO32	Engineering Samples
16	2.7 - 5.5V	AT90PWM316-16ME	QFN32	Engineering Samples
16	2.7 - 5.5V	AT90PWM216-16SE	SO24	Engineering Samples
16	2.7 - 5.5V	AT90PWM316-16SU	SO32	Extended (-40°C to 105°C)
16	2.7 - 5.5V	AT90PWM316-16MU	QFN32	Extended (-40°C to 105°C)
16	2.7 - 5.5V	AT90PWM216-16SU	SO24	Extended (-40°C to 105°C)

Note: All packages are Pb free, fully LHF

Note: This device can also be supplied in wafer form. Please contact your local Atmel sales office for detailed ordering information and minimum quantities.

Note: Parts numbers are for shipping in sticks (SO) or in trays (QFN). These devices can also be supplied in Tape and Reel. Please contact your local Atmel sales office for detailed ordering information and minimum quantities.

7. Package Information

Package Type	
SO24	24-Lead, Small Outline Package
SO32	32-Lead, Small Outline Package
QFN32	32-Lead, Quad Flat No lead

7.1 SO24

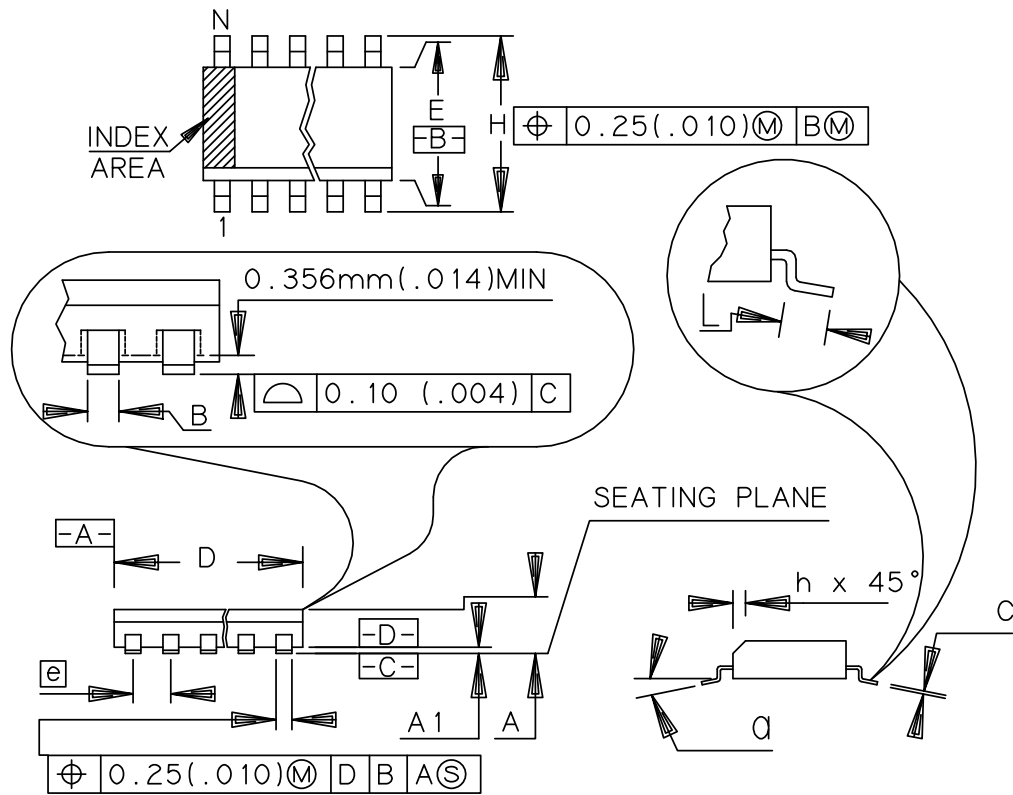

	MM		INCH	
A	2.35	2.65	.093	.104
A1	0.10	0.30	.004	.012
B	0.35	0.49	.014	.019
C	0.23	0.32	.009	.013
D	15.20	15.60	.599	.614
E	7.40	7.60	.291	.299
e	1.27	BSC	.050	BSC
H	10.00	10.65	.394	.419
h	0.25	0.75	.010	.029
L	0.40	1.27	.016	.050
N	24		24	
α	0°		8°	

07/27/07

Atmel
 Atmel Nantes S.A.
 La Chantrerie - BP 70602
 44306 Nantes Cedex 3 - France

TITLE
 TD, 24 - Lead, 0.300" Body Width
 Plastic Gull Wing Small Outline Package (SOIC)

DRAWING No. TD	REV. A
--------------------------	------------------

7.2 SO32

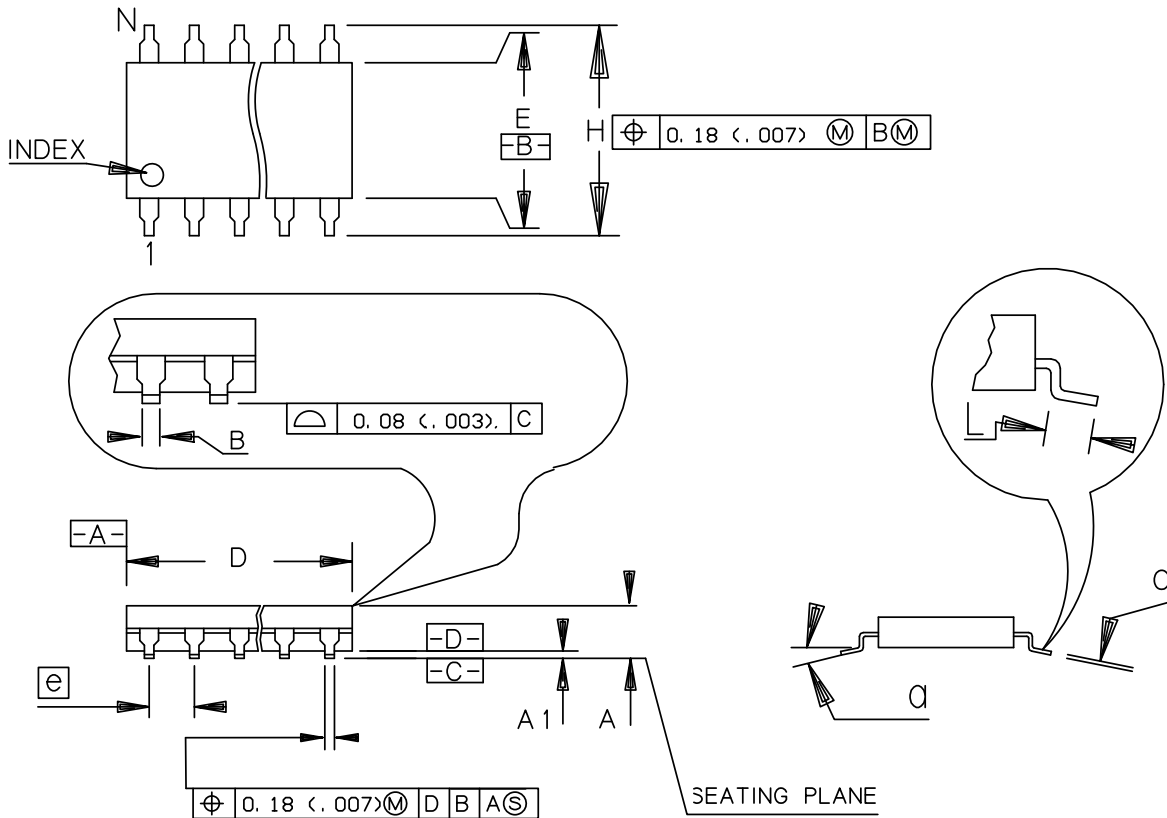

	MM		INCH	
	Min	Max	Min	Max
A	2.29	2.54	.090	.100
A1	0.10	0.25	.004	.010
B	0.36	0.51	.014	.020
C	0.15	0.32	.006	.013
D	20.57	20.88	.810	.822
E	7.42	7.60	.292	.299
e	1.27	BSC	.050	BSC
H	10.29	10.64	.405	.419
L	0.53	1.04	.021	.041
N	32		32	
α	4°		4°	

07/27/07

 Atmel Nantes S.A. La Chantrerie - BP 70602 44306 Nantes Cedex 3 - France	TITLE T4, 32 - Lead, 0.300" Body Width Plastic Gull Wing Small Outline Package (SOIC)	DRAWING No.	REV.
		T4	A

7.3 QFN32

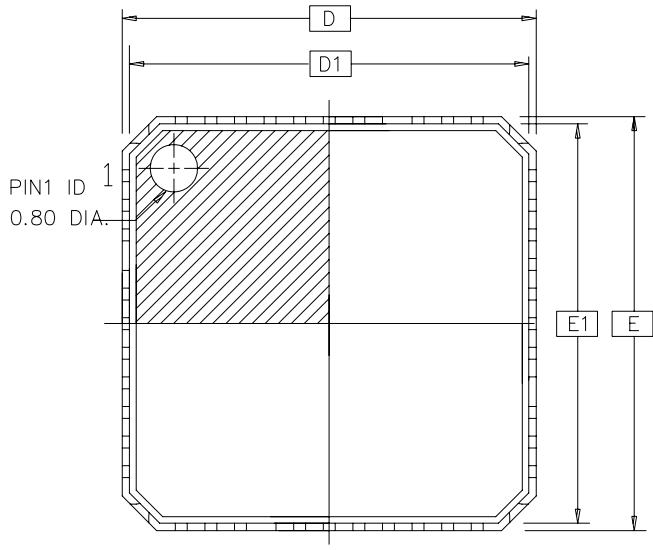

TOP VIEW

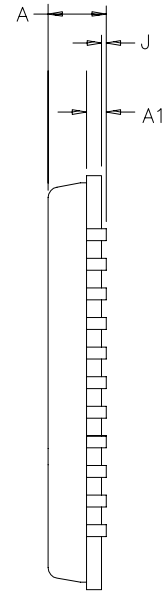

SIDE VIEW

DRAWINGS NOT SCALED

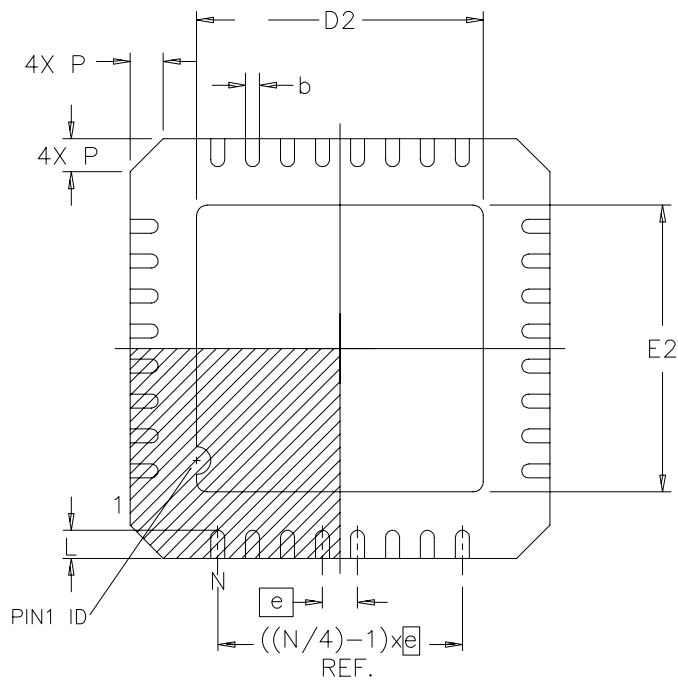

BOTTOM VIEW

	MM			INCH		
	MIN	NOM	MAX	MIN	NOM	MAX
A	0.80	-	1.00	.032	-	.040
J	0.00	0.01	0.05	.000	.000	.002
A1	0.20 ref			.008 ref		
D/E	7.00 BSC			.276 BSC		
D1/E1	6.75 BSC			.266 BSC		
D2/E2	2.25	-	5.25	.090	-	.207
N	32					
P	0.24	0.42	0.60	.009	.016	.024
e	0.65 BSC			.026 BSC		
L	0.35	-	0.75	.014	-	.030
b	0.23	-	0.35	.009	-	.014

Compliant JEDEC Standard MO-220 variation VKKC

NOTES: MLF PACKAGE FAMILY

1. DIE THICKNESS ALLOWABLE IS 0.305mm MAXIMUM(.012 INCHES MAXIMUM)
2. DIMENSIONING & TOLERANCES CONFORM TO ASME Y14.5M. – 1994.
- 3 DIMENSION b APPLIES TO PLATED TERMINAL AND IS MEASURED
BETWEEN 0.20 AND 0.25mm FROM TERMINAL TIP.
- 4 PACKAGE WARPAGE MAX 0.08mm.
- 5 THE PIN #1 IDENTIFIER MUST BE EXISTED ON THE TOP SURFACE OF THE
PACKAGE BY USING INDENTATION MARK OR OTHER FEATURE OF PACKAGE BODY.
- 6 EXACT SHAPE AND SIZE OF THIS FIXTURE IS OPTIONAL

8. Errata AT90PWM216/316

8.1 Revision C

- DAC Driver linearity above 3.6V

1. DAC Driver linearity above 3.6V

With 5V V_{CC} , the DAC driver linearity is poor when DAC output level is above $V_{CC}-1V$. At 5V, DAC output for 1023 will be around 5V - 40mV.

Work around:

Use, when $V_{CC}=5V$, V_{REF} below $V_{CC}-1V$

Or, when $V_{REF}=V_{CC}=5V$, do not use codes above 800.

8.2 Revision B

- DAC Driver linearity above 3.6V
- PSC OCRxx Register update according to PLOCK2 usage

1. DAC Driver linearity above 3.6V

With 5V V_{CC} , the DAC driver linearity is poor when DAC output level is above $V_{CC}-1V$. At 5V, DAC output for 1023 will be around 5V - 40mV.

Work around:

Use, when $V_{CC}=5V$, V_{REF} below $V_{CC}-1V$

Or, when $V_{REF}=V_{CC}=5V$, do not use codes above 800.

2. PSC OCRxx Register update according to PLOCK2 usage

If the PSC is clocked from PLL, and if PLOCK2 bit is changed at the same time as PSC end of cycle occurs, and if OCRxx registers contents have been changed, then the updated OCRxx registers contents are not predictable.

The cause is a synchronization issue between two registers in two different clock domains (PLL clock which clocks PSC and CPU clock).

Workaround:

Enable the PSC end of cycle interrupt.

At the beginning of PSC EOC interrupt vector, change PLOCK value (OCRxx registers can be updated outside the interrupt vector).

This process guarantees that UPDATE and PLOCK actions will not occur at the same moment.

8.3 Revision A

- DAC Driver linearity above 3.6V
- PSC OCRxx Register update according to PLOCK2 usage

1. DAC Driver linearity above 3.6V

With 5V V_{CC} , the DAC driver linearity is poor when DAC output level is above $V_{CC}-1V$. At 5V, DAC output for 1023 will be around 5V - 40mV.

Work around:

Use, when $V_{CC}=5V$, V_{REF} below $V_{CC}-1V$

Or, when $V_{REF}=V_{CC}=5V$, do not use codes above 800.

2. PSC OCRxx Register update according to PLOCK2 usage

If the PSC is clocked from PLL, and if PLOCK2 bit is changed at the same time as PSC end of cycle occurs, and if OCRxx registers contents have been changed, then the updated OCRxx registers contents are not predictable.

The cause is a synchronization issue between two registers in two different clock domains (PLL clock which clocks PSC and CPU clock).

Workaround:

Enable the PSC end of cycle interrupt.

At the beginning of PSC EOC interrupt vector, change PLOCK value (OCRxx registers can be updated outside the interrupt vector).

This process guarantees that UPDATE and PLOCK actions will not occur at the same moment.

9. Datasheet Revision History for AT90PWM216/316

Please note that the referring page numbers in this section are referred to this document. The referring revision in this section are referring to the document revision.

9.1 Rev. 7710H – 07/2013

1. Removed “1. History” chapter.
2. Errata:
 - “Revision C” on page 23: Errata added.
 - “Revision B” on page 23: Errata added.
 - “Revision A” on page 24: Errata updated.

9.2 Rev. 7710G – 03/2013

1. Applied the Atmel new brand template that includes new logo and new addresses.
2. Added note to the MLF/QFN package: The Center GND PADDLE has to be connected to GND.
3. Updated the [Figure 2-1 on page 3](#). Pin 18 changed to AGND instead of GND.
4. Updated the [Figure 2-2 on page 4](#). Pin 24 changed to AGND instead of GND.
5. Added note to the MLF/QFN package: The Center GND PADDLE has to be connected to GND.
6. Updated [Figure 5-2 on page 18](#).
7. Updated [Table 6-2 on page 26](#).
8. Updated “MCU Control Register – MCUCR” on page 62. Added link for Bit 4: “[Configuring the Pin](#)” on page 57.
9. Corrected “typos” in “[Overview](#)” on page 122.
10. Updated “[Features](#)” on page 122. Correct feature is: **Abnormality protection function, emergency input to force all outputs to low level.**
11. Updated “[Center Aligned Mode](#)” on page 130. The label PSCn00 and PSCn01 are incorrect and are respectively replaced by PSCn0 and PSCn1.
12. Updated the formula of “The waveform frequency is defined by the following equation” in “[Normal Mode](#)” on page 134.
13. Updated the formula of f_{AVERAGE} in “[Enhanced Mode](#)” on page 135.
14. Updated “[Input Mode Operation](#)” on page 140. Added a link to the [Table 15-6](#).
15. Updated “[PSC Synchronization](#)” on page 151. The correct content: If the PSCn has its PARUNn bit set, then it can start at the same time as PSCn-1.
16. Updated “[PSC 1 Control Register – PCTL1](#)” on page 158. Bit 4 and Bit 3 linked to “[PSC Input Configuration](#)” on page 139.
17. Updated content description of Bit 1 and Bit 3 in “[PSC 2 Synchro and Output Configuration – PSOC2](#)” on page 154.
18. Updated “[Output Compare SA Register – OCRnSAH and OCRnSAL](#)” on page 155 and “[Output Compare RB Register – OCRnRBH and OCRnRBL](#)” on page 155. The registers are R/W and not only W.
- 19.
20. Updated “[Overview](#)” on page 215. Removed “or CLKi/O/2” from the overview description.
21. Updated [Figure 19-1 on page 216](#), “[Analog Comparator Block Diagram\(1\)\(2\)](#)” .

22. Updated [“Analog Comparator Status Register – ACSR” on page 219](#). Added Bit 3 - CLKPLL
23. Updated [“Amplifier” on page 239](#). The correct content: “The ADC starting is done by setting the ADSC (ADC Start conversion) bit in the ADCSRA register”.
24. Updated [Figure 20-15 on page 240](#) and [Figure 20-16 on page 241](#). Changed CKADC to CKADC2.
25. Updated [“PSC Output Behavior During Reset” on page 266](#). If PSCRV fuse equals 0 (programmed), the selected PSC outputs will be forced to high state. If PSCRV fuse equals 1 (unprogrammed), the selected PSC outputs will be forced to low state.
26. Updated [“Electrical Characteristics” on page 283](#). Added [“DAC Characteristics” on page 290](#).
27. Updated the [Table 25-1 on page 285](#). Replaced -40°C - 85°C with -40°C to 105°C
28. Updated [Table 25-5 on page 289](#). Replaced V_{INT} parameter by A_{REF} . Min and Max values updated.

9.3 Rev. 7710F – 09/11

1. Updated [Table 8-1 on page 41](#). Added V_{POR} and V_{CCR} in the table.
2. Updated [Table 8-2 on page 42](#). Added min and max values for 101 and 010.
3. Updated [Table 25-2 on page 286](#). $V_{CC} = 1.8 - 5.5V$ columns removed.

9.4 Rev. 7710E – 08/10

1. Updated [“Port C \(PC7..PC0\)” on page 9](#).
2. Inserted a footnote [“AT90PWM216 device is available in SOIC 24-pin Package and does not have the D2A \(DAC Output\) brought out to I/O pins.” on page 9](#).
3. Updated [“Idle Mode” on page 35](#) by removing the reference to ACD.
4. Updated [“Voltage Reference Enable Signals and Start-up Time” on page 44](#). Removed reference to ACBG.
4. Updated [Table 15-14 on page 157](#); [Table 15-15 on page 158](#) and [Table 15-16 on page 159](#)
5. Removed reference to the ACCKDIV from [“Analog Comparator” on page 215](#) and from [“Register Summary” on page 11](#).
6. Updated [“ADC Prescaler Selection” on page 237](#).
7. Updated [Table 25-5 on page 289](#) with Max and Min value for Internal Voltage Reference
8. Removed AC2SADE bit from [“Register Summary” on page 11](#).

9.5 Rev. 7710D

1. Updated table page 2.
2. Updated [“Absolute Maximum Ratings*” on page 283](#)

9.6 Rev. 7710C

1. Updated table page 2.
2. Updated [Section “Internal Calibrated RC Oscillator Operating Modes\(1\)\(2\)” on page 28.](#)
3. Updated [Section “Features” on page 245.](#)
4. Updated table in [Section “Electrical Characteristics” on page 283.](#)
5. Added section [Section “Calibrated Internal RC Oscillator Accuracy” on page 285.](#)
6. Updated [Table 25-5 on page 289.](#)
7. Updated [Figure 26-36 on page 312.](#)
8. Updated [Figure 26-37 on page 313.](#)
9. Updated [Figure 26-38 on page 313.](#)

9.7 Rev. 7710B

1. Updated “Section “In-System Reprogrammable Flash Program Memory”, page 17
2. Updated [“Figure 5-1 on page 17](#)
3. Updated [“Figure 6-1 on page 26](#)
4. Updated [“Figure 6-7 on page 30](#)
5. Updated [“Table 20-1 on page 227](#)
6. Updated “Section “ADC Noise Canceler”, page 228
7. Updated [“Table 20-6 on page 237](#)
8. Added [“Table 20-7 on page 238](#)
9. Updated “Section “Amplifier”, page 239
10. Updated [“Figure 20-15 on page 240](#)
11. Added [“Figure 20-16 on page 241](#)
12. Updated [“Figure 20-17 on page 242](#)
13. Updated “Section “Amplifier 0 Control and Status register – AMP0CSR”, page 243
14. Updated [“Table 20-9 on page 243](#)
15. Updated “Section “Amplifier 1 Control and Status register – AMP1CSR”, page 244
16. Updated [“Table 20-9 on page 243](#)
17. Updated [“Table 20-11 on page 244](#)
18. Updated [“Table 23-6 on page 263](#)
19. Updated [“Table 23-7 on page 263](#)
20. Updated [“Table 23-8 on page 263](#)
21. Updated “Section “DC Characteristics”, page 284
22. Updated [“Table 25-5 on page 289](#)
23. Updated “Section “Example 1”, page 298
24. Updated “Section “Example 2”, page 298
25. Updated “Section “Example 3”, page 298
26. Added [“Figure 26-22 on page 305](#)
27. Updated “Section “Instruction Set Summary”, page 15
28. Added “Section “Errata AT90PWM216/316”, page 23

9.8 Rev. 7710A

1. Document creation.



Enabling Unlimited Possibilities®

Atmel Corporation

1600 Technology Drive
San Jose, CA 95110
USA

Tel: (+1) (408) 441-0311

Fax: (+1) (408) 487-2600

www.atmel.com

Atmel Asia Limited

Unit 01-5 & 16, 19F
BEA Tower, Millennium City 5
418 Kwun Tong Roa
Kwun Tong, Kowloon
HONG KONG

Tel: (+852) 2245-6100

Fax: (+852) 2722-1369

Atmel Munich GmbH

Business Campus
Parkring 4
D-85748 Garching b. Munich
GERMANY

Tel: (+49) 89-31970-0

Fax: (+49) 89-3194621

Atmel Japan G.K.

16F Shin-Osaki Kangyo Bldg
1-6-4 Osaki, Shinagawa-ku
Tokyo 141-0032
JAPAN

Tel: (+81) (3) 6417-0300

Fax: (+81) (3) 6417-0370

© 2013 Atmel Corporation. All rights reserved. / Rev.: 7710HS-AVR-07/2013

Atmel®, Atmel logo and combinations thereof, Enabling Unlimited Possibilities®, and others are registered trademarks or trademarks of Atmel Corporation or its subsidiaries. Other terms and product names may be trademarks of others.

Disclaimer: The information in this document is provided in connection with Atmel products. No license, express or implied, by estoppel or otherwise, to any intellectual property right is granted by this document or in connection with the sale of Atmel products. EXCEPT AS SET FORTH IN THE ATMEL TERMS AND CONDITIONS OF SALES LOCATED ON THE ATMEL WEBSITE, ATMEL ASSUMES NO LIABILITY WHATSOEVER AND DISCLAIMS ANY EXPRESS, IMPLIED OR STATUTORY WARRANTY RELATING TO ITS PRODUCTS INCLUDING, BUT NOT LIMITED TO, THE IMPLIED WARRANTY OF MERCHANTABILITY, FITNESS FOR A PARTICULAR PURPOSE, OR NON-INFRINGEMENT. IN NO EVENT SHALL ATMEL BE LIABLE FOR ANY DIRECT, INDIRECT, CONSEQUENTIAL, PUNITIVE, SPECIAL OR INCIDENTAL DAMAGES (INCLUDING, WITHOUT LIMITATION, DAMAGES FOR LOSS AND PROFITS, BUSINESS INTERRUPTION, OR LOSS OF INFORMATION) ARISING OUT OF THE USE OR INABILITY TO USE THIS DOCUMENT, EVEN IF ATMEL HAS BEEN ADVISED OF THE POSSIBILITY OF SUCH DAMAGES. Atmel makes no representations or warranties with respect to the accuracy or completeness of the contents of this document and reserves the right to make changes to specifications and products descriptions at any time without notice. Atmel does not make any commitment to update the information contained herein. Unless specifically provided otherwise, Atmel products are not suitable for, and shall not be used in, automotive applications. Atmel products are not intended, authorized, or warranted for use as components in applications intended to support or sustain life.

Looking for pricing, stock, or lifecycle information?

Click below to explore more details on WIN SOURCE:

 [View AT90PWM316-16MU on WIN SOURCE](#)

 [Atmel Information](#)

Optimize Your Supply Chain with WIN SOURCE Solutions

-  Global Sourcing Solution
-  Obsolete Management
-  Cost Control Management
-  Shortage Management
-  Alternative Solution
-  Excess Inventory Management