



**THE DATASHEET OF
FD6M045N06**



FD6M045N06

60V/60A Synchronous Rectifier Module

General Features

- Very High Rectification Efficiency at Output 12V
- Integrated Solution for Saving Board Space
- RoHS Compliant



General Description

The FD6M045N06 is one product in the Power-SPM™ family that Fairchild has newly developed and designed to be most suitable for more compact and more efficient synchronous rectification applications such as internet server power supplies and telecom system power supplies. For higher efficiency, it includes built-in very low $R_{DS(ON)}$ MOSFETs. This Power-SPM device can be used in the secondary side of the PWM transformer of forward/bridge converter to provide high current rectification at output voltages ranging from 12 Volts down to 5 Volts. With this product, it is possible to design the secondary side of power supply systems with reduced parasitic elements resulting in minimized voltage spike and EMI noise.

MOSFET Features

- $V_{DS} = 60V$
- $Q_{G(TOTAL)} = 66nC(Typ.)$, $V_{GS} = 10V$
- $R_{DS(ON)} = 3.6m\Omega(Typ.)$, $V_{GS} = 10V$, $I_D = 40A$
- Low Miller Charge
- Low Q_{rr} Body Diode
- UIS Capability (Single Pulse and Repetitive Pulse)
- Fully Isolated Package

Applications

- High Current Isolated Converter
- Distributed Power Architectures
- Synchronous Rectification
- DC/DC Converter
- Battery Supplied Application
- ORing MOSFET

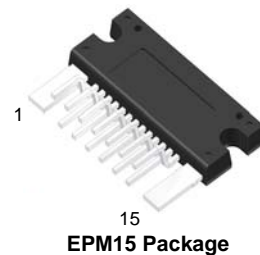

Block Diagram

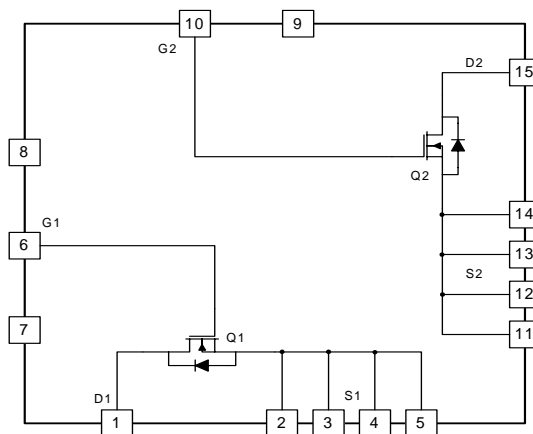

Figure 1. FD6M045N06 Module Block Diagram

Pin Configuration and Pin Description

Top View

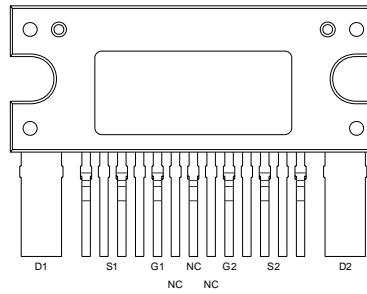

Figure 2. Pinmap of FD6M045N06

Pin Number	Pin Name	Pin Description
1	D1	Drain of Q1, MOSFET
2 ~ 5	S1	Source of Q1, MOSFET
6	G1	Gate of Q1, MOSFET
7	NC	No Connection
8	NC	No Connection
9	NC	No Connection
10	G2	Gate of Q2, MOSFET
11 ~ 14	S2	Source of Q2, MOSFET
15	D2	Drain of Q2, MOSFET

Absolute Maximum Ratings $T_C = 25^\circ\text{C}$, Unless Otherwise Specified

Symbol	Parameter	Rating	Unit
V_{DS}	Drain to Source Voltage (Note1)	60	V
V_{GS}	Gate to Source Voltage	± 20	V
I_D	Drain Current, Continuous ($V_{GS} = 10\text{V}$) (Note1)	60	A
E_{AS}	Single Pulse Avalanche Energy (Note1,2)	794	mJ
T_J, T_{STG}	Operating and Storage Temperature Range	-40 ~ 150	$^\circ\text{C}$

Thermal Resistance

Symbol	Parameter	Min.	Typ.	Max.	Unit
$R_{\theta JC}$	Junction to Case Thermal Resistance (Note1)	-	-	3.9	$^\circ\text{C}/\text{W}$

Note:

- Each MOSFET Switch
- Starting $T_J = 25^\circ\text{C}$, $V_D = 40\text{V}$, $L = 0.25\text{mH}$, $I_{AS} = 46\text{A}$

Electrical Characteristics $T_C = 25^\circ\text{C}$, Unless Otherwise Specified

Symbol	Parameter	Test Conditions	Min.	Typ.	Max.	Units
--------	-----------	-----------------	------	------	------	-------

Synchronous Rectifier Switch Part (Each Switch)

BV_{DSS}	Drain to Source Breakdown Voltage	$I_D = 250\mu\text{A}$, $V_{GS} = 0\text{V}$	60	-	-	V
I_{DSS}	Zero Gate Voltage Drain Current	$V_{GS} = 0\text{V}$, $V_{DS} = 48\text{V}$	-	-	1	μA
I_{GSS}	Gate to Source Leakage Current	$V_{GS} = \pm 20\text{V}$	-	-	± 100	nA
$V_{GS(TH)}$	Gate Threshold Voltage	$V_D = 20\text{V}$, $I_{DS} = 250\mu\text{A}$	2.0	-	4.0	V
$R_{DS(ON)}$	Drain to Source On Resistance	$I_D = 40\text{A}$, $V_{GS} = 10\text{V}$	-	3.55	4.5	m Ω
			$T_J = 150^\circ\text{C}$	-	6.7	

Dynamic Characteristics

C_{ISS}	Input Capacitance	$V_{DS} = 25\text{V}$, $V_{GS} = 0\text{V}$ $f = 1\text{MHz}$	-	3890	-	pF
C_{OSS}	Output Capacitance		-	755	-	pF
C_{RSS}	Reverse Transfer Capacitance		-	270	-	pF
$Q_{g(TOT)}$	Total Gate Charge at 10V	$V_{GS} = 0\text{V}$ to 10V	-	66	87	nC
$Q_{g(TH)}$	Threshold Gate Charge	$V_{GS} = 0\text{V}$ to 2V	-	7	10	nC
Q_{gs}	Gate to Source Gate Charge	$V_{DD} = 40\text{V}$ $I_D = 40\text{A}$ $I_g = 1.0\text{mA}$	-	18	-	nC
Q_{gs2}	Gate Charge Threshold to Plateau		-	11	-	nC
Q_{gd}	Gate to Drain "Miller" Charge		-	20	-	nC

Switching Characteristics ($V_{GS} = 10\text{V}$)

t_{ON}	Turn-On Time	$I_D = 40\text{A}$ $V_{GS} = 10\text{V}$, $V_{DD} = 40\text{V}$, $R_G = 5\Omega$	-	-	60	ns
$t_{d(on)}$	Turn-On Delay Time		-	18	-	ns
t_r	Rise Time		-	19	-	ns
$t_{d(off)}$	Turn-Off Delay Time		-	35	-	ns
t_f	Fall Time		-	23	-	ns
t_{OFF}	Turn-Off Time		-	-	100	ns

Drain-Source Diode Characteristics

V_{SD}	Source to Drain Diode Voltage	$I_{SD} = 80\text{A}$, $V_{GS} = 0\text{V}$	-	-	1.25	V
		$I_{SD} = 40\text{A}$, $V_{GS} = 0\text{V}$	-	-	1.0	
t_{rr}	Reverse Recovery Time	$I_{SD} = 40\text{A}$, $dI_{SD}/dt = 100\text{A}/\mu\text{s}$	-	33	-	ns
Q_{rr}	Reverse Recovery Charge	$I_{SD} = 40\text{A}$, $dI_{SD}/dt = 100\text{A}/\mu\text{s}$	-	34	-	nC

Typical Performance Characteristics Each Switch, Unless Otherwise Specified

Figure 3. On-Region Characteristics

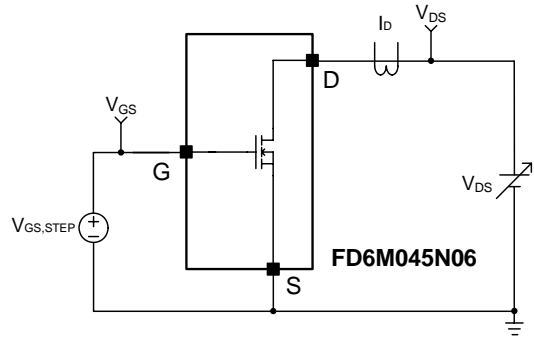
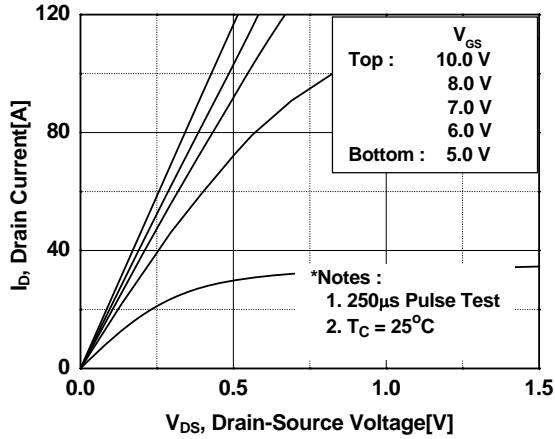

Figure 4. Transfer Characteristics

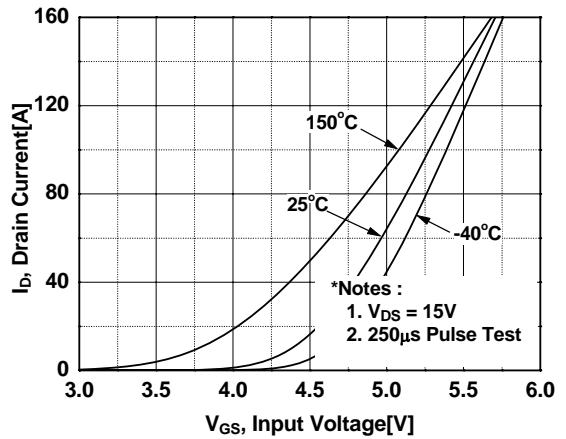
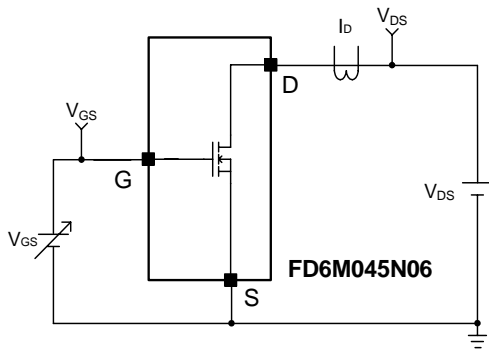

Figure 5. Body Diode Forward Voltage Variation vs. Source Current and Temperature

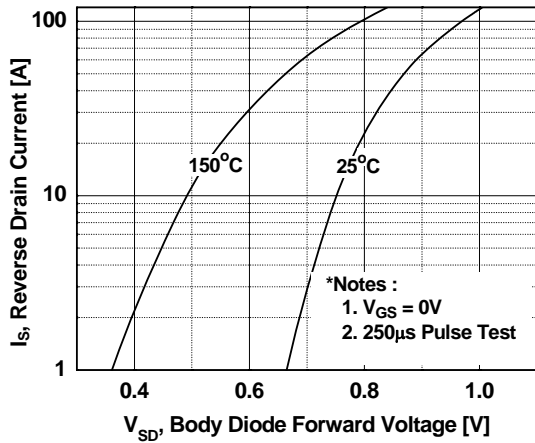
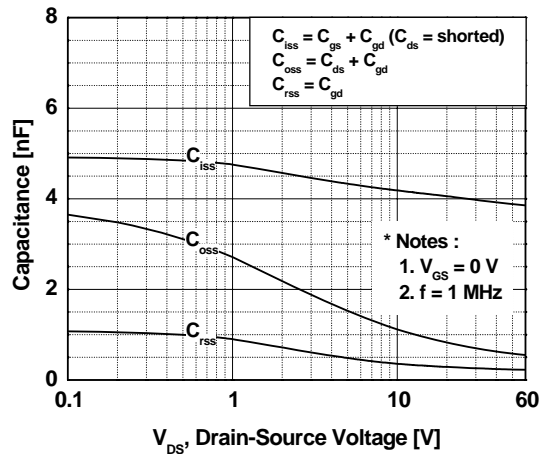

Figure 6. Output Capacitance Characteristics



Typical Performance Characteristics (Continued)

Figure 7. Breakdown Voltage Variation vs. Temperature

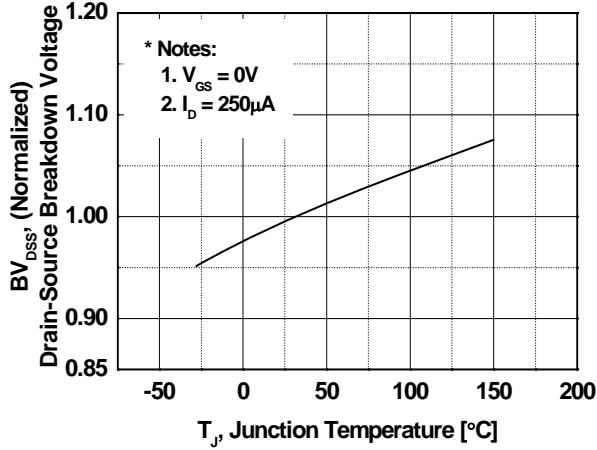

Figure 8. On-Resistance Variation vs. Temperature

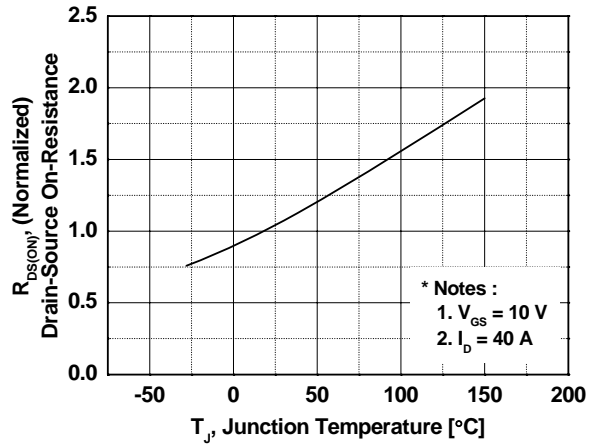

Figure 9. Transient Thermal Response Curve

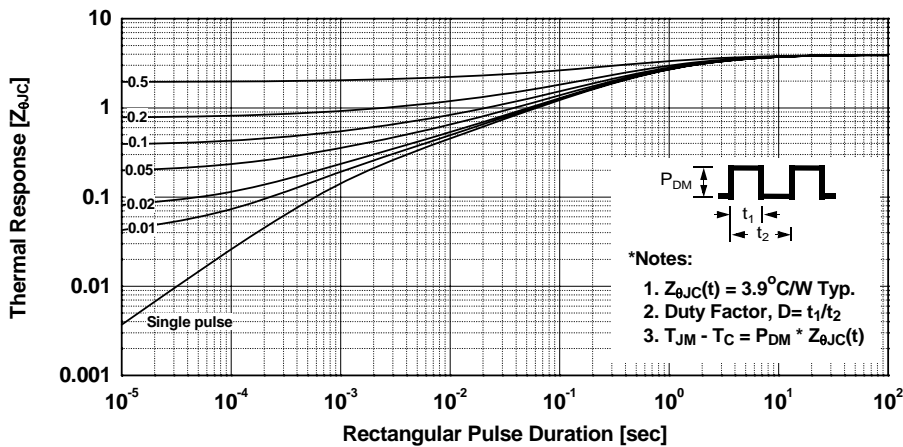

Figure 10. Maximum Safe Operating Area

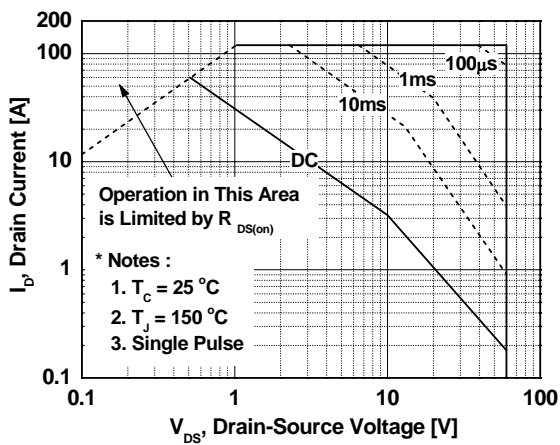
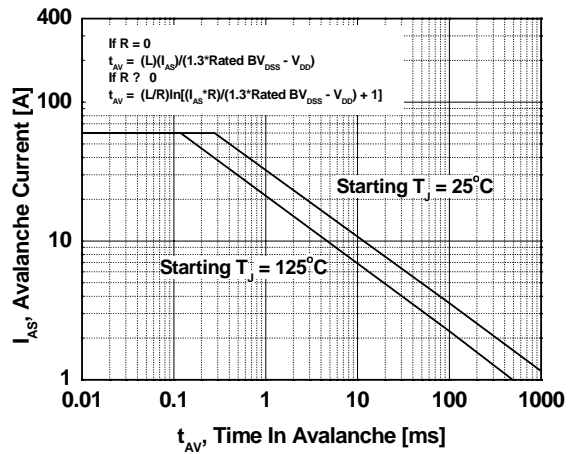

Figure 11. Unclamped Inductive Switching Capability



AC Test Circuits and Waveforms

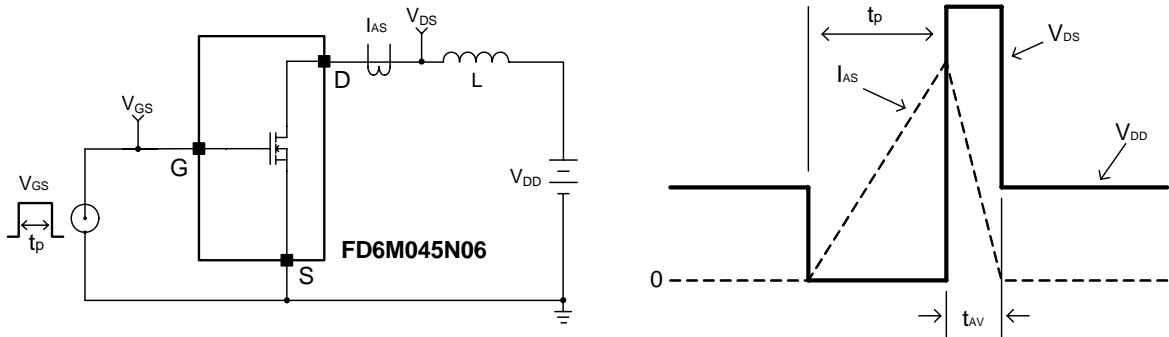

Figure 12. Unclamped Inductive Switching Test Circuit and Waveforms

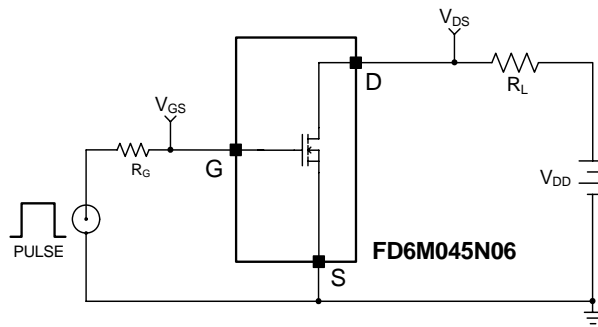

Figure 13. Switching Test Circuit

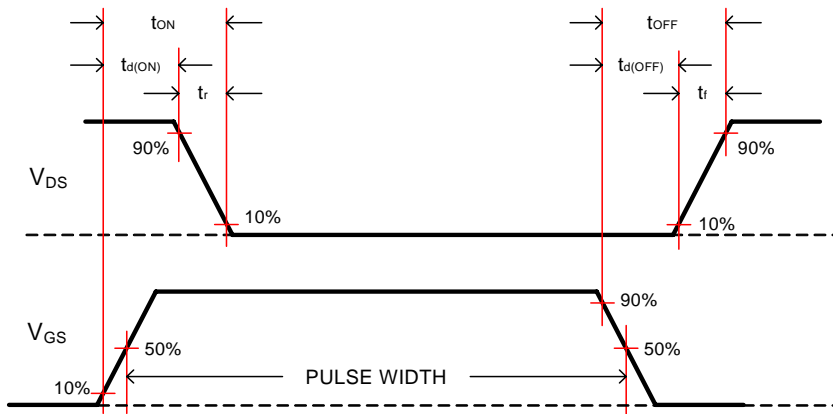

Figure 14. Switching Test Waveforms

Application circuits

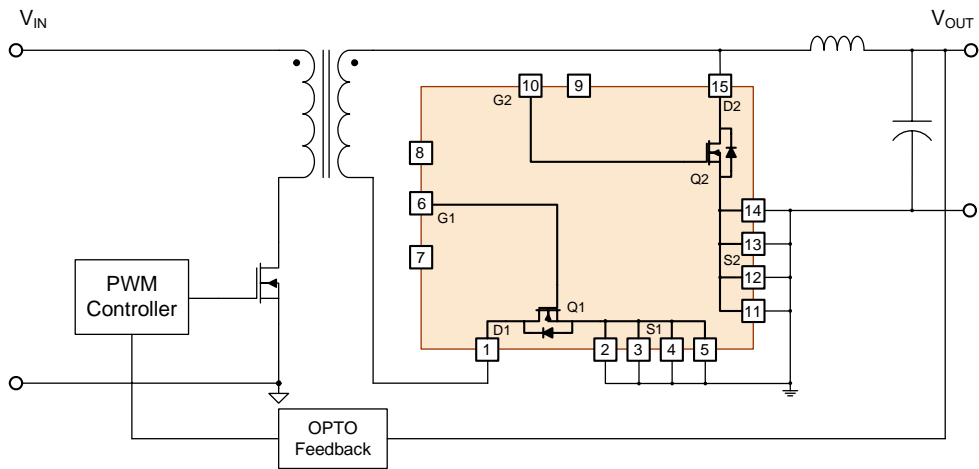

Figure 3. Application Circuit of Forward Converter with FD6M045N06

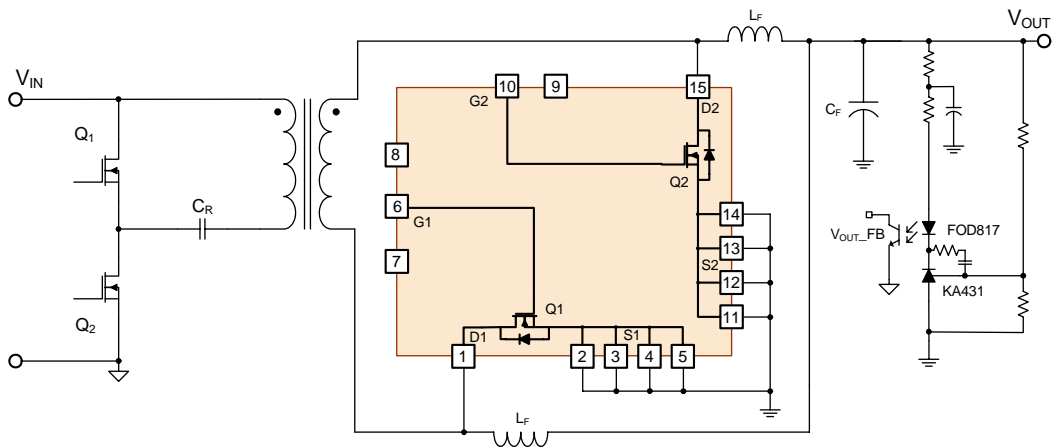

Figure 4. Application Circuit of Asymmetrical HB Converter with FD6M045N06

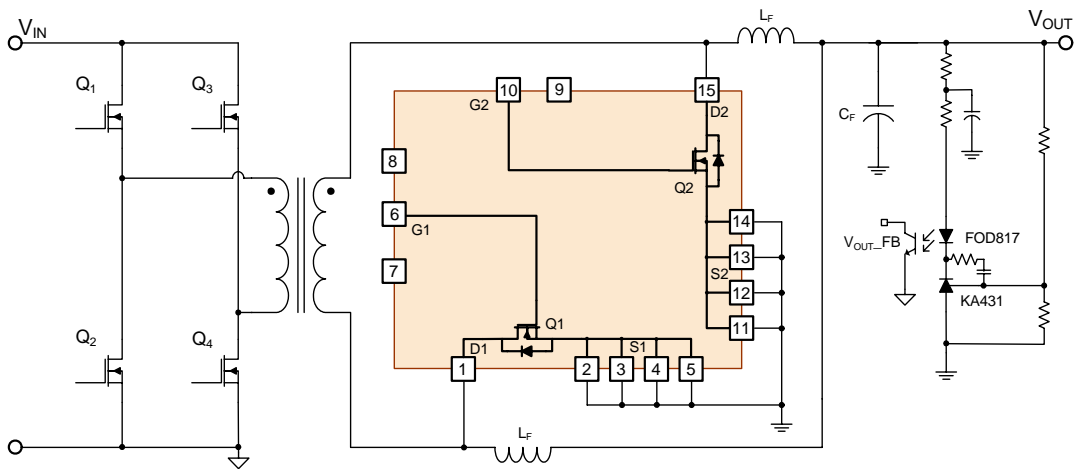
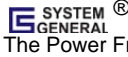





Figure 5. Application Circuit of Full Bridge Converter with FD6M045N06



TRADEMARKS

The following includes registered and unregistered trademarks and service marks, owned by Fairchild Semiconductor and/or its global subsidiaries, and is not intended to be an exhaustive list of all such trademarks.

- | | | | |
|---|---|--|---|
| ACEx [®] | FPS [™] | PDP-SPM [™] | SupreMOST [™] |
| Build it Now [™] | FRFET [®] | Power220 [®] | SyncFET [™] |
| CorePLUS [™] | Global Power Resource SM | POWEREDGE [®] |  SYSTEM GENERAL [®] |
| CROSSVOLT [™] | Green FPS [™] | Power-SPM [™] | The Power Franchise [®] |
| CTL [™] | Green FPS [™] e-Series [™] | PowerTrench [®] |  the power franchise |
| Current Transfer Logic [™] | GTO [™] | Programmable Active Droop [™] | TinyBoost [™] |
| EcoSPARK [®] | <i>i-Lo</i> [™] | QFET [®] | TinyBuck [™] |
| EZSWITCH [™] * | IntelliMAX [™] | QST [™] | TinyLogic [®] |
|  ™ | ISOPLANAR [™] | QT Optoelectronics [™] | TINYOPTO [™] |
|  ™ | MegaBuck [™] | Quiet Series [™] | TinyPower [™] |
| Fairchild [®] | MICROCOUPLER [™] | RapidConfigure [™] | TinyPWM [™] |
| Fairchild Semiconductor [®] | MicroFET [™] | SMART START [™] | TinyWire [™] |
| FACT Quiet Series [™] | MicroPak [™] | SPM [®] | μSerDes [™] |
| FACT [®] | MillerDrive [™] | STEALTH [™] | UHC [®] |
| FAST [®] | Motion-SPM [™] | SuperFET [™] | Ultra FRFET [™] |
| FastvCore [™] | OPTOLOGIC [®] | SuperSOT [™] -3 | UniFET [™] |
| FlashWriter [®] * | OPTOPLANAR [®] | SuperSOT [™] -6 | VCX [™] |
| |  ™ | SuperSOT [™] -8 | |

* EZSWITCH[™] and FlashWriter[®] are trademarks of System General Corporation, used under license by Fairchild Semiconductor.

DISCLAIMER

FAIRCHILD SEMICONDUCTOR RESERVES THE RIGHT TO MAKE CHANGES WITHOUT NOTICE TO ANY PRODUCTS HEREIN TO IMPROVE RELIABILITY, FUNCTION, OR DESIGN. FAIRCHILD DOES NOT ASSUME ANY LIABILITY ARISING OUT OF THE APPLICATION OR USE OF ANY PRODUCT OR CIRCUIT DESCRIBED HEREIN; NEITHER DOES IT CONVEY ANY LICENSE UNDER ITS PATENT RIGHTS, NOR THE RIGHTS OF OTHERS. THESE SPECIFICATIONS DO NOT EXPAND THE TERMS OF FAIRCHILD'S WORLDWIDE TERMS AND CONDITIONS, SPECIFICALLY THE WARRANTY THEREIN, WHICH COVERS THESE PRODUCTS.

LIFE SUPPORT POLICY

FAIRCHILD'S PRODUCTS ARE NOT AUTHORIZED FOR USE AS CRITICAL COMPONENTS IN LIFE SUPPORT DEVICES OR SYSTEMS WITHOUT THE EXPRESS WRITTEN APPROVAL OF FAIRCHILD SEMICONDUCTOR CORPORATION.

As used herein:

- Life support devices or systems are devices or systems which, (a) are intended for surgical implant into the body or (b) support or sustain life, and (c) whose failure to perform when properly used in accordance with instructions for use provided in the labeling, can be reasonably expected to result in a significant injury to the user.
- A critical component in any component of a life support, device or system whose failure to perform can be reasonably expected to cause the failure of the life support device or system, or to affect its safety or effectiveness.

PRODUCT STATUS DEFINITIONS



Definition of Terms

Datasheet Identification	Product Status	Definition
Advance Information	Formative or In Design	This datasheet contains the design specifications for product development. Specifications may change in any manner without notice.
Preliminary	First Production	This datasheet contains preliminary data; supplementary data will be published at a later date. Fairchild Semiconductor reserves the right to make changes at any time without notice to improve design.
No Identification Needed	Full Production	This datasheet contains final specifications. Fairchild Semiconductor reserves the right to make changes at any time without notice to improve design.
Obsolete	Not In Production	This datasheet contains specifications on a product that has been discontinued by Fairchild Semiconductor. The datasheet is printed for reference information only.

Rev. 133

Looking for pricing, stock, or lifecycle information?

Click below to explore more details on WIN SOURCE:

-  [View FD6M045N06 on WIN SOURCE](#)
-  [Fairchild/ON Semiconductor Information](#)

Optimize Your Supply Chain with WIN SOURCE Solutions

-  Global Sourcing Solution
-  Obsolete Management
-  Cost Control Management
-  Shortage Management
-  Alternative Solution
-  Excess Inventory Management