

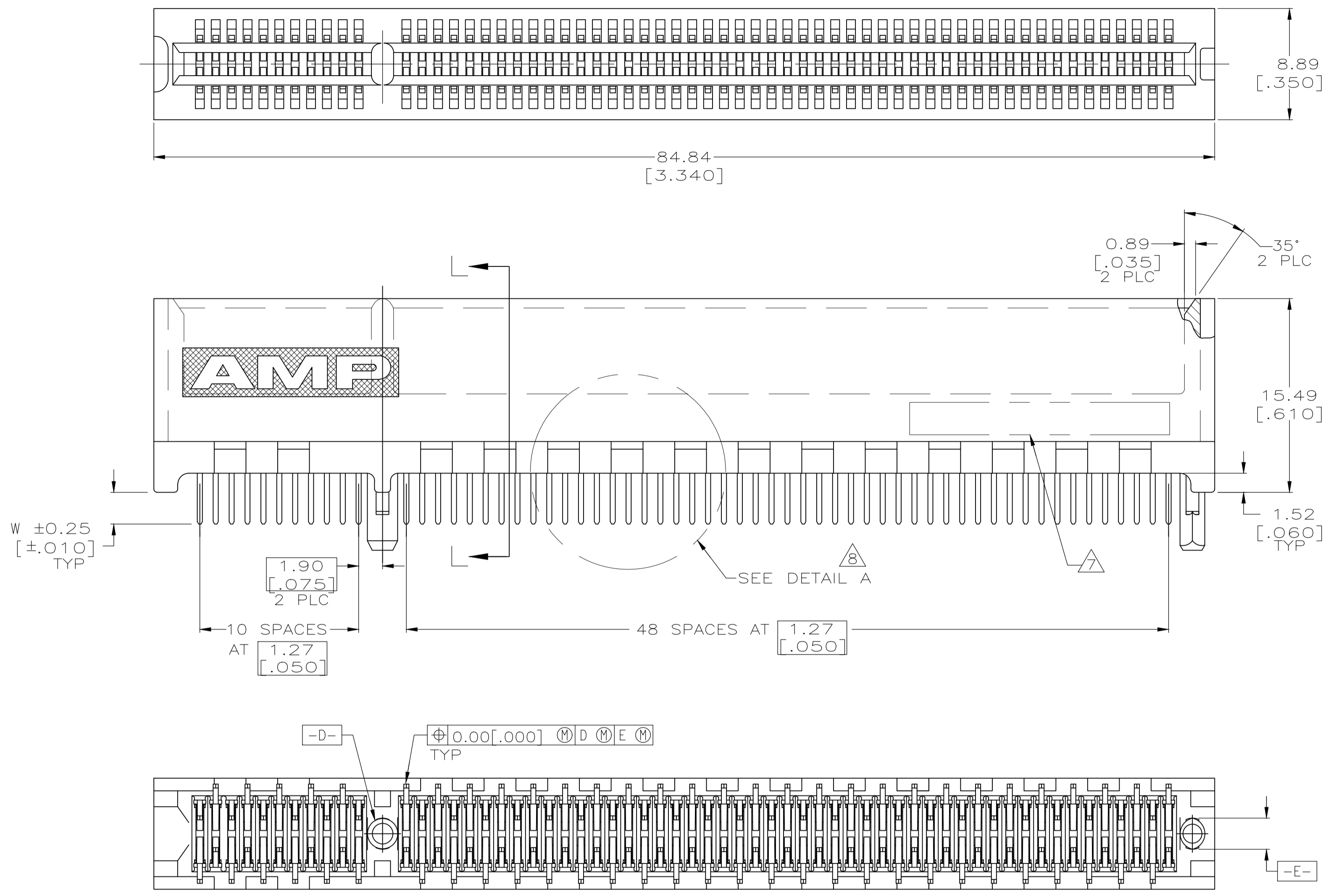

THE DATASHEET OF
5145154-4



REVISIONS					
P	LTR	DESCRIPTION	DATE	DMN	APVD
F		ECO-18-017212	30NOV2018	FL	HL



SEE SHEET 2 FOR HOLE PATTERN

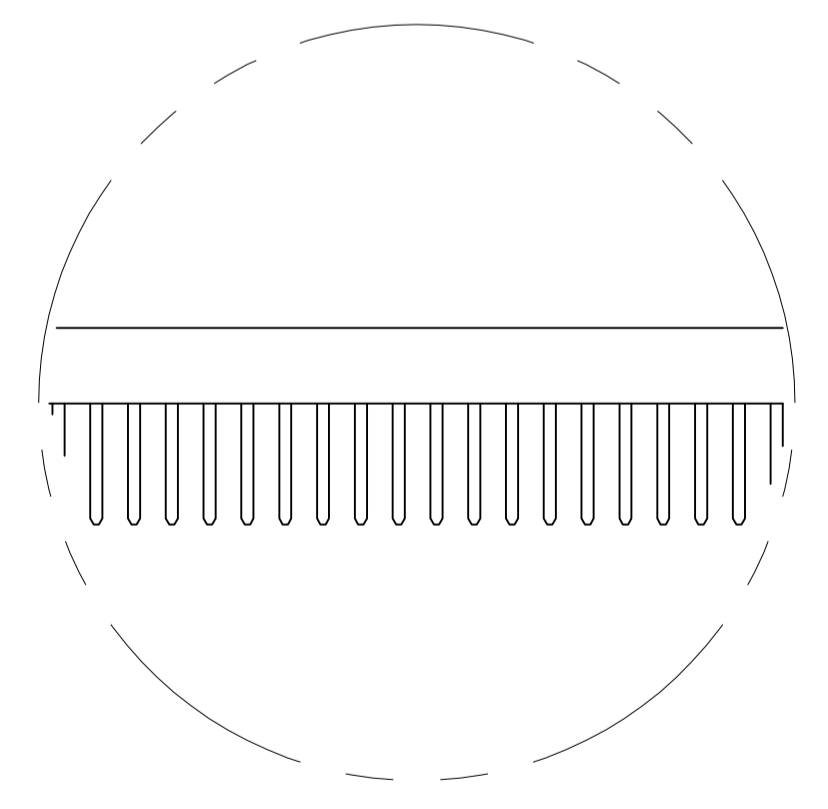

- 1 HOUSING: HIGH TEMPERATURE THERMOPLASTIC. COLOR - NATURAL
- 2 CONTACT: PHOSPHOR BRONZE.
- 3 CONTACT FINISH: .001269[.000050] MIN NICKEL ALL OVER. GOLD FLASH OVER NICKEL IN CONTACT AREA. .002537[.000100] MIN TIN OVER NICKEL ON SOLDER TAILS.
- 4 CONTACT FINISH: .001269[.000050] MIN NICKEL ALL OVER. .000375[.000015] MIN GOLD OVER NICKEL IN CONTACT AREA. .002537[.000100] MIN TIN OVER NICKEL ON SOLDER TAILS.
- 5 CONTACT FINISH: .001269[.000050] MIN NICKEL ALL OVER. .000757[.000030] MIN GOLD OVER NICKEL IN CONTACT AREA. .002537[.000100] MIN TIN OVER NICKEL ON SOLDER TAILS.
- 6 DISTANCE FROM CONTACT POINT TO BOTTOM OF CARD SLOT.
- 7 TE CONNECTIVITY PART NUMBER, DATE CODE AND CSA LOGO SHOULD BE MARKED ON THE SIDE OF THE HOUSING NEAR THE AMP LOGO.
- 8 CORED OR SOLID SIDE WALLS ARE AT DISCRETION OF TE CONNECTIVITY
- 9 PIN 44~49 AND PIN 104~109 ARE NOT LOADED.

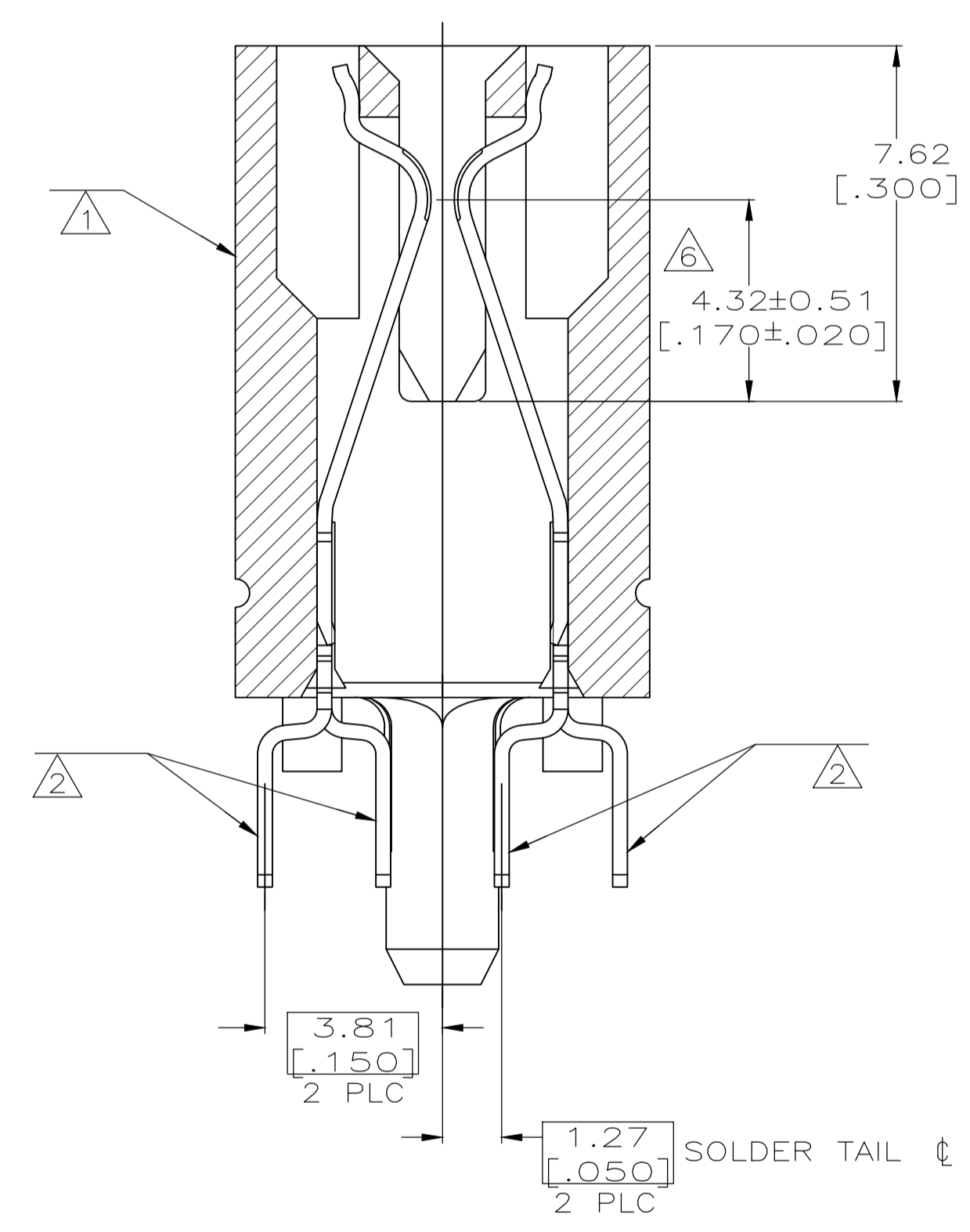

3.56 [.140]	5	1-5145154-2
3.18 [.125]	5	5145154-8
2.54 [.100]	5	5145154-4
2.54 [.100]	4	5145154-2
2.54 [.100]	3	5145154-1
W	FINISH	PART NUMBER

THIS DRAWING IS A CONTROLLED DOCUMENT.

DIMENSIONS: mm [INCHES]	TOLERANCES UNLESS OTHERWISE SPECIFIED:	0 PLC ± -	1 PLC ± -	2 PLC ± .25[.01]	3 PLC ± .125 [.005]	4 PLC ± -	ANGLES ± ± °
MATERIAL		FINISH		WEIGHT		CUSTOMER DRAWING	

DMN	AL FRANTUM	20 MAY 04
CHK	AL FRANTUM	20 MAY 04
APVD		
NAME	CONNECTOR ASSEMBLY, 60 DUAL POSITION, 1.27 [.050] SERIES, CARD EDGE	
PRODUCT SPEC	108-14034	
APPLICATION SPEC	114-26012	
SIZE	CAGE CODE	DRAWING NO
A1	00779	5145154
RESTRICTED TO	SCALE	SHEET
	4:1	1 OF 4
REV	F	

STE TE Connectivity Ltd.

REVISIONS				
P	LTR	DESCRIPTION	DATE	APPV
-	-	SEE SHEET 1	-	-

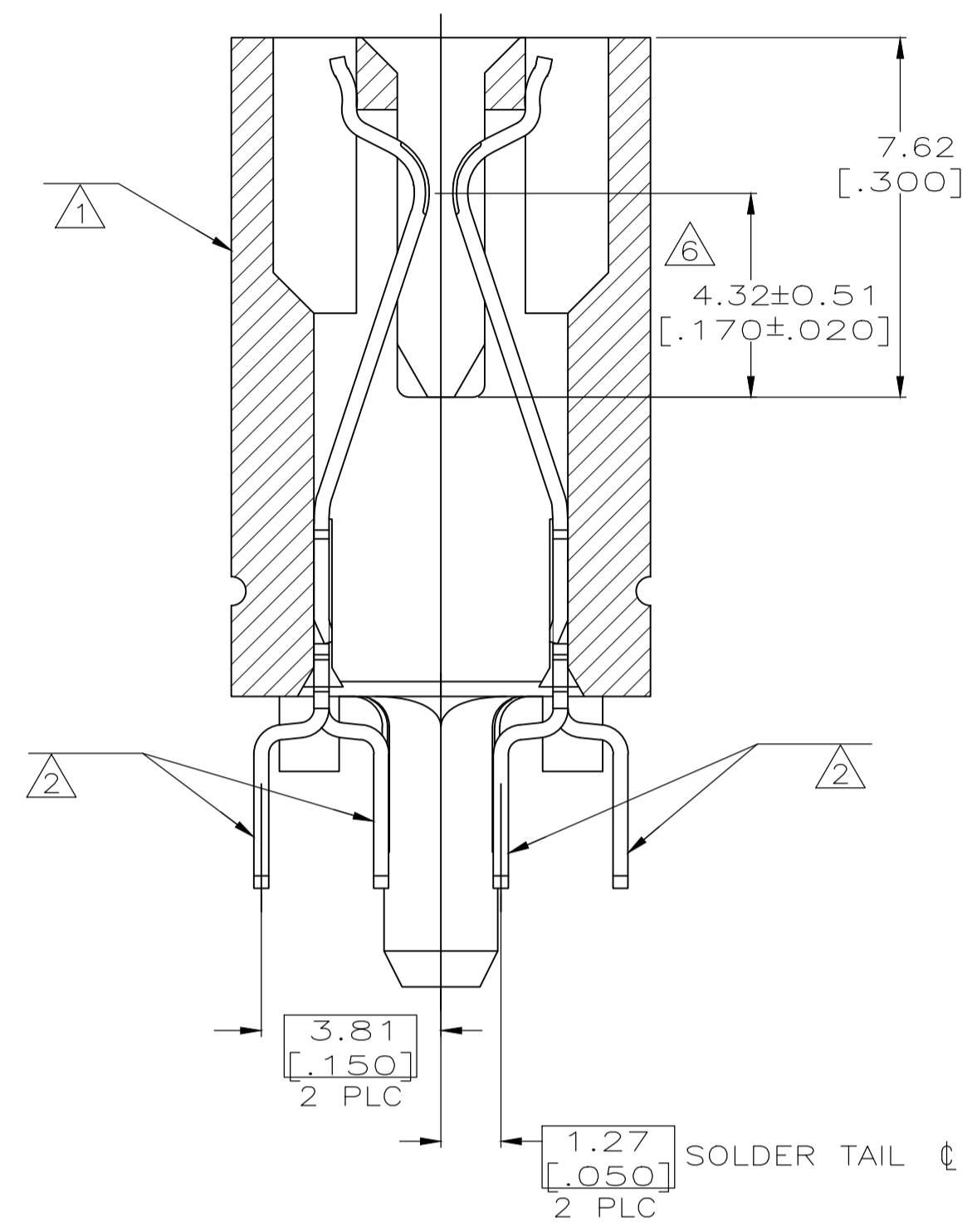
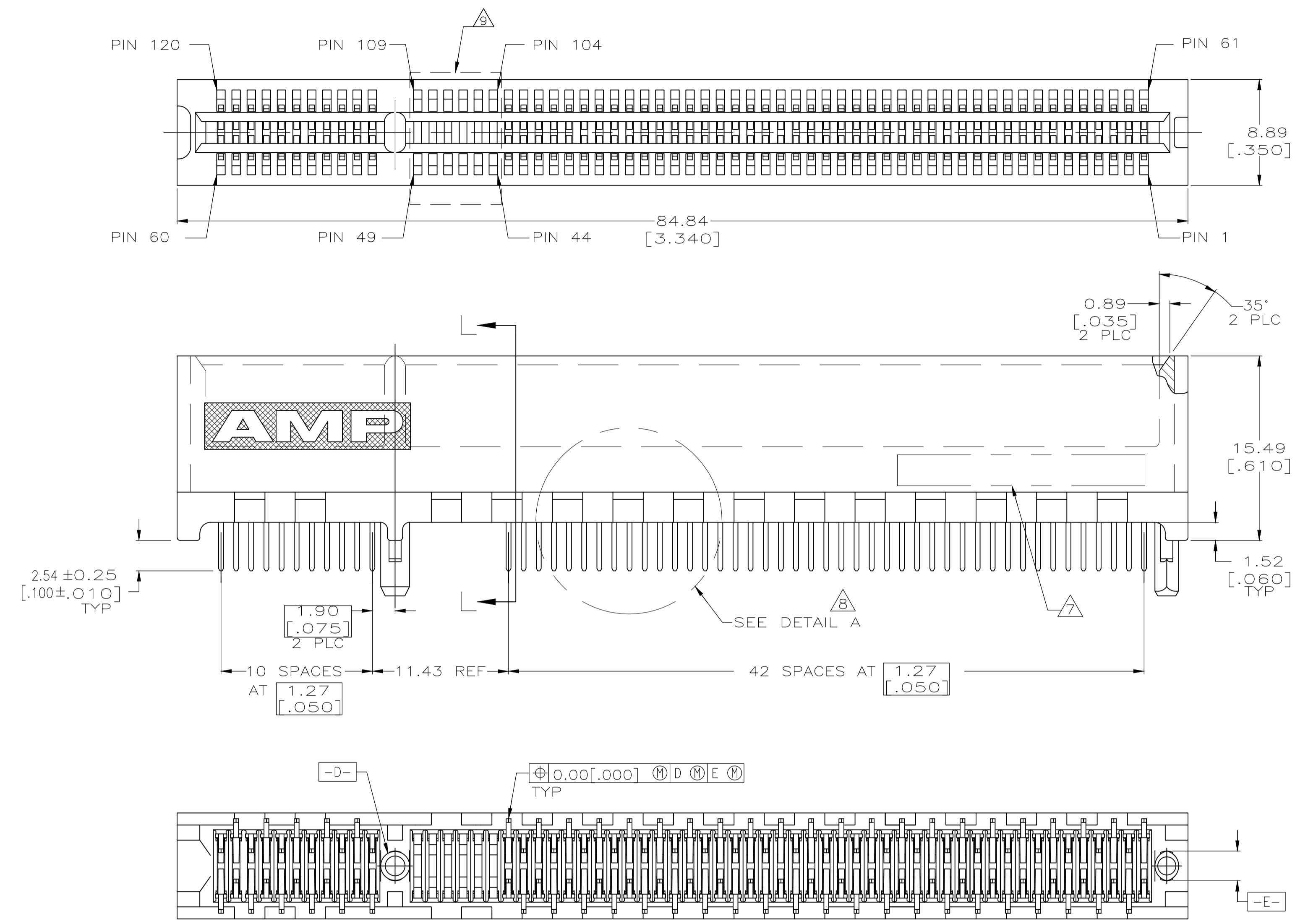

SECTION L-L
SCALE 8:1

SEE SHEET 4 FOR HOLE PATTERN

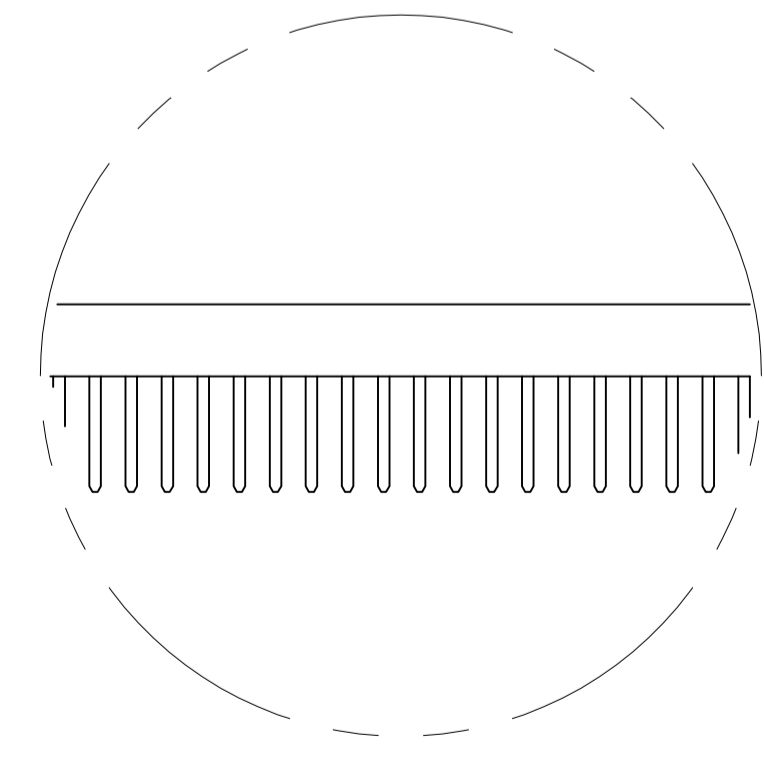

DETAIL A

SELECT LOADED TYPE AS SHOWN.

	2-5145154-1
FINISH	PART NUMBER

THIS DRAWING IS A CONTROLLED DOCUMENT.		DIN AL FRANTUM 20 MAY 04 CHK AL FRANTUM 20 MAY 04 APVD -	NAME PRODUCT SPEC 108-14034 APPLICATION SPEC 114-26012	SIZE A1	CAGE CODE 00779	DRAWING NO 5145154	RESTRICTED TO -	
DIMENSIONS: mm (INCHES)	TOLERANCES UNLESS OTHERWISE SPECIFIED: 0 PLC ± - 1 PLC ± - 2 PLC ± .25 [.01] 3 PLC ± .125 [.005] 4 PLC ± - 2° ANGLES ± - 2°	MATERIAL -	FINISH -	WEIGHT -	CUSTOMER DRAWING	SCALE 4:1	SHEET 3 OF 4	REV F

Looking for pricing, stock, or lifecycle information?

Click below to explore more details on WIN SOURCE:

 [View 5145154-4 on WIN SOURCE](#)

 [TE Connectivity](#) Information

Optimize Your Supply Chain with WIN SOURCE Solutions

-  Global Sourcing Solution
-  Obsolete Management
-  Cost Control Management
-  Shortage Management
-  Alternative Solution
-  Excess Inventory Management