



**THE DATASHEET OF
CD74HCT356E**



High-Speed CMOS Logic 8-Input Multiplexer/Register, Three-State

SCLS459A - June 2001 - Revised May 2003

Features

- Edge-Triggered Data Flip-Flops
 - Transparent Select Latches
- Buffered Inputs
- 3-State Complementary Outputs
- Bus Line Driving Capability
- Typical Propagation Delay: $V_{CC} = 5V$, $C_L = 15pF$, $T_A = 25^{\circ}C$
 - Clock to Output = 22ns
- Fanout (Over Temperature Range)
 - Standard Outputs 10 LSTTL Loads
 - Bus Driver Outputs 15 LSTTL Loads
- Wide Operating Temperature Range . . . $-55^{\circ}C$ to $125^{\circ}C$
- Balanced Propagation Delay and Transition Times
- Significant Power Reduction Compared to LSTTL Logic ICs
- 4.5V to 5.5V Operation
- Direct LSTTL Input Logic Compatibility, $V_{IL} = 0.8V$ (Max), $V_{IH} = 2V$ (Min)
- CMOS Input Compatibility, $I_I \leq 1\mu A$ at V_{OL} , V_{OH}

Description

The CD74HCT356 consists of data selectors/multiplexers that select one of eight sources. The data select bits (S0, S1, and S2) are stored in transparent latches that are enabled by a low latch enable input (LE).

The data is stored in edge-triggered flip-flops that are triggered by a low-to-high clock transition.

In both types the 3-state outputs are controlled by three output-enable inputs ($\overline{OE1}$, $\overline{OE2}$, and $\overline{OE3}$).

Ordering Information

PART NUMBER	TEMP. RANGE (°C)	PACKAGE
CD74HCT356E	-55 to 125	20 Ld PDIP
CD74HCT356M96	-55 to 125	20 Ld SOIC

NOTE: When ordering, use the entire part number. The suffix 96 denotes tape and reel.

Pinout

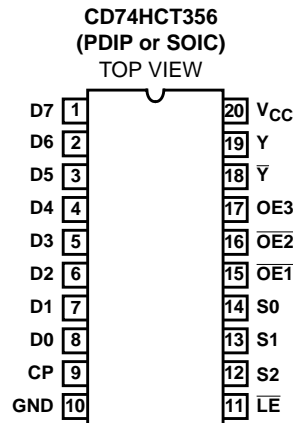

CD74HCT356

Functional Diagram

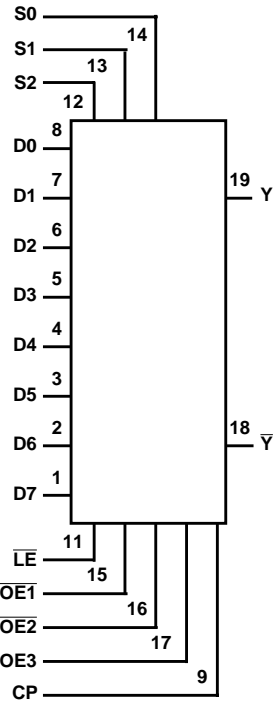

TRUTH TABLE

INPUTS							OUTPUTS	
SELECT (NOTE 1)			CLOCK	OUTPUT ENABLES				
S2	S1	S0	CP	OE1	OE2	OE3	Y-bar	Y
X	X	X	X	H	X	X	Z	Z
X	X	X	X	X	H	X	Z	Z
X	X	X	X	X	X	L	Z	Z
L	L	L	↑	L	L	H	D0-bar	D0
L	L	L	H or L	L	L	H	D0n-bar	D0n
L	L	H	↑	L	L	H	D1-bar	D1
L	L	H	H or L	L	L	H	D1n-bar	D1n
L	H	L	↑	L	L	H	D2-bar	D2
L	H	L	H or L	L	L	H	D2n-bar	D2n
L	H	H	↑	L	L	H	D3-bar	D3
L	H	H	H or L	L	L	H	D3n-bar	D3n
H	L	L	↑	L	L	H	D4-bar	D4
H	L	L	H or L	L	L	H	D4n-bar	D4n
H	L	H	↑	L	L	H	D5-bar	D5
H	L	H	H or L	L	L	H	D5n-bar	D5n
H	H	L	↑	L	L	H	D6-bar	D6
H	H	L	H or L	L	L	H	D6n-bar	D6n

CD74HCT356

TRUTH TABLE (Continued)

INPUTS							OUTPUTS	
SELECT (NOTE 1)			CLOCK	OUTPUT ENABLES				
S2	S1	S0	CP	$\overline{OE1}$	$\overline{OE2}$	OE3	\overline{Y}	Y
H	H	H	↑	L	L	H	$\overline{D7}$	D7
H	H	H	H or L	L	L	H	$\overline{D7}_n$	D7 _n

H = High Voltage Level (Steady State); L = Low Voltage Level (Steady State); ↑ = Transition from Low to High Level;
 X = Don't Care; Z = High-Impedance State (Off State); D0_n...D7_n = the level of steady-state inputs D0 through D7, respectively,
 before the most recent low-to-high transition of data control.

NOTE:

1. This column shows the input address setup with \overline{LE} low.

Block Diagram

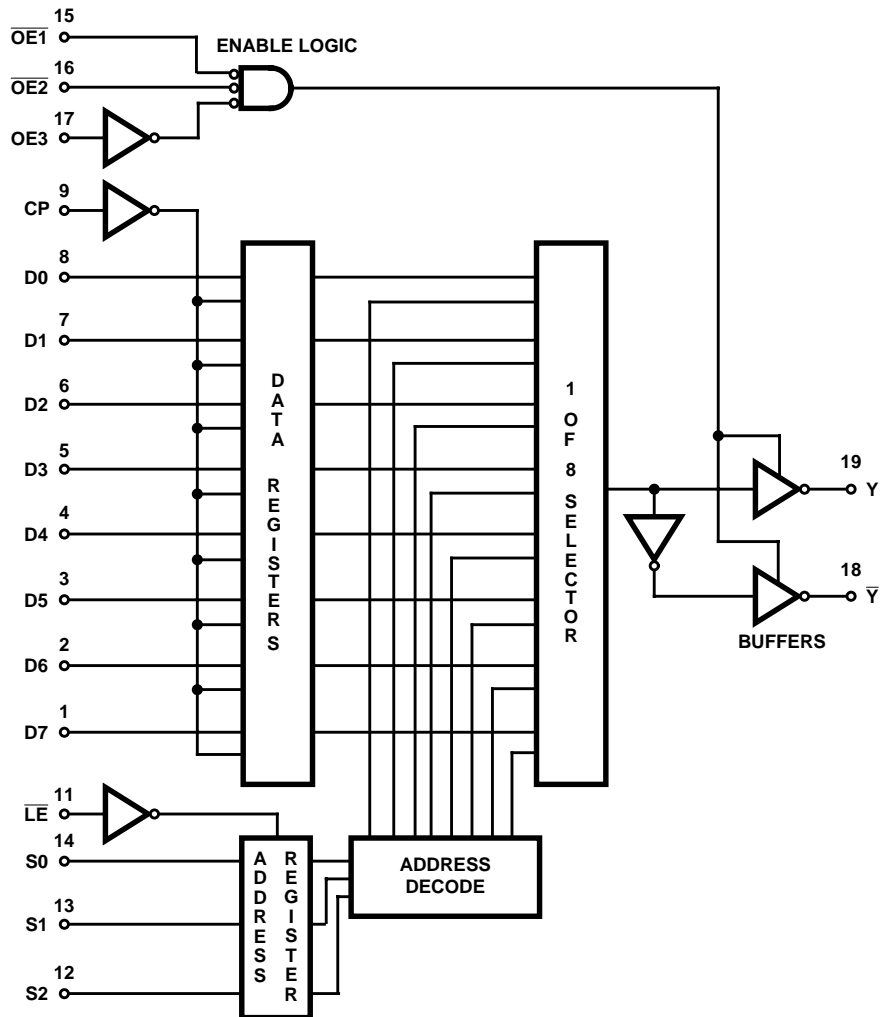

Logic Diagram

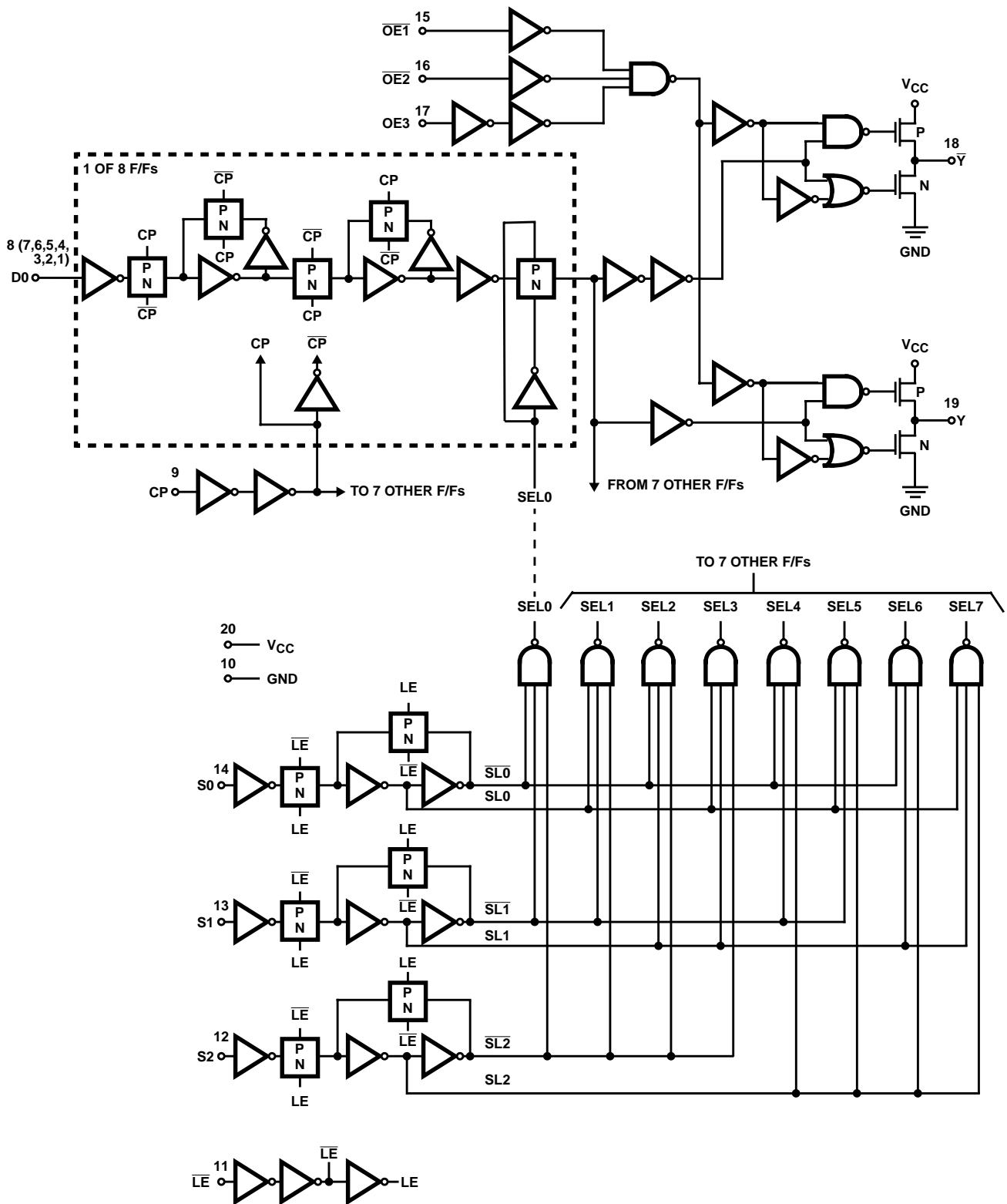

FIGURE 1. LOGIC DIAGRAM

CD74HCT356

Absolute Maximum Ratings

DC Supply Voltage, V_{CC}	-0.5V to 7V
DC Input Diode Current, I_{IK}	
For $V_I < -0.5V$ or $V_I > V_{CC} + 0.5V$	$\pm 20mA$
DC Output Diode Current, I_{OK}	
For $V_O < -0.5V$ or $V_O > V_{CC} + 0.5V$	$\pm 20mA$
DC Drain Current, per Output, I_O	
For $-0.5V < V_O < V_{CC} + 0.5V$	$\pm 35mA$
DC Output Source or Sink Current per Output Pin, I_O	
For $V_O > -0.5V$ or $V_O < V_{CC} + 0.5V$	$\pm 25mA$
DC V_{CC} or Ground Current, I_{CC}	$\pm 50mA$

Thermal Information

Thermal Resistance (Typical, Note 2)	θ_{JA} ($^{\circ}C/W$)
E (PDIP) Package	69
M (SOIC) Package	58
Maximum Junction Temperature	150 $^{\circ}C$
Maximum Storage Temperature Range	-65 $^{\circ}C$ to 150 $^{\circ}C$
Maximum Lead Temperature (Soldering 10s)	300 $^{\circ}C$ (SOIC - Lead Tips Only)

Operating Conditions

Temperature Range, T_A	-55 $^{\circ}C$ to 125 $^{\circ}C$
Supply Voltage Range, V_{CC}	4.5V to 5.5V
DC Input or Output Voltage, V_I, V_O	0V to V_{CC}
Input Rise and Fall Time	
2V	1000ns (Max)
4.5V	500ns (Max)
6V	400ns (Max)

CAUTION: Stresses above those listed in "Absolute Maximum Ratings" may cause permanent damage to the device. This is a stress only rating and operation of the device at these or any other conditions above those indicated in the operational sections of this specification is not implied.

NOTE:

- The package thermal impedance is calculated in accordance with JESD 51-7.

DC Electrical Specifications

PARAMETER	SYMBOL	TEST CONDITIONS		V_{CC} (V)	25 $^{\circ}C$			-40 $^{\circ}C$ TO 85 $^{\circ}C$		-55 $^{\circ}C$ TO 125 $^{\circ}C$		UNITS
		V_I (V)	I_O (mA)		MIN	TYP	MAX	MIN	MAX	MIN	MAX	
High Level Input Voltage	V_{IH}	-	-	4.5 to 5.5	2	-	-	2	-	2	-	V
Low Level Input Voltage	V_{IL}	-	-	4.5 to 5.5	-	-	0.8	-	0.8	-	0.8	V
High Level Output Voltage CMOS Loads	V_{OH}	V_{IH} or V_{IL}	-0.02	4.5	4.4	-	-	4.4	-	4.4	-	V
High Level Output Voltage TTL Loads			-4	4.5	3.98	-	-	3.84	-	3.7	-	V
Low Level Output Voltage CMOS Loads	V_{OL}	V_{IH} or V_{IL}	0.02	4.5	-	-	0.1	-	0.1	-	0.1	V
Low Level Output Voltage TTL Loads			4	4.5	-	-	0.26	-	0.33	-	0.4	V
Input Leakage Current	I_I	V_{CC} to GND	0	5.5	-	-	± 0.1	-	± 1	-	± 1	μA
Quiescent Device Current	I_{CC}	V_{CC} or GND	0	5.5	-	-	8	-	80	-	160	μA
Additional Quiescent Device Current Per Input Pin: 1 Unit Load	ΔI_{CC} (Note 3)	V_{CC} -2.1	-	4.5 to 5.5	-	100	360	-	450	-	490	μA
3-State Leakage Current	I_{OZ}	V_{IL} or V_{IH}	$V_O = V_{CC}$ or GND	5.5	-	-	± 0.5	-	± 5	-	± 10	μA

NOTE:

- For dual-supply systems theoretical worst case ($V_I = 2.4V$, $V_{CC} = 5.5V$) specification is 1.8mA.

CD74HCT356

Input Loading Table

INPUT	UNIT LOADS
D0-D7	0.50
S0, S1, S3	0.70
$\overline{OE1}$, $\overline{OE2}$	0.80
OE3	0.25
\overline{LE}	0.25
CP	0.60

NOTE: Unit Load is ΔI_{CC} limit specified in DC Electrical Specifications table, e.g., 360 μ A max at 25 $^{\circ}$ C.

Prerequisite For Switching Specifications

PARAMETER	SYMBOL	TEST CONDITIONS	V _{CC} (V)	25 $^{\circ}$ C			-40 $^{\circ}$ C TO 85 $^{\circ}$ C		-55 $^{\circ}$ C TO 125 $^{\circ}$ C		UNITS
				MIN	TYP	MAX	MIN	MAX	MIN	MAX	
CP Pulse Width	t_{PLH} , t_{PHL}	-	4.5	16	20	-	25	-	30	-	ns
\overline{LE} Pulse Width	t_{PLH} , t_{PHL}	-	4.5	16	20	-	25	-	30	-	ns
Setup Times Dn $\rightarrow \overline{E}$	t_{SU}	-	4.5	5	7	-	9	-	11	-	ns
Setup Times Sn $\rightarrow \overline{LE}$	t_{SU}	-	4.5	5	7	-	9	-	11	-	ns
Hold Times Dn $\rightarrow \overline{E}$	t_H	-	4.5	9	9	-	11	-	14	-	ns
Hold Times Sn $\rightarrow \overline{LE}$	t_H	-	4.5	12	12	-	15	-	18	-	ns

CD74HCT356

Switching Specifications Input $t_r, t_f = 6\text{ns}$

PARAMETER	SYMBOL	TEST CONDITIONS	V_{CC} (V)	25°C		-40°C TO 85°C	-55°C TO 125°C	UNITS	
				TYP	MAX	MAX	MAX		
Propagation Delay, $CP \rightarrow Y, \bar{Y}$	t_{PLH}, t_{PHL}	$C_L = 50\text{pF}$	4.5	-	51	64	77	ns	
		$C_L = 15\text{pF}$	5	22	-	-	-	ns	
Propagation Delay, $S_n \rightarrow Y, \bar{Y}$	t_{PLH}, t_{PHL}	$C_L = 50\text{pF}$	4.5	-	59	74	89	ns	
		$C_L = 15\text{pF}$	5	25	-	-	-	ns	
Propagation Delay, $\bar{L}\bar{E} \rightarrow Y, \bar{Y}$	t_{PLH}, t_{PHL}	$C_L = 50\text{pF}$	4.5	-	63	79	94	ns	
		$C_L = 15\text{pF}$	5	25	-	-	-	ns	
Output Disabling Time	t_{PLZ}, t_{PHZ}	$C_L = 50\text{pF}$	4.5	-	33	41	50	ns	
		t_{PLZ}	$C_L = 15\text{pF}$	5	13	-	-	-	ns
		t_{PHZ}	$C_L = 15\text{pF}$	5	15	-	-	-	ns
Output Enabling Time	t_{PLZ}, t_{PHZ}	$C_L = 50\text{pF}$	4.5	-	34	43	51	ns	
		$C_L = 15\text{pF}$	5	14	-	-	-	ns	
Output Transition Time	t_{TLH}, t_{THL}	$C_L = 50\text{pF}$	4.5	-	12	15	18	ns	
Input Capacitance	C_{IN}	-	-	-	10	10	10	pF	
3-State Capacitance	C_O	-	-	-	20	20	20	pF	
Power Dissipation Capacitance (Notes 4, 5)	C_{PD}	-	5	52	-	-	-	pF	

NOTES:

4. C_{PD} is used to determine the dynamic power consumption, per device.
5. $P_D = V_{CC}^2 (C_{PD} + C_L) f_i$ where f_i = Input Frequency, C_L = Output Load Capacitance, V_{CC} = Supply Voltage.

Test Circuits and Waveforms

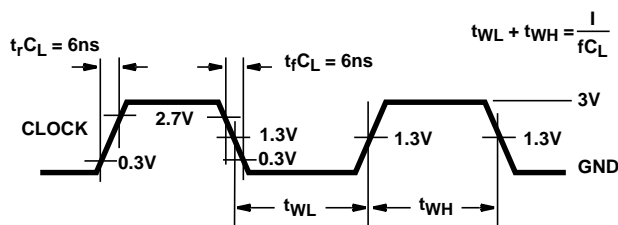

NOTE: Outputs should be switching from 10% V_{CC} to 90% V_{CC} in accordance with device truth table. For f_{MAX} , input duty cycle = 50%.

FIGURE 2. CLOCK PULSE RISE AND FALL TIMES AND PULSE WIDTH

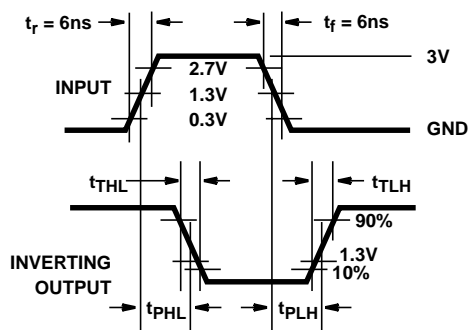

FIGURE 3. TRANSITION TIMES AND PROPAGATION-DELAY TIMES, COMBINATION LOGIC

Test Circuits and Waveforms (Continued)

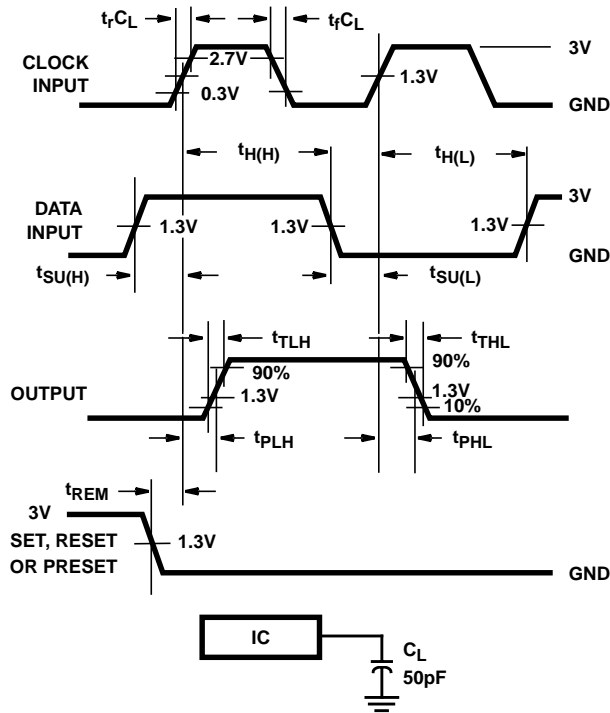

FIGURE 4. SETUP TIMES, HOLD TIMES, REMOVAL TIME, AND PROPAGATION-DELAY TIMES FOR EDGE TRIGGERED SEQUENTIAL LOGIC CIRCUITS

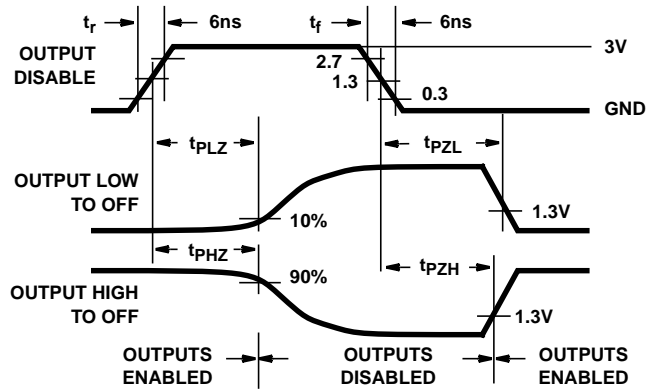
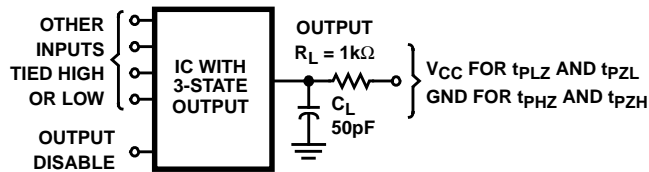

FIGURE 5. 3-STATE PROPAGATION-DELAY WAVEFORM



NOTE: Open-drain waveforms t_{PLZ} and t_{PZL} are the same as those for 3-state shown on the left. The test circuit is Output $R_L = 1k\Omega$ to V_{CC} , $C_L = 50pF$.

FIGURE 6. 3-STATE PROPAGATION-DELAY TEST CIRCUIT

PACKAGING INFORMATION

Orderable Device	Status ⁽¹⁾	Package Type	Package Drawing	Pins	Package Qty	Eco Plan ⁽²⁾	Lead/Ball Finish	MSL Peak Temp ⁽³⁾
CD74HCT356E	ACTIVE	PDIP	N	20	20	Pb-Free (RoHS)	CU NIPDAU	N / A for Pkg Type
CD74HCT356EE4	ACTIVE	PDIP	N	20	20	Pb-Free (RoHS)	CU NIPDAU	N / A for Pkg Type

⁽¹⁾ The marketing status values are defined as follows:

ACTIVE: Product device recommended for new designs.

LIFEBUY: TI has announced that the device will be discontinued, and a lifetime-buy period is in effect.

NRND: Not recommended for new designs. Device is in production to support existing customers, but TI does not recommend using this part in a new design.

PREVIEW: Device has been announced but is not in production. Samples may or may not be available.

OBsolete: TI has discontinued the production of the device.

⁽²⁾ Eco Plan - The planned eco-friendly classification: Pb-Free (RoHS), Pb-Free (RoHS Exempt), or Green (RoHS & no Sb/Br) - please check <http://www.ti.com/productcontent> for the latest availability information and additional product content details.

TBD: The Pb-Free/Green conversion plan has not been defined.

Pb-Free (RoHS): TI's terms "Lead-Free" or "Pb-Free" mean semiconductor products that are compatible with the current RoHS requirements for all 6 substances, including the requirement that lead not exceed 0.1% by weight in homogeneous materials. Where designed to be soldered at high temperatures, TI Pb-Free products are suitable for use in specified lead-free processes.

Pb-Free (RoHS Exempt): This component has a RoHS exemption for either 1) lead-based flip-chip solder bumps used between the die and package, or 2) lead-based die adhesive used between the die and leadframe. The component is otherwise considered Pb-Free (RoHS compatible) as defined above.

Green (RoHS & no Sb/Br): TI defines "Green" to mean Pb-Free (RoHS compatible), and free of Bromine (Br) and Antimony (Sb) based flame retardants (Br or Sb do not exceed 0.1% by weight in homogeneous material)

⁽³⁾ MSL, Peak Temp. -- The Moisture Sensitivity Level rating according to the JEDEC industry standard classifications, and peak solder temperature.

Important Information and Disclaimer: The information provided on this page represents TI's knowledge and belief as of the date that it is provided. TI bases its knowledge and belief on information provided by third parties, and makes no representation or warranty as to the accuracy of such information. Efforts are underway to better integrate information from third parties. TI has taken and continues to take reasonable steps to provide representative and accurate information but may not have conducted destructive testing or chemical analysis on incoming materials and chemicals. TI and TI suppliers consider certain information to be proprietary, and thus CAS numbers and other limited information may not be available for release.

In no event shall TI's liability arising out of such information exceed the total purchase price of the TI part(s) at issue in this document sold by TI to Customer on an annual basis.

N (R-PDIP-T**)

PLASTIC DUAL-IN-LINE PACKAGE

16 PINS SHOWN



- NOTES:
- A. All linear dimensions are in inches (millimeters).
 - B. This drawing is subject to change without notice.
 - Falls within JEDEC MS-001, except 18 and 20 pin minimum body length (Dim A).
 - The 20 pin end lead shoulder width is a vendor option, either half or full width.

IMPORTANT NOTICE

Texas Instruments Incorporated and its subsidiaries (TI) reserve the right to make corrections, modifications, enhancements, improvements, and other changes to its products and services at any time and to discontinue any product or service without notice. Customers should obtain the latest relevant information before placing orders and should verify that such information is current and complete. All products are sold subject to TI's terms and conditions of sale supplied at the time of order acknowledgment.

TI warrants performance of its hardware products to the specifications applicable at the time of sale in accordance with TI's standard warranty. Testing and other quality control techniques are used to the extent TI deems necessary to support this warranty. Except where mandated by government requirements, testing of all parameters of each product is not necessarily performed.

TI assumes no liability for applications assistance or customer product design. Customers are responsible for their products and applications using TI components. To minimize the risks associated with customer products and applications, customers should provide adequate design and operating safeguards.

TI does not warrant or represent that any license, either express or implied, is granted under any TI patent right, copyright, mask work right, or other TI intellectual property right relating to any combination, machine, or process in which TI products or services are used. Information published by TI regarding third-party products or services does not constitute a license from TI to use such products or services or a warranty or endorsement thereof. Use of such information may require a license from a third party under the patents or other intellectual property of the third party, or a license from TI under the patents or other intellectual property of TI.

Reproduction of TI information in TI data books or data sheets is permissible only if reproduction is without alteration and is accompanied by all associated warranties, conditions, limitations, and notices. Reproduction of this information with alteration is an unfair and deceptive business practice. TI is not responsible or liable for such altered documentation. Information of third parties may be subject to additional restrictions.

Resale of TI products or services with statements different from or beyond the parameters stated by TI for that product or service voids all express and any implied warranties for the associated TI product or service and is an unfair and deceptive business practice. TI is not responsible or liable for any such statements.

TI products are not authorized for use in safety-critical applications (such as life support) where a failure of the TI product would reasonably be expected to cause severe personal injury or death, unless officers of the parties have executed an agreement specifically governing such use. Buyers represent that they have all necessary expertise in the safety and regulatory ramifications of their applications, and acknowledge and agree that they are solely responsible for all legal, regulatory and safety-related requirements concerning their products and any use of TI products in such safety-critical applications, notwithstanding any applications-related information or support that may be provided by TI. Further, Buyers must fully indemnify TI and its representatives against any damages arising out of the use of TI products in such safety-critical applications.

TI products are neither designed nor intended for use in military/aerospace applications or environments unless the TI products are specifically designated by TI as military-grade or "enhanced plastic." Only products designated by TI as military-grade meet military specifications. Buyers acknowledge and agree that any such use of TI products which TI has not designated as military-grade is solely at the Buyer's risk, and that they are solely responsible for compliance with all legal and regulatory requirements in connection with such use.

TI products are neither designed nor intended for use in automotive applications or environments unless the specific TI products are designated by TI as compliant with ISO/TS 16949 requirements. Buyers acknowledge and agree that, if they use any non-designated products in automotive applications, TI will not be responsible for any failure to meet such requirements.

Following are URLs where you can obtain information on other Texas Instruments products and application solutions:

Products		Applications	
Amplifiers	amplifier.ti.com	Audio	www.ti.com/audio
Data Converters	dataconverter.ti.com	Automotive	www.ti.com/automotive
DLP® Products	www.dlp.com	Communications and Telecom	www.ti.com/communications
DSP	dsp.ti.com	Computers and Peripherals	www.ti.com/computers
Clocks and Timers	www.ti.com/clocks	Consumer Electronics	www.ti.com/consumer-apps
Interface	interface.ti.com	Energy	www.ti.com/energy
Logic	logic.ti.com	Industrial	www.ti.com/industrial
Power Mgmt	power.ti.com	Medical	www.ti.com/medical
Microcontrollers	microcontroller.ti.com	Security	www.ti.com/security
RFID	www.ti-rfid.com	Space, Avionics & Defense	www.ti.com/space-avionics-defense
RF/IF and ZigBee® Solutions	www.ti.com/lprf	Video and Imaging	www.ti.com/video
		Wireless	www.ti.com/wireless-apps

Mailing Address: Texas Instruments, Post Office Box 655303, Dallas, Texas 75265
Copyright © 2010, Texas Instruments Incorporated

Looking for pricing, stock, or lifecycle information?

Click below to explore more details on WIN SOURCE:

 [View CD74HCT356E](#) on WIN SOURCE

 [Texas Instruments](#) Information

Optimize Your Supply Chain with WIN SOURCE Solutions

-  Global Sourcing Solution
-  Obsolete Management
-  Cost Control Management
-  Shortage Management
-  Alternative Solution
-  Excess Inventory Management