



**THE DATASHEET OF
LM82CIMQA/NOPB**



LM82 Remote Diode and Local Digital Temperature Sensor with Two-Wire Interface

Check for Samples: [LM82](#)

FEATURES

- Accurately Senses Die Temperature of Remote ICs, or Diode Junctions
- On-board Local Temperature Sensing
- SMBus and I²C Compatible Interface, Supports SMBus 1.1 TIMEOUT
- Two Interrupt Outputs: $\overline{\text{INT}}$ and $\overline{\text{T_CRIT_A}}$
- Register Readback Capability
- 7 bit Plus Sign Temperature Data Format, 1°C Resolution
- 2 Address Select Pins Allow Connection of 9 LM82s on a Single Bus

APPLICATIONS

- System Thermal Management
- Computers
- Electronic Test Equipment
- Office Electronics
- HVAC

KEY SPECIFICATIONS

- Supply Voltage: 3.0 to 3.6V
- Supply Current: 0.8mA (max)
- Local Temp Accuracy (includes quantization error):
 - 0 to +85 ±3.0°C (max)
- Remote Diode Temp Accuracy (includes quantization error):
 - +25°C to +100°C ±3°C (max)
 - 0°C to +125°C ±4°C (max)

DESCRIPTION

The LM82 is a digital temperature sensor with a 2 wire serial interface that senses the voltage and thus the temperature of a remote diode using a Delta-Sigma analog-to-digital converter with a digital over-temperature detector. The LM82 accurately senses its own temperature as well as the temperature of external devices, such as Pentium II Processors or diode connected 2N3904s. The temperature of any ASIC can be detected using the LM82 as long as a dedicated diode (semiconductor junction) is available on the die. Using the SMBus interface a host can access the LM82's registers at any time. Activation of a $\overline{\text{T_CRIT_A}}$ output occurs when any temperature is greater than a programmable comparator limit, $\overline{\text{T_CRIT}}$. Activation of an $\overline{\text{INT}}$ output occurs when any temperature is greater than its corresponding programmable comparator HIGH limit.

The host can program as well as read back the state of the $\overline{\text{T_CRIT}}$ register and the 2 $\overline{\text{T_HIGH}}$ registers. Three state logic inputs allow two pins ($\overline{\text{ADD0}}$, $\overline{\text{ADD1}}$) to select up to 9 SMBus address locations for the LM82. The sensor powers up with default thresholds of 127°C for $\overline{\text{T_CRIT}}$ and all $\overline{\text{T_HIGH}}$ s. The LM82 is pin for pin and register compatible with the LM84, Maxim MAX1617 and Analog Devices ADM1021.



Please be aware that an important notice concerning availability, standard warranty, and use in critical applications of Texas Instruments semiconductor products and disclaimers thereto appears at the end of this data sheet.

All trademarks are the property of their respective owners.

Simplified Block Diagram

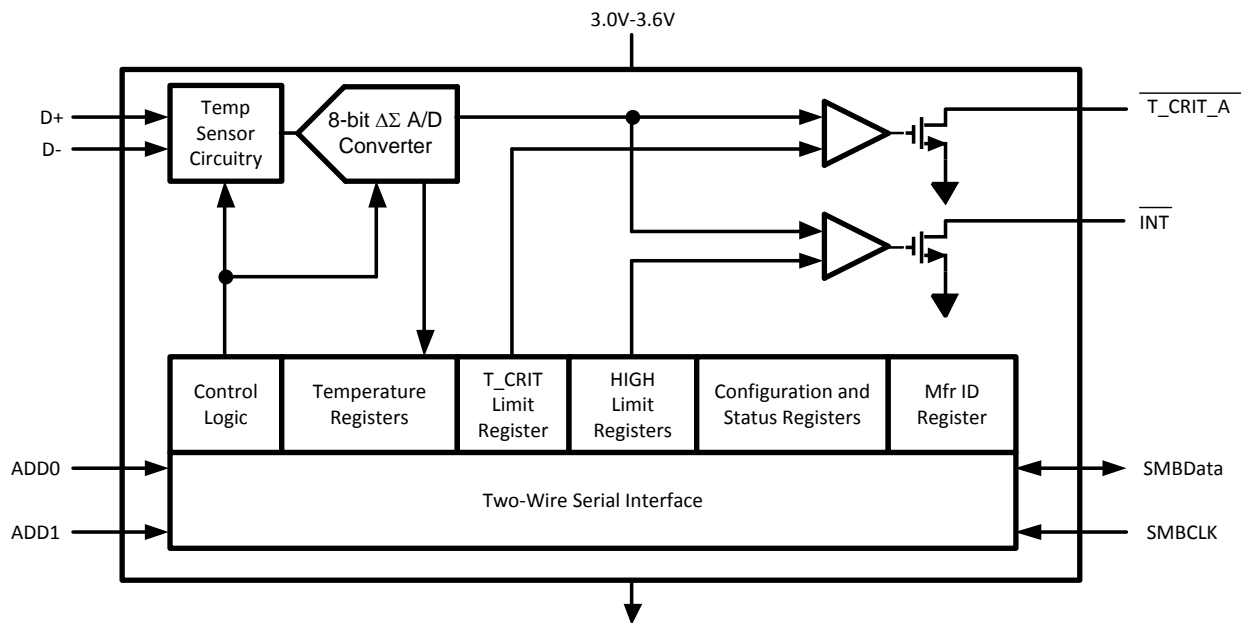

Connection Diagram

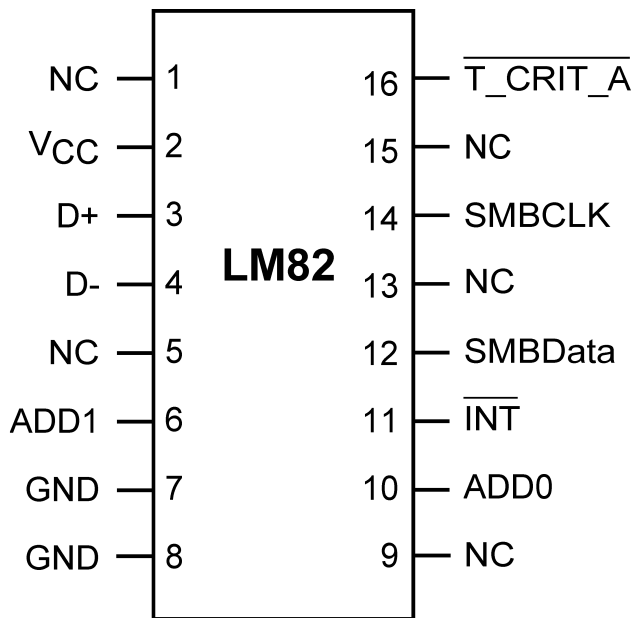
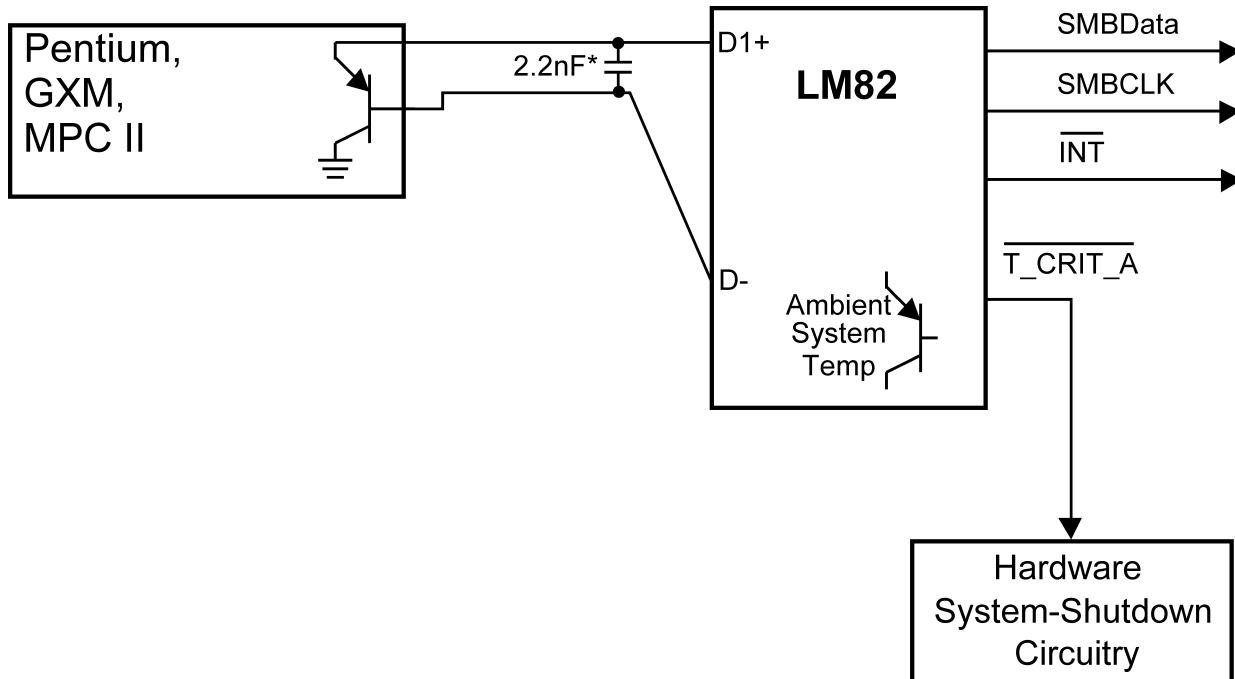

Figure 1. SSOP-TOP VIEW
See DBQ Package

Typical Application



*Note: 2.2nF Capacitors must be placed as close as possible to D+ and D- pins of the LM82.

PIN DESCRIPTIONS

Label	Pin #	Function	Typical Connection
NC	1, 5	floating, unconnected	Left floating. PC board traces may be routed through the pads for these pins. No restrictions applied.
V _{CC}	2	Positive Supply Voltage Input	DC Voltage from 3.0 V to 3.6 V
D+	3	Diode Current Source	To Diode Anode. Connected to remote discrete diode junction or to the diode junction on a remote IC whose die temperature is being sensed. When not used they should be left floating.
D-	4	Diode Return Current Sink	To Diode Cathode. Must float when not used.
ADD0–ADD1	10, 6	User-Set SMBus (I ² C) Address Inputs	Ground (Low, "0"), V _{CC} (High, "1") or open ("TRI-LEVEL")
GND	7, 8	Power Supply Ground	Ground
NC	9, 13, 15	Manufacturing test pins.	Left floating. PC board traces may be routed through the pads for these pins, although the components that drive these traces should share the same supply as the LM82 so that the Absolute Maximum Rating, Voltage at Any Pin, is not violated.
$\overline{\text{INT}}$	11	Interrupt Output, open-drain	Pull Up Resistor, Controller Interrupt or Alert Line
SMBData	12	SMBus (I ² C) Serial Bi-Directional Data Line, open-drain output	From and to Controller, Pull-Up Resistor
SMBCLK	14	SMBus (I ² C) Clock Input	From Controller, Pull-Up Resistor
$\overline{\text{T_CRIT_A}}$	16	Critical Temperature Alarm, open-drain output	Pull Up Resistor, Controller Interrupt Line or System Shutdown



These devices have limited built-in ESD protection. The leads should be shorted together or the device placed in conductive foam during storage or handling to prevent electrostatic damage to the MOS gates.

Absolute Maximum Ratings ⁽¹⁾

Supply Voltage	-0.3 V to 6.0 V	
Voltage at SMBData, SMBCLK, $\overline{T_CRIT_A}$ & \overline{INT} pins	-0.5V to 6V	
Voltage at Other Pins	-0.3 V to ($V_{CC} + 0.3$ V)	
D- Input Current	± 1 mA	
Input Current at All Other Pins ⁽²⁾	5 mA	
Package Input Current ⁽²⁾	20 mA	
SMBData, $\overline{T_CRIT_A}$, \overline{INT} Output Sink Current	10 mA	
Storage Temperature	-65°C to +150°C	
Soldering Information, Lead Temperature		
SSOP Package ⁽³⁾	Vapor Phase (60 seconds)	215°C
	Infrared (15 seconds)	220°C
ESD Susceptibility ⁽⁴⁾	Human Body Model	2000 V
	Machine Model	250 V

- (1) Absolute Maximum Ratings indicate limits beyond which damage to the device may occur. DC and AC electrical specifications do not apply when operating the device beyond its rated operating conditions.
- (2) When the input voltage (V_I) at any pin exceeds the power supplies ($V_I < GND$ or $V_I > V_{CC}$), the current at that pin should be limited to 5 mA. The 20 mA maximum package input current rating limits the number of pins that can safely exceed the power supplies with an input current of 5 mA to four. Parasitic components and or ESD protection circuitry are shown in the figure below for the LM82's pins. The nominal breakdown voltage of the zener D3 is 6.5 V. Care should be taken not to forward bias the parasitic diode, D1, present on pins: D+, D-, ADD1 and ADD0. Doing so by more than 50 mV may corrupt a temperature or voltage measurement.
- (3) See the section titled "Surface Mount" found in a current Texas Instruments Linear Data Book for other methods of soldering surface mount devices.
- (4) Human body model, 100 pF discharged through a 1.5 k Ω resistor. Machine model, 200 pF discharged directly into each pin.

Operating Ratings

Specified Temperature Range	T_{MIN} to T_{MAX}
LM82	-40°C to +125°C
Supply Voltage Range (V_{CC})	+3.0V to +3.6V

Temperature-to-Digital Converter Characteristics

Unless otherwise noted, these specifications apply for $V_{CC}=+3.0$ Vdc to 3.6 Vdc. **Boldface limits apply for $T_A = T_J = T_{MIN}$ to T_{MAX}** ; all other limits $T_A = T_J = +25^\circ\text{C}$, unless otherwise noted.

Parameter	Conditions	Typical ⁽¹⁾	Limits ⁽²⁾	Units (Limit)
Temperature Error using Local Diode ⁽³⁾	$T_A = 0^\circ\text{C}$ to $+85^\circ\text{C}$, $V_{CC}=+3.3\text{V}$	± 1	± 3	$^\circ\text{C}$ (max)
	$T_A = -40^\circ\text{C}$ to $+125^\circ\text{C}$, $V_{CC}=+3.3\text{V}$		± 4	$^\circ\text{C}$ (max)
Temperature Error using Remote Diode ⁽³⁾	$T_A = +60^\circ\text{C}$ to $+100^\circ\text{C}$, $V_{CC}=+3.3\text{V}$		± 3	$^\circ\text{C}$ (max)
	$T_A = 0^\circ\text{C}$ to $+100^\circ\text{C}$, $V_{CC}=+3.3\text{V}$		± 3	$^\circ\text{C}$ (max)
	$T_A = 0^\circ\text{C}$ to $+125^\circ\text{C}$, $V_{CC}=+3.3\text{V}$		± 4	$^\circ\text{C}$ (max)
Resolution		8		Bits
		1		$^\circ\text{C}$

- (1) Typicals are at $T_A = 25^\circ\text{C}$ and represent most likely parametric norm.
- (2) Limits are ensured to AOQL (Average Outgoing Quality Level).
- (3) The Temperature Error will vary less than $\pm 1.0^\circ\text{C}$ for a variation in V_{CC} of 3V to 3.6V from the nominal of 3.3V.

Temperature-to-Digital Converter Characteristics (continued)

Unless otherwise noted, these specifications apply for $V_{CC}=+3.0$ Vdc to 3.6 Vdc. **Boldface limits apply for $T_A = T_J = T_{MIN}$ to T_{MAX}** ; all other limits $T_A = T_J = +25^\circ\text{C}$, unless otherwise noted.

Parameter	Conditions	Typical ⁽¹⁾	Limits ⁽²⁾	Units (Limit)
Conversion Time of All Temperatures	⁽⁴⁾	460	600	ms (max)
Quiescent Current ⁽⁵⁾	SMBus (I ² C) Inactive	0.500	0.80	mA (max)
D- Source Voltage		0.7		V
Diode Source Current	(D+ - D-) = + 0.65V; high level		125	μA (max)
			60	μA (min)
	Low level		15	μA (max)
			5	μA (min)
T_CRIT_A and INT Output Saturation Voltage	I _{OUT} = 3.0 mA		0.4	V (max)
Power-On Reset Threshold	On V _{CC} input, falling edge		2.3	V (max)
			1.8	V (min)
Local and Remote T_CRIT and HIGH Default Temperature settings	See ⁽⁶⁾	+127		°C

(4) This specification is provided only to indicate how often temperature data is updated. The LM82 can be read at any time without regard to conversion state (and will yield last conversion result).

(5) Quiescent current will not increase substantially with an active SMBus.

(6) Default values set at power up.

Logic Electrical Characteristics- DIGITAL DC CHARACTERISTICS

Unless otherwise noted, these specifications apply for $V_{CC}=+3.0$ to 3.6 Vdc. **Boldface limits apply for $T_A = T_J = T_{MIN}$ to T_{MAX}** ; all other limits $T_A = T_J = +25^\circ\text{C}$, unless otherwise noted.

Symbol	Parameter	Conditions	Typical ⁽¹⁾	Limits ⁽²⁾	Units (Limit)
SMBData, SMBCLK					
V _{IN(1)}	Logical "1" Input Voltage			2.1	V (min)
V _{IN(0)}	Logical "0" Input Voltage			0.8	V (max)
V _{IN(HYST)}	SMBData and SMBCLK Digital Input Hysteresis		300		mV
I _{IN(1)}	Logical "1" Input Current	V _{IN} = V _{CC}	0.005	1.5	μA (max)
I _{IN(0)}	Logical "0" Input Current	V _{IN} = 0 V	-0.005	1.5	μA (max)
ADD0, ADD1					
V _{IN(1)}	Logical "1" Input Voltage		V _{CC}	1.5	V (min)
V _{IN(0)}	Logical "0" Input Voltage		GND	0.6	V (max)
I _{IN(1)}	Logical "1" Input Current	V _{IN} = V _{CC}		2	μA (max)
I _{IN(0)}	Logical "0" Input Current	V _{IN} = 0 V		-2	μA (max)
ALL DIGITAL INPUTS					
C _{IN}	Input Capacitance		20		pF
ALL DIGITAL OUTPUTS					
I _{OH}	High Level Output Current	V _{OH} = V _{CC}		100	μA (max)
V _{OL}	SMBus Low Level Output Voltage	I _{OL} = 3 mA I _{OL} = 6 mA		0.4	V (max)
				0.6	

(1) Typicals are at $T_A = 25^\circ\text{C}$ and represent most likely parametric norm.

(2) Limits are ensured to AOQL (Average Outgoing Quality Level).

Logic Electrical Characteristics- SMBus DIGITAL SWITCHING CHARACTERISTICS

Unless otherwise noted, these specifications apply for $V_{CC}=+3.0$ Vdc to $+3.6$ Vdc, C_L (load capacitance) on output lines = 80 pF. **Boldface limits apply for $T_A = T_J = T_{MIN}$ to T_{MAX}** ; all other limits $T_A = T_J = +25^\circ\text{C}$, unless otherwise noted.

The switching characteristics of the LM82 fully meet or exceed the published specifications of the SMBus or I²C bus. The following parameters are the timing relationships between SMBCLK and SMBData signals related to the LM82. They are not the I²C or SMBus bus specifications.

Symbol	Parameter	Conditions	Typical ⁽¹⁾	Limits ⁽²⁾	Units (Limit)
f_{SMB}	SMBus Clock Frequency			100 10	kHz (max) kHz (min)
t_{LOW}	SMBus Clock Low Time	10 % to 10 %		1.3 25	μs (min) ms (max)
$t_{LOWMEXT}$	Cumulative Clock Low Extend Time			10	ms (max)
t_{HIGH}	SMBus Clock High Time	90 % to 90%		0.6	μs (min)
$t_{R,SMB}$	SMBus Rise Time	10% to 90%	1		μs (max)
$t_{F,SMB}$	SMBus Fall Time	90% to 10%	0.3		ns (max)
t_{OF}	Output Fall Time	$C_L = 400$ pF, $I_O = 3$ mA		250	ns (max)
$t_{TIMEOUT}$	SMBData and SMBCLK Time Low for Reset of Serial Interface ⁽³⁾			25 40	ms (min) ms (max)
t_1	SMBCLK (Clock) Period			10	μs (min)
$t_2, t_{SU,DAT}$	Data In Setup Time to SMBCLK High			100	ns (min)
$t_3, t_{HD,DAT}$	Data Out Stable after SMBCLK Low			300 TBD	ns (min) ns (max)
$t_4, t_{HD,STA}$	SMBData Low Setup Time to SMBCLK Low			100	ns (min)
$t_5, t_{SU,STO}$	SMBData High Delay Time after SMBCLK High (Stop Condition Setup)			100	ns (min)
$t_6, t_{SU,STA}$	SMBus Start-Condition Setup Time			0.6	μs (min)
t_{BUF}	SMBus Free Time			1.3	μs (min)

(1) Typicals are at $T_A = 25^\circ\text{C}$ and represent most likely parametric norm.

(2) Limits are ensured to AOQL (Average Outgoing Quality Level).

(3) Holding the SMBData and/or SMBCLK lines Low for a time interval greater than $t_{TIMEOUT}$ will cause the LM82 to reset SMBData and SMBCLK to the IDLE state of an SMBus communication (SMBCLK and SMBData set High).

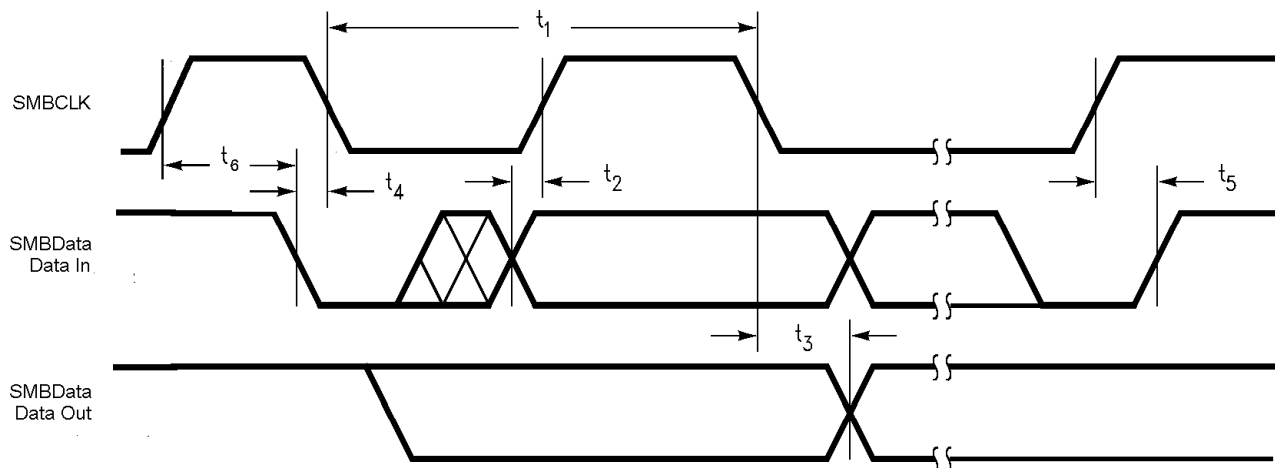

Figure 2. SMBus Communication

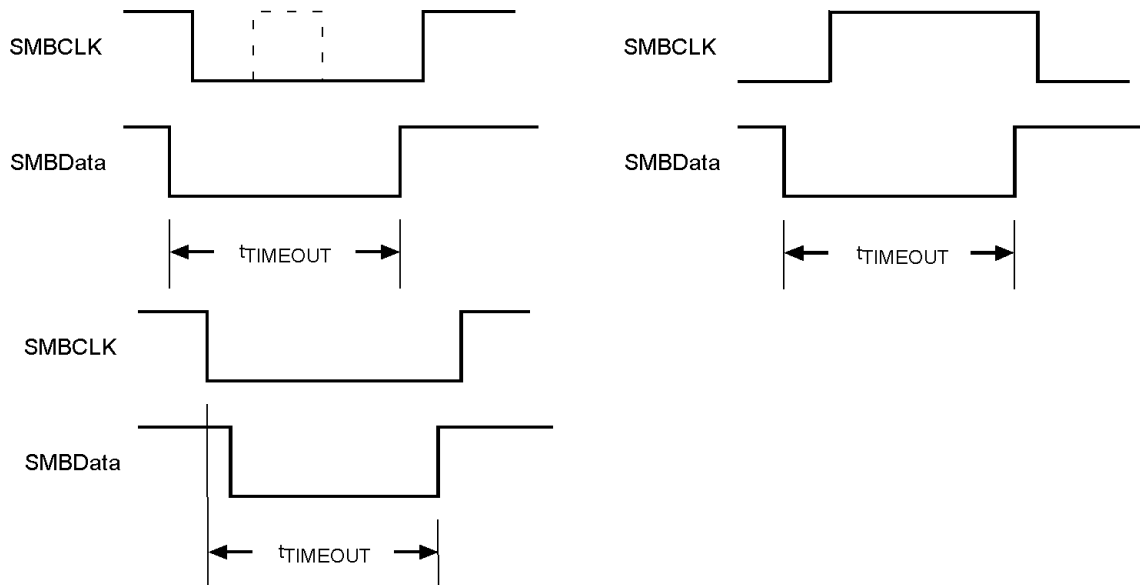

Figure 3. SMBus TIMEOUT

Pin Name	D1	D2	D3	D4	Pin Name	D1	D2	D3	D4
NC (pins 1 & 5)					$\overline{T_CRIT_A}$ & \overline{INT}		x		
V _{CC}			x ⁽¹⁾		SMBData		x	x	
D+	x	x	x		NC (pins 9 & 15)	x	x	x	
D-	x	x	x	x	SMBCLK		x	x	
ADD0, ADD1	x	x	x		NC (pin 13)		x	x	

(1) Note: An x indicates that the diode exists.

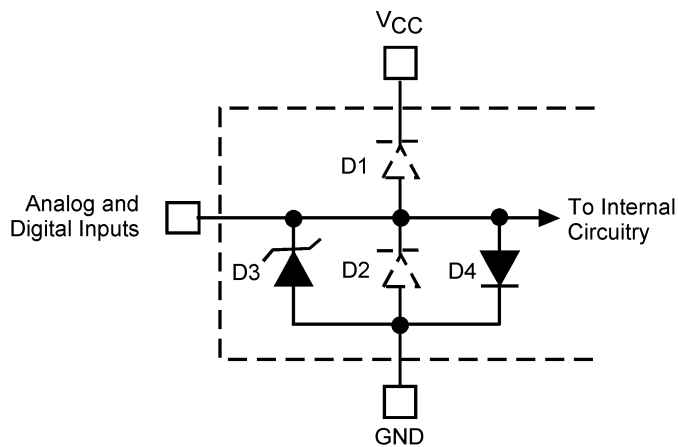

Figure 4. ESD Protection Input Structure

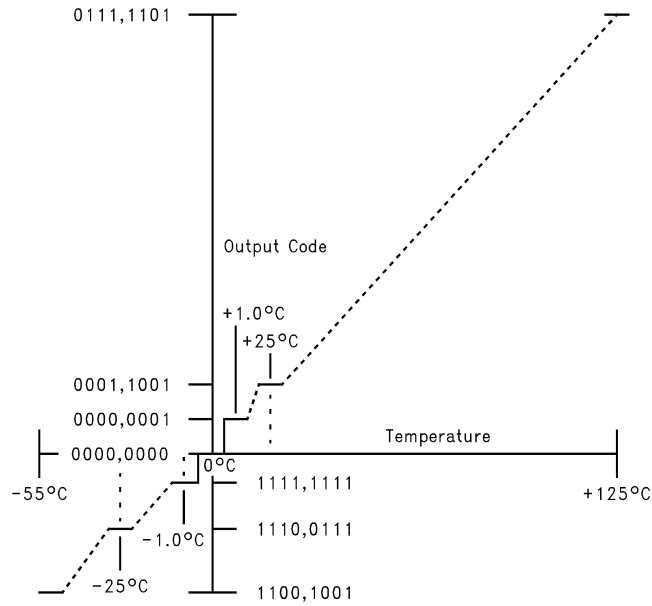

Figure 5. Temperature-to-Digital Transfer Function (Non-linear scale for clarity)

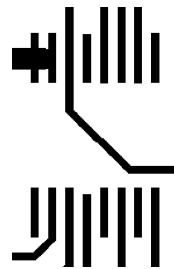

Figure 6. Printed Circuit Board Used for Thermal Resistance Specifications

FUNCTIONAL DESCRIPTION

The LM82 temperature sensor incorporates a band-gap type temperature sensor using a Local or Remote diode and an 8-bit ADC (Delta-Sigma Analog-to-Digital Converter). The LM82 is compatible with the serial SMBus and I²C two wire interfaces. Digital comparators compare Local (LT) and Remote (RT) temperature readings to user-programmable setpoints (LHS, RHS, and TCS). Activation of the INT output indicates that a comparison is greater than the limit preset in a HIGH register. The T_CRIT setpoint (TCS) interacts with all the temperature readings. Activation of the $\overline{T_CRIT_A}$ output indicates that any or all of the temperature readings have exceeded the T_CRIT setpoint.

CONVERSION SEQUENCE

The LM82 converts its own temperature as well as a remote diode temperature in the following sequence:

1. Local Temperature (LT)
2. Remote Diode (RT)

This round robin sequence takes approximately 480 ms to complete.

INT OUTPUT and T_HIGH LIMITS

Each temperature reading (LT, and RT) is associated with a T_HIGH setpoint register (LHS, RHS). At the end of a temperature reading a digital comparison determines whether that reading has exceeded its HIGH setpoint. If the temperature reading is greater than the HIGH setpoint, a bit is set in one of the Status Registers, to indicate which temperature reading, and the INT output is activated.

Local and remote temperature diodes are sampled in sequence by the A/D converter. The \overline{INT} output and the Status Register flags are updated at the completion of a conversion, which occurs approximately 60 ms after a temperature diode is sampled. \overline{INT} is deactivated when the Status Register, containing the set bit, is read and a temperature reading is less than or equal to its corresponding HIGH setpoint, as shown in Figure 7. Figure 8 shows a simplified logic diagram for the INT output and related circuitry.

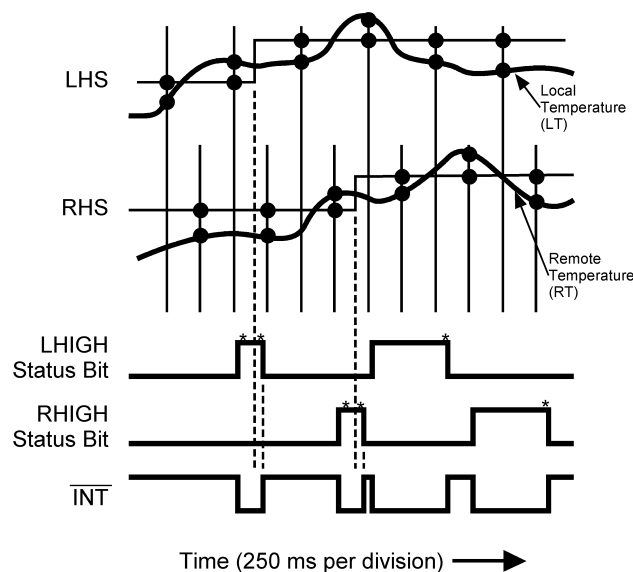

* Note: Status Register Bits are reset by a read of Status Register where bit is located.

Figure 7. \overline{INT} Temperature Response Diagram

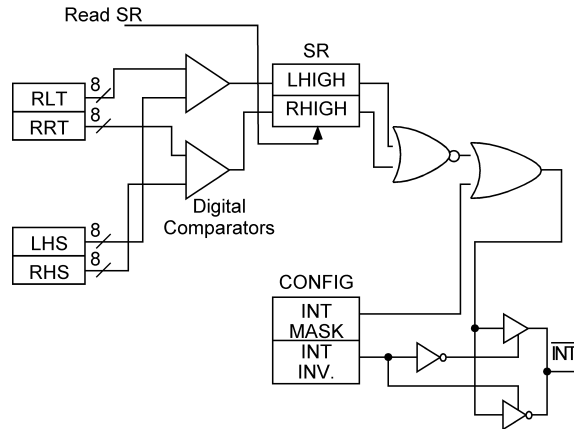

Figure 8. $\overline{\text{INT}}$ output related circuitry logic diagram

The $\overline{\text{INT}}$ output can be disabled by setting the $\overline{\text{INT}}$ mask bit, D7, of the configuration register. $\overline{\text{INT}}$ can be programmed to be active high or low by the state of the $\overline{\text{INT}}$ inversion bit, D1, in the configuration register. A “0” would program $\overline{\text{INT}}$ to be active low. $\overline{\text{INT}}$ is an open-drain output.

$\overline{\text{T_CRIT_A}}$ OUTPUT and T_CRIT LIMIT

$\overline{\text{T_CRIT_A}}$ is activated when any temperature reading is greater than the limit preset in the critical temperature setpoint register (T_CRIT), as shown in Figure 9. The Status Registers can be read to determine which event caused the alarm. A bit in the Status Registers is set high to indicate which temperature reading exceeded the T_CRIT setpoint temperature and caused the alarm, see STATUS REGISTER.

Local and remote temperature diodes are sampled in sequence by the A/D converter. The $\overline{\text{T_CRIT_A}}$ output and the Status Register flags are updated at the completion of a conversion. $\overline{\text{T_CRIT_A}}$ and the Status Register flags are reset only after the Status Register is read and if a temperature conversion is below the T_CRIT setpoint, as shown in Figure 9. Figure 10 shows a simplified logic diagram of the $\overline{\text{T_CRIT_A}}$ and related circuitry.

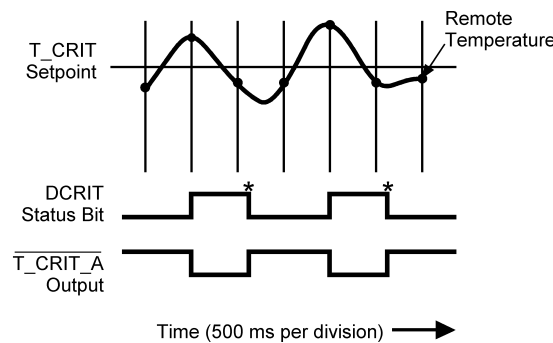

* Note: Status Register Bits are reset by a read of Status Register where bit is located.

Figure 9. $\overline{\text{T_CRIT_A}}$ Temperature Response Diagram

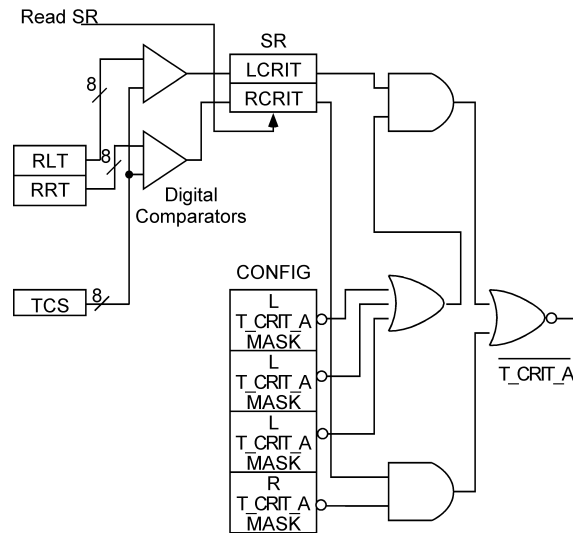

Figure 10. $\overline{T_CRIT_A}$ output related circuitry logic diagram

Located in the Configuration Register are the mask bits for each temperature reading, see [CONFIGURATION REGISTER](#). When a mask bit is set, its corresponding status flag will not propagate to the $\overline{T_CRIT_A}$ output, but will still be set in the Status Registers. Configuration register bits D5 and D3, labeled “Remote $\overline{T_CRIT_A}$ mask” must be set high before the $\overline{T_CRIT}$ setpoint is lowered in order for the $\overline{T_CRIT_A}$ output to function properly. Setting all four mask bits or programming the $\overline{T_CRIT}$ setpoint to 127°C will disable the $\overline{T_CRIT_A}$ output.

POWER ON RESET DEFAULT STATES

LM82 always powers up to these known default states:

1. Command Register set to 00h
2. Local Temperature set to 0°C
3. Remote Temperature set to 0°C until the LM82 senses a diode present between the D+ and D- input pins.
4. Status Register set to 00h.
5. Configuration Register set to 00h; \overline{INT} enabled and all $\overline{T_CRIT}$ setpoints enabled to activate $\overline{T_CRIT_A}$.
6. Local and Remote $\overline{T_CRIT}$ set to 127°C

SMBus INTERFACE

The LM82 operates as a slave on the SMBus, so the SMBCLK line is an input (no clock is generated by the LM82) and the SMBData line is bi-directional. According to SMBus specifications, the LM82 has a 7-bit slave address. Bit 4 (A3) of the slave address is hard wired inside the LM82 to a 1. The remainder of the address bits are controlled by the state of the address select pins ADD1 and ADD0, and are set by connecting these pins to ground for a low, (0), to V_{CC} for a high, (1), or left floating (TRI-LEVEL).

Therefore, the complete slave address is:

A6	A5	A4	1	A2	A1	A0
MSB						LSB

and is selected as follows:

Address Select Pin State		LM82 SMBus Slave Address
ADD0	ADD1	A6:A0 binary
0	0	001 1000
0	TRI-LEVEL	001 1001

Address Select Pin State		LM82 SMBus Slave Address
ADD0	ADD1	A6:A0 binary
0	1	001 1010
TRI-LEVEL	0	010 1001
TRI-LEVEL	TRI-LEVEL	010 1010
TRI-LEVEL	1	010 1011
1	0	100 1100
1	TRI-LEVEL	100 1101
1	1	100 1110

The LM82 latches the state of the address select pins during the first read or write on the SMBus. Changing the state of the address select pins after the first read or write to any device on the SMBus will not change the slave address of the LM82.

TEMPERATURE DATA FORMAT

Temperature data can be read from the Local and Remote Temperature, T_CRIT, and HIGH setpoint registers; and written to the T_CRIT and HIGH setpoint registers. Temperature data is represented by an 8-bit, two's complement byte with an LSB (Least Significant Bit) equal to 1°C:

Temperature	Digital Output	
	Binary	Hex
+125°C	0111 1101	7Dh
+25°C	0001 1001	19h
+1°C	0000 0001	01h
0°C	0000 0000	00h
-1°C	1111 1111	FFh
-25°C	1110 0111	E7h
-55°C	1100 1001	C9h

OPEN-DRAIN OUTPUTS

The SMBData, $\overline{\text{INT}}$ and $\overline{\text{T_CRIT_A}}$ outputs are open-drain outputs and do not have internal pull-ups. A “high” level will not be observed on these pins until pull-up current is provided from some external source, typically a pull-up resistor. Choice of resistor value depends on many system factors but, in general, the pull-up resistor should be as large as possible. This will minimize any internal temperature reading errors due to internal heating of the LM82. The maximum resistance of the pull up, based on LM82 specification for High Level Output Current, to provide a 2.1V high level, is 30kΩ. Care should be taken in a noisy system because a high impedance pull-up will be more likely to couple noise into the signal line.

DIODE FAULT DETECTION

Before each external conversion the LM82 goes through an external diode fault detection sequence. If D+ input is shorted to V_{CC} or floating then the temperature reading will be +127 °C, and the OPEN bit in the Status Register will be set. If the T_CRIT setpoint is set to less than +127 °C then the D+ input RTCRIT bit in the Status Register will be set which will activate the $\overline{\text{T_CRIT_A}}$ output, if enabled. If a D+ is shorted to GND or D-, its temperature reading will be 0 °C and its OPEN bit in the Status Register will not be set.

COMMUNICATING with the LM82

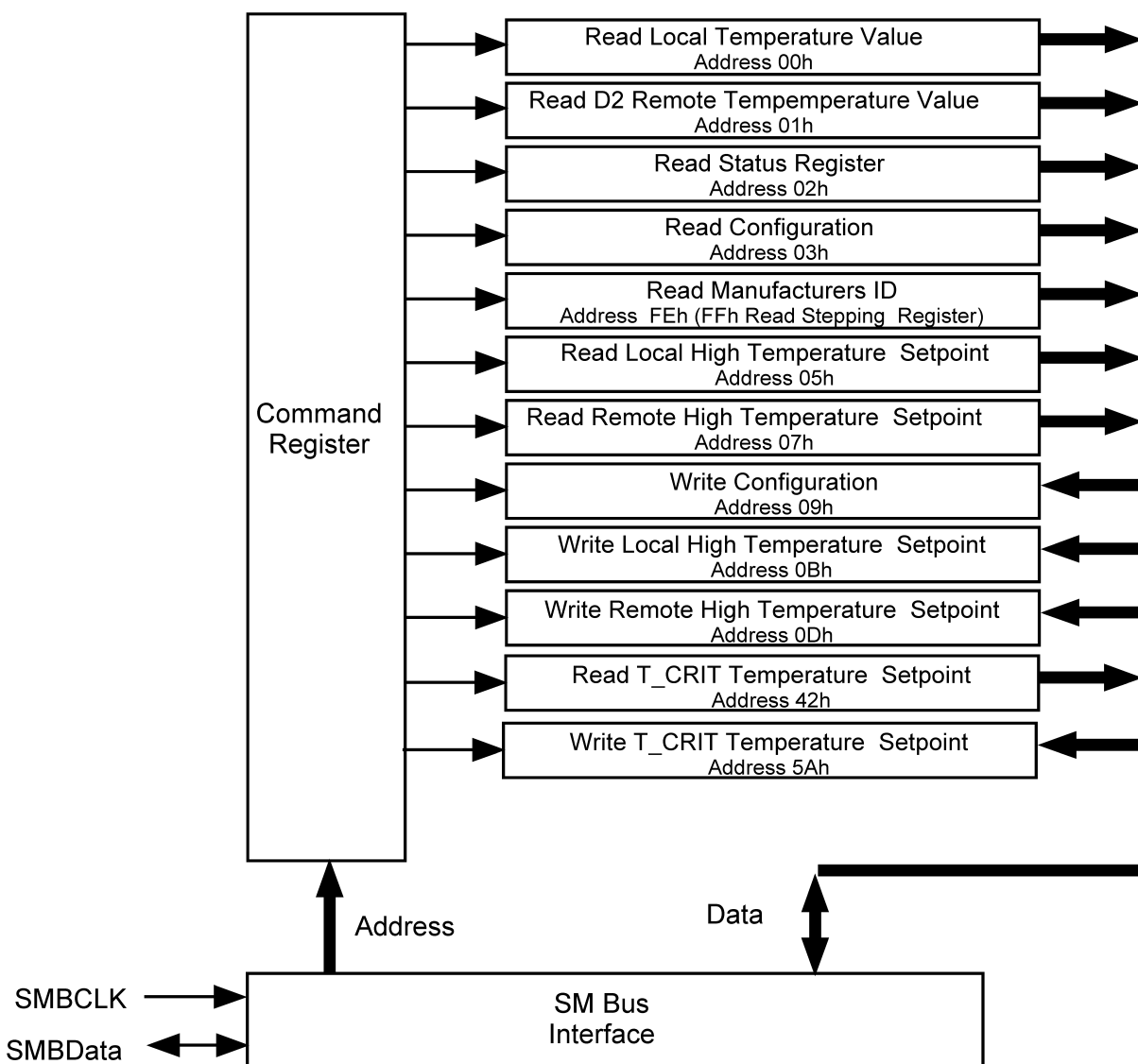

There are 13 data registers in the LM82, selected by the Command Register. At power-up the Command Register is set to "00", the location for the Read Local Temperature Register. The Command Register latches the last location it was set to. Reading the Status Register resets T_CRIT_A and INT, so long as a temperature comparison does not signal a fault (see [INT OUTPUT and T_HIGH LIMITS](#) and [T_CRIT_A OUTPUT and T_CRIT LIMIT](#)). All other registers are predefined as read only or write only. Read and write registers with the same function contain mirrored data.

A **Write** to the LM82 will always include the address byte and the command byte. A write to any register requires one data byte.

Reading the LM82 can take place either of two ways:

1. If the location latched in the Command Register is correct (most of the time it is expected that the Command Register will point to one of the Read Temperature Registers because that will be the data most frequently read from the LM82), then the read can simply consist of an address byte, followed by retrieving the data byte.
2. If the Command Register needs to be set, then an address byte, command byte, repeat start, and another address byte will accomplish a read.

The data byte has the most significant bit first. At the end of a read, the LM82 can accept either Acknowledge or No Acknowledge from the Master (No Acknowledge is typically used as a signal for the slave that the Master has read its last byte).

SERIAL INTERFACE ERROR RECOVERY

The LM82 SMBus lines will be reset to the SMBus idle state if the SMBData or SMBCLK lines are held low for 40 ms or more (t_{TIMEOUT}). The LM82 may or may not reset the state of the serial interface logic if either of the SMBData or SMBCLK lines are held low between 25 ms and 40 ms. TIMEOUT allows a clean recovery in cases where the master may be reset while the LM82 is transmitting a low bit thus preventing possible bus lock up.

Whenever the LM82 sees the start condition its serial interface will reset to the beginning of the communication, thus the LM82 will expect to see an address byte next. This simplifies recovery when the master is reset while the LM82 is transmitting a high.

LM82 Registers

COMMAND REGISTER

Selects which registers will be read from or written to. Data for this register should be transmitted during the Command Byte of the SMBus write communication.

P7	P6	P5	P4	P3	P2	P1	P0
0	Command Select						

P0-P7: Command Select

Command Select Address	Power On Default State		Register Name	Register Function
	<D7:D0> binary	<D7:D0> decimal		
00h	0000 0000	0	RLT	Read Local Temperature
01h	0000 0000	0	RRT	Read Remote Temperature
02h	0000 0000	0	RSR	Read Status Register
03h	0000 0000	0	RC	Read Configuration
04h	0000 0000	0		Reserved
05h	0111 1111	127	RLHS	Read Local HIGH Setpoint
06h				Reserved
07h	0111 1111	127	RRHS	Read Remote HIGH Setpoint
08h				Reserved
09h	0000 0000		WC	Write Configuration
0Ah				Reserved
0Bh	0111 1111	127	WLHS	Write Local HIGH Setpoint
0Ch				Reserved
0Dh	0111 1111	127	WRHS	Write Remote HIGH Setpoint
0Eh-2Fh				Reserved for Future Use
30h-31h	0000 0000	0		Reserved
32h-34h				Reserved for Future Use
35h	0000 0000	0		Reserved
36h-37h				Reserved for Future Use
38h	0111 1111	127		Reserved
39h				Reserved for Future Use
3Ah	0111 1111	127		Reserved
3Bh-41h				Reserved for Future Use
42h	0111 1111	127	RTCS	Read T_CRIT Setpoint
43h-4Fh				Reserved for Future Use

Command Select Address	Power On Default State		Register Name	Register Function
	<D7:D0> binary	<D7:D0> decimal		
<P7:P0> hex				
50h	0111 1111	127		Reserved
51h				Reserved for Future Use
52h	0111 1111	127		Reserved
53h-59h				Reserved for Future Use
5Ah	0111 1111	127	WTCS	Write T_CRIT Setpoint
5Ch-6Fh and F0h-FDh				Reserved for Future Use
FEh	0000 0001	1	RMID	Read Manufacturers ID
FFh	0000 0011	3	RSR	Read Stepping or Die Revision Code

LOCAL and REMOTE TEMPERATURE REGISTERS (LT, and RT)

Table 1. LOCAL and REMOTE TEMPERATURE REGISTERS (LT, and RT) (Read Only Address 00h, and 01h):

D7	D6	D5	D4	D3	D2	D1	D0
MSB	Bit 6	Bit 5	Bit 4	Bit 3	Bit 2	Bit 1	LSB

D7–D0: Temperature Data. One LSB = 1°C. Two's complement format.

STATUS REGISTER

Table 2. STATUS REGISTER (Read Only Address 02h):

D7	D6	D5	D4	D3	D2	D1	D0
0	LHIGH	0	RHIGH	0	OPEN	RCRIT	LCRIT

Power up default is with all bits “0” (zero).

D0: LCRIT: When set to a 1 indicates an Local Critical Temperature alarm.

D1: RCRIT: When set to a 1 indicates a Remote Diode Critical Temperature alarm.

D2: D2OPEN: When set to 1 indicates a Remote Diode disconnect.

D4: D2RHIGH: When set to 1 indicates a Remote Diode HIGH Temperature alarm.

D6: LHIGH: When set to 1 indicates a Local HIGH Temperature alarm.

D7, D5, and D3: These bits are always set to 0 and reserved for future use.

MANUFACTURERS ID AND DIE REVISION (Stepping) REGISTERS

MANUFACTURERS ID AND DIE REVISION (Stepping) REGISTERS (Read Address FEh and FFh) Default value 01h for Manufacturers ID(FEh).

CONFIGURATION REGISTER

Table 3. CONFIGURATION REGISTER (Read Address 03h/Write Address 09h):

D7	D6	D5	D4	D3	D2	D1	D0
$\overline{\text{INT}}$ mask	0	Remote T_CRIT_A mask	Remote T_CRIT_A mask	Remote T_CRIT_A mask	Local T_CRIT_A mask	$\overline{\text{INT}}$ Inversion	0

Power up default is with all bits “0” (zero).

D7: $\overline{\text{INT}}$ mask: When set to 1 $\overline{\text{INT}}$ interrupts are masked.

D5: T_CRIT mask, this bit must be set to a 1 before the T_CRIT setpoint is lowered below 127 in order for T_CRIT_A pin to function properly.

D4: T_CRIT mask for Remote temperature, when set to 1 a remote temperature reading that exceeds T_CRIT setpoint will not activate the $\overline{T_CRIT_A}$ pin.

D3: T_CRIT mask, this bit must be set to a 1 before the T_CRIT setpoint is lowered below 127 in order for $\overline{T_CRIT_A}$ pin to function properly.

D2: T_CRIT mask for Local reading, when set to 1 a Local temperature reading that exceeds T_CRIT setpoint will not activate the $\overline{T_CRIT_A}$ pin.

D1: \overline{INT} active state inversion. When \overline{INT} Inversion is set to a 1 the active state of the \overline{INT} output will be a logical high. A low would then select an active state of a logical low.

D6 and D0: These bits are always set to 0 and reserved for future use. A write of 1 will return a 0 when read.

LOCAL AND REMOTE HIGH SETPOINT REGISTERS (LHS, RHS)

Table 4. LOCAL AND REMOTE HIGH SETPOINT REGISTERS (LHS, RHS) (Read Address 05h, 07h/Write Address 0Bh, 0Dh):

D7	D6	D5	D4	D3	D2	D1	D0
MSB	Bit 6	Bit 5	Bit 4	Bit 3	Bit 2	Bit 1	LSB

D7–D0: HIGH setpoint temperature data. Power up default is LHIGH = RHIGH=127°C.

T_CRIT REGISTER (TCS)

Table 5. T_CRIT REGISTER (TCS) (Read Address 42h/Write Address 5Ah):

D7	D6	D5	D4	D3	D2	D1	D0
MSB	Bit 6	Bit 5	Bit 4	Bit 3	Bit 2	Bit 1	LSB

D7–D0: T_CRIT setpoint temperature data. Power up default is T_CRIT = 127°C.

SMBus Timing Diagrams

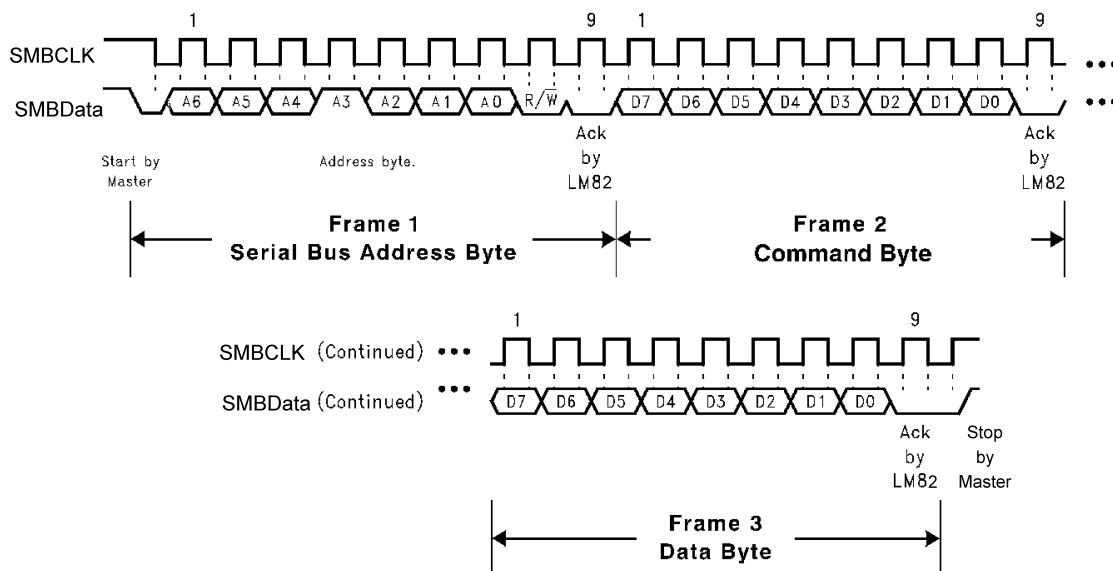

Figure 11. (a) Serial Bus Write to the internal Command Register followed by a the Data Byte

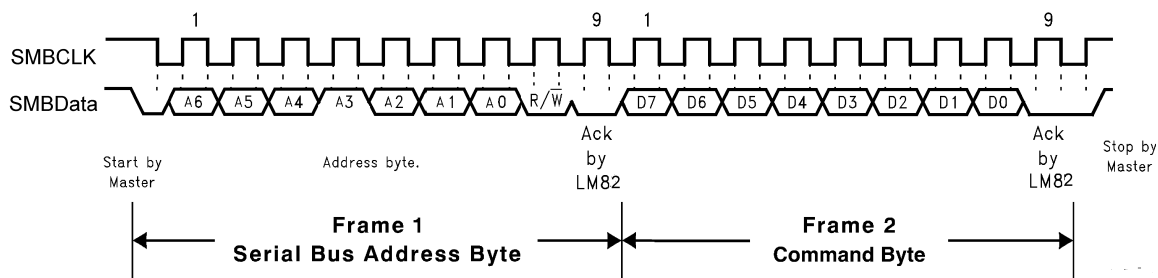

Figure 12. (b) Serial Bus Write to the internal Command Register

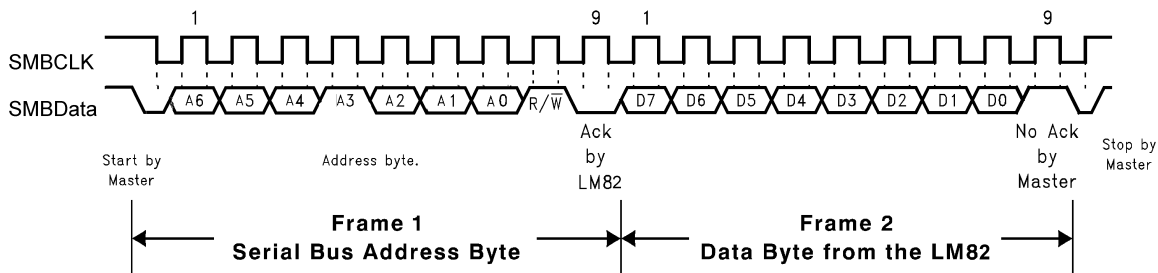

Figure 13. (c) Serial Bus Read from a Register with the internal Command Register preset to desired value

Application Hints

The LM82 can be applied easily in the same way as other integrated-circuit temperature sensors and its remote diode sensing capability allows it to be used in new ways as well. It can be soldered to a printed circuit board, and because the path of best thermal conductivity is between the die and the pins, its temperature will effectively be that of the printed circuit board lands and traces soldered to the LM82's pins. This presumes that the ambient air temperature is almost the same as the surface temperature of the printed circuit board; if the air temperature is much higher or lower than the surface temperature, the actual temperature of the LM82 die will be at an intermediate temperature between the surface and air temperatures. Again, the primary thermal conduction path is through the leads, so the circuit board temperature will contribute to the die temperature much more strongly than will the air temperature.

To measure temperature external to the LM82's die, use a remote diode. This diode can be located on the die of a target IC, allowing measurement of the IC's temperature, independent of the LM82's temperature. The LM82 has been optimized to measure the remote diode of a Pentium II processor as shown in Figure 14. A discrete diode can also be used to sense the temperature of external objects or ambient air. Remember that a discrete diode's temperature will be affected, and often dominated, by the temperature of its leads.

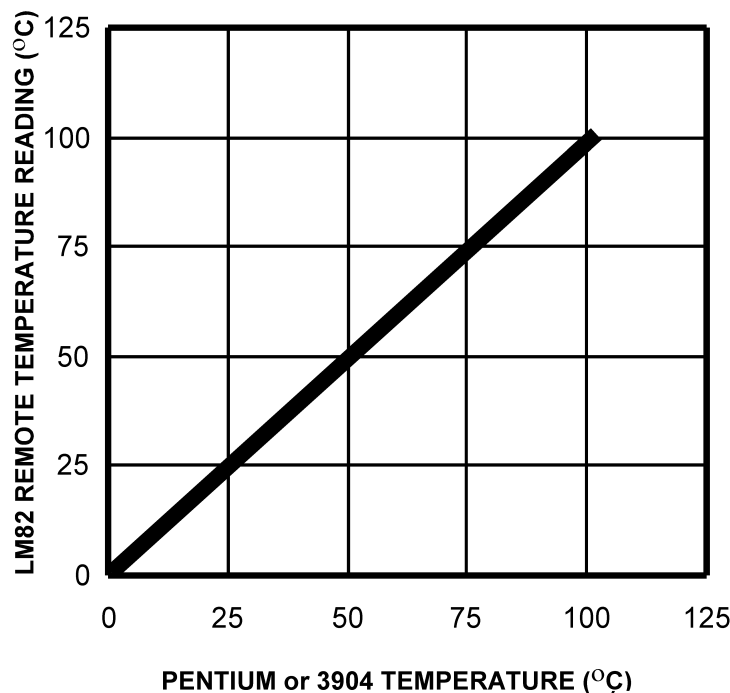

Figure 14. Pentium or 3904 Temperature vs LM82 Temperature Reading

Most silicon diodes do not lend themselves well to this application. It is recommended that a 2N3904 transistor base emitter junction be used with the collector tied to the base.

A diode connected 2N3904 approximates the junction available on a Pentium microprocessor for temperature measurement. Therefore, the LM82 can sense the temperature of this diode effectively.

ACCURACY EFFECTS OF DIODE NON-IDEALITY FACTOR

The technique used in today's remote temperature sensors is to measure the change in V_{BE} at two different operating points of a diode. For a bias current ratio of $N:1$, this difference is given as:

$$\Delta V_{BE} = \eta \frac{kT}{q} \ln(N)$$

where

- η is the non-ideality factor of the process the diode is manufactured on,

- q is the electron charge,
 - k is the Boltzmann's constant,
 - N is the current ratio,
 - T is the absolute temperature in °K.
- (1)

The temperature sensor then measures ΔV_{BE} and converts to digital data. In this equation, k and q are well defined universal constants, and N is a parameter controlled by the temperature sensor. The only other parameter is η , which depends on the diode that is used for measurement. Since ΔV_{BE} is proportional to both η and T , the variations in η cannot be distinguished from variations in temperature. Since the non-ideality factor is not controlled by the temperature sensor, it will directly add to the inaccuracy of the sensor. For the Pentium II Intel specifies a $\pm 1\%$ variation in η from part to part. As an example, assume a temperature sensor has an accuracy specification of ± 3 °C at room temperature of 25 °C and the process used to manufacture the diode has a non-ideality variation of $\pm 1\%$. The resulting accuracy of the temperature sensor at room temperature will be:

$$T_{ACC} = \pm 3^{\circ}\text{C} + (\pm 1\% \text{ of } 298 \text{ }^{\circ}\text{K}) = \pm 6 \text{ }^{\circ}\text{C} \quad (2)$$

The additional inaccuracy in the temperature measurement caused by η , can be eliminated if each temperature sensor is calibrated with the remote diode that it will be paired with.

PCB LAYOUT FOR MINIMIZING NOISE

In a noisy environment, such as a processor mother board, layout considerations are very critical. Noise induced on traces running between the remote temperature diode sensor and the LM82 can cause temperature conversion errors. The following guidelines should be followed:

1. Place a 0.1 μF power supply bypass capacitor as close as possible to the V_{CC} pin and the recommended 2.2 nF capacitor as close as possible to the D+ and D– pins. Make sure the traces to the 2.2nF capacitor are matched.
2. The recommended 2.2nF diode bypass capacitor actually has a range of 200pF to 3.3nF. The average temperature accuracy will not degrade. Increasing the capacitance will lower the corner frequency where differential noise error affects the temperature reading thus producing a reading that is more stable. Conversely, lowering the capacitance will increase the corner frequency where differential noise error affects the temperature reading thus producing a reading that is less stable.
3. Ideally, the LM82 should be placed within 10cm of the Processor diode pins with the traces being as straight, short and identical as possible. Trace resistance of 1 Ω can cause as much as 1°C of error.
4. Diode traces should be surrounded by a GND guard ring to either side, above and below if possible. This GND guard should not be between the D+ and D– lines. In the event that noise does couple to the diode lines it would be ideal if it is coupled common mode. That is equally to the D+ and D– lines. (See [Figure 15](#))
5. Avoid routing diode traces in close proximity to power supply switching signals or filtering inductors.
6. Avoid running diode traces close to or parallel to high speed digital and bus lines. Diode traces should be kept at least 2cm. apart from the high speed digital traces.
7. If it is necessary to cross high speed digital traces, the diode traces and the high speed digital traces should cross at a 90 degree angle.
8. The ideal place to connect the LM82's GND pin is as close as possible to the Processors GND associated with the sense diode.
9. Leakage current between D+ and GND should be kept to a minimum. One nano-ampere of leakage can cause as much as 1°C of error in the diode temperature reading. Keeping the printed circuit board as clean as possible will minimize leakage current.

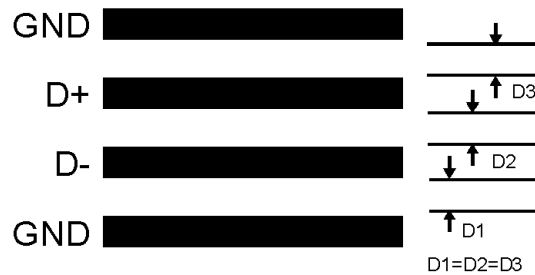

Figure 15. Ideal Diode Trace Layout

Noise coupling into the digital lines greater than 300mVp-p (typical hysteresis), overshoot greater than 500mV above V_{CC} , and undershoot less than 500mV below GND, may prevent successful SMBus communication with the LM82. SMBus no acknowledge is the most common symptom, causing unnecessary traffic on the bus. Although, the SMBus maximum frequency of communication is rather low (100kHz max) care still needs to be taken to ensure proper termination within a system with multiple parts on the bus and long printed circuit board traces. An R/C lowpass filter with a 3db corner frequency of about 40MHz has been included on the LM82's SMBCLK input. Additional resistance can be added in series with the SMBData and SMBCLK lines to further help filter noise and ringing. Minimize noise coupling by keeping digital traces out of switching power supply areas as well as ensuring that digital lines containing high speed data communications cross at right angles to the SMBData and SMBCLK lines.

REVISION HISTORY

Changes from Revision C (March 2013) to Revision D	Page
<hr/> <ul style="list-style-type: none">• Changed layout of National Data Sheet to TI format	<hr/> 20

PACKAGING INFORMATION

Orderable Device	Status (1)	Package Type	Package Drawing	Pins	Package Qty	Eco Plan (2)	Lead/Ball Finish (6)	MSL Peak Temp (3)	Op Temp (°C)	Device Marking (4/5)	Samples
LM82CIMQA/NOPB	ACTIVE	SSOP	DBQ	16	95	Green (RoHS & no Sb/Br)	CU SN	Level-1-260C-UNLIM	-40 to 125	82CI MQA	Samples
LM82CIMQAX/NOPB	ACTIVE	SSOP	DBQ	16	2500	Green (RoHS & no Sb/Br)	CU SN	Level-1-260C-UNLIM	-40 to 125	82CI MQA	Samples

(1) The marketing status values are defined as follows:

ACTIVE: Product device recommended for new designs.

LIFEBUY: TI has announced that the device will be discontinued, and a lifetime-buy period is in effect.

NRND: Not recommended for new designs. Device is in production to support existing customers, but TI does not recommend using this part in a new design.

PREVIEW: Device has been announced but is not in production. Samples may or may not be available.

OBSOLETE: TI has discontinued the production of the device.

(2) Eco Plan - The planned eco-friendly classification: Pb-Free (RoHS), Pb-Free (RoHS Exempt), or Green (RoHS & no Sb/Br) - please check <http://www.ti.com/productcontent> for the latest availability information and additional product content details.

TBD: The Pb-Free/Green conversion plan has not been defined.

Pb-Free (RoHS): TI's terms "Lead-Free" or "Pb-Free" mean semiconductor products that are compatible with the current RoHS requirements for all 6 substances, including the requirement that lead not exceed 0.1% by weight in homogeneous materials. Where designed to be soldered at high temperatures, TI Pb-Free products are suitable for use in specified lead-free processes.

Pb-Free (RoHS Exempt): This component has a RoHS exemption for either 1) lead-based flip-chip solder bumps used between the die and package, or 2) lead-based die adhesive used between the die and leadframe. The component is otherwise considered Pb-Free (RoHS compatible) as defined above.

Green (RoHS & no Sb/Br): TI defines "Green" to mean Pb-Free (RoHS compatible), and free of Bromine (Br) and Antimony (Sb) based flame retardants (Br or Sb do not exceed 0.1% by weight in homogeneous material)

(3) MSL, Peak Temp. - The Moisture Sensitivity Level rating according to the JEDEC industry standard classifications, and peak solder temperature.

(4) There may be additional marking, which relates to the logo, the lot trace code information, or the environmental category on the device.

(5) Multiple Device Markings will be inside parentheses. Only one Device Marking contained in parentheses and separated by a "~" will appear on a device. If a line is indented then it is a continuation of the previous line and the two combined represent the entire Device Marking for that device.

(6) Lead/Ball Finish - Orderable Devices may have multiple material finish options. Finish options are separated by a vertical ruled line. Lead/Ball Finish values may wrap to two lines if the finish value exceeds the maximum column width.

Important Information and Disclaimer: The information provided on this page represents TI's knowledge and belief as of the date that it is provided. TI bases its knowledge and belief on information provided by third parties, and makes no representation or warranty as to the accuracy of such information. Efforts are underway to better integrate information from third parties. TI has taken and continues to take reasonable steps to provide representative and accurate information but may not have conducted destructive testing or chemical analysis on incoming materials and chemicals. TI and TI suppliers consider certain information to be proprietary, and thus CAS numbers and other limited information may not be available for release.

In no event shall TI's liability arising out of such information exceed the total purchase price of the TI part(s) at issue in this document sold by TI to Customer on an annual basis.

GENERIC PACKAGE VIEW

DBQ 16

SSOP - 1.75 mm max height

SHRINK SMALL-OUTLINE PACKAGE

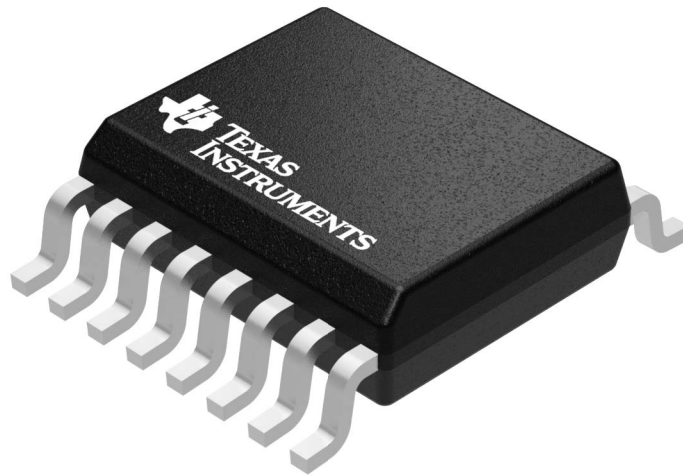

Images above are just a representation of the package family, actual package may vary.
Refer to the product data sheet for package details.

4073301-2/1

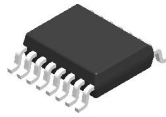

DBQ0016A

PACKAGE OUTLINE

SSOP - 1.75 mm max height

SHRINK SMALL-OUTLINE PACKAGE

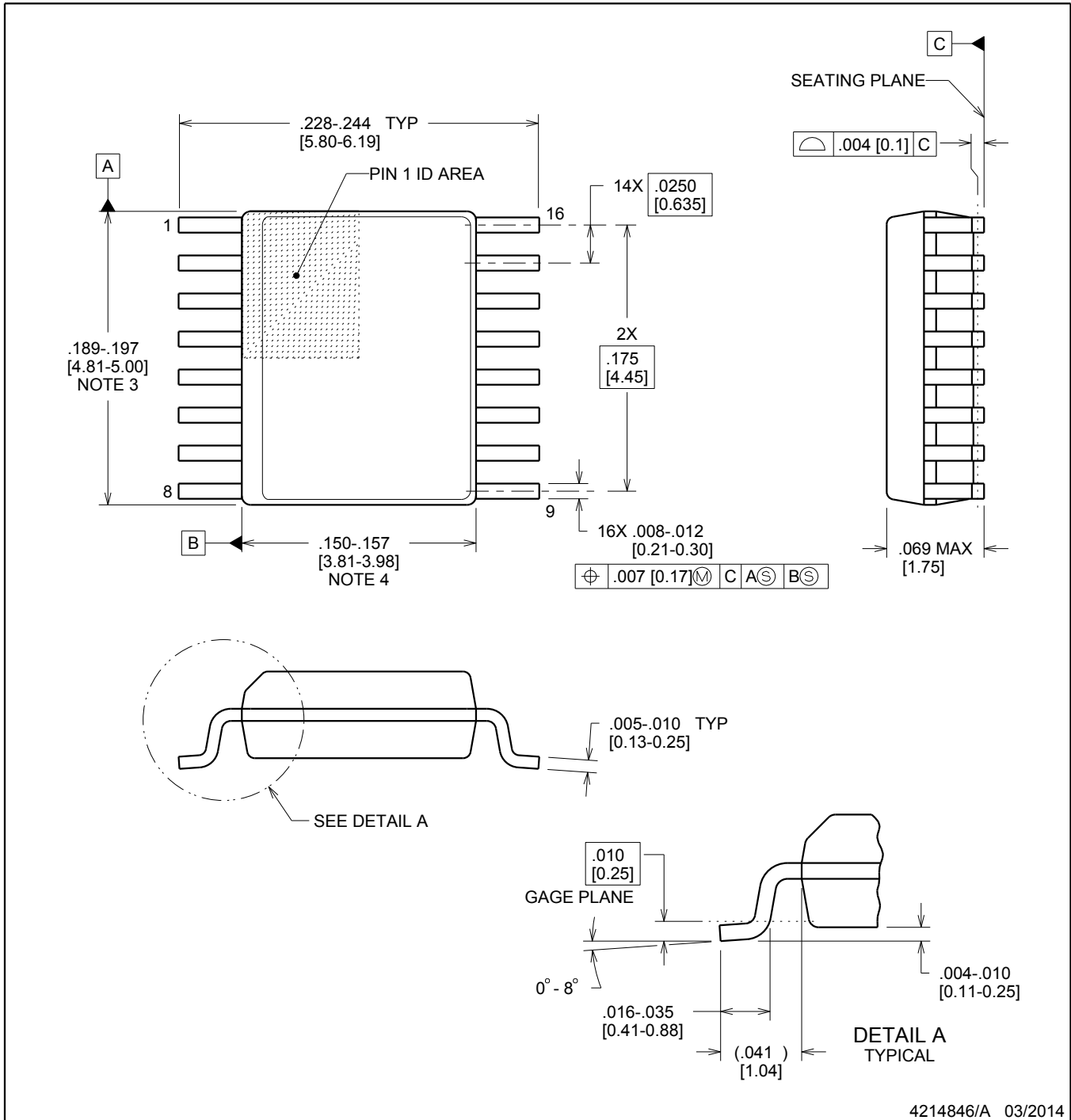

4214846/A 03/2014

NOTES:

1. Linear dimensions are in inches [millimeters]. Dimensions in parenthesis are for reference only. Controlling dimensions are in inches. Dimensioning and tolerancing per ASME Y14.5M.
2. This drawing is subject to change without notice.
3. This dimension does not include mold flash, protrusions, or gate burrs. Mold flash, protrusions, or gate burrs shall not exceed .006 inch, per side.
4. This dimension does not include interlead flash.
5. Reference JEDEC registration MO-137, variation AB.

EXAMPLE STENCIL DESIGN

DBQ0016A

SSOP - 1.75 mm max height

SHRINK SMALL-OUTLINE PACKAGE

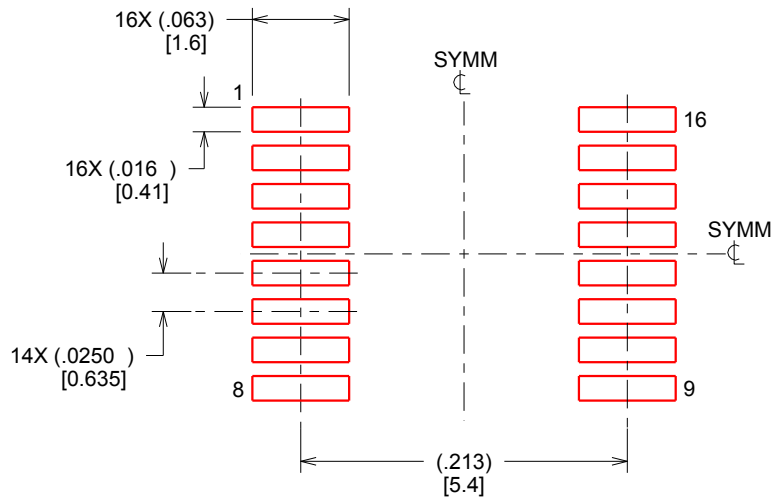

SOLDER PASTE EXAMPLE
BASED ON .005 INCH [0.127 MM] THICK STENCIL
SCALE:8X

4214846/A 03/2014

NOTES: (continued)

8. Laser cutting apertures with trapezoidal walls and rounded corners may offer better paste release. IPC-7525 may have alternate design recommendations.
9. Board assembly site may have different recommendations for stencil design.

IMPORTANT NOTICE

Texas Instruments Incorporated (TI) reserves the right to make corrections, enhancements, improvements and other changes to its semiconductor products and services per JESD46, latest issue, and to discontinue any product or service per JESD48, latest issue. Buyers should obtain the latest relevant information before placing orders and should verify that such information is current and complete.

TI's published terms of sale for semiconductor products (<http://www.ti.com/sc/docs/stdterms.htm>) apply to the sale of packaged integrated circuit products that TI has qualified and released to market. Additional terms may apply to the use or sale of other types of TI products and services.

Reproduction of significant portions of TI information in TI data sheets is permissible only if reproduction is without alteration and is accompanied by all associated warranties, conditions, limitations, and notices. TI is not responsible or liable for such reproduced documentation. Information of third parties may be subject to additional restrictions. Resale of TI products or services with statements different from or beyond the parameters stated by TI for that product or service voids all express and any implied warranties for the associated TI product or service and is an unfair and deceptive business practice. TI is not responsible or liable for any such statements.

Buyers and others who are developing systems that incorporate TI products (collectively, "Designers") understand and agree that Designers remain responsible for using their independent analysis, evaluation and judgment in designing their applications and that Designers have full and exclusive responsibility to assure the safety of Designers' applications and compliance of their applications (and of all TI products used in or for Designers' applications) with all applicable regulations, laws and other applicable requirements. Designer represents that, with respect to their applications, Designer has all the necessary expertise to create and implement safeguards that (1) anticipate dangerous consequences of failures, (2) monitor failures and their consequences, and (3) lessen the likelihood of failures that might cause harm and take appropriate actions. Designer agrees that prior to using or distributing any applications that include TI products, Designer will thoroughly test such applications and the functionality of such TI products as used in such applications.

TI's provision of technical, application or other design advice, quality characterization, reliability data or other services or information, including, but not limited to, reference designs and materials relating to evaluation modules, (collectively, "TI Resources") are intended to assist designers who are developing applications that incorporate TI products; by downloading, accessing or using TI Resources in any way, Designer (individually or, if Designer is acting on behalf of a company, Designer's company) agrees to use any particular TI Resource solely for this purpose and subject to the terms of this Notice.

TI's provision of TI Resources does not expand or otherwise alter TI's applicable published warranties or warranty disclaimers for TI products, and no additional obligations or liabilities arise from TI providing such TI Resources. TI reserves the right to make corrections, enhancements, improvements and other changes to its TI Resources. TI has not conducted any testing other than that specifically described in the published documentation for a particular TI Resource.

Designer is authorized to use, copy and modify any individual TI Resource only in connection with the development of applications that include the TI product(s) identified in such TI Resource. NO OTHER LICENSE, EXPRESS OR IMPLIED, BY ESTOPPEL OR OTHERWISE TO ANY OTHER TI INTELLECTUAL PROPERTY RIGHT, AND NO LICENSE TO ANY TECHNOLOGY OR INTELLECTUAL PROPERTY RIGHT OF TI OR ANY THIRD PARTY IS GRANTED HEREIN, including but not limited to any patent right, copyright, mask work right, or other intellectual property right relating to any combination, machine, or process in which TI products or services are used. Information regarding or referencing third-party products or services does not constitute a license to use such products or services, or a warranty or endorsement thereof. Use of TI Resources may require a license from a third party under the patents or other intellectual property of the third party, or a license from TI under the patents or other intellectual property of TI.

TI RESOURCES ARE PROVIDED "AS IS" AND WITH ALL FAULTS. TI DISCLAIMS ALL OTHER WARRANTIES OR REPRESENTATIONS, EXPRESS OR IMPLIED, REGARDING RESOURCES OR USE THEREOF, INCLUDING BUT NOT LIMITED TO ACCURACY OR COMPLETENESS, TITLE, ANY EPIDEMIC FAILURE WARRANTY AND ANY IMPLIED WARRANTIES OF MERCHANTABILITY, FITNESS FOR A PARTICULAR PURPOSE, AND NON-INFRINGEMENT OF ANY THIRD PARTY INTELLECTUAL PROPERTY RIGHTS. TI SHALL NOT BE LIABLE FOR AND SHALL NOT DEFEND OR INDEMNIFY DESIGNER AGAINST ANY CLAIM, INCLUDING BUT NOT LIMITED TO ANY INFRINGEMENT CLAIM THAT RELATES TO OR IS BASED ON ANY COMBINATION OF PRODUCTS EVEN IF DESCRIBED IN TI RESOURCES OR OTHERWISE. IN NO EVENT SHALL TI BE LIABLE FOR ANY ACTUAL, DIRECT, SPECIAL, COLLATERAL, INDIRECT, PUNITIVE, INCIDENTAL, CONSEQUENTIAL OR EXEMPLARY DAMAGES IN CONNECTION WITH OR ARISING OUT OF TI RESOURCES OR USE THEREOF, AND REGARDLESS OF WHETHER TI HAS BEEN ADVISED OF THE POSSIBILITY OF SUCH DAMAGES.

Unless TI has explicitly designated an individual product as meeting the requirements of a particular industry standard (e.g., ISO/TS 16949 and ISO 26262), TI is not responsible for any failure to meet such industry standard requirements.

Where TI specifically promotes products as facilitating functional safety or as compliant with industry functional safety standards, such products are intended to help enable customers to design and create their own applications that meet applicable functional safety standards and requirements. Using products in an application does not by itself establish any safety features in the application. Designers must ensure compliance with safety-related requirements and standards applicable to their applications. Designer may not use any TI products in life-critical medical equipment unless authorized officers of the parties have executed a special contract specifically governing such use. Life-critical medical equipment is medical equipment where failure of such equipment would cause serious bodily injury or death (e.g., life support, pacemakers, defibrillators, heart pumps, neurostimulators, and implantables). Such equipment includes, without limitation, all medical devices identified by the U.S. Food and Drug Administration as Class III devices and equivalent classifications outside the U.S.

TI may expressly designate certain products as completing a particular qualification (e.g., Q100, Military Grade, or Enhanced Product). Designers agree that it has the necessary expertise to select the product with the appropriate qualification designation for their applications and that proper product selection is at Designers' own risk. Designers are solely responsible for compliance with all legal and regulatory requirements in connection with such selection.

Designer will fully indemnify TI and its representatives against any damages, costs, losses, and/or liabilities arising out of Designer's non-compliance with the terms and provisions of this Notice.

Looking for pricing, stock, or lifecycle information?

Click below to explore more details on WIN SOURCE:

 [View LM82CIMQA/NOPB on WIN SOURCE](#)

 [Texas Instruments](#) Information

Optimize Your Supply Chain with WIN SOURCE Solutions

-  Global Sourcing Solution
-  Obsolete Management
-  Cost Control Management
-  Shortage Management
-  Alternative Solution
-  Excess Inventory Management