



**THE DATASHEET OF  
843252AGLFT**



## General Description

The 843252 is a 2 differential output LVPECL Synthesizer designed to generate Ethernet reference clock frequencies. Using a 25MHz, 18pF parallel resonant crystal, the following frequencies can be generated based on the settings of 4 frequency select pins (SELA[1:0], SELB[1:0]): 625MHz, 312.5MHz, 156.25MHz, and 125MHz.

The two banks have their own dedicated frequency select pins and can be independently set for the frequencies mentioned above. The 843252 IDT's 3<sup>rd</sup> generation low phase noise VCO technology and can achieve 1ps or lower typical rms phase jitter, easily meeting Ethernet jitter requirements. The 843252 is packaged in a small 16-pin TSSOP package.

## Features

- Two differential LVPECL output pairs
- Using a 25MHz crystal, the two output banks can be independently set for 625MHz, 312.5MHz, 156.25MHz or 125MHz
- Crystal oscillator interface
- VCO frequency: 490MHz – 680MHz
- RMS Phase Jitter @ 156.25MHz, (1.875MHz – 20MHz) using a 25MHz crystal: 0.47ps (typical)
- Full 3.3V supply mode
- 0°C to 70°C ambient operating temperature
- Industrial temperature available upon request
- Available in lead-free (RoHS 6) package

## Block Diagram

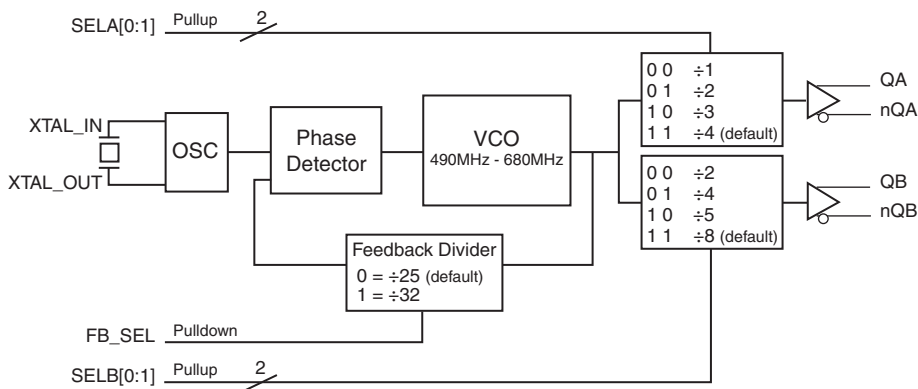

## Pin Assignment

nQB	1	16	XTAL_IN
QB	2	15	XTAL_OUT
Vcco_B	3	14	VEE
SELB1	4	13	SELA1
SELB0	5	12	SELA0
Vcco_A	6	11	Vcc
QA	7	10	VCCA
nQA	8	9	FB_SEL

**843252**  
**16-Lead TSSOP**  
**4.4mm x 5.0mm x 0.925mm package body**  
**G Package**

## Pin Description and Pin Characteristics

**Table 1. Pin Descriptions**

Number	Name	Type		Description
1, 2	nQB, QB	Output		Bank B differential output pair. LVPECL interface levels.
3	V <sub>CCO_B</sub>	Power		Output supply pin for QB, nQB outputs.
4, 5	SELB1, SELB0	Input	Pullup	Division select pins for Bank B. LVCMOS/LVTTL interface levels.
6	V <sub>CCO_A</sub>	Power		Output supply pin for QA, nQA outputs.
7, 8	QA, nQA	Output		Bank A differential output pair. LVPECL interface levels.
9	FB_SEL	Input	Pulldown	Feedback divide select. When LOW, the feedback divider is set for $\div 25$ . When HIGH, the feedback divider is set for $\div 32$ . LVCMOS/LVTTL interface levels.
10	V <sub>CCA</sub>	Power		Analog supply pin.
11	V <sub>CC</sub>	Power		Core supply pin.
12, 13	SELA0, SELA1	Input	Pullup	Division select pins for Bank A. LVCMOS/LVTTL interface levels.
14	V <sub>EE</sub>	Power		Negative supply pin.
15, 16	XTAL_OUT XTAL_IN	Input		Crystal oscillator interface XTAL_IN is the input, XTAL_OUT is the output.

NOTE: *Pullup* and *Pulldown* refer to internal input resistors. See Table 2, *Pin Characteristics*, for typical values.

**Table 2. Pin Characteristics**

Symbol	Parameter	Test Conditions	Minimum	Typical	Maximum	Units
C <sub>IN</sub>	Input Capacitance			4		pF
R <sub>PULLUP</sub>	Input Pullup Resistor			51		k $\Omega$
R <sub>PULLDOWN</sub>	Input Pulldown Resistor			51		k $\Omega$

## Function Tables

Table 3A. Bank A Frequency Table

Inputs				Feedback Divider	Bank A Output Divider	M/N Multiplication Factor	QA, nQA Output Frequency (MHz)
Crystal Frequency (MHz)	FB_SEL	SELA1	SELA0				
25	0	0	0	25	1	25	625
25	0	0	1	25	2	12.5	312.5
20	0	0	1	25	2	12.5	250
22.5	0	1	0	25	3	8.333	187.5
25	0	1	1	25	4	6.25	156.25
24	0	1	1	25	4	6.25	150
20	0	1	1	25	4	6.25	125
19.44	1	0	0	32	1	32	622.08
19.44	1	0	1	32	2	16	311.04
15.625	1	0	1	32	2	16	250
18.75	1	1	0	32	3	10.667	200
19.44	1	1	1	32	4	8	155.52
18.75	1	1	1	32	4	8	150
15.625	1	1	1	32	4	8	125

**Table 3B. Bank B Frequency Table**

Inputs				Feedback Divider	Bank B Output Divider	M/N Multiplication Factor	QB, nQB Output Frequency (MHz)
Crystal Frequency (MHz)	FB_SEL	SELB1	SELB0				
25	0	0	0	25	2	12.5	312.5
20	0	0	0	25	2	12.5	250
25	0	0	1	25	4	6.25	156.25
24	0	0	1	25	4	6.25	150
20	0	0	1	25	4	6.25	125
25	0	1	0	25	5	5	125
25	0	1	1	25	8	3.125	78.125
24	0	1	1	25	8	3.125	75
20	0	1	1	25	8	3.125	62.5
19.44	1	0	0	32	2	16	311.04
15.625	1	0	0	32	2	16	250
19.44	1	0	1	32	4	8	155.52
18.75	1	0	1	32	4	8	150
15.625	1	0	1	32	4	8	125
15.625	1	1	0	32	5	6.4	100
19.44	1	1	1	32	8	4	77.76
18.75	1	1	1	32	8	4	75
15.625	1	1	1	32	8	4	62.5

**Table 3C. Output Bank A Configuration Select Function Table**

Inputs		Outputs
SELA1	SELA0	QA, nQA
0	0	÷1
0	1	÷2
1	0	÷3
1	1	÷4 (default)

**Table 3D. Output Bank B Configuration Select Function Table**

Inputs		Outputs
SELB1	SELB0	QB, nQB
0	0	÷2
0	1	÷4
1	0	÷5
1	1	÷8 (default)

**Table 3E. Feedback Divider Configuration Select Function Table**

Input	
FB_SEL	Feedback Divide
0	÷25 (default)
1	÷32

## Absolute Maximum Ratings

NOTE: Stresses beyond those listed under *Absolute Maximum Ratings* may cause permanent damage to the device. These ratings are stress specifications only. Functional operation of product at these conditions or any conditions beyond those listed in the *DC Characteristics* or *AC Characteristics* is not implied. Exposure to absolute maximum rating conditions for extended periods may affect product reliability.

Item	Rating
Supply Voltage, $V_{CC}$	4.6V
Inputs, $V_I$	-0.5V to $V_{CC} + 0.5V$
Outputs, $I_O$ Continuous Current Surge Current	50mA 100mA
Package Thermal Impedance, $\theta_{JA}$	92.4°C/W (0 mps)
Storage Temperature, $T_{STG}$	-65°C to 150°C

## DC Electrical Characteristics

**Table 4A. Power Supply DC Characteristics,  $V_{CC} = V_{CCO\_A} = V_{CCO\_B} = 3.3V \pm 5\%$ ,  $V_{EE} = 0V$ ,  $T_A = 0^\circ C$  to  $70^\circ C$**

Symbol	Parameter	Test Conditions	Minimum	Typical	Maximum	Units
$V_{CC}$	Core Supply Voltage		3.135	3.3	3.465	V
$V_{CCA}$	Analog Supply Voltage		$V_{CC} - 0.10$	3.3	$V_{CC}$	V
$V_{CCO\_A}$ , $V_{CCO\_B}$	Power Supply Voltage		3.135	3.3	3.465	V
$I_{CCA}$	Analog Supply Current				10	mA
$I_{EE}$	Power Supply Current				145	mA

**Table 4B. LVCMOS/LVTTL DC Characteristics,  $V_{CC} = V_{CCO\_A} = V_{CCO\_B} = 3.3V \pm 5\%$ ,  $V_{EE} = 0V$ ,  $T_A = 0^\circ C$  to  $70^\circ C$**

Symbol	Parameter	Test Conditions	Minimum	Typical	Maximum	Units
$V_{IH}$	Input High Voltage		2		$V_{CC} + 0.3$	V
$V_{IL}$	Input Low Voltage		-0.3		0.8	V
$I_{IH}$	Input High Current	FB_SEL	$V_{CC} = V_{IN} = 3.465V$		150	$\mu A$
		SELA[1:0], SELB[1:0]	$V_{CC} = V_{IN} = 3.465V$		5	$\mu A$
$I_{IL}$	Input Low Current	FB_SEL	$V_{CC} = 3.465V, V_{IN} = 0V$	-5		$\mu A$
		SELA[1:0], SELB[1:0]	$V_{CC} = 3.465V, V_{IN} = 0V$	-150		$\mu A$

**Table 4C. LVPECL DC Characteristics,  $V_{CC} = V_{CCO\_A} = V_{CCO\_B} = 3.3V \pm 5\%$ ,  $V_{EE} = 0V$ ,  $T_A = 0^\circ C$  to  $70^\circ C$** 

Symbol	Parameter	Test Conditions	Minimum	Typical	Maximum	Units
$V_{OH}$	Output High Voltage; NOTE 1		$V_{CCO\_X} - 1.4$		$V_{CCO\_X} - 0.9$	V
$V_{OL}$	Output Low Voltage; NOTE 1		$V_{CCO\_X} - 2.0$		$V_{CCO\_X} - 1.7$	V
$V_{SWING}$	Peak-to-Peak Output Voltage Swing		0.6		1.0	V

 NOTE 1: Output termination with  $50\Omega$  to  $V_{CCO\_A, B} - 2V$ .

**Table 5. Crystal Characteristics**

Parameter	Test Conditions	Minimum	Typical	Maximum	Units
Mode of Oscillation		Fundamental			
Frequency	FB_SEL = $\div 25$	19.6		27.2	MHz
	FB_SEL = $\div 32$	15.313		21.25	MHz
Equivalent Series Resistance (ESR)				50	$\Omega$
Shunt Capacitance				7	pF
Drive Level				1	mW

NOTE: Characterized using an 18pF parallel resonant crystal.

## AC Electrical Characteristics

**Table 6. AC Characteristics,  $V_{CC} = V_{CCO\_A} = V_{CCO\_B} = 3.3V \pm 5\%$ ,  $V_{EE} = 0V$ ,  $T_A = 0^\circ C$  to  $70^\circ C$** 

Symbol	Parameter	Test Conditions	Minimum	Typical	Maximum	Units
$f_{OUT}$	Output Frequency Range	Output Divider = $\div 1$	490		680	MHz
		Output Divider = $\div 2$	245		340	MHz
		Output Divider = $\div 3$	163.33		226.67	MHz
		Output Divider = $\div 4$	122.5		170	MHz
		Output Divider = $\div 5$	98		136	MHz
		Output Divider = $\div 8$	61.25		85	MHz
$t_{sk(o)}$	Output Skew; NOTE 1, 2	Outputs @ Same Frequency			80	ps
		Outputs @ Different Frequencies			190	ps
$f_{jit}(\emptyset)$	RMS Phase Jitter, (Random); NOTE 3	625MHz, (1.875MHz – 20MHz)		0.36		ps
		312.5MHz, (1.875MHz – 20MHz)		0.43		ps
		156.25MHz, (1.875MHz – 20MHz)		0.47		ps
		125MHz, (1.875MHz – 20MHz)		0.47		ps
$t_R / t_F$	Output Rise/Fall Time	20% to 80%	300		700	ps
odc	Output Duty Cycle		47		53	%

NOTE: Electrical parameters are guaranteed over the specified ambient operating temperature range, which is established when the device is mounted in a test socket with maintained transverse airflow greater than 500 lfm. The device will meet specifications after thermal equilibrium has been reached under these conditions.

NOTE 1: Defined as skew between outputs at the same supply voltages and with equal load conditions. Measured at the output differential cross points.

NOTE 2: This parameter is defined in accordance with JEDEC Standard 65.

NOTE 3: Please refer to the Phase Noise Plots.

### Typical Phase Noise at 625MHz

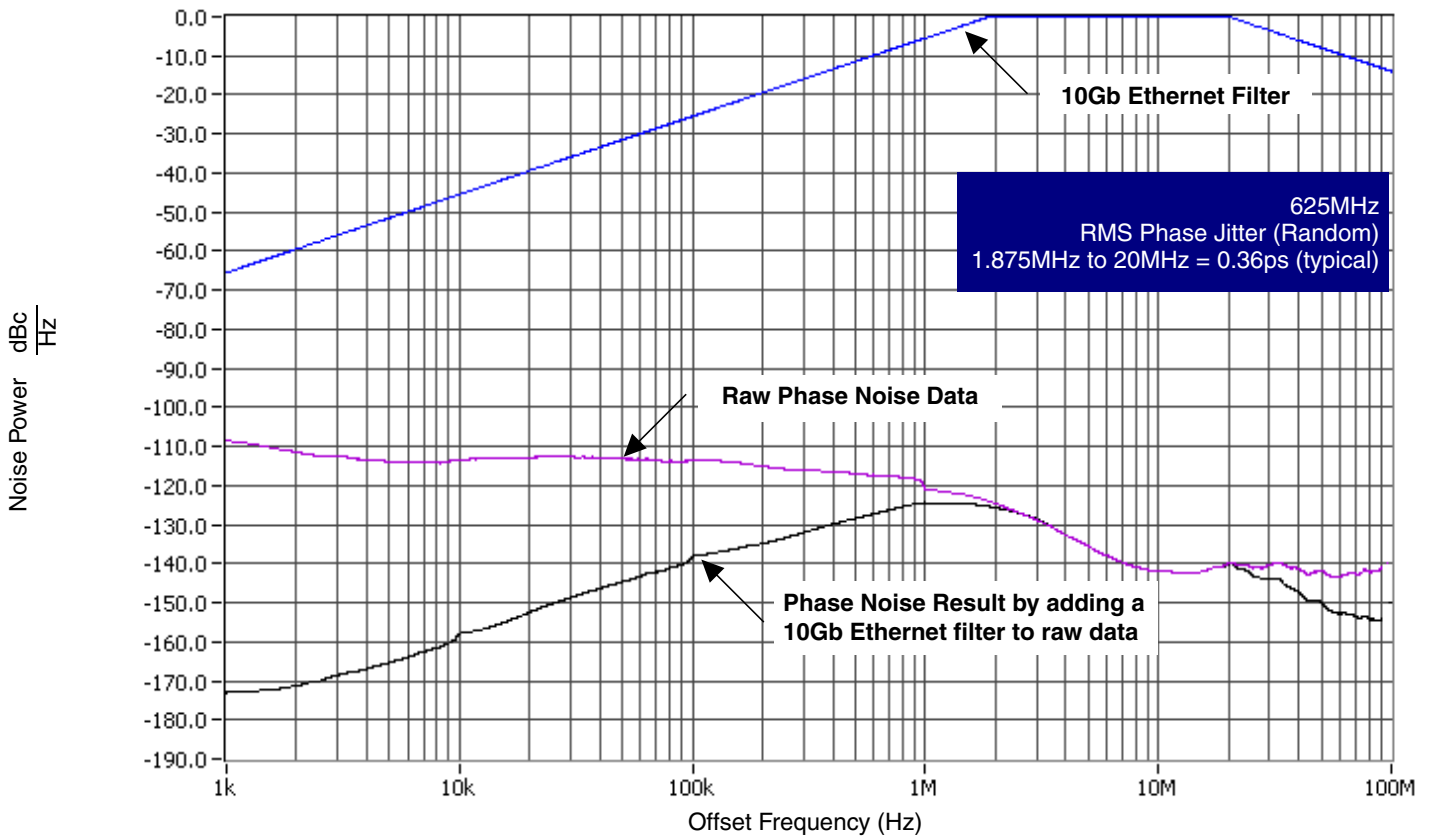

### Typical Phase Noise at 156.25MHz

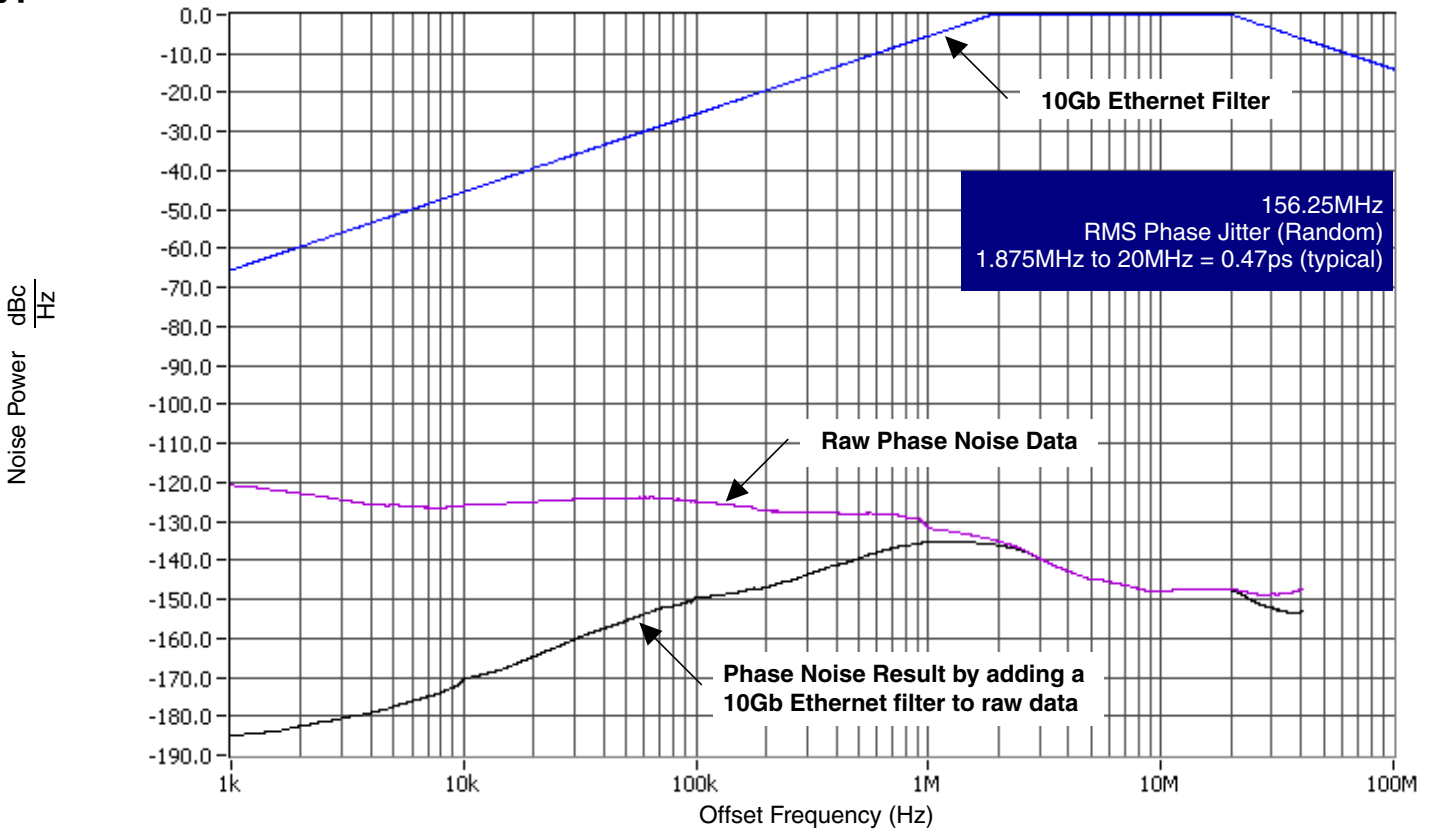

### Parameter Measurement Information

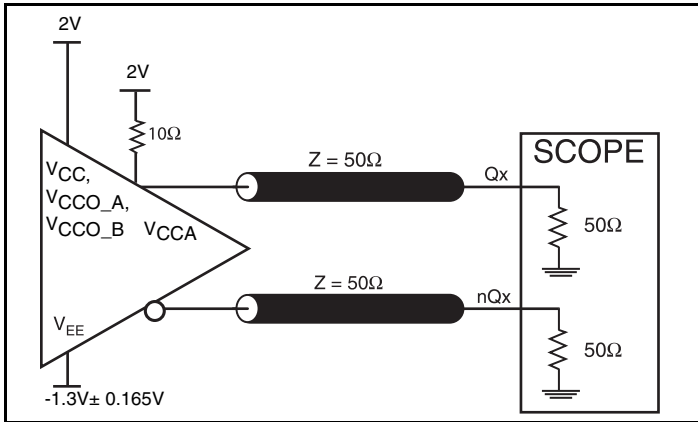

3.3V LVPECL Output Load AC Test Circuit

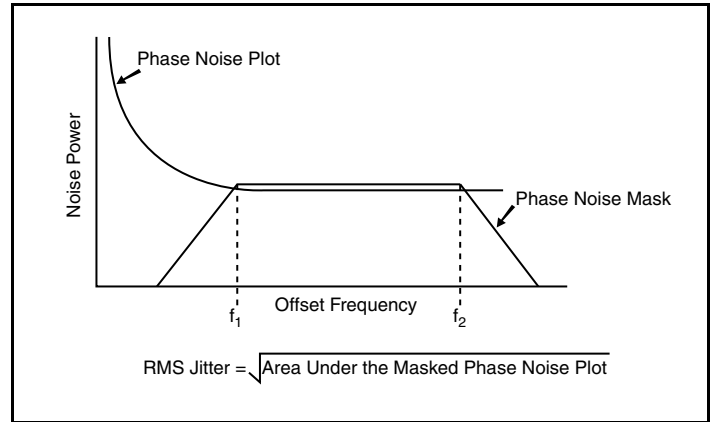

RMS Phase Jitter

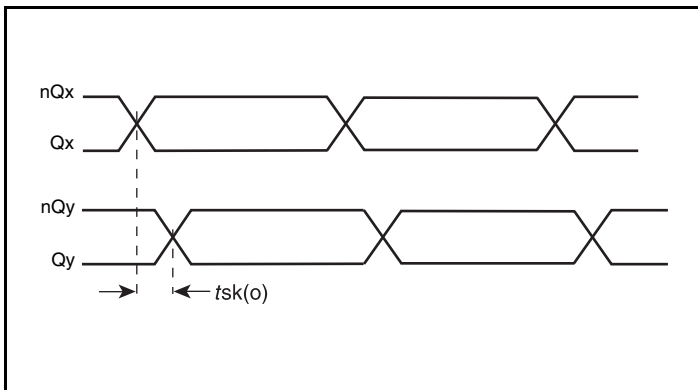

Output Skew

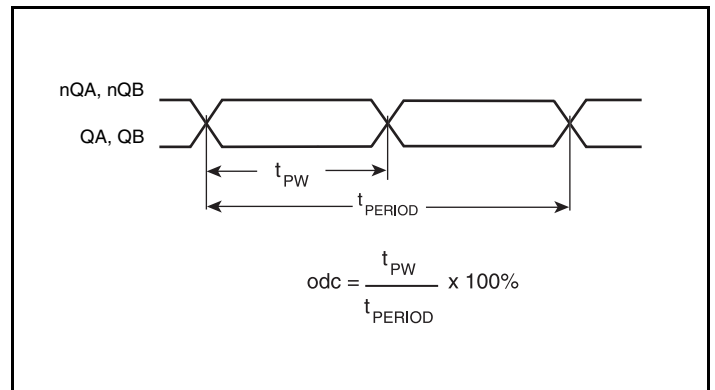

Output Duty Cycle/Pulse Width/Period

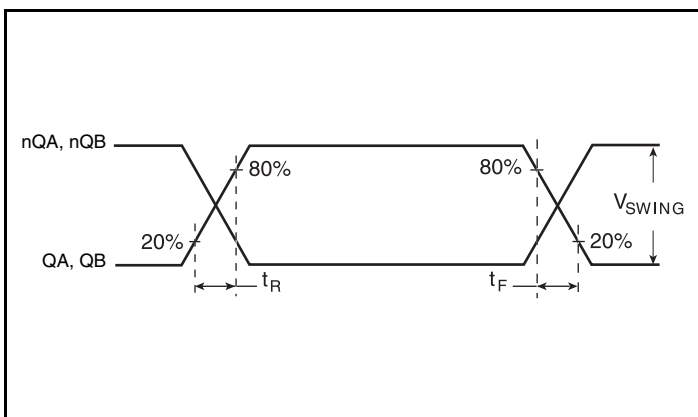

Output Rise/Fall Time

## Application Information

### Recommendations for Unused Input Pins

#### Inputs:

##### LVC MOS Control Pins

All control pins have internal pullups and pulldowns; additional resistance is not required but can be added for additional protection. A 1k $\Omega$  resistor can be used.

#### Outputs:

##### LVPECL Outputs

All unused LVPECL outputs can be left floating. We recommend that there is no trace attached. Both sides of the differential output pair should either be left floating or terminated.

### Power Supply Filtering Technique

As in any high speed analog circuitry, the power supply pins are vulnerable to random noise. To achieve optimum jitter performance, power supply isolation is required. The 843252 provides separate power supplies to isolate any high switching noise from the outputs to the internal PLL.  $V_{CC}$ ,  $V_{CCA}$ ,  $V_{CCO\_A}$ , and  $V_{CCO\_B}$  should be individually connected to the power supply plane through vias, and 0.01 $\mu$ F bypass capacitors should be used for each pin. *Figure 1* illustrates this for a generic  $V_{CC}$  pin and also shows that  $V_{CCA}$  requires that an additional 10 $\Omega$  resistor along with a 10 $\mu$ F bypass capacitor be connected to the  $V_{CCA}$  pin.

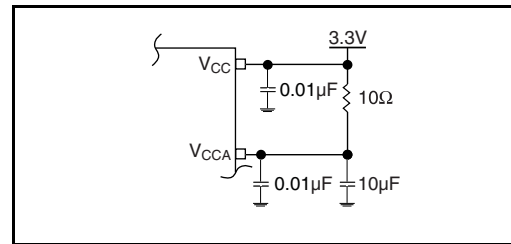

**Figure 1. Power Supply Filtering**

### Crystal Input Interface

The 843252 has been characterized with 18pF parallel resonant crystals. The capacitor values, C1 and C2, shown in *Figure 2* below were determined using a 25MHz, 18pF parallel resonant crystal and were chosen to minimize the ppm error.

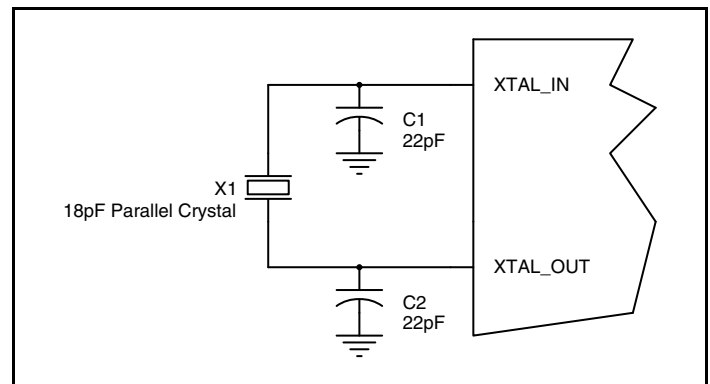

**Figure 2. Crystal Input Interface**

### LVC MOS to XTAL Interface

The XTAL\_IN input can accept a single-ended LVC MOS signal through an AC coupling capacitor. A general interface diagram is shown in Figure 3. The XTAL\_OUT pin can be left floating. The input edge rate can be as slow as 10ns. For LVC MOS inputs, it is recommended that the amplitude be reduced from full swing to half swing in order to prevent signal interference with the power rail and to reduce noise. This configuration requires that the output

impedance of the driver ( $R_o$ ) plus the series resistance ( $R_s$ ) equals the transmission line impedance. In addition, matched termination at the crystal input will attenuate the signal in half. This can be done in one of two ways. First,  $R_1$  and  $R_2$  in parallel should equal the transmission line impedance. For most  $50\Omega$  applications,  $R_1$  and  $R_2$  can be  $100\Omega$ . This can also be accomplished by removing  $R_1$  and making  $R_2$   $50\Omega$ .

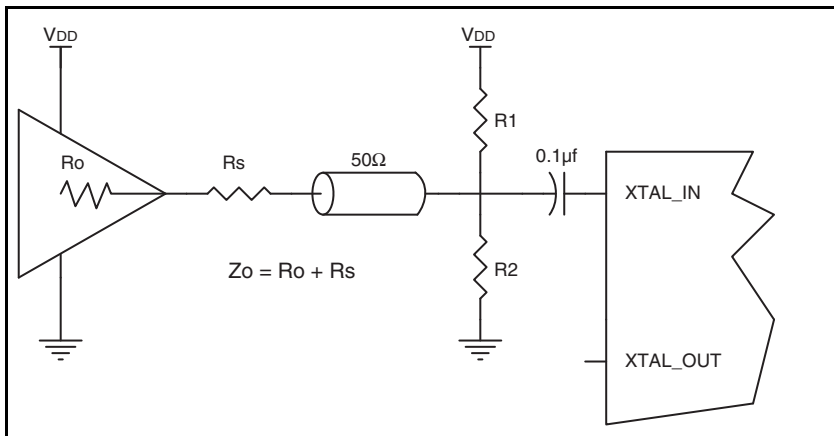

Figure 3. General Diagram for LVC MOS Driver to XTAL Input Interface

### Termination for 3.3V LVPECL Outputs

The clock layout topology shown below is a typical termination for LVPECL outputs. The two different layouts mentioned are recommended only as guidelines.

The differential outputs are low impedance follower outputs that generate ECL/LVPECL compatible outputs. Therefore, terminating resistors (DC current path to ground) or current sources must be used for functionality. These outputs are designed to drive  $50\Omega$

transmission lines. Matched impedance techniques should be used to maximize operating frequency and minimize signal distortion. Figures 4A and 4B show two different layouts which are recommended only as guidelines. Other suitable clock layouts may exist and it would be recommended that the board designers simulate to guarantee compatibility across all printed circuit and clock component process variations.

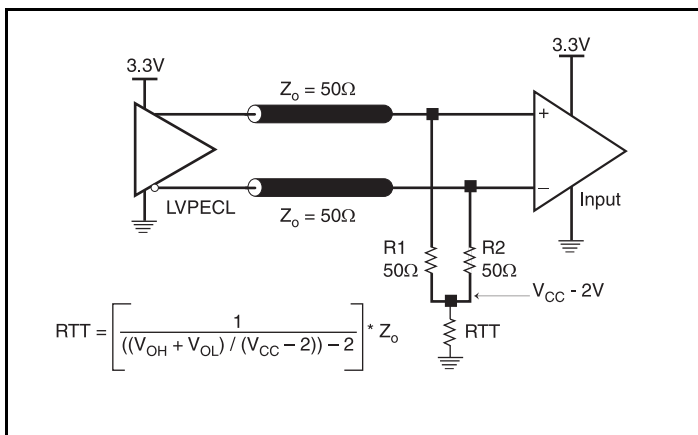

Figure 4A. 3.3V LVPECL Output Termination

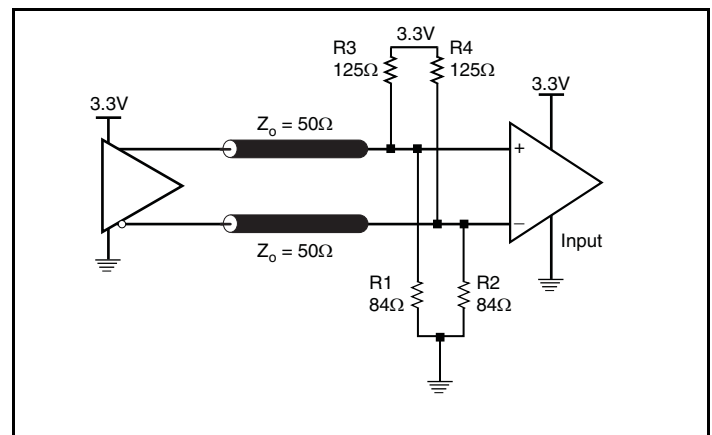

Figure 4B. 3.3V LVPECL Output Termination

### Schematic Example

Figure 5 shows an example of 843252 application schematic. In this example, the device is operated at  $V_{CC} = 3.3V$ . The 18pF parallel resonant 25MHz crystal is used. The  $C1 = 22pF$  and  $C2 = 22pF$  are recommended for frequency accuracy. For different board layouts, the  $C1$  and  $C2$  may be slightly adjusted for

optimizing frequency accuracy. Two examples of LVPECL terminations are shown in this schematic. Additional termination approaches are shown in the *LVPECL Termination Application Note*.

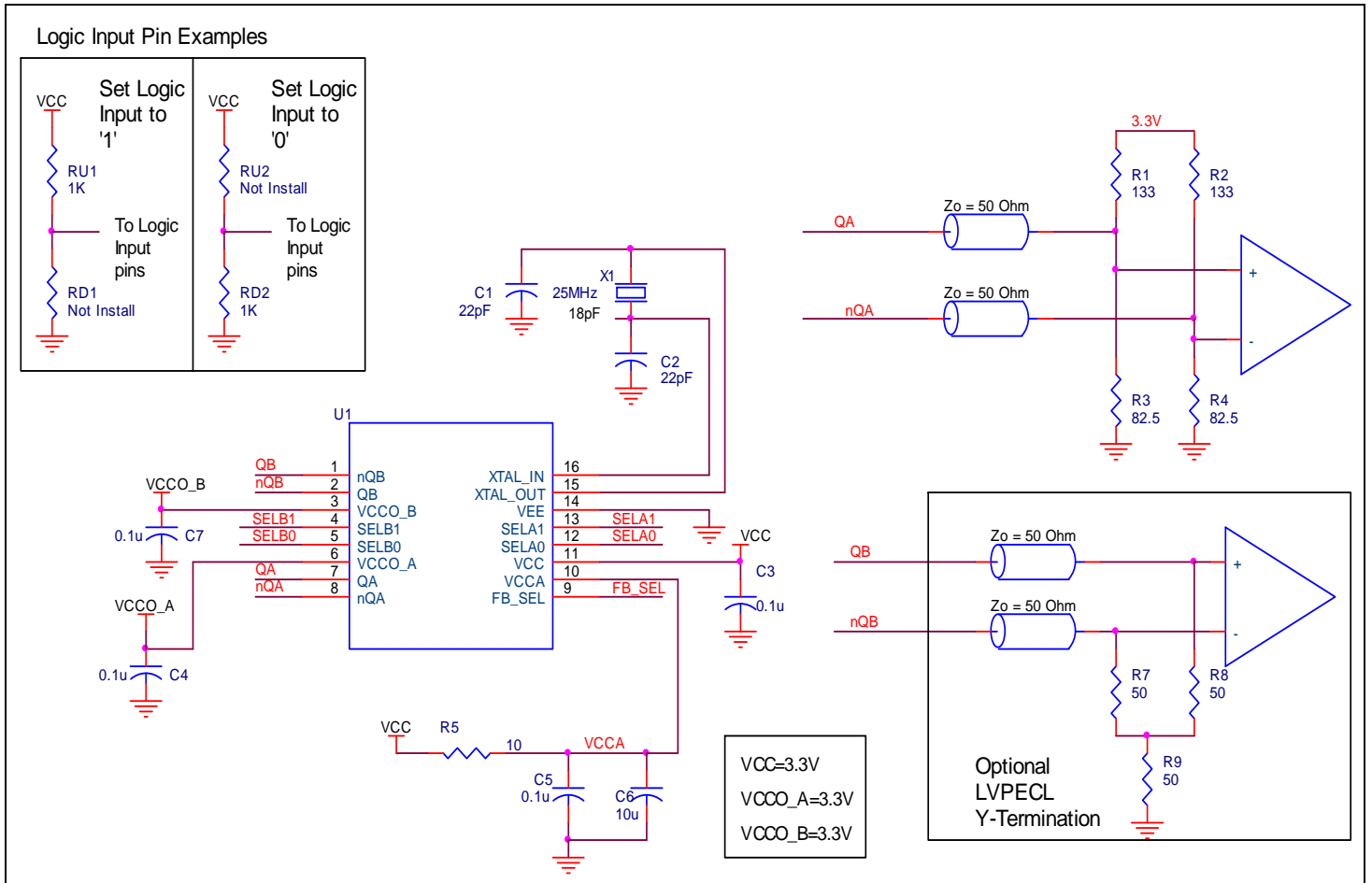

Figure 5. 843252 Schematic Example

## Power Considerations

This section provides information on power dissipation and junction temperature for the 843252. Equations and example calculations are also provided.

### 1. Power Dissipation.

The total power dissipation for the 843252 is the sum of the core power plus the power dissipated in the load(s). The following is the power dissipation for  $V_{CC} = 3.3V + 5\% = 3.465V$ , which gives worst case results.

NOTE: Please refer to Section 3 for details on calculating power dissipated in the load.

- Power (core)<sub>MAX</sub> =  $V_{CC\_MAX} * I_{EE\_MAX} = 3.465V * 145mA = 502.43mW$
- Power (outputs)<sub>MAX</sub> = **30mW/Loaded Output pair**  
If all outputs are loaded, the total power is  $2 * 30mW = 60mW$

**Total Power<sub>MAX</sub>** (3.3V, with all outputs switching) =  $502.43mW + 60mW = 562.43mW$

### 2. Junction Temperature.

Junction temperature,  $T_j$ , is the temperature at the junction of the bond wire and bond pad and directly affects the reliability of the device. The maximum recommended junction temperature for devices is 125°C.

The equation for  $T_j$  is as follows:  $T_j = \theta_{JA} * Pd\_total + T_A$

$T_j$  = Junction Temperature

$\theta_{JA}$  = Junction-to-Ambient Thermal Resistance

$Pd\_total$  = Total Device Power Dissipation (example calculation is in section 1 above)

$T_A$  = Ambient Temperature

In order to calculate junction temperature, the appropriate junction-to-ambient thermal resistance  $\theta_{JA}$  must be used. Assuming no air flow and a multi-layer board, the appropriate value is 92.4°C/W per Table 7 below.

Therefore,  $T_j$  for an ambient temperature of 70°C with all outputs switching is:

$$70^\circ C + 0.562W * 92.4^\circ C/W = 121.9^\circ C. \text{ This is below the limit of } 125^\circ C.$$

This calculation is only an example.  $T_j$  will obviously vary depending on the number of loaded outputs, supply voltage, air flow and the type of board (multi-layer).

**Table 7. Thermal Resistance  $\theta_{JA}$  for 16 Lead TSSOP, Forced Convection**

$\theta_{JA}$ vs. Air Flow			
Meters per Second	0	1	2.5
Multi-Layer PCB, JEDEC Standard Test Boards	92.4°C/W	88.0°C/W	85.9°C/W

### 3. Calculations and Equations.

The purpose of this section is to derive the power dissipated into the load.

LVPECL output driver circuit and termination are shown in *Figure 6*.

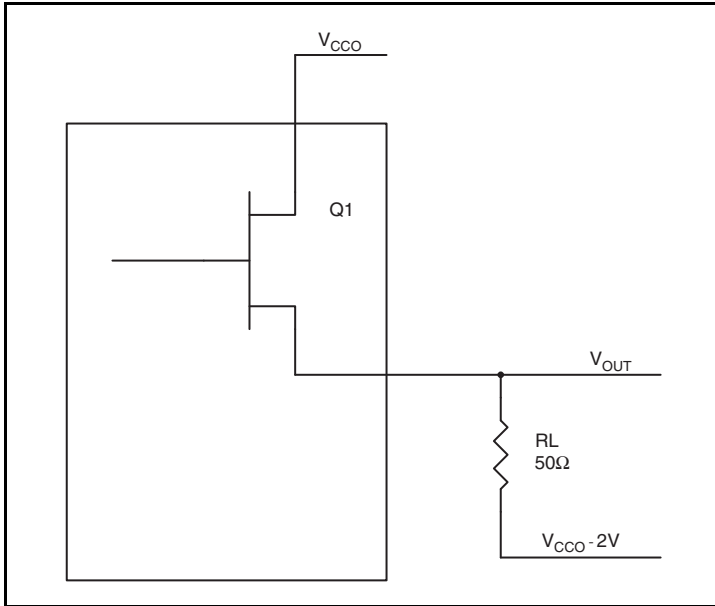

**Figure 6. LVPECL Driver Circuit and Termination**

To calculate worst case power dissipation into the load, use the following equations which assume a 50Ω load, and a termination voltage of  $V_{CCO} - 2V$ .

- For logic high,  $V_{OUT} = V_{OH\_MAX} = V_{CCO\_MAX} - 0.9V$   
 $(V_{CCO\_MAX} - V_{OH\_MAX}) = \mathbf{0.9V}$
- For logic low,  $V_{OUT} = V_{OL\_MAX} = V_{CCO\_MAX} - 1.7V$   
 $(V_{CCO\_MAX} - V_{OL\_MAX}) = \mathbf{1.7V}$

$Pd\_H$  is power dissipation when the output drives high.

$Pd\_L$  is the power dissipation when the output drives low.

$$Pd\_H = [(V_{OH\_MAX} - (V_{CCO\_MAX} - 2V))/R_L] * (V_{CCO\_MAX} - V_{OH\_MAX}) = [(2V - (V_{CCO\_MAX} - V_{OH\_MAX}))/R_L] * (V_{CCO\_MAX} - V_{OH\_MAX}) = [(2V - 0.9V)/50\Omega] * 0.9V = \mathbf{19.8mW}$$

$$Pd\_L = [(V_{OL\_MAX} - (V_{CCO\_MAX} - 2V))/R_L] * (V_{CCO\_MAX} - V_{OL\_MAX}) = [(2V - (V_{CCO\_MAX} - V_{OL\_MAX}))/R_L] * (V_{CCO\_MAX} - V_{OL\_MAX}) = [(2V - 1.7V)/50\Omega] * 1.7V = \mathbf{10.2mW}$$

Total Power Dissipation per output pair =  $Pd\_H + Pd\_L = \mathbf{30mW}$

## Reliability Information

Table 8.  $\theta_{JA}$  vs. Air Flow Table for a 16 Lead TSSOP

$\theta_{JA}$ vs. Air Flow			
Meters per Second	0	1	2.5
Multi-Layer PCB, JEDEC Standard Test Boards	92.4°C/W	88.0°C/W	85.9°C/W

## Transistor Count

The transistor count for 843252 is: 3822

## Package Outline and Package Dimensions

Package Outline - G Suffix for 16-Lead TSSOP

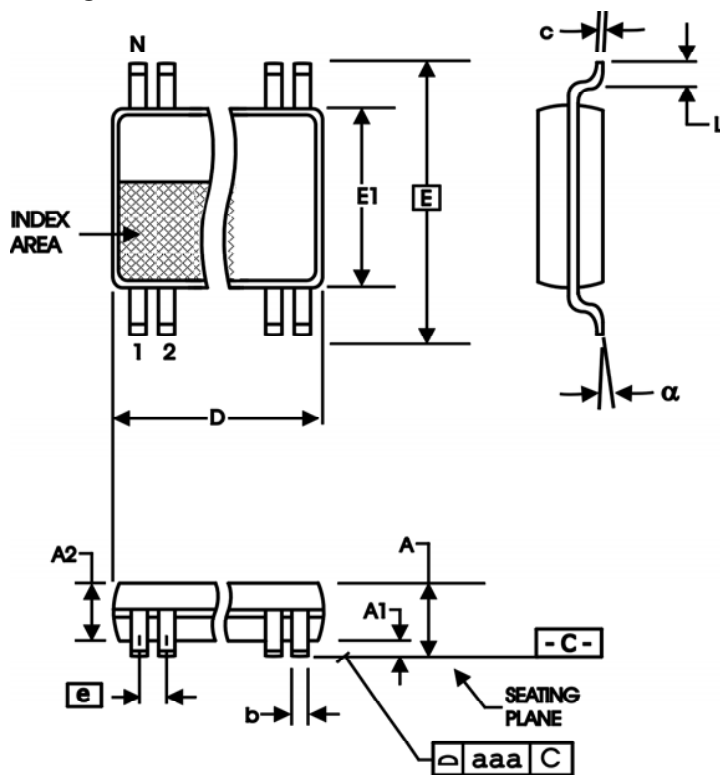

Table 9. Package Dimensions for 16 Lead TSSOP

All Dimensions in Millimeters		
Symbol	Minimum	Maximum
N	16	
A		1.20
A1	0.05	0.15
A2	0.80	1.05
b	0.19	0.30
c	0.09	0.20
D	4.90	5.10
E	6.40 Basic	
E1	4.30	4.50
e	0.65 Basic	
L	0.45	0.75
$\alpha$	0°	8°
aaa		0.10

Reference Document: JEDEC Publication 95, MO-153

## Ordering Information

Table 10. Ordering Information

Part/Order Number	Marking	Package	Shipping Packaging	Temperature
843252AGLF	843252AL	16 Lead TSSOP, Lead-Free	Tube	0°C to 70°C
843252AGLFT	843252AL	16 Lead TSSOP, Lead-Free	Tape & Reel	0°C to 70°C

## Revision History Sheet

Rev	Table	Page	Description of Change	Date
B	T10	1 15	<p>"General Description" - deleted <i>HiperClocks</i> logo and reference text.</p> <p>Ordering Information Table - deleted <i>Tape &amp; Reel count</i>.</p> <p>Deleted all <i>HiperClocks</i> references throughout the datasheet.</p> <p>Deleted <i>ICS</i> prefix from part number throughout the datasheet.</p> <p>Updated datasheet header/footer.</p>	1/19/16



**Corporate Headquarters**  
6024 Silver Creek Valley Road  
San Jose, CA 95138 USA

**Sales**  
1-800-345-7015 or 408-284-8200  
Fax: 408-284-2775  
www.IDT.com

**Tech Support**  
email: [clocks@idt.com](mailto:clocks@idt.com)

DISCLAIMER Integrated Device Technology, Inc. (IDT) and its subsidiaries reserve the right to modify the products and/or specifications described herein at any time and at IDT's sole discretion. All information in this document, including descriptions of product features and performance, is subject to change without notice. Performance specifications and the operating parameters of the described products are determined in the independent state and are not guaranteed to perform the same way when installed in customer products. The information contained herein is provided without representation or warranty of any kind, whether express or implied, including, but not limited to, the suitability of IDT's products for any particular purpose, an implied warranty of merchantability, or non-infringement of the intellectual property rights of others. This document is presented only as a guide and does not convey any license under intellectual property rights of IDT or any third parties.

IDT's products are not intended for use in applications involving extreme environmental conditions or in life support systems or similar devices where the failure or malfunction of an IDT product can be reasonably expected to significantly affect the health or safety of users. Anyone using an IDT product in such a manner does so at their own risk, absent an express, written agreement by IDT.

While the information presented herein has been checked for both accuracy and reliability, Integrated Device Technology (IDT) assumes no responsibility for either its use or for the infringement of any patents or other rights of third parties, which would result from its use. No other circuits, patents, or licenses are implied. This product is intended for use in normal commercial applications. Any other applications, such as those requiring extended temperature ranges, high reliability or other extraordinary environmental requirements are not recommended without additional processing by IDT. IDT reserves the right to change any circuitry or specifications without notice. IDT does not authorize or warrant any IDT product for use in life support devices or critical medical instruments.

Integrated Device Technology, IDT and the IDT logo are registered trademarks of IDT. Product specification subject to change without notice. Other trademarks and service marks used herein, including protected names, logos and designs, are the property of IDT or their respective third party owners.

Copyright ©2016 Integrated Device Technology, Inc. All rights reserved.

## Looking for pricing, stock, or lifecycle information?

Click below to explore more details on WIN SOURCE:

- ⊖ [View 843252AGLFT on WIN SOURCE](#)
- ⊖ [IDT, Integrated Device Technology Inc Information](#)

## Optimize Your Supply Chain with WIN SOURCE Solutions

- ✓ Global Sourcing Solution
- ✓ Obsolete Management
- ✓ Cost Control Management
- ✓ Shortage Management
- ✓ Alternative Solution
- ✓ Excess Inventory Management