

# SX-A Family FPGAs



## Leading-Edge Performance

- 250 MHz System Performance
- 350 MHz Internal Performance

## Specifications

- 12,000 to 108,000 Available System Gates
- Up to 360 User-Programmable I/O Pins
- Up to 2,012 Dedicated Flip-Flops
- 0.22  $\mu$  / 0.25  $\mu$  CMOS Process Technology

## Features

- Hot-Swap Compliant I/Os
- Power-Up/Down Friendly (No Sequencing Required for Supply Voltages)
- 66 MHz PCI Compliant
- Nonvolatile, Single-Chip Solution

- Configurable I/O Support for 3.3 V / 5 V PCI, 5 V TTL, 3.3 V LVTTTL, 2.5 V LVCMOS2
- 2.5 V, 3.3 V, and 5 V Mixed-Voltage Operation with 5 V Input Tolerance and 5 V Drive Strength
- Devices Support Multiple Temperature Grades
- Configurable Weak-Resistor Pull-Up or Pull-Down for I/O at Power-Up
- Individual Output Slew Rate Control
- Up to 100% Resource Utilization and 100% Pin Locking
- Deterministic, User-Controllable Timing
- Unique In-System Diagnostic and Verification Capability with Silicon Explorer II
- Boundary-Scan Testing in Compliance with IEEE Standard 1149.1 (JTAG)
- Actel Secure Programming Technology with FuseLock™ Prevents Reverse Engineering and Design Theft

Table 1 • SX-A Product Profile

Device	A54SX08A	A54SX16A	A54SX32A	A54SX72A
Capacity				
Typical Gates	8,000	16,000	32,000	72,000
System Gates	12,000	24,000	48,000	108,000
Logic Modules	768	1,452	2,880	6,036
Combinatorial Cells	512	924	1,800	4,024
Dedicated Flip-Flops	256	528	1,080	2,012
Maximum Flip-Flops	512 <sup>1</sup>	990	1,980	4,024
Maximum User I/Os	130	180	249	360
Global Clocks	3	3	3	3
Quadrant Clocks	0	0	0	4
Boundary Scan Testing	Yes	Yes	Yes	Yes
3.3 V / 5 V PCI	Yes	Yes	Yes	Yes
Input Set-Up (External)	0 ns	0 ns	0 ns	0 ns
Speed Grades <sup>2</sup>	-F, Std, -1, -2	-F, Std, -1, -2, -3	-F, Std, -1, -2, -3	-F, Std, -1, -2, -3
Temperature Grades	C, I, A, M	C, I, A, M	C, I, A, M	C, I, A, M
Package (by pin count)				
PQFP	208	208	208	208
TQFP	100, 144	100, 144	100, 144, 176	-
PBGA	-	-	329	-
FBGA	144	144, 256	144, 256, 484	256, 484
CQFP	-	-	208, 256	208, 256

### Notes:

1. A maximum of 512 registers is possible if all 512 C cells are used to build an additional 256 registers.
2. All -3 speed grades have been discontinued.

## Ordering Information



**Notes:**

- For more information about the CQFP package options, refer to the [HiRel SX-A datasheet](#).
- All -3 speed grades have been discontinued.

## Device Resources

Device	User I/Os (Including Clock Buffers)							
	208-Pin PQFP	100-Pin TQFP	144-Pin TQFP	176-Pin TQFP	329-Pin PBGA	144-Pin FBGA	256-Pin FBGA	484-Pin FBGA
A54SX08A	130	81	113	–	–	111	–	–
A54SX16A	175	81	113	–	–	111	180	–
A54SX32A	174	81	113	147	249	111	203	249
A54SX72A	171	–	–	–	–	–	203	360

**Notes:** Package Definitions: PQFP = Plastic Quad Flat Pack, TQFP = Thin Quad Flat Pack, PBGA = Plastic Ball Grid Array, FBGA = Fine Pitch Ball Grid Array

## Temperature Grade Offering

Package	A54SX08A	A54SX16A	A54SX32A	A54SX72A
PQ208	C,I,A,M	C,I,A,M	C,I,A,M	C,I,A,M
TQ100	C,I,A,M	C,I,A,M	C,I,A,M	
TQ144	C,I,A,M	C,I,A,M	C,I,A,M	
TQ176			C,I,M	
BG329			C,I,M	
FG144	C,I,A,M	C,I,A,M	C,I,A,M	
FG256		C,I,A,M	C,I,A,M	C,I,A,M
FG484			C,I,M	C,I,A,M
CQ208			C,M,B	C,M,B
CQ256			C,M,B	C,M,B

### Notes:

1. C = Commercial
2. I = Industrial
3. A = Automotive
4. M = Military
5. B = MIL-STD-883 Class B
6. For more information regarding automotive products, refer to the [SX-A Automotive Family FPGAs datasheet](#).
7. For more information regarding Mil-Temp and ceramic packages, refer to the [HiRel SX-A Family FPGAs datasheet](#).

## Speed Grade and Temperature Grade Matrix

	F	Std	-1	-2	-3
Commercial	✓	✓	✓	✓	Discontinued
Industrial		✓	✓	✓	Discontinued
Automotive		✓			
Military		✓	✓		
MIL-STD-883B		✓	✓		

### Notes:

1. For more information regarding automotive products, refer to the [SX-A Automotive Family FPGAs datasheet](#).
2. For more information regarding Mil-Temp and ceramic packages, refer to the [HiRel SX-A Family FPGAs datasheet](#).

Contact your Actel Sales representative for more information on availability.

# Table of Contents

## General Description

Introduction .....	1-1
SX-A Family Architecture .....	1-1
Other Architectural Features .....	1-7
Programming .....	1-13
Related Documents .....	1-14
Pin Description .....	1-15

## Detailed Specifications

Operating Conditions .....	2-1
Typical SX-A Standby Current .....	2-1
Electrical Specifications .....	2-2
PCI Compliance for the SX-A Family .....	2-3
Thermal Characteristics .....	2-11
SX-A Timing Model .....	2-14
Sample Path Calculations .....	2-14
Output Buffer Delays .....	2-15
AC Test Loads .....	2-15
Input Buffer Delays .....	2-16
C-Cell Delays .....	2-16
Cell Timing Characteristics .....	2-16
Timing Characteristics .....	2-17
Temperature and Voltage Derating Factors .....	2-17
Timing Characteristics .....	2-18

## Package Pin Assignments

208-Pin PQFP .....	3-1
100-Pin TQFP .....	3-5
144-Pin TQFP .....	3-8
176-Pin TQFP .....	3-11
329-Pin PBGA .....	3-14
144-Pin FBGA .....	3-18
256-Pin FBGA .....	3-21
484-Pin FBGA .....	3-26

## Datasheet Information

List of Changes .....	4-1
Datasheet Categories .....	4-3
International Traffic in Arms Regulations (ITAR) and Export Administration Regulations (EAR) .....	4-3

# General Description

## Introduction

The Actel SX-A family of FPGAs offers a cost-effective, single-chip solution for low-power, high-performance designs. Fabricated on 0.22  $\mu\text{m}$  / 0.25  $\mu\text{m}$  CMOS antifuse technology and with the support of 2.5 V, 3.3 V and 5 V I/Os, the SX-A is a versatile platform to integrate designs while significantly reducing time-to-market.

## SX-A Family Architecture

The SX-A family's device architecture provides a unique approach to module organization and chip routing that satisfies performance requirements and delivers the most optimal register/logic mix for a wide variety of applications.

Interconnection between these logic modules is achieved using Actel's patented metal-to-metal programmable antifuse interconnect elements (Figure 1-1). The antifuses are normally open circuit and, when programmed, form a permanent low-impedance connection.

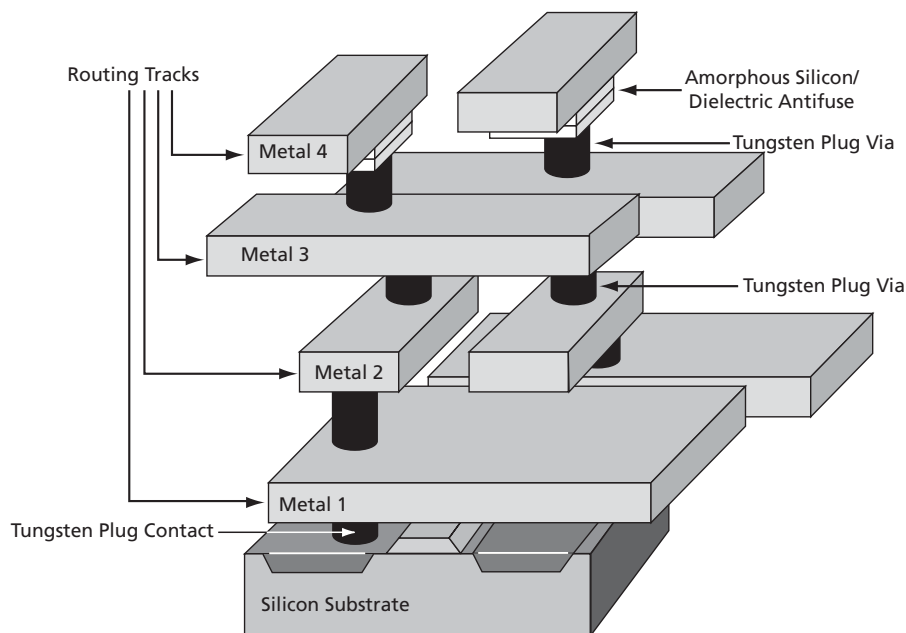

**Note:** The A54SX72A device has four layers of metal with the antifuse between Metal 3 and Metal 4. The A54SX08A, A54SX16A, and A54SX32A devices have three layers of metal with the antifuse between Metal 2 and Metal 3.

Figure 1-1 • SX-A Family Interconnect Elements

## Logic Module Design

The SX-A family architecture is described as a “sea-of-modules” architecture because the entire floor of the device is covered with a grid of logic modules with virtually no chip area lost to interconnect elements or routing. The Actel SX-A family provides two types of logic modules: the register cell (R-cell) and the combinatorial cell (C-cell).

The R-cell contains a flip-flop featuring asynchronous clear, asynchronous preset, and clock enable, using the S0 and S1 lines control signals (Figure 1-2). The R-cell registers feature programmable clock polarity selectable on a register-by-register basis. This provides additional flexibility while allowing mapping of synthesized functions into the SX-A FPGA. The clock source for the R-cell can be chosen from either the hardwired clock, the routed clocks, or internal logic.

The C-cell implements a range of combinatorial functions of up to five inputs (Figure 1-3). Inclusion of the DB input and its associated inverter function allows up to 4,000

different combinatorial functions to be implemented in a single module. An example of the flexibility enabled by the inversion capability is the ability to integrate a 3-input exclusive-OR function into a single C-cell. This facilitates construction of 9-bit parity-tree functions with 1.9 ns propagation delays.

## Module Organization

All C-cell and R-cell logic modules are arranged into horizontal banks called Clusters. There are two types of Clusters: Type 1 contains two C-cells and one R-cell, while Type 2 contains one C-cell and two R-cells.

Clusters are grouped together into SuperClusters (Figure 1-4 on page 1-3). SuperCluster 1 is a two-wide grouping of Type 1 Clusters. SuperCluster 2 is a two-wide group containing one Type 1 Cluster and one Type 2 Cluster. SX-A devices feature more SuperCluster 1 modules than SuperCluster 2 modules because designers typically require significantly more combinatorial logic than flip-flops.

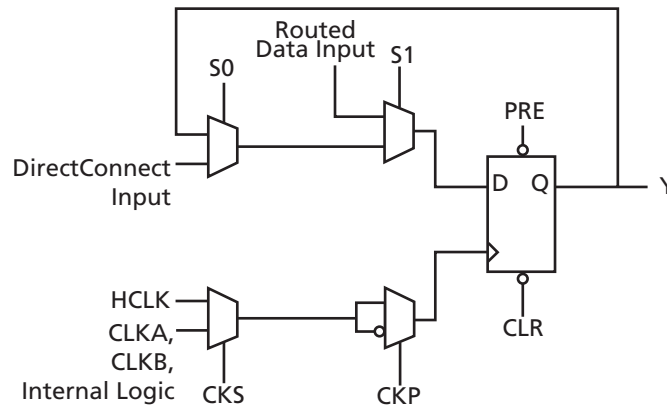

Figure 1-2 • R-Cell



Figure 1-3 • C-Cell

## Routing Resources

The routing and interconnect resources of SX-A devices are in the top two metal layers above the logic modules (Figure 1-1 on page 1-1), providing optimal use of silicon, thus enabling the entire floor of the device to be spanned with an uninterrupted grid of logic modules. Interconnection between these logic modules is achieved using the Actel patented metal-to-metal programmable antifuse interconnect elements. The antifuses are normally open circuits and, when programmed, form a permanent low-impedance connection.

Clusters and SuperClusters can be connected through the use of two innovative local routing resources called FastConnect and DirectConnect, which enable extremely fast and predictable interconnection of modules within Clusters and SuperClusters (Figure 1-5 on page 1-4 and Figure 1-6 on page 1-4). This routing architecture also dramatically reduces the number of antifuses required to complete a circuit, ensuring the highest possible performance, which is often required in applications such as fast counters, state machines, and data path logic. The interconnect elements (i.e., the antifuses and metal tracks) have lower capacitance and lower resistance than any other device of similar capacity, leading to the fastest signal propagation in the industry.

DirectConnect is a horizontal routing resource that provides connections from a C-cell to its neighboring R-Cell in a given SuperCluster. DirectConnect uses a hardwired signal path requiring no programmable

interconnection to achieve its fast signal propagation time of less than 0.1 ns.

FastConnect enables horizontal routing between any two logic modules within a given SuperCluster, and vertical routing with the SuperCluster immediately below it. Only one programmable connection is used in a FastConnect path, delivering a maximum pin-to-pin propagation time of 0.3 ns.

In addition to DirectConnect and FastConnect, the architecture makes use of two globally oriented routing resources known as segmented routing and high-drive routing. The Actel segmented routing structure provides a variety of track lengths for extremely fast routing between SuperClusters. The exact combination of track lengths and antifuses within each path is chosen by the 100% automatic place-and-route software to minimize signal propagation delays.

The general system of routing tracks allows any logic module in the array to be connected to any other logic or I/O module. Within this system, most connections typically require three or fewer antifuses, resulting in fast and predictable performance.

The unique local and general routing structure featured in SX-A devices allows 100% pin-locking with full logic utilization, enables concurrent printed circuit board (PCB) development, reduces design time, and allows designers to achieve performance goals with minimum effort.



Figure 1-4 • Cluster Organization



Figure 1-5 • DirectConnect and FastConnect for Type 1 SuperClusters



Figure 1-6 • DirectConnect and FastConnect for Type 2 SuperClusters

## Clock Resources

Actel's high-drive routing structure provides three clock networks (Table 1-1). The first clock, called HCLK, is hardwired from the HCLK buffer to the clock select multiplexer (MUX) in each R-cell. HCLK cannot be connected to combinatorial logic. This provides a fast propagation path for the clock signal. If not used, this pin must be set as Low or High on the board. It must not be left floating. Figure 1-7 describes the clock circuit used for the constant load HCLK and the macros supported.

HCLK does not function until the fourth clock cycle each time the device is powered up to prevent false output levels due to any possible slow power-on-reset signal and fast start-up clock circuit. To activate HCLK from the first cycle, the TRST pin must be reserved in the Design software and the pin must be tied to GND on the board.

Two additional clocks (CLKA, CLKB) are global clocks that can be sourced from external pins or from internal logic signals within the SX-A device. CLKA and CLKB may be connected to sequential cells or to combinatorial logic. If CLKA or CLKB pins are not used or sourced from signals, these pins must be set as Low or High on the board. They must not be left floating. Figure 1-8 describes the CLKA

and CLKB circuit used and the macros supported in SX-A devices with the exception of A54SX72A.

In addition, the A54SX72A device provides four quadrant clocks (QCLKA, QCLKB, QCLKC, and QCLKD—corresponding to bottom-left, bottom-right, top-left, and top-right locations on the die, respectively), which can be sourced from external pins or from internal logic signals within the device. Each of these clocks can individually drive up to an entire quadrant of the chip, or they can be grouped together to drive multiple quadrants (Figure 1-9 on page 1-6). QCLK pins can function as user I/O pins. If not used, the QCLK pins must be tied Low or High on the board and must not be left floating.

For more information on how to use quadrant clocks in the A54SX72A device, refer to the *Global Clock Networks in Actel's Antifuse Devices* and *Using A54SX72A and RT54SX72S Quadrant Clocks* application notes.

The CLKA, CLKB, and QCLK circuits for A54SX72A as well as the macros supported are shown in Figure 1-10 on page 1-6. Note that bidirectional clock buffers are only available in A54SX72A. For more information, refer to the "Pin Description" section on page 1-15.

Table 1-1 • SX-A Clock Resources

	A54SX08A	A54SX16A	A54SX32A	A54SX72A
Routed Clocks (CLKA, CLKB)	2	2	2	2
Hardwired Clocks (HCLK)	1	1	1	1
Quadrant Clocks (QCLKA, QCLKB, QCLKC, QCLKD)	0	0	0	4

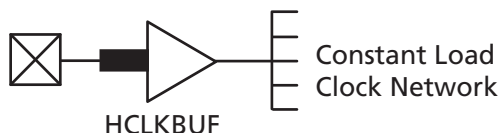

Figure 1-7 • SX-A HCLK Clock Buffer

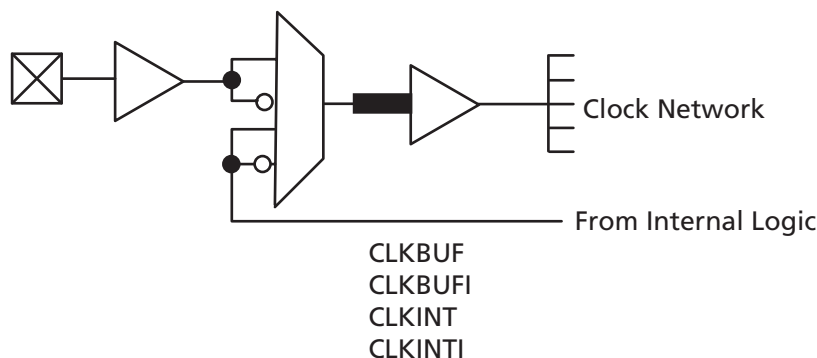

Figure 1-8 • SX-A Routed Clock Buffer



Figure 1-9 • SX-A QCLK Architecture



Figure 1-10 • A54SX72A Routed Clock and QCLK Buffer

## Other Architectural Features

### Technology

The Actel SX-A family is implemented on a high-voltage, twin-well CMOS process using 0.22  $\mu$  / 0.25  $\mu$  design rules. The metal-to-metal antifuse is comprised of a combination of amorphous silicon and dielectric material with barrier metals and has a programmed ('on' state) resistance of 25  $\Omega$  with capacitance of 1.0 fF for low signal impedance.

### Performance

The unique architectural features of the SX-A family enable the devices to operate with internal clock frequencies of 350 MHz, causing very fast execution of even complex logic functions. The SX-A family is an optimal platform upon which to integrate the functionality previously contained in multiple complex programmable logic devices (CPLDs). In addition, designs that previously would have required a gate array to meet performance goals can be integrated into an SX-A device with dramatic improvements in cost and time-to-market. Using timing-driven place-and-route tools, designers can achieve highly deterministic device performance.

### User Security

Reverse engineering is virtually impossible in SX-A devices because it is extremely difficult to distinguish between programmed and unprogrammed antifuses. In addition, since SX-A is a nonvolatile, single-chip solution, there is no configuration bitstream to intercept at device power-up.

The Actel FuseLock advantage ensures that unauthorized users will not be able to read back the contents of an Actel antifuse FPGA. In addition to the inherent strengths of the architecture, special security fuses that prevent internal probing and overwriting are hidden throughout the fabric of the device. They are located where they cannot be accessed or bypassed without destroying access to the rest of the device, making both invasive and more-subtle noninvasive attacks ineffective against Actel antifuse FPGAs.

Look for this symbol to ensure your valuable IP is secure (Figure 1-11).



Figure 1-11 • FuseLock

For more information, refer to Actel's *Implementation of Security in Actel Antifuse FPGAs* application note.

## I/O Modules

For a simplified I/O schematic, refer to Figure 1 in the application note, *Actel eX, SX-A, and RTSX-S I/Os*.

Each user I/O on an SX-A device can be configured as an input, an output, a tristate output, or a bidirectional pin. Mixed I/O standards can be set for individual pins, though this is only allowed with the same voltage as the input. These I/Os, combined with array registers, can achieve clock-to-output-pad timing as fast as 3.8 ns, even without the dedicated I/O registers. In most FPGAs, I/O cells that have embedded latches and flip-flops, requiring instantiation in HDL code; this is a design complication not encountered in SX-A FPGAs. Fast pin-to-pin timing ensures that the device is able to interface with any other device in the system, which in turn enables parallel design of system components and reduces overall design time. All unused I/Os are configured as tristate outputs by the Actel Designer software, for maximum flexibility when designing new boards or migrating existing designs.

SX-A I/Os should be driven by high-speed push-pull devices with a low-resistance pull-up device when being configured as tristate output buffers. If the I/O is driven by a voltage level greater than  $V_{CC1}$  and a fast push-pull device is NOT used, the high-resistance pull-up of the driver and the internal circuitry of the SX-A I/O may create a voltage divider. This voltage divider could pull the input voltage below specification for some devices connected to the driver. A logic '1' may not be correctly presented in this case. For example, if an open drain driver is used with a pull-up resistor to 5 V to provide the logic '1' input, and  $V_{CC1}$  is set to 3.3 V on the SX-A device, the input signal may be pulled down by the SX-A input.

Each I/O module has an available power-up resistor of approximately 50 k $\Omega$  that can configure the I/O in a known state during power-up. For nominal pull-up and pull-down resistor values, refer to Table 1-4 on page 1-8 of the application note *Actel eX, SX-A, and RTSX-S I/Os*. Just slightly before  $V_{CCA}$  reaches 2.5 V, the resistors are disabled, so the I/Os will be controlled by user logic. See Table 1-2 on page 1-8 and Table 1-3 on page 1-8 for more information concerning available I/O features.

## Power-Up/Down and Hot Swapping

SX-A I/Os are configured to be hot-swappable, with the exception of 3.3 V PCI. During power-up/down (or partial up/down), all I/Os are tristated.  $V_{CCA}$  and  $V_{CCI}$  do not have to be stable during power-up/down, and can be powered up/down in any order. When the SX-A device is plugged into an electrically active system, the device will not degrade the reliability of or cause damage to the host system. The device's output pins are driven to a high impedance state until normal chip operating conditions

are reached. Table 1-4 summarizes the  $V_{CCA}$  voltage at which the I/Os behave according to the user's design for an SX-A device at room temperature for various ramp-up rates. The data reported assumes a linear ramp-up profile to 2.5 V. For more information on power-up and hot-swapping, refer to the application note, [Actel SX-A and RT54SX-S Devices in Hot-Swap and Cold-Sparing Applications](#).

Table 1-2 • I/O Features

Function	Description
Input Buffer Threshold Selections	<ul style="list-style-type: none"> <li>5 V: PCI, TTL</li> <li>3.3 V: PCI, LVTTTL</li> <li>2.5 V: LVCMOS2 (commercial only)</li> </ul>
Flexible Output Driver	<ul style="list-style-type: none"> <li>5 V: PCI, TTL</li> <li>3.3 V: PCI, LVTTTL</li> <li>2.5 V: LVCMOS2 (commercial only)</li> </ul>
Output Buffer	<p>"Hot-Swap" Capability (3.3 V PCI is not hot swappable)</p> <ul style="list-style-type: none"> <li>I/O on an unpowered device does not sink current</li> <li>Can be used for "cold-sparing"</li> </ul> <p>Selectable on an individual I/O basis</p> <p>Individually selectable slew rate; high slew or low slew (The default is high slew rate). The slew is only affected on the falling edge of an output. Rising edges of outputs are not affected.</p>
Power-Up	<p>Individually selectable pull-ups and pull-downs during power-up (default is to power-up in tristate)</p> <p>Enables deterministic power-up of device</p> <p><math>V_{CCA}</math> and <math>V_{CCI}</math> can be powered in any order</p>

Table 1-3 • I/O Characteristics for All I/O Configurations

	Hot Swappable	Slew Rate Control	Power-Up Resistor
TTL, LVTTTL, LVCMOS2	Yes	Yes. Only affects falling edges of outputs	Pull-up or pull-down
3.3 V PCI	No	No. High slew rate only	Pull-up or pull-down
5 V PCI	Yes	No. High slew rate only	Pull-up or pull-down

Table 1-4 • Power-Up Time at which I/Os Become Active

Supply Ramp Rate	0.25 V/ $\mu$ s	0.025 V/ $\mu$ s	5 V/ms	2.5 V/ms	0.5 V/ms	0.25 V/ms	0.1 V/ms	0.025 V/ms
Units	$\mu$ s	$\mu$ s	ms	ms	ms	ms	ms	ms
A54SX08A	10	96	0.34	0.65	2.7	5.4	12.9	50.8
A54SX16A	10	100	0.36	0.62	2.5	4.7	11.0	41.6
A54SX32A	10	100	0.46	0.74	2.8	5.2	12.1	47.2
A54SX72A	10	100	0.41	0.67	2.6	5.0	12.1	47.2

## Boundary-Scan Testing (BST)

All SX-A devices are IEEE 1149.1 compliant and offer superior diagnostic and testing capabilities by providing Boundary Scan Testing (BST) and probing capabilities. The BST function is controlled through the special JTAG pins (TMS, TDI, TCK, TDO, and TRST). The functionality of the JTAG pins is defined by two available modes: Dedicated and Flexible. TMS cannot be employed as a user I/O in either mode.

### Dedicated Mode

In Dedicated mode, all JTAG pins are reserved for BST; designers cannot use them as regular I/Os. An internal pull-up resistor is automatically enabled on both TMS and TDI pins, and the TMS pin will function as defined in the IEEE 1149.1 (JTAG) specification.

To select Dedicated mode, the user must reserve the JTAG pins in Actel's Designer software. Reserve the JTAG pins by checking the **Reserve JTAG** box in the Device Selection Wizard (Figure 1-12).

The default for the software is Flexible mode; all boxes are unchecked. Table 1-5 lists the definitions of the options in the Device Selection Wizard.



Figure 1-12 • Device Selection Wizard

Table 1-5 • Reserve Pin Definitions

Pin	Function
Reserve JTAG	Keeps pins from being used and changes the behavior of JTAG pins (no pull-up on TMS)
Reserve JTAG Test Reset	Regular I/O or JTAG reset with an internal pull-up
Reserve Probe	Keeps pins from being used or regular I/O

### Flexible Mode

In Flexible mode, TDI, TCK, and TDO may be employed as either user I/Os or as JTAG input pins. The internal resistors on the TMS and TDI pins are not present in flexible JTAG mode.

To select the Flexible mode, uncheck the **Reserve JTAG** box in the Device Selection Wizard dialog in the Actel Designer software. In Flexible mode, TDI, TCK, and TDO pins may function as user I/Os or BST pins. The functionality is controlled by the BST Test Access Port (TAP) controller. The TAP controller receives two control inputs, TMS and TCK. Upon power-up, the TAP controller enters the Test-Logic-Reset state. In this state, TDI, TCK, and TDO function as user I/Os. The TDI, TCK, and TDO are transformed from user I/Os into BST pins when a rising edge on TCK is detected while TMS is at logic low. To return to Test-Logic Reset state, TMS must be high for at least five TCK cycles. **An external 10 k pull-up resistor to V<sub>CC</sub> should be placed on the TMS pin to pull it High by default.**

Table 1-6 describes the different configuration requirements of BST pins and their functionality in different modes.

Table 1-6 • Boundary-Scan Pin Configurations and Functions

Mode	Designer "Reserve JTAG" Selection	TAP Controller State
Dedicated (JTAG)	Checked	Any
Flexible (User I/O)	Unchecked	Test-Logic-Reset
Flexible (JTAG)	Unchecked	Any EXCEPT Test-Logic-Reset

### TRST Pin

The TRST pin functions as a dedicated Boundary-Scan Reset pin when the **Reserve JTAG Test Reset** option is selected as shown in Figure 1-12. An internal pull-up resistor is permanently enabled on the TRST pin in this mode. Actel recommends connecting this pin to ground in normal operation to keep the JTAG state controller in the Test-Logic-Reset state. When JTAG is being used, it can be left floating or can be driven high.

When the **Reserve JTAG Test Reset** option is not selected, this pin will function as a regular I/O. If unused as an I/O in the design, it will be configured as a tristated output.

## JTAG Instructions

Table 1-7 lists the supported instructions with the corresponding IR codes for SX-A devices.

Table 1-8 lists the codes returned after executing the IDCODE instruction for SX-A devices. Note that bit 0 is always '1'. Bits 11-1 are always '02F', which is the Actel manufacturer code.

Table 1-7 • JTAG Instruction Code

Instructions (IR4:IR0)	Binary Code
EXTEST	00000
SAMPLE/PRELOAD	00001
INTEST	00010
USERCODE	00011
IDCODE	00100
HighZ	01110
CLAMP	01111
Diagnostic	10000
BYPASS	11111
Reserved	All others

Table 1-8 • JTAG Instruction Code

Device	Process	Revision	Bits 31-28	Bits 27-12
A54SX08A	0.22 $\mu$	0	8, 9	40B4, 42B4
		1	A, B	40B4, 42B4
A54SX16A	0.22 $\mu$	0	9	40B8, 42B8
		1	B	40B8, 42B8
	0.25 $\mu$	1	B	22B8
A54SX32A	0.2 2 $\mu$	0	9	40BD, 42BD
		1	B	40BD, 42BD
	0.25 $\mu$	1	B	22BD
A54SX72A	0.22 $\mu$	0	9	40B2, 42B2
		1	B	40B2, 42B2
	0.25 $\mu$	1	B	22B2

## Probing Capabilities

SX-A devices also provide an internal probing capability that is accessed with the JTAG pins. The Silicon Explorer II diagnostic hardware is used to control the TDI, TCK, TMS, and TDO pins to select the desired nets for debugging. The user assigns the selected internal nets in Actel Silicon Explorer II software to the PRA/PRB output pins for observation. Silicon Explorer II automatically places the device into JTAG mode. However, probing functionality is only activated when the TRST pin is driven high or left floating, allowing the internal pull-up resistor to pull TRST High. If the TRST pin is held Low, the TAP controller remains in the Test-Logic-Reset state so no probing can be performed. However, the user must drive the TRST pin High or allow the internal pull-up resistor to pull TRST High.

When selecting the **Reserve Probe Pin** box as shown in [Figure 1-12 on page 1-9](#), direct the layout tool to reserve the PRA and PRB pins as dedicated outputs for probing. This **Reserve** option is merely a guideline. If the designer assigns user I/Os to the PRA and PRB pins and selects the **Reserve Probe Pin** option, Designer Layout will override the **Reserve Probe Pin** option and place the user I/Os on those pins.

To allow probing capabilities, the security fuse must not be programmed. Programming the security fuse disables the JTAG and probe circuitry. [Table 1-9](#) summarizes the possible device configurations for probing once the device leaves the Test-Logic-Reset JTAG state.

Table 1-9 • Device Configuration Options for Probe Capability (TRST Pin Reserved)

JTAG Mode	TRST <sup>1</sup>	Security Fuse Programmed	PRA, PRB <sup>2</sup>	TDI, TCK, TDO <sup>2</sup>
Dedicated	Low	No	User I/O <sup>3</sup>	JTAG Disabled
	High	No	Probe Circuit Outputs	JTAG I/O
Flexible	Low	No	User I/O <sup>3</sup>	User I/O <sup>3</sup>
	High	No	Probe Circuit Outputs	JTAG I/O
		Yes	Probe Circuit Secured	Probe Circuit Secured

**Notes:**

1. If the TRST pin is not reserved, the device behaves according to TRST = High as described in the table.
2. Avoid using the TDI, TCK, TDO, PRA, and PRB pins as input or bidirectional ports. Since these pins are active during probing, input signals will not pass through these pins and may cause contention.
3. If no user signal is assigned to these pins, they will behave as unused I/Os in this mode. Unused pins are automatically tristated by the Designer software.

### SX-A Probe Circuit Control Pins

SX-A devices contain internal probing circuitry that provides built-in access to every node in a design, enabling 100% real-time observation and analysis of a device's internal logic nodes without design iteration. The probe circuitry is accessed by Silicon Explorer II, an easy to use, integrated verification and logic analysis tool that can sample data at 100 MHz (asynchronous) or 66 MHz (synchronous). Silicon Explorer II attaches to a PC's standard COM port, turning the PC into a fully functional 18-channel logic analyzer. Silicon Explorer II allows designers to complete the design verification process at their desks and reduces verification time from several hours per cycle to a few seconds.

The Silicon Explorer II tool uses the boundary-scan ports (TDI, TCK, TMS, and TDO) to select the desired nets for verification. The selected internal nets are assigned to the

PRA/PRB pins for observation. Figure 1-13 illustrates the interconnection between Silicon Explorer II and the FPGA to perform in-circuit verification.

### Design Considerations

In order to preserve device probing capabilities, users should avoid using the TDI, TCK, TDO, PRA, and PRB pins as input or bidirectional ports. Since these pins are active during probing, critical input signals through these pins are not available. In addition, the security fuse must not be programmed to preserve probing capabilities. Actel recommends that you use a 70 Ω series termination resistor on every probe connector (TDI, TCK, TMS, TDO, PRA, PRB). The 70 Ω series termination is used to prevent data transmission corruption during probing and reading back the checksum.



Figure 1-13 • Probe Setup

## Design Environment

The SX-A family of FPGAs is fully supported by both Actel Libero® Integrated Design Environment (IDE) and Designer FPGA development software. Actel Libero IDE is a design management environment, seamlessly integrating design tools while guiding the user through the design flow, managing all design and log files, and passing necessary design data among tools. Additionally, Libero IDE allows users to integrate both schematic and HDL synthesis into a single flow and verify the entire design in a single environment. Libero IDE includes Synplify® for Actel from Synplicity®, ViewDraw® for Actel from Mentor Graphics®, ModelSim® HDL Simulator from Mentor Graphics, WaveFormer Lite™ from SynaptiCAD™, and Designer software from Actel. Refer to the *Libero IDE flow* diagram for more information (located on the Actel website).

Actel Designer software is a place-and-route tool and provides a comprehensive suite of backend support tools for FPGA development. The Designer software includes timing-driven place-and-route, and a world-class integrated static timing analyzer and constraints editor. With the Designer software, a user can select and lock package pins while only minimally impacting the results of place-and-route. Additionally, the back-annotation flow is compatible with all the major simulators and the simulation results can be cross-probed with Silicon Explorer II, Actel's integrated verification and logic analysis tool. Another tool included in the Designer software is the SmarGen core generator, which easily creates popular and commonly used logic functions for implementation in your schematic or HDL design. Actel's Designer software is compatible with the most popular FPGA design entry and verification tools from companies such as Mentor Graphics, Synplicity, Synopsys, and Cadence Design Systems. The Designer software is available for both the Windows and UNIX operating systems.

## Programming

Device programming is supported through Silicon Sculptor series of programmers. In particular, Silicon Sculptor is compact, robust, single-site and multi-site device programmer for the PC.

With standalone software, Silicon Sculptor allows concurrent programming of multiple units from the same PC, ensuring the fastest programming times possible. Each fuse is subsequently verified by Silicon Sculptor II to insure correct programming. In addition, integrity tests ensure that no extra fuses are programmed. Silicon Sculptor also provides extensive hardware self-testing capability.

The procedure for programming an SX-A device using Silicon Sculptor is as follows:

1. Load the .AFM file
2. Select the device to be programmed
3. Begin programming

When the design is ready to go to production, Actel offers device volume-programming services either through distribution partners or via in-house programming from the factory.

For detailed information on programming, read the following documents *Programming Antifuse Devices* and *Silicon Sculptor User's Guide*.

## Related Documents

### Application Notes

*Global Clock Networks in Actel's Antifuse Devices*

[http://www.actel.com/documents/GlobalClk\\_AN.pdf](http://www.actel.com/documents/GlobalClk_AN.pdf)

*Using A54SX72A and RT54SX72S Quadrant Clocks*

[http://www.actel.com/documents/QCLK\\_AN.pdf](http://www.actel.com/documents/QCLK_AN.pdf)

*Implementation of Security in Actel Antifuse FPGAs*

[http://www.actel.com/documents/Antifuse\\_Security\\_AN.pdf](http://www.actel.com/documents/Antifuse_Security_AN.pdf)

*Actel eX, SX-A, and RTSX-S I/Os*

[http://www.actel.com/documents/AntifuseIO\\_AN.pdf](http://www.actel.com/documents/AntifuseIO_AN.pdf)

*Actel SX-A and RT54SX-S Devices in Hot-Swap and Cold-Sparing Applications*

[http://www.actel.com/documents/HotSwapColdSparing\\_AN.pdf](http://www.actel.com/documents/HotSwapColdSparing_AN.pdf)

*Programming Antifuse Devices*

[http://www.actel.com/documents/AntifuseProgram\\_AN.pdf](http://www.actel.com/documents/AntifuseProgram_AN.pdf)

### Datasheets

*HiRel SX-A Family FPGAs*

[http://www.actel.com/documents/HRSXA\\_DS.pdf](http://www.actel.com/documents/HRSXA_DS.pdf)

*SX-A Automotive Family FPGAs*

[http://www.actel.com/documents/SXA\\_Auto\\_DS.pdf](http://www.actel.com/documents/SXA_Auto_DS.pdf)

### User's Guides

*Silicon Sculptor User's Guide*

[http://www.actel.com/documents/SiliSculptII\\_Sculpt3\\_ug.pdf](http://www.actel.com/documents/SiliSculptII_Sculpt3_ug.pdf)

## Pin Description

### CLKA/B, I/O      Clock A and B

These pins are clock inputs for clock distribution networks. Input levels are compatible with standard TTL, LVTTTL, LVCMOS2, 3.3 V PCI, or 5 V PCI specifications. The clock input is buffered prior to clocking the R-cells. When not used, this pin must be tied Low or High (NOT left floating) on the board to avoid unwanted power consumption.

For A54SX72A, these pins can also be configured as user I/Os. When employed as user I/Os, these pins offer built-in programmable pull-up or pull-down resistors active during power-up only. When not used, these pins must be tied Low or High (NOT left floating).

### QCLKA/B/C/D, I/O      Quadrant Clock A, B, C, and D

These four pins are the quadrant clock inputs and are only used for A54SX72A with A, B, C, and D corresponding to bottom-left, bottom-right, top-left, and top-right quadrants, respectively. They are clock inputs for clock distribution networks. Input levels are compatible with standard TTL, LVTTTL, LVCMOS2, 3.3 V PCI, or 5 V PCI specifications. Each of these clock inputs can drive up to a quarter of the chip, or they can be grouped together to drive multiple quadrants. The clock input is buffered prior to clocking the R-cells. When not used, these pins must be tied Low or High on the board (NOT left floating).

These pins can also be configured as user I/Os. When employed as user I/Os, these pins offer built-in programmable pull-up or pull-down resistors active during power-up only.

### GND      Ground

Low supply voltage.

### HCLK      Dedicated (Hardwired) Array Clock

This pin is the clock input for sequential modules. Input levels are compatible with standard TTL, LVTTTL, LVCMOS2, 3.3 V PCI, or 5 V PCI specifications. This input is directly wired to each R-cell and offers clock speeds independent of the number of R-cells being driven. When not used, HCLK must be tied Low or High on the board (NOT left floating). When used, this pin should be held Low or High during power-up to avoid unwanted static power consumption.

### I/O      Input/Output

The I/O pin functions as an input, output, tristate, or bidirectional buffer. Based on certain configurations, input and output levels are compatible with standard TTL, LVTTTL, LVCMOS2, 3.3 V PCI or 5 V PCI specifications. Unused I/O pins are automatically tristated by the Designer software.

### NC      No Connection

This pin is not connected to circuitry within the device and can be driven to any voltage or be left floating with no effect on the operation of the device.

### PRA/B, I/O      Probe A/B

The Probe pin is used to output data from any user-defined design node within the device. This independent diagnostic pin can be used in conjunction with the other probe pin to allow real-time diagnostic output of any signal path within the device. The Probe pin can be used as a user-defined I/O when verification has been completed. The pin's probe capabilities can be permanently disabled to protect programmed design confidentiality.

### TCK, I/O      Test Clock

Test clock input for diagnostic probe and device programming. In Flexible mode, TCK becomes active when the TMS pin is set Low (refer to [Table 1-6 on page 1-9](#)). This pin functions as an I/O when the boundary scan state machine reaches the "logic reset" state.

### TDI, I/O      Test Data Input

Serial input for boundary scan testing and diagnostic probe. In Flexible mode, TDI is active when the TMS pin is set Low (refer to [Table 1-6 on page 1-9](#)). This pin functions as an I/O when the boundary scan state machine reaches the "logic reset" state.

### TDO, I/O      Test Data Output

Serial output for boundary scan testing. In flexible mode, TDO is active when the TMS pin is set Low (refer to [Table 1-6 on page 1-9](#)). This pin functions as an I/O when the boundary scan state machine reaches the "logic reset" state. When Silicon Explorer II is being used, TDO will act as an output when the checksum command is run. It will return to user I/O when checksum is complete.

### TMS      Test Mode Select

The TMS pin controls the use of the IEEE 1149.1 Boundary Scan pins (TCK, TDI, TDO, TRST). In flexible mode when the TMS pin is set Low, the TCK, TDI, and TDO pins are boundary scan pins (refer to [Table 1-6 on page 1-9](#)). Once the boundary scan pins are in test mode, they will remain in that mode until the internal boundary scan state machine reaches the logic reset state. At this point, the boundary scan pins will be released and will function as regular I/O pins. The logic reset state is reached five TCK cycles after the TMS pin is set High. In dedicated test mode, TMS functions as specified in the IEEE 1149.1 specifications.

### TRST, I/O      Boundary Scan Reset Pin

Once it is configured as the JTAG Reset pin, the TRST pin functions as an active low input to asynchronously initialize or reset the boundary scan circuit. The TRST pin is equipped with an internal pull-up resistor. This pin functions as an I/O when the **Reserve JTAG Reset Pin** is not selected in Designer.

### V<sub>CCI</sub>      Supply Voltage

Supply voltage for I/Os. See [Table 2-2 on page 2-1](#). All V<sub>CCI</sub> power pins in the device should be connected.

### V<sub>CCA</sub>      Supply Voltage

Supply voltage for array. See [Table 2-2 on page 2-1](#). All V<sub>CCA</sub> power pins in the device should be connected.



# Detailed Specifications

## Operating Conditions

Table 2-1 • Absolute Maximum Ratings

Symbol	Parameter	Limits	Units
$V_{CCI}$	DC Supply Voltage for I/Os	-0.3 to +6.0	V
$V_{CCA}$	DC Supply Voltage for Arrays	-0.3 to +3.0	V
$V_I$	Input Voltage	-0.5 to +5.75	V
$V_O$	Output Voltage	-0.5 to $+V_{CCI} + 0.5$	V
$T_{STG}$	Storage Temperature	-65 to +150	°C

**Note:** \*Stresses beyond those listed under "Absolute Maximum Ratings" may cause permanent damage to the device. Exposure to absolute maximum rated conditions for extended periods may affect device reliability. Devices should not be operated outside the "Recommended Operating Conditions".

Table 2-2 • Recommended Operating Conditions

Parameter	Commercial	Industrial	Units
Temperature Range	0 to +70	-40 to +85	°C
2.5 V Power Supply Range ( $V_{CCA}$ and $V_{CCI}$ )	2.25 to 2.75	2.25 to 2.75	V
3.3 V Power Supply Range ( $V_{CCI}$ )	3.0 to 3.6	3.0 to 3.6	V
5 V Power Supply Range ( $V_{CCI}$ )	4.75 to 5.25	4.75 to 5.25	V

## Typical SX-A Standby Current

Table 2-3 • Typical Standby Current for SX-A at 25°C with  $V_{CCA} = 2.5$  V

Product	$V_{CCI} = 2.5$ V	$V_{CCI} = 3.3$ V	$V_{CCI} = 5$ V
A54SX08A	0.8 mA	1.0 mA	2.9 mA
A54SX16A	0.8 mA	1.0 mA	2.9 mA
A54SX32A	0.9 mA	1.0 mA	3.0 mA
A54SX72A	3.6 mA	3.8 mA	4.5 mA

Table 2-4 • Supply Voltages

$V_{CCA}$	$V_{CCI}^*$	Maximum Input Tolerance	Maximum Output Drive
2.5 V	2.5 V	5.75 V	2.7 V
2.5 V	3.3 V	5.75 V	3.6 V
2.5 V	5 V	5.75 V	5.25 V

**Note:** \*3.3 V PCI is not 5 V tolerant due to the clamp diode, but instead is 3.3 V tolerant.

## Electrical Specifications

Table 2-5 • 3.3 V LVTTTL and 5 V TTL Electrical Specifications

Symbol	Parameter		Commercial		Industrial		Units
			Min.	Max.	Min.	Max.	
V <sub>OH</sub>	V <sub>CC1</sub> = Minimum V <sub>I</sub> = V <sub>IH</sub> or V <sub>IL</sub>	(I <sub>OH</sub> = -1 mA)	0.9 V <sub>CC1</sub>		0.9 V <sub>CC1</sub>		V
	V <sub>CC1</sub> = Minimum V <sub>I</sub> = V <sub>IH</sub> or V <sub>IL</sub>	(I <sub>OH</sub> = -8 mA)	2.4		2.4		V
V <sub>OL</sub>	V <sub>CC1</sub> = Minimum V <sub>I</sub> = V <sub>IH</sub> or V <sub>IL</sub>	(I <sub>OL</sub> = 1 mA)	0.4		0.4		V
	V <sub>CC1</sub> = Minimum V <sub>I</sub> = V <sub>IH</sub> or V <sub>IL</sub>	(I <sub>OL</sub> = 12 mA)	0.4		0.4		V
V <sub>IL</sub>	Input Low Voltage		0.8		0.8		V
V <sub>IH</sub>	Input High Voltage		2.0	5.75	2.0	5.75	V
I <sub>IL</sub> /I <sub>IH</sub>	Input Leakage Current, V <sub>IN</sub> = V <sub>CC1</sub> or GND		-10	10	-10	10	μA
I <sub>OZ</sub>	Tristate Output Leakage Current		-10	10	-10	10	μA
t <sub>R</sub> , t <sub>F</sub>	Input Transition Time t <sub>R</sub> , t <sub>F</sub>		10		10		ns
C <sub>IO</sub>	I/O Capacitance		10		10		pF
I <sub>CC</sub>	Standby Current		10		20		mA
IV Curve*	Can be derived from the IBIS model on the web.						

**Note:** \*The IBIS model can be found at <http://www.actel.com/download/ibis/default.aspx>.

Table 2-6 • 2.5 V LVCMOS2 Electrical Specifications

Symbol	Parameter		Commercial		Industrial		Units
			Min.	Max.	Min.	Max.	
V <sub>OH</sub>	V <sub>DD</sub> = MIN, V <sub>I</sub> = V <sub>IH</sub> or V <sub>IL</sub>	(I <sub>OH</sub> = -100 μA)	2.1		2.1		V
	V <sub>DD</sub> = MIN, V <sub>I</sub> = V <sub>IH</sub> or V <sub>IL</sub>	(I <sub>OH</sub> = -1 mA)	2.0		2.0		V
	V <sub>DD</sub> = MIN, V <sub>I</sub> = V <sub>IH</sub> or V <sub>IL</sub>	(I <sub>OH</sub> = -2 mA)	1.7		1.7		V
V <sub>OL</sub>	V <sub>DD</sub> = MIN, V <sub>I</sub> = V <sub>IH</sub> or V <sub>IL</sub>	(I <sub>OL</sub> = 100 μA)	0.2		0.2		V
	V <sub>DD</sub> = MIN, V <sub>I</sub> = V <sub>IH</sub> or V <sub>IL</sub>	(I <sub>OL</sub> = 1 mA)	0.4		0.4		V
	V <sub>DD</sub> = MIN, V <sub>I</sub> = V <sub>IH</sub> or V <sub>IL</sub>	(I <sub>OL</sub> = 2 mA)	0.7		0.7		V
V <sub>IL</sub>	Input Low Voltage, V <sub>OUT</sub> ≤ V <sub>VOL(max)</sub>		-0.3	0.7	-0.3	0.7	V
V <sub>IH</sub>	Input High Voltage, V <sub>OUT</sub> ≥ V <sub>VOH(min)</sub>		1.7	5.75	1.7	5.75	V
I <sub>IL</sub> /I <sub>IH</sub>	Input Leakage Current, V <sub>IN</sub> = V <sub>CC1</sub> or GND		-10	10	-10	10	μA
I <sub>OZ</sub>	Tristate Output Leakage Current, V <sub>OUT</sub> = V <sub>CC1</sub> or GND		-10	10	-10	10	μA
t <sub>R</sub> , t <sub>F</sub>	Input Transition Time t <sub>R</sub> , t <sub>F</sub>		10		10		ns
C <sub>IO</sub>	I/O Capacitance		10		10		pF
I <sub>CC</sub>	Standby Current		10		20		mA
IV Curve*	Can be derived from the IBIS model on the web.						

**Note:** \*The IBIS model can be found at <http://www.actel.com/download/ibis/default.aspx>.

## PCI Compliance for the SX-A Family

The SX-A family supports 3.3 V and 5 V PCI and is compliant with the PCI Local Bus Specification Rev. 2.1.

Table 2-7 • DC Specifications (5 V PCI Operation)

Symbol	Parameter	Condition	Min.	Max.	Units
V <sub>CCA</sub>	Supply Voltage for Array		2.25	2.75	V
V <sub>CCI</sub>	Supply Voltage for I/Os		4.75	5.25	V
V <sub>IH</sub>	Input High Voltage		2.0	5.75	V
V <sub>IL</sub>	Input Low Voltage		-0.5	0.8	V
I <sub>IH</sub>	Input High Leakage Current <sup>1</sup>	V <sub>IN</sub> = 2.7	-	70	μA
I <sub>IL</sub>	Input Low Leakage Current <sup>1</sup>	V <sub>IN</sub> = 0.5	-	-70	μA
V <sub>OH</sub>	Output High Voltage	I <sub>OUT</sub> = -2 mA	2.4	-	V
V <sub>OL</sub>	Output Low Voltage <sup>2</sup>	I <sub>OUT</sub> = 3 mA, 6 mA	-	0.55	V
C <sub>IN</sub>	Input Pin Capacitance <sup>3</sup>		-	10	pF
C <sub>CLK</sub>	CLK Pin Capacitance		5	12	pF

### Notes:

1. Input leakage currents include hi-Z output leakage for all bidirectional buffers with tristate outputs.
2. Signals without pull-up resistors must have 3 mA low output current. Signals requiring pull-up must have 6 mA; the latter includes FRAME#, IRDY#, TRDY#, DEVSEL#, STOP#, SERR#, PERR#, LOCK#, and, when used AD[63::32], C/BE[7::4]#, PAR64, REQ64#, and ACK64#.
3. Absolute maximum pin capacitance for a PCI input is 10 pF (except for CLK).

Table 2-8 • AC Specifications (5 V PCI Operation)

Symbol	Parameter	Condition	Min.	Max.	Units
$I_{OH(AC)}$	Switching Current High	$0 < V_{OUT} \leq 1.4$ <sup>1</sup>	-44	-	mA
		$1.4 \leq V_{OUT} < 2.4$ <sup>1, 2</sup>	$(-44 + (V_{OUT} - 1.4)/0.024)$	-	mA
		$3.1 < V_{OUT} < V_{CCI}$ <sup>1, 3</sup>	-	EQ 2-1 on page 2-5	-
	(Test Point)	$V_{OUT} = 3.1$ <sup>3</sup>	-	-142	mA
$I_{OL(AC)}$	Switching Current Low	$V_{OUT} \geq 2.2$ <sup>1</sup>	95	-	mA
		$2.2 > V_{OUT} > 0.55$ <sup>1</sup>	$(V_{OUT}/0.023)$	-	mA
		$0.71 > V_{OUT} > 0$ <sup>1, 3</sup>	-	EQ 2-2 on page 2-5	-
	(Test Point)	$V_{OUT} = 0.71$ <sup>3</sup>	-	206	mA
$I_{CL}$	Low Clamp Current	$-5 < V_{IN} \leq -1$	$-25 + (V_{IN} + 1)/0.015$	-	mA
$slew_R$	Output Rise Slew Rate	0.4 V to 2.4 V load <sup>4</sup>	1	5	V/ns
$slew_F$	Output Fall Slew Rate	2.4 V to 0.4 V load <sup>4</sup>	1	5	V/ns

**Notes:**

1. Refer to the V/I curves in Figure 2-1 on page 2-5. Switching current characteristics for REQ# and GNT# are permitted to be one half of that specified here; i.e., half size output drivers may be used on these signals. This specification does not apply to CLK and RST#, which are system outputs. "Switching Current High" specifications are not relevant to SERR#, INTA#, INTB#, INTC#, and INTD#, which are open drain outputs.
2. Note that this segment of the minimum current curve is drawn from the AC drive point directly to the DC drive point rather than toward the voltage rail (as is done in the pull-down curve). This difference is intended to allow for an optional N-channel pull-up.
3. Maximum current requirements must be met as drivers pull beyond the last step voltage. Equations defining these maximums (A and B) are provided with the respective diagrams in Figure 2-1 on page 2-5. The equation defined maximum should be met by design. In order to facilitate component testing, a maximum current test point is defined for each side of the output driver.
4. This parameter is to be interpreted as the cumulative edge rate across the specified range, rather than the instantaneous rate at any point within the transition range. The specified load (diagram below) is optional; i.e., the designer may elect to meet this parameter with an unloaded output per revision 2.0 of the PCI Local Bus Specification. However, adherence to both maximum and minimum parameters is now required (the maximum is no longer simply a guideline). Since adherence to the maximum slew rate was not required prior to revision 2.1 of the specification, there may be components in the market for some time that have faster edge rates; therefore, motherboard designers must bear in mind that rise and fall times faster than this specification could occur and should ensure that signal integrity modeling accounts for this. Rise slew rate does not apply to open drain outputs.



Figure 2-1 shows the 5 V PCI V/I curve and the minimum and maximum PCI drive characteristics of the SX-A family.



Figure 2-1 • 5 V PCI V/I Curve for SX-A Family

$$I_{OH} = 11.9 * (V_{OUT} - 5.25) * (V_{OUT} + 2.45)$$

for  $V_{CCI} > V_{OUT} > 3.1V$

EQ 2-1

$$I_{OL} = 78.5 * V_{OUT} * (4.4 - V_{OUT})$$

for  $0V < V_{OUT} < 0.71V$

EQ 2-2

Table 2-9 • DC Specifications (3.3 V PCI Operation)

Symbol	Parameter	Condition	Min.	Max.	Units
V <sub>CCA</sub>	Supply Voltage for Array		2.25	2.75	V
V <sub>CCI</sub>	Supply Voltage for I/Os		3.0	3.6	V
V <sub>IH</sub>	Input High Voltage		0.5V <sub>CCI</sub>	V <sub>CCI</sub> + 0.5	V
V <sub>IL</sub>	Input Low Voltage		-0.5	0.3V <sub>CCI</sub>	V
I <sub>IPU</sub>	Input Pull-up Voltage <sup>1</sup>		0.7V <sub>CCI</sub>	-	V
I <sub>IL</sub>	Input Leakage Current <sup>2</sup>	0 < V <sub>IN</sub> < V <sub>CCI</sub>	-10	+10	μA
V <sub>OH</sub>	Output High Voltage	I <sub>OUT</sub> = -500 μA	0.9V <sub>CCI</sub>	-	V
V <sub>OL</sub>	Output Low Voltage	I <sub>OUT</sub> = 1,500 μA	-	0.1V <sub>CCI</sub>	V
C <sub>IN</sub>	Input Pin Capacitance <sup>3</sup>		-	10	pF
C <sub>CLK</sub>	CLK Pin Capacitance		5	12	pF

**Notes:**

1. This specification should be guaranteed by design. It is the minimum voltage to which pull-up resistors are calculated to pull a floated network. Designers should ensure that the input buffer is conducting minimum current at this input voltage in applications sensitive to static power utilization.
2. Input leakage currents include hi-Z output leakage for all bidirectional buffers with tristate outputs.
3. Absolute maximum pin capacitance for a PCI input is 10 pF (except for CLK).

Table 2-10 • AC Specifications (3.3 V PCI Operation)

Symbol	Parameter	Condition	Min.	Max.	Units
$I_{OH(AC)}$	Switching Current High	$0 < V_{OUT} \leq 0.3V_{CCI}^1$	$-12V_{CCI}$	–	mA
		$0.3V_{CCI} \leq V_{OUT} < 0.9V_{CCI}^1$	$(-17.1(V_{CCI} - V_{OUT}))$	–	mA
		$0.7V_{CCI} < V_{OUT} < V_{CCI}^{1,2}$	–	EQ 2-3 on page 2-7	–
	(Test Point)	$V_{OUT} = 0.7V_{CC}^2$	–	$-32V_{CCI}$	mA
$I_{OL(AC)}$	Switching Current Low	$V_{CCI} > V_{OUT} \geq 0.6V_{CCI}^1$	$16V_{CCI}$	–	mA
		$0.6V_{CCI} > V_{OUT} > 0.1V_{CCI}^1$	$(26.7V_{OUT})$	–	mA
		$0.18V_{CCI} > V_{OUT} > 0^{1,2}$	–	EQ 2-4 on page 2-7	–
	(Test Point)	$V_{OUT} = 0.18V_{CC}^2$	–	$38V_{CCI}$	mA
$I_{CL}$	Low Clamp Current	$-3 < V_{IN} \leq -1$	$-25 + (V_{IN} + 1)/0.015$	–	mA
$I_{CH}$	High Clamp Current	$V_{CCI} + 4 > V_{IN} \geq V_{CCI} + 1$	$25 + (V_{IN} - V_{CCI} - 1)/0.015$	–	mA
$slew_R$	Output Rise Slew Rate	$0.2V_{CCI} - 0.6V_{CCI}$ load <sup>3</sup>	1	4	V/ns
$slew_F$	Output Fall Slew Rate	$0.6V_{CCI} - 0.2V_{CCI}$ load <sup>3</sup>	1	4	V/ns

**Notes:**

1. Refer to the V/I curves in Figure 2-2 on page 2-7. Switching current characteristics for REQ# and GNT# are permitted to be one half of that specified here; i.e., half size output drivers may be used on these signals. This specification does not apply to CLK and RST#, which are system outputs. "Switching Current High" specifications are not relevant to SERR#, INTA#, INTB#, INTC#, and INTD#, which are open drain outputs.
2. Maximum current requirements must be met as drivers pull beyond the last step voltage. Equations defining these maximums (C and D) are provided with the respective diagrams in Figure 2-2 on page 2-7. The equation defined maximum should be met by design. In order to facilitate component testing, a maximum current test point is defined for each side of the output driver.
3. This parameter is to be interpreted as the cumulative edge rate across the specified range, rather than the instantaneous rate at any point within the transition range. The specified load (diagram below) is optional; i.e., the designer may elect to meet this parameter with an unloaded output per the latest revision of the PCI Local Bus Specification. However, adherence to both maximum and minimum parameters is required (the maximum is no longer simply a guideline). Rise slew rate does not apply to open drain outputs.



Figure 2-2 shows the 3.3 V PCI V/I curve and the minimum and maximum PCI drive characteristics of the SX-A family.

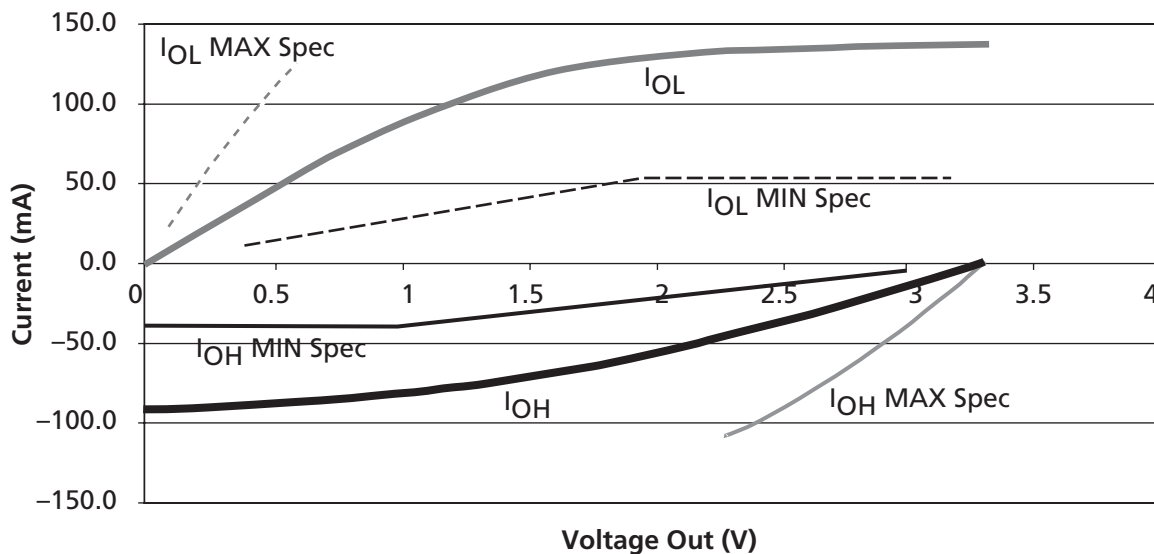

Figure 2-2 • 3.3 V PCI V/I Curve for SX-A Family

$$I_{OH} = (98.0/V_{CC1}) * (V_{OUT} - V_{CC1}) * (V_{OUT} + 0.4V_{CC1})$$

for  $0.7 V_{CC1} < V_{OUT} < V_{CC1}$

EQ 2-3

$$I_{OL} = (256/V_{CC1}) * V_{OUT} * (V_{CC1} - V_{OUT})$$

for  $0V < V_{OUT} < 0.18 V_{CC1}$

EQ 2-4

## Power Dissipation

A critical element of system reliability is the ability of electronic devices to safely dissipate the heat generated during operation. The thermal characteristics of a circuit depend on the device and package used, the operating temperature, the operating current, and the system's ability to dissipate heat.

A complete power evaluation should be performed early in the design process to help identify potential heat-related problems in the system and to prevent the system from exceeding the device's maximum allowed junction temperature.

The actual power dissipated by most applications is significantly lower than the power the package can dissipate. However, a thermal analysis should be performed for all projects. To perform a power evaluation, follow these steps:

1. Estimate the power consumption of the application.
2. Calculate the maximum power allowed for the device and package.
3. Compare the estimated power and maximum power values.

### Estimating Power Dissipation

The total power dissipation for the SX-A family is the sum of the DC power dissipation and the AC power dissipation:

$$P_{\text{Total}} = P_{\text{DC}} + P_{\text{AC}}$$

EQ 2-5

### DC Power Dissipation

The power due to standby current is typically a small component of the overall power. An estimation of DC power dissipation under typical conditions is given by:

$$P_{\text{DC}} = I_{\text{standby}} * V_{\text{CCA}}$$

EQ 2-6

Note: For other combinations of temperature and voltage settings, refer to the [eX, SX-A and RT54SX-S Power Calculator](#).

### AC Power Dissipation

The power dissipation of the SX-A family is usually dominated by the dynamic power dissipation. Dynamic power dissipation is a function of frequency, equivalent capacitance, and power supply voltage. The AC power dissipation is defined as follows:

$$P_{\text{AC}} = P_{\text{C-cells}} + P_{\text{R-cells}} + P_{\text{CLKA}} + P_{\text{CLKB}} + P_{\text{HCLK}} + P_{\text{Output Buffer}} + P_{\text{Input Buffer}}$$

EQ 2-7

or:

$$P_{\text{AC}} = V_{\text{CCA}}^2 * [(m * C_{\text{EQCM}} * f_m)_{\text{C-cells}} + (m * C_{\text{EQSM}} * f_m)_{\text{R-cells}} + (n * C_{\text{EQI}} * f_n)_{\text{Input Buffer}} + (p * (C_{\text{EQO}} + C_L) * f_p)_{\text{Output Buffer}} + (0.5 * (q_1 * C_{\text{EQCR}} * f_{q1}) + (r_1 * f_{q1}))_{\text{CLKA}} + (0.5 * (q_2 * C_{\text{EQCR}} * f_{q2}) + (r_2 * f_{q2}))_{\text{CLKB}} + (0.5 * (s_1 * C_{\text{EQHV}} * f_{s1}) + (C_{\text{EQHF}} * f_{s1}))_{\text{HCLK}]$$

EQ 2-8

**Where:**

- $C_{EQCM}$  = Equivalent capacitance of combinatorial modules (C-cells) in pF
- $C_{EQSM}$  = Equivalent capacitance of sequential modules (R-Cells) in pF
- $C_{EQI}$  = Equivalent capacitance of input buffers in pF
- $C_{EQO}$  = Equivalent capacitance of output buffers in pF
- $C_{EQCR}$  = Equivalent capacitance of CLKA/B in pF
- $C_{EQHV}$  = Variable capacitance of HCLK in pF
- $C_{EQHF}$  = Fixed capacitance of HCLK in pF
- $C_L$  = Output lead capacitance in pF
- $f_m$  = Average logic module switching rate in MHz
- $f_n$  = Average input buffer switching rate in MHz
- $f_p$  = Average output buffer switching rate in MHz
- $f_{q1}$  = Average CLKA rate in MHz
- $f_{q2}$  = Average CLKB rate in MHz
- $f_{s1}$  = Average HCLK rate in MHz
- $m$  = Number of logic modules switching at  $f_m$
- $n$  = Number of input buffers switching at  $f_n$
- $p$  = Number of output buffers switching at  $f_p$
- $q_1$  = Number of clock loads on CLKA
- $q_2$  = Number of clock loads on CLKB
- $r_1$  = Fixed capacitance due to CLKA
- $r_2$  = Fixed capacitance due to CLKB
- $s_1$  = Number of clock loads on HCLK
- $x$  = Number of I/Os at logic low
- $y$  = Number of I/Os at logic high

**Table 2-11 • CEQ Values for SX-A Devices**

	<b>A54SX08A</b>	<b>A54SX16A</b>	<b>A54SX32A</b>	<b>A54SX72A</b>
Combinatorial modules ( $C_{EQCM}$ )	1.70 pF	2.00 pF	2.00 pF	1.80 pF
Sequential modules ( $C_{EQSM}$ )	1.50 pF	1.50 pF	1.30 pF	1.50 pF
Input buffers ( $C_{EQI}$ )	1.30 pF	1.30 pF	1.30 pF	1.30 pF
Output buffers ( $C_{EQO}$ )	7.40 pF	7.40 pF	7.40 pF	7.40 pF
Routed array clocks ( $C_{EQCR}$ )	1.05 pF	1.05 pF	1.05 pF	1.05 pF
Dedicated array clocks – variable ( $C_{EQHV}$ )	0.85 pF	0.85 pF	0.85 pF	0.85 pF
Dedicated array clocks – fixed ( $C_{EQHF}$ )	30.00 pF	55.00 pF	110.00 pF	240.00 pF
Routed array clock A ( $r_1$ )	35.00 pF	50.00 pF	90.00 pF	310.00 pF

## Guidelines for Estimating Power

The following guidelines are meant to represent worst-case scenarios; they can be generally used to predict the upper limits of power dissipation:

Logic Modules (m) = 20% of modules

Inputs Switching (n) = Number inputs/4

Outputs Switching (p) = Number of outputs/4

CLKA Loads (q1) = 20% of R-cells

CLKB Loads (q2) = 20% of R-cells

Load Capacitance (CL) = 35 pF

Average Logic Module Switching Rate (fm) = f/10

Average Input Switching Rate (fn) = f/5

Average Output Switching Rate (fp) = f/10

Average CLKA Rate (fq1) = f/2

Average CLKB Rate (fq2) = f/2

Average HCLK Rate (fs1) = f

HCLK loads (s1) = 20% of R-cells

To assist customers in estimating the power dissipations of their designs, Actel has published the [eX, SX-A and RT54SX-S Power Calculator](#) worksheet.

## Thermal Characteristics

### Introduction

The temperature variable in Actel Designer software refers to the junction temperature, not the ambient, case, or board temperatures. This is an important distinction because dynamic and static power consumption will cause the chip's junction to be higher than the ambient, case, or board temperatures. EQ 2-9 and EQ 2-10 give the relationship between thermal resistance, temperature gradient and power.

$$\theta_{JA} = \frac{T_J - T_A}{P}$$

EQ 2-9

$$\theta_{JA} = \frac{T_C - T_A}{P}$$

EQ 2-10

Where:

- $\theta_{JA}$  = Junction-to-air thermal resistance
- $\theta_{JC}$  = Junction-to-case thermal resistance
- $T_J$  = Junction temperature
- $T_A$  = Ambient temperature
- $T_C$  = Ambient temperature
- $P$  = total power dissipated by the device

Table 2-12 • Package Thermal Characteristics

Package Type	Pin Count	$\theta_{JC}$	$\theta_{JA}$			Units
			Still Air	1.0 m/s 200 ft./min.	2.5 m/s 500 ft./min.	
Thin Quad Flat Pack (TQFP)	100	14	33.5	27.4	25	°C/W
Thin Quad Flat Pack (TQFP)	144	11	33.5	28	25.7	°C/W
Thin Quad Flat Pack (TQFP)	176	11	24.7	19.9	18	°C/W
Plastic Quad Flat Pack (PQFP) <sup>1</sup>	208	8	26.1	22.5	20.8	°C/W
Plastic Quad Flat Pack (PQFP) with Heat Spreader <sup>2</sup>	208	3.8	16.2	13.3	11.9	°C/W
Plastic Ball Grid Array (PBGA)	329	3	17.1	13.8	12.8	°C/W
Fine Pitch Ball Grid Array (FBGA)	144	3.8	26.9	22.9	21.5	°C/W
Fine Pitch Ball Grid Array (FBGA)	256	3.8	26.6	22.8	21.5	°C/W
Fine Pitch Ball Grid Array (FBGA)	484	3.2	18	14.7	13.6	°C/W

**Notes:**

- The A54SX08A PQ208 has no heat spreader.
- The SX-A PQ208 package has a heat spreader for A54SX16A, A54SX32A, and A54SX72A.

## Theta-JA

Junction-to-ambient thermal resistance ( $\theta_{JA}$ ) is determined under standard conditions specified by JESD-51 series but has little relevance in actual performance of the product in real application. It should be employed with caution but is useful for comparing the thermal performance of one package to another.

A sample calculation to estimate the absolute maximum power dissipation allowed (worst case) for a 329-pin PBGA package at still air is as follows. i.e.:

$$\theta_{JA} = 17.1^{\circ}\text{C/W} \text{ is taken from Table 2-12 on page 2-11}$$

$$T_A = 125^{\circ}\text{C} \text{ is the maximum limit of ambient (from the datasheet)}$$

$$\text{Max. Allowed Power} = \frac{\text{Max Junction Temp} - \text{Max. Ambient Temp}}{\theta_{JA}} = \frac{150^{\circ}\text{C} - 125^{\circ}\text{C}}{17.1^{\circ}\text{C/W}} = 1.46 \text{ W}$$

EQ 2-11

The device's power consumption must be lower than the calculated maximum power dissipation by the package.

The power consumption of a device can be calculated using the Actel power calculator. If the power consumption is higher than the device's maximum allowable power dissipation, then a heat sink can be attached on top of the case or the airflow inside the system must be increased.

## Theta-JC

Junction-to-case thermal resistance ( $\theta_{JC}$ ) measures the ability of a device to dissipate heat from the surface of the chip to the top or bottom surface of the package. It is applicable for packages used with external heat sinks and only applies to situations where all or nearly all of the heat is dissipated through the surface in consideration. If the power consumption is higher than the calculated maximum power dissipation of the package, then a heat sink is required.

## Calculation for Heat Sink

For example, in a design implemented in a FG484 package, the power consumption value using the power calculator is 3.00 W. The user-dependent data  $T_J$  and  $T_A$  are given as follows:

$$T_J = 110^{\circ}\text{C}$$

$$T_A = 70^{\circ}\text{C}$$

From the datasheet:

$$\theta_{JA} = 18.0^{\circ}\text{C/W}$$

$$\theta_{JC} = 3.2^{\circ}\text{C/W}$$

$$P = \frac{\text{Max Junction Temp} - \text{Max. Ambient Temp}}{\theta_{JA}} = \frac{110^{\circ}\text{C} - 70^{\circ}\text{C}}{18.0^{\circ}\text{C/W}} = 2.22 \text{ W}$$

EQ 2-12

The 2.22 W power is less than then required 3.00 W; therefore, the design requires a heat sink or the airflow where the device is mounted should be increased. The design's junction-to-air thermal resistance requirement can be estimated by:

$$\theta_{JA} = \frac{\text{Max Junction Temp} - \text{Max. Ambient Temp}}{P} = \frac{110^{\circ}\text{C} - 70^{\circ}\text{C}}{3.00 \text{ W}} = 13.33^{\circ}\text{C/W}$$

EQ 2-13

To determine the heat sink's thermal performance, use the following equation:

$$\theta_{JA(TOTAL)} = \theta_{JC} + \theta_{CS} + \theta_{SA}$$

EQ 2-14

where:

$$\theta_{CS} = 0.37^{\circ}C/W$$

= thermal resistance of the interface material between the case and the heat sink, usually provided by the thermal interface manufacturer

$$\theta_{SA} = \text{thermal resistance of the heat sink in } ^{\circ}C/W$$

$$\theta_{SA} = \theta_{JA(TOTAL)} - \theta_{JC} - \theta_{CS}$$

EQ 2-15

$$\theta_{SA} = 13.33^{\circ}C/W - 3.20^{\circ}C/W - 0.37^{\circ}C/W$$

$$\theta_{SA} = 9.76^{\circ}C/W$$

A heat sink with a thermal resistance of  $9.76^{\circ}C/W$  or better should be used. Thermal resistance of heat sinks is a function of airflow. The heat sink performance can be significantly improved with the presence of airflow.

Carefully estimating thermal resistance is important in the long-term reliability of an Actel FPGA. Design engineers should always correlate the power consumption of the device with the maximum allowable power dissipation of the package selected for that device, using the provided thermal resistance data.

Note: The values may vary depending on the application.

# SX-A Timing Model



**Note:** \*Values shown for A54SX72A, -2, worst-case commercial conditions at 5 V PCI with standard place-and-route.

Figure 2-3 • SX-A Timing Model

## Sample Path Calculations

### Hardwired Clock

External Setup =  $(t_{IN\text{YH}} + t_{RD1} + t_{SUD}) - t_{HCKH}$   
 =  $0.6 + 0.3 + 0.8 - 1.8 = -0.1 \text{ ns}$

Clock-to-Out (Pad-to-Pad) =  $t_{HCKH} + t_{RCO} + t_{RD1} + t_{DHL}$   
 =  $1.8 + 0.8 + 0.3 + 3.9 = 6.8 \text{ ns}$

### Routed Clock

External Setup =  $(t_{IN\text{YH}} + t_{RD1} + t_{SUD}) - t_{RCKH}$   
 =  $0.6 + 0.3 + 0.8 - 3.0 = -1.3 \text{ ns}$

Clock-to-Out (Pad-to-Pad) =  $t_{RCKH} + t_{RCO} + t_{RD1} + t_{DHL}$   
 =  $3.0 + 0.8 + 0.3 + 3.9 = 8.0 \text{ ns}$

## Output Buffer Delays

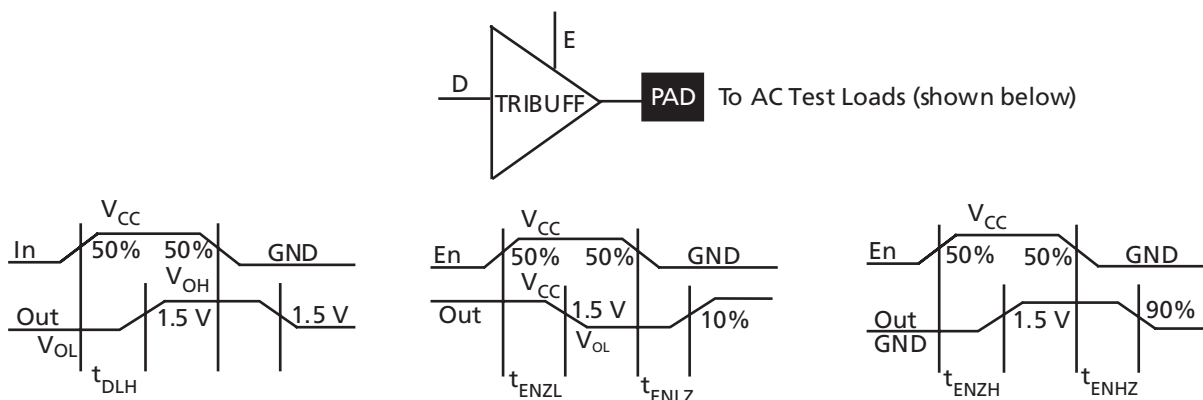

Figure 2-4 • Output Buffer Delays

## AC Test Loads



Figure 2-5 • AC Test Loads

## Input Buffer Delays



Figure 2-6 • Input Buffer Delays

## C-Cell Delays



Figure 2-7 • C-Cell Delays

## Cell Timing Characteristics



Figure 2-8 • Flip-Flops

## Timing Characteristics

Timing characteristics for SX-A devices fall into three categories: family-dependent, device-dependent, and design-dependent. The input and output buffer characteristics are common to all SX-A family members. Internal routing delays are device-dependent. Design dependency means actual delays are not determined until after placement and routing of the user's design are complete. The timing characteristics listed in this datasheet represent sample timing numbers of the SX-A devices. Design-specific delay values may be determined by using Timer or performing simulation after successful place-and-route with the Designer software.

### Critical Nets and Typical Nets

Propagation delays are expressed only for typical nets, which are used for initial design performance evaluation. Critical net delays can then be applied to the most timing-critical paths. Critical nets are determined by net property assignment prior to placement and routing. Up to 6 percent of the nets in a design may be designated as critical, while 90 percent of the nets in a design are typical.

### Long Tracks

Some nets in the design use long tracks. Long tracks are special routing resources that span multiple rows, columns, or modules. Long tracks employ three to five antifuse connections. This increases capacitance and resistance, resulting in longer net delays for macros connected to long tracks. Typically, up to 6 percent of nets in a fully utilized device require long tracks. Long tracks contribute approximately 4 ns to 8.4 ns delay. This additional delay is represented statistically in higher fanout routing delays.

### Timing Derating

SX-A devices are manufactured with a CMOS process. Therefore, device performance varies according to temperature, voltage, and process changes. Minimum timing parameters reflect maximum operating voltage, minimum operating temperature, and best-case processing. Maximum timing parameters reflect minimum operating voltage, maximum operating temperature, and worst-case processing.

## Temperature and Voltage Derating Factors

Table 2-13 • Temperature and Voltage Derating Factors  
(Normalized to Worst-Case Commercial,  $T_J = 70^\circ\text{C}$ ,  $V_{CCA} = 2.25\text{ V}$ )

$V_{CCA}$	Junction Temperature ( $T_J$ )						
	$-55^\circ\text{C}$	$-40^\circ\text{C}$	$0^\circ\text{C}$	$25^\circ\text{C}$	$70^\circ\text{C}$	$85^\circ\text{C}$	$125^\circ\text{C}$
2.250 V	0.79	0.80	0.87	0.89	1.00	1.04	1.14
2.500 V	0.74	0.75	0.82	0.83	0.94	0.97	1.07
2.750 V	0.68	0.69	0.75	0.77	0.87	0.90	0.99

## Timing Characteristics

Table 2-14 • A54SX08A Timing Characteristics  
(Worst-Case Commercial Conditions,  $V_{CCA} = 2.25\text{ V}$ ,  $V_{CCI} = 3.0\text{ V}$ ,  $T_J = 70^\circ\text{C}$ )

Parameter	Description	-2 Speed		-1 Speed		Std. Speed		-F Speed		Units
		Min.	Max.	Min.	Max.	Min.	Max.	Min.	Max.	
<b>C-Cell Propagation Delays<sup>1</sup></b>										
$t_{PD}$	Internal Array Module		0.9		1.1		1.2		1.7	ns
<b>Predicted Routing Delays<sup>2</sup></b>										
$t_{DC}$	FO = 1 Routing Delay, Direct Connect		0.1		0.1		0.1		0.1	ns
$t_{FC}$	FO = 1 Routing Delay, Fast Connect		0.3		0.3		0.4		0.6	ns
$t_{RD1}$	FO = 1 Routing Delay		0.3		0.4		0.5		0.6	ns
$t_{RD2}$	FO = 2 Routing Delay		0.5		0.5		0.6		0.8	ns
$t_{RD3}$	FO = 3 Routing Delay		0.6		0.7		0.8		1.1	ns
$t_{RD4}$	FO = 4 Routing Delay		0.8		0.9		1		1.4	ns
$t_{RD8}$	FO = 8 Routing Delay		1.4		1.5		1.8		2.5	ns
$t_{RD12}$	FO = 12 Routing Delay		2		2.2		2.6		3.6	ns
<b>R-Cell Timing</b>										
$t_{RCO}$	Sequential Clock-to-Q		0.7		0.8		0.9		1.3	ns
$t_{CLR}$	Asynchronous Clear-to-Q		0.6		0.6		0.8		1.0	ns
$t_{PRESET}$	Asynchronous Preset-to-Q		0.7		0.7		0.9		1.2	ns
$t_{SUD}$	Flip-Flop Data Input Set-Up	0.7		0.8		0.9		1.2		ns
$t_{HD}$	Flip-Flop Data Input Hold	0.0		0.0		0.0		0.0		ns
$t_{WASYN}$	Asynchronous Pulse Width	1.4		1.5		1.8		2.5		ns
$t_{RECA SYN}$	Asynchronous Recovery Time	0.4		0.4		0.5		0.7		ns
$t_{HASYN}$	Asynchronous Hold Time	0.3		0.3		0.4		0.6		ns
$t_{MPW}$	Clock Pulse Width	1.6		1.8		2.1		2.9		ns
<b>Input Module Propagation Delays</b>										
$t_{INYH}$	Input Data Pad to Y High 2.5 V LVCMOS		0.8		0.9		1.0		1.4	ns
$t_{INYL}$	Input Data Pad to Y Low 2.5 V LVCMOS		1.0		1.2		1.4		1.9	ns
$t_{INYH}$	Input Data Pad to Y High 3.3 V PCI		0.6		0.6		0.7		1.0	ns
$t_{INYL}$	Input Data Pad to Y Low 3.3 V PCI		0.7		0.8		0.9		1.3	ns
$t_{INYH}$	Input Data Pad to Y High 3.3 V LVTTTL		0.7		0.7		0.9		1.2	ns
$t_{INYL}$	Input Data Pad to Y Low 3.3 V LVTTTL		1.0		1.1		1.3		1.8	ns

**Notes:**

- For dual-module macros, use  $t_{PD} + t_{RD1} + t_{PDn}$ ,  $t_{RCO} + t_{RD1} + t_{PDn}$ , or  $t_{PD1} + t_{RD1} + t_{SUD}$ , whichever is appropriate.
- Routing delays are for typical designs across worst-case operating conditions. These parameters should be used for estimating device performance. Post-route timing analysis or simulation is required to determine actual performance.

Table 2-14 • A54SX08A Timing Characteristics (Continued)  
 (Worst-Case Commercial Conditions,  $V_{CCA} = 2.25\text{ V}$ ,  $V_{CCI} = 3.0\text{ V}$ ,  $T_J = 70^\circ\text{C}$ )

Parameter	Description	-2 Speed		-1 Speed		Std. Speed		-F Speed		Units
		Min.	Max.	Min.	Max.	Min.	Max.	Min.	Max.	
$t_{INYH}$	Input Data Pad to Y High 5 V PCI		0.5		0.6		0.7		0.9	ns
$t_{INYL}$	Input Data Pad to Y Low 5 V PCI		0.8		0.9		1.1		1.5	ns
$t_{INYH}$	Input Data Pad to Y High 5 V TTL		0.5		0.6		0.7		0.9	ns
$t_{INYL}$	Input Data Pad to Y Low 5 V TTL		0.8		0.9		1.1		1.5	ns
<b>Input Module Predicted Routing Delays<sup>2</sup></b>										
$t_{IRD1}$	FO = 1 Routing Delay		0.3		0.3		0.4		0.6	ns
$t_{IRD2}$	FO = 2 Routing Delay		0.5		0.5		0.6		0.8	ns
$t_{IRD3}$	FO = 3 Routing Delay		0.6		0.7		0.8		1.1	ns
$t_{IRD4}$	FO = 4 Routing Delay		0.8		0.9		1		1.4	ns
$t_{IRD8}$	FO = 8 Routing Delay		1.4		1.5		1.8		2.5	ns
$t_{IRD12}$	FO = 12 Routing Delay		2		2.2		2.6		3.6	ns

**Notes:**

1. For dual-module macros, use  $t_{PD} + t_{RD1} + t_{PDn}$ ,  $t_{RCO} + t_{RD1} + t_{PDn}$ , or  $t_{PD1} + t_{RD1} + t_{SUD}$ , whichever is appropriate.
2. Routing delays are for typical designs across worst-case operating conditions. These parameters should be used for estimating device performance. Post-route timing analysis or simulation is required to determine actual performance.

Table 2-15 • A54SX08A Timing Characteristics  
 (Worst-Case Commercial Conditions  $V_{CCA} = 2.25\text{ V}$ ,  $V_{CCI} = 2.25\text{ V}$ ,  $T_J = 70^\circ\text{C}$ )

Parameter	Description	-2 Speed		-1 Speed		Std. Speed		-F Speed		Units
		Min.	Max.	Min.	Max.	Min.	Max.	Min.	Max.	
<b>Dedicated (Hardwired) Array Clock Networks</b>										
$t_{HCKH}$	Input Low to High (Pad to R-cell Input)		1.4		1.6		1.8		2.6	ns
$t_{HCKL}$	Input High to Low (Pad to R-cell Input)		1.3		1.5		1.7		2.4	ns
$t_{HPWH}$	Minimum Pulse Width High	1.6		1.8		2.1		2.9		ns
$t_{HPWL}$	Minimum Pulse Width Low	1.6		1.8		2.1		2.9		ns
$t_{HCKSW}$	Maximum Skew		0.4		0.4		0.5		0.7	ns
$t_{HP}$	Minimum Period	3.2		3.6		4.2		5.8		ns
$f_{HMAX}$	Maximum Frequency		313		278		238		172	MHz
<b>Routed Array Clock Networks</b>										
$t_{RCKH}$	Input Low to High (Light Load) (Pad to R-cell Input)		1.0		1.1		1.3		1.8	ns
$t_{RCKL}$	Input High to Low (Light Load) (Pad to R-cell Input)		1.1		1.2		1.4		2.0	ns
$t_{RCKH}$	Input Low to High (50% Load) (Pad to R-cell Input)		1.0		1.1		1.3		1.8	ns
$t_{RCKL}$	Input High to Low (50% Load) (Pad to R-cell Input)		1.1		1.2		1.4		2.0	ns
$t_{RCKH}$	Input Low to High (100% Load) (Pad to R-cell Input)		1.1		1.2		1.4		2.0	ns
$t_{RCKL}$	Input High to Low (100% Load) (Pad to R-cell Input)		1.3		1.5		1.7		2.4	ns
$t_{RPWH}$	Minimum Pulse Width High	1.6		1.8		2.1		2.9		ns
$t_{RPWL}$	Minimum Pulse Width Low	1.6		1.8		2.1		2.9		ns
$t_{RCKSW}$	Maximum Skew (Light Load)		0.7		0.8		0.9		1.3	ns
$t_{RCKSW}$	Maximum Skew (50% Load)		0.7		0.8		0.9		1.3	ns
$t_{RCKSW}$	Maximum Skew (100% Load)		0.9		1.0		1.2		1.7	ns

Table 2-16 • A54SX08A Timing Characteristics  
 (Worst-Case Commercial Conditions  $V_{CCA} = 2.25\text{ V}$ ,  $V_{CCI} = 3.0\text{ V}$ ,  $T_J = 70^\circ\text{C}$ )

Parameter	Description	-2 Speed		-1 Speed		Std. Speed		-F Speed		Units
		Min.	Max.	Min.	Max.	Min.	Max.	Min.	Max.	
<b>Dedicated (Hardwired) Array Clock Networks</b>										
$t_{HCKH}$	Input Low to High (Pad to R-cell Input)		1.3		1.5		1.7		2.6	ns
$t_{HCKL}$	Input High to Low (Pad to R-cell Input)		1.1		1.3		1.5		2.2	ns
$t_{HPWH}$	Minimum Pulse Width High	1.6		1.8		2.1		2.9		ns
$t_{HPWL}$	Minimum Pulse Width Low	1.6		1.8		2.1		2.9		ns
$t_{HCKSW}$	Maximum Skew		0.4		0.5		0.5		0.8	ns
$t_{HP}$	Minimum Period	3.2		3.6		4.2		5.8		ns
$f_{HMAX}$	Maximum Frequency		313		278		238		172	MHz
<b>Routed Array Clock Networks</b>										
$t_{RCKH}$	Input Low to High (Light Load) (Pad to R-cell Input)		0.8		0.9		1.1		1.5	ns
$t_{RCKL}$	Input High to Low (Light Load) (Pad to R-cell Input)		1.1		1.2		1.4		2	ns
$t_{RCKH}$	Input Low to High (50% Load) (Pad to R-cell Input)		0.8		0.9		1.1		1.5	ns
$t_{RCKL}$	Input High to Low (50% Load) (Pad to R-cell Input)		1.1		1.2		1.4		2	ns
$t_{RCKH}$	Input Low to High (100% Load) (Pad to R-cell Input)		1.1		1.2		1.4		1.9	ns
$t_{RCKL}$	Input High to Low (100% Load) (Pad to R-cell Input)		1.2		1.3		1.6		2.2	ns
$t_{RPWH}$	Minimum Pulse Width High	1.6		1.8		2.1		2.9		ns
$t_{RPWL}$	Minimum Pulse Width Low	1.6		1.8		2.1		2.9		ns
$t_{RCKSW}$	Maximum Skew (Light Load)		0.7		0.8		0.9		1.3	ns
$t_{RCKSW}$	Maximum Skew (50% Load)		0.7		0.8		0.9		1.3	ns
$t_{RCKSW}$	Maximum Skew (100% Load)		0.8		0.9		1.1		1.5	ns

Table 2-17 • A54SX08A Timing Characteristics  
 (Worst-Case Commercial Conditions  $V_{CCA} = 2.25\text{ V}$ ,  $V_{CCI} = 4.75\text{ V}$ ,  $T_J = 70^\circ\text{C}$ )

Parameter	Description	-2 Speed		-1 Speed		Std. Speed		-F Speed		Units
		Min.	Max.	Min.	Max.	Min.	Max.	Min.	Max.	
<b>Dedicated (Hardwired) Array Clock Networks</b>										
$t_{HCKH}$	Input Low to High (Pad to R-cell Input)		1.2		1.3		1.5		2.3	ns
$t_{HCKL}$	Input High to Low (Pad to R-cell Input)		1.0		1.2		1.4		2.0	ns
$t_{HPWH}$	Minimum Pulse Width High	1.6		1.8		2.1		2.9		ns
$t_{HPWL}$	Minimum Pulse Width Low	1.6		1.8		2.1		2.9		ns
$t_{HCKSW}$	Maximum Skew		0.4		0.4		0.5		0.8	ns
$t_{HP}$	Minimum Period	3.2		3.6		4.2		5.8		ns
$f_{HMAX}$	Maximum Frequency		313		278		238		172	MHz
<b>Routed Array Clock Networks</b>										
$t_{RCKH}$	Input Low to High (Light Load) (Pad to R-cell Input)		0.9		1.0		1.2		1.7	ns
$t_{RCKL}$	Input High to Low (Light Load) (Pad to R-cell Input)		1.5		1.7		2.0		2.7	ns
$t_{RCKH}$	Input Low to High (50% Load) (Pad to R-cell Input)		0.9		1.0		1.2		1.7	ns
$t_{RCKL}$	Input High to Low (50% Load) (Pad to R-cell Input)		1.5		1.7		2.0		2.7	ns
$t_{RCKH}$	Input Low to High (100% Load) (Pad to R-cell Input)		1.1		1.3		1.5		2.1	ns
$t_{RCKL}$	Input High to Low (100% Load) (Pad to R-cell Input)		1.6		1.8		2.1		2.9	ns
$t_{RPWH}$	Minimum Pulse Width High	1.6		1.8		2.1		2.9		ns
$t_{RPWL}$	Minimum Pulse Width Low	1.6		1.8		2.1		2.9		ns
$t_{RCKSW}$	Maximum Skew (Light Load)		0.8		0.9		1.1		1.5	ns
$t_{RCKSW}$	Maximum Skew (50% Load)		0.8		1.0		1.1		1.5	ns
$t_{RCKSW}$	Maximum Skew (100% Load)		0.9		1.0		1.2		1.7	ns

Table 2-18 • A54SX08A Timing Characteristics  
(Worst-Case Commercial Conditions  $V_{CCA} = 2.25\text{ V}$ ,  $V_{CCI} = 2.3\text{ V}$ ,  $T_J = 70^\circ\text{C}$ )

Parameter	Description	-2 Speed		-1 Speed		Std. Speed		-F Speed		Units
		Min.	Max.	Min.	Max.	Min.	Max.	Min.	Max.	
<b>2.5 V LVCMOS Output Module Timing<sup>1,2</sup></b>										
$t_{DLH}$	Data-to-Pad Low to High		3.9		4.4		5.2		7.2	ns
$t_{DHL}$	Data-to-Pad High to Low		3.0		3.4		3.9		5.5	ns
$t_{DHLS}$	Data-to-Pad High to Low—low slew		13.3		15.1		17.7		24.8	ns
$t_{ENZL}$	Enable-to-Pad, Z to L		2.8		3.2		3.7		5.2	ns
$t_{ENZLS}$	Data-to-Pad, Z to L—low slew		13.7		15.5		18.2		25.5	ns
$t_{ENZH}$	Enable-to-Pad, Z to H		3.9		4.4		5.2		7.2	ns
$t_{ENLZ}$	Enable-to-Pad, L to Z		2.5		2.8		3.3		4.7	ns
$t_{ENHZ}$	Enable-to-Pad, H to Z		3.0		3.4		3.9		5.5	ns
$d_{TLH}^3$	Delta Low to High		0.037		0.043		0.051		0.071	ns/pF
$d_{THL}^3$	Delta High to Low		0.017		0.023		0.023		0.037	ns/pF
$d_{THLS}^3$	Delta High to Low—low slew		0.06		0.071		0.086		0.117	ns/pF

**Note:**

- Delays based on 35 pF loading.
- The equivalent I/O Attribute Editor settings for 2.5 V LVCMOS is 2.5 V LVTTTL in the software.
- To obtain the slew rate, substitute the appropriate Delta value, load capacitance, and the  $V_{CCI}$  value into the following equation:  

$$\text{Slew Rate [V/ns]} = (0.1 * V_{CCI} - 0.9 * V_{CCI}) / (C_{load} * d_{T[LH|HL|HLS]})$$
 where  $C_{load}$  is the load capacitance driven by the I/O in pF  
 $d_{T[LH|HL|HLS]}$  is the worst case delta value from the datasheet in ns/pF.

Table 2-19 • A54SX08A Timing Characteristics  
(Worst-Case Commercial Conditions  $V_{CCA} = 2.25\text{ V}$ ,  $V_{CCI} = 3.0\text{ V}$ ,  $T_J = 70^\circ\text{C}$ )

Parameter	Description	-2 Speed		-1 Speed		Std. Speed		-F Speed		Units
		Min.	Max.	Min.	Max.	Min.	Max.	Min.	Max.	
<b>3.3 V PCI Output Module Timing<sup>1</sup></b>										
$t_{DLH}$	Data-to-Pad Low to High		2.2		2.4		2.9		4.0	ns
$t_{DHL}$	Data-to-Pad High to Low		2.3		2.6		3.1		4.3	ns
$t_{ENZL}$	Enable-to-Pad, Z to L		1.7		1.9		2.2		3.1	ns
$t_{ENZH}$	Enable-to-Pad, Z to H		2.2		2.4		2.9		4.0	ns
$t_{ENLZ}$	Enable-to-Pad, L to Z		2.8		3.2		3.8		5.3	ns
$t_{ENHZ}$	Enable-to-Pad, H to Z		2.3		2.6		3.1		4.3	ns
$d_{TLH}^2$	Delta Low to High		0.03		0.03		0.04		0.045	ns/pF
$d_{THL}^2$	Delta High to Low		0.015		0.015		0.015		0.025	ns/pF
<b>3.3 V LVTTL Output Module Timing<sup>3</sup></b>										
$t_{DLH}$	Data-to-Pad Low to High		3.0		3.4		4.0		5.6	ns
$t_{DHL}$	Data-to-Pad High to Low		3.0		3.3		3.9		5.5	ns
$t_{DHLS}$	Data-to-Pad High to Low—low slew		10.4		11.8		13.8		19.3	ns
$t_{ENZL}$	Enable-to-Pad, Z to L		2.6		2.9		3.4		4.8	ns
$t_{ENZLS}$	Enable-to-Pad, Z to L—low slew		18.9		21.3		25.4		34.9	ns
$t_{ENZH}$	Enable-to-Pad, Z to H		3		3.4		4		5.6	ns
$t_{ENLZ}$	Enable-to-Pad, L to Z		3.3		3.7		4.4		6.2	ns
$t_{ENHZ}$	Enable-to-Pad, H to Z		3		3.3		3.9		5.5	ns
$d_{TLH}^2$	Delta Low to High		0.03		0.03		0.04		0.045	ns/pF
$d_{THL}^2$	Delta High to Low		0.015		0.015		0.015		0.025	ns/pF
$d_{THLS}^2$	Delta High to Low—low slew		0.053		0.067		0.073		0.107	ns/pF

**Notes:**

- Delays based on 10 pF loading and 25  $\Omega$  resistance.
- To obtain the slew rate, substitute the appropriate Delta value, load capacitance, and the  $V_{CCI}$  value into the following equation:  

$$\text{Slew Rate [V/ns]} = (0.1 * V_{CCI} - 0.9 * V_{CCI}) / (C_{load} * d_{T[LH|HL|HLS]})$$
 where  $C_{load}$  is the load capacitance driven by the I/O in pF  
 $d_{T[LH|HL|HLS]}$  is the worst case delta value from the datasheet in ns/pF.
- Delays based on 35 pF loading.

Table 2-20 • **A54SX08A Timing Characteristics**  
**(Worst-Case Commercial Conditions  $V_{CCA} = 2.25\text{ V}$ ,  $V_{CCI} = 4.75\text{ V}$ ,  $T_J = 70^\circ\text{C}$ )**

Parameter	Description	-2 Speed		-1 Speed		Std. Speed		-F Speed		Units
		Min.	Max.	Min.	Max.	Min.	Max.	Min.	Max.	
<b>5 V PCI Output Module Timing<sup>1</sup></b>										
$t_{DLH}$	Data-to-Pad Low to High		2.4		2.8		3.2		4.5	ns
$t_{DHL}$	Data-to-Pad High to Low		3.2		3.6		4.2		5.9	ns
$t_{ENZL}$	Enable-to-Pad, Z to L		1.5		1.7		2.0		2.8	ns
$t_{ENZH}$	Enable-to-Pad, Z to H		2.4		2.8		3.2		4.5	ns
$t_{ENLZ}$	Enable-to-Pad, L to Z		3.5		3.9		4.6		6.4	ns
$t_{ENHZ}$	Enable-to-Pad, H to Z		3.2		3.6		4.2		5.9	ns
$d_{TLH}^2$	Delta Low to High		0.016		0.02		0.022		0.032	ns/pF
$d_{THL}^2$	Delta High to Low		0.03		0.032		0.04		0.052	ns/pF
<b>5 V TTL Output Module Timing<sup>3</sup></b>										
$t_{DLH}$	Data-to-Pad Low to High		2.4		2.8		3.2		4.5	ns
$t_{DHL}$	Data-to-Pad High to Low		3.2		3.6		4.2		5.9	ns
$t_{DHLS}$	Data-to-Pad High to Low—low slew		7.6		8.6		10.1		14.2	ns
$t_{ENZL}$	Enable-to-Pad, Z to L		2.4		2.7		3.2		4.5	ns
$t_{ENZLS}$	Enable-to-Pad, Z to L—low slew		8.4		9.5		11.0		15.4	ns
$t_{ENZH}$	Enable-to-Pad, Z to H		2.4		2.8		3.2		4.5	ns
$t_{ENLZ}$	Enable-to-Pad, L to Z		4.2		4.7		5.6		7.8	ns
$t_{ENHZ}$	Enable-to-Pad, H to Z		3.2		3.6		4.2		5.9	ns
$d_{TLH}$	Delta Low to High		0.017		0.017		0.023		0.031	ns/pF
$d_{THL}$	Delta High to Low		0.029		0.031		0.037		0.051	ns/pF
$d_{THLS}$	Delta High to Low—low slew		0.046		0.057		0.066		0.089	ns/pF

**Notes:**

- Delays based on 50 pF loading.
- To obtain the slew rate, substitute the appropriate Delta value, load capacitance, and the  $V_{CCI}$  value into the following equation:  

$$\text{Slew Rate [V/ns]} = (0.1 * V_{CCI} - 0.9 * V_{CCI}) / (C_{load} * d_{T[HL|HL|HLS]})$$
 where  $C_{load}$  is the load capacitance driven by the I/O in pF  
 $d_{T[HL|HL|HLS]}$  is the worst case delta value from the datasheet in ns/pF.
- Delays based on 35 pF loading.

## SX-A Family FPGAs

Table 2-21 • A54SX16A Timing Characteristics  
(Worst-Case Commercial Conditions,  $V_{CCA} = 2.25\text{ V}$ ,  $V_{CCI} = 3.0\text{ V}$ ,  $T_J = 70^\circ\text{C}$ )

Parameter	Description	-3 Speed <sup>1</sup>		-2 Speed		-1 Speed		Std. Speed		-F Speed		Units
		Min.	Max.	Min.	Max.	Min.	Max.	Min.	Max.	Min.	Max.	
<b>C-Cell Propagation Delays<sup>2</sup></b>												
$t_{PD}$	Internal Array Module	0.9		1.0		1.2		1.4		1.9		ns
<b>Predicted Routing Delays<sup>3</sup></b>												
$t_{DC}$	FO = 1 Routing Delay, Direct Connect	0.1		0.1		0.1		0.1		0.1		ns
$t_{FC}$	FO = 1 Routing Delay, Fast Connect	0.3		0.3		0.3		0.4		0.6		ns
$t_{RD1}$	FO = 1 Routing Delay	0.3		0.3		0.4		0.5		0.6		ns
$t_{RD2}$	FO = 2 Routing Delay	0.4		0.5		0.5		0.6		0.8		ns
$t_{RD3}$	FO = 3 Routing Delay	0.5		0.6		0.7		0.8		1.1		ns
$t_{RD4}$	FO = 4 Routing Delay	0.7		0.8		0.9		1		1.4		ns
$t_{RD8}$	FO = 8 Routing Delay	1.2		1.4		1.5		1.8		2.5		ns
$t_{RD12}$	FO = 12 Routing Delay	1.7		2		2.2		2.6		3.6		ns
<b>R-Cell Timing</b>												
$t_{RCO}$	Sequential Clock-to-Q	0.6		0.7		0.8		0.9		1.3		ns
$t_{CLR}$	Asynchronous Clear-to-Q	0.5		0.6		0.6		0.8		1.0		ns
$t_{PRESET}$	Asynchronous Preset-to-Q	0.7		0.8		0.8		1.0		1.4		ns
$t_{SUD}$	Flip-Flop Data Input Set-Up	0.7		0.8		0.9		1.0		1.4		ns
$t_{HD}$	Flip-Flop Data Input Hold	0.0		0.0		0.0		0.0		0.0		ns
$t_{WASYN}$	Asynchronous Pulse Width	1.3		1.5		1.6		1.9		2.7		ns
$t_{RECA SYN}$	Asynchronous Recovery Time	0.3		0.4		0.4		0.5		0.7		ns
$t_{HASYN}$	Asynchronous Removal Time	0.3		0.3		0.3		0.4		0.6		ns
$t_{MPW}$	Clock Minimum Pulse Width	1.4		1.7		1.9		2.2		3.0		ns
<b>Input Module Propagation Delays</b>												
$t_{INYH}$	Input Data Pad to Y High 2.5 V LVCMOS	0.5		0.6		0.7		0.8		1.1		ns
$t_{INYL}$	Input Data Pad to Y Low 2.5 V LVCMOS	0.8		0.9		1.0		1.1		1.6		ns
$t_{INYH}$	Input Data Pad to Y High 3.3 V PCI	0.5		0.6		0.6		0.7		1.0		ns
$t_{INYL}$	Input Data Pad to Y Low 3.3 V PCI	0.7		0.8		0.9		1.0		1.4		ns
$t_{INYH}$	Input Data Pad to Y High 3.3 V LVTTTL	0.7		0.7		0.8		1.0		1.4		ns
$t_{INYL}$	Input Data Pad to Y Low 3.3 V LVTTTL	0.9		1.1		1.2		1.4		2.0		ns

### Notes:

1. All -3 speed grades have been discontinued.
2. For dual-module macros, use  $t_{PD} + t_{RD1} + t_{PDn}$ ,  $t_{RCO} + t_{RD1} + t_{PDn}$ , or  $t_{PD1} + t_{RD1} + t_{SUD}$ , whichever is appropriate.
3. Routing delays are for typical designs across worst-case operating conditions. These parameters should be used for estimating device performance. Post-route timing analysis or simulation is required to determine actual performance.

Table 2-21 • A54SX16A Timing Characteristics (Continued)  
 (Worst-Case Commercial Conditions,  $V_{CCA} = 2.25\text{ V}$ ,  $V_{CCI} = 3.0\text{ V}$ ,  $T_J = 70^\circ\text{C}$ )

Parameter	Description	-3 Speed <sup>1</sup>		-2 Speed		-1 Speed		Std. Speed		-F Speed		Units
		Min.	Max.	Min.	Max.	Min.	Max.	Min.	Max.	Min.	Max.	
$t_{INYH}$	Input Data Pad to Y High 5 V PCI		0.5		0.5		0.6		0.7		0.9	ns
$t_{INYL}$	Input Data Pad to Y Low 5 V PCI		0.7		0.8		0.9		1.1		1.5	ns
$t_{INYH}$	Input Data Pad to Y High 5 V TTL		0.5		0.5		0.6		0.7		0.9	ns
$t_{INYL}$	Input Data Pad to Y Low 5 V TTL		0.7		0.8		0.9		1.1		1.5	ns
<b>Input Module Predicted Routing Delays<sup>2</sup></b>												
$t_{IRD1}$	FO = 1 Routing Delay		0.3		0.3		0.3		0.4		0.6	ns
$t_{IRD2}$	FO = 2 Routing Delay		0.4		0.5		0.5		0.6		0.8	ns
$t_{IRD3}$	FO = 3 Routing Delay		0.5		0.6		0.7		0.8		1.1	ns
$t_{IRD4}$	FO = 4 Routing Delay		0.7		0.8		0.9		1.0		1.4	ns
$t_{IRD8}$	FO = 8 Routing Delay		1.2		1.4		1.5		0.8		2.5	ns
$t_{IRD12}$	FO = 12 Routing Delay		1.7		2.0		2.2		2.6		3.6	ns

**Notes:**

1. All -3 speed grades have been discontinued.
2. For dual-module macros, use  $t_{PD} + t_{RD1} + t_{PDn}$ ,  $t_{RCO} + t_{RD1} + t_{PDn}$ , or  $t_{PD1} + t_{RD1} + t_{SUD}$ , whichever is appropriate.
3. Routing delays are for typical designs across worst-case operating conditions. These parameters should be used for estimating device performance. Post-route timing analysis or simulation is required to determine actual performance.

Table 2-22 • A54SX16A Timing Characteristics  
(Worst-Case Commercial Conditions  $V_{CCA} = 2.25\text{ V}$ ,  $V_{CCI} = 2.25\text{ V}$ ,  $T_J = 70^\circ\text{C}$ )

Parameter	Description	-3 Speed*		-2 Speed		-1 Speed		Std. Speed		-F Speed		Units
		Min.	Max.	Min.	Max.	Min.	Max.	Min.	Max.	Min.	Max.	
<b>Dedicated (Hardwired) Array Clock Networks</b>												
$t_{HCKH}$	Input Low to High (Pad to R-cell Input)		1.2		1.4		1.6		1.8		2.8	ns
$t_{HCKL}$	Input High to Low (Pad to R-cell Input)		1.0		1.1		1.2		1.5		2.2	ns
$t_{HPWH}$	Minimum Pulse Width High	1.4		1.7		1.9		2.2		3.0		ns
$t_{HPWL}$	Minimum Pulse Width Low	1.4		1.7		1.9		2.2		3.0		ns
$t_{HCKSW}$	Maximum Skew		0.3		0.3		0.4		0.4		0.7	ns
$t_{HP}$	Minimum Period	2.8		3.4		3.8		4.4		6.0		ns
$f_{HMAX}$	Maximum Frequency		357		294		263		227		167	MHz
<b>Routed Array Clock Networks</b>												
$t_{RCKH}$	Input Low to High (Light Load) (Pad to R-cell Input)		1.0		1.2		1.3		1.6		2.2	ns
$t_{RCKL}$	Input High to Low (Light Load) (Pad to R-cell Input)		1.1		1.3		1.5		1.7		2.4	ns
$t_{RCKH}$	Input Low to High (50% Load) (Pad to R-cell Input)		1.1		1.3		1.5		1.7		2.4	ns
$t_{RCKL}$	Input High to Low (50% Load) (Pad to R-cell Input)		1.1		1.3		1.5		1.7		2.4	ns
$t_{RCKH}$	Input Low to High (100% Load) (Pad to R-cell Input)		1.3		1.5		1.7		2.0		2.8	ns
$t_{RCKL}$	Input High to Low (100% Load) (Pad to R-cell Input)		1.3		1.5		1.7		2.0		2.8	ns
$t_{RPWH}$	Minimum Pulse Width High	1.4		1.7		1.9		2.2		3.0		ns
$t_{RPWL}$	Minimum Pulse Width Low	1.4		1.7		1.9		2.2		3.0		ns
$t_{RCKSW}$	Maximum Skew (Light Load)		0.8		0.9		1.0		1.2		1.7	ns
$t_{RCKSW}$	Maximum Skew (50% Load)		0.8		0.9		1.0		1.2		1.7	ns
$t_{RCKSW}$	Maximum Skew (100% Load)		1.0		1.1		1.3		1.5		2.1	ns

**Note:** \*All -3 speed grades have been discontinued.

Table 2-23 • A54SX16A Timing Characteristics  
 (Worst-Case Commercial Conditions  $V_{CCA} = 2.25\text{ V}$ ,  $V_{CCI} = 3.0\text{ V}$ ,  $T_J = 70^\circ\text{C}$ )

Parameter	Description	-3 Speed*		-2 Speed		-1 Speed		Std. Speed		-F Speed		Units
		Min.	Max.	Min.	Max.	Min.	Max.	Min.	Max.	Min.	Max.	
<b>Dedicated (Hardwired) Array Clock Networks</b>												
$t_{HCKH}$	Input Low to High (Pad to R-cell Input)		1.2		1.4		1.6		1.8		2.8	ns
$t_{HCKL}$	Input High to Low (Pad to R-cell Input)		1.0		1.1		1.3		1.5		2.2	ns
$t_{HPWH}$	Minimum Pulse Width High	1.4		1.7		1.9		2.2		3.0		ns
$t_{HPWL}$	Minimum Pulse Width Low	1.4		1.7		1.9		2.2		3.0		ns
$t_{HCKSW}$	Maximum Skew		0.3		0.3		0.4		0.4		0.6	ns
$t_{HP}$	Minimum Period	2.8		3.4		3.8		4.4		6.0		ns
$f_{HMAX}$	Maximum Frequency		357		294		263		227		167	MHz
<b>Routed Array Clock Networks</b>												
$t_{RCKH}$	Input Low to High (Light Load) (Pad to R-cell Input)		1.0		1.2		1.3		1.5		2.1	ns
$t_{RCKL}$	Input High to Low (Light Load) (Pad to R-cell Input)		1.1		1.3		1.5		1.7		2.4	ns
$t_{RCKH}$	Input Low to High (50% Load) (Pad to R-cell Input)		1.1		1.3		1.4		1.7		2.3	ns
$t_{RCKL}$	Input High to Low (50% Load) (Pad to R-cell Input)		1.1		1.3		1.5		1.7		2.4	ns
$t_{RCKH}$	Input Low to High (100% Load) (Pad to R-cell Input)		1.3		1.5		1.7		2.0		2.7	ns
$t_{RCKL}$	Input High to Low (100% Load) (Pad to R-cell Input)		1.3		1.5		1.7		2.0		2.8	ns
$t_{RPWH}$	Minimum Pulse Width High	1.4		1.7		1.9		2.2		3.0		ns
$t_{RPWL}$	Minimum Pulse Width Low	1.4		1.7		1.9		2.2		3.0		ns
$t_{RCKSW}$	Maximum Skew (Light Load)		0.8		0.9		1.0		1.2		1.7	ns
$t_{RCKSW}$	Maximum Skew (50% Load)		0.8		0.9		1.0		1.2		1.7	ns
$t_{RCKSW}$	Maximum Skew (100% Load)		1.0		1.1		1.3		1.5		2.1	ns

**Note:** \*All -3 speed grades have been discontinued.

Table 2-24 • A54SX16A Timing Characteristics  
(Worst-Case Commercial Conditions  $V_{CCA} = 2.25\text{ V}$ ,  $V_{CCI} = 4.75\text{ V}$ ,  $T_J = 70^\circ\text{C}$ )

Parameter	Description	-3 Speed*		-2 Speed		-1 Speed		Std. Speed		-F Speed		Units
		Min.	Max.	Min.	Max.	Min.	Max.	Min.	Max.	Min.	Max.	
<b>Dedicated (Hardwired) Array Clock Networks</b>												
$t_{HCKH}$	Input Low to High (Pad to R-cell Input)		1.2		1.4		1.6		1.8		2.8	ns
$t_{HCKL}$	Input High to Low (Pad to R-cell Input)		1.0		1.1		1.2		1.5		2.2	ns
$t_{HPWH}$	Minimum Pulse Width High	1.4		1.7		1.9		2.2		3.0		ns
$t_{HPWL}$	Minimum Pulse Width Low	1.4		1.7		1.9		2.2		3.0		ns
$t_{HCKSW}$	Maximum Skew		0.3		0.3		0.4		0.4		0.7	ns
$t_{HP}$	Minimum Period	2.8		3.4		3.8		4.4		6.0		ns
$f_{HMAX}$	Maximum Frequency		357		294		263		227		167	MHz
<b>Routed Array Clock Networks</b>												
$t_{RCKH}$	Input Low to High (Light Load) (Pad to R-cell Input)		1.0		1.2		1.3		1.6		2.2	ns
$t_{RCKL}$	Input High to Low (Light Load) (Pad to R-cell Input)		1.1		1.3		1.5		1.7		2.4	ns
$t_{RCKH}$	Input Low to High (50% Load) (Pad to R-cell Input)		1.1		1.3		1.5		1.7		2.4	ns
$t_{RCKL}$	Input High to Low (50% Load) (Pad to R-cell Input)		1.1		1.3		1.5		1.7		2.4	ns
$t_{RCKH}$	Input Low to High (100% Load) (Pad to R-cell Input)		1.3		1.5		1.7		2.0		2.8	ns
$t_{RCKL}$	Input High to Low (100% Load) (Pad to R-cell Input)		1.3		1.5		1.7		2.0		2.8	ns
$t_{RPWH}$	Minimum Pulse Width High	1.4		1.7		1.9		2.2		3.0		ns
$t_{RPWL}$	Minimum Pulse Width Low	1.4		1.7		1.9		2.2		3.0		ns
$t_{RCKSW}$	Maximum Skew (Light Load)		0.8		0.9		1.0		1.2		1.7	ns
$t_{RCKSW}$	Maximum Skew (50% Load)		0.8		0.9		1.0		1.2		1.7	ns
$t_{RCKSW}$	Maximum Skew (100% Load)		1.0		1.1		1.3		1.5		2.1	ns

**Note:** \*All -3 speed grades have been discontinued.

Table 2-25 • A54SX16A Timing Characteristics  
(Worst-Case Commercial Conditions  $V_{CCA} = 2.25\text{ V}$ ,  $V_{CCI} = 2.25\text{ V}$ ,  $T_J = 70^\circ\text{C}$ )

Parameter	Description	-3 Speed <sup>1</sup>		-2 Speed		-1 Speed		Std. Speed		-F Speed		Units
		Min.	Max.	Min.	Max.	Min.	Max.	Min.	Max.	Min.	Max.	
<b>2.5 V LVCMOS Output Module Timing<sup>2, 3</sup></b>												
$t_{DLH}$	Data-to-Pad Low to High	3.4		3.9		4.5		5.2		7.3		ns
$t_{DHL}$	Data-to-Pad High to Low	2.6		3.0		3.3		3.9		5.5		ns
$t_{DHLS}$	Data-to-Pad High to Low—low slew	11.6		13.4		15.2		17.9		25.0		ns
$t_{ENZL}$	Enable-to-Pad, Z to L	2.4		2.8		3.2		3.7		5.2		ns
$t_{ENZLS}$	Data-to-Pad, Z to L—low slew	11.8		13.7		15.5		18.2		25.5		ns
$t_{ENZH}$	Enable-to-Pad, Z to H	3.4		3.9		4.5		5.2		7.3		ns
$t_{ENLZ}$	Enable-to-Pad, L to Z	2.1		2.5		2.8		3.3		4.7		ns
$t_{ENHZ}$	Enable-to-Pad, H to Z	2.6		3.0		3.3		3.9		5.5		ns
$d_{TLH}^4$	Delta Low to High	0.031		0.037		0.043		0.051		0.071		ns/pF
$d_{THL}^4$	Delta High to Low	0.017		0.017		0.023		0.023		0.037		ns/pF
$d_{THLS}^4$	Delta High to Low—low slew	0.057		0.06		0.071		0.086		0.117		ns/pF

**Note:**

1. All -3 speed grades have been discontinued.
2. Delays based on 35 pF loading.
3. The equivalent IO Attribute settings for 2.5 V LVCMOS is 2.5 V LVTTTL in the software.
4. To obtain the slew rate, substitute the appropriate Delta value, load capacitance, and the  $V_{CCI}$  value into the following equation:

$$\text{Slew Rate [V/ns]} = (0.1 * V_{CCI} - 0.9 * V_{CCI}) / (C_{load} * d_{T[LH|HL|HLS]})$$

where  $C_{load}$  is the load capacitance driven by the I/O in pF

$d_{T[LH|HL|HLS]}$  is the worst case delta value from the datasheet in ns/pF.

Table 2-26 • A54SX16A Timing Characteristics  
(Worst-Case Commercial Conditions  $V_{CCA} = 2.25\text{ V}$ ,  $V_{CCI} = 3.0\text{ V}$ ,  $T_J = 70^\circ\text{C}$ )

Parameter	Description	-3 Speed <sup>1</sup>		-2 Speed		-1 Speed		Std. Speed		-F Speed		Units
		Min.	Max.	Min.	Max.	Min.	Max.	Min.	Max.	Min.	Max.	
<b>3.3 V PCI Output Module Timing<sup>2</sup></b>												
$t_{DLH}$	Data-to-Pad Low to High	2.0	2.3	2.6	3.1	4.3	ns					
$t_{DHL}$	Data-to-Pad High to Low	2.2	2.5	2.8	3.3	4.6	ns					
$t_{ENZL}$	Enable-to-Pad, Z to L	1.4	1.7	1.9	2.2	3.1	ns					
$t_{ENZH}$	Enable-to-Pad, Z to H	2.0	2.3	2.6	3.1	4.3	ns					
$t_{ENLZ}$	Enable-to-Pad, L to Z	2.5	2.8	3.2	3.8	5.3	ns					
$t_{ENHZ}$	Enable-to-Pad, H to Z	2.2	2.5	2.8	3.3	4.6	ns					
$d_{TLH}^3$	Delta Low to High	0.025	0.03	0.03	0.04	0.045	ns/pF					
$d_{THL}^3$	Delta High to Low	0.015	0.015	0.015	0.015	0.025	ns/pF					
<b>3.3 V LVTTL Output Module Timing<sup>4</sup></b>												
$t_{DLH}$	Data-to-Pad Low to High	2.8	3.2	3.6	4.3	6.0	ns					
$t_{DHL}$	Data-to-Pad High to Low	2.7	3.1	3.5	4.1	5.7	ns					
$t_{DHLs}$	Data-to-Pad High to Low—low slew	9.5	10.9	12.4	14.6	20.4	ns					
$t_{ENZL}$	Enable-to-Pad, Z to L	2.2	2.6	2.9	3.4	4.8	ns					
$t_{ENZLS}$	Enable-to-Pad, Z to L—low slew	15.8	18.9	21.3	25.4	34.9	ns					
$t_{ENZH}$	Enable-to-Pad, Z to H	2.8	3.2	3.6	4.3	6.0	ns					
$t_{ENLZ}$	Enable-to-Pad, L to Z	2.9	3.3	3.7	4.4	6.2	ns					
$t_{ENHZ}$	Enable-to-Pad, H to Z	2.7	3.1	3.5	4.1	5.7	ns					
$d_{TLH}^3$	Delta Low to High	0.025	0.03	0.03	0.04	0.045	ns/pF					
$d_{THL}^3$	Delta High to Low	0.015	0.015	0.015	0.015	0.025	ns/pF					
$d_{THLS}^3$	Delta High to Low—low slew	0.053	0.053	0.067	0.073	0.107	ns/pF					

**Notes:**

1. All -3 speed grades have been discontinued.
2. Delays based on 10 pF loading and 25 Ω resistance.
3. To obtain the slew rate, substitute the appropriate Delta value, load capacitance, and the  $V_{CCI}$  value into the following equation:  

$$\text{Slew Rate [V/ns]} = (0.1 * V_{CCI} - 0.9 * V_{CCI}) / (C_{load} * d_{T[LH|HL|HLS]})$$
 where  $C_{load}$  is the load capacitance driven by the I/O in pF  
 $d_{T[LH|HL|HLS]}$  is the worst case delta value from the datasheet in ns/pF.
4. Delays based on 35 pF loading.

Table 2-27 • **A54SX16A Timing Characteristics**  
**(Worst-Case Commercial Conditions  $V_{CCA} = 2.25\text{ V}$ ,  $V_{CCI} = 4.75\text{ V}$ ,  $T_J = 70^\circ\text{C}$ )**

Parameter	Description	-3 Speed <sup>1</sup>		-2 Speed		-1 Speed		Std. Speed		-F Speed		Units
		Min.	Max.	Min.	Max.	Min.	Max.	Min.	Max.	Min.	Max.	
<b>5 V PCI Output Module Timing<sup>2</sup></b>												
$t_{DLH}$	Data-to-Pad Low to High	2.2	2.5	2.8	3.3	4.6	ns					
$t_{DHL}$	Data-to-Pad High to Low	2.8	3.2	3.6	4.2	5.9	ns					
$t_{ENZL}$	Enable-to-Pad, Z to L	1.3	1.5	1.7	2.0	2.8	ns					
$t_{ENZH}$	Enable-to-Pad, Z to H	2.2	2.5	2.8	3.3	4.6	ns					
$t_{ENLZ}$	Enable-to-Pad, L to Z	3.0	3.5	3.9	4.6	6.4	ns					
$t_{ENHZ}$	Enable-to-Pad, H to Z	2.8	3.2	3.6	4.2	5.9	ns					
$d_{TLH}^3$	Delta Low to High	0.016	0.016	0.02	0.022	0.032	ns/pF					
$d_{THL}^3$	Delta High to Low	0.026	0.03	0.032	0.04	0.052	ns/pF					
<b>5 V TTL Output Module Timing<sup>4</sup></b>												
$t_{DLH}$	Data-to-Pad Low to High	2.2	2.5	2.8	3.3	4.6	ns					
$t_{DHL}$	Data-to-Pad High to Low	2.8	3.2	3.6	4.2	5.9	ns					
$t_{DHLS}$	Data-to-Pad High to Low—low slew	6.7	7.7	8.7	10.2	14.3	ns					
$t_{ENZL}$	Enable-to-Pad, Z to L	2.1	2.4	2.7	3.2	4.5	ns					
$t_{ENZLS}$	Enable-to-Pad, Z to L—low slew	7.4	8.4	9.5	11.0	15.4	ns					
$t_{ENZH}$	Enable-to-Pad, Z to H	1.9	2.2	2.5	2.9	4.1	ns					
$t_{ENLZ}$	Enable-to-Pad, L to Z	3.6	4.2	4.7	5.6	7.8	ns					
$t_{ENHZ}$	Enable-to-Pad, H to Z	2.5	2.9	3.3	3.9	5.4	ns					
$d_{TLH}^3$	Delta Low to High	0.014	0.017	0.017	0.023	0.031	ns/pF					
$d_{THL}^3$	Delta High to Low	0.023	0.029	0.031	0.037	0.051	ns/pF					
$d_{THLS}^3$	Delta High to Low—low slew	0.043	0.046	0.057	0.066	0.089	ns/pF					

**Notes:**

1. All -3 speed grades have been discontinued.
2. Delays based on 50 pF loading.
3. To obtain the slew rate, substitute the appropriate Delta value, load capacitance, and the  $V_{CCI}$  value into the following equation:  

$$\text{Slew Rate [V/ns]} = (0.1 * V_{CCI} - 0.9 * V_{CCI}) / (C_{load} * d_{T[LH|HL|HLS]})$$
 where  $C_{load}$  is the load capacitance driven by the I/O in pF  
 $d_{T[LH|HL|HLS]}$  is the worst case delta value from the datasheet in ns/pF.
4. Delays based on 35 pF loading.

## SX-A Family FPGAs

Table 2-28 • A54SX32A Timing Characteristics  
(Worst-Case Commercial Conditions,  $V_{CCA} = 2.25\text{ V}$ ,  $V_{CCI} = 3.0\text{ V}$ ,  $T_J = 70^\circ\text{C}$ )

Parameter	Description	-3 Speed <sup>1</sup>		-2 Speed		-1 Speed		Std. Speed		-F Speed		Units
		Min.	Max.	Min.	Max.	Min.	Max.	Min.	Max.	Min.	Max.	
<b>C-Cell Propagation Delays<sup>2</sup></b>												
$t_{PD}$	Internal Array Module	0.8		0.9		1.1		1.2		1.7		ns
<b>Predicted Routing Delays<sup>3</sup></b>												
$t_{DC}$	FO = 1 Routing Delay, Direct Connect	0.1		0.1		0.1		0.1		0.1		ns
$t_{FC}$	FO = 1 Routing Delay, Fast Connect	0.3		0.3		0.3		0.4		0.6		ns
$t_{RD1}$	FO = 1 Routing Delay	0.3		0.3		0.4		0.5		0.6		ns
$t_{RD2}$	FO = 2 Routing Delay	0.4		0.5		0.5		0.6		0.8		ns
$t_{RD3}$	FO = 3 Routing Delay	0.5		0.6		0.7		0.8		1.1		ns
$t_{RD4}$	FO = 4 Routing Delay	0.7		0.8		0.9		1.0		1.4		ns
$t_{RD8}$	FO = 8 Routing Delay	1.2		1.4		1.5		1.8		2.5		ns
$t_{RD12}$	FO = 12 Routing Delay	1.7		2.0		2.2		2.6		3.6		ns
<b>R-Cell Timing</b>												
$t_{RCO}$	Sequential Clock-to-Q	0.6		0.7		0.8		0.9		1.3		ns
$t_{CLR}$	Asynchronous Clear-to-Q	0.5		0.6		0.6		0.8		1.0		ns
$t_{PRESET}$	Asynchronous Preset-to-Q	0.6		0.7		0.7		0.9		1.2		ns
$t_{SUD}$	Flip-Flop Data Input Set-Up	0.6		0.7		0.8		0.9		1.2		ns
$t_{HD}$	Flip-Flop Data Input Hold	0.0		0.0		0.0		0.0		0.0		ns
$t_{WASYN}$	Asynchronous Pulse Width	1.2		1.4		1.5		1.8		2.5		ns
$t_{REASYN}$	Asynchronous Recovery Time	0.3		0.4		0.4		0.5		0.7		ns
$t_{HASYN}$	Asynchronous Removal Time	0.3		0.3		0.3		0.4		0.6		ns
$t_{MPW}$	Clock Pulse Width	1.4		1.6		1.8		2.1		2.9		ns
<b>Input Module Propagation Delays</b>												
$t_{INYH}$	Input Data Pad to Y High 2.5 V LVCMOS	0.6		0.7		0.8		0.9		1.2		ns
$t_{INYL}$	Input Data Pad to Y Low 2.5 V LVCMOS	1.2		1.3		1.5		1.8		2.5		ns
$t_{INYH}$	Input Data Pad to Y High 3.3 V PCI	0.5		0.6		0.6		0.7		1.0		ns
$t_{INYL}$	Input Data Pad to Y Low 3.3 V PCI	0.6		0.7		0.8		0.9		1.3		ns
$t_{INYH}$	Input Data Pad to Y High 3.3 V LVTTTL	0.8		0.9		1.0		1.2		1.6		ns
$t_{INYL}$	Input Data Pad to Y Low 3.3 V LVTTTL	1.4		1.6		1.8		2.2		3.0		ns

### Notes:

1. All -3 speed grades have been discontinued.
2. For dual-module macros, use  $t_{PD} + t_{RD1} + t_{PDn}$ ,  $t_{RCO} + t_{RD1} + t_{PDn}$ , or  $t_{PD1} + t_{RD1} + t_{SUD}$ , whichever is appropriate.
3. Routing delays are for typical designs across worst-case operating conditions. These parameters should be used for estimating device performance. Post-route timing analysis or simulation is required to determine actual performance.

Table 2-28 • A54SX32A Timing Characteristics (Continued)  
 (Worst-Case Commercial Conditions,  $V_{CCA} = 2.25\text{ V}$ ,  $V_{CCI} = 3.0\text{ V}$ ,  $T_J = 70^\circ\text{C}$ )

Parameter	Description	-3 Speed <sup>1</sup>		-2 Speed		-1 Speed		Std. Speed		-F Speed		Units
		Min.	Max.	Min.	Max.	Min.	Max.	Min.	Max.	Min.	Max.	
$t_{INYH}$	Input Data Pad to Y High 5 V PCI		0.7		0.8		0.9		1.0		1.4	ns
$t_{INYL}$	Input Data Pad to Y Low 5 V PCI		0.9		1.1		1.2		1.4		1.9	ns
$t_{INYH}$	Input Data Pad to Y High 5 V TTL		0.9		1.1		1.2		1.4		1.9	ns
$t_{INYL}$	Input Data Pad to Y Low 5 V TTL		1.4		1.6		1.8		2.1		2.9	ns
<b>Input Module Predicted Routing Delays<sup>3</sup></b>												
$t_{IRD1}$	FO = 1 Routing Delay		0.3		0.3		0.3		0.4		0.6	ns
$t_{IRD2}$	FO = 2 Routing Delay		0.4		0.5		0.5		0.6		0.8	ns
$t_{IRD3}$	FO = 3 Routing Delay		0.5		0.6		0.7		0.8		1.1	ns
$t_{IRD4}$	FO = 4 Routing Delay		0.7		0.8		0.9		1		1.4	ns
$t_{IRD8}$	FO = 8 Routing Delay		1.2		1.4		1.5		1.8		2.5	ns
$t_{IRD12}$	FO = 12 Routing Delay		1.7		2		2.2		2.6		3.6	ns

**Notes:**

1. All -3 speed grades have been discontinued.
2. For dual-module macros, use  $t_{PD} + t_{RD1} + t_{PDn}$ ,  $t_{RCO} + t_{RD1} + t_{PDn}$ , or  $t_{PD1} + t_{RD1} + t_{SUD}$ , whichever is appropriate.
3. Routing delays are for typical designs across worst-case operating conditions. These parameters should be used for estimating device performance. Post-route timing analysis or simulation is required to determine actual performance.

Table 2-29 • A54SX32A Timing Characteristics  
(Worst-Case Commercial Conditions  $V_{CCA} = 2.25\text{ V}$ ,  $V_{CCI} = 2.25\text{ V}$ ,  $T_J = 70^\circ\text{C}$ )

Parameter	Description	-3 Speed*		-2 Speed		-1 Speed		Std. Speed		-F Speed		Units
		Min.	Max.	Min.	Max.	Min.	Max.	Min.	Max.	Min.	Max.	
<b>Dedicated (Hardwired) Array Clock Networks</b>												
$t_{HCKH}$	Input Low to High (Pad to R-cell Input)		1.7		2.0		2.2		2.6		4.0	ns
$t_{HCKL}$	Input High to Low (Pad to R-cell Input)		1.7		2.0		2.2		2.6		4.0	ns
$t_{HPWH}$	Minimum Pulse Width High	1.4		1.6		1.8		2.1		2.9		ns
$t_{HPWL}$	Minimum Pulse Width Low	1.4		1.6		1.8		2.1		2.9		ns
$t_{HCKSW}$	Maximum Skew		0.6		0.6		0.7		0.8		1.3	ns
$t_{HP}$	Minimum Period	2.8		3.2		3.6		4.2		5.8		ns
$f_{HMAX}$	Maximum Frequency		357		313		278		238		172	MHz
<b>Routed Array Clock Networks</b>												
$t_{RCKH}$	Input Low to High (Light Load) (Pad to R-cell Input)		2.2		2.5		2.9		3.4		4.7	ns
$t_{RCKL}$	Input High to Low (Light Load) (Pad to R-cell Input)		2.1		2.4		2.7		3.2		4.4	ns
$t_{RCKH}$	Input Low to High (50% Load) (Pad to R-cell Input)		2.4		2.7		3.1		3.6		5.1	ns
$t_{RCKL}$	Input High to Low (50% Load) (Pad to R-cell Input)		2.2		2.5		2.8		3.3		4.6	ns
$t_{RCKH}$	Input Low to High (100% Load) (Pad to R-cell Input)		2.5		2.9		3.2		3.8		5.3	ns
$t_{RCKL}$	Input High to Low (100% Load) (Pad to R-cell Input)		2.4		2.7		3.1		3.6		5.0	ns
$t_{RPWH}$	Minimum Pulse Width High	1.4		1.6		1.8		2.1		2.9		ns
$t_{RPWL}$	Minimum Pulse Width Low	1.4		1.6		1.8		2.1		2.9		ns
$t_{RCKSW}$	Maximum Skew (Light Load)		1.0		1.1		1.3		1.5		2.1	ns
$t_{RCKSW}$	Maximum Skew (50% Load)		0.9		1.0		1.2		1.4		1.9	ns
$t_{RCKSW}$	Maximum Skew (100% Load)		0.9		1.0		1.2		1.4		1.9	ns

**Note:** \*All -3 speed grades have been discontinued.

Table 2-30 • A54SX32A Timing Characteristics  
 (Worst-Case Commercial Conditions  $V_{CCA} = 2.25\text{ V}$ ,  $V_{CCI} = 3.0\text{ V}$ ,  $T_J = 70^\circ\text{C}$ )

Parameter	Description	-3 Speed*		-2 Speed		-1 Speed		Std. Speed		-F Speed		Units
		Min.	Max.	Min.	Max.	Min.	Max.	Min.	Max.	Min.	Max.	
<b>Dedicated (Hardwired) Array Clock Networks</b>												
$t_{HCKH}$	Input Low to High (Pad to R-cell Input)		1.7		2.0		2.2		2.6		4.0	ns
$t_{HCKL}$	Input High to Low (Pad to R-cell Input)		1.7		2.0		2.2		2.6		4.0	ns
$t_{HPWH}$	Minimum Pulse Width High	1.4		1.6		1.8		2.1		2.9		ns
$t_{HPWL}$	Minimum Pulse Width Low	1.4		1.6		1.8		2.1		2.9		ns
$t_{HCKSW}$	Maximum Skew		0.6		0.6		0.7		0.8		1.3	ns
$t_{HP}$	Minimum Period	2.8		3.2		3.6		4.2		5.8		ns
$f_{HMAX}$	Maximum Frequency		357		313		278		238		172	MHz
<b>Routed Array Clock Networks</b>												
$t_{RCKH}$	Input Low to High (Light Load) (Pad to R-cell Input)		2.2		2.5		2.8		3.3		4.6	ns
$t_{RCKL}$	Input High to Low (Light Load) (Pad to R-cell Input)		2.1		2.4		2.7		3.2		4.5	ns
$t_{RCKH}$	Input Low to High (50% Load) (Pad to R-cell Input)		2.3		2.7		3.1		3.6		5	ns
$t_{RCKL}$	Input High to Low (50% Load) (Pad to R-cell Input)		2.2		2.5		2.9		3.4		4.7	ns
$t_{RCKH}$	Input Low to High (100% Load) (Pad to R-cell Input)		2.4		2.8		3.2		3.7		5.2	ns
$t_{RCKL}$	Input High to Low (100% Load) (Pad to R-cell Input)		2.4		2.8		3.1		3.7		5.1	ns
$t_{RPWH}$	Minimum Pulse Width High	1.4		1.6		1.8		2.1		2.9		ns
$t_{RPWL}$	Minimum Pulse Width Low	1.4		1.6		1.8		2.1		2.9		ns
$t_{RCKSW}$	Maximum Skew (Light Load)		1.0		1.1		1.3		1.5		2.1	ns
$t_{RCKSW}$	Maximum Skew (50% Load)		0.9		1.0		1.2		1.4		1.9	ns
$t_{RCKSW}$	Maximum Skew (100% Load)		0.9		1.0		1.2		1.4		1.9	ns

**Note:** \*All -3 speed grades have been discontinued.

Table 2-31 • A54SX32A Timing Characteristics  
(Worst-Case Commercial Conditions  $V_{CCA} = 2.25\text{ V}$ ,  $V_{CCI} = 4.75\text{ V}$ ,  $T_J = 70^\circ\text{C}$ )

Parameter	Description	-3 Speed*		-2 Speed		-1 Speed		Std. Speed		-F Speed		Units
		Min.	Max.	Min.	Max.	Min.	Max.	Min.	Max.	Min.	Max.	
<b>Dedicated (Hardwired) Array Clock Networks</b>												
$t_{HCKH}$	Input Low to High (Pad to R-cell Input)		1.7		1.9		2.2		2.6		4.0	ns
$t_{HCKL}$	Input High to Low (Pad to R-cell Input)		1.7		2.0		2.2		2.6		4.0	ns
$t_{HPWH}$	Minimum Pulse Width High	1.4		1.6		1.8		2.1		2.9		ns
$t_{HPWL}$	Minimum Pulse Width Low	1.4		1.6		1.8		2.1		2.9		ns
$t_{HCKSW}$	Maximum Skew		0.6		0.6		0.7		0.8		1.3	ns
$t_{HP}$	Minimum Period	2.8		3.2		3.6		4.2		5.8		ns
$f_{HMAX}$	Maximum Frequency		357		313		278		238		172	MHz
<b>Routed Array Clock Networks</b>												
$t_{RCKH}$	Input Low to High (Light Load) (Pad to R-cell Input)		2.2		2.5		2.8		3.3		4.7	ns
$t_{RCKL}$	Input High to Low (Light Load) (Pad to R-cell Input)		2.1		2.5		2.8		3.3		4.5	ns
$t_{RCKH}$	Input Low to High (50% Load) (Pad to R-cell Input)		2.4		2.7		3.1		3.6		5.1	ns
$t_{RCKL}$	Input High to Low (50% Load) (Pad to R-cell Input)		2.2		2.6		2.9		3.4		4.7	ns
$t_{RCKH}$	Input Low to High (100% Load) (Pad to R-cell Input)		2.5		2.8		3.2		3.8		5.3	ns
$t_{RCKL}$	Input High to Low (100% Load) (Pad to R-cell Input)		2.4		2.8		3.1		3.7		5.2	ns
$t_{RPWH}$	Minimum Pulse Width High	1.4		1.6		1.8		2.1		2.9		ns
$t_{RPWL}$	Minimum Pulse Width Low	1.4		1.6		1.8		2.1		2.9		ns
$t_{RCKSW}$	Maximum Skew (Light Load)		1.0		1.1		1.3		1.5		2.1	ns
$t_{RCKSW}$	Maximum Skew (50% Load)		1.0		1.1		1.3		1.5		2.1	ns
$t_{RCKSW}$	Maximum Skew (100% Load)		1.0		1.1		1.3		1.5		2.1	ns

**Note:** \*All -3 speed grades have been discontinued.

Table 2-32 • A54SX32A Timing Characteristics  
 (Worst-Case Commercial Conditions  $V_{CCA} = 2.25\text{ V}$ ,  $V_{CCI} = 2.3\text{ V}$ ,  $T_J = 70^\circ\text{C}$ )

Parameter	Description	-3 Speed <sup>1</sup>		-2 Speed		-1 Speed		Std. Speed		-F Speed		Units
		Min.	Max.	Min.	Max.	Min.	Max.	Min.	Max.	Min.	Max.	
<b>2.5 V LVCMOS Output Module Timing<sup>2,3</sup></b>												
$t_{DLH}$	Data-to-Pad Low to High	3.3		3.8		4.2		5.0		7.0		ns
$t_{DHL}$	Data-to-Pad High to Low	2.5		2.9		3.2		3.8		5.3		ns
$t_{DHLS}$	Data-to-Pad High to Low—low slew	11.1		12.8		14.5		17.0		23.8		ns
$t_{ENZL}$	Enable-to-Pad, Z to L	2.4		2.8		3.2		3.7		5.2		ns
$t_{ENZLS}$	Data-to-Pad, Z to L—low slew	11.8		13.7		15.5		18.2		25.5		ns
$t_{ENZH}$	Enable-to-Pad, Z to H	3.3		3.8		4.2		5.0		7.0		ns
$t_{ENLZ}$	Enable-to-Pad, L to Z	2.1		2.5		2.8		3.3		4.7		ns
$t_{ENHZ}$	Enable-to-Pad, H to Z	2.5		2.9		3.2		3.8		5.3		ns
$d_{TLH}^4$	Delta Low to High	0.031		0.037		0.043		0.051		0.071		ns/pF
$d_{THL}^4$	Delta High to Low	0.017		0.017		0.023		0.023		0.037		ns/pF
$d_{THLS}^4$	Delta High to Low—low slew	0.057		0.06		0.071		0.086		0.117		ns/pF

**Note:**

1. All -3 speed grades have been discontinued.
2. Delays based on 35 pF loading.
3. The equivalent IO Attribute settings for 2.5 V LVCMOS is 2.5 V LVTTTL in the software.
4. To obtain the slew rate, substitute the appropriate Delta value, load capacitance, and the  $V_{CCI}$  value into the following equation:

$$\text{Slew Rate [V/ns]} = (0.1 * V_{CCI} - 0.9 * V_{CCI}) / (C_{load} * d_{T[LH|HL|HLS]})$$

where  $C_{load}$  is the load capacitance driven by the I/O in pF

$d_{T[LH|HL|HLS]}$  is the worst case delta value from the datasheet in ns/pF.

Table 2-33 • A54SX32A Timing Characteristics  
(Worst-Case Commercial Conditions  $V_{CCA} = 2.25\text{ V}$ ,  $V_{CCI} = 3.0\text{ V}$ ,  $T_J = 70^\circ\text{C}$ )

Parameter	Description	-3 Speed <sup>1</sup>		-2 Speed		-1 Speed		Std. Speed		-F Speed		Units
		Min.	Max.	Min.	Max.	Min.	Max.	Min.	Max.	Min.	Max.	
<b>3.3 V PCI Output Module Timing<sup>2</sup></b>												
$t_{DLH}$	Data-to-Pad Low to High	1.9	2.2	2.4	2.9	4.0	ns					
$t_{DHL}$	Data-to-Pad High to Low	2.0	2.3	2.6	3.1	4.3	ns					
$t_{ENZL}$	Enable-to-Pad, Z to L	1.4	1.7	1.9	2.2	3.1	ns					
$t_{ENZH}$	Enable-to-Pad, Z to H	1.9	2.2	2.4	2.9	4.0	ns					
$t_{ENLZ}$	Enable-to-Pad, L to Z	2.5	2.8	3.2	3.8	5.3	ns					
$t_{ENHZ}$	Enable-to-Pad, H to Z	2.0	2.3	2.6	3.1	4.3	ns					
$d_{TLH}^3$	Delta Low to High	0.025	0.03	0.03	0.04	0.045	ns/pF					
$d_{THL}^3$	Delta High to Low	0.015	0.015	0.015	0.015	0.025	ns/pF					
<b>3.3 V LVTTL Output Module Timing<sup>4</sup></b>												
$t_{DLH}$	Data-to-Pad Low to High	2.6	3.0	3.4	4.0	5.6	ns					
$t_{DHL}$	Data-to-Pad High to Low	2.6	3.0	3.3	3.9	5.5	ns					
$t_{DHLs}$	Data-to-Pad High to Low—low slew	9.0	10.4	11.8	13.8	19.3	ns					
$t_{ENZL}$	Enable-to-Pad, Z to L	2.2	2.6	2.9	3.4	4.8	ns					
$t_{ENZLS}$	Enable-to-Pad, Z to L—low slew	15.8	18.9	21.3	25.4	34.9	ns					
$t_{ENZH}$	Enable-to-Pad, Z to H	2.6	3.0	3.4	4.0	5.6	ns					
$t_{ENLZ}$	Enable-to-Pad, L to Z	2.9	3.3	3.7	4.4	6.2	ns					
$t_{ENHZ}$	Enable-to-Pad, H to Z	2.6	3.0	3.3	3.9	5.5	ns					
$d_{TLH}^3$	Delta Low to High	0.025	0.03	0.03	0.04	0.045	ns/pF					
$d_{THL}^3$	Delta High to Low	0.015	0.015	0.015	0.015	0.025	ns/pF					
$d_{THLS}^3$	Delta High to Low—low slew	0.053	0.053	0.067	0.073	0.107	ns/pF					

**Notes:**

1. All -3 speed grades have been discontinued.
2. Delays based on 10 pF loading and 25  $\Omega$  resistance.
3. To obtain the slew rate, substitute the appropriate Delta value, load capacitance, and the  $V_{CCI}$  value into the following equation:  

$$\text{Slew Rate [V/ns]} = (0.1 * V_{CCI} - 0.9 * V_{CCI}) / (C_{load} * d_{T[LH|HL|HLS]})$$
 where  $C_{load}$  is the load capacitance driven by the I/O in pF  
 $d_{T[LH|HL|HLS]}$  is the worst case delta value from the datasheet in ns/pF.
4. Delays based on 35 pF loading.

Table 2-34 • **A54SX32A Timing Characteristics**  
**(Worst-Case Commercial Conditions  $V_{CCA} = 2.25\text{ V}$ ,  $V_{CCI} = 4.75\text{ V}$ ,  $T_J = 70^\circ\text{C}$ )**

Parameter	Description	-3 Speed <sup>1</sup>		-2 Speed		-1 Speed		Std. Speed		-F Speed		Units
		Min.	Max.	Min.	Max.	Min.	Max.	Min.	Max.	Min.	Max.	
<b>5 V PCI Output Module Timing<sup>2</sup></b>												
$t_{DLH}$	Data-to-Pad Low to High	2.1	2.4	2.8	3.2	3.6	4.2	4.5	ns			
$t_{DHL}$	Data-to-Pad High to Low	2.8	3.2	3.6	4.2	4.5	5.9	ns				
$t_{ENZL}$	Enable-to-Pad, Z to L	1.3	1.5	1.7	2.0	2.8	4.5	ns				
$t_{ENZH}$	Enable-to-Pad, Z to H	2.1	2.4	2.8	3.2	3.6	4.2	5.9	ns			
$t_{ENLZ}$	Enable-to-Pad, L to Z	3.0	3.5	3.9	4.6	6.4	ns					
$t_{ENHZ}$	Enable-to-Pad, H to Z	2.8	3.2	3.6	4.2	5.9	ns					
$d_{TLH}^3$	Delta Low to High	0.016	0.016	0.02	0.022	0.032	ns/pF					
$d_{THL}^3$	Delta High to Low	0.026	0.03	0.032	0.04	0.052	ns/pF					
<b>5 V TTL Output Module Timing<sup>4</sup></b>												
$t_{DLH}$	Data-to-Pad Low to High	1.9	2.2	2.5	2.9	4.1	ns					
$t_{DHL}$	Data-to-Pad High to Low	2.5	2.9	3.3	3.9	5.4	ns					
$t_{DHLS}$	Data-to-Pad High to Low—low slew	6.6	7.6	8.6	10.1	14.2	ns					
$t_{ENZL}$	Enable-to-Pad, Z to L	2.1	2.4	2.7	3.2	4.5	ns					
$t_{ENZLS}$	Enable-to-Pad, Z to L—low slew	7.4	8.4	9.5	11.0	15.4	ns					
$t_{ENZH}$	Enable-to-Pad, Z to H	1.9	2.2	2.5	2.9	4.1	ns					
$t_{ENLZ}$	Enable-to-Pad, L to Z	3.6	4.2	4.7	5.6	7.8	ns					
$t_{ENHZ}$	Enable-to-Pad, H to Z	2.5	2.9	3.3	3.9	5.4	ns					
$d_{TLH}^3$	Delta Low to High	0.014	0.017	0.017	0.023	0.031	ns/pF					
$d_{THL}^3$	Delta High to Low	0.023	0.029	0.031	0.037	0.051	ns/pF					
$d_{THLS}^3$	Delta High to Low—low slew	0.043	0.046	0.057	0.066	0.089	ns/pF					

**Notes:**

1. All -3 speed grades have been discontinued.
2. Delays based on 50 pF loading.
3. To obtain the slew rate, substitute the appropriate Delta value, load capacitance, and the  $V_{CCI}$  value into the following equation:  

$$\text{Slew Rate [V/ns]} = (0.1 * V_{CCI} - 0.9 * V_{CCI}) / (C_{load} * d_{T[LH|HL|HLS]})$$
 where  $C_{load}$  is the load capacitance driven by the I/O in pF  
 $d_{T[LH|HL|HLS]}$  is the worst case delta value from the datasheet in ns/pF.
4. Delays based on 35 pF loading.

## SX-A Family FPGAs

Table 2-35 • A54SX72A Timing Characteristics  
(Worst-Case Commercial Conditions,  $V_{CCA} = 2.25\text{ V}$ ,  $V_{CCI} = 3.0\text{ V}$ ,  $T_J = 70^\circ\text{C}$ )

Parameter	Description	-3 Speed <sup>1</sup>		-2 Speed		-1 Speed		Std. Speed		-F Speed		Units
		Min.	Max.	Min.	Max.	Min.	Max.	Min.	Max.	Min.	Max.	
<b>C-Cell Propagation Delays<sup>2</sup></b>												
$t_{PD}$	Internal Array Module	1.0		1.1		1.3		1.5		2.0		ns
<b>Predicted Routing Delays<sup>3</sup></b>												
$t_{DC}$	FO = 1 Routing Delay, Direct Connect	0.1		0.1		0.1		0.1		0.1		ns
$t_{FC}$	FO = 1 Routing Delay, Fast Connect	0.3		0.3		0.3		0.4		0.6		ns
$t_{RD1}$	FO = 1 Routing Delay	0.3		0.3		0.4		0.5		0.7		ns
$t_{RD2}$	FO = 2 Routing Delay	0.4		0.5		0.6		0.7		1		ns
$t_{RD3}$	FO = 3 Routing Delay	0.5		0.7		0.8		0.9		1.3		ns
$t_{RD4}$	FO = 4 Routing Delay	0.7		0.9		1		1.1		1.5		ns
$t_{RD8}$	FO = 8 Routing Delay	1.2		1.5		1.7		2.1		2.9		ns
$t_{RD12}$	FO = 12 Routing Delay	1.7		2.2		2.5		3		4.2		ns
<b>R-Cell Timing</b>												
$t_{RCO}$	Sequential Clock-to-Q	0.7		0.8		0.9		1.1		1.5		ns
$t_{CLR}$	Asynchronous Clear-to-Q	0.6		0.7		0.7		0.9		1.2		ns
$t_{PRESET}$	Asynchronous Preset-to-Q	0.7		0.8		0.8		1.0		1.4		ns
$t_{SUD}$	Flip-Flop Data Input Set-Up	0.7		0.8		0.9		1.0		1.4		ns
$t_{HD}$	Flip-Flop Data Input Hold	0.0		0.0		0.0		0.0		0.0		ns
$t_{WASYN}$	Asynchronous Pulse Width	1.3		1.5		1.7		2.0		2.8		ns
$t_{REASYN}$	Asynchronous Recovery Time	0.3		0.4		0.4		0.5		0.7		ns
$t_{HASYN}$	Asynchronous Hold Time	0.3		0.3		0.3		0.4		0.6		ns
$t_{MPW}$	Clock Minimum Pulse Width	1.5		1.7		2.0		2.3		3.2		ns
<b>Input Module Propagation Delays</b>												
$t_{INYH}$	Input Data Pad to Y High 2.5 V LVCMOS	0.6		0.7		0.8		0.9		1.3		ns
$t_{INYL}$	Input Data Pad to Y Low 2.5 V LVCMOS	0.8		1.0		1.1		1.3		1.7		ns
$t_{INYH}$	Input Data Pad to Y High 3.3 V PCI	0.6		0.7		0.7		0.9		1.2		ns
$t_{INYL}$	Input Data Pad to Y Low 3.3 V PCI	0.7		0.8		0.9		1.0		1.4		ns
$t_{INYH}$	Input Data Pad to Y High 3.3 V LVTTTL	0.7		0.7		0.8		1.0		1.4		ns
$t_{INYL}$	Input Data Pad to Y Low 3.3 V LVTTTL	1.0		1.2		1.3		1.5		2.1		ns

### Notes:

1. All -3 speed grades have been discontinued.
2. For dual-module macros, use  $t_{PD} + t_{RD1} + t_{PDn}$ ,  $t_{RCO} + t_{RD1} + t_{PDn}$ , or  $t_{PD1} + t_{RD1} + t_{SUD}$ , whichever is appropriate.
3. Routing delays are for typical designs across worst-case operating conditions. These parameters should be used for estimating device performance. Post-route timing analysis or simulation is required to determine actual performance.

Table 2-35 • A54SX72A Timing Characteristics (Continued)  
 (Worst-Case Commercial Conditions,  $V_{CCA} = 2.25\text{ V}$ ,  $V_{CCI} = 3.0\text{ V}$ ,  $T_J = 70^\circ\text{C}$ )

Parameter	Description	-3 Speed <sup>1</sup>		-2 Speed		-1 Speed		Std. Speed		-F Speed		Units
		Min.	Max.	Min.	Max.	Min.	Max.	Min.	Max.	Min.	Max.	
$t_{INYH}$	Input Data Pad to Y High 5 V PCI		0.5		0.6		0.7		0.8		1.1	ns
$t_{INYL}$	Input Data Pad to Y Low 5 V PCI		0.8		0.9		1.0		1.2		1.6	ns
$t_{INYH}$	Input Data Pad to Y High 5 V TTL		0.7		0.8		0.9		1.0		1.4	ns
$t_{INYL}$	Input Data Pad to Y Low 5 V TTL		0.9		1.1		1.2		1.4		1.9	ns
<b>Input Module Predicted Routing Delays<sup>3</sup></b>												
$t_{IRD1}$	FO = 1 Routing Delay		0.3		0.3		0.4		0.5		0.7	ns
$t_{IRD2}$	FO = 2 Routing Delay		0.4		0.5		0.6		0.7		1	ns
$t_{IRD3}$	FO = 3 Routing Delay		0.5		0.7		0.8		0.9		1.3	ns
$t_{IRD4}$	FO = 4 Routing Delay		0.7		0.9		1		1.1		1.5	ns
$t_{IRD8}$	FO = 8 Routing Delay		1.2		1.5		1.7		2.1		2.9	ns
$t_{IRD12}$	FO = 12 Routing Delay		1.7		2.2		2.5		3		4.2	ns

**Notes:**

1. All -3 speed grades have been discontinued.
2. For dual-module macros, use  $t_{PD} + t_{RD1} + t_{PDn}$ ,  $t_{RCO} + t_{RD1} + t_{PDn}$ , or  $t_{PD1} + t_{RD1} + t_{SUD}$ , whichever is appropriate.
3. Routing delays are for typical designs across worst-case operating conditions. These parameters should be used for estimating device performance. Post-route timing analysis or simulation is required to determine actual performance.

Table 2-36 • A54SX72A Timing Characteristics  
(Worst-Case Commercial Conditions  $V_{CCA} = 2.25\text{ V}$ ,  $V_{CCI} = 2.25\text{ V}$ ,  $T_J = 70^\circ\text{C}$ )

Parameter	Description	-3 Speed*		-2 Speed		-1 Speed		Std. Speed		-F Speed		Units
		Min.	Max.	Min.	Max.	Min.	Max.	Min.	Max.	Min.	Max.	
<b>Dedicated (Hardwired) Array Clock Networks</b>												
t <sub>HCKH</sub>	Input Low to High (Pad to R-cell Input)		1.6		1.9		2.1		2.5		3.8	ns
t <sub>HCKL</sub>	Input High to Low (Pad to R-cell Input)		1.6		1.9		2.1		2.5		3.8	ns
t <sub>HPWH</sub>	Minimum Pulse Width High	1.5		1.7		2.0		2.3		3.2		ns
t <sub>HPWL</sub>	Minimum Pulse Width Low	1.5		1.7		2.0		2.3		3.2		ns
t <sub>HCKSW</sub>	Maximum Skew		1.4		1.6		1.8		2.1		3.3	ns
t <sub>HP</sub>	Minimum Period	3.0		3.4		4.0		4.6		6.4		ns
f <sub>HMAX</sub>	Maximum Frequency		333		294		250		217		156	MHz
<b>Routed Array Clock Networks</b>												
t <sub>RCKH</sub>	Input Low to High (Light Load) (Pad to R-cell Input)		2.3		2.6		2.9		3.4		4.8	ns
t <sub>RCKL</sub>	Input High to Low (Light Load) (Pad to R-cell Input)		2.8		3.2		3.7		4.3		6.0	ns
t <sub>RCKH</sub>	Input Low to High (50% Load) (Pad to R-cell Input)		2.4		2.8		3.2		3.7		5.2	ns
t <sub>RCKL</sub>	Input High to Low (50% Load) (Pad to R-cell Input)		2.9		3.3		3.8		4.5		6.2	ns
t <sub>RCKH</sub>	Input Low to High (100% Load) (Pad to R-cell Input)		2.6		3.0		3.4		4.0		5.6	ns
t <sub>RCKL</sub>	Input High to Low (100% Load) (Pad to R-cell Input)		3.1		3.6		4.0		4.7		6.6	ns
t <sub>RPWH</sub>	Minimum Pulse Width High	1.5		1.7		2.0		2.3		3.2		ns
t <sub>RPWL</sub>	Minimum Pulse Width Low	1.5		1.7		2.0		2.3		3.2		ns
t <sub>RCKSW</sub>	Maximum Skew (Light Load)		1.9		2.2		2.5		3.0		4.1	ns
t <sub>RCKSW</sub>	Maximum Skew (50% Load)		1.8		2.1		2.4		2.8		3.9	ns
t <sub>RCKSW</sub>	Maximum Skew (100% Load)		1.8		2.1		2.4		2.8		3.9	ns
<b>Quadrant Array Clock Networks</b>												
t <sub>QCKH</sub>	Input Low to High (Light Load) (Pad to R-cell Input)		2.6		3.0		3.4		4.0		5.6	ns
t <sub>QCHL</sub>	Input High to Low (Light Load) (Pad to R-cell Input)		2.6		3.0		3.3		3.9		5.5	ns
t <sub>QCKH</sub>	Input Low to High (50% Load) (Pad to R-cell Input)		2.8		3.2		3.6		4.3		6.0	ns
t <sub>QCHL</sub>	Input High to Low (50% Load) (Pad to R-cell Input)		2.8		3.2		3.6		4.2		5.9	ns

**Note:** \*All -3 speed grades have been discontinued.

Table 2-36 • A54SX72A Timing Characteristics (Continued)  
 (Worst-Case Commercial Conditions  $V_{CCA} = 2.25\text{ V}$ ,  $V_{CCI} = 2.25\text{ V}$ ,  $T_J = 70^\circ\text{C}$ )

Parameter	Description	-3 Speed*		-2 Speed		-1 Speed		Std. Speed		-F Speed		Units
		Min.	Max.	Min.	Max.	Min.	Max.	Min.	Max.	Min.	Max.	
$t_{QCKH}$	Input Low to High (100% Load) (Pad to R-cell Input)		3.0		3.4		3.9		4.6		6.4	ns
$t_{QCHKL}$	Input High to Low (100% Load) (Pad to R-cell Input)		2.9		3.4		3.8		4.5		6.3	ns
$t_{QPWH}$	Minimum Pulse Width High	1.5		1.7		2.0		2.3		3.2		ns
$t_{QPWL}$	Minimum Pulse Width Low	1.5		1.7		2.0		2.3		3.2		ns
$t_{QCKSW}$	Maximum Skew (Light Load)		0.2		0.3		0.3		0.3		0.5	ns
$t_{QCKSW}$	Maximum Skew (50% Load)		0.4		0.5		0.5		0.6		0.9	ns
$t_{QCKSW}$	Maximum Skew (100% Load)		0.4		0.5		0.5		0.6		0.9	ns

**Note:** \*All -3 speed grades have been discontinued.

Table 2-37 • A54SX72A Timing Characteristics  
(Worst-Case Commercial Conditions  $V_{CCA} = 2.25\text{ V}$ ,  $V_{CCI} = 3.0\text{ V}$ ,  $T_J = 70^\circ\text{C}$ )

Parameter	Description	-3 Speed*		-2 Speed		-1 Speed		Std. Speed		-F Speed		Units
		Min.	Max.	Min.	Max.	Min.	Max.	Min.	Max.	Min.	Max.	
<b>Dedicated (Hardwired) Array Clock Networks</b>												
t <sub>HCKH</sub>	Input Low to High (Pad to R-cell Input)		1.6		1.9		2.1		2.5		3.8	ns
t <sub>HCKL</sub>	Input High to Low (Pad to R-cell Input)		1.7		1.9		2.1		2.5		3.8	ns
t <sub>HPWH</sub>	Minimum Pulse Width High	1.5		1.7		2.0		2.3		3.2		ns
t <sub>HPWL</sub>	Minimum Pulse Width Low	1.5		1.7		2.0		2.3		3.2		ns
t <sub>HCKSW</sub>	Maximum Skew		1.4		1.6		1.8		2.1		3.3	ns
t <sub>HP</sub>	Minimum Period	3.0		3.4		4.0		4.6		6.4		ns
f <sub>HMAX</sub>	Maximum Frequency		333		294		250		217		156	MHz
<b>Routed Array Clock Networks</b>												
t <sub>RCKH</sub>	Input Low to High (Light Load) (Pad to R-cell Input)		2.2		2.6		2.9		3.4		4.8	ns
t <sub>RCKL</sub>	Input High to Low (Light Load) (Pad to R-cell Input)		2.8		3.3		3.7		4.3		6.0	ns
t <sub>RCKH</sub>	Input Low to High (50% Load) (Pad to R-cell Input)		2.4		2.8		3.2		3.7		5.2	ns
t <sub>RCKL</sub>	Input High to Low (50% Load) (Pad to R-cell Input)		2.9		3.4		3.8		4.5		6.2	ns
t <sub>RCKH</sub>	Input Low to High (100% Load) (Pad to R-cell Input)		2.6		3.0		3.4		4.0		5.6	ns
t <sub>RCKL</sub>	Input High to Low (100% Load) (Pad to R-cell Input)		3.1		3.6		4.1		4.8		6.7	ns
t <sub>RPWH</sub>	Minimum Pulse Width High	1.5		1.7		2.0		2.3		3.2		ns
t <sub>RPWL</sub>	Minimum Pulse Width Low	1.5		1.7		2.0		2.3		3.2		ns
t <sub>RCKSW</sub>	Maximum Skew (Light Load)		1.9		2.2		2.5		3		4.1	ns
t <sub>RCKSW</sub>	Maximum Skew (50% Load)		1.9		2.1		2.4		2.8		3.9	ns
t <sub>RCKSW</sub>	Maximum Skew (100% Load)		1.9		2.1		2.4		2.8		3.9	ns
<b>Quadrant Array Clock Networks</b>												
t <sub>QCKH</sub>	Input Low to High (Light Load) (Pad to R-cell Input)		1.3		1.5		1.7		1.9		2.7	ns
t <sub>QCHL</sub>	Input High to Low (Light Load) (Pad to R-cell Input)		1.3		1.5		1.7		2		2.8	ns
t <sub>QCKH</sub>	Input Low to High (50% Load) (Pad to R-cell Input)		1.5		1.7		1.9		2.2		3.1	ns
t <sub>QCHL</sub>	Input High to Low (50% Load) (Pad to R-cell Input)		1.5		1.8		2		2.3		3.2	ns

**Note:** \*All -3 speed grades have been discontinued.

Table 2-37 • A54SX72A Timing Characteristics (Continued)  
 (Worst-Case Commercial Conditions  $V_{CCA} = 2.25\text{ V}$ ,  $V_{CCI} = 3.0\text{ V}$ ,  $T_J = 70^\circ\text{C}$ )

Parameter	Description	-3 Speed*		-2 Speed		-1 Speed		Std. Speed		-F Speed		Units
		Min.	Max.	Min.	Max.	Min.	Max.	Min.	Max.	Min.	Max.	
$t_{QCKH}$	Input Low to High (100% Load) (Pad to R-cell Input)		1.7		1.9		2.2		2.5		3.5	ns
$t_{QCHKL}$	Input High to Low (100% Load) (Pad to R-cell Input)		1.7		2		2.2		2.6		3.6	ns
$t_{QPWH}$	Minimum Pulse Width High	1.5		1.7		2.0		2.3		3.2		ns
$t_{QPWL}$	Minimum Pulse Width Low	1.5		1.7		2.0		2.3		3.2		ns
$t_{QCKSW}$	Maximum Skew (Light Load)		0.2		0.3		0.3		0.3		0.5	ns
$t_{QCKSW}$	Maximum Skew (50% Load)		0.4		0.5		0.5		0.6		0.9	ns
$t_{QCKSW}$	Maximum Skew (100% Load)		0.4		0.5		0.5		0.6		0.9	ns

**Note:** \*All -3 speed grades have been discontinued.

Table 2-38 • A54SX72A Timing Characteristics  
(Worst-Case Commercial Conditions  $V_{CCA} = 2.25\text{ V}$ ,  $V_{CCI} = 4.75\text{ V}$ ,  $T_J = 70^\circ\text{C}$ )

Parameter	Description	-3 Speed*		-2 Speed		-1 Speed		Std. Speed		-F Speed		Units
		Min.	Max.	Min.	Max.	Min.	Max.	Min.	Max.	Min.	Max.	
<b>Dedicated (Hardwired) Array Clock Networks</b>												
t <sub>HCKH</sub>	Input Low to High (Pad to R-cell Input)		1.6		1.8		2.1		2.4		3.8	ns
t <sub>HCKL</sub>	Input High to Low (Pad to R-cell Input)		1.6		1.9		2.1		2.5		3.8	ns
t <sub>HPWH</sub>	Minimum Pulse Width High	1.5		1.7		2.0		2.3		3.2		ns
t <sub>HPWL</sub>	Minimum Pulse Width Low	1.5		1.7		2.0		2.3		3.2		ns
t <sub>HCKSW</sub>	Maximum Skew		1.4		1.6		1.8		2.1		3.3	ns
t <sub>HP</sub>	Minimum Period	3.0		3.4		4.0		4.6		6.4		ns
f <sub>HMAX</sub>	Maximum Frequency		333		294		250		217		156	MHz
<b>Routed Array Clock Networks</b>												
t <sub>RCKH</sub>	Input Low to High (Light Load) (Pad to R-cell Input)		2.3		2.6		3.0		3.5		4.9	ns
t <sub>RCKL</sub>	Input High to Low (Light Load) (Pad to R-cell Input)		2.8		3.2		3.6		4.3		6.0	ns
t <sub>RCKH</sub>	Input Low to High (50% Load) (Pad to R-cell Input)		2.5		2.9		3.2		3.8		5.3	ns
t <sub>RCKL</sub>	Input High to Low (50% Load) (Pad to R-cell Input)		3.0		3.4		3.9		4.6		6.4	ns
t <sub>RCKH</sub>	Input Low to High (100% Load) (Pad to R-cell Input)		2.6		3.0		3.4		3.9		5.5	ns
t <sub>RCKL</sub>	Input High to Low (100% Load) (Pad to R-cell Input)		3.2		3.6		4.1		4.8		6.8	ns
t <sub>RPWH</sub>	Minimum Pulse Width High	1.5		1.7		2.0		2.3		3.2		ns
t <sub>RPWL</sub>	Minimum Pulse Width Low	1.5		1.7		2.0		2.3		3.2		ns
t <sub>RCKSW</sub>	Maximum Skew (Light Load)		1.9		2.2		2.5		3.0		4.1	ns
t <sub>RCKSW</sub>	Maximum Skew (50% Load)		1.9		2.2		2.5		3.0		4.1	ns
t <sub>RCKSW</sub>	Maximum Skew (100% Load)		1.9		2.2		2.5		3.0		4.1	ns
<b>Quadrant Array Clock Networks</b>												
t <sub>QCKH</sub>	Input Low to High (Light Load) (Pad to R-cell Input)		1.2		1.4		1.6		1.8		2.6	ns
t <sub>QCHL</sub>	Input High to Low (Light Load) (Pad to R-cell Input)		1.3		1.4		1.6		1.9		2.7	ns
t <sub>QCKH</sub>	Input Low to High (50% Load) (Pad to R-cell Input)		1.4		1.6		1.8		2.1		3.0	ns
t <sub>QCHL</sub>	Input High to Low (50% Load) (Pad to R-cell Input)		1.4		1.7		1.9		2.2		3.1	ns

**Note:** \*All -3 speed grades have been discontinued.

Table 2-38 • A54SX72A Timing Characteristics (Continued)  
 (Worst-Case Commercial Conditions  $V_{CCA} = 2.25\text{ V}$ ,  $V_{CCI} = 4.75\text{ V}$ ,  $T_J = 70^\circ\text{C}$ )

Parameter	Description	-3 Speed*		-2 Speed		-1 Speed		Std. Speed		-F Speed		Units
		Min.	Max.	Min.	Max.	Min.	Max.	Min.	Max.	Min.	Max.	
$t_{QCKH}$	Input Low to High (100% Load) (Pad to R-cell Input)		1.6		1.8		2.1		2.4		3.4	ns
$t_{QCHKL}$	Input High to Low (100% Load) (Pad to R-cell Input)		1.6		1.9		2.1		2.5		3.5	ns
$t_{QPWH}$	Minimum Pulse Width High	1.5		1.7		2.0		2.3		3.2		ns
$t_{QPWL}$	Minimum Pulse Width Low	1.5		1.7		2.0		2.3		3.2		ns
$t_{QCKSW}$	Maximum Skew (Light Load)		0.2		0.3		0.3		0.3		0.5	ns
$t_{QCKSW}$	Maximum Skew (50% Load)		0.4		0.5		0.5		0.6		0.9	ns
$t_{QCKSW}$	Maximum Skew (100% Load)		0.4		0.5		0.5		0.6		0.9	ns

**Note:** \*All -3 speed grades have been discontinued.

Table 2-39 • A54SX72A Timing Characteristics  
(Worst-Case Commercial Conditions  $V_{CCA} = 2.25\text{ V}$ ,  $V_{CCI} = 2.3\text{ V}$ ,  $T_J = 70^\circ\text{C}$ )

Parameter	Description	-3 Speed <sup>1</sup>		-2 Speed		-1 Speed		Std. Speed		-F Speed		Units
		Min.	Max.	Min.	Max.	Min.	Max.	Min.	Max.	Min.	Max.	
<b>2.5 V LVCMOS Output Module Timing<sup>2, 3</sup></b>												
$t_{DLH}$	Data-to-Pad Low to High	3.9		4.5		5.1		6.0		8.4		ns
$t_{DHL}$	Data-to-Pad High to Low	3.1		3.6		4.1		4.8		6.7		ns
$t_{DHLS}$	Data-to-Pad High to Low—low slew	12.7		14.6		16.5		19.4		27.2		ns
$t_{ENZL}$	Enable-to-Pad, Z to L	2.4		2.8		3.2		3.7		5.2		ns
$t_{ENZLS}$	Data-to-Pad, Z to L—low slew	11.8		13.7		15.5		18.2		25.5		ns
$t_{ENZH}$	Enable-to-Pad, Z to H	3.9		4.5		5.1		6.0		8.4		ns
$t_{ENLZ}$	Enable-to-Pad, L to Z	2.1		2.5		2.8		3.3		4.7		ns
$t_{ENHZ}$	Enable-to-Pad, H to Z	3.1		3.6		4.1		4.8		6.7		ns
$d_{TLH}^4$	Delta Low to High	0.031		0.037		0.043		0.051		0.071		ns/pF
$d_{THL}^4$	Delta High to Low	0.017		0.017		0.023		0.023		0.037		ns/pF
$d_{THLS}^4$	Delta High to Low—low slew	0.057		0.06		0.071		0.086		0.117		ns/pF

**Note:**

1. All -3 speed grades have been discontinued.
2. Delays based on 35 pF loading.
3. The equivalent IO Attribute settings for 2.5 V LVCMOS is 2.5 V LVTTTL in the software.
4. To obtain the slew rate, substitute the appropriate Delta value, load capacitance, and the  $V_{CCI}$  value into the following equation:  

$$\text{Slew Rate [V/ns]} = (0.1 * V_{CCI} - 0.9 * V_{CCI}) / (C_{load} * d_{T[LH|HL|HLS]})$$
 where  $C_{load}$  is the load capacitance driven by the I/O in pF  
 $d_{T[LH|HL|HLS]}$  is the worst case delta value from the datasheet in ns/pF.

Table 2-40 • A54SX72A Timing Characteristics  
(Worst-Case Commercial Conditions  $V_{CCA} = 2.25\text{ V}$ ,  $V_{CCI} = 3.0\text{ V}$ ,  $T_J = 70^\circ\text{C}$ )

Parameter	Description	-3 Speed <sup>1</sup>		-2 Speed		-1 Speed		Std. Speed		-F Speed		Units
		Min.	Max.	Min.	Max.	Min.	Max.	Min.	Max.	Min.	Max.	
<b>3.3 V PCI Output Module Timing<sup>2</sup></b>												
$t_{DLH}$	Data-to-Pad Low to High		2.3		2.7		3.0		3.6		5.0	ns
$t_{DHL}$	Data-to-Pad High to Low		2.5		2.9		3.2		3.8		5.3	ns
$t_{ENZL}$	Enable-to-Pad, Z to L		1.4		1.7		1.9		2.2		3.1	ns
$t_{ENZH}$	Enable-to-Pad, Z to H		2.3		2.7		3.0		3.6		5.0	ns
$t_{ENLZ}$	Enable-to-Pad, L to Z		2.5		2.8		3.2		3.8		5.3	ns
$t_{ENHZ}$	Enable-to-Pad, H to Z		2.5		2.9		3.2		3.8		5.3	ns
$d_{TLH}^3$	Delta Low to High		0.025		0.03		0.03		0.04		0.045	ns/pF
$d_{THL}^3$	Delta High to Low		0.015		0.015		0.015		0.015		0.025	ns/pF
<b>3.3 V LVTTL Output Module Timing<sup>4</sup></b>												
$t_{DLH}$	Data-to-Pad Low to High		3.2		3.7		4.2		5.0		6.9	ns
$t_{DHL}$	Data-to-Pad High to Low		3.2		3.7		4.2		4.9		6.9	ns
$t_{DHLs}$	Data-to-Pad High to Low—low slew		10.3		11.9		13.5		15.8		22.2	ns
$t_{ENZL}$	Enable-to-Pad, Z to L		2.2		2.6		2.9		3.4		4.8	ns
$t_{ENZLS}$	Enable-to-Pad, Z to L—low slew		15.8		18.9		21.3		25.4		34.9	ns
$t_{ENZH}$	Enable-to-Pad, Z to H		3.2		3.7		4.2		5.0		6.9	ns
$t_{ENLZ}$	Enable-to-Pad, L to Z		2.9		3.3		3.7		4.4		6.2	ns
$t_{ENHZ}$	Enable-to-Pad, H to Z		3.2		3.7		4.2		4.9		6.9	ns
$d_{TLH}^3$	Delta Low to High		0.025		0.03		0.03		0.04		0.045	ns/pF
$d_{THL}^3$	Delta High to Low		0.015		0.015		0.015		0.015		0.025	ns/pF
$d_{THLS}^3$	Delta High to Low—low slew		0.053		0.053		0.067		0.073		0.107	ns/pF

**Notes:**

- All -3 speed grades have been discontinued.
- Delays based on 10 pF loading and 25  $\Omega$  resistance.
- To obtain the slew rate, substitute the appropriate Delta value, load capacitance, and the  $V_{CCI}$  value into the following equation:  

$$\text{Slew Rate [V/ns]} = (0.1 * V_{CCI} - 0.9 * V_{CCI}) / (C_{load} * d_{T[LH|HL|HLS]})$$
 where  $C_{load}$  is the load capacitance driven by the I/O in pF  
 $d_{T[LH|HL|HLS]}$  is the worst case delta value from the datasheet in ns/pF.
- Delays based on 35 pF loading.

Table 2-41 • A54SX72A Timing Characteristics  
(Worst-Case Commercial Conditions  $V_{CCA} = 2.25\text{ V}$ ,  $V_{CCI} = 4.75\text{ V}$ ,  $T_J = 70^\circ\text{C}$ )

Parameter	Description	-3 Speed <sup>1</sup>		-2 Speed		-1 Speed		Std. Speed		-F Speed		Units
		Min.	Max.	Min.	Max.	Min.	Max.	Min.	Max.	Min.	Max.	
<b>5 V PCI Output Module Timing<sup>2</sup></b>												
$t_{DLH}$	Data-to-Pad Low to High		2.7		3.1		3.5		4.1		5.7	ns
$t_{DHL}$	Data-to-Pad High to Low		3.4		3.9		4.4		5.1		7.2	ns
$t_{ENZL}$	Enable-to-Pad, Z to L		1.3		1.5		1.7		2.0		2.8	ns
$t_{ENZH}$	Enable-to-Pad, Z to H		2.7		3.1		3.5		4.1		5.7	ns
$t_{ENLZ}$	Enable-to-Pad, L to Z		3.0		3.5		3.9		4.6		6.4	ns
$t_{ENHZ}$	Enable-to-Pad, H to Z		3.4		3.9		4.4		5.1		7.2	ns
$d_{TLH}^3$	Delta Low to High		0.016		0.016		0.02		0.022		0.032	ns/pF
$d_{THL}^3$	Delta High to Low		0.026		0.03		0.032		0.04		0.052	ns/pF
<b>5 V TTL Output Module Timing<sup>4</sup></b>												
$t_{DLH}$	Data-to-Pad Low to High		2.4		2.8		3.1		3.7		5.1	ns
$t_{DHL}$	Data-to-Pad High to Low		3.1		3.5		4.0		4.7		6.6	ns
$t_{DHLs}$	Data-to-Pad High to Low—low slew		7.4		8.5		9.7		11.4		15.9	ns
$t_{ENZL}$	Enable-to-Pad, Z to L		2.1		2.4		2.7		3.2		4.5	ns
$t_{ENZLS}$	Enable-to-Pad, Z to L—low slew		7.4		8.4		9.5		11.0		15.4	ns
$t_{ENZH}$	Enable-to-Pad, Z to H		2.4		2.8		3.1		3.7		5.1	ns
$t_{ENLZ}$	Enable-to-Pad, L to Z		3.6		4.2		4.7		5.6		7.8	ns
$t_{ENHZ}$	Enable-to-Pad, H to Z		3.1		3.5		4.0		4.7		6.6	ns
$d_{TLH}^3$	Delta Low to High		0.014		0.017		0.017		0.023		0.031	ns/pF
$d_{THL}^3$	Delta High to Low		0.023		0.029		0.031		0.037		0.051	ns/pF
$d_{THLS}^3$	Delta High to Low—low slew		0.043		0.046		0.057		0.066		0.089	ns/pF

**Notes:**

1. All -3 speed grades have been discontinued.
2. Delays based on 50 pF loading.
3. To obtain the slew rate, substitute the appropriate Delta value, load capacitance, and the  $V_{CCI}$  value into the following equation:  

$$\text{Slew Rate [V/ns]} = (0.1 * V_{CCI} - 0.9 * V_{CCI}) / (C_{load} * d_{T[LH|HL|HLS]})$$
 where  $C_{load}$  is the load capacitance driven by the I/O in pF  
 $d_{T[LH|HL|HLS]}$  is the worst case delta value from the datasheet in ns/pF.
4. Delays based on 35 pF loading.

---

# Package Pin Assignments

---

## 208-Pin PQFP

---



Figure 3-1 • 208-Pin PQFP (Top View)

### Note

For Package Manufacturing and Environmental information, visit Resource center at <http://www.actel.com/products/rescenter/package/index.html>.

208-Pin PQFP				
Pin Number	A54SX08A Function	A54SX16A Function	A54SX32A Function	A54SX72A Function
1	GND	GND	GND	GND
2	TDI, I/O	TDI, I/O	TDI, I/O	TDI, I/O
3	I/O	I/O	I/O	I/O
4	NC	I/O	I/O	I/O
5	I/O	I/O	I/O	I/O
6	NC	I/O	I/O	I/O
7	I/O	I/O	I/O	I/O
8	I/O	I/O	I/O	I/O
9	I/O	I/O	I/O	I/O
10	I/O	I/O	I/O	I/O
11	TMS	TMS	TMS	TMS
12	V <sub>CCI</sub>	V <sub>CCI</sub>	V <sub>CCI</sub>	V <sub>CCI</sub>
13	I/O	I/O	I/O	I/O
14	NC	I/O	I/O	I/O
15	I/O	I/O	I/O	I/O
16	I/O	I/O	I/O	I/O
17	NC	I/O	I/O	I/O
18	I/O	I/O	I/O	GND
19	I/O	I/O	I/O	V <sub>CCA</sub>
20	NC	I/O	I/O	I/O
21	I/O	I/O	I/O	I/O
22	I/O	I/O	I/O	I/O
23	NC	I/O	I/O	I/O
24	I/O	I/O	I/O	I/O
25	NC	NC	NC	I/O
26	GND	GND	GND	GND
27	V <sub>CCA</sub>	V <sub>CCA</sub>	V <sub>CCA</sub>	V <sub>CCA</sub>
28	GND	GND	GND	GND
29	I/O	I/O	I/O	I/O
30	TRST, I/O	TRST, I/O	TRST, I/O	TRST, I/O
31	NC	I/O	I/O	I/O
32	I/O	I/O	I/O	I/O
33	I/O	I/O	I/O	I/O
34	I/O	I/O	I/O	I/O
35	NC	I/O	I/O	I/O

208-Pin PQFP				
Pin Number	A54SX08A Function	A54SX16A Function	A54SX32A Function	A54SX72A Function
36	I/O	I/O	I/O	I/O
37	I/O	I/O	I/O	I/O
38	I/O	I/O	I/O	I/O
39	NC	I/O	I/O	I/O
40	V <sub>CCI</sub>	V <sub>CCI</sub>	V <sub>CCI</sub>	V <sub>CCI</sub>
41	V <sub>CCA</sub>	V <sub>CCA</sub>	V <sub>CCA</sub>	V <sub>CCA</sub>
42	I/O	I/O	I/O	I/O
43	I/O	I/O	I/O	I/O
44	I/O	I/O	I/O	I/O
45	I/O	I/O	I/O	I/O
46	I/O	I/O	I/O	I/O
47	I/O	I/O	I/O	I/O
48	NC	I/O	I/O	I/O
49	I/O	I/O	I/O	I/O
50	NC	I/O	I/O	I/O
51	I/O	I/O	I/O	I/O
52	GND	GND	GND	GND
53	I/O	I/O	I/O	I/O
54	I/O	I/O	I/O	I/O
55	I/O	I/O	I/O	I/O
56	I/O	I/O	I/O	I/O
57	I/O	I/O	I/O	I/O
58	I/O	I/O	I/O	I/O
59	I/O	I/O	I/O	I/O
60	V <sub>CCI</sub>	V <sub>CCI</sub>	V <sub>CCI</sub>	V <sub>CCI</sub>
61	NC	I/O	I/O	I/O
62	I/O	I/O	I/O	I/O
63	I/O	I/O	I/O	I/O
64	NC	I/O	I/O	I/O
65	I/O	I/O	NC	I/O
66	I/O	I/O	I/O	I/O
67	NC	I/O	I/O	I/O
68	I/O	I/O	I/O	I/O
69	I/O	I/O	I/O	I/O
70	NC	I/O	I/O	I/O

208-Pin PQFP				
Pin Number	A54SX08A Function	A54SX16A Function	A54SX32A Function	A54SX72A Function
71	I/O	I/O	I/O	I/O
72	I/O	I/O	I/O	I/O
73	NC	I/O	I/O	I/O
74	I/O	I/O	I/O	QCLKA
75	NC	I/O	I/O	I/O
76	PRB, I/O	PRB, I/O	PRB, I/O	PRB, I/O
77	GND	GND	GND	GND
78	V <sub>CCA</sub>	V <sub>CCA</sub>	V <sub>CCA</sub>	V <sub>CCA</sub>
79	GND	GND	GND	GND
80	NC	NC	NC	NC
81	I/O	I/O	I/O	I/O
82	HCLK	HCLK	HCLK	HCLK
83	I/O	I/O	I/O	V <sub>CCI</sub>
84	I/O	I/O	I/O	QCLKB
85	NC	I/O	I/O	I/O
86	I/O	I/O	I/O	I/O
87	I/O	I/O	I/O	I/O
88	NC	I/O	I/O	I/O
89	I/O	I/O	I/O	I/O
90	I/O	I/O	I/O	I/O
91	NC	I/O	I/O	I/O
92	I/O	I/O	I/O	I/O
93	I/O	I/O	I/O	I/O
94	NC	I/O	I/O	I/O
95	I/O	I/O	I/O	I/O
96	I/O	I/O	I/O	I/O
97	NC	I/O	I/O	I/O
98	V <sub>CCI</sub>	V <sub>CCI</sub>	V <sub>CCI</sub>	V <sub>CCI</sub>
99	I/O	I/O	I/O	I/O
100	I/O	I/O	I/O	I/O
101	I/O	I/O	I/O	I/O
102	I/O	I/O	I/O	I/O
103	TDO, I/O	TDO, I/O	TDO, I/O	TDO, I/O
104	I/O	I/O	I/O	I/O
105	GND	GND	GND	GND

208-Pin PQFP				
Pin Number	A54SX08A Function	A54SX16A Function	A54SX32A Function	A54SX72A Function
106	NC	I/O	I/O	I/O
107	I/O	I/O	I/O	I/O
108	NC	I/O	I/O	I/O
109	I/O	I/O	I/O	I/O
110	I/O	I/O	I/O	I/O
111	I/O	I/O	I/O	I/O
112	I/O	I/O	I/O	I/O
113	I/O	I/O	I/O	I/O
114	V <sub>CCA</sub>	V <sub>CCA</sub>	V <sub>CCA</sub>	V <sub>CCA</sub>
115	V <sub>CCI</sub>	V <sub>CCI</sub>	V <sub>CCI</sub>	V <sub>CCI</sub>
116	NC	I/O	I/O	GND
117	I/O	I/O	I/O	V <sub>CCA</sub>
118	I/O	I/O	I/O	I/O
119	NC	I/O	I/O	I/O
120	I/O	I/O	I/O	I/O
121	I/O	I/O	I/O	I/O
122	NC	I/O	I/O	I/O
123	I/O	I/O	I/O	I/O
124	I/O	I/O	I/O	I/O
125	NC	I/O	I/O	I/O
126	I/O	I/O	I/O	I/O
127	I/O	I/O	I/O	I/O
128	I/O	I/O	I/O	I/O
129	GND	GND	GND	GND
130	V <sub>CCA</sub>	V <sub>CCA</sub>	V <sub>CCA</sub>	V <sub>CCA</sub>
131	GND	GND	GND	GND
132	NC	NC	NC	I/O
133	I/O	I/O	I/O	I/O
134	I/O	I/O	I/O	I/O
135	NC	I/O	I/O	I/O
136	I/O	I/O	I/O	I/O
137	I/O	I/O	I/O	I/O
138	NC	I/O	I/O	I/O
139	I/O	I/O	I/O	I/O
140	I/O	I/O	I/O	I/O

208-Pin PQFP				
Pin Number	A54SX08A Function	A54SX16A Function	A54SX32A Function	A54SX72A Function
141	NC	I/O	I/O	I/O
142	I/O	I/O	I/O	I/O
143	NC	I/O	I/O	I/O
144	I/O	I/O	I/O	I/O
145	V <sub>CCA</sub>	V <sub>CCA</sub>	V <sub>CCA</sub>	V <sub>CCA</sub>
146	GND	GND	GND	GND
147	I/O	I/O	I/O	I/O
148	V <sub>CCI</sub>	V <sub>CCI</sub>	V <sub>CCI</sub>	V <sub>CCI</sub>
149	I/O	I/O	I/O	I/O
150	I/O	I/O	I/O	I/O
151	I/O	I/O	I/O	I/O
152	I/O	I/O	I/O	I/O
153	I/O	I/O	I/O	I/O
154	I/O	I/O	I/O	I/O
155	NC	I/O	I/O	I/O
156	NC	I/O	I/O	I/O
157	GND	GND	GND	GND
158	I/O	I/O	I/O	I/O
159	I/O	I/O	I/O	I/O
160	I/O	I/O	I/O	I/O
161	I/O	I/O	I/O	I/O
162	I/O	I/O	I/O	I/O
163	I/O	I/O	I/O	I/O
164	V <sub>CCI</sub>	V <sub>CCI</sub>	V <sub>CCI</sub>	V <sub>CCI</sub>
165	I/O	I/O	I/O	I/O
166	I/O	I/O	I/O	I/O
167	NC	I/O	I/O	I/O
168	I/O	I/O	I/O	I/O
169	I/O	I/O	I/O	I/O
170	NC	I/O	I/O	I/O
171	I/O	I/O	I/O	I/O
172	I/O	I/O	I/O	I/O
173	NC	I/O	I/O	I/O
174	I/O	I/O	I/O	I/O
175	I/O	I/O	I/O	I/O

208-Pin PQFP				
Pin Number	A54SX08A Function	A54SX16A Function	A54SX32A Function	A54SX72A Function
176	NC	I/O	I/O	I/O
177	I/O	I/O	I/O	I/O
178	I/O	I/O	I/O	QCLKD
179	I/O	I/O	I/O	I/O
180	CLKA	CLKA	CLKA	CLKA
181	CLKB	CLKB	CLKB	CLKB
182	NC	NC	NC	NC
183	GND	GND	GND	GND
184	V <sub>CCA</sub>	V <sub>CCA</sub>	V <sub>CCA</sub>	V <sub>CCA</sub>
185	GND	GND	GND	GND
186	PRA, I/O	PRA, I/O	PRA, I/O	PRA, I/O
187	I/O	I/O	I/O	V <sub>CCI</sub>
188	I/O	I/O	I/O	I/O
189	NC	I/O	I/O	I/O
190	I/O	I/O	I/O	QCLKC
191	I/O	I/O	I/O	I/O
192	NC	I/O	I/O	I/O
193	I/O	I/O	I/O	I/O
194	I/O	I/O	I/O	I/O
195	NC	I/O	I/O	I/O
196	I/O	I/O	I/O	I/O
197	I/O	I/O	I/O	I/O
198	NC	I/O	I/O	I/O
199	I/O	I/O	I/O	I/O
200	I/O	I/O	I/O	I/O
201	V <sub>CCI</sub>	V <sub>CCI</sub>	V <sub>CCI</sub>	V <sub>CCI</sub>
202	NC	I/O	I/O	I/O
203	NC	I/O	I/O	I/O
204	I/O	I/O	I/O	I/O
205	NC	I/O	I/O	I/O
206	I/O	I/O	I/O	I/O
207	I/O	I/O	I/O	I/O
208	TCK, I/O	TCK, I/O	TCK, I/O	TCK, I/O

## 100-Pin TQFP



Figure 3-2 • 100-Pin TQFP

### Note

For Package Manufacturing and Environmental information, visit Resource center at <http://www.actel.com/products/rescenter/package/index.html>.

100-TQFP			
Pin Number	A54SX08A Function	A54SX16A Function	A54SX32A Function
1	GND	GND	GND
2	TDI, I/O	TDI, I/O	TDI, I/O
3	I/O	I/O	I/O
4	I/O	I/O	I/O
5	I/O	I/O	I/O
6	I/O	I/O	I/O
7	TMS	TMS	TMS
8	V <sub>CCI</sub>	V <sub>CCI</sub>	V <sub>CCI</sub>
9	GND	GND	GND
10	I/O	I/O	I/O
11	I/O	I/O	I/O
12	I/O	I/O	I/O
13	I/O	I/O	I/O
14	I/O	I/O	I/O
15	I/O	I/O	I/O
16	TRST, I/O	TRST, I/O	TRST, I/O
17	I/O	I/O	I/O
18	I/O	I/O	I/O
19	I/O	I/O	I/O
20	V <sub>CCI</sub>	V <sub>CCI</sub>	V <sub>CCI</sub>
21	I/O	I/O	I/O
22	I/O	I/O	I/O
23	I/O	I/O	I/O
24	I/O	I/O	I/O
25	I/O	I/O	I/O
26	I/O	I/O	I/O
27	I/O	I/O	I/O
28	I/O	I/O	I/O
29	I/O	I/O	I/O
30	I/O	I/O	I/O
31	I/O	I/O	I/O
32	I/O	I/O	I/O
33	I/O	I/O	I/O
34	PRB, I/O	PRB, I/O	PRB, I/O
35	V <sub>CCA</sub>	V <sub>CCA</sub>	V <sub>CCA</sub>

100-TQFP			
Pin Number	A54SX08A Function	A54SX16A Function	A54SX32A Function
36	GND	GND	GND
37	NC	NC	NC
38	I/O	I/O	I/O
39	HCLK	HCLK	HCLK
40	I/O	I/O	I/O
41	I/O	I/O	I/O
42	I/O	I/O	I/O
43	I/O	I/O	I/O
44	V <sub>CCI</sub>	V <sub>CCI</sub>	V <sub>CCI</sub>
45	I/O	I/O	I/O
46	I/O	I/O	I/O
47	I/O	I/O	I/O
48	I/O	I/O	I/O
49	TDO, I/O	TDO, I/O	TDO, I/O
50	I/O	I/O	I/O
51	GND	GND	GND
52	I/O	I/O	I/O
53	I/O	I/O	I/O
54	I/O	I/O	I/O
55	I/O	I/O	I/O
56	I/O	I/O	I/O
57	V <sub>CCA</sub>	V <sub>CCA</sub>	V <sub>CCA</sub>
58	V <sub>CCI</sub>	V <sub>CCI</sub>	V <sub>CCI</sub>
59	I/O	I/O	I/O
60	I/O	I/O	I/O
61	I/O	I/O	I/O
62	I/O	I/O	I/O
63	I/O	I/O	I/O
64	I/O	I/O	I/O
65	I/O	I/O	I/O
66	I/O	I/O	I/O
67	V <sub>CCA</sub>	V <sub>CCA</sub>	V <sub>CCA</sub>
68	GND	GND	GND
69	GND	GND	GND
70	I/O	I/O	I/O

100-TQFP			
Pin Number	A54SX08A Function	A54SX16A Function	A54SX32A Function
71	I/O	I/O	I/O
72	I/O	I/O	I/O
73	I/O	I/O	I/O
74	I/O	I/O	I/O
75	I/O	I/O	I/O
76	I/O	I/O	I/O
77	I/O	I/O	I/O
78	I/O	I/O	I/O
79	I/O	I/O	I/O
80	I/O	I/O	I/O
81	I/O	I/O	I/O
82	V <sub>CCI</sub>	V <sub>CCI</sub>	V <sub>CCI</sub>
83	I/O	I/O	I/O
84	I/O	I/O	I/O
85	I/O	I/O	I/O
86	I/O	I/O	I/O
87	CLKA	CLKA	CLKA
88	CLKB	CLKB	CLKB
89	NC	NC	NC
90	V <sub>CCA</sub>	V <sub>CCA</sub>	V <sub>CCA</sub>
91	GND	GND	GND
92	PRA, I/O	PRA, I/O	PRA, I/O
93	I/O	I/O	I/O
94	I/O	I/O	I/O
95	I/O	I/O	I/O
96	I/O	I/O	I/O
97	I/O	I/O	I/O
98	I/O	I/O	I/O
99	I/O	I/O	I/O
100	TCK, I/O	TCK, I/O	TCK, I/O

## 144-Pin TQFP



Figure 3-3 • 144-Pin TQFP (Top View)

### Note

For Package Manufacturing and Environmental information, visit Resource center at <http://www.actel.com/products/rescenter/package/index.html>.

144-Pin TQFP			
Pin Number	A54SX08A Function	A54SX16A Function	A54SX32A Function
1	GND	GND	GND
2	TDI, I/O	TDI, I/O	TDI, I/O
3	I/O	I/O	I/O
4	I/O	I/O	I/O
5	I/O	I/O	I/O
6	I/O	I/O	I/O
7	I/O	I/O	I/O
8	I/O	I/O	I/O
9	TMS	TMS	TMS
10	V <sub>CCI</sub>	V <sub>CCI</sub>	V <sub>CCI</sub>
11	GND	GND	GND
12	I/O	I/O	I/O
13	I/O	I/O	I/O
14	I/O	I/O	I/O
15	I/O	I/O	I/O
16	I/O	I/O	I/O
17	I/O	I/O	I/O
18	I/O	I/O	I/O
19	NC	NC	NC
20	V <sub>CCA</sub>	V <sub>CCA</sub>	V <sub>CCA</sub>
21	I/O	I/O	I/O
22	TRST, I/O	TRST, I/O	TRST, I/O
23	I/O	I/O	I/O
24	I/O	I/O	I/O
25	I/O	I/O	I/O
26	I/O	I/O	I/O
27	I/O	I/O	I/O
28	GND	GND	GND
29	V <sub>CCI</sub>	V <sub>CCI</sub>	V <sub>CCI</sub>
30	V <sub>CCA</sub>	V <sub>CCA</sub>	V <sub>CCA</sub>
31	I/O	I/O	I/O
32	I/O	I/O	I/O
33	I/O	I/O	I/O
34	I/O	I/O	I/O
35	I/O	I/O	I/O
36	GND	GND	GND
37	I/O	I/O	I/O

144-Pin TQFP			
Pin Number	A54SX08A Function	A54SX16A Function	A54SX32A Function
38	I/O	I/O	I/O
39	I/O	I/O	I/O
40	I/O	I/O	I/O
41	I/O	I/O	I/O
42	I/O	I/O	I/O
43	I/O	I/O	I/O
44	V <sub>CCI</sub>	V <sub>CCI</sub>	V <sub>CCI</sub>
45	I/O	I/O	I/O
46	I/O	I/O	I/O
47	I/O	I/O	I/O
48	I/O	I/O	I/O
49	I/O	I/O	I/O
50	I/O	I/O	I/O
51	I/O	I/O	I/O
52	I/O	I/O	I/O
53	I/O	I/O	I/O
54	PRB, I/O	PRB, I/O	PRB, I/O
55	I/O	I/O	I/O
56	V <sub>CCA</sub>	V <sub>CCA</sub>	V <sub>CCA</sub>
57	GND	GND	GND
58	NC	NC	NC
59	I/O	I/O	I/O
60	HCLK	HCLK	HCLK
61	I/O	I/O	I/O
62	I/O	I/O	I/O
63	I/O	I/O	I/O
64	I/O	I/O	I/O
65	I/O	I/O	I/O
66	I/O	I/O	I/O
67	I/O	I/O	I/O
68	V <sub>CCI</sub>	V <sub>CCI</sub>	V <sub>CCI</sub>
69	I/O	I/O	I/O
70	I/O	I/O	I/O
71	TDO, I/O	TDO, I/O	TDO, I/O
72	I/O	I/O	I/O
73	GND	GND	GND
74	I/O	I/O	I/O

144-Pin TQFP			
Pin Number	A54SX08A Function	A54SX16A Function	A54SX32A Function
75	I/O	I/O	I/O
76	I/O	I/O	I/O
77	I/O	I/O	I/O
78	I/O	I/O	I/O
79	V <sub>CCA</sub>	V <sub>CCA</sub>	V <sub>CCA</sub>
80	V <sub>CCI</sub>	V <sub>CCI</sub>	V <sub>CCI</sub>
81	GND	GND	GND
82	I/O	I/O	I/O
83	I/O	I/O	I/O
84	I/O	I/O	I/O
85	I/O	I/O	I/O
86	I/O	I/O	I/O
87	I/O	I/O	I/O
88	I/O	I/O	I/O
89	V <sub>CCA</sub>	V <sub>CCA</sub>	V <sub>CCA</sub>
90	NC	NC	NC
91	I/O	I/O	I/O
92	I/O	I/O	I/O
93	I/O	I/O	I/O
94	I/O	I/O	I/O
95	I/O	I/O	I/O
96	I/O	I/O	I/O
97	I/O	I/O	I/O
98	V <sub>CCA</sub>	V <sub>CCA</sub>	V <sub>CCA</sub>
99	GND	GND	GND
100	I/O	I/O	I/O
101	GND	GND	GND
102	V <sub>CCI</sub>	V <sub>CCI</sub>	V <sub>CCI</sub>
103	I/O	I/O	I/O
104	I/O	I/O	I/O
105	I/O	I/O	I/O
106	I/O	I/O	I/O
107	I/O	I/O	I/O
108	I/O	I/O	I/O
109	GND	GND	GND
110	I/O	I/O	I/O

144-Pin TQFP			
Pin Number	A54SX08A Function	A54SX16A Function	A54SX32A Function
111	I/O	I/O	I/O
112	I/O	I/O	I/O
113	I/O	I/O	I/O
114	I/O	I/O	I/O
115	V <sub>CCI</sub>	V <sub>CCI</sub>	V <sub>CCI</sub>
116	I/O	I/O	I/O
117	I/O	I/O	I/O
118	I/O	I/O	I/O
119	I/O	I/O	I/O
120	I/O	I/O	I/O
121	I/O	I/O	I/O
122	I/O	I/O	I/O
123	I/O	I/O	I/O
124	I/O	I/O	I/O
125	CLKA	CLKA	CLKA
126	CLKB	CLKB	CLKB
127	NC	NC	NC
128	GND	GND	GND
129	V <sub>CCA</sub>	V <sub>CCA</sub>	V <sub>CCA</sub>
130	I/O	I/O	I/O
131	PRA, I/O	PRA, I/O	PRA, I/O
132	I/O	I/O	I/O
133	I/O	I/O	I/O
134	I/O	I/O	I/O
135	I/O	I/O	I/O
136	I/O	I/O	I/O
137	I/O	I/O	I/O
138	I/O	I/O	I/O
139	I/O	I/O	I/O
140	V <sub>CCI</sub>	V <sub>CCI</sub>	V <sub>CCI</sub>
141	I/O	I/O	I/O
142	I/O	I/O	I/O
143	I/O	I/O	I/O
144	TCK, I/O	TCK, I/O	TCK, I/O

## 176-Pin TQFP

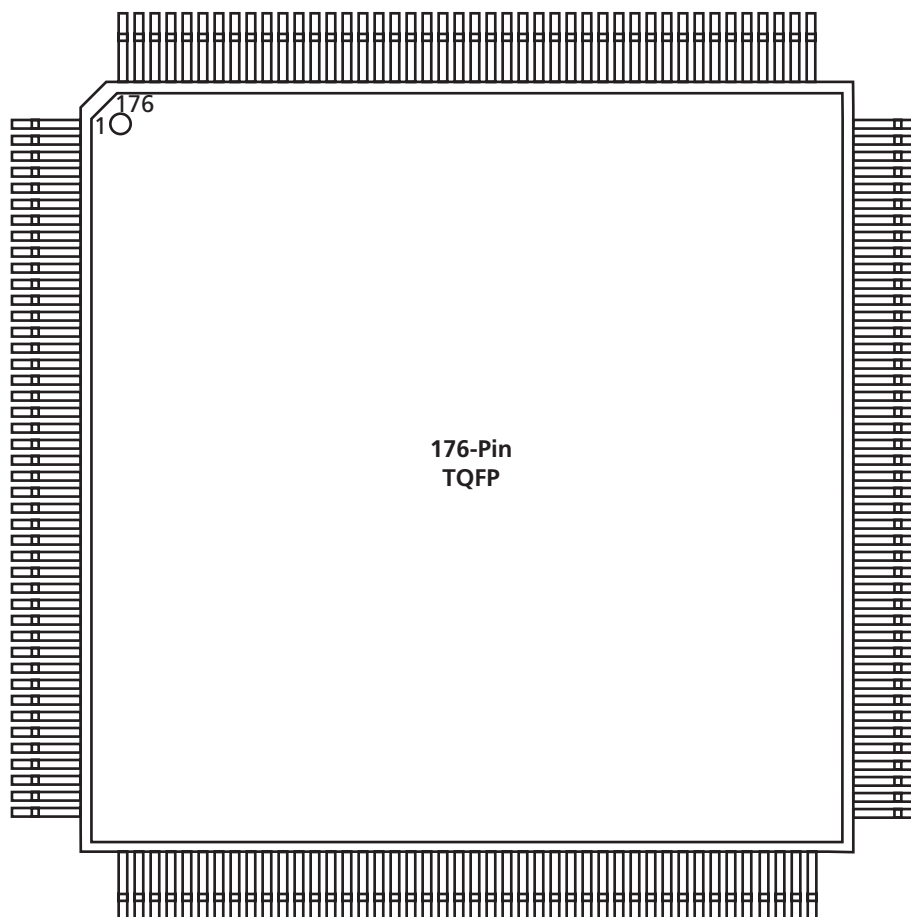

Figure 3-4 • 176-Pin TQFP (Top View)

### Note

For Package Manufacturing and Environmental information, visit Resource center at <http://www.actel.com/products/rescenter/package/index.html>.

176-Pin TQFP	
Pin Number	A54SX32A Function
1	GND
2	TDI, I/O
3	I/O
4	I/O
5	I/O
6	I/O
7	I/O
8	I/O
9	I/O
10	TMS
11	V <sub>CCI</sub>
12	I/O
13	I/O
14	I/O
15	I/O
16	I/O
17	I/O
18	I/O
19	I/O
20	I/O
21	GND
22	V <sub>CCA</sub>
23	GND
24	I/O
25	TRST, I/O
26	I/O
27	I/O
28	I/O
29	I/O
30	I/O
31	I/O
32	V <sub>CCI</sub>
33	V <sub>CCA</sub>
34	I/O
35	I/O
36	I/O

176-Pin TQFP	
Pin Number	A54SX32A Function
37	I/O
38	I/O
39	I/O
40	I/O
41	I/O
42	I/O
43	I/O
44	GND
45	I/O
46	I/O
47	I/O
48	I/O
49	I/O
50	I/O
51	I/O
52	V <sub>CCI</sub>
53	I/O
54	I/O
55	I/O
56	I/O
57	I/O
58	I/O
59	I/O
60	I/O
61	I/O
62	I/O
63	I/O
64	PRB, I/O
65	GND
66	V <sub>CCA</sub>
67	NC
68	I/O
69	HCLK
70	I/O
71	I/O
72	I/O

176-Pin TQFP	
Pin Number	A54SX32A Function
73	I/O
74	I/O
75	I/O
76	I/O
77	I/O
78	I/O
79	I/O
80	I/O
81	I/O
82	V <sub>CCI</sub>
83	I/O
84	I/O
85	I/O
86	I/O
87	TDO, I/O
88	I/O
89	GND
90	I/O
91	I/O
92	I/O
93	I/O
94	I/O
95	I/O
96	I/O
97	I/O
98	V <sub>CCA</sub>
99	V <sub>CCI</sub>
100	I/O
101	I/O
102	I/O
103	I/O
104	I/O
105	I/O
106	I/O
107	I/O
108	GND

176-Pin TQFP	
Pin Number	A54SX32A Function
109	V <sub>CCA</sub>
110	GND
111	I/O
112	I/O
113	I/O
114	I/O
115	I/O
116	I/O
117	I/O
118	I/O
119	I/O
120	I/O
121	I/O
122	V <sub>CCA</sub>
123	GND
124	V <sub>CCI</sub>
125	I/O
126	I/O
127	I/O
128	I/O
129	I/O
130	I/O
131	I/O
132	I/O
133	GND
134	I/O
135	I/O
136	I/O
137	I/O
138	I/O
139	I/O
140	V <sub>CCI</sub>
141	I/O
142	I/O
143	I/O
144	I/O

176-Pin TQFP	
Pin Number	A54SX32A Function
145	I/O
146	I/O
147	I/O
148	I/O
149	I/O
150	I/O
151	I/O
152	CLKA
153	CLKB
154	NC
155	GND
156	V <sub>CCA</sub>
157	PRA, I/O
158	I/O
159	I/O
160	I/O
161	I/O
162	I/O
163	I/O
164	I/O
165	I/O
166	I/O
167	I/O
168	I/O
169	V <sub>CCI</sub>
170	I/O
171	I/O
172	I/O
173	I/O
174	I/O
175	I/O
176	TCK, I/O

# 329-Pin PBGA

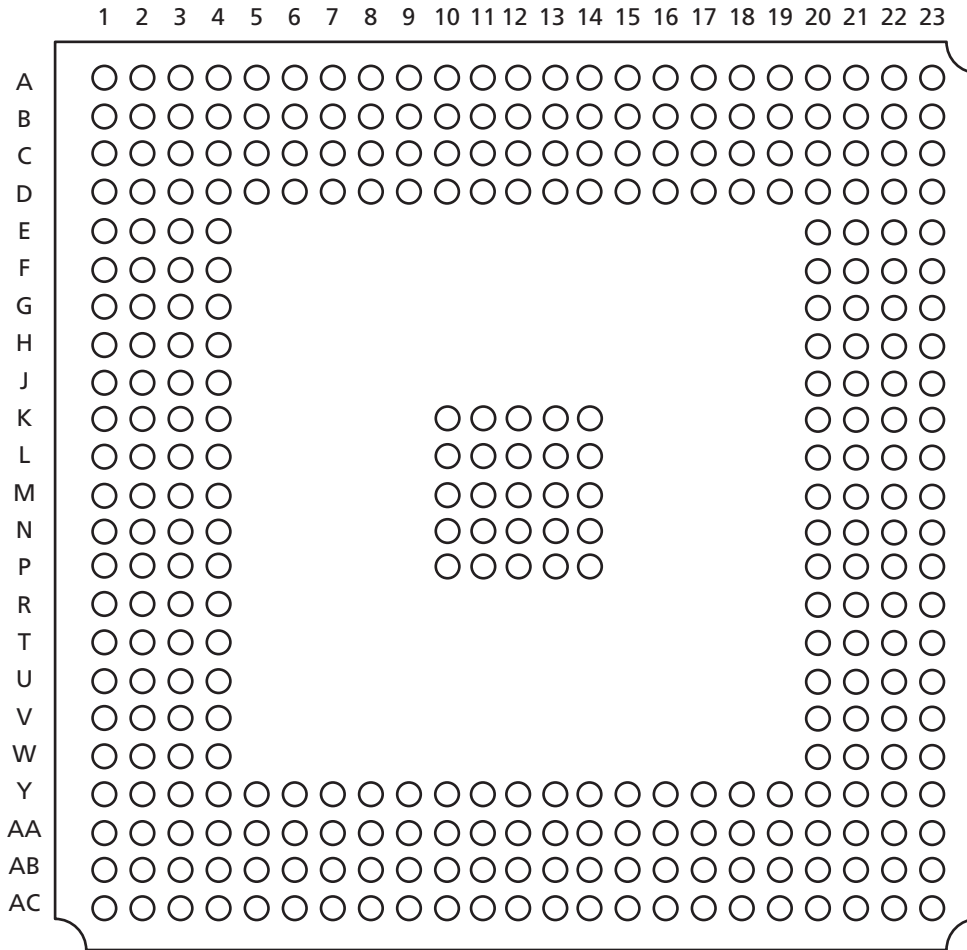

Figure 3-5 • 329-Pin PBGA (Top View)

### Note

For Package Manufacturing and Environmental information, visit Resource center at <http://www.actel.com/products/rescenter/package/index.html>.

329-Pin PBGA	
Pin Number	A54SX32A Function
A1	GND
A2	GND
A3	V <sub>CCI</sub>
A4	NC
A5	I/O
A6	I/O
A7	V <sub>CCI</sub>
A8	NC
A9	I/O
A10	I/O
A11	I/O
A12	I/O
A13	CLKB
A14	I/O
A15	I/O
A16	I/O
A17	I/O
A18	I/O
A19	I/O
A20	I/O
A21	NC
A22	V <sub>CCI</sub>
A23	GND
AA1	V <sub>CCI</sub>
AA2	I/O
AA3	GND
AA4	I/O
AA5	I/O
AA6	I/O
AA7	I/O
AA8	I/O
AA9	I/O
AA10	I/O
AA11	I/O
AA12	I/O
AA13	I/O
AA14	I/O

329-Pin PBGA	
Pin Number	A54SX32A Function
AA15	I/O
AA16	I/O
AA17	I/O
AA18	I/O
AA19	I/O
AA20	TDO, I/O
AA21	V <sub>CCI</sub>
AA22	I/O
AA23	V <sub>CCI</sub>
AB1	I/O
AB2	GND
AB3	I/O
AB4	I/O
AB5	I/O
AB6	I/O
AB7	I/O
AB8	I/O
AB9	I/O
AB10	I/O
AB11	PRB, I/O
AB12	I/O
AB13	HCLK
AB14	I/O
AB15	I/O
AB16	I/O
AB17	I/O
AB18	I/O
AB19	I/O
AB20	I/O
AB21	I/O
AB22	GND
AB23	I/O
AC1	GND
AC2	V <sub>CCI</sub>
AC3	NC
AC4	I/O
AC5	I/O

329-Pin PBGA	
Pin Number	A54SX32A Function
AC6	I/O
AC7	I/O
AC8	I/O
AC9	V <sub>CCI</sub>
AC10	I/O
AC11	I/O
AC12	I/O
AC13	I/O
AC14	I/O
AC15	NC
AC16	I/O
AC17	I/O
AC18	I/O
AC19	I/O
AC20	I/O
AC21	NC
AC22	V <sub>CCI</sub>
AC23	GND
B1	V <sub>CCI</sub>
B2	GND
B3	I/O
B4	I/O
B5	I/O
B6	I/O
B7	I/O
B8	I/O
B9	I/O
B10	I/O
B11	I/O
B12	PRA, I/O
B13	CLKA
B14	I/O
B15	I/O
B16	I/O
B17	I/O
B18	I/O
B19	I/O

329-Pin PBGA	
Pin Number	A54SX32A Function
B20	I/O
B21	I/O
B22	GND
B23	V <sub>CCI</sub>
C1	NC
C2	TDI, I/O
C3	GND
C4	I/O
C5	I/O
C6	I/O
C7	I/O
C8	I/O
C9	I/O
C10	I/O
C11	I/O
C12	I/O
C13	I/O
C14	I/O
C15	I/O
C16	I/O
C17	I/O
C18	I/O
C19	I/O
C20	I/O
C21	V <sub>CCI</sub>
C22	GND
C23	NC
D1	I/O
D2	I/O
D3	I/O
D4	TCK, I/O
D5	I/O
D6	I/O
D7	I/O
D8	I/O
D9	I/O
D10	I/O

329-Pin PBGA	
Pin Number	A54SX32A Function
D11	V <sub>CCA</sub>
D12	NC
D13	I/O
D14	I/O
D15	I/O
D16	I/O
D17	I/O
D18	I/O
D19	I/O
D20	I/O
D21	I/O
D22	I/O
D23	I/O
E1	V <sub>CCI</sub>
E2	I/O
E3	I/O
E4	I/O
E20	I/O
E21	I/O
E22	I/O
E23	I/O
F1	I/O
F2	TMS
F3	I/O
F4	I/O
F20	I/O
F21	I/O
F22	I/O
F23	I/O
G1	I/O
G2	I/O
G3	I/O
G4	I/O
G20	I/O
G21	I/O
G22	I/O
G23	GND

329-Pin PBGA	
Pin Number	A54SX32A Function
H1	I/O
H2	I/O
H3	I/O
H4	I/O
H20	V <sub>CCA</sub>
H21	I/O
H22	I/O
H23	I/O
J1	NC
J2	I/O
J3	I/O
J4	I/O
J20	I/O
J21	I/O
J22	I/O
J23	I/O
K1	I/O
K2	I/O
K3	I/O
K4	I/O
K10	GND
K11	GND
K12	GND
K13	GND
K14	GND
K20	I/O
K21	I/O
K22	I/O
K23	I/O
L1	I/O
L2	I/O
L3	I/O
L4	NC
L10	GND
L11	GND
L12	GND
L13	GND

329-Pin PBGA	
Pin Number	A54SX32A Function
L14	GND
L20	NC
L21	I/O
L22	I/O
L23	NC
M1	I/O
M2	I/O
M3	I/O
M4	V <sub>CCA</sub>
M10	GND
M11	GND
M12	GND
M13	GND
M14	GND
M20	V <sub>CCA</sub>
M21	I/O
M22	I/O
M23	V <sub>CCI</sub>
N1	I/O
N2	TRST, I/O
N3	I/O
N4	I/O
N10	GND
N11	GND
N12	GND
N13	GND
N14	GND
N20	NC
N21	I/O
N22	I/O
N23	I/O
P1	I/O
P2	I/O
P3	I/O
P4	I/O
P10	GND
P11	GND

329-Pin PBGA	
Pin Number	A54SX32A Function
P12	GND
P13	GND
P14	GND
P20	I/O
P21	I/O
P22	I/O
P23	I/O
R1	I/O
R2	I/O
R3	I/O
R4	I/O
R20	I/O
R21	I/O
R22	I/O
R23	I/O
T1	I/O
T2	I/O
T3	I/O
T4	I/O
T20	I/O
T21	I/O
T22	I/O
T23	I/O
U1	I/O
U2	I/O
U3	V <sub>CCA</sub>
U4	I/O
U20	I/O
U21	V <sub>CCA</sub>
U22	I/O
U23	I/O
V1	V <sub>CCI</sub>
V2	I/O
V3	I/O
V4	I/O
V20	I/O
V21	I/O

329-Pin PBGA	
Pin Number	A54SX32A Function
V22	I/O
V23	I/O
W1	I/O
W2	I/O
W3	I/O
W4	I/O
W20	I/O
W21	I/O
W22	I/O
W23	NC
Y1	NC
Y2	I/O
Y3	I/O
Y4	GND
Y5	I/O
Y6	I/O
Y7	I/O
Y8	I/O
Y9	I/O
Y10	I/O
Y11	I/O
Y12	V <sub>CCA</sub>
Y13	NC
Y14	I/O
Y15	I/O
Y16	I/O
Y17	I/O
Y18	I/O
Y19	I/O
Y20	GND
Y21	I/O
Y22	I/O
Y23	I/O

# 144-Pin FBGA



Figure 3-6 • 144-Pin FBGA (Top View)

### Note

For Package Manufacturing and Environmental information, visit Resource center at <http://www.actel.com/products/rescenter/package/index.html>.

144-Pin FBGA			
Pin Number	A54SX08A Function	A54SX16A Function	A54SX32A Function
A1	I/O	I/O	I/O
A2	I/O	I/O	I/O
A3	I/O	I/O	I/O
A4	I/O	I/O	I/O
A5	V <sub>CCA</sub>	V <sub>CCA</sub>	V <sub>CCA</sub>
A6	GND	GND	GND
A7	CLKA	CLKA	CLKA
A8	I/O	I/O	I/O
A9	I/O	I/O	I/O
A10	I/O	I/O	I/O
A11	I/O	I/O	I/O
A12	I/O	I/O	I/O
B1	I/O	I/O	I/O
B2	GND	GND	GND
B3	I/O	I/O	I/O
B4	I/O	I/O	I/O
B5	I/O	I/O	I/O
B6	I/O	I/O	I/O
B7	CLKB	CLKB	CLKB
B8	I/O	I/O	I/O
B9	I/O	I/O	I/O
B10	I/O	I/O	I/O
B11	GND	GND	GND
B12	I/O	I/O	I/O
C1	I/O	I/O	I/O
C2	I/O	I/O	I/O
C3	TCK, I/O	TCK, I/O	TCK, I/O
C4	I/O	I/O	I/O
C5	I/O	I/O	I/O
C6	PRA, I/O	PRA, I/O	PRA, I/O
C7	I/O	I/O	I/O
C8	I/O	I/O	I/O
C9	I/O	I/O	I/O
C10	I/O	I/O	I/O
C11	I/O	I/O	I/O
C12	I/O	I/O	I/O

144-Pin FBGA			
Pin Number	A54SX08A Function	A54SX16A Function	A54SX32A Function
D1	I/O	I/O	I/O
D2	V <sub>CCI</sub>	V <sub>CCI</sub>	V <sub>CCI</sub>
D3	TDI, I/O	TDI, I/O	TDI, I/O
D4	I/O	I/O	I/O
D5	I/O	I/O	I/O
D6	I/O	I/O	I/O
D7	I/O	I/O	I/O
D8	I/O	I/O	I/O
D9	I/O	I/O	I/O
D10	I/O	I/O	I/O
D11	I/O	I/O	I/O
D12	I/O	I/O	I/O
E1	I/O	I/O	I/O
E2	I/O	I/O	I/O
E3	I/O	I/O	I/O
E4	I/O	I/O	I/O
E5	TMS	TMS	TMS
E6	V <sub>CCI</sub>	V <sub>CCI</sub>	V <sub>CCI</sub>
E7	V <sub>CCI</sub>	V <sub>CCI</sub>	V <sub>CCI</sub>
E8	V <sub>CCI</sub>	V <sub>CCI</sub>	V <sub>CCI</sub>
E9	V <sub>CCA</sub>	V <sub>CCA</sub>	V <sub>CCA</sub>
E10	I/O	I/O	I/O
E11	GND	GND	GND
E12	I/O	I/O	I/O
F1	I/O	I/O	I/O
F2	I/O	I/O	I/O
F3	NC	NC	NC
F4	I/O	I/O	I/O
F5	GND	GND	GND
F6	GND	GND	GND
F7	GND	GND	GND
F8	V <sub>CCI</sub>	V <sub>CCI</sub>	V <sub>CCI</sub>
F9	I/O	I/O	I/O
F10	GND	GND	GND
F11	I/O	I/O	I/O
F12	I/O	I/O	I/O

144-Pin FBGA			
Pin Number	A54SX08A Function	A54SX16A Function	A54SX32A Function
G1	I/O	I/O	I/O
G2	GND	GND	GND
G3	I/O	I/O	I/O
G4	I/O	I/O	I/O
G5	GND	GND	GND
G6	GND	GND	GND
G7	GND	GND	GND
G8	V <sub>CCI</sub>	V <sub>CCI</sub>	V <sub>CCI</sub>
G9	I/O	I/O	I/O
G10	I/O	I/O	I/O
G11	I/O	I/O	I/O
G12	I/O	I/O	I/O
H1	TRST, I/O	TRST, I/O	TRST, I/O
H2	I/O	I/O	I/O
H3	I/O	I/O	I/O
H4	I/O	I/O	I/O
H5	V <sub>CCA</sub>	V <sub>CCA</sub>	V <sub>CCA</sub>
H6	V <sub>CCA</sub>	V <sub>CCA</sub>	V <sub>CCA</sub>
H7	V <sub>CCI</sub>	V <sub>CCI</sub>	V <sub>CCI</sub>
H8	V <sub>CCI</sub>	V <sub>CCI</sub>	V <sub>CCI</sub>
H9	V <sub>CCA</sub>	V <sub>CCA</sub>	V <sub>CCA</sub>
H10	I/O	I/O	I/O
H11	I/O	I/O	I/O
H12	NC	NC	NC
J1	I/O	I/O	I/O
J2	I/O	I/O	I/O
J3	I/O	I/O	I/O
J4	I/O	I/O	I/O
J5	I/O	I/O	I/O
J6	PRB, I/O	PRB, I/O	PRB, I/O
J7	I/O	I/O	I/O
J8	I/O	I/O	I/O
J9	I/O	I/O	I/O
J10	I/O	I/O	I/O
J11	I/O	I/O	I/O
J12	V <sub>CCA</sub>	V <sub>CCA</sub>	V <sub>CCA</sub>

144-Pin FBGA			
Pin Number	A54SX08A Function	A54SX16A Function	A54SX32A Function
K1	I/O	I/O	I/O
K2	I/O	I/O	I/O
K3	I/O	I/O	I/O
K4	I/O	I/O	I/O
K5	I/O	I/O	I/O
K6	I/O	I/O	I/O
K7	GND	GND	GND
K8	I/O	I/O	I/O
K9	I/O	I/O	I/O
K10	GND	GND	GND
K11	I/O	I/O	I/O
K12	I/O	I/O	I/O
L1	GND	GND	GND
L2	I/O	I/O	I/O
L3	I/O	I/O	I/O
L4	I/O	I/O	I/O
L5	I/O	I/O	I/O
L6	I/O	I/O	I/O
L7	HCLK	HCLK	HCLK
L8	I/O	I/O	I/O
L9	I/O	I/O	I/O
L10	I/O	I/O	I/O
L11	I/O	I/O	I/O
L12	I/O	I/O	I/O
M1	I/O	I/O	I/O
M2	I/O	I/O	I/O
M3	I/O	I/O	I/O
M4	I/O	I/O	I/O
M5	I/O	I/O	I/O
M6	I/O	I/O	I/O
M7	V <sub>CCA</sub>	V <sub>CCA</sub>	V <sub>CCA</sub>
M8	I/O	I/O	I/O
M9	I/O	I/O	I/O
M10	I/O	I/O	I/O
M11	TDO, I/O	TDO, I/O	TDO, I/O
M12	I/O	I/O	I/O

## 256-Pin FBGA



Figure 3-7 • 256-Pin FBGA (Top View)

### Note

For Package Manufacturing and Environmental information, visit Resource center at <http://www.actel.com/products/rescenter/package/index.html>.

256-Pin FBGA			
Pin Number	A54SX16A Function	A54SX32A Function	A54SX72A Function
A1	GND	GND	GND
A2	TCK, I/O	TCK, I/O	TCK, I/O
A3	I/O	I/O	I/O
A4	I/O	I/O	I/O
A5	I/O	I/O	I/O
A6	I/O	I/O	I/O
A7	I/O	I/O	I/O
A8	I/O	I/O	I/O
A9	CLKB	CLKB	CLKB
A10	I/O	I/O	I/O
A11	I/O	I/O	I/O
A12	NC	I/O	I/O
A13	I/O	I/O	I/O
A14	I/O	I/O	I/O
A15	GND	GND	GND
A16	GND	GND	GND
B1	I/O	I/O	I/O
B2	GND	GND	GND
B3	I/O	I/O	I/O
B4	I/O	I/O	I/O
B5	I/O	I/O	I/O
B6	NC	I/O	I/O
B7	I/O	I/O	I/O
B8	V <sub>CCA</sub>	V <sub>CCA</sub>	V <sub>CCA</sub>
B9	I/O	I/O	I/O
B10	I/O	I/O	I/O
B11	NC	I/O	I/O
B12	I/O	I/O	I/O
B13	I/O	I/O	I/O
B14	I/O	I/O	I/O
B15	GND	GND	GND
B16	I/O	I/O	I/O
C1	I/O	I/O	I/O
C2	TDI, I/O	TDI, I/O	TDI, I/O
C3	GND	GND	GND
C4	I/O	I/O	I/O
C5	NC	I/O	I/O

256-Pin FBGA			
Pin Number	A54SX16A Function	A54SX32A Function	A54SX72A Function
C6	I/O	I/O	I/O
C7	I/O	I/O	I/O
C8	I/O	I/O	I/O
C9	CLKA	CLKA	CLKA
C10	I/O	I/O	I/O
C11	I/O	I/O	I/O
C12	I/O	I/O	I/O
C13	I/O	I/O	I/O
C14	I/O	I/O	I/O
C15	I/O	I/O	I/O
C16	I/O	I/O	I/O
D1	I/O	I/O	I/O
D2	I/O	I/O	I/O
D3	I/O	I/O	I/O
D4	I/O	I/O	I/O
D5	I/O	I/O	I/O
D6	I/O	I/O	I/O
D7	I/O	I/O	I/O
D8	PRA, I/O	PRA, I/O	PRA, I/O
D9	I/O	I/O	QCLKD
D10	I/O	I/O	I/O
D11	NC	I/O	I/O
D12	I/O	I/O	I/O
D13	I/O	I/O	I/O
D14	I/O	I/O	I/O
D15	I/O	I/O	I/O
D16	I/O	I/O	I/O
E1	I/O	I/O	I/O
E2	I/O	I/O	I/O
E3	I/O	I/O	I/O
E4	I/O	I/O	I/O
E5	I/O	I/O	I/O
E6	I/O	I/O	I/O
E7	I/O	I/O	QCLKC
E8	I/O	I/O	I/O
E9	I/O	I/O	I/O
E10	I/O	I/O	I/O

256-Pin FBGA			
Pin Number	A54SX16A Function	A54SX32A Function	A54SX72A Function
E11	I/O	I/O	I/O
E12	I/O	I/O	I/O
E13	NC	I/O	I/O
E14	I/O	I/O	I/O
E15	I/O	I/O	I/O
E16	I/O	I/O	I/O
F1	I/O	I/O	I/O
F2	I/O	I/O	I/O
F3	I/O	I/O	I/O
F4	TMS	TMS	TMS
F5	I/O	I/O	I/O
F6	I/O	I/O	I/O
F7	V <sub>CCI</sub>	V <sub>CCI</sub>	V <sub>CCI</sub>
F8	V <sub>CCI</sub>	V <sub>CCI</sub>	V <sub>CCI</sub>
F9	V <sub>CCI</sub>	V <sub>CCI</sub>	V <sub>CCI</sub>
F10	V <sub>CCI</sub>	V <sub>CCI</sub>	V <sub>CCI</sub>
F11	I/O	I/O	I/O
F12	V <sub>CCA</sub>	V <sub>CCA</sub>	V <sub>CCA</sub>
F13	I/O	I/O	I/O
F14	I/O	I/O	I/O
F15	I/O	I/O	I/O
F16	I/O	I/O	I/O
G1	NC	I/O	I/O
G2	I/O	I/O	I/O
G3	NC	I/O	I/O
G4	I/O	I/O	I/O
G5	I/O	I/O	I/O
G6	V <sub>CCI</sub>	V <sub>CCI</sub>	V <sub>CCI</sub>
G7	GND	GND	GND
G8	GND	GND	GND
G9	GND	GND	GND
G10	GND	GND	GND
G11	V <sub>CCI</sub>	V <sub>CCI</sub>	V <sub>CCI</sub>
G12	I/O	I/O	I/O
G13	GND	GND	GND
G14	NC	I/O	I/O
G15	V <sub>CCA</sub>	V <sub>CCA</sub>	V <sub>CCA</sub>

256-Pin FBGA			
Pin Number	A54SX16A Function	A54SX32A Function	A54SX72A Function
G16	I/O	I/O	I/O
H1	I/O	I/O	I/O
H2	I/O	I/O	I/O
H3	V <sub>CCA</sub>	V <sub>CCA</sub>	V <sub>CCA</sub>
H4	TRST, I/O	TRST, I/O	TRST, I/O
H5	I/O	I/O	I/O
H6	V <sub>CCI</sub>	V <sub>CCI</sub>	V <sub>CCI</sub>
H7	GND	GND	GND
H8	GND	GND	GND
H9	GND	GND	GND
H10	GND	GND	GND
H11	V <sub>CCI</sub>	V <sub>CCI</sub>	V <sub>CCI</sub>
H12	I/O	I/O	I/O
H13	I/O	I/O	I/O
H14	I/O	I/O	I/O
H15	I/O	I/O	I/O
H16	NC	I/O	I/O
J1	NC	I/O	I/O
J2	NC	I/O	I/O
J3	NC	I/O	I/O
J4	I/O	I/O	I/O
J5	I/O	I/O	I/O
J6	V <sub>CCI</sub>	V <sub>CCI</sub>	V <sub>CCI</sub>
J7	GND	GND	GND
J8	GND	GND	GND
J9	GND	GND	GND
J10	GND	GND	GND
J11	V <sub>CCI</sub>	V <sub>CCI</sub>	V <sub>CCI</sub>
J12	I/O	I/O	I/O
J13	I/O	I/O	I/O
J14	I/O	I/O	I/O
J15	I/O	I/O	I/O
J16	I/O	I/O	I/O
K1	I/O	I/O	I/O
K2	I/O	I/O	I/O
K3	NC	I/O	I/O
K4	V <sub>CCA</sub>	V <sub>CCA</sub>	V <sub>CCA</sub>

256-Pin FBGA			
Pin Number	A54SX16A Function	A54SX32A Function	A54SX72A Function
K5	I/O	I/O	I/O
K6	V <sub>CCI</sub>	V <sub>CCI</sub>	V <sub>CCI</sub>
K7	GND	GND	GND
K8	GND	GND	GND
K9	GND	GND	GND
K10	GND	GND	GND
K11	V <sub>CCI</sub>	V <sub>CCI</sub>	V <sub>CCI</sub>
K12	I/O	I/O	I/O
K13	I/O	I/O	I/O
K14	I/O	I/O	I/O
K15	NC	I/O	I/O
K16	I/O	I/O	I/O
L1	I/O	I/O	I/O
L2	I/O	I/O	I/O
L3	I/O	I/O	I/O
L4	I/O	I/O	I/O
L5	I/O	I/O	I/O
L6	I/O	I/O	I/O
L7	V <sub>CCI</sub>	V <sub>CCI</sub>	V <sub>CCI</sub>
L8	V <sub>CCI</sub>	V <sub>CCI</sub>	V <sub>CCI</sub>
L9	V <sub>CCI</sub>	V <sub>CCI</sub>	V <sub>CCI</sub>
L10	V <sub>CCI</sub>	V <sub>CCI</sub>	V <sub>CCI</sub>
L11	I/O	I/O	I/O
L12	I/O	I/O	I/O
L13	I/O	I/O	I/O
L14	I/O	I/O	I/O
L15	I/O	I/O	I/O
L16	NC	I/O	I/O
M1	I/O	I/O	I/O
M2	I/O	I/O	I/O
M3	I/O	I/O	I/O
M4	I/O	I/O	I/O
M5	I/O	I/O	I/O
M6	I/O	I/O	I/O
M7	I/O	I/O	QCLKA
M8	PRB, I/O	PRB, I/O	PRB, I/O
M9	I/O	I/O	I/O

256-Pin FBGA			
Pin Number	A54SX16A Function	A54SX32A Function	A54SX72A Function
M10	I/O	I/O	I/O
M11	I/O	I/O	I/O
M12	NC	I/O	I/O
M13	I/O	I/O	I/O
M14	NC	I/O	I/O
M15	I/O	I/O	I/O
M16	I/O	I/O	I/O
N1	I/O	I/O	I/O
N2	I/O	I/O	I/O
N3	I/O	I/O	I/O
N4	I/O	I/O	I/O
N5	I/O	I/O	I/O
N6	I/O	I/O	I/O
N7	I/O	I/O	I/O
N8	I/O	I/O	I/O
N9	I/O	I/O	I/O
N10	I/O	I/O	I/O
N11	I/O	I/O	I/O
N12	I/O	I/O	I/O
N13	I/O	I/O	I/O
N14	I/O	I/O	I/O
N15	I/O	I/O	I/O
N16	I/O	I/O	I/O
P1	I/O	I/O	I/O
P2	GND	GND	GND
P3	I/O	I/O	I/O
P4	I/O	I/O	I/O
P5	NC	I/O	I/O
P6	I/O	I/O	I/O
P7	I/O	I/O	I/O
P8	I/O	I/O	I/O
P9	I/O	I/O	I/O
P10	NC	I/O	I/O
P11	I/O	I/O	I/O
P12	I/O	I/O	I/O
P13	V <sub>CCA</sub>	V <sub>CCA</sub>	V <sub>CCA</sub>
P14	I/O	I/O	I/O

256-Pin FBGA			
Pin Number	A54SX16A Function	A54SX32A Function	A54SX72A Function
P15	I/O	I/O	I/O
P16	I/O	I/O	I/O
R1	I/O	I/O	I/O
R2	GND	GND	GND
R3	I/O	I/O	I/O
R4	NC	I/O	I/O
R5	I/O	I/O	I/O
R6	I/O	I/O	I/O
R7	I/O	I/O	I/O
R8	I/O	I/O	I/O
R9	HCLK	HCLK	HCLK
R10	I/O	I/O	QCLKB
R11	I/O	I/O	I/O
R12	I/O	I/O	I/O
R13	I/O	I/O	I/O
R14	I/O	I/O	I/O
R15	GND	GND	GND
R16	GND	GND	GND
T1	GND	GND	GND
T2	I/O	I/O	I/O
T3	I/O	I/O	I/O
T4	NC	I/O	I/O
T5	I/O	I/O	I/O
T6	I/O	I/O	I/O
T7	I/O	I/O	I/O
T8	I/O	I/O	I/O
T9	V <sub>CCA</sub>	V <sub>CCA</sub>	V <sub>CCA</sub>
T10	I/O	I/O	I/O
T11	I/O	I/O	I/O
T12	NC	I/O	I/O
T13	I/O	I/O	I/O
T14	I/O	I/O	I/O
T15	TDO, I/O	TDO, I/O	TDO, I/O
T16	GND	GND	GND

# 484-Pin FBGA



Figure 3-8 • 484-Pin FBGA (Top View)

## Note

For Package Manufacturing and Environmental information, visit Resource center at <http://www.actel.com/products/rescenter/package/index.html>.

484-Pin FBGA		
Pin Number	A54SX32A Function	A54SX72A Function
A1	NC*	NC
A2	NC*	NC
A3	NC*	I/O
A4	NC*	I/O
A5	NC*	I/O
A6	I/O	I/O
A7	I/O	I/O
A8	I/O	I/O
A9	I/O	I/O
A10	I/O	I/O
A11	NC*	I/O
A12	NC*	I/O
A13	I/O	I/O
A14	NC*	NC
A15	NC*	I/O
A16	NC*	I/O
A17	I/O	I/O
A18	I/O	I/O
A19	I/O	I/O
A20	I/O	I/O
A21	NC*	I/O
A22	NC*	I/O
A23	NC*	I/O
A24	NC*	I/O
A25	NC*	NC
A26	NC*	NC
AA1	NC*	I/O
AA2	NC*	I/O
AA3	V <sub>CCA</sub>	V <sub>CCA</sub>
AA4	I/O	I/O
AA5	I/O	I/O
AA22	I/O	I/O
AA23	I/O	I/O
AA24	I/O	I/O
AA25	NC*	I/O

484-Pin FBGA		
Pin Number	A54SX32A Function	A54SX72A Function
AA26	NC*	I/O
AB1	NC*	NC
AB2	V <sub>CCI</sub>	V <sub>CCI</sub>
AB3	I/O	I/O
AB4	I/O	I/O
AB5	NC*	I/O
AB6	I/O	I/O
AB7	I/O	I/O
AB8	I/O	I/O
AB9	I/O	I/O
AB10	I/O	I/O
AB11	I/O	I/O
AB12	PRB, I/O	PRB, I/O
AB13	V <sub>CCA</sub>	V <sub>CCA</sub>
AB14	I/O	I/O
AB15	I/O	I/O
AB16	I/O	I/O
AB17	I/O	I/O
AB18	I/O	I/O
AB19	I/O	I/O
AB20	TDO, I/O	TDO, I/O
AB21	GND	GND
AB22	NC*	I/O
AB23	I/O	I/O
AB24	I/O	I/O
AB25	NC*	I/O
AB26	NC*	I/O
AC1	I/O	I/O
AC2	I/O	I/O
AC3	I/O	I/O
AC4	NC*	I/O
AC5	V <sub>CCI</sub>	V <sub>CCI</sub>
AC6	I/O	I/O
AC7	V <sub>CCI</sub>	V <sub>CCI</sub>
AC8	I/O	I/O

484-Pin FBGA		
Pin Number	A54SX32A Function	A54SX72A Function
AC9	I/O	I/O
AC10	I/O	I/O
AC11	I/O	I/O
AC12	I/O	QCLKA
AC13	I/O	I/O
AC14	I/O	I/O
AC15	I/O	I/O
AC16	I/O	I/O
AC17	I/O	I/O
AC18	I/O	I/O
AC19	I/O	I/O
AC20	V <sub>CCI</sub>	V <sub>CCI</sub>
AC21	I/O	I/O
AC22	I/O	I/O
AC23	NC*	I/O
AC24	I/O	I/O
AC25	NC*	I/O
AC26	NC*	I/O
AD1	I/O	I/O
AD2	I/O	I/O
AD3	GND	GND
AD4	I/O	I/O
AD5	I/O	I/O
AD6	I/O	I/O
AD7	I/O	I/O
AD8	I/O	I/O
AD9	V <sub>CCI</sub>	V <sub>CCI</sub>
AD10	I/O	I/O
AD11	I/O	I/O
AD12	I/O	I/O
AD13	V <sub>CCI</sub>	V <sub>CCI</sub>
AD14	I/O	I/O
AD15	I/O	I/O
AD16	I/O	I/O
AD17	V <sub>CCI</sub>	V <sub>CCI</sub>

**Note:** \*These pins must be left floating on the A54SX32A device.

484-Pin FBGA		
Pin Number	A54SX32A Function	A54SX72A Function
AD18	I/O	I/O
AD19	I/O	I/O
AD20	I/O	I/O
AD21	I/O	I/O
AD22	I/O	I/O
AD23	V <sub>CCI</sub>	V <sub>CCI</sub>
AD24	NC*	I/O
AD25	NC*	I/O
AD26	NC*	I/O
AE1	NC*	NC
AE2	I/O	I/O
AE3	NC*	I/O
AE4	NC*	I/O
AE5	NC*	I/O
AE6	NC*	I/O
AE7	I/O	I/O
AE8	I/O	I/O
AE9	I/O	I/O
AE10	I/O	I/O
AE11	NC*	I/O
AE12	I/O	I/O
AE13	I/O	I/O
AE14	I/O	I/O
AE15	NC*	I/O
AE16	NC*	I/O
AE17	I/O	I/O
AE18	I/O	I/O
AE19	I/O	I/O
AE20	I/O	I/O
AE21	NC*	I/O
AE22	NC*	I/O
AE23	NC*	I/O
AE24	NC*	I/O
AE25	NC*	NC
AE26	NC*	NC

484-Pin FBGA		
Pin Number	A54SX32A Function	A54SX72A Function
AF1	NC*	NC
AF2	NC*	NC
AF3	NC	I/O
AF4	NC*	I/O
AF5	NC*	I/O
AF6	NC*	I/O
AF7	I/O	I/O
AF8	I/O	I/O
AF9	I/O	I/O
AF10	I/O	I/O
AF11	NC*	I/O
AF12	NC*	NC
AF13	HCLK	HCLK
AF14	I/O	QCLKB
AF15	NC*	I/O
AF16	NC*	I/O
AF17	I/O	I/O
AF18	I/O	I/O
AF19	I/O	I/O
AF20	NC*	I/O
AF21	NC*	I/O
AF22	NC*	I/O
AF23	NC*	I/O
AF24	NC*	I/O
AF25	NC*	NC
AF26	NC*	NC
B1	NC*	NC
B2	NC*	NC
B3	NC*	I/O
B4	NC*	I/O
B5	NC*	I/O
B6	I/O	I/O
B7	I/O	I/O
B8	I/O	I/O
B9	I/O	I/O

484-Pin FBGA		
Pin Number	A54SX32A Function	A54SX72A Function
B10	I/O	I/O
B11	NC*	I/O
B12	NC*	I/O
B13	V <sub>CCI</sub>	V <sub>CCI</sub>
B14	CLKA	CLKA
B15	NC*	I/O
B16	NC*	I/O
B17	I/O	I/O
B18	V <sub>CCI</sub>	V <sub>CCI</sub>
B19	I/O	I/O
B20	I/O	I/O
B21	NC*	I/O
B22	NC*	I/O
B23	NC*	I/O
B24	NC*	I/O
B25	I/O	I/O
B26	NC*	NC
C1	NC*	I/O
C2	NC*	I/O
C3	NC*	I/O
C4	NC*	I/O
C5	I/O	I/O
C6	V <sub>CCI</sub>	V <sub>CCI</sub>
C7	I/O	I/O
C8	I/O	I/O
C9	V <sub>CCI</sub>	V <sub>CCI</sub>
C10	I/O	I/O
C11	I/O	I/O
C12	I/O	I/O
C13	PRA, I/O	PRA, I/O
C14	I/O	I/O
C15	I/O	QCLKD
C16	I/O	I/O
C17	I/O	I/O
C18	I/O	I/O

**Note:** \*These pins must be left floating on the A54SX32A device.

484-Pin FBGA		
Pin Number	A54SX32A Function	A54SX72A Function
C19	I/O	I/O
C20	V <sub>CCI</sub>	V <sub>CCI</sub>
C21	I/O	I/O
C22	I/O	I/O
C23	I/O	I/O
C24	I/O	I/O
C25	NC*	I/O
C26	NC*	I/O
D1	NC*	I/O
D2	TMS	TMS
D3	I/O	I/O
D4	V <sub>CCI</sub>	V <sub>CCI</sub>
D5	NC*	I/O
D6	TCK, I/O	TCK, I/O
D7	I/O	I/O
D8	I/O	I/O
D9	I/O	I/O
D10	I/O	I/O
D11	I/O	I/O
D12	I/O	QCLKC
D13	I/O	I/O
D14	I/O	I/O
D15	I/O	I/O
D16	I/O	I/O
D17	I/O	I/O
D18	I/O	I/O
D19	I/O	I/O
D20	I/O	I/O
D21	V <sub>CCI</sub>	V <sub>CCI</sub>
D22	GND	GND
D23	I/O	I/O
D24	I/O	I/O
D25	NC*	I/O
D26	NC*	I/O
E1	NC*	I/O

484-Pin FBGA		
Pin Number	A54SX32A Function	A54SX72A Function
E2	NC*	I/O
E3	I/O	I/O
E4	I/O	I/O
E5	GND	GND
E6	TDI, IO	TDI, IO
E7	I/O	I/O
E8	I/O	I/O
E9	I/O	I/O
E10	I/O	I/O
E11	I/O	I/O
E12	I/O	I/O
E13	V <sub>CCA</sub>	V <sub>CCA</sub>
E14	CLKB	CLKB
E15	I/O	I/O
E16	I/O	I/O
E17	I/O	I/O
E18	I/O	I/O
E19	I/O	I/O
E20	I/O	I/O
E21	I/O	I/O
E22	I/O	I/O
E23	I/O	I/O
E24	I/O	I/O
E25	V <sub>CCI</sub>	V <sub>CCI</sub>
E26	GND	GND
F1	V <sub>CCI</sub>	V <sub>CCI</sub>
F2	NC*	I/O
F3	NC*	I/O
F4	I/O	I/O
F5	I/O	I/O
F22	I/O	I/O
F23	I/O	I/O
F24	I/O	I/O
F25	I/O	I/O
F26	NC*	I/O

484-Pin FBGA		
Pin Number	A54SX32A Function	A54SX72A Function
G1	NC*	I/O
G2	NC*	I/O
G3	NC*	I/O
G4	I/O	I/O
G5	I/O	I/O
G22	I/O	I/O
G23	V <sub>CCA</sub>	V <sub>CCA</sub>
G24	I/O	I/O
G25	NC*	I/O
G26	NC*	I/O
H1	NC*	I/O
H2	NC*	I/O
H3	I/O	I/O
H4	I/O	I/O
H5	I/O	I/O
H22	I/O	I/O
H23	I/O	I/O
H24	I/O	I/O
H25	NC*	I/O
H26	NC*	I/O
J1	NC*	I/O
J2	NC*	I/O
J3	I/O	I/O
J4	I/O	I/O
J5	I/O	I/O
J22	I/O	I/O
J23	I/O	I/O
J24	I/O	I/O
J25	V <sub>CCI</sub>	V <sub>CCI</sub>
J26	NC*	I/O
K1	I/O	I/O
K2	V <sub>CCI</sub>	V <sub>CCI</sub>
K3	I/O	I/O
K4	I/O	I/O
K5	V <sub>CCA</sub>	V <sub>CCA</sub>

**Note:** \*These pins must be left floating on the A54SX32A device.

484-Pin FBGA		
Pin Number	A54SX32A Function	A54SX72A Function
K10	GND	GND
K11	GND	GND
K12	GND	GND
K13	GND	GND
K14	GND	GND
K15	GND	GND
K16	GND	GND
K17	GND	GND
K22	I/O	I/O
K23	I/O	I/O
K24	NC*	NC
K25	NC*	I/O
K26	NC*	I/O
L1	NC*	I/O
L2	NC*	I/O
L3	I/O	I/O
L4	I/O	I/O
L5	I/O	I/O
L10	GND	GND
L11	GND	GND
L12	GND	GND
L13	GND	GND
L14	GND	GND
L15	GND	GND
L16	GND	GND
L17	GND	GND
L22	I/O	I/O
L23	I/O	I/O
L24	I/O	I/O
L25	I/O	I/O
L26	I/O	I/O
M1	NC*	NC
M2	I/O	I/O
M3	I/O	I/O
M4	I/O	I/O

484-Pin FBGA		
Pin Number	A54SX32A Function	A54SX72A Function
M5	I/O	I/O
M10	GND	GND
M11	GND	GND
M12	GND	GND
M13	GND	GND
M14	GND	GND
M15	GND	GND
M16	GND	GND
M17	GND	GND
M22	I/O	I/O
M23	I/O	I/O
M24	I/O	I/O
M25	NC*	I/O
M26	NC*	I/O
N1	I/O	I/O
N2	V <sub>CCI</sub>	V <sub>CCI</sub>
N3	I/O	I/O
N4	I/O	I/O
N5	I/O	I/O
N10	GND	GND
N11	GND	GND
N12	GND	GND
N13	GND	GND
N14	GND	GND
N15	GND	GND
N16	GND	GND
N17	GND	GND
N22	V <sub>CCA</sub>	V <sub>CCA</sub>
N23	I/O	I/O
N24	I/O	I/O
N25	I/O	I/O
N26	NC*	NC
P1	NC*	I/O
P2	NC*	I/O
P3	I/O	I/O

484-Pin FBGA		
Pin Number	A54SX32A Function	A54SX72A Function
P4	I/O	I/O
P5	V <sub>CCA</sub>	V <sub>CCA</sub>
P10	GND	GND
P11	GND	GND
P12	GND	GND
P13	GND	GND
P14	GND	GND
P15	GND	GND
P16	GND	GND
P17	GND	GND
P22	I/O	I/O
P23	I/O	I/O
P24	V <sub>CCI</sub>	V <sub>CCI</sub>
P25	I/O	I/O
P26	I/O	I/O
R1	NC*	I/O
R2	NC*	I/O
R3	I/O	I/O
R4	I/O	I/O
R5	TRST, I/O	TRST, I/O
R10	GND	GND
R11	GND	GND
R12	GND	GND
R13	GND	GND
R14	GND	GND
R15	GND	GND
R16	GND	GND
R17	GND	GND
R22	I/O	I/O
R23	I/O	I/O
R24	I/O	I/O
R25	NC*	I/O
R26	NC*	I/O
T1	NC*	I/O
T2	NC*	I/O

**Note:** \*These pins must be left floating on the A54SX32A device.

484-Pin FBGA		
Pin Number	A54SX32A Function	A54SX72A Function
T3	I/O	I/O
T4	I/O	I/O
T5	I/O	I/O
T10	GND	GND
T11	GND	GND
T12	GND	GND
T13	GND	GND
T14	GND	GND
T15	GND	GND
T16	GND	GND
T17	GND	GND
T22	I/O	I/O
T23	I/O	I/O
T24	I/O	I/O
T25	NC*	I/O
T26	NC*	I/O
U1	I/O	I/O
U2	V <sub>CCI</sub>	V <sub>CCI</sub>
U3	I/O	I/O
U4	I/O	I/O
U5	I/O	I/O
U10	GND	GND
U11	GND	GND
U12	GND	GND
U13	GND	GND
U14	GND	GND
U15	GND	GND
U16	GND	GND
U17	GND	GND
U22	I/O	I/O
U23	I/O	I/O
U24	I/O	I/O
U25	V <sub>CCI</sub>	V <sub>CCI</sub>
U26	I/O	I/O
V1	NC*	I/O

484-Pin FBGA		
Pin Number	A54SX32A Function	A54SX72A Function
V2	NC*	I/O
V3	I/O	I/O
V4	I/O	I/O
V5	I/O	I/O
V22	V <sub>CCA</sub>	V <sub>CCA</sub>
V23	I/O	I/O
V24	I/O	I/O
V25	NC*	I/O
V26	NC*	I/O
W1	I/O	I/O
W2	I/O	I/O
W3	I/O	I/O
W4	I/O	I/O
W5	I/O	I/O
W22	I/O	I/O
W23	V <sub>CCA</sub>	V <sub>CCA</sub>
W24	I/O	I/O
W25	NC*	I/O
W26	NC*	I/O
Y1	NC*	I/O
Y2	NC*	I/O
Y3	I/O	I/O
Y4	I/O	I/O
Y5	NC*	I/O
Y22	I/O	I/O
Y23	I/O	I/O
Y24	V <sub>CCI</sub>	V <sub>CCI</sub>
Y25	I/O	I/O
Y26	I/O	I/O

**Note:** \*These pins must be left floating on the A54SX32A device.



# Datasheet Information

## List of Changes

The following table lists critical changes that were made in the current version of the document.

Previous Version	Changes in Current Version (v5.3)	Page
v5.2 (June 2006)	–3 speed grades have been discontinued.	N/A
	The "SX-A Timing Model" was updated with –2 data.	2-14
v5.1 February 2005	RoHS information was added to the "Ordering Information".	ii
	The "Programming" section was updated.	1-13
v5.0	Revised Table 1 and the timing data to reflect the phase out of the –3 speed grade for the A54SX08A device.	i
	The "Thermal Characteristics" section was updated.	2-11
	The "176-Pin TQFP" was updated to add pins 81 to 90.	3-11
	The "484-Pin FBGA" was updated to add pins R4 to Y26	3-26
v4.0	The "Temperature Grade Offering" is new.	1-iii
	The "Speed Grade and Temperature Grade Matrix" is new.	1-iii
	"SX-A Family Architecture" was updated.	1-1
	"Clock Resources" was updated.	1-5
	"User Security" was updated.	1-7
	"Power-Up/Down and Hot Swapping" was updated.	1-7
	"Dedicated Mode" is new	1-9
	Table 1-5 is new.	1-9
	"JTAG Instructions" is new	1-10
	"Design Considerations" was updated.	1-12
	The "Programming" section is new.	1-13
	"Design Environment" was updated.	1-13
	"Pin Description" was updated.	1-15
	Table 2-1 was updated.	2-1
	Table 2-2 was updated.	2-1
	Table 2-3 is new.	2-1
	Table 2-4 is new.	2-1
	Table 2-5 was updated.	2-2
	Table 2-6 was updated.	2-2
	"Power Dissipation" is new.	2-8
Table 2-11 was updated.	2-9	

Previous Version	Changes in Current Version (v5.3)	Page
v4.0 (continued)	Table 2-12 was updated.	2-11
	The was updated.	2-14
	The "Sample Path Calculations" were updated.	2-14
	Table 2-13 was updated.	2-17
	Table 2-13 was updated.	2-17
	All timing tables were updated.	2-18 to 2-52
v3.0	The "Actel Secure Programming Technology with FuseLock™ Prevents Reverse Engineering and Design Theft" section was updated.	1-i
	The "Ordering Information" section was updated.	1-ii
	The "Temperature Grade Offering" section was updated.	1-iii
	The Figure 1-1 • SX-A Family Interconnect Elements was updated.	1-1
	The "Clock Resources" section was updated	1-5
	The Table 1-1 • SX-A Clock Resources is new.	1-5
	The "User Security" section is new.	1-7
	The "I/O Modules" section was updated.	1-7
	The Table 1-2 • I/O Features was updated.	1-8
	The Table 1-3 • I/O Characteristics for All I/O Configurations is new.	1-8
	The Table 1-4 • Power-Up Time at which I/Os Become Active is new	1-8
	The Figure 1-12 • Device Selection Wizard is new.	1-9
	The "Boundary-Scan Pin Configurations and Functions" section is new.	1-9
	The Table 1-9 • Device Configuration Options for Probe Capability (TRST Pin Reserved) is new.	1-11
	The "SX-A Probe Circuit Control Pins" section was updated.	1-12
	The "Design Considerations" section was updated.	1-12
	The Figure 1-13 • Probe Setup was updated.	1-12
	The Design Environment was updated.	1-13
	The Figure 1-13 • Design Flow is new.	1-11
	The "Absolute Maximum Ratings*" section was updated.	1-12
	The "Recommended Operating Conditions" section was updated.	1-12
	The "Electrical Specifications" section was updated.	1-12
	The "2.5V LVCMOS2 Electrical Specifications" section was updated.	1-13
	The "SX-A Timing Model" and "Sample Path Calculations" equations were updated.	1-23
The "Pin Description" section was updated.	1-15	
v2.0.1	The "Design Environment" section has been updated.	1-13
	The "I/O Modules" section, and Table 1-2 • I/O Features have been updated.	1-8
	The "SX-A Timing Model" section and the "Timing Characteristics" section have new timing numbers.	1-23

## Datasheet Categories

In order to provide the latest information to designers, some datasheets are published before data has been fully characterized. Datasheets are designated as "Product Brief," "Advanced," "Production," and "Datasheet Supplement." The definitions of these categories are as follows:

### Product Brief

The product brief is a summarized version of a datasheet (advanced or production) containing general product information. This brief gives an overview of specific device and family information.

### Advanced

This datasheet version contains initial estimated information based on simulation, other products, devices, or speed grades. This information can be used as estimates, but not for production.

### Unmarked (production)

This datasheet version contains information that is considered to be final.

### Datasheet Supplement

The datasheet supplement gives specific device information for a derivative family that differs from the general family datasheet. The supplement is to be used in conjunction with the datasheet to obtain more detailed information and for specifications that do not differ between the two families.

## International Traffic in Arms Regulations (ITAR) and Export Administration Regulations (EAR)

The products described in this datasheet are subject to the International Traffic in Arms Regulations (ITAR) or the Export Administration Regulations (EAR). They may require an approved export license prior to their export. An export can include a release or disclosure to a foreign national inside or outside the United States.

Actel and the Actel logo are registered trademarks of Actel Corporation.  
All other trademarks are the property of their owners.



[www.actel.com](http://www.actel.com)

**Actel Corporation**

2061 Stierlin Court  
Mountain View, CA  
94043-4655 USA

**Phone** 650.318.4200

**Fax** 650.318.4600

**Actel Europe Ltd.**

River Court, Meadows Business Park  
Station Approach, Blackwater  
Camberley, Surrey GU17 9AB  
United Kingdom

**Phone** +44 (0) 1276 609 300

**Fax** +44 (0) 1276 607 540

**Actel Japan**

EXOS Ebisu Bldg. 4F  
1-24-14 Ebisu Shibuya-ku  
Tokyo 150 Japan

**Phone** +81.03.3445.7671

**Fax** +81.03.3445.7668

[www.jp.actel.com](http://www.jp.actel.com)

**Actel Hong Kong**

Suite 2114, Two Pacific Place  
88 Queensway, Admiralty  
Hong Kong

**Phone** +852 2185 6460

**Fax** +852 2185 6488

[www.actel.com.cn](http://www.actel.com.cn)

## Looking for pricing, stock, or lifecycle information?

Click below to explore more details on WIN SOURCE:

 [View A54SX72A-PQG208 on WIN SOURCE](#)

 [Microsemi Corporation](#) Information

## Optimize Your Supply Chain with WIN SOURCE Solutions

-  Global Sourcing Solution
-  Obsolete Management
-  Cost Control Management
-  Shortage Management
-  Alternative Solution
-  Excess Inventory Management