



**THE DATASHEET OF  
AD5531BRUZ**



### FEATURES

- Pin-compatible 12-, 14-bit digital-to-analog converters
- Serial input, voltage output
- Maximum output voltage range of  $\pm 10$  V
- Data readback
- 3-wire serial interface
- Clear function to a user-defined voltage
- Power-down function
- Serial data output for daisy-chaining
- 16-lead TSSOP

### APPLICATIONS

- Industrial automation
- Automatic test equipment
- Process control
- General-purpose instrumentation

### GENERAL DESCRIPTION

The AD5530/AD5531 are single 12- and 14-bit (respectively) serial input, voltage output digital-to-analog converters (DAC).

They utilize a versatile 3-wire interface that is compatible with SPI®, QSPI™, MICROWIRE™, and DSP interface standards. Data is presented to the part in a 16-bit serial word format. Serial data is available on the SDO pin for daisy-chaining purposes. Data readback allows the user to read the contents of the DAC register via the SDO pin.

### FUNCTIONAL BLOCK DIAGRAM

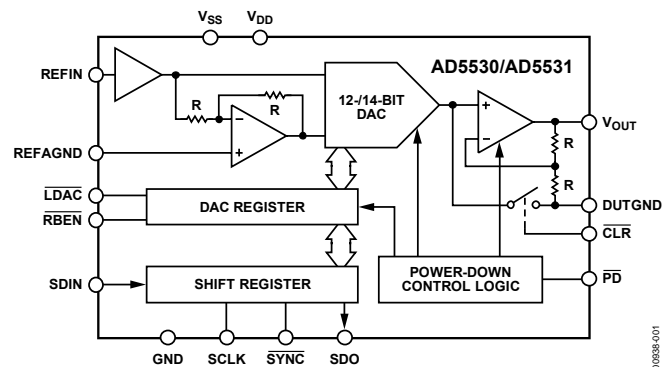

Figure 1.

The DAC output is buffered by a gain of two amplifier and referenced to the potential at DUTGND. LDAC can be used to update the output of the DAC asynchronously. A power-down pin (PD) allows the DAC to be put into a low power state, and a CLR pin allows the output to be cleared to a user-defined voltage, the potential at DUTGND.

The AD5530/AD5531 are available in 16-lead TSSOP.

### Rev. B

Information furnished by Analog Devices is believed to be accurate and reliable. However, no responsibility is assumed by Analog Devices for its use, nor for any infringements of patents or other rights of third parties that may result from its use. Specifications subject to change without notice. No license is granted by implication or otherwise under any patent or patent rights of Analog Devices. Trademarks and registered trademarks are the property of their respective owners.

## TABLE OF CONTENTS

Features .....	1	$\overline{\text{PD}}$ Function .....	13
Applications .....	1	Readback Function .....	13
Functional Block Diagram .....	1	$\overline{\text{CLR}}$ Function .....	13
General Description .....	1	Output Voltage .....	14
Revision History .....	2	Bipolar Configuration .....	14
Specifications .....	3	Microprocessor Interfacing .....	15
AC Performance Characteristics .....	5	AD5530/AD5531 to ADSP-21xx .....	15
Standalone Timing Characteristics .....	5	AD5530/AD5531 to 8051 Interface .....	15
Daisy-Chaining and Readback Timing Characteristics .....	6	AD5530/AD5531 to MC68HC11 Interface .....	15
Absolute Maximum Ratings .....	7	Applications Information .....	17
ESD Caution .....	7	Optocoupler Interface .....	17
Pin Configuration and Function Descriptions .....	8	Serial Interface to Multiple AD5530s or AD5531s .....	17
Typical Performance Characteristics .....	9	Daisy-Chaining Interface with Multiple AD5530s or AD5531s .....	17
Terminology .....	12	Outline Dimensions .....	18
Theory of Operation .....	13	Ordering Guide .....	18
DAC Architecture .....	13		
Serial Interface .....	13		

## REVISION HISTORY

### 1/07—Rev. A to Rev. B

Updated Format .....	Universal
Changes to Figure 28 .....	17

### 3/06—Rev. 0 to Rev. A

Change to Table 3 .....	5
Change to Figure 4 .....	8
Change to Output Voltage Section .....	14
Change to Ordering Guide .....	18

### 5/02—Revision 0: Initial Version

## SPECIFICATIONS

$V_{DD} = 15\text{ V} \pm 10\%$ ;  $V_{SS} = -15\text{ V} \pm 10\%$ ;  $GND = 0\text{ V}$ ;  $R_L = 5\text{ k}\Omega$  and  $C_L = 220\text{ pF}$  to  $GND$ . All specifications  $T_{MIN}$  to  $T_{MAX}$ , unless otherwise noted.

Table 1.

Parameter <sup>1</sup>	AD5530	AD5531	Unit	Test Conditions/Comments
<b>ACCURACY</b>				
Resolution	12	14	Bits	
Relative Accuracy	$\pm 1$	$\pm 2$	LSB max	
Differential Nonlinearity	$\pm 1$	$\pm 1$	LSB max	Guaranteed monotonic over temperature
Zero-Scale Error	$\pm 2$	$\pm 8$	LSB max	Typically within $\pm 1$ LSB
Full-Scale Error	$\pm 2$	$\pm 8$	LSB max	Typically within $\pm 1$ LSB
Gain Error	$\pm 1$	$\pm 4$	LSB typ	
Gain Temperature Coefficient <sup>2</sup>	0.5	0.5	ppm FSR/ $^{\circ}\text{C}$ typ	
	10	10	ppm FSR/ $^{\circ}\text{C}$ max	
<b>REFERENCE INPUTS<sup>2</sup></b>				
Reference Input Range	0 to 5	0 to 5	V min to V max	Max output range $\pm 10\text{ V}$
DC Input Resistance	100	100	M $\Omega$ typ	
Input Current	$\pm 1$	$\pm 1$	$\mu\text{A}$ max	Per input, typically $\pm 20\text{ nA}$
<b>DUTGND INPUT<sup>2</sup></b>				
DC Input Impedance	60	60	k $\Omega$ typ	
Max Input Current	$\pm 0.3$	$\pm 0.3$	mA typ	
Input Range	-4 to +4	-4 to +4	V min to V max	Max output range $\pm 10\text{ V}$
<b>O/P CHARACTERISTICS<sup>2</sup></b>				
Output Voltage Swing	$\pm 10$	$\pm 10$	V max	
Short-Circuit Current	15	15	mA max	
Resistive Load	5	5	k $\Omega$ min	To 0 V
Capacitive Load	1200	1200	pF max	To 0 V
DC Output Impedance	0.5	0.5	$\Omega$ max	
<b>DIGITAL I/O</b>				
$V_{INH}$ , Input High Voltage	2.4	2.4	V min	
$V_{INL}$ , Input Low Voltage	0.8	0.8	V max	
$I_{INH}$ , Input Current	$\pm 10$	$\pm 10$	$\mu\text{A}$ max	Total for all pins
$C_{IN}$ , Input Capacitance <sup>2</sup>	10	10	pF max	3 pF typical
SDO $V_{OL}$ , Output Low Voltage	0.4	0.4	V max	$I_{SINK} = 1\text{ mA}$
<b>POWER REQUIREMENTS</b>				
$V_{DD}/V_{SS}$	+15/-15	+15/-15	V nom	$\pm 10\%$ for specified performance
Power Supply Sensitivity				
$\Delta\text{Full Scale}/\Delta V_{DD}$	110	110	dB typ	
$\Delta\text{Full Scale}/\Delta V_{SS}$	100	100	dB typ	
$I_{DD}$	2	2	mA max	Outputs unloaded
$I_{SS}$	2	2	mA max	Outputs unloaded
$I_{DD}$ in Power-Down	150	150	$\mu\text{A}$ max	Typically 50 $\mu\text{A}$

<sup>1</sup> Temperature range for B Version:  $-40^{\circ}\text{C}$  to  $+85^{\circ}\text{C}$ .

<sup>2</sup> Guaranteed by design, not subject to production test.

# AD5530/AD5531

$V_{DD} = 12\text{ V} \pm 10\%$ ;  $V_{SS} = -12\text{ V} \pm 10\%$ ;  $GND = 0\text{ V}$ ;  $R_L = 5\text{ k}\Omega$  and  $C_L = 220\text{ pF}$  to  $GND$ ;  $T_A = T_{MIN}$  to  $T_{MAX}$ , unless otherwise noted.

**Table 2.**

Parameter <sup>1</sup>	AD5530	AD5531	Unit	Test Conditions/Comments
<b>ACCURACY</b>				
Resolution	12	14	Bits	
Relative Accuracy	$\pm 1$	$\pm 2$	LSB max	
Differential Nonlinearity	$\pm 1$	$\pm 1$	LSB max	Guaranteed monotonic over temperature
Zero-Scale Error	$\pm 2$	$\pm 8$	LSB max	Typically within $\pm 1$ LSB
Full-Scale Error	$\pm 2$	$\pm 8$	LSB max	Typically within $\pm 1$ LSB
Gain Error	$\pm 1$	$\pm 4$	LSB typ	
Gain Temperature Coefficient <sup>2</sup>	0.5	0.5	ppm FSR/ $^{\circ}\text{C}$ typ	
	10	10	ppm FSR/ $^{\circ}\text{C}$ max	
<b>REFERENCE INPUTS<sup>2</sup></b>				
Reference Input Range	0 to 4.096	0 to 4.096	V min to V max	Max output range $\pm 8.192\text{ V}$
DC Input Resistance	100	100	M $\Omega$ typ	
Input Current	$\pm 1$	$\pm 1$	$\mu\text{A}$ max	Per input, typically $\pm 20\text{ nA}$
<b>DUTGND INPUT<sup>2</sup></b>				
DC Input Impedance	60	60	k $\Omega$ typ	
Max Input Current	$\pm 0.3$	$\pm 0.3$	mA typ	
Input Range	-3 to +3	-3 to +3	V min to V max	Max output range $\pm 8.192\text{ V}$
<b>O/P CHARACTERISTICS<sup>2</sup></b>				
Output Voltage Swing	$\pm 8.192$	$\pm 8.192$	V max	
Short-Circuit Current	15	15	mA max	
Resistive Load	5	5	k $\Omega$ min	To 0 V
Capacitive Load	1200	1200	pF max	To 0 V
DC Output Impedance	0.5	0.5	$\Omega$ max	
<b>DIGITAL I/O</b>				
$V_{INH}$ , Input High Voltage	2.4	2.4	V min	
$V_{INL}$ , Input Low Voltage	0.8	0.8	V max	
$I_{INH}$ , Input Current	$\pm 10$	$\pm 10$	$\mu\text{A}$ max	Total for all pins
$C_{IN}$ , Input Capacitance <sup>2</sup>	10	10	pF max	3 pF typical
SDO $V_{OL}$ , Output Low Voltage	0.4	0.4	V max	$I_{SINK} = 1\text{ mA}$
<b>POWER REQUIREMENTS</b>				
$V_{DD}/V_{SS}$	+12/-12	+12/-12	V nom	$\pm 10\%$ for specified performance
Power Supply Sensitivity				
$\Delta$ Full Scale/ $\Delta V_{DD}$	110	110	dB typ	
$\Delta$ Full Scale/ $\Delta V_{SS}$	100	100	dB typ	
$I_{DD}$	2	2	mA max	Outputs unloaded
$I_{SS}$	2	2	mA max	Outputs unloaded
$I_{DD}$ in Power-Down	150	150	$\mu\text{A}$ max	Typically 50 $\mu\text{A}$

<sup>1</sup> Temperature range for B Version:  $-40^{\circ}\text{C}$  to  $+85^{\circ}\text{C}$ .

<sup>2</sup> Guaranteed by design, not subject to production test.

## AC PERFORMANCE CHARACTERISTICS

$V_{DD} = 10.8\text{ V to }16.5\text{ V}$ ,  $V_{SS} = -10.8\text{ V to }-16.5\text{ V}$ ;  $GND = 0\text{ V}$ ;  $R_L = 5\text{ k}\Omega$  and  $C_L = 220\text{ pF to GND}$ . All specifications  $T_{MIN}$  to  $T_{MAX}$ , unless otherwise noted.

Table 3.

Parameter	B Version	Unit	Test Conditions/Comments
<b>DYNAMIC PERFORMANCE</b>			
Output Voltage Settling Time	20	$\mu\text{s typ}$	Full-scale change to $\pm\frac{1}{2}$ LSB. DAC latch contents alternately loaded with all 0s and all 1s.
Slew Rate	1.3	$\text{V}/\mu\text{s typ}$	
Digital-to-Analog Glitch Impulse	120	$\text{nV-s typ}$	DAC latch alternately loaded with 0x0FFF and 0x1000. Not dependent on load conditions.
Digital Feedthrough	0.5	$\text{nV-s typ}$	Effect of input bus activity on DAC output under test.
Output Noise Spectral Density @ 1 kHz	100	$\text{nV}/\sqrt{\text{Hz typ}}$	All 1s loaded to DAC.

## STANDALONE TIMING CHARACTERISTICS

$V_{DD} = 10.8\text{ V to }16.5\text{ V}$ ,  $V_{SS} = -10.8\text{ V to }-16.5\text{ V}$ ;  $GND = 0\text{ V}$ ;  $R_L = 5\text{ k}\Omega$  and  $C_L = 220\text{ pF to GND}$ . All specifications  $T_{MIN}$  to  $T_{MAX}$ , unless otherwise noted.

Table 4.

Parameter <sup>1, 2</sup>	Limit at $T_{MIN}, T_{MAX}$	Unit	Description
$f_{MAX}$	7	MHz max	SCLK frequency
$t_1$	140	ns min	SCLK cycle time
$t_2$	60	ns min	SCLK low time
$t_3$	60	ns min	SCLK high time
$t_4$	50	ns min	$\overline{\text{SYNC}}$ to SCLK falling edge setup time
$t_5$	40	ns min	SCLK falling edge to $\overline{\text{SYNC}}$ rising edge
$t_6$	50	ns min	Min $\overline{\text{SYNC}}$ high time
$t_7$	40	ns min	Data setup time
$t_8$	15	ns min	Data hold time
$t_9$	5	ns min	$\overline{\text{SYNC}}$ high to LDAC low
$t_{10}$	50	ns min	LDAC pulse width
$t_{11}$	5	ns min	LDAC high to $\overline{\text{SYNC}}$ low
$t_{12}$	50	ns min	$\overline{\text{CLR}}$ pulse width

<sup>1</sup> Guaranteed by design, not subject to production test.

<sup>2</sup> Sample tested during initial release and after any redesign or process change that can affect this parameter. All input signals are measured with  $t_R = t_F = 5\text{ ns}$  (10% to 90% of  $V_{DD}$ ) and timed from a voltage level of  $(V_{IL} + V_{IH})/2$ .

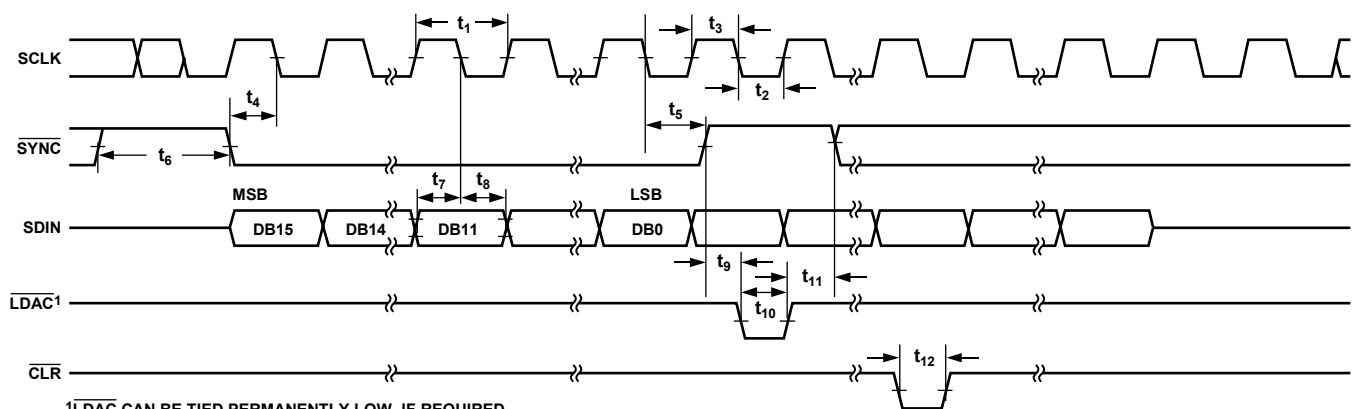

<sup>1</sup>LDAC CAN BE TIED PERMANENTLY LOW, IF REQUIRED.

Figure 2. Timing Diagram for Standalone Mode

# AD5530/AD5531

## DAISY-CHAINING AND READBACK TIMING CHARACTERISTICS

$V_{DD} = 10.8\text{ V to }16.5\text{ V}$ ,  $V_{SS} = -10.8\text{ V to }-16.5\text{ V}$ ;  $GND = 0\text{ V}$ ;  $R_L = 5\text{ k}\Omega$  and  $C_L = 220\text{ pF to GND}$ . All specifications  $T_{MIN}$  to  $T_{MAX}$ , unless otherwise noted.

Table 5.

Parameter <sup>1, 2, 3</sup>	Limit at $T_{MIN}$ , $T_{MAX}$	Unit	Description
$f_{MAX}$	2	MHz max	SCLK frequency
$t_1$	500	ns min	SCLK cycle time
$t_2$	200	ns min	SCLK low time
$t_3$	200	ns min	SCLK high time
$t_4$	50	ns min	$\overline{SYNC}$ to SCLK falling edge setup time
$t_5$	40	ns min	SCLK falling edge to $\overline{SYNC}$ rising edge
$t_6$	50	ns min	Min $\overline{SYNC}$ high time
$t_7$	40	ns min	Data setup time
$t_8$	15	ns min	Data hold time
$t_{12}$	50	ns min	$\overline{CLR}$ pulse width
$t_{13}$	130	ns min	SCLK falling edge to SDO valid
$t_{14}$	50	ns max	SCLK falling edge to SDO invalid
$t_{15}$	50	ns min	$\overline{RBEN}$ to SCLK falling edge setup time
$t_{16}$	50	ns min	$\overline{RBEN}$ hold time
$t_{17}$	100	ns min	$\overline{RBEN}$ falling edge to SDO valid

<sup>1</sup> Guaranteed by design, not subject to production test.

<sup>2</sup> Sample tested during initial release and after any redesign or process change that can affect this parameter. All input signals are measured with  $t_R = t_F = 5\text{ ns}$  (10% to 90% of  $V_{DD}$ ) and timed from a voltage level of  $(V_{IL} + V_{IH})/2$ .

<sup>3</sup> SDO;  $R_{PULLUP} = 5\text{ k}\Omega$ ,  $C_L = 15\text{ pF}$

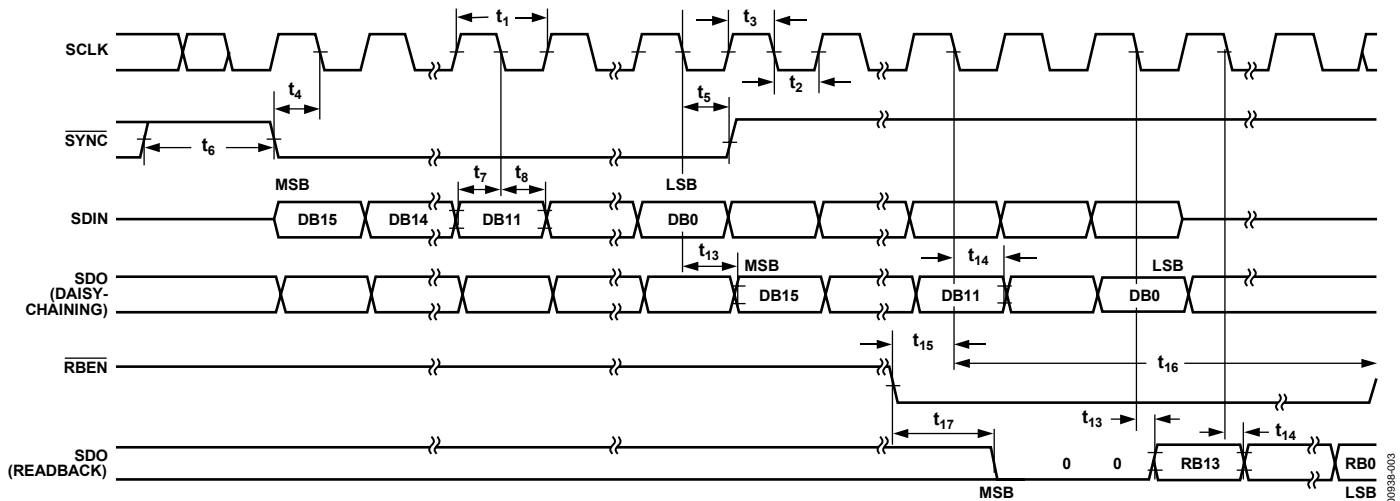

Figure 3. Timing Diagram for Daisy-Chaining and Readback Mode

## ABSOLUTE MAXIMUM RATINGS

$T_A = 25^\circ\text{C}$ , unless otherwise noted.

**Table 6.**

Parameter	Rating
$V_{DD}$ to GND	-0.3 V to +17 V
$V_{SS}$ to GND	+0.3 V to -17 V
Digital Inputs to GND	-0.3 V to $V_{DD} + 0.3$ V
SDO to GND	-0.3 V to +6.5 V
REFIN to REFAGND	-0.3 V to +17 V
REFIN to GND	$V_{SS} - 0.3$ V to $V_{DD} + 0.3$ V
REFAGND to GND	$V_{SS} - 0.3$ V to $V_{DD} + 0.3$ V
DUTGND to GND	$V_{SS} - 0.3$ V to $V_{DD} + 0.3$ V
Operating Temperature Range Industrial (B Version)	-40°C to +85°C
Storage Temperature Range	-65°C to +150°C
Maximum Junction Temperature ( $T_{J\text{MAX}}$ )	150°C
Package Power Dissipation	$(T_{J\text{MAX}} - T_A)/\theta_{JA}$
Thermal Impedance $\theta_{JA}$ TSSOP (RU-16)	150.4°C/W
Lead Temperature (Soldering 10 sec)	300°C
IR Reflow, Peak Temperature (<20 sec)	235°C

Stresses above those listed under Absolute Maximum Ratings may cause permanent damage to the device. This is a stress rating only; functional operation of the device at these or any other conditions above those indicated in the operational section of this specification is not implied. Exposure to absolute maximum rating conditions for extended periods may affect device reliability.

### ESD CAUTION



#### ESD (electrostatic discharge) sensitive device.

Charged devices and circuit boards can discharge without detection. Although this product features patented or proprietary protection circuitry, damage may occur on devices subjected to high energy ESD. Therefore, proper ESD precautions should be taken to avoid performance degradation or loss of functionality.

## PIN CONFIGURATION AND FUNCTION DESCRIPTIONS

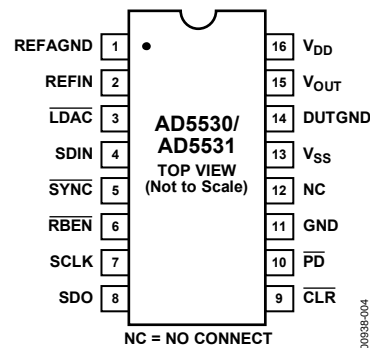

Figure 4. Pin Configuration

Table 7. Pin Function Descriptions

Pin No.	Mnemonic	Description
1	REFAGND	For bipolar $\pm 10$ V output range, this pin should be tied to 0 V.
2	REFIN	This is the voltage reference input for the DAC. Connect to external 5 V reference for specified bipolar $\pm 10$ V output.
3	LDAC	Load DAC Logic Input (Active Low). When taken low, the contents of the shift register are transferred to the DAC register. LDAC can be tied permanently low, enabling the outputs to be updated on the rising edge of SYNC.
4	SDIN	Serial Data Input. This device accepts 16-bit words. Data is clocked into the input register on the falling edge of SCLK.
5	SYNC	Active Low Control Input. Data is clocked into the shift register on the falling edges of SCLK.
6	RBEN	Active Low Readback Enable Function. This function allows the contents of the DAC register to be read. Data from the DAC register is shifted out on the SDO pin on each rising edge of SCLK.
7	SCLK	Clock Input. Data is clocked into the input register on the falling edge of SCLK.
8	SDO	Serial Data Out. This pin is used to clock out the serial data previously written to the input shift register or can be used in conjunction with RBEN to read back the data from the DAC register. This is an open drain output; it should be pulled high with an external pull-up resistor. In standalone mode, SDO should be tied to GND or left high impedance.
9	CLR	Level Sensitive, Active Low Input. A falling edge of CLR resets $V_{OUT}$ to DUTGND. The contents of the registers are untouched.
10	PD	This allows the DAC to be put into a power-down state.
11	GND	Ground Reference.
12	NC	Do not connect anything to this pin.
13	V <sub>SS</sub>	Negative Analog Supply Voltage. $-12\text{ V} \pm 10\%$ or $-15\text{ V} \pm 10\%$ , for specified performance.
14	DUTGND	$V_{OUT}$ is referenced to the voltage applied to this pin.
15	V <sub>OUT</sub>	DAC Output.
16	V <sub>DD</sub>	Positive Analog Supply Voltage. $12\text{ V} \pm 10\%$ or $15\text{ V} \pm 10\%$ , for specified performance.

# TYPICAL PERFORMANCE CHARACTERISTICS

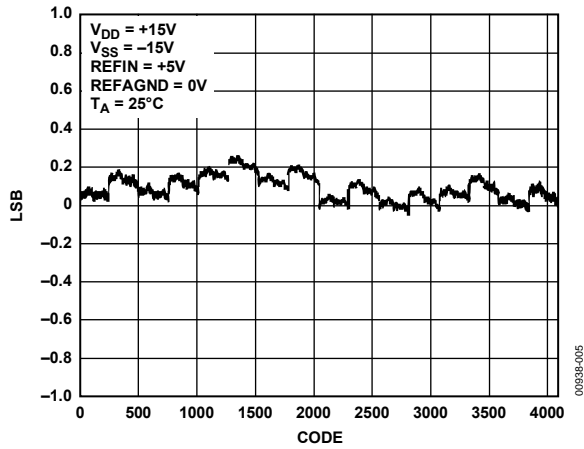

Figure 5. AD5530 Typical INL Plot

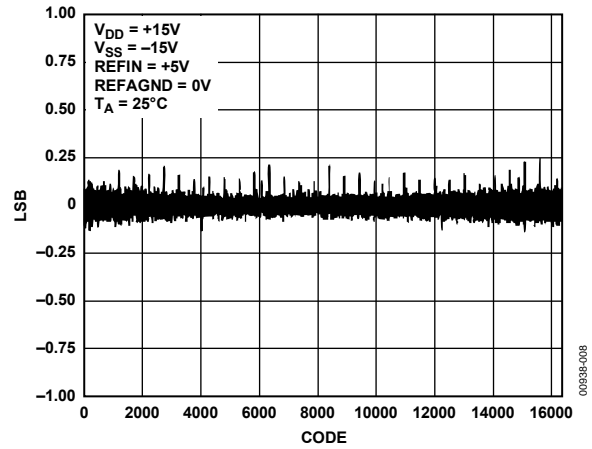

Figure 8. AD5531 Typical DNL Plot

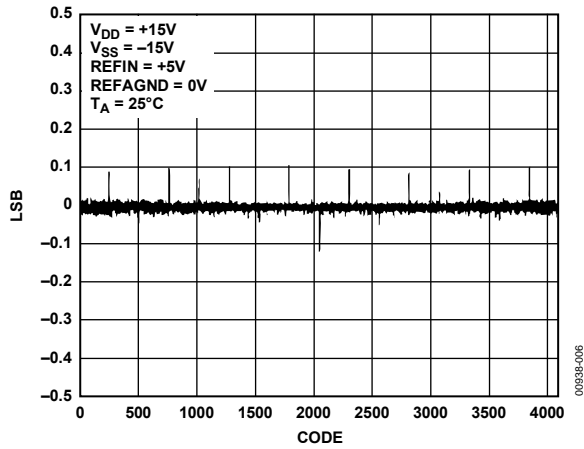

Figure 6. AD5530 Typical DNL Plot

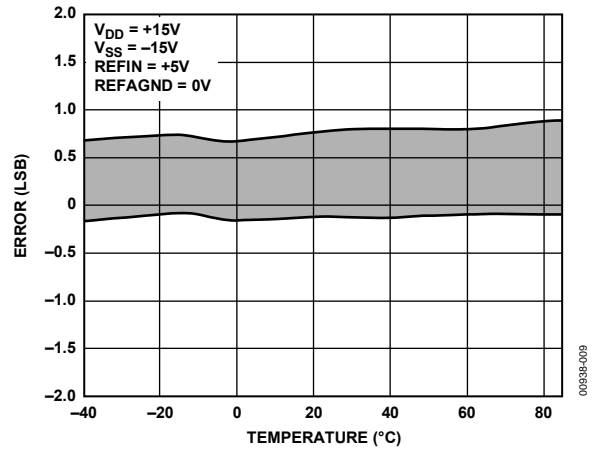

Figure 9. AD5531 Typical INL Error vs. Temperature

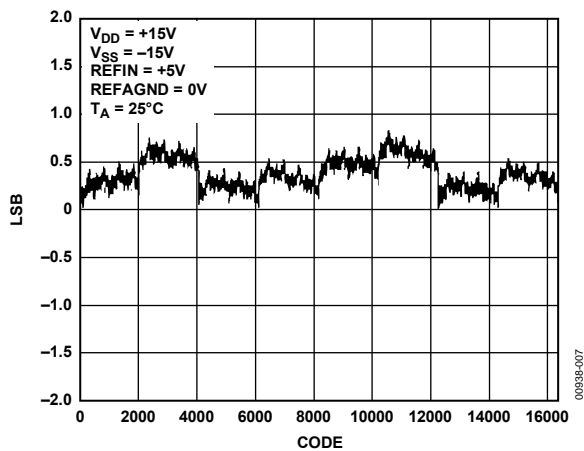

Figure 7. AD5531 Typical INL Plot

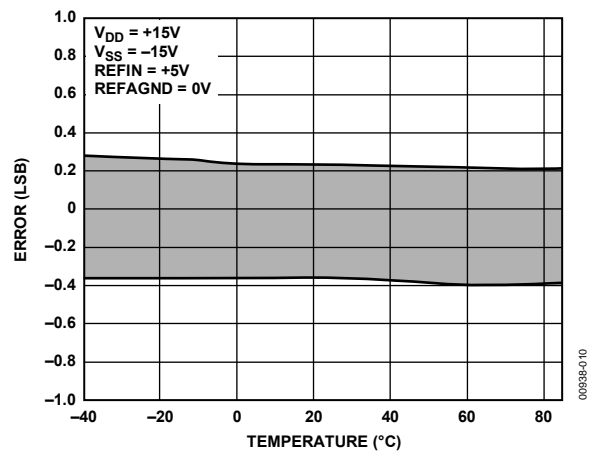

Figure 10. AD5531 Typical DNL Error vs. Temperature

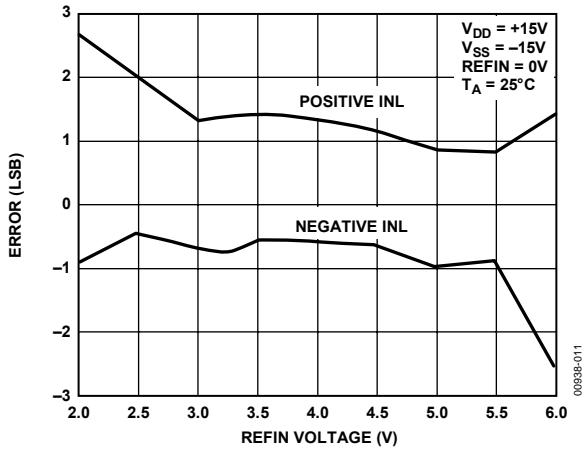

Figure 11. AD5531 Typical INL Error vs. Reference Voltage

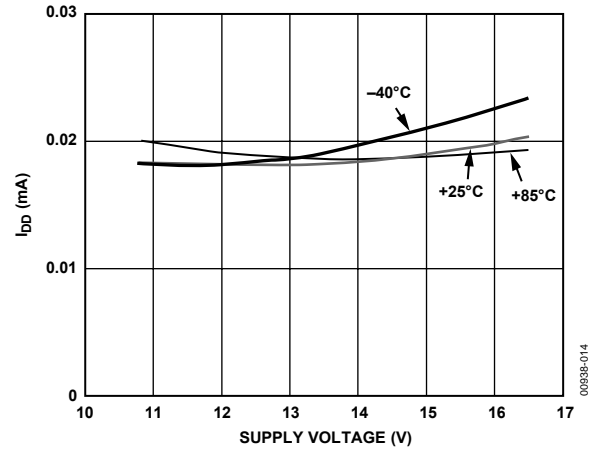

Figure 14.  $I_{DD}$  in Power-Down vs. Supply

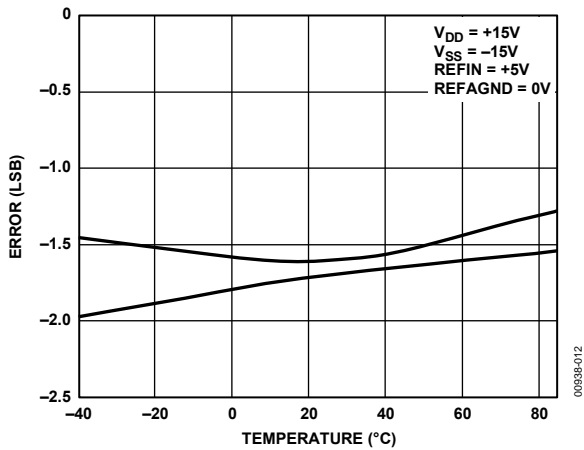

Figure 12. Typical Full-Scale and Offset Error vs. Temperature

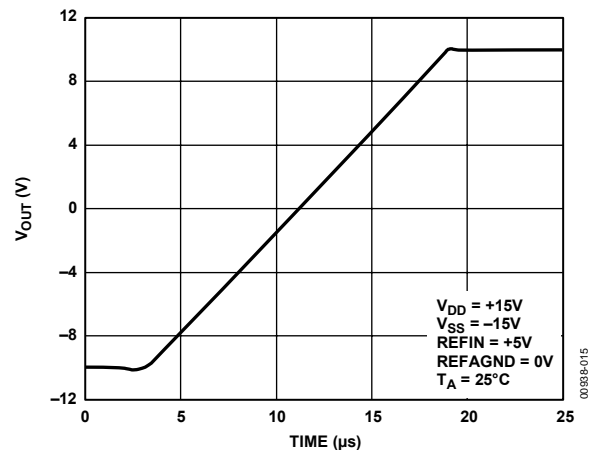

Figure 15. Settling Time

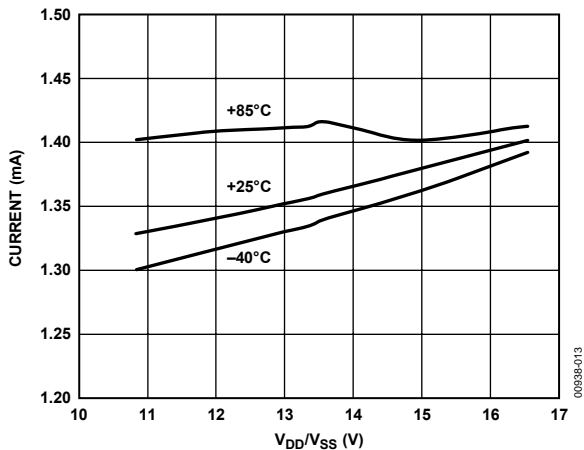

Figure 13.  $I_{DD}$  vs.  $V_{DD}/V_{SS}$

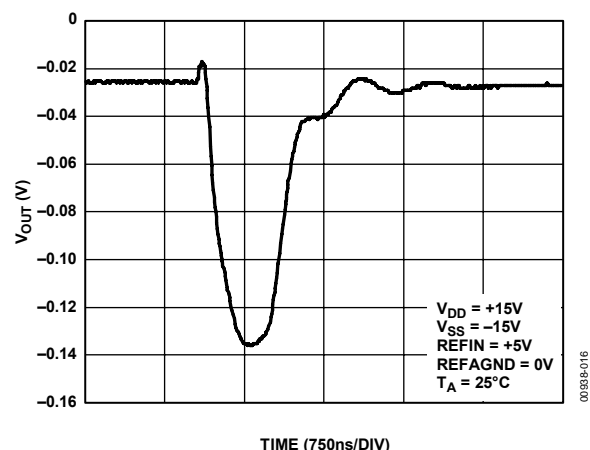

Figure 16. Typical Digital-to-Analog Glitch Impulse

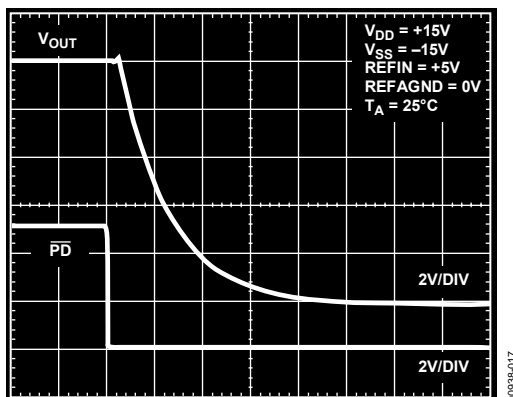

Figure 17. Typical Power-Down Time

## TERMINOLOGY

### Relative Accuracy

Relative accuracy or endpoint linearity is a measure of the maximum deviation, in LSBs, from a straight line passing through the endpoints of the DAC transfer function.

### Differential Nonlinearity

Differential nonlinearity is the difference between the measured change and the ideal 1 LSB change between any two adjacent codes. A specified differential nonlinearity of  $\pm 1$  LSB maximum ensures monotonicity.

### Zero-Scale Error

Zero-scale error is a measure of the output error when all 0s are loaded to the DAC latch.

### Full-Scale Error

This is the error in DAC output voltage when all 1s are loaded into the DAC latch. Ideally the output voltage, with all 1s loaded into the DAC latch, should be  $2 V_{REF} - 1$  LSB.

### Gain Error

Gain error is the difference between the actual and ideal analog output range, expressed as a percent of the full-scale range. It is the deviation in slope of the DAC transfer characteristic from ideal.

### Output Voltage Settling Time

This is the amount of time it takes for the output to settle to a specified level for a full-scale input change.

### Digital-to-Analog Glitch Impulse

Digital-to-analog glitch impulse is the impulse injected into the analog output when the input code in the DAC register changes state. It is specified as the area of the glitch in nV-s and is measured when the digital input code is changed by 1 LSB at the major carry transition.

### Digital Feedthrough

Digital feedthrough is a measure of the impulse injected into the analog output of the DAC from the digital inputs of the DAC, but is measured when the DAC output is not updated. It is specified in nV-s and is measured with a full-scale code change on the data bus, that is, from all 0s to all 1s and vice versa.

## THEORY OF OPERATION

### DAC ARCHITECTURE

The AD5530/AD5531 are pin-compatible 12- and 14-bit DACs. The AD5530 consists of a straight 12-bit R-2R voltage mode DAC, and the AD5531 consists of a 14-bit R-2R section. Using a 5 V reference connected to the REFIN pin and REFAGND tied to 0 V, a bipolar  $\pm 10$  V voltage output results. The DAC coding is straight binary.

### SERIAL INTERFACE

Serial data on the SDIN input is loaded to the input register under the control of SCLK, SYNC, and LDAC. A write operation transfers a 16-bit word to the AD5530/AD5531. Figure 2 and Figure 3 show the timing diagrams. Figure 18 and Figure 19 show the contents of the input shift register. Twelve or 14 bits of the serial word are data bits; the rest are don't cares.

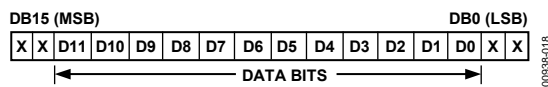

Figure 18. AD5530 Input Shift Register Contents

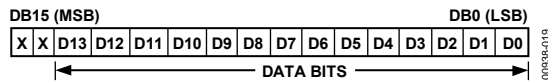

Figure 19. AD5531 Input Shift Register Contents

The serial word is framed by the signal, SYNC. After a high-to-low transition on SYNC, data is latched into the input shift register on the falling edges of SCLK. There are two ways the DAC register and output can be updated. The LDAC signal is examined on the falling edge of SYNC; depending on its status, either a synchronous or asynchronous update is selected. If LDAC is low, then the DAC register and output are updated on the low-to-high transition of SYNC. Alternatively, if LDAC is high upon sampling, the DAC register is not loaded with the new data on a rising edge of SYNC. The contents of the DAC register and the output voltage are updated by bringing LDAC low any time after the 16-bit data transfer is complete. LDAC can be tied permanently low if required. A simplified diagram of the input loading circuitry is illustrated in Figure 20.

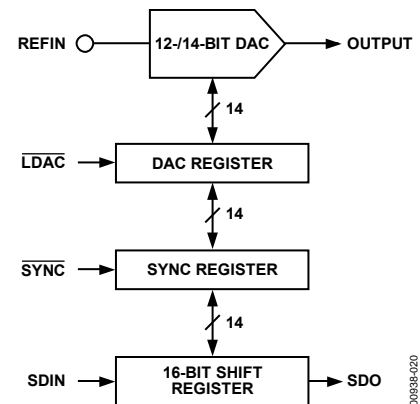

Figure 20. Simplified Serial Interface

Data written to the part via SDIN is available on the SDO pin 16 clocks later if the readback function is not used. SDO data is clocked out on the falling edge of the serial clock with some delay.

### PD FUNCTION

The PD pin allows the user to place the device into power-down mode. While in this mode, power consumption is at a minimum; the device draws only 50  $\mu$ A of current. The PD function does not affect the contents of the DAC register.

### READBACK FUNCTION

The AD5530/AD5531 allows the data contained in the DAC register to be read back if required. The pins involved are the RBEN and SDO (serial data out). When RBEN is taken low, on the next falling edge of SCLK, the contents of the DAC register are transferred to the shift register. RBEN can be used to frame the readback data by leaving it low for 16 clock cycles, or it can be asserted high after the required hold time. The shift register contains the DAC register data and this is shifted out on the SDO line on each falling edge of SCLK with some delay. This ensures the data on the serial data output pin is valid for the falling edge of the receiving part. The two MSBs of the 16-bit word are 0s.

### CLR FUNCTION

The falling edge of CLR causes  $V_{OUT}$  to be reset to the same potential as DUTGND. The contents of the registers remain unchanged, so the user can reload the previous data with LDAC after CLR is asserted high. Alternatively, if LDAC is tied low, the output is loaded with the contents of the DAC register automatically after CLR is brought high.

# AD5530/AD5531

## OUTPUT VOLTAGE

The DAC transfer function is as follows:

$$V_{OUT} = 2 \times [2 \times ((REFIN - REFAGND) \times \frac{D}{2^N}) + 2 \times (REFAGND - REFIN)] - DUTGND$$

where:

$D$  is the decimal data-word loaded to the DAC register.

$N$  is the resolution of the DAC.

## BIPOLAR CONFIGURATION

Figure 21 shows the AD5530/AD5531 in a bipolar circuit configuration. REFIN is driven by the AD586, 5 V reference, and the REFAGND and DUTGND pins are tied to GND. This results in a bipolar output voltage ranging from -10 V to +10 V. Resistor R1 is provided (if required) for gain adjust. Figure 22 shows the transfer function of the DAC when REFAGND is tied to 0 V.

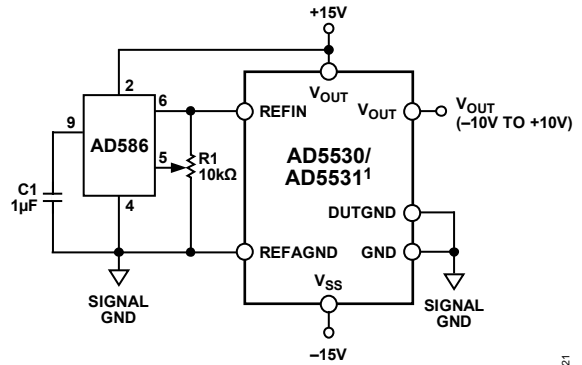

\*ADDITIONAL PINS OMITTED FOR CLARITY.

Figure 21. Bipolar ±10 V Operation

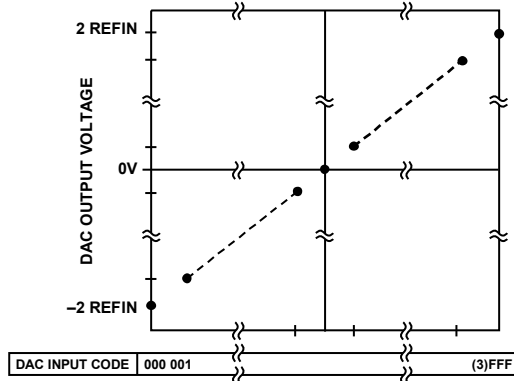

Figure 22. Output Voltage vs. DAC Input Codes (Hex)

## MICROPROCESSOR INTERFACING

Microprocessor interfacing to the AD5530/AD5531 is via a serial bus that uses standard protocol compatible with microcontrollers and DSP processors. The communications channel is a 3-wire (minimum) interface consisting of a clock signal, a data signal, and a synchronization signal. The AD5530/AD5531 requires a 16-bit data-word with data valid on the falling edge of SCLK.

For all the interfaces, the DAC output update can be done automatically when all the data is clocked in or asynchronously under the control of  $\overline{\text{LDAC}}$ .

The contents of the DAC register can be read using the readback function.  $\overline{\text{RBEN}}$  is used to frame the readback data, which is clocked out on SDO. Figure 23, Figure 24, and Figure 25 show these DACs interfacing with a simple 4-wire interface. The serial interface of the AD5530/AD5531 can be operated from a minimum of three wires.

### AD5530/AD5531 TO ADSP-21xx

An interface between the AD5530/AD5531 and the ADSP-21xx is shown in Figure 23. In the interface example shown, SPORT0 is used to transfer data to the DAC. The SPORT control register should be configured as follows: internal clock operation, alternate framing mode; active low framing signal.

Transmission is initiated by writing a word to the Tx register after the SPORT has been enabled. As the data is clocked out of the DSP on the rising edge of SCLK, no glue logic is required to interface the DSP to the DAC. In the interface shown, the DAC output is updated using the  $\overline{\text{LDAC}}$  pin via the DSP. Alternatively, the  $\overline{\text{LDAC}}$  input could be tied permanently low and then the update takes place automatically when TFS is taken high.

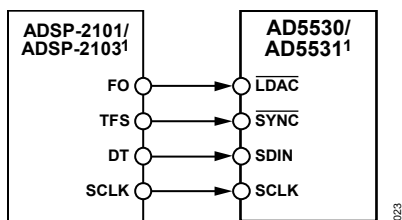

<sup>1</sup>ADDITIONAL PINS OMITTED FOR CLARITY.

Figure 23. AD5530/AD5531 to ADSP-21xx Interface

### AD5530/AD5531 TO 8051 INTERFACE

A serial interface between the AD5530/AD5531 and the 8051 is shown in Figure 24. TxD of the 8051 drives SCLK of the AD5530/AD5531, while RxD drives the serial data line, SDIN. P3.3 and P3.4 are bit-programmable pins on the serial port and are used to drive SYNC and  $\overline{\text{LDAC}}$ , respectively.

The 8051 provides the LSB of its SBUF register as the first bit in the data stream. The user has to ensure that the data in the SBUF register is arranged correctly because the DAC expects MSB first.

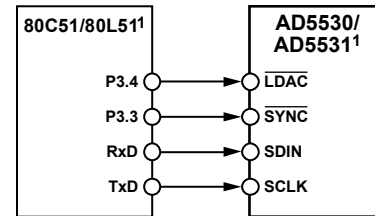

<sup>1</sup>ADDITIONAL PINS OMITTED FOR CLARITY.

Figure 24. AD5530/AD5531 to 8051 Interface

When data is to be transmitted to the DAC, P3.3 is taken low. Data on RxD is clocked out of the microcontroller on the rising edge of TxD and is valid on the falling edge. As a result no glue logic is required between this DAC and microcontroller interface.

The 8051 transmits data in 8-bit bytes with only eight falling clock edges occurring in the transmit cycle. As the DAC expects a 16-bit word, P3.3 must be left low after the first 8 bits are transferred. After the second byte has been transferred, the P3.3 line is taken high. The DAC can be updated using  $\overline{\text{LDAC}}$  via P3.4 of the 8051.

### AD5530/AD5531 TO MC68HC11 INTERFACE

Figure 25 shows an example of a serial interface between the AD5530/AD5531 and the MC68HC11 microcontroller. SCK of the MC68HC11 drives the SCLK of the DAC, and the MOSI output drives the serial data lines, SDIN.  $\overline{\text{SYNC}}$  is driven from one of the port lines, in this case PC7.

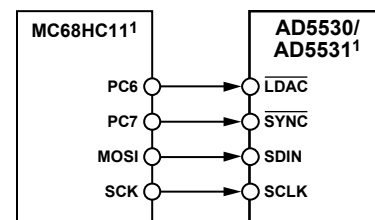

<sup>1</sup>ADDITIONAL PINS OMITTED FOR CLARITY.

Figure 25. AD5530/AD5531 to MC68HC11 Interface

The MC68HC11 is configured for master mode, MSTR = 1, CPOL = 0, and CPHA = 1. When data is transferred to the part, PC7 is taken low and data is transmitted MSB first. Data appearing on the MOSI output is valid on the falling edge of SCK. Eight falling clock edges occur in the transmit cycle, so to load the required 16-bit word, PC7 is not brought high until the second 8-bit word has been transferred to the DAC input shift register.

## AD5530/AD5531

$\overline{\text{LDAC}}$  is controlled by the PC6 port output. The DAC can be updated after each 2-byte transfer by bringing  $\overline{\text{LDAC}}$  low. This example does not show other serial lines for the DAC. If  $\overline{\text{CLR}}$  were used, it could be controlled by port output PC5. To read

data back from the DAC register, the SDO line can be connected to MISO of the MC68HC11, with  $\overline{\text{RBEN}}$  tied to another port output controlling and framing the readback data transfer.

## APPLICATIONS INFORMATION

### OPTOCOUPLER INTERFACE

In many process control applications, it is necessary to provide an isolation barrier between the controller and the unit being controlled. Opto-isolators can provide voltage isolation in excess of 3 kV. The serial loading structure of the AD5530/AD5531 makes it ideal for opto-isolated interfaces because the number of interface lines is kept to a minimum. Figure 26 shows a 4-channel isolated interface to the AD5530/AD5531. To reduce the number of opto-isolators, if simultaneous updating is not required, then the  $\overline{\text{LDAC}}$  pin can be tied permanently low.

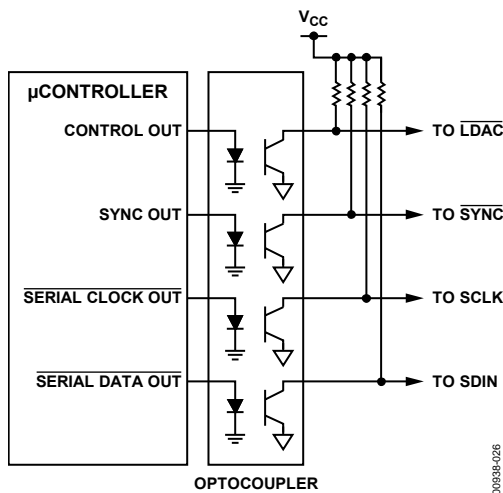

Figure 26. Opto-Isolated Interface

### SERIAL INTERFACE TO MULTIPLE AD5530s OR AD5531s

Figure 27 shows how the  $\overline{\text{SYNC}}$  pin is used to address multiple AD5530/AD5531s. All devices receive the same serial clock and serial data, but only one device receives the  $\overline{\text{SYNC}}$  signal at any one time. The DAC addressed is determined by the decoder. There is some feedthrough from the digital input lines, the effects of which can be minimized by using a burst clock.

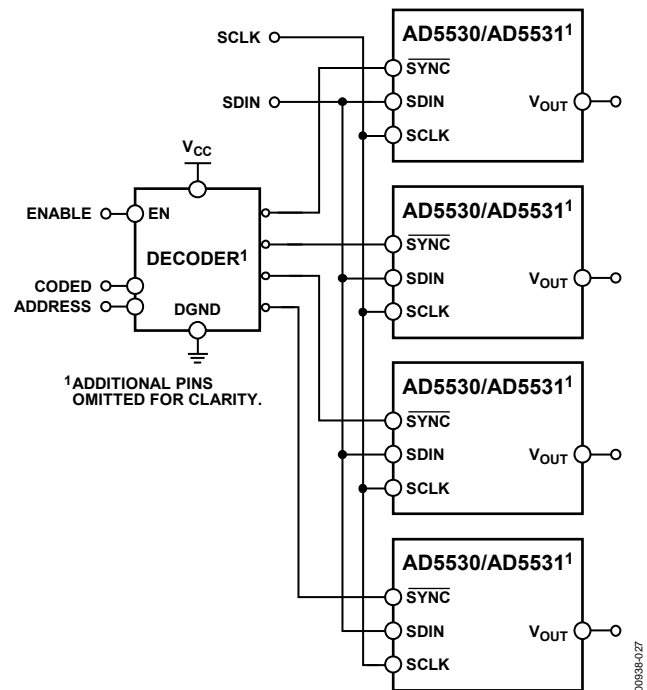

Figure 27. Addressing Multiple AD5530/AD5531s

### DAISY-CHAINING INTERFACE WITH MULTIPLE AD5530s OR AD5531s

A number of these DAC parts can be daisy-chained together using the SDO pin. Figure 28 illustrates such a configuration.

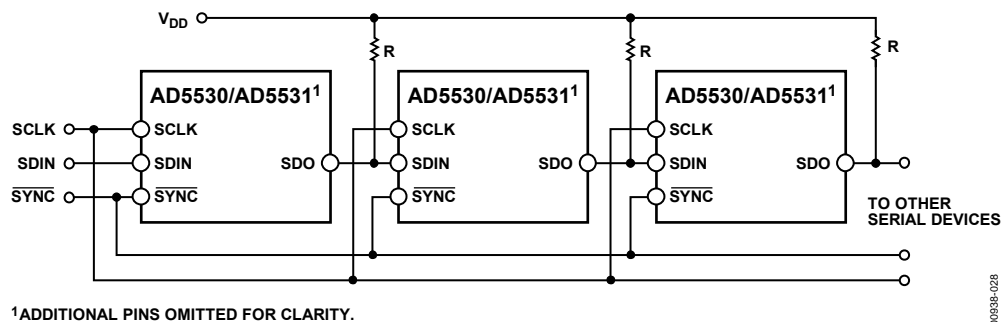
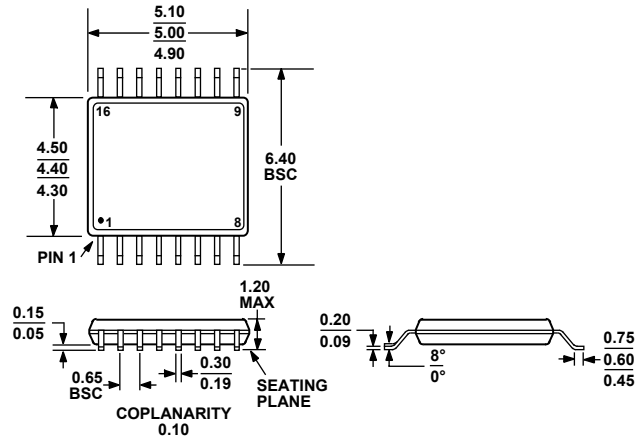

Figure 28. Daisy-Chaining Multiple AD5530/AD5531s

# AD5530/AD5531

## OUTLINE DIMENSIONS



COMPLIANT TO JEDEC STANDARDS MO-153-AB

Figure 29. 16-Lead Thin Shrink Small Outline Package (TSSOP)  
(RU-16)

Dimensions shown in millimeters

## ORDERING GUIDE

Model	Temperature Range	Resolution	INL (LSBs)	DNL (LSBs)	Package Description	Package Option
AD5530BRU	-40°C to +85°C	12	±1	±1	16-Lead TSSOP	RU-16
AD5530BRU-REEL	-40°C to +85°C	12	±1	±1	16-Lead TSSOP	RU-16
AD5530BRU-REEL7	-40°C to +85°C	12	±1	±1	16-Lead TSSOP	RU-16
AD5530BRUZ <sup>1</sup>	-40°C to +85°C	12	±1	±1	16-Lead TSSOP	RU-16
AD5530BRUZ-REEL <sup>1</sup>	-40°C to +85°C	12	±1	±1	16-Lead TSSOP	RU-16
AD5530BRUZ-REEL7 <sup>1</sup>	-40°C to +85°C	12	±1	±1	16-Lead TSSOP	RU-16
AD5531BRU	-40°C to +85°C	14	±2	±1	16-Lead TSSOP	RU-16
AD5531BRU-REEL	-40°C to +85°C	14	±2	±1	16-Lead TSSOP	RU-16
AD5531BRU-REEL7	-40°C to +85°C	14	±2	±1	16-Lead TSSOP	RU-16
AD5531BRUZ <sup>1</sup>	-40°C to +85°C	14	±2	±1	16-Lead TSSOP	RU-16
AD5531BRUZ-REEL <sup>1</sup>	-40°C to +85°C	14	±2	±1	16-Lead TSSOP	RU-16
AD5531BRUZ-REEL7 <sup>1</sup>	-40°C to +85°C	14	±2	±1	16-Lead TSSOP	RU-16

<sup>1</sup> Z = Pb-free part.

**NOTES**

**NOTES**

## Looking for pricing, stock, or lifecycle information?

Click below to explore more details on WIN SOURCE:

 [View AD5531BRUZ on WIN SOURCE](#)

 [Analog Devices Inc. Information](#)

## Optimize Your Supply Chain with WIN SOURCE Solutions

-  Global Sourcing Solution
-  Obsolete Management
-  Cost Control Management
-  Shortage Management
-  Alternative Solution
-  Excess Inventory Management