

FEATURES

- Linear current output: 1 $\mu\text{A}/\text{K}$
- Wide temperature range: -55°C to $+150^\circ\text{C}$
- Probe-compatible ceramic sensor package
- 2-terminal device: voltage in/current out
- Laser trimmed to $\pm 0.5^\circ\text{C}$ calibration accuracy (AD590M)
- Excellent linearity: $\pm 0.3^\circ\text{C}$ over full range (AD590M)
- Wide power supply range: 4 V to 30 V
- Sensor isolation from case
- Available in 2-lead FLATPACK, 4-lead LFCSP, 3-pin TO-52, 8-lead SOIC, and die form

GENERAL DESCRIPTION

The AD590 is a 2-terminal integrated circuit temperature transducer that produces an output current proportional to absolute temperature. For supply voltages between 4 V and 30 V, the device acts as a high impedance, constant current regulator passing 1 $\mu\text{A}/\text{K}$. Laser trimming of the chip's thin-film resistors is used to calibrate the device to 298.2 μA output at 298.2 K (25°C).

The AD590 should be used in any temperature-sensing application below 150°C in which conventional electrical temperature sensors are currently employed. The inherent low cost of a monolithic integrated circuit combined with the elimination of support circuitry makes the AD590 an attractive alternative for many temperature measurement situations. Linearization circuitry, precision voltage amplifiers, resistance measuring circuitry, and cold junction compensation are not needed in applying the AD590.

In addition to temperature measurement, applications include temperature compensation or correction of discrete components, biasing proportional to absolute temperature, flow rate measurement, level detection of fluids and anemometry. The AD590 is available in die form, making it suitable for hybrid circuits and fast temperature measurements in protected environments.

The AD590 is particularly useful in remote sensing applications. The device is insensitive to voltage drops over long lines due to its high impedance current output. Any well-insulated twisted pair is sufficient for operation at hundreds of feet from the receiving circuitry. The output characteristics also make the AD590 easy to multiplex: the current can be switched by a CMOS multiplexer, or the supply voltage can be switched by a logic gate output.

PIN CONFIGURATIONS

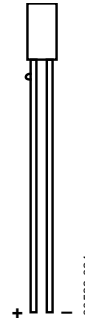
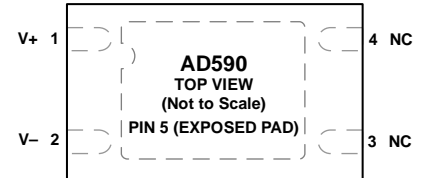

Figure 1. 2-Lead FLATPACK



- NOTES
1. NC = NO CONNECT. THE NC PIN IS NOT BONDED TO THE DIE INTERNALLY.
 2. TO ENSURE CORRECT OPERATION, THE EXPOSED PAD (EP) SHOULD BE LEFT FLOATING.

Figure 2. 4-Lead LFCSP

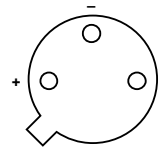

Figure 3. 3-Pin TO-52

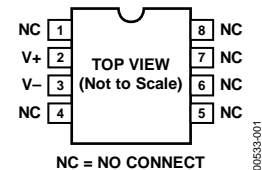

Figure 4. 8-Lead SOIC

PRODUCT HIGHLIGHTS

1. The AD590 is a calibrated, 2-terminal temperature sensor requiring only a dc voltage supply (4 V to 30 V). Costly transmitters, filters, lead wire compensation, and linearization circuits are all unnecessary in applying the device.
2. State-of-the-art laser trimming at the wafer level in conjunction with extensive final testing ensures that AD590 units are easily interchangeable.
3. Superior interface rejection occurs because the output is a current rather than a voltage. In addition, power requirements are low (1.5 mW @ 5 V @ 25°C). These features make the AD590 easy to apply as a remote sensor.
4. The high output impedance ($>10\text{ M}\Omega$) provides excellent rejection of supply voltage drift. For instance, changing the power supply from 5 V to 10 V results in only a 1 μA maximum current change, or 1°C equivalent error.
5. The AD590 is electrically durable: it withstands a forward voltage of up to 44 V and a reverse voltage of 20 V. Therefore, supply irregularities or pin reversal does not damage the device.

TABLE OF CONTENTS

Features	1
General Description	1
Pin Configurations	1
Product Highlights	1
Revision History	2
Specifications	3
AD590J and AD590K Specifications	3
AD590L and AD590M Specifications	4
Absolute Maximum Ratings	5
ESD Caution	5
Product Description	6

REVISION HISTORY

1/13—Rev. F to Rev. G

Changes to Endnote 2, Table 1	3
Changes to Ordering Guide	15

11/12—Rev. E to Rev. F

Added 4-Lead LFCSP_WD	Universal
Changes to Features Section, General Description Section, and Product Highlights Section	1
Added Figure 2; Renumbered Sequentially	1
Added Note 2, Table 1; Renumbered Sequentially	3
Changes to (Unbolded) For 8-Lead SOIC Package, AD590J and AD590K Parameter, Table 1	3
Changes to Note 1, Table 3	5
Changes to Product Description Section	6
Change to Figure 6	6
Changes to Explanation of Temperature Sensor Specifications Section	7
Moved Nonlinearity Section	8
Change to Figure 13	8
Changes to General Applications Section	10
Changes to Figure 17 and Figure 19	10

Explanation of Temperature Sensor Specifications	7
Calibration Error	7
Error vs. Temperature: Calibration Error Trimmed Out	7
Error vs. Temperature: No User Trims	7
Nonlinearity	8
Voltage and Thermal Environment Effects	8
General Applications	10
Outline Dimensions	13
Ordering Guide	15

Deleted Figure 22; Renumbered Sequentially	11
Changes to Figure 21 and Figure 22	11
Deleted Figure 24	12
Changes to Figure 24	12
Updated Outline Dimensions Section	14
Changes to Ordering Guide	14

9/09—Rev. D to Rev. E

Changes to Product Description Section	6
Updated Outline Dimensions	13
Changes to Ordering Guide	14

1/06—Rev. C to Rev. D

Updated Format	Universal
Changes to Figure 4 Equation	4

9/03—Rev. B to Rev. C

Added SOIC-8 Package	Universal
Change to Figure 1	1
Updated Outline Dimensions	13
Added Ordering Guide	14

SPECIFICATIONS

AD590J AND AD590K SPECIFICATIONS

25°C and $V_s = 5\text{ V}$, unless otherwise noted.¹

Table 1.

Parameter	AD590J ²			AD590K			Unit
	Min	Typ	Max	Min	Typ	Max	
POWER SUPPLY							
Operating Voltage Range	4		30	4		30	V
OUTPUT							
Nominal Current Output @ 25°C (298.2 K)		298.2			298.2		μA
Nominal Temperature Coefficient		1			1		μA/K
Calibration Error @ 25°C			±5.0			±2.5	°C
Absolute Error (Over Rated Performance Temperature Range)							
Without External Calibration Adjustment			±10			±5.5	°C
With 25°C Calibration Error Set to Zero			±3.0			±2.0	°C
Nonlinearity							
For TO-52 and FLATPACK Packages			±1.5			±0.8	°C
For 8-Lead SOIC Package			±1.5			±1.0	°C
For 4-Lead LFCSP Package			±1.5				°C
Repeatability ³			±0.1			±0.1	°C
Long-Term Drift ⁴			±0.1			±0.1	°C
Current Noise		40			40		pA/√Hz
Power Supply Rejection							
4 V ≤ V_s ≤ 5 V		0.5			0.5		μA/V
5 V ≤ V_s ≤ 15 V		0.2			0.2		μV/V
15 V ≤ V_s ≤ 30 V		0.1			0.1		μA/V
Case Isolation to Either Lead		10 ¹⁰			10 ¹⁰		Ω
Effective Shunt Capacitance		100			100		pF
Electrical Turn-On Time		20			20		μs
Reverse Bias Leakage Current (Reverse Voltage = 10 V) ⁵		10			10		pA

¹ Specifications shown in **boldface** are tested on all production units at final electrical test. Results from those tests are used to calculate outgoing quality levels. All minimum and maximum specifications are guaranteed, although only those shown in **boldface** are tested on all production units.

² The LFCSP package has a reduced operating temperature range of -40°C to +125°C.

³ Maximum deviation between +25°C readings after temperature cycling between -55°C and +150°C; guaranteed, not tested.

⁴ Conditions: constant 5 V, constant 125°C; guaranteed, not tested.

⁵ Leakage current doubles every 10°C.

AD590L AND AD590M SPECIFICATIONS

25°C and $V_S = 5\text{ V}$, unless otherwise noted.¹

Table 2.

Parameter	AD590L			AD590M			Unit
	Min	Typ	Max	Min	Typ	Max	
POWER SUPPLY							
Operating Voltage Range	4		30	4		30	V
OUTPUT							
Nominal Current Output @ 25°C (298.2 K)		298.2			298.2		μA
Nominal Temperature Coefficient		1			1		μA/K
Calibration Error @ 25°C			±1.0			±0.5	°C
Absolute Error (Over Rated Performance Temperature Range)							°C
Without External Calibration Adjustment			±3.0			±1.7	°C
With ± 25°C Calibration Error Set to Zero			±1.6			±1.0	°C
Nonlinearity			±0.4			±0.3	°C
Repeatability ²			±0.1			±0.1	°C
Long-Term Drift ³			±0.1			±0.1	°C
Current Noise		40			40		pA/√Hz
Power Supply Rejection							
4 V ≤ V_S ≤ 5 V		0.5			0.5		μA/V
5 V ≤ V_S ≤ 15 V		0.2			0.2		μA/V
15 V ≤ V_S ≤ 30 V		0.1			0.1		μA/V
Case Isolation to Either Lead		10 ¹⁰			10 ¹⁰		Ω
Effective Shunt Capacitance		100			100		pF
Electrical Turn-On Time		20			20		μs
Reverse Bias Leakage Current (Reverse Voltage = 10 V) ⁴		10			10		pA

¹ Specifications shown in **boldface** are tested on all production units at final electrical test. Results from those tests are used to calculate outgoing quality levels. All minimum and maximum specifications are guaranteed, although only those shown in **boldface** are tested on all production units.

² Maximum deviation between +25°C readings after temperature cycling between -55°C and +150°C; guaranteed, not tested.

³ Conditions: constant 5 V, constant 125°C; guaranteed, not tested.

⁴ Leakage current doubles every 10°C.

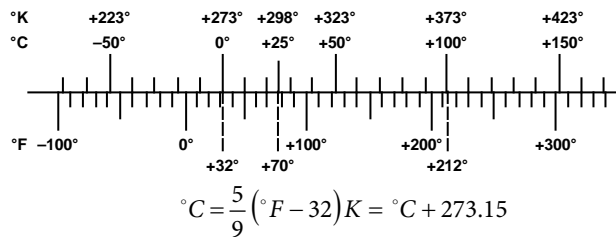

Figure 5. Temperature Scale Conversion Equations

ABSOLUTE MAXIMUM RATINGS

Table 3.

Parameter	Rating
Forward Voltage (E+ or E-)	44 V
Reverse Voltage (E+ to E-)	-20 V
Breakdown Voltage (Case E+ or E-)	±200 V
Rated Performance Temperature Range ¹	-55°C to +150°C
Storage Temperature Range ¹	-65°C to +155°C
Lead Temperature (Soldering, 10 sec)	300°C

¹ The AD590 was used at -100°C and +200°C for short periods of measurement with no physical damage to the device. However, the absolute errors specified apply to only the rated performance temperature range. Applicable to 2-lead FLATPACK and 3-pin TO-52 packages only.

Stresses above those listed under Absolute Maximum Ratings may cause permanent damage to the device. This is a stress rating only and functional operation of the device at these or any other conditions above those indicated in the operational section of this specification is not implied. Exposure to absolute maximum rating conditions for extended periods may affect device reliability.

ESD CAUTION



ESD (electrostatic discharge) sensitive device. Charged devices and circuit boards can discharge without detection. Although this product features patented or proprietary protection circuitry, damage may occur on devices subjected to high energy ESD. Therefore, proper ESD precautions should be taken to avoid performance degradation or loss of functionality.

PRODUCT DESCRIPTION

The AD590 is a 2-terminal temperature-to-voltage transducer. It is available in a variety of accuracy grades and packages. When using the AD590 in die form, the chip substrate must be kept electrically isolated (floating) for correct circuit operation.

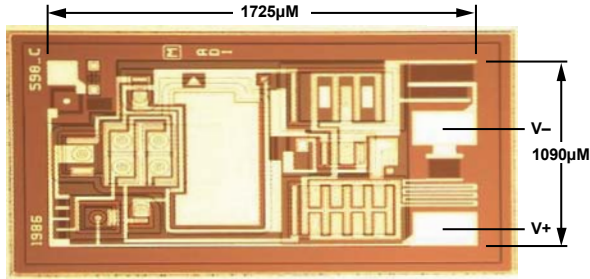

Figure 6. Metallization Diagram

The AD590 uses a fundamental property of the silicon transistors from which it is made to realize its temperature proportional characteristic: if two identical transistors are operated at a constant ratio of collector current densities, r , then the difference in their base-emitter voltage is $(kT/q)(\ln r)$. Because both k (Boltzman's constant) and q (the charge of an electron) are constant, the resulting voltage is directly proportional to absolute temperature (PTAT). (For a more detailed description, see M.P. Timko, "A Two-Terminal IC Temperature Transducer," IEEE J. Solid State Circuits, Vol. SC-11, p. 784-788, Dec. 1976. Understanding the Specifications-AD590.)

In the AD590, this PTAT voltage is converted to a PTAT current by low temperature coefficient thin-film resistors. The total current of the device is then forced to be a multiple of this PTAT current. Figure 7 is the schematic diagram of the AD590. In this figure, Q8 and Q11 are the transistors that produce the PTAT voltage. R5 and R6 convert the voltage to current. Q10, whose collector current tracks the collector currents in Q9 and Q11, supplies all the bias and substrate leakage current for the rest of the circuit, forcing the total current to be PTAT. R5 and R6 are laser-trimmed on the wafer to calibrate the device at 25°C.

Figure 8 shows the typical V-I characteristic of the circuit at 25°C and the temperature extremes.

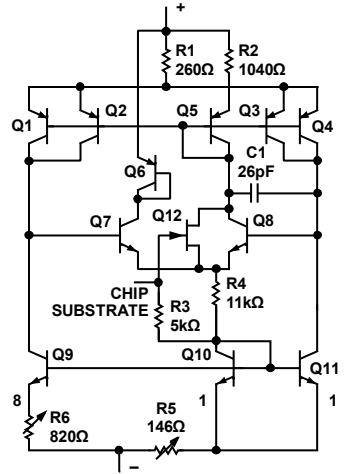

Figure 7. Schematic Diagram

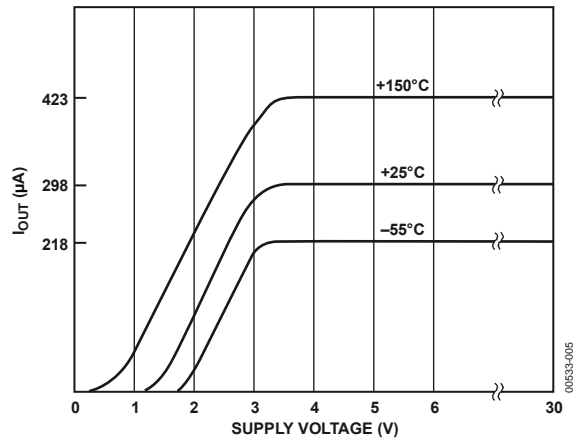

Figure 8. V-I Plot

EXPLANATION OF TEMPERATURE SENSOR SPECIFICATIONS

The way in which the AD590 is specified makes it easy to apply it in a wide variety of applications. It is important to understand the meaning of the various specifications and the effects of the supply voltage and thermal environment on accuracy.

The AD590 is a PTAT current regulator. (Note that $T (^{\circ}\text{C}) = T (\text{K}) - 273.2$. Zero on the Kelvin scale is absolute zero; there is no lower temperature.) That is, the output current is equal to a scale factor times the temperature of the sensor in degrees Kelvin. This scale factor is trimmed to $1 \mu\text{A}/\text{K}$ at the factory, by adjusting the indicated temperature (that is, the output current) to agree with the actual temperature. This is done with 5 V across the device at a temperature within a few degrees of 25°C (298.2 K). The device is then packaged and tested for accuracy over temperature.

CALIBRATION ERROR

At final factory test, the difference between the indicated temperature and the actual temperature is called the calibration error. Since this is a scale factory error, its contribution to the total error of the device is PTAT. For example, the effect of the 1°C specified maximum error of the AD590L varies from 0.73°C at -55°C to 1.42°C at 150°C . Figure 9 shows how an exaggerated calibration error would vary from the ideal over temperature.

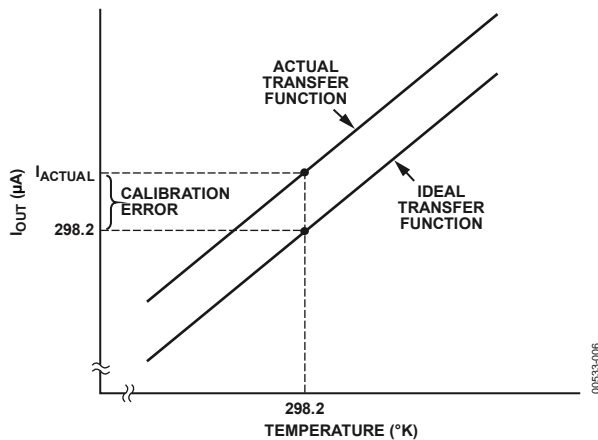

Figure 9. Calibration Error vs. Temperature

The calibration error is a primary contributor to the maximum total error in all AD590 grades. However, because it is a scale factor error, it is particularly easy to trim. Figure 10 shows the most elementary way of accomplishing this.

To trim this circuit, the temperature of the AD590 is measured by a reference temperature sensor and R is trimmed so that $V_T = 1 \text{ mV}/\text{K}$ at that temperature. Note that when this error is trimmed out at one temperature, its effect is zero over the entire

temperature range. In most applications, there is a current-to-voltage conversion resistor (or, as with a current input ADC, a reference) that can be trimmed for scale factor adjustment.

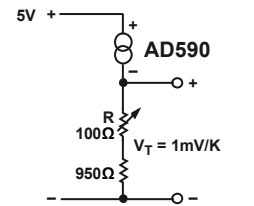

Figure 10. One Temperature Trim

ERROR VS. TEMPERATURE: CALIBRATION ERROR TRIMMED OUT

Each AD590 is tested for error over the temperature range with the calibration error trimmed out. This specification could also be called the variance from PTAT, because it is the maximum difference between the actual current over temperature and a PTAT multiplication of the actual current at 25°C . This error consists of a slope error and some curvature, mostly at the temperature extremes. Figure 11 shows a typical AD590K temperature curve before and after calibration error trimming.

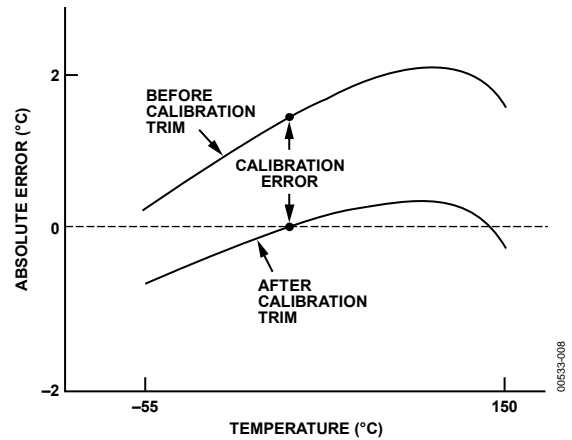

Figure 11. Effect to Scale Factor Trim on Accuracy

ERROR VS. TEMPERATURE: NO USER TRIMS

Using the AD590 by simply measuring the current, the total error is the variance from PTAT, described above, plus the effect of the calibration error over temperature. For example, the AD590L maximum total error varies from 2.33°C at -55°C to 3.02°C at 150°C . For simplicity, only the large figure is shown on the specification page.

NONLINEARITY

Nonlinearity as it applies to the AD590 is the maximum deviation of current over temperature from a best-fit straight line. The nonlinearity of the AD590 over the -55°C to $+150^{\circ}\text{C}$ range is superior to all conventional electrical temperature sensors such as thermocouples, RTDs, and thermistors. Figure 12 shows the nonlinearity of the typical AD590K from Figure 11.

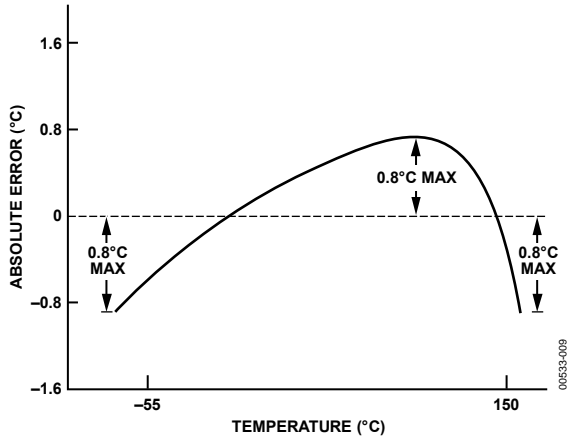

Figure 12. Nonlinearity

Figure 13 shows a circuit in which the nonlinearity is the major contributor to error over temperature. The circuit is trimmed by adjusting R1 for a 0 V output with the AD590 at 0°C . R2 is then adjusted for 10 V output with the sensor at 100°C . Other pairs of temperatures can be used with this procedure as long as they are measured accurately by a reference sensor. Note that for 15 V output (150°C), the $V+$ of the op amp must be greater than 17 V. Also, note that $V-$ should be at least -4 V ; if $V-$ is ground, there is no voltage applied across the device.

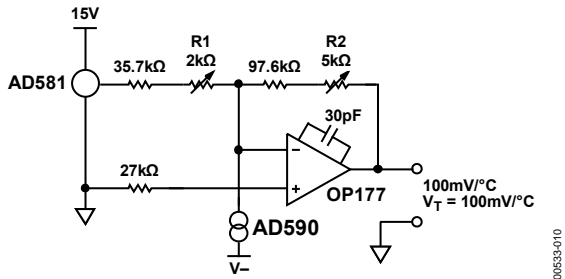

Figure 13. 2-Temperature Trim

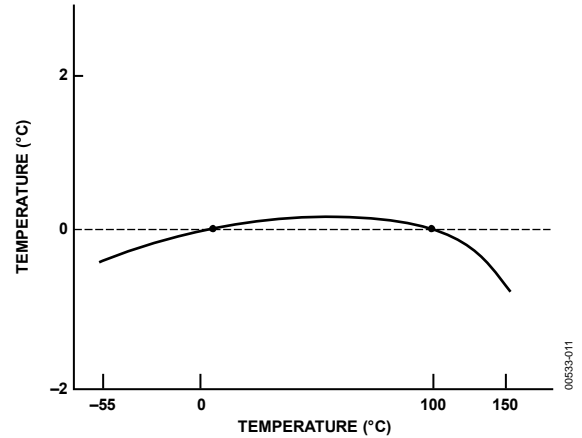

Figure 14. Typical 2-Trim Accuracy

VOLTAGE AND THERMAL ENVIRONMENT EFFECTS

The power supply rejection specifications show the maximum expected change in output current vs. input voltage changes. The insensitivity of the output to input voltage allows the use of unregulated supplies. It also means that hundreds of ohms of resistance (such as a CMOS multiplexer) can be tolerated in series with the device.

It is important to note that using a supply voltage other than 5 V does not change the PTAT nature of the AD590. In other words, this change is equivalent to a calibration error and can be removed by the scale factor trim (see Figure 11).

The AD590 specifications are guaranteed for use in a low thermal resistance environment with 5 V across the sensor. Large changes in the thermal resistance of the sensor's environment change the amount of self-heating and result in changes in the output, which are predictable but not necessarily desirable.

The thermal environment in which the AD590 is used determines two important characteristics: the effect of self-heating and the response of the sensor with time. Figure 15 is a model of the AD590 that demonstrates these characteristics.

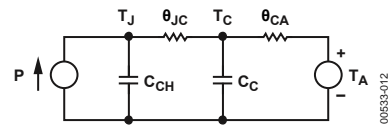

Figure 15. Thermal Circuit Model

As an example, for the TO-52 package, θ_{JC} is the thermal resistance between the chip and the case, about 26°C/W. θ_{CA} is the thermal resistance between the case and the surroundings and is determined by the characteristics of the thermal connection. Power source P represents the power dissipated on the chip. The rise of the junction temperature, T_J , above the ambient temperature, T_A , is

$$T_J - T_A = P(\theta_{JC} + \theta_{CA}) \tag{1}$$

Table 4 gives the sum of θ_{JC} and θ_{CA} for several common thermal media for both the H and F packages. The heat sink used was a common clip-on. Using Equation 1, the temperature rise of an AD590 H package in a stirred bath at 25°C, when driven with a 5 V supply, is 0.06°C. However, for the same conditions in still air, the temperature rise is 0.72°C. For a given supply voltage, the temperature rise varies with the current and is PTAT. Therefore, if an application circuit is trimmed with the sensor in the same thermal environment in which it is used, the scale factor trim compensates for this effect over the entire temperature range.

Table 4. Thermal Resistance

Medium	$\theta_{JC} + \theta_{CA}$ (°C/Watt)		τ (sec) ¹	
	H	F	H	F
Aluminum Block	30	10	0.6	0.1
Stirred Oil ²	42	60	1.4	0.6
Moving Air ³				
With Heat Sink	45	–	5.0	–
Without Heat Sink	115	190	13.5	10.0
Still Air				
With Heat Sink	191	–	108	–
Without Heat Sink	480	650	60	30

¹ τ is dependent upon velocity of oil; average of several velocities listed above.
² Air velocity @ 9 ft/sec.
³ The time constant is defined as the time required to reach 63.2% of an instantaneous temperature change.

The time response of the AD590 to a step change in temperature is determined by the thermal resistances and the thermal capacities of the chip, C_{CH} , and the case, C_C . C_{CH} is about 0.04 Ws/°C for the AD590. C_C varies with the measured medium, because it includes anything that is in direct thermal contact with the case. The single time constant exponential curve of Figure 16 is usually sufficient to describe the time response, $T(t)$. Table 4 shows the effective time constant, τ , for several media.

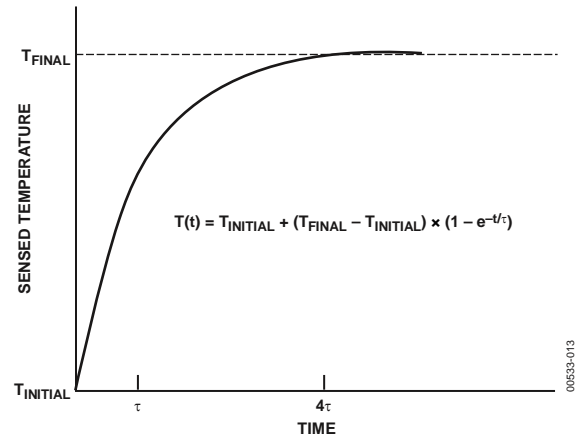

Figure 16. Time Response Curve

GENERAL APPLICATIONS

Figure 17 shows a typical use of the AD590 in a remote temperature sensing application. The AD590 is used as a thermometer circuit that measures temperature from -55°C to $+150^{\circ}\text{C}$, with an output voltage of $1\text{ mV}/^{\circ}\text{K}$. Because the AD590 measures absolute temperature (its nominal output is $1\text{ mA}/\text{K}$), the output must be offset by 273.2 mA to read out in degrees Celsius.

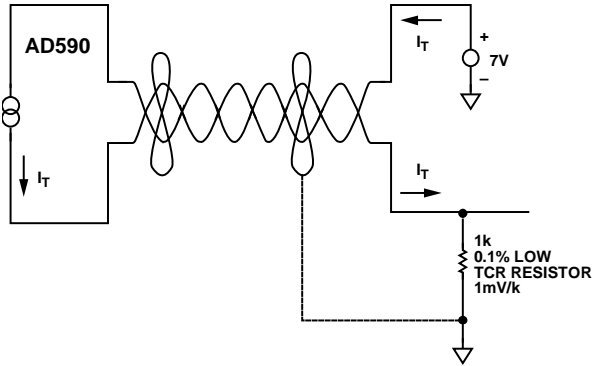

Figure 17. Variable Scale Display

Connecting several AD590 units in series, as shown in Figure 18, allows the minimum of all the sensed temperatures to be indicated. In contrast, using the sensors in parallel yields the average of the sensed temperatures.

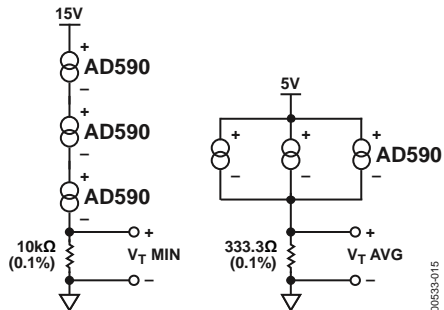

Figure 18. Series and Parallel Connection

The circuit in Figure 19 demonstrates one method by which differential temperature measurements can be made. R1 and R2 can be used to trim the output of the op amp to indicate a desired temperature difference. For example, the inherent offset between the two devices can be trimmed in. If $V+$ and $V-$ are radically different, then the difference in internal dissipation causes a differential internal temperature rise. This effect can be used to measure the ambient thermal resistance seen by the sensors in applications such as fluid-level detectors or anemometry.

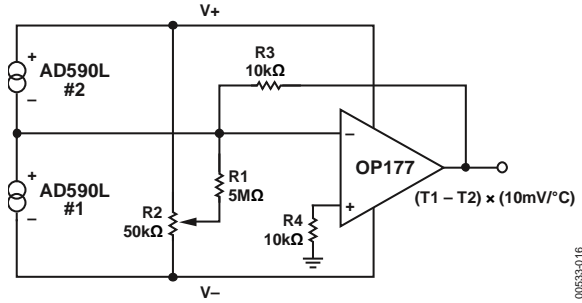

Figure 19. Differential Measurements

Figure 20 is an example of a cold junction compensation circuit for a Type J thermocouple using the AD590 to monitor the reference junction temperature. This circuit replaces an ice-bath as the thermocouple reference for ambient temperatures between 15°C and 35°C . The circuit is calibrated by adjusting R_T for a proper meter reading with the measuring junction at a known reference temperature and the circuit near 25°C . Using components with the TCs as specified in Figure 20, compensation accuracy is within $\pm 0.5^{\circ}\text{C}$ for circuit temperatures between 15°C and 35°C . Other thermocouple types can be accommodated with different resistor values. Note that the TCs of the voltage reference and the resistors are the primary contributors to error.

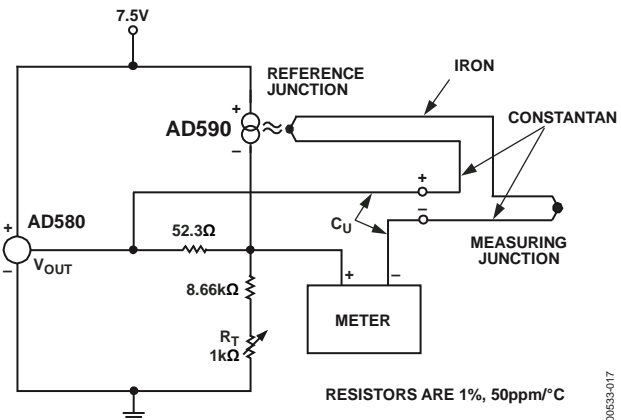

Figure 20. Cold Junction Compensation Circuit for Type J Thermocouple

Figure 21 is an example of a current transmitter designed to be used with 40 V, 1 kΩ systems; it uses its full current range of 4 to 20 mA for a narrow span of measured temperatures. In this example, the 1 μA/K output of the AD590 is amplified to 1 mA/°C and offset so that 4 mA is equivalent to 17°C and 20 mA is equivalent to 33°C. R_T is trimmed for proper reading at an intermediate reference temperature. With a suitable choice of resistors, any temperature range within the operating limits of the AD590 can be chosen.

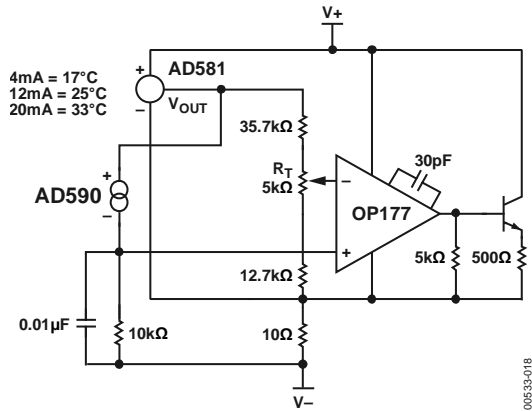

Figure 21. 4 to 20 mA Current Transmitter

Figure 22 is an example of a variable temperature control circuit (thermostat) using the AD590. R_H and R_L are selected to set the high and low limits for R_{SET}. R_{SET} could be a simple pot, a calibrated multiturn pot, or a switched resistive divider. Powering the AD590 from the 10 V reference isolates the AD590 from supply variations while maintaining a reasonable voltage (~7 V) across it. Capacitor C1 is often needed to filter extraneous noise from remote sensors. R_B is determined by the β of the power transistor and the current requirements of the load.

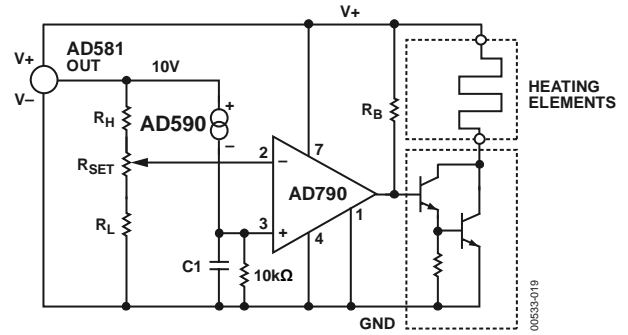

Figure 22. Simple Temperature Control Circuit

The voltage compliance and the reverse blocking characteristic of the AD590 allow it to be powered directly from 5 V CMOS logic. This permits easy multiplexing, switching, or pulsing for minimum internal heat dissipation. In Figure 23, any AD590 connected to a logic high passes a signal current through the current measuring circuitry, while those connected to a logic zero pass insignificant current. The outputs used to drive the AD590s can be employed for other purposes, but the additional capacitance due to the AD590 should be taken into account.

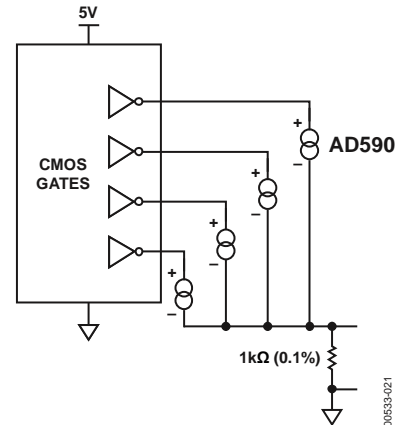

Figure 23. AD590 Driven from CMOS Logic

Figure 24 demonstrates a method of multiplexing the AD590 in the 2-trim mode (see Figure 13 and Figure 14). Additional AD590s and their associated resistors can be added to multiplex up to eight channels of $\pm 0.5^\circ\text{C}$ absolute accuracy over the

temperature range of -55°C to $+125^\circ\text{C}$. The high temperature restriction of 125°C is due to the output range of the op amps; output to 150°C can be achieved by using a 20 V supply for the op amp.

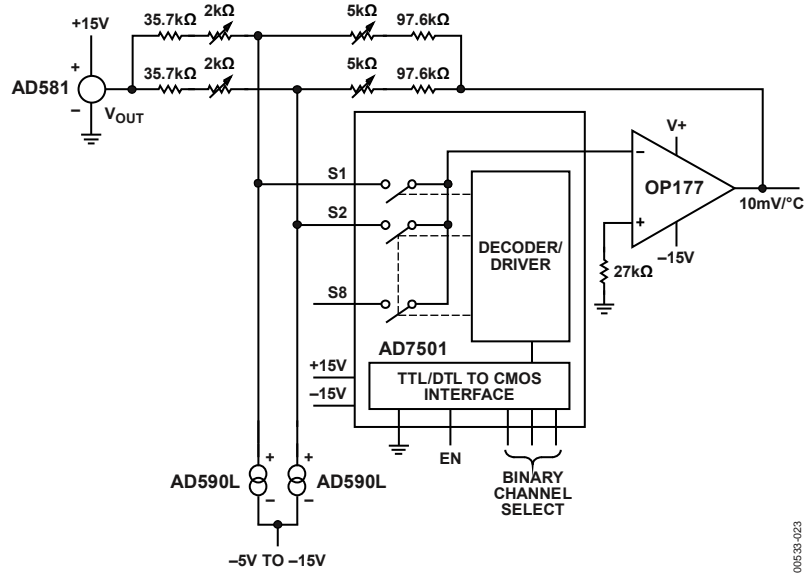

Figure 24. 8-Channel Multiplexer

00533-023

OUTLINE DIMENSIONS

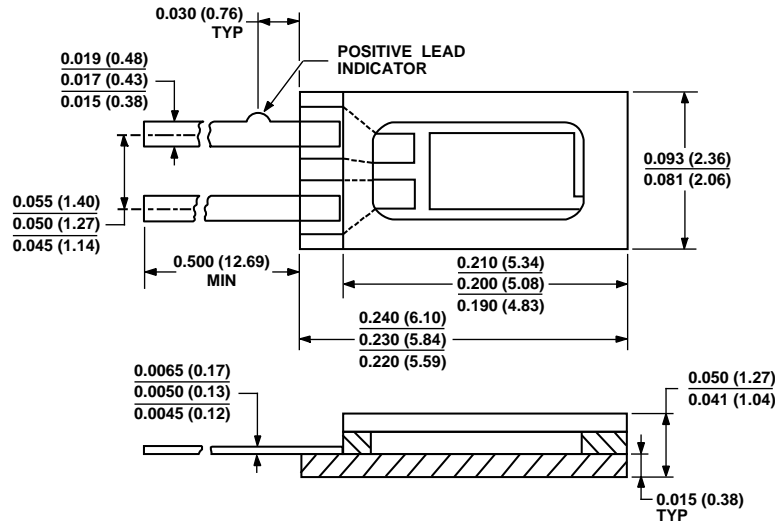
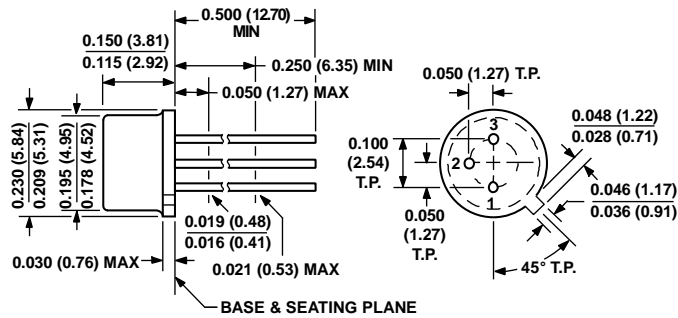

Figure 25. 2-Lead Ceramic Flat Package [FLATPACK] (F-2)
Dimensions shown in inches and (millimeters)



CONTROLLING DIMENSIONS ARE IN INCHES; MILLIMETER DIMENSIONS (IN PARENTHESES) ARE ROUNDED-OFF INCH EQUIVALENTS FOR REFERENCE ONLY AND ARE NOT APPROPRIATE FOR USE IN DESIGN.

Figure 26. 3-Pin Metal Header Package [TO-52] (H-03-1)
Dimensions shown in inches and (millimeters)

02208-A

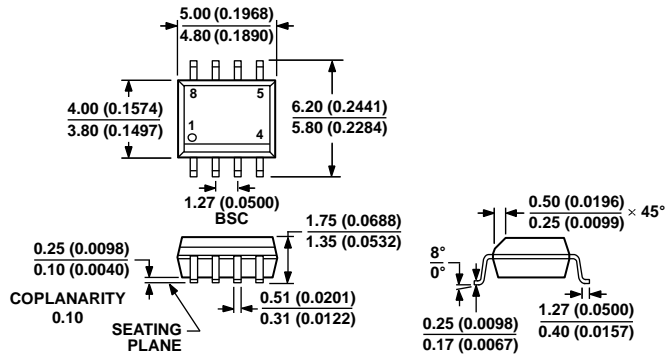

COMPLIANT TO JEDEC STANDARDS MS-012-AA
 CONTROLLING DIMENSIONS ARE IN MILLIMETERS; INCH DIMENSIONS
 (IN PARENTHESES) ARE ROUNDED-OFF MILLIMETER EQUIVALENTS FOR
 REFERENCE ONLY AND ARE NOT APPROPRIATE FOR USE IN DESIGN.

Figure 27. 8-Lead Standard Small Outline Package [SOIC_N]
 Narrow Body
 (R-8)
 Dimensions shown in millimeters and (inches)

012407-A

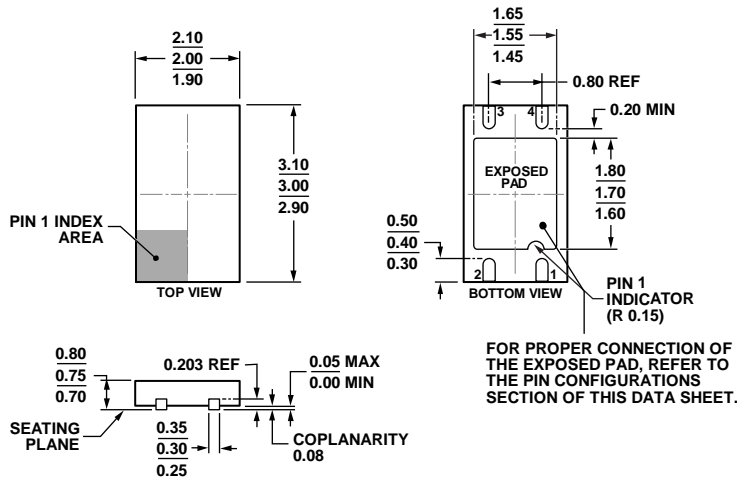

COMPLIANT TO JEDEC STANDARDS MO-229
 Figure 28. 4-Lead Lead Frame Chip Scale Package [LF CSP_WD]
 2.00 mm x 3.00 mm Body, Very Very Thin, Dual Lead
 (CP-4-1)
 Dimensions shown in millimeters

09-07-2010-B

ORDERING GUIDE

Model ^{1, 2}	Temperature Range	Package Description	Package Option	Branding
AD590JF	-55°C to +150°C	2-Lead FLATPACK	F-2	
AD590JH	-55°C to +150°C	3-Pin TO-52	H-03-1	
AD590JR	-55°C to +150°C	8-Lead SOIC_N	R-8	
AD590JRZ	-55°C to +150°C	8-Lead SOIC_N	R-8	
AD590KF	-55°C to +150°C	2-Lead FLATPACK	F-2	
AD590KH	-55°C to +150°C	3-Pin TO-52	H-03-1	
AD590KR	-55°C to +150°C	8-Lead SOIC_N	R-8	
AD590KR-REEL	-55°C to +150°C	8-Lead SOIC_N	R-8	
AD590KRZ	-55°C to +150°C	8-Lead SOIC_N	R-8	
AD590KRZ-RL	-55°C to +150°C	8-Lead SOIC_N	R-8	
AD590LF	-55°C to +150°C	2-Lead FLATPACK	F-2	
AD590LH	-55°C to +150°C	3-Pin TO-52	H-03-1	
AD590MF	-55°C to +150°C	2-Lead FLATPACK	F-2	
AD590MH	-55°C to +150°C	3-Pin TO-52	H-03-1	
AD590JCHIPS	-55°C to +150°C	Bare Die	H-03-1	
AD590JCPZ-R5	-40°C to +125°C	4-Lead LFCSP_WD	CP-4-1	7A
AD590JCPZ-RL7	-40°C to +125°C	4-Lead LFCSP_WD	CP-4-1	7A

¹ Z = RoHS Compliant Part.² The AD590xF models and the AD590xH models are available in 883B.

NOTES

Looking for pricing, stock, or lifecycle information?

Click below to explore more details on WIN SOURCE:

 [View AD590JH/883B on WIN SOURCE](#)

 [Analog Devices Inc. Information](#)

Optimize Your Supply Chain with WIN SOURCE Solutions

-  Global Sourcing Solution
-  Obsolete Management
-  Cost Control Management
-  Shortage Management
-  Alternative Solution
-  Excess Inventory Management