

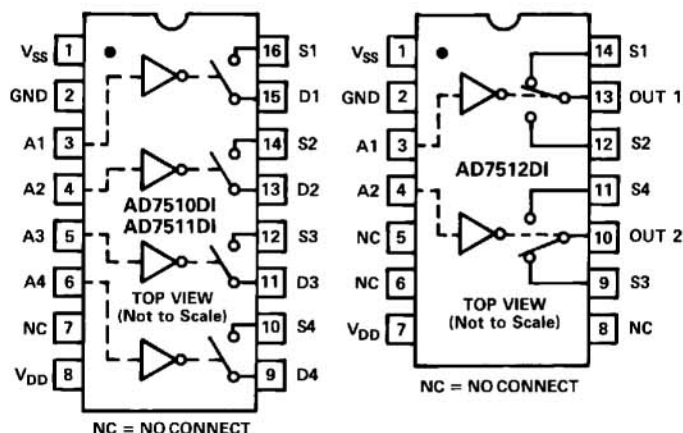

**THE DATASHEET OF
AD7511DIJNZ**



AD7510DI/AD7511DI/AD7512DI
FEATURES
Latch-Proof
Overvoltage-Proof: $\pm 25V$
Low R_{ON} : 75Ω
Low Dissipation: 3mW
TTL/CMOS Direct Interface
Silicon-Nitride Passivated
Monolithic Dielectrically-Isolated CMOS
Standard 14-/16-Pin DIPs and
20-Terminal Surface Mount Packages
DIP FUNCTIONAL DIAGRAMS

GENERAL DESCRIPTION

The AD7510DI, AD7511DI and AD7512DI are a family of latch proof dielectrically isolated CMOS switches featuring overvoltage protection up to $\pm 25V$ above the power supplies. These benefits are obtained without sacrificing the low "ON" resistance (75Ω) or low leakage current ($500pA$), the main features of an analog switch.

The AD7510DI and AD7511DI consist of four independent SPST analog switches packaged in either a 16-pin DIP or a 20-terminal surface mount package. They differ only in that the digital control logic is inverted. The AD7512DI has two independent SPDT switches packaged either in a 14-pin DIP or a 20-terminal surface mount package.

Very low power dissipation, overvoltage protection and TTL/CMOS direct interfacing are achieved by combining a unique circuit design and a dielectrically isolated CMOS process. Silicon nitride passivation ensures long term stability while monolithic construction provides reliability.

CONTROL LOGIC

AD7510DI: Switch "ON" for Address "HIGH"

AD7511DI: Switch "ON" for Address "LOW"

AD7512DI: Address "HIGH" makes S1 to Out 1 and S3 to Out 2

ORDERING GUIDE

Model ¹	Temperature Range	Package Option ²
AD7510DIKN	0 to +70°C	N-16
AD7510DIKP	0 to +70°C	P-20A
AD7510DIKQ	-25°C to +85°C	Q-16
AD7510DISQ	-55°C to +125°C	Q-16
AD7510DISE	-55°C to +125°C	E-20A
AD7511DIKN	0 to +70°C	N-16
AD7511DIKP	0 to +70°C	P-20A
AD7511DIKQ	-25°C to +85°C	Q-16
AD7511DISQ	-55°C to +125°C	Q-16
AD7511DITE	-55°C to +125°C	E-20A
AD7512DIKN	0 to +70°C	N-14
AD7512DIKP	0 to +70°C	P-20A
AD7512DIKQ	-25°C to +85°C	Q-14
AD7512DITQ	-55°C to +125°C	Q-14
AD7512DITE	-55°C to +125°C	E-20A

NOTES

¹To order MIL-STD-883, Class B, processed parts, add/883B to part number. See Analog Devices Military Products Databook (1990) for military data sheet.

²E = Leadless Ceramic Chip Carrier (LCCC); N = Plastic DIP; P = Plastic Leaded Chip Carrier (PLCC); Q = Cerdip.

REV. A

Information furnished by Analog Devices is believed to be accurate and reliable. However, no responsibility is assumed by Analog Devices for its use, nor for any infringements of patents or other rights of third parties which may result from its use. No license is granted by implication or otherwise under any patent or patent rights of Analog Devices.

AD7510DI/AD7511DI/AD7512DI — SPECIFICATIONS

($V_{DD} = +15V$, $V_{SS} = -15V$, unless otherwise noted.)

INDUSTRIAL VERSION (K)

PARAMETER	MODEL	VERSION	+25°C (N, P, Q)	0 to +70°C (N, P) -25°C to +85°C (Q)	TEST CONDITIONS
ANALOG SWITCH					
R_{ON}^1	All	K	75Ω typ, 100Ω max	175Ω max	$-10V \leq V_D \leq +10V$
R_{ON} vs V_D (V_S)	All	K	20% typ		$I_{DS} = 1.0mA$
R_{ON} Drift	All	K	+0.5%/°C typ		$V_D = 0$, $I_{DS} = 1.0mA$
R_{ON} Match	All	K	1% typ		
R_{ON} Drift Match	All	K	0.01%/°C typ		
I_D (I_S)OFF ¹	All	K	0.5nA typ, 5nA max	500nA max	$V_D = -10V$, $V_S = +10V$ and $V_D = +10V$, $V_S = -10V$
I_D (I_S)ON ¹	All	K	10nA max		$V_S = V_D = +10V$ $V_S = V_D = -10V$
I_{OUT}^1	AD7512DI	K	15nA max	1500nA max	$V_{S1} = V_{OUT} = \pm 10V$, $V_{S2} = \mp 10V$ and $V_{S2} = V_{OUT} = \pm 10V$, $V_{S1} = \mp 10V$
DIGITAL CONTROL					
V_{INL}^1	All	K		0.8V max	
V_{INH}^1	All	K		2.4V min	
C_{IN}	All	K	7pF typ		
I_{INH}^1	All	K	10nA max		$V_{IN} = V_{DD}$
I_{INL}^1	All	K	10nA max		$V_{IN} = 0$
DYNAMIC CHARACTERISTICS					
t_{ON}	AD7510DI	K	180ns typ		$V_{IN} = 0$ to +3.0V
	AD7511DI	K	350ns typ		
t_{OFF}	AD7510DI	K	350ns typ		
	AD7511DI	K	180ns typ		
$t_{TRANSITION}$	AD7512DI	K	300ns typ		
C_S (C_D)OFF	All	K	8pF typ		V_D (V_S) = 0V
C_S (C_D)ON	All	K	17pF typ		
C_{DS} (C_{S-OUT})	All	K	1pF typ		
C_{DD} (C_{SS})	All	K	0.5pF typ		
C_{OUT}	AD7512DI	K	17pF typ		
Q_{INJ}	All	K	30pC typ		Measured at S or D terminal. $C_L = 1000pF$, $V_{IN} = 0$ to 3V, V_D (V_S) = +10V to -10V
POWER SUPPLY					
I_{DD}^1	All	K	800μA max	800μA max	All digital inputs = V_{INH}
I_{SS}^1	All	K	800μA max	800μA max	
I_{DD}^1	All	K	500μA max	500μA max	All digital inputs = V_{INL}
I_{SS}^1	All	K	500μA max	500μA max	

NOTES

¹ 100% tested.

Specifications subject to change without notice.

PIN CONFIGURATIONS

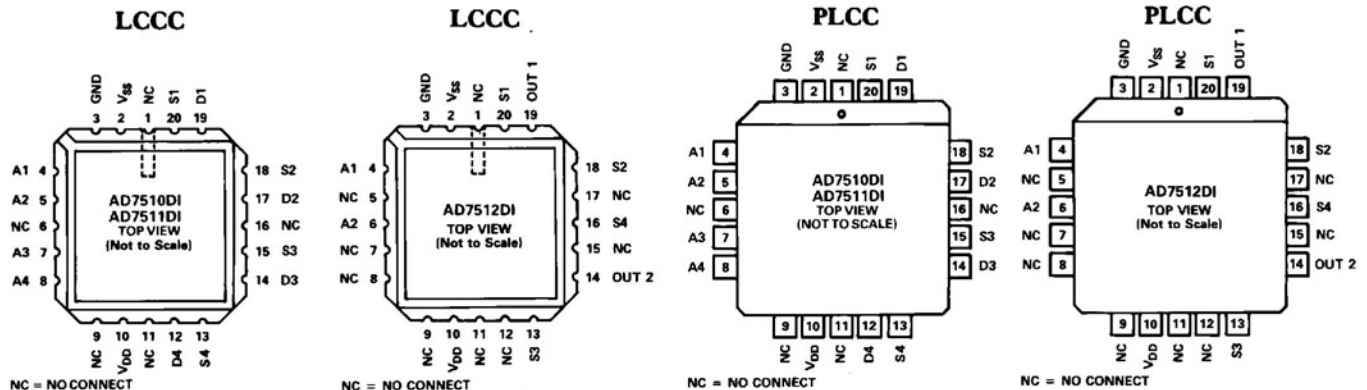

EXTENDED VERSIONS (S, T)

PARAMETER	MODEL	VERSION	+25°C	-55°C to +125°C	TEST CONDITIONS
ANALOG SWITCH					
R_{ON}^1	All	S, T	100Ω max	175Ω max	$-10V \leq V_D \leq +10V$ $I_{DS} = 1mA$
$I_D (I_S)_{OFF}^1$	All	S, T	3nA max	200nA max	$V_D = -10V, V_S = +10V$ and $V_D = +10V, V_S = -10V$
$I_D (I_S)_{ON}^1$	All	S, T	10		$V_S = V_D = +10V$ and $V_S = V_D = -10V$
I_{OUT}^1	AD7512DI	S, T	9nA max	600nA max	$V_{S1} = V_{OUT} = \pm 10V$ $V_{S2} = \mp 10V$ and $V_{S2} = V_{OUT} = \pm 10V$ $V_{S1} = \mp 10V$
DIGITAL CONTROL					
V_{INL}^1	All	S, T		0.8V max	
$V_{INH}^{1,2}$	AD7510DI	S		2.4V min	
	AD7511DI	T		2.4V min	
	AD7512DI	T		2.4V min	
	AD7511DI	S		3.0V min	
	AD7512DI	S		3.0V min	
I_{INH}^1	All	S, T	10nA max		$V_{IN} = V_{DD}$
I_{INL}^1	All	S, T	10nA max		$V_{IN} = 0$
DYNAMIC CHARACTERISTICS					
t_{ON}^3	AD7510DI	S,	1.0μs max		$V_{IN} = 0$ to +3V
	AD7511DI	S, T	1.0μs max		
t_{OFF}^3	AD7510DI	S, T	1.0μs max		
	AD7511DI	S, T	1.0μs max		
$t_{TRANSITION}^3$	AD7512DI	S, T	1.0μs max		
POWER SUPPLY					
I_{DD}^1	All	S, T		800μA max	All digital inputs = V_{INH}
I_{SS}^1	All	S, T		800μA max	
I_{DD}^1	All	S, T		500μA max	All digital inputs = V_{INL}
I_{SS}^1	All	S, T		500μA max	

NOTES

¹ 100% tested.

² A pullup resistor, typically 1-2kΩ is required to make AD7511DISQ and AD7512DISQ TTL compatible.

³ Guaranteed, not production tested.

Specifications subject to change without notice.

ABSOLUTE MAXIMUM RATINGS*

V_{DD} to GND +17V

V_{SS} to GND -17V

Overvoltage at $V_D (V_S)$

(1 second surge) $V_{DD} + 25V$
or $V_{SS} - 25V$

(Continuous) $V_{DD} + 20V$
or $V_{SS} - 20V$

or 20mA, Whichever Occurs First

Switch Current (I_{DS} , Continuous) 50mA

Switch Current (I_{DS} , Surge)

1ms Duration, 10% Duty Cycle 150mA

Digital Input Voltage Range 0V to $V_{DD} + 0.3V$

Power Dissipation (Any Package)

Up to +75°C 450mW

Derates above +75°C by 6mW/°C

Lead Temperature (Soldering, 10sec) +300°C

Storage Temperature -65°C to +150°C

Operating Temperature

Commercial (KN, KP Versions) 0 to +70°C

Industrial (KQ Versions) -25°C to +85°C

Extended (SQ, TQ, SE, TE Versions) -55°C to +125°C

*Stresses above those listed under "Absolute Maximum Ratings" may cause permanent damage to the device. This is a stress rating only and functional operation of the device at these or any other conditions above those indicated in the operational sections of this specification is not implied. Exposure to absolute maximum rating conditions for extended periods may affect device reliability.

CAUTION

ESD (electrostatic discharge) sensitive device. The digital control inputs are diode protected; however, permanent damage may occur on unconnected devices subject to high energy electrostatic fields. Unused devices must be stored in conductive foam or shunts. The protective foam should be discharged to the destination socket before devices are removed.



AD7510DI/AD7511DI/AD7512DI—Circuit Description

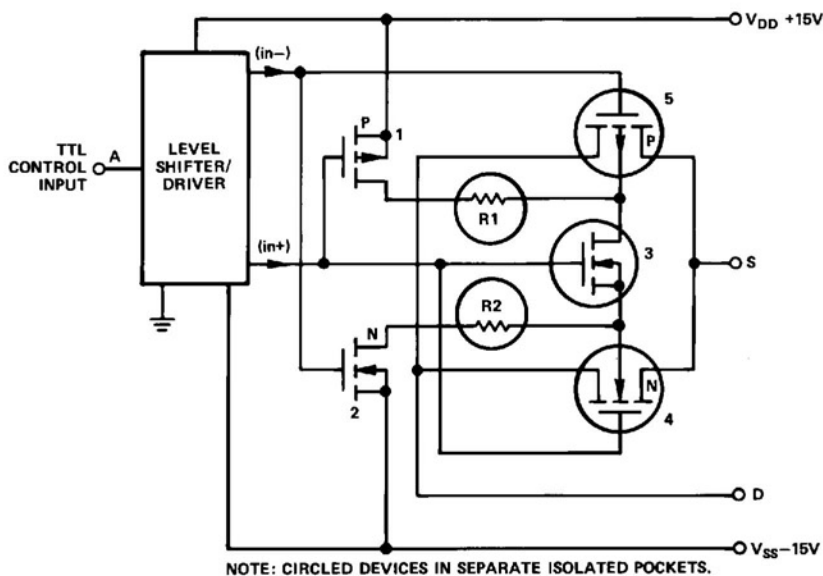

Figure 1. Typical Output Switch Circuitry of AD7510DI Series

CIRCUIT DESCRIPTION

CMOS devices make excellent analog switches; however, problems with overvoltage and latch-up phenomenon necessitated protection circuitry. These protection circuits, however, either caused degradation of important switch parameters such as R_{ON} or leakage, or provided only limited protection in the event of overvoltage.

The AD7510DI series switches utilize a dielectrically isolated CMOS fabrication process to eliminate the four-layer substrate found in junction-isolated CMOS, thus providing latch-free operation.

A typical switch channel is shown in Figure 2. The output switching element is comprised of device numbers 4 and 5. Operation is as follows: for an "ON" switch, (in+) is V_{DD} and (in-) is V_{SS} from the driver circuits. Device numbers 1 and 2 are "OFF" and number 3 is "ON". Hence, the backgates of the P- and N-channel output devices (numbers 4 and 5) are tied together and floating. The circled devices are located in separate dielectrically isolated pockets. Floating the output switch backgates with the signal input increases the effective threshold voltage for an applied analog signal, thus providing a flatter R_{ON} versus V_S response.

For an "OFF" switch, device number 3 is "OFF," and the backgates of devices 4 and 5 are tied through $1k\Omega$ resistors (R1 and R2) to the respective supply voltages through the "ON" devices 1 and 2.

If a voltage is applied to the S or D (OUT) terminal which exceeds V_{DD} or V_{SS} , the S- or D-to-backgate diode is forward biased; however, R1 and R2 provide current limiting action to the supplies.

An equivalent circuit of the output switch element in Figure 3 shows that, indeed, the $1k\Omega$ limiting resistors are in series with the backgates of the P- and N-channel output devices – not in series with the signal path between the S and D terminals.

It is possible to turn on an "OFF" switch by applying a voltage in excess of V_{DD} or V_{SS} to the S or D terminal. If a positive stress voltage is applied to the S or D terminal which exceeds V_{DD} by a threshold, then the P-channel (device 5) will turn on creating a low impedance path between the S and D terminals. A similar situation exists for negative stress voltages which exceed V_{SS} . In this case the N-channel provides the low impedance path between the S and D terminals. The limiting factor on the overvoltage protection is the power dissipation of the package and is $\pm 20V$ continuous (or 20mA whichever occurs first) above the supply voltages.

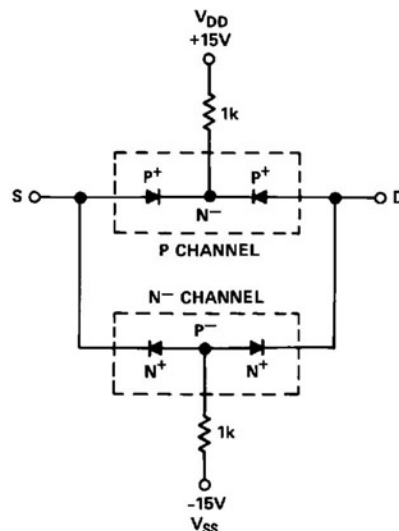
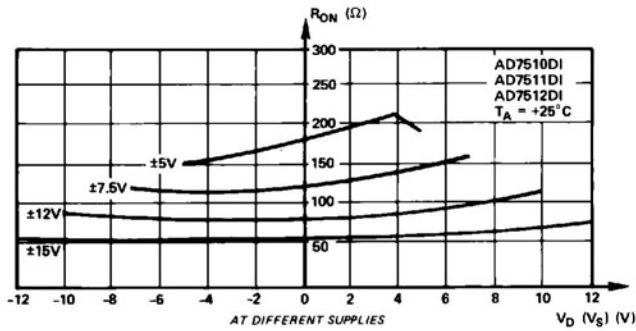
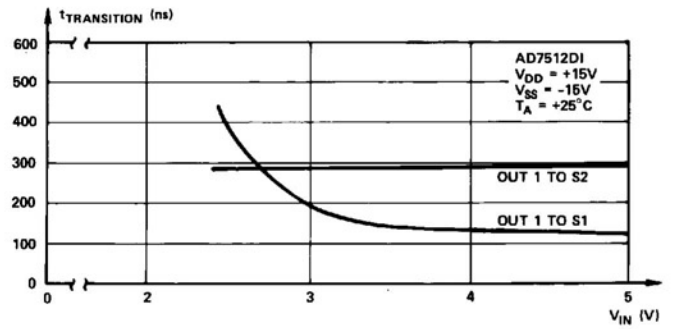

Figure 2. AD7510DI Series Output Switch Diode Equivalent Circuit

Typical Performance Characteristics—AD7510DI/AD7511DI/AD7512DI



R_{ON} as a Function of V_D (V_S)



$t_{\text{TRANSITION}}$ as a Function of Digital Input Voltage

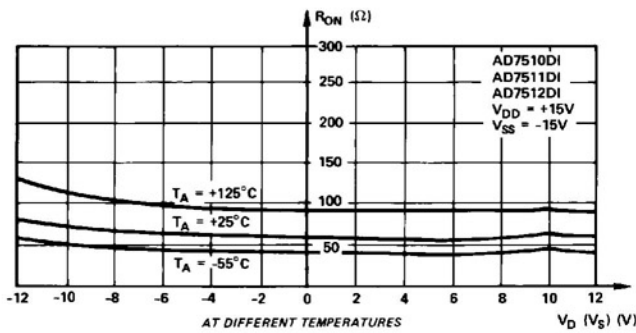

R_{ON} as a Function of V_D (V_S)

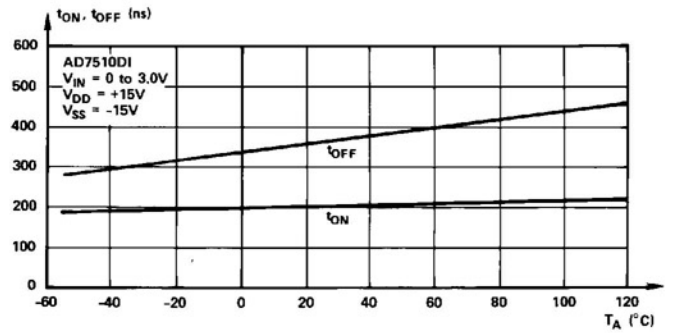

$t_{\text{ON}}, t_{\text{OFF}}$ as a Function of Temperature

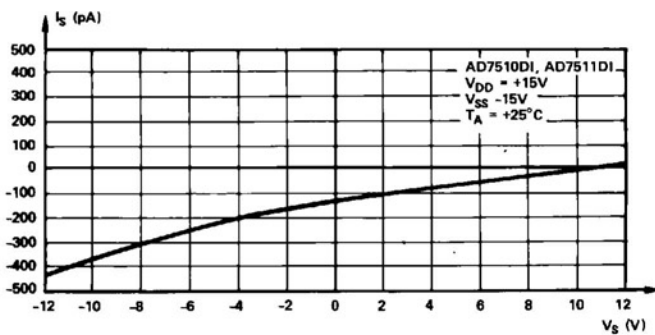

I_S , (I_D)_{OFF} vs V_S

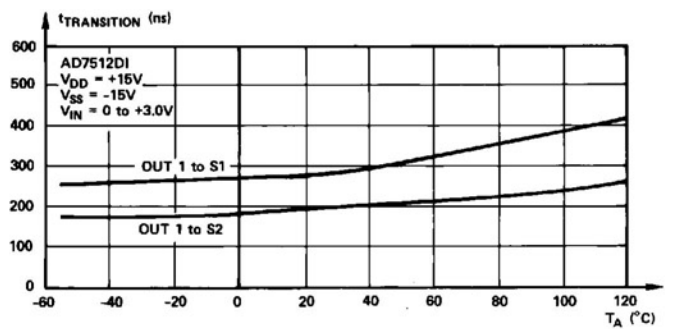

$t_{\text{TRANSITION}}$ as a Function of Temperature

AD7510DI/AD7511DI/AD7512DI

TYPICAL SWITCHING CHARACTERISTICS

AD7510DI, AD7511DI

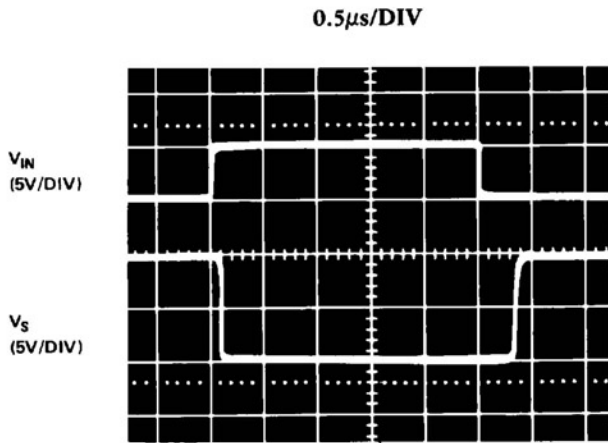

Switching Waveforms for $V_D = -10V$

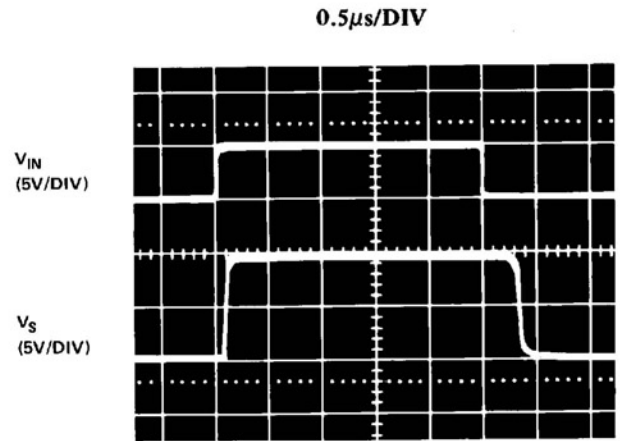

Switching Waveforms for $V_D = +10V$

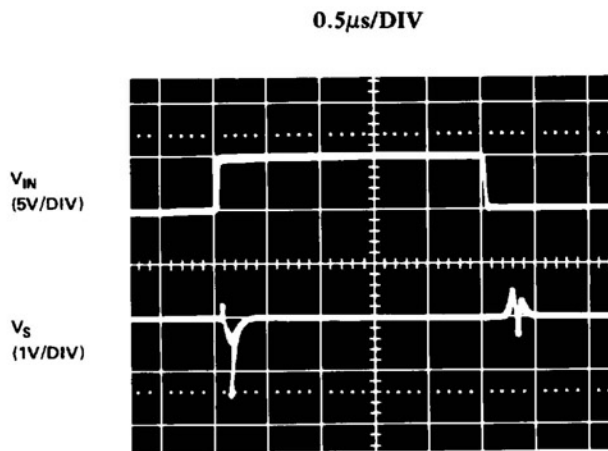

Switching Waveforms for $V_D = \text{Open}$

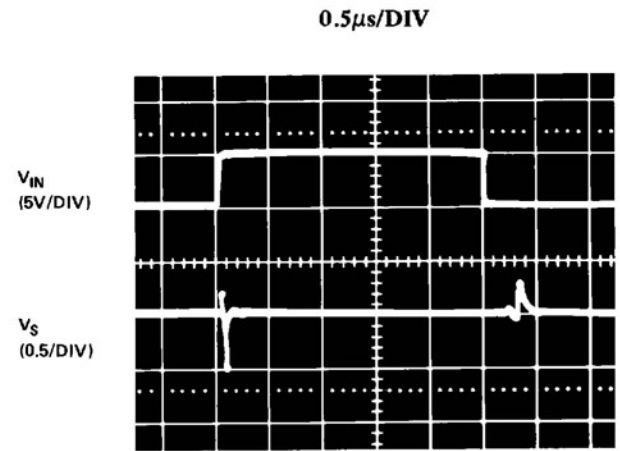

Switching Waveforms for $V_D = 0V$

AD7510DI, AD7511DI TEST CIRCUIT

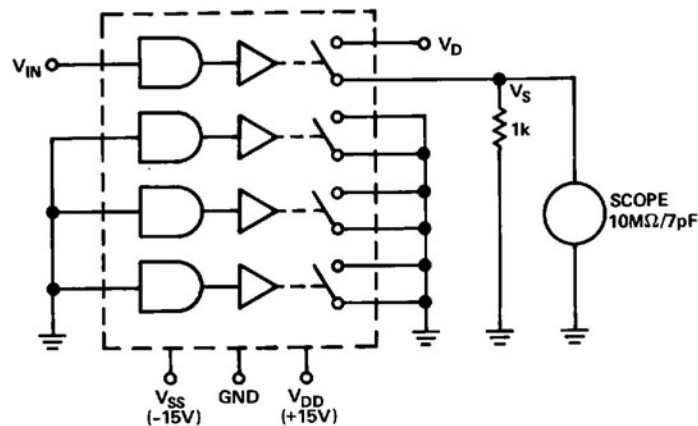

AD7512DI

0.5μs/DIV

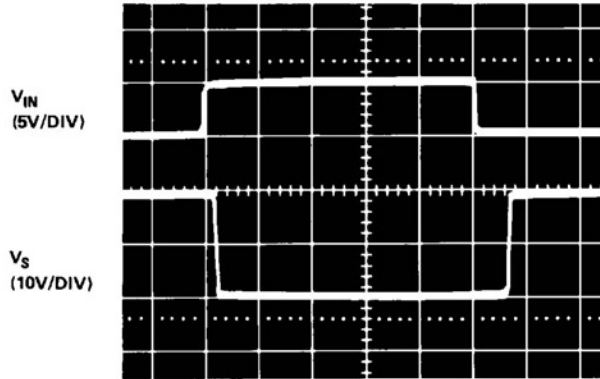

Switching Waveforms for $V_{S1} = -10V$, $V_{S2} = +10V$, $R_L = 1k$

0.5μs/DIV

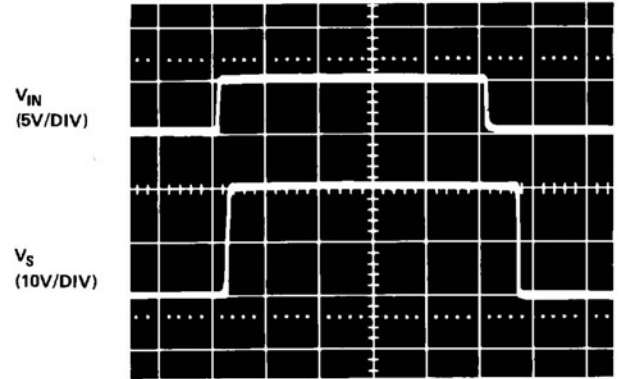

Switching Waveforms for $V_{S1} = +10V$, $V_{S2} = -10V$, $R_L = \infty$

0.5μs/DIV

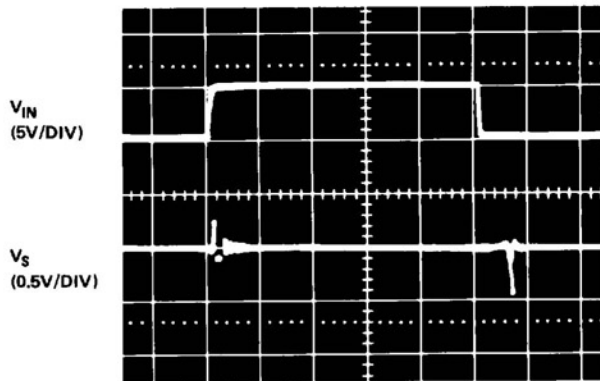

Switching Waveforms for V_{S1} and $V_{S2} = 0V$, $R_L = \infty$

0.5μs/DIV

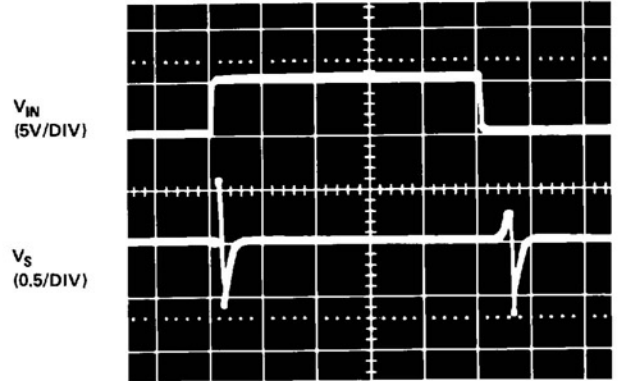

Switching Waveforms for V_{S1} and $V_{S2} = \text{Open}$, $R_L = 1k$

AD7512DI TEST CIRCUIT

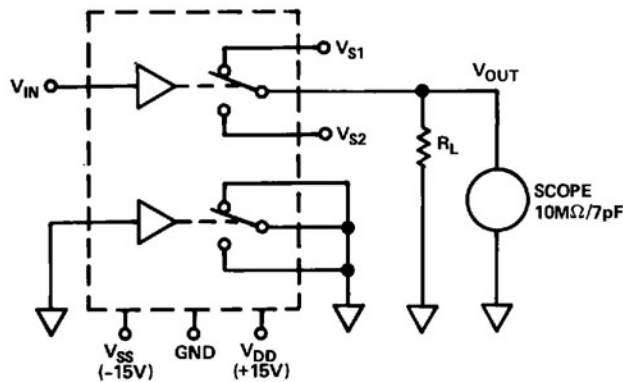

AD7510DI/AD7511DI/AD7512DI

TERMINOLOGY

R_{ON}	Ohmic resistance between terminals D and S.	$C_{DD} (C_{SS})$	Capacitance between terminals D (S) of any two switches. (This will determine the cross coupling between switches vs. frequency.)
R_{ON} Drift Match	Difference between the R_{ON} drift of any two switches.	t_{ON}	Delay time between the 50% points of the digital input and switch "ON" condition.
R_{ON} Match	Difference between the R_{ON} of any two switches.	t_{OFF}	Delay time between the 50% points of the digital input and switch "OFF" condition.
$I_D (I_S)_{OFF}$	Current at terminals D or S. This is a leakage current when the switch is "OFF".	$t_{TRANSITION}$	Delay time when switching from one address state to another.
$I_D (I_S)_{ON}$	Leakage current that flows from the closed switch into the body. (This leakage will show up as the difference between the current I_D going into the switch and the outgoing current I_S .)	V_{INL}	Maximum input voltage for a logic low.
$V_D (V_S)$	Analog voltage on terminal D (S).	V_{INH}	Minimum input voltage for a logic high.
$C_S (C_D)$	Capacitance between terminal S (D) and ground. (This capacitance is specified for the switch open and closed.)	$I_{INL} (I_{INH})$	Input current of the digital input.
C_{DS}	Capacitance between terminals D and S. (This will determine the switch isolation over frequency.)	C_{IN}	Input capacitance to ground of the digital input.
		V_{DD}	Most positive voltage supply.
		V_{SS}	Most negative voltage supply.
		I_{DD}	Positive supply current.
		I_{SS}	Negative supply current.

OUTLINE DIMENSIONS

Dimensions shown in inches and (mm).

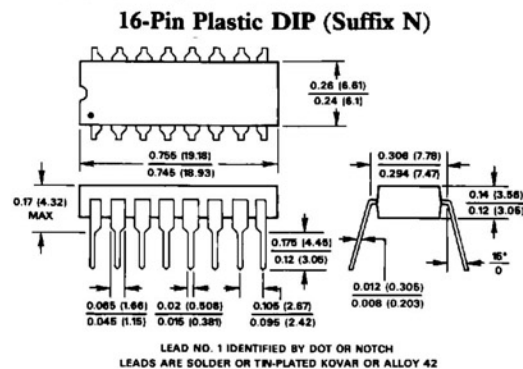
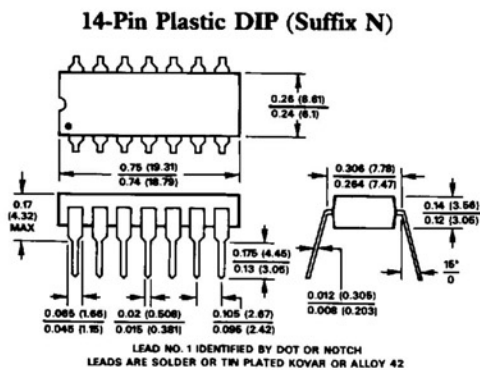
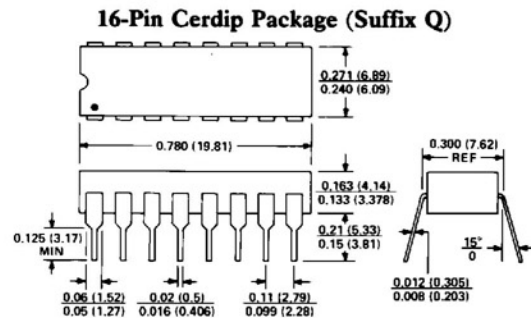
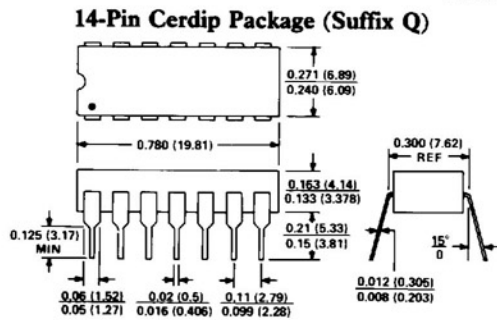

20-Terminal Leadless Ceramic Chip Carrier (Suffix E)

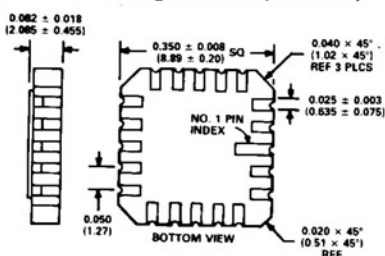

20-Terminal Plastic Leaded Chip Carrier (Suffix P)

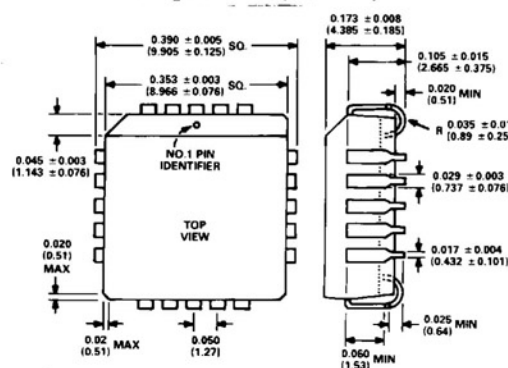

Looking for pricing, stock, or lifecycle information?

Click below to explore more details on WIN SOURCE:

 [View AD7511DIJNZ on WIN SOURCE](#)

 [Analog Devices Inc. Information](#)

Optimize Your Supply Chain with WIN SOURCE Solutions

-  Global Sourcing Solution
-  Obsolete Management
-  Cost Control Management
-  Shortage Management
-  Alternative Solution
-  Excess Inventory Management