



**THE DATASHEET OF  
AD779KNZ**



### FEATURES

AC and DC Characterized and Specified (K, B, T Grades)  
 128k Conversions per Second  
 1 MHz Full Power Bandwidth  
 500 kHz Full Linear Bandwidth  
 80 dB S/N+D (K, B, T Grades)  
 Twos Complement Data Format (Bipolar Mode)  
 Straight Binary Data Format (Unipolar Mode)  
 10 M $\Omega$  Input Impedance  
 16-Bit Bus Interface (See AD679 for 8-Bit Interface)  
 Onboard Reference and Clock  
 10 V Unipolar or Bipolar Input Range  
 MIL-STD-883 Compliant Versions Available

### FUNCTIONAL BLOCK DIAGRAM

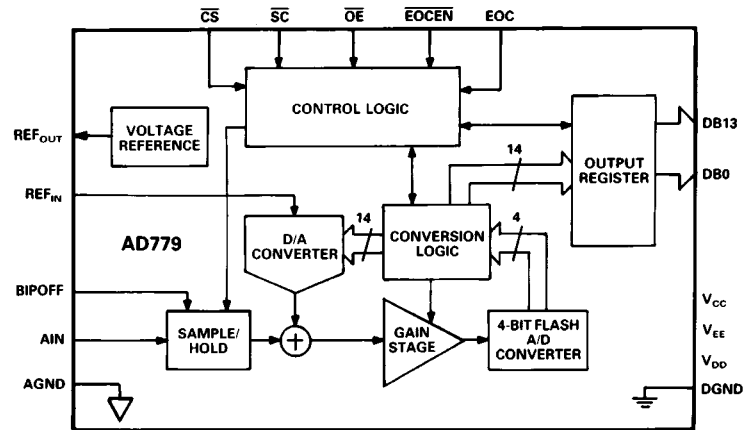

### PRODUCT DESCRIPTION

The AD779 is a complete, multipurpose 14-bit monolithic analog-to-digital converter, consisting of a sample-hold amplifier (SHA), a microprocessor compatible bus interface, a voltage reference and clock generation circuitry.

The AD779 is specified for ac (or "dynamic") parameters such as S/N+D ratio, THD and IMD which are important in signal processing applications. In addition, the AD779K, B and T grades are fully specified for dc parameters which are important in measurement applications.

The 14 data bits are accessed by a 16-bit bus in a single read operation. Data format is straight binary for unipolar mode and twos complement binary for bipolar mode. The input has a full-scale range of 10 V with a full power bandwidth of 1 MHz and a full linear bandwidth of 500 kHz. High input impedance (10 M $\Omega$ ) allows direct connection to unbuffered sources without signal degradation.

This product is fabricated on Analog Devices' BiMOS process, combining low power CMOS logic with high precision, low noise bipolar circuits; laser-trimmed thin-film resistors provide high accuracy. The converter utilizes a recursive subranging algorithm which includes error correction and flash converter circuitry to achieve high speed and resolution.

The AD779 operates from +5 V and  $\pm 12$  V supplies and dissipates 560 mW (typ). Twenty-eight-pin plastic DIP and ceramic DIP packages are available.

\*Protected by U.S. Patent Numbers 4,804,960; 4,814,767; 4,833,345; 4,250,445; 4,808,908; RE30,586.

### PRODUCT HIGHLIGHTS

- COMPLETE INTEGRATION:** The AD779 minimizes external component requirements by combining a high speed sample-hold amplifier (SHA), ADC, 5 V reference, clock and digital interface on a single chip. This provides a fully specified sampling A/D function unattainable with discrete designs.
- SPECIFICATIONS:** The AD779K, B and T grades provide fully specified and tested ac and dc parameters. The AD779J, A and S grades are specified and tested for ac parameters; dc accuracy specifications are shown as typicals. DC specifications (such as INL, gain and offset) are important in control and measurement applications. AC specifications (such as S/N+D ratio, THD and IMD) are of value in signal processing applications.
- EASE OF USE:** The pinout is designed for easy board layout, and the single cycle read output provides compatibility with 16-bit buses. Factory trimming eliminates the need for calibration modes or external trimming to achieve rated performance.
- RELIABILITY:** The AD779 utilizes Analog Devices' monolithic BiMOS technology. This ensures long term reliability compared to multichip and hybrid designs.
- The AD779 is available in versions compliant with MIL-STD-883. Refer to the Analog Devices Military Products Databook or current AD779/883B data sheet for detailed specifications.

### REV. B

Information furnished by Analog Devices is believed to be accurate and reliable. However, no responsibility is assumed by Analog Devices for its use, nor for any infringements of patents or other rights of third parties which may result from its use. No license is granted by implication or otherwise under any patent or patent rights of Analog Devices.

# AD779–SPECIFICATIONS

**AC SPECIFICATIONS** ( $T_{\text{MIN}}$  to  $T_{\text{MAX}}$ ,  $V_{\text{CC}} = +12 \text{ V} \pm 5\%$ ,  $V_{\text{EE}} = -12 \text{ V} \pm 5\%$ ,  $V_{\text{DD}} = +5 \text{ V} \pm 10\%$ ,  $f_{\text{SAMPLE}} = 128 \text{ kSPS}$ ,  $f_{\text{IN}} = 10.009 \text{ kHz}$  unless otherwise noted)<sup>1</sup>

Parameter	AD779J/A/S			AD779K/B/T			Units
	Min	Typ	Max	Min	Typ	Max	
<b>SIGNAL-TO-NOISE AND DISTORTION (S/N+D) RATIO</b>							
-0.5 dB Input (Referred to 0 dB Input)	78	79		80	81		dB
-20 dB Input (Referred to -20 dB Input)	58	59		60	61		dB
-60 dB Input (Referred to -60 dB Input)	18	19		20	21		dB
<b>TOTAL HARMONIC DISTORTION (THD)</b>							
@ +25°C		-90	-84		-90	-84	dB
$T_{\text{MIN}}$ to $T_{\text{MAX}}$		0.003	0.006		0.003	0.006	%
		-88	-82		-88	-82	dB
		0.004	0.008		0.004	0.008	%
<b>PEAK SPURIOUS OR PEAK HARMONIC COMPONENT</b>							
		-90	-84		-90	-84	dB
<b>FULL POWER BANDWIDTH</b>							
		1			1		MHz
<b>FULL LINEAR BANDWIDTH</b>							
		500			500		kHz
<b>INTERMODULATION DISTORTION (IMD)<sup>2</sup></b>							
2nd Order Products		-90	-84		-90	-84	dB
3rd Order Products		-90	-84		-90	-84	dB

**DIGITAL SPECIFICATIONS** (All device types  $T_{\text{MIN}}$  to  $T_{\text{MAX}}$ ,  $V_{\text{CC}} = +12 \text{ V} \pm 5\%$ ,  $V_{\text{EE}} = -12 \text{ V} \pm 5\%$ ,  $V_{\text{DD}} = +5 \text{ V} \pm 10\%$ )

Parameter	Test Conditions	Min	Max	Units
<b>LOGIC INPUTS</b>				
$V_{\text{IH}}$	High Level Input Voltage	2.0	$V_{\text{DD}}$	V
$V_{\text{IL}}$	Low Level Input Voltage	0	0.8	V
$I_{\text{IH}}$	High Level Input Current	$V_{\text{IN}} = V_{\text{DD}}$	+10	$\mu\text{A}$
$I_{\text{IL}}$	Low Level Input Current	$V_{\text{IN}} = 0 \text{ V}$	+10	$\mu\text{A}$
$C_{\text{IN}}$	Input Capacitance		10	pF
<b>LOGIC OUTPUTS</b>				
$V_{\text{OH}}$	High Level Output Voltage	$I_{\text{OH}} = 0.1 \text{ mA}$	4.0	V
		$I_{\text{OH}} = 0.5 \text{ mA}$	2.4	V
$V_{\text{OL}}$	Low Level Output Voltage	$I_{\text{OL}} = 1.6 \text{ mA}$	0.4	V
$I_{\text{OZ}}$	High Z Leakage Current	$V_{\text{IN}} = V_{\text{DD}}$	+10	$\mu\text{A}$
$C_{\text{OZ}}$	High Z Output Capacitance		10	pF

## NOTES

<sup>1</sup> $f_{\text{IN}}$  amplitude = -0.5 dB (9.44 V p-p) bipolar mode full scale unless otherwise indicated. All measurements referred to a -0 dB (9.997 V p-p) input signal unless otherwise noted.

<sup>2</sup> $f_{\text{A}} = 9.08 \text{ kHz}$ ,  $f_{\text{B}} = 9.58 \text{ kHz}$ , with  $f_{\text{SAMPLE}} = 128 \text{ kSPS}$ .

Specifications subject to change without notice.

**DC SPECIFICATIONS** ( $T_{MIN}$  to  $T_{MAX}$ ,  $V_{CC} = +12\text{ V} \pm 5\%$ ,  $V_{EE} = -12\text{ V} \pm 5\%$ ,  $V_{DD} = +5\text{ V} \pm 10\%$  unless otherwise noted)

Parameter	AD779J/A/S			AD779K/B/T			Units
	Min	Typ	Max	Min	Typ	Max	
TEMPERATURE RANGE							
J, K Grades	0		+70	0		+70	°C
A, B Grades	-40		+85	-40		+85	°C
S, T Grades	-55		+125	-55		+125	°C
ACCURACY							
Resolution	14			14			Bits
Integral Nonlinearity (INL)		±2			±1	±2	LSB
Differential Nonlinearity (DNL)	14			14			Bits
Unipolar Zero Error <sup>1</sup> (@ +25°C)		0.08			0.05	0.07	% FSR*
Bipolar Zero Error <sup>1</sup> (@ +25°C)		0.08			0.05	0.07	% FSR
Gain Error <sup>1,2</sup> (@ +25°C)		0.12			0.09	0.11	% FSR
Temperature Drift							
Unipolar Zero <sup>3</sup>							
J, K Grades		0.04			0.04	0.05	% FSR
A, B Grades		0.05			0.05	0.07	% FSR
S, T Grades		0.09			0.09	0.10	% FSR
Bipolar Zero <sup>3</sup>							
J, K Grades		0.02			0.02	0.04	% FSR
A, B Grades		0.04			0.04	0.06	% FSR
S, T Grades		0.08			0.08	0.09	% FSR
Gain <sup>3</sup>							
J, K Grades		0.09			0.09	0.11	% FSR
A, B Grades		0.10			0.10	0.16	% FSR
S, T Grades		0.20			0.20	0.25	% FSR
Gain <sup>4</sup>							
J, K Grades		0.04			0.04	0.05	% FSR
A, B Grades		0.05			0.05	0.07	% FSR
S, T Grades		0.09			0.09	0.10	% FSR
ANALOG INPUT							
Input Ranges							
Unipolar Mode	0		+10	0		+10	V
Bipolar Mode	-5		+5	-5		+5	V
Input Resistance		10			10		MΩ
Input Capacitance		10			10		pF
Input Settling Time			1.5			1.5	μs
Aperture Delay		10			10		ns
Aperture Jitter		150			150		ps
INTERNAL VOLTAGE REFERENCE							
Output Voltage <sup>5</sup>	4.98		5.02	4.98		5.02	V
External Load							
Unipolar Mode			+1.5			+1.5	mA
Bipolar Mode			+0.5			+0.5	mA
POWER SUPPLIES							
Power Supply Rejection							
$V_{CC} = +12\text{ V} \pm 5\%$		±6			±6		LSB
$V_{EE} = -12\text{ V} \pm 5\%$		±6			±6		LSB
$V_{DD} = +5\text{ V} \pm 10\%$		±6			±6		LSB
Operating Current							
$I_{CC}$		18	20		18	20	mA
$I_{EE}$		25	34		25	34	mA
$I_{DD}$		8	12		8	12	mA
Power Consumption		560	745		560	745	mW

## NOTES

<sup>1</sup>Adjustable to zero. See Figures 5 and 6.<sup>2</sup>Includes internal voltage reference error.<sup>3</sup>Includes internal voltage reference drift.<sup>4</sup>Excludes internal voltage reference drift.<sup>5</sup>With maximum external load applied.

\*% FSR = percent of full-scale range.

Specifications subject to change without notice.

## TIMING SPECIFICATIONS

(All device types  $T_{MIN}$  to  $T_{MAX}$ ,  $V_{CC} = +12\text{ V} \pm 5\%$ ,  $V_{EE} = -12\text{ V} \pm 5\%$ ,  $V_{DD} = +5\text{ V} \pm 10\%$ )

Parameter	Symbol	Min	Max	Units
Conversion Rate <sup>1</sup>	$t_{CR}$		7.8	$\mu\text{s}$
Convert Pulse Width	$t_{CP}$	0.097	3.0	$\mu\text{s}$
Aperture Delay	$t_{AD}$	5	20	ns
Conversion Time	$t_C$		6.3	$\mu\text{s}$
Status Delay	$t_{SD}$	0	400	ns
Access Time <sup>2, 3</sup>	$t_{BA}$	10	100	ns
		10	57 <sup>4</sup>	ns
Float Delay <sup>5</sup>	$t_{FD}$	10	80	ns
Output Delay	$t_{OD}$		0	ns
OE Delay	$t_{OE}$	20		ns
Read Pulse Width	$t_{RP}$	100		ns
Conversion Delay	$t_{CD}$	400		ns

**NOTES**

<sup>1</sup>Includes Acquisition Time.

<sup>2</sup>Measured from the falling edge of  $\overline{\text{OE/EOCEN}}$  (0.8 V) to the time at which the data lines/EOC cross 2.0 V or 0.8 V. See Figure 4.

<sup>3</sup> $C_{OUT} = 100\text{ pF}$ .

<sup>4</sup> $C_{OUT} = 50\text{ pF}$ .

<sup>5</sup>Measured from the rising edge of  $\overline{\text{OE/EOCEN}}$  (2.0 V) to the time at which the output voltage changes by 0.5 V. See Figure 4;  $C_{OUT} = 10\text{ pF}$ .

Specifications subject to change without notice.

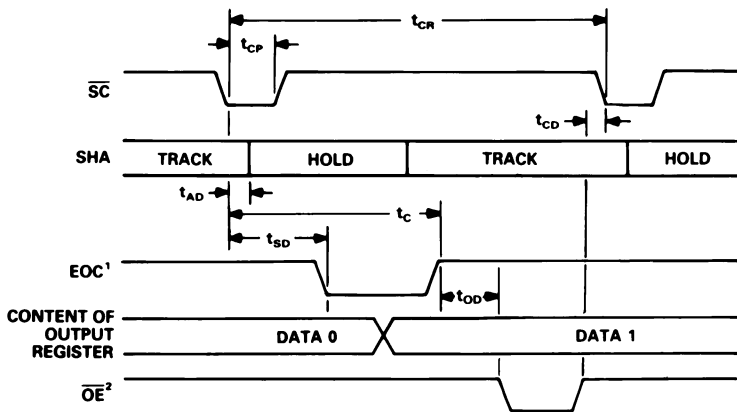

**NOTES**

<sup>1</sup> $\overline{\text{EOCEN}} = \text{LOW}$ .

<sup>2</sup>DATA SHOULD NOT BE ENABLED DURING A CONVERSION.

Figure 1. Conversion Timing

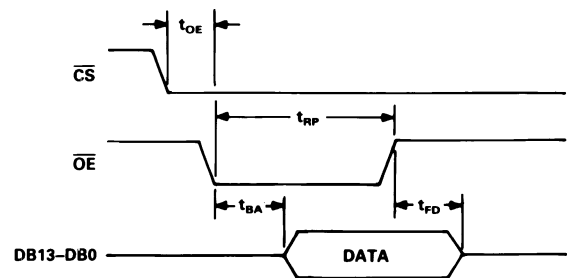

Figure 3. EOC Timing

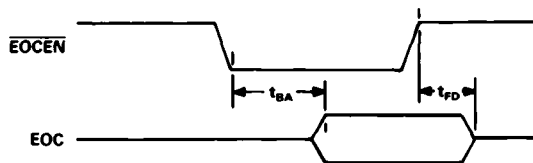

Figure 2. Output Timing

TEST	$V_{CP}$	$C_{OUT}$
ACCESS TIME HIGH Z TO LOGIC LOW	5 V	100 pF
FLOAT TIME LOGIC HIGH TO HIGH Z	0 V	10 pF
ACCESS TIME HIGH Z TO LOGIC HIGH	0 V	100 pF
FLOAT TIME LOGIC LOW TO HIGH Z	5 V	10 pF

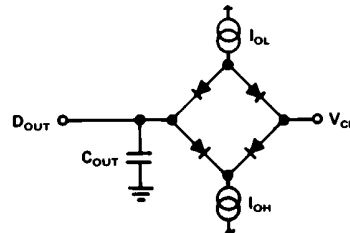

Figure 4. Load Circuit for Bus Timing Specifications

**ABSOLUTE MAXIMUM RATINGS<sup>1</sup>**

Specification	With Respect To	Min	Max	Units
V <sub>CC</sub>	AGND	-0.3	+18	V
V <sub>BE</sub>	AGND	-18	+0.3	V
V <sub>CC</sub> <sup>2</sup>	V <sub>EE</sub>	-0.3	+26.4	V
V <sub>DD</sub>	DGND	0	+7	V
AGND	DGND	-1	+1	V
A <sub>IN</sub> , REF <sub>IN</sub>	AGND	V <sub>EE</sub>	V <sub>CC</sub>	V
Digital Inputs	DGND	-0.5	+7	V
Digital Outputs	DGND	-0.5	V <sub>DD</sub> +0.3	V
Max Junction Temperature			175	°C
Operating Temperature				
J and K Grades		0	+70	°C
A and B Grades		-40	+85	°C
S and T Grades		-55	+125	°C
Storage Temperature		-65	+150	°C
Lead Temperature (10 sec max)			+300	°C

**NOTES**

<sup>1</sup>Stresses above those listed under “Absolute Maximum Ratings” may cause permanent damage to the device. This is a stress rating only and functional operation of the device at these or any other conditions above those indicated in the operational sections of this specification is not implied. Exposure to absolute maximum rating conditions for extended periods may affect device reliability.

<sup>2</sup>The AD779 is not designed to operate from ±15 V supplies.

**ESD SENSITIVITY**

The AD779 features input protection circuitry consisting of large “distributed” diodes and polysilicon series resistors to dissipate both high energy discharges (Human Body Model) and fast, low energy pulses (Charged Device Model). Per Method 3015.2 of MIL-STD-883C, the AD779 has been classified as a Category 1 device.

Proper ESD precautions are strongly recommended to avoid functional damage or performance degradation. Charges as high as 4000 volts readily accumulate on the human body and test equipment and discharge without detection. Unused devices must be stored in conductive foam or shunts, and the foam should be discharged to the destination socket before devices are removed. For further information on ESD precautions, refer to Analog Devices’ *ESD Prevention Manual*.

**ORDERING GUIDE<sup>1</sup>**

Model <sup>2</sup>	Temperature Range	Tested and Specified	Package Description	Package Option <sup>3</sup>
AD779JN	0°C to +70°C	AC	28-Pin Plastic DIP	N-28
AD779KN	0°C to +70°C	AC + DC	28-Pin Plastic DIP	N-28
AD779JD	0°C to +70°C	AC	28-Pin Ceramic DIP	D-28
AD779KD	0°C to +70°C	AC + DC	28-Pin Ceramic DIP	D-28
AD779AD	-40°C to +85°C	AC	28-Pin Ceramic DIP	D-28
AD779BD	-40°C to +85°C	AC + DC	28-Pin Ceramic DIP	D-28
AD779SD	-55°C to +125°C	AC	28-Pin Ceramic DIP	D-28
AD779TD	-55°C to +125°C	AC + DC	28-Pin Ceramic DIP	D-28

**NOTES**

<sup>1</sup>For two cycle read (8+16 bits) interface to 8-bit buses, see AD679.

<sup>2</sup>For details on grade and package offerings screened in accordance with MIL-STD-883, refer to the Analog Devices Military Products Databook or current AD779/883B data sheet.

<sup>3</sup>D = Ceramic DIP; N = Plastic DIP.

## PIN DESCRIPTION

Symbol	28-Pin DIP Pin No.	Type	Name and Function
AGND	7	P	Analog Ground. This is the ground return for AIN only.
AIN	6	AI	Analog Signal Input.
BIPOFF	10	AI	Bipolar Offset. Connect to AGND for +10 V input unipolar mode and straight binary output coding. Connect to REF <sub>OUT</sub> for ±5 V input bipolar mode and twos-complement binary output coding.
$\overline{CS}$	12	DI	Chip Select. Active LOW.
DGND	14	P	Digital Ground.
DB13-DB0	28-15	DO	Data Bits. These pins provide all 14 bits in one 14 bit parallel output. Active HIGH.
EOC	2	DO	End-of-Convert. EOC goes LOW when a conversion starts and goes HIGH when the conversion is finished. EOC is a three-state output. See $\overline{EOCEN}$ pin for information on EOC gating.
$\overline{EOCEN}$	13	DI	End-of-Convert Enable. Enables EOC pin. Active LOW.
$\overline{OE}$	3	DI	Output Enable. A down-going transition on $\overline{OE}$ enables data bits. Active LOW.
REF <sub>IN</sub>	9	AI	Reference Input. +5 V input gives 10 V full scale range.
REF <sub>OUT</sub>	8	AO	+5 V Reference Output. Tied to REF <sub>IN</sub> for normal operation.
$\overline{SC}$	4	DI	Start Convert. Active LOW.
V <sub>CC</sub>	11	P	+12 V Analog Power.
V <sub>EE</sub>	5	P	-12 V Analog Power.
V <sub>DD</sub>	1	P	+5 V Digital Power.

Type: AI = Analog Input.  
 AO = Analog Output.  
 DI = Digital Input.  
 DO = Digital Output. All DO pins are three-state drivers.  
 P = Power.

## PIN CONFIGURATION DIP Package

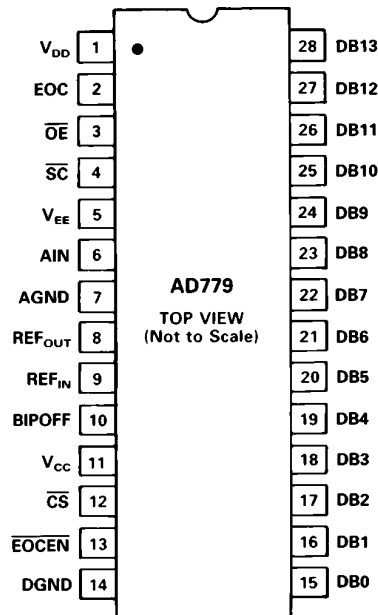

**DEFINITION OF SPECIFICATIONS****NYQUIST FREQUENCY**

An implication of the Nyquist sampling theorem, the “Nyquist Frequency” of a converter is that input frequency which is one-half the sampling frequency of the converter.

**SIGNAL-TO-NOISE AND DISTORTION (S/N+D) RATIO**

S/N+D is the ratio of the rms value of the measured input signal to the rms sum of all other spectral components below the Nyquist frequency, including harmonics but excluding dc.

**TOTAL HARMONIC DISTORTION (THD)**

THD is the ratio of the rms sum of the first six harmonic components to the rms value of a full-scale input signal and is expressed as a percentage or in decibels. For input signals or harmonics that are above the Nyquist frequency, the aliased component is used.

**PEAK SPURIOUS OR PEAK HARMONIC COMPONENT**

The peak spurious or peak harmonic component is the largest spectral component excluding the input signal and dc. This value is expressed in decibels relative to the rms value of a full-scale input signal.

**INTERMODULATION DISTORTION (IMD)**

With inputs consisting of sine waves at two frequencies,  $f_a$  and  $f_b$ , any device with nonlinearities will create distortion products, of order  $(m + n)$ , at sum and difference frequencies of  $m f_a \pm n f_b$ , where  $m, n = 0, 1, 2, 3, \dots$ . Intermodulation terms are those for which  $m$  or  $n$  is not equal to zero. For example, the second order terms are  $(f_a + f_b)$  and  $(f_a - f_b)$  and the third order terms are  $(2 f_a + f_b)$ ,  $(2 f_a - f_b)$ ,  $(f_a + 2 f_b)$  and  $(f_a - 2 f_b)$ . The IMD products are expressed as the decibel ratio of the rms sum of the measured input signals to the rms sum of the distortion terms. The two signals applied to the converter are of equal amplitude and the peak value of their sum is  $-0.5$  dB from full scale (9.44 V p-p). The IMD products are normalized to a 0-dB input signal.

**BANDWIDTH**

The full-power bandwidth is that input frequency at which the amplitude of the reconstructed fundamental is reduced by 3 dB for a full-scale input.

The full-linear bandwidth is the input frequency at which the slew rate limit of the sample-and-hold-amplifier (SHA) is reached. At this point, the amplitude of the reconstructed fundamental has degraded by less than  $-0.1$  dB. Beyond this frequency, distortion of the sampled input signal increases significantly.

The AD779 has been designed to optimize input bandwidth, allowing it to undersample input signals with frequencies significantly above the converter’s Nyquist frequency.

**APERTURE DELAY**

Aperture delay is a measure of the SHA’s performance and is measured from the falling edge of Start Convert ( $\overline{SC}$ ) to when the input signal is held for conversion.

**APERTURE JITTER**

Aperture jitter is the variation in aperture delay for successive samples and is manifested as noise on the input to the A/D.

**INPUT SETTling TIME**

Settling time is a function of the SHA’s ability to track fast slewing signals. This is specified as the maximum time required in track mode after a full-scale step input to guarantee rated conversion accuracy.

**DIFFERENTIAL NONLINEARITY (DNL)**

In an ideal ADC, code transitions are 1 LSB apart. Differential linearity is the deviation from this ideal value. It is often specified in terms of resolution for which no missing codes (NMC) are guaranteed.

**INTEGRAL NONLINEARITY (INL)**

The ideal transfer function for a linear ADC is a straight line drawn between “zero” and “full scale.” The point used as “zero” occurs  $1/2$  LSB before the first code transition. “Full scale” is defined as a level  $1 1/2$  LSB beyond the last code transition. Integral nonlinearity error is the worst case deviation of a code from the straight line. The deviation of each code is measured from the middle of that code.

Note that the linearity error is not user adjustable.

**POWER SUPPLY REJECTION**

Variations in power supply will affect the full-scale transition, but not the converter’s linearity. Power Supply Rejection is the maximum change in the full-scale transition point due to a change in power supply voltage from the nominal value.

**TEMPERATURE DRIFT**

This is the maximum change in the parameter from the initial value ( $@+25^\circ\text{C}$ ) to the value at  $T_{\text{MIN}}$  or  $T_{\text{MAX}}$ .

**UNIPOLAR ZERO ERROR**

In unipolar mode, the first transition should occur at a level  $1/2$  LSB above analog ground. Unipolar zero error is the deviation of the actual transition from that point. This error can be adjusted as discussed in the Input Connections and Calibration section.

**BIPOLAR ZERO ERROR**

In the bipolar mode, the major carry transition (11 1111 1111 1111 to 00 0000 0000 0000) should occur at an analog value  $1/2$  LSB below analog ground. Bipolar zero error is the deviation of the actual transition from that point. This error can be adjusted as discussed in the Input Connections and Calibration section.

**GAIN ERROR**

The last transition should occur at an analog value  $1 1/2$  LSB below the nominal full scale (9.9991 volts for a 0 V–10 V range, 4.9991 volts for a  $\pm 5$  V range). The gain error is the deviation of the actual level at the last transition from the ideal level with the zero error trimmed out. This error can be adjusted as shown in the Input Connections and Calibration section.

# AD779

## CONVERSION TRUTH TABLE

Mode	INPUTS				OUTPUTS		Status
	$\overline{SC}$	$\overline{EOCEN}$	$\overline{CS}$	$\overline{OE}$	EOC	DB13 . . . DB0	
Start Conversion	1	X	X	X			No Conversion
	$\bar{1}$	X	X	X			Start Conversion
	0	X	X	X			Continuous Conversion (Not Recommended)
Conversion Status	X	0	X	X	0		Converting
	X	0	X	X	1		Not Converting
	X	1	X	X	High Z		Either
Data Access	X	X	X	1		High Z	Three-State
	X	X	1	X		High Z	Three-State
	X	X	0	0		MSB . . . LSB	Data Out

### NOTES

1 = HIGH voltage level.

0 = LOW voltage level.

X = Don't care.

$\bar{1}$  = HIGH to LOW transition. Must stay LOW for  $t = t_{CP}$ .

## CONVERSION CONTROL

Before a conversion is started, End-of-Convert (EOC) is HIGH and the sample-hold is in track mode. A conversion is started by bringing SC LOW, regardless of the state of CS.

After a conversion is started, the sample-hold goes into hold mode and EOC goes LOW, signifying that a conversion is in progress. During the conversion, the sample-hold will go back into track mode and start acquiring the next sample.

In track mode, the sample-hold will settle to  $\pm 0.003\%$  (14 bits) in 1.5  $\mu$ s maximum. The acquisition time does not affect the throughput rate as the AD779 goes back into track mode more than 2  $\mu$ s before the next conversion. In multichannel systems, the input channel can be switched as soon as EOC goes LOW if the maximum throughput rate is needed.

When EOC goes HIGH, the conversion is completed and the output data may be read. Bringing OE LOW makes the output register contents available on the output data bits (DB13–DB0). A period of time  $t_{CD}$  is required after OE is brought HIGH before the next SC instruction is issued.

If SC is held LOW, conversion accuracy may deteriorate. For this reason, SC should not be held low in any attempt to operate in a continuously converting mode.

## END-OF-CONVERT

End-of-Convert (EOC) is a three-state output which is enabled by End-of-Convert Enable EOCEN.

## OUTPUT ENABLE OPERATION

The data bits (DB13–DB0) are three-state outputs that are enabled by Chip Select ( $\overline{CS}$ ) and Output Enable ( $\overline{OE}$ ).  $\overline{CS}$  should be LOW  $t_{OE}$  before  $\overline{OE}$  is brought LOW. The output is read in a single cycle as a 14-bit word.

In unipolar mode (BIPOFF tied to AGND), the output coding is straight binary. In bipolar mode (BIPOFF tied to REF<sub>OUT</sub>), output coding is twos complement binary.

## POWER-UP

The AD779 typically requires 10  $\mu$ s after power-up to reset internal logic

## 14-BIT MODE CODING FORMAT (1 LSB = 0.61 mV)

Unipolar Coding (Straight Binary)		Bipolar Coding (Twos Complement)	
V <sub>IN</sub>	Output Code	V <sub>IN</sub>	Output Code
0.00000 V	000 . . . 0	-5.00000 V	100 . . . 0
5.00000 V	100 . . . 0	-0.00061 V	111 . . . 1
9.99939 V	111 . . . 1	0.00000 V	000 . . . 0
		+2.50000 V	010 . . . 0
		+4.99939 V	011 . . . 1

## Application Information

### INPUT CONNECTIONS AND CALIBRATION

The high (10 M $\Omega$ ) input impedance of the AD779 eases the task of interfacing to high source impedances or multiplexer channel-to-channel mismatches of up to 300  $\Omega$ . The 10 V p-p full-scale input range accepts the majority of signal voltages without the need for voltage divider networks which could deteriorate the accuracy of the ADC.

The AD779 is factory trimmed to minimize offset, gain and linearity errors. In unipolar mode, the only external component that is required is a 50  $\Omega \pm 1\%$  resistor. Two resistors are required in bipolar mode. If offset and gain are not critical, even these components can be eliminated.

In some applications, offset and gain errors need to be more precisely trimmed. The following sections describe the correct procedure for these various situations.

### BIPOLAR RANGE INPUTS

The connections for the bipolar mode are shown in Figure 5. In this mode, data output coding will be twos complement binary. This circuit will allow approximately  $\pm 25$  mV of offset trim range ( $\pm 40$  LSB) and  $\pm 0.5\%$  of gain trim range ( $\pm 80$  LSB).

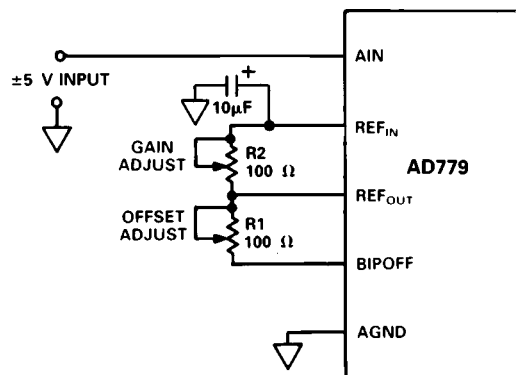

Figure 5. Bipolar Input Connections with Gain and Offset Trims

Either or both of the trim pots can be replaced with  $50 \Omega \pm 1\%$  fixed resistors if the AD779 accuracy limits are sufficient for the application. If the pins are shorted together, the additional offset and gain errors will be approximately 80 LSB.

To trim bipolar zero to its nominal value, apply a signal 1/2 LSB below midrange ( $-0.305$  mV for a  $\pm 5$  V range) and adjust R1 until the major carry transition is located (11 1111 1111 1111 to 00 0000 0000 0000). To trim the gain, apply a signal 1/2 LSB below full scale ( $+4.9991$  V for a  $\pm 5$  V range) and adjust R2 to give the last positive transition (01 1111 1111 1110 to 01 1111 1111 1111). These trims are interactive so several iterations may be necessary for convergence.

A single pass calibration can be done by substituting a bipolar offset trim (error at minus full scale) for the bipolar zero trim (error at midscale), using the same circuit. First, apply a signal 1/2 LSB above minus full scale ( $-4.9997$  V for a  $\pm 5$  V range) and adjust R1 until the minus full-scale transition is located (10 0000 0000 0000 to 10 000 000 0001). Then perform the gain error trim as outlined above.

### UNIPOLAR RANGE INPUTS

Offset and gain errors can be trimmed out by using the configuration shown in Figure 6. This circuit allows approximately  $\pm 25$  mV of offset trim range ( $\pm 40$  LSB) and  $\pm 0.5\%$  of gain trim range ( $\pm 80$  LSB).

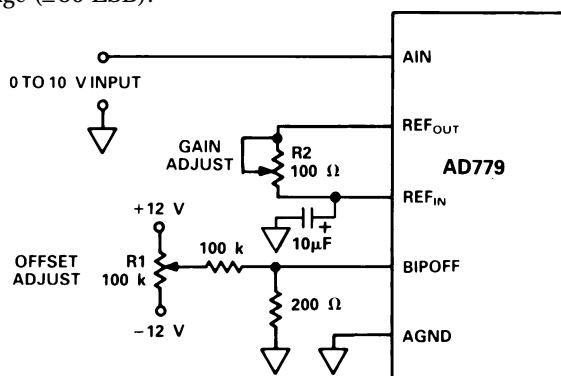

Figure 6. Unipolar Input Connections with Gain and Offset Trims

The first transition (from 00 0000 0000 0000 to 00 0000 0000 0001) should nominally occur for an input level of  $+1/2$  LSB ( $0.305$  mV above ground for a 10 V range). To trim unipolar zero to this nominal value, apply a  $0.305$  mV signal to AIN and adjust R1 until the first transition is located.

The gain trim is done by adjusting R2. If the nominal value is required, apply a signal 1/2 LSB below full scale ( $9.9997$  V for a 10 V range) and adjust R2 until the last transition is located (11 1111 1111 1110 to 11 1111 1111 1111).

If offset adjustment is not required, BIPOFF should be connected directly to AGND. If gain adjustment is not required, R2 should be replaced with a fixed  $50 \Omega \pm 1\%$  metal film resistor. If REF\_OUT is connected directly to REF\_IN, the additional gain error will be approximately 1%.

### REFERENCE DECOUPLING

It is recommended that a  $10 \mu\text{F}$  tantalum capacitor be connected between REF\_IN (Pin 9) and ground. This has the effect of improving the S/N+D ratio through filtering possible broadband noise contributions from the voltage reference.

### BOARD LAYOUT

Designing with high resolution data converters requires careful attention to board layout. Trace impedance is a significant issue. A  $1.22$  mA current through a  $0.5 \Omega$  trace will develop a voltage drop of  $0.6$  mV, which is 1 LSB at the 14-bit level for a 10 V full-scale span. In addition to ground drops, inductive and capacitive coupling need to be considered, especially when high accuracy analog signals share the same board with digital signals. Finally, power supplies need to be decoupled in order to filter out ac noise.

Analog and digital signals should not share a common path. Each signal should have an appropriate analog or digital return routed close to it. Using this approach, signal loops enclose a small area, minimizing the inductive coupling of noise. Wide PC tracks, large gauge wire, and ground planes are highly recommended to provide low impedance signal paths. Separate analog and digital ground planes are also desirable, with a single interconnection point to minimize ground loops. Analog signals should be routed as far as possible from digital signals and should cross them at right angles.

The AD779 incorporates several features to help the user's layout. Analog pins ( $V_{BE}$ , AIN, AGND, REF\_OUT, REF\_IN, BIPOFF,  $V_{CC}$ ) are adjacent to help isolate analog from digital signals. In addition, the  $10 \text{ M}\Omega$  input impedance of AIN minimizes input trace impedance errors. Finally, ground currents have been minimized by careful circuit design. Current through AGND is  $200 \mu\text{A}$ , with no code dependent variation. The current through DGND is dominated by the return current for DB13–DB0 and EOC.

### SUPPLY DECOUPLING

The AD779 power supplies should be well filtered, well regulated, and free from high frequency noise. Switching power supplies are not recommended due to their tendency to generate spikes which can induce noise in the analog system.

Decoupling capacitors should be used as close as possible to all power supply pins. A  $10 \mu\text{F}$  tantalum capacitor in parallel with a  $0.1 \mu\text{F}$  ceramic capacitor provides adequate decoupling.

# AD779

An effort should be made to minimize the trace length between the capacitor leads and the respective converter power supply and common pins. The circuit layout should attempt to locate the AD779, associated analog input circuitry and interconnections as far as possible from logic circuitry. A solid analog ground plane around the AD779 will isolate large switching ground currents. For these reasons, the use of wire wrap circuit construction is not recommended; careful printed circuit construction is preferred.

## GROUNDING

If a single AD779 is used with separate analog and digital ground planes, connect the analog ground plane to AGND and the digital ground plane to DGND keeping lead lengths as short as possible. Then connect AGND and DGND together at the AD779. If multiple AD779s are used or the AD779 shares analog supplies with other components, connect the analog and digital returns together once at the power supplies rather than at each chip. This prevents large ground loops which inductively couple noise and allow digital currents to flow through the analog system.

## USE OF EXTERNAL VOLTAGE REFERENCE

The AD779 features an on-chip voltage reference. For improved gain accuracy over temperature, a high performance external voltage reference may be used in place of the on-chip reference.

The AD586 and AD588 are popular references appropriate for use with high resolution converters. The AD586 is a low cost reference which utilizes a buried Zener architecture to provide low noise and drift. The AD588 is a higher performance reference which uses a proprietary ion-implanted buried Zener diode in conjunction with laser-trimmed thin-film resistors for low offset and low drift.

Figure 7 shows the use of the AD586 with the AD779 in a bipolar input mode. Over the 0°C to +70°C range, the AD586 L-grade exhibits less than a 2.25 mV output change from its initial value at 25°C. REF<sub>IN</sub>, (Pin 9) scales its input by a factor of two; thus, this change becomes effectively 4.5 mV. When applied to the AD779, this results in a total gain drift of 0.09% FSR which is an improvement over the on-chip reference performance of 0.11% FSR. A noise-reduction capacitor, C<sub>N</sub>, has been shown. This capacitor reduces the broadband noise of the AD586 output, thereby optimizing the overall ac and dc performance of the AD779.

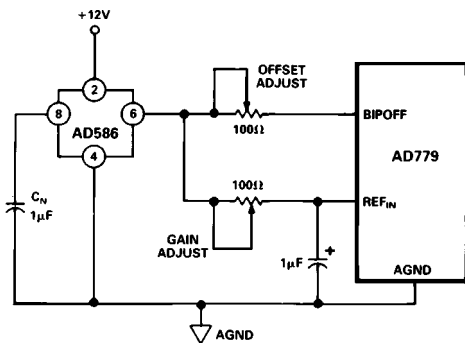

Figure 7. Bipolar Input with Gain and Offset Trims

Figure 8 shows the AD779 in unipolar input mode with the AD588 reference. The AD588 output is accurate to 0.65 mV

from its value at 25°C over the 0°C to 70°C range. This results in a 0.06% FSR total gain drift for the AD779, which is a substantial improvement over the on-chip reference performance of 0.11% FSR. A noise-reduction network on Pins 4, 6 and 7 has been shown. The 1 μF capacitors form low pass filters with the internal resistance of the AD588 Zener and amplifier cells and external resistance. This reduces the high frequency noise of the AD588, providing optimum ac and dc performance of the AD779.

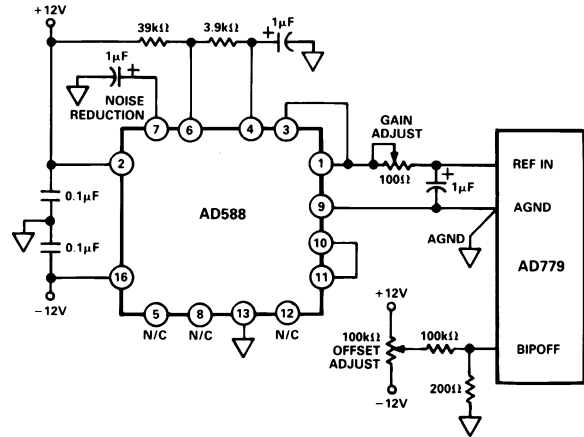

Figure 8. Unipolar Input with Gain and Offset Trims

## INTERFACING THE AD779 TO MICROPROCESSORS

The I/O capabilities of the AD779 allow direct interfacing to general purpose and DSP microprocessor buses. The asynchronous conversion control feature allows complete flexibility and control with minimal external hardware.

The following examples illustrate typical AD779 interface configurations.

### AD779 TO TMS320C25

In Figure 9 the AD779 is mapped into the TMS320C25 I/O space. AD779 conversions are initiated by issuing an OUT instruction to Port 1. EOC status and the conversion result are read in with an IN instruction to Port 1. A single wait state is inserted by generating the processor READY input from  $\overline{IS}$ , Port 1 and MSC. This configuration supports processor clock speeds of 20 MHz and is capable of supporting processor clock speeds of 40 MHz if a NOP instruction follows each AD779 read instruction.

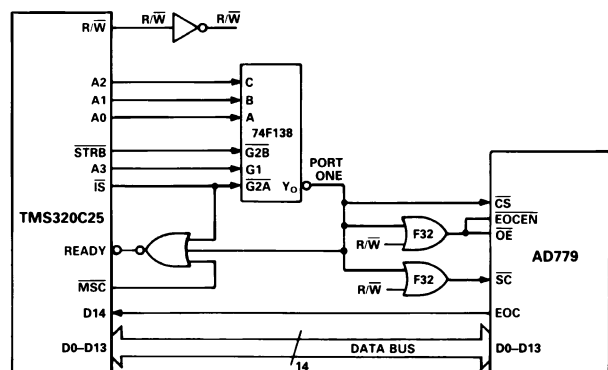

Figure 9. AD779 to TMS320C25 Interface

**AD779 TO 80186**

Figure 10 shows the AD779 interfaced to the 80186 microprocessor. This interface allows the 80186's built-in DMA controller to transfer the AD779 output into a RAM based FIFO buffer of any length, with no microprocessor intervention.

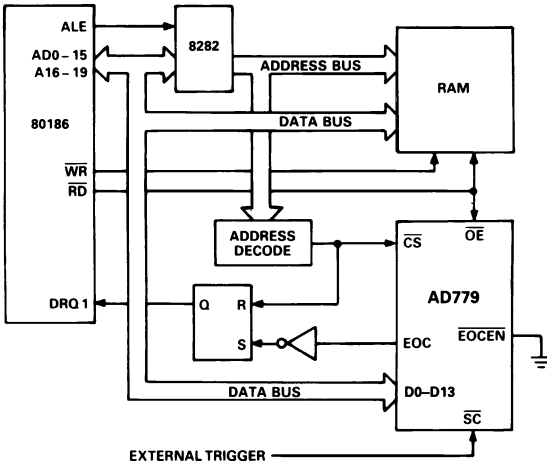

Figure 10. AD779 to 80186 DMA Interface

**AD779 TO Z80**

The AD779 can be interfaced to the Z80 processor in an I/O or memory mapped configuration. Figure 11 illustrates an I/O configuration, where the AD779 occupies several port addresses to allow separate polling of the EOC status and reading of the data.

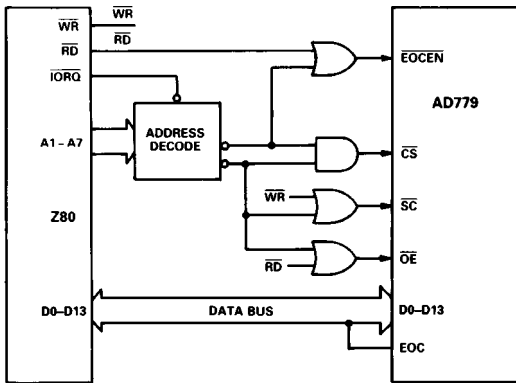

Figure 11. AD779 to Z80 Interface

A useful feature of the Z80 is that a single wait state is automatically inserted during I/O operations, allowing the AD779 to be used with Z80 processors having clock speeds up to 8 MHz.

The AD779 is asynchronous which allows conversions to be initiated by an external trigger source independent of the microprocessor clock. After each conversion, the AD779 EOC signal generates a DMA request to Channel 1 (DRQ1). The subsequent DMA READ resets the interrupt latch. The system designer must assign a sufficient priority to the DMA channel to ensure that the DMA request will be serviced before the completion of the next conversion. This configuration can be used with 6 MHz and 8 MHz 80186 processors.

**AD779 TO ANALOG DEVICES ADSP-2100A**

Figure 12 demonstrates the AD779 interfaced to an ADSP-2100A. With a clock frequency of 12.5 MHz, and instruction REV. B

execution in one 80 ns cycle, the digital signal processor will support the AD779 data memory interface with two wait states.

The converter runs asynchronously using a sampling clock. The EOC output to the AD779 gets asserted at the end of each conversion and causes an interrupt. Upon interrupt, the ADSP-2100A starts a data memory read by providing an address on the DMA bus. The decoded address generates OE for the converter. OE, together with logic and latch, is used to force the ADSP-2100A into a one cycle wait state by generating DMACK. The read operation is thus started and completed within two processor cycles (160 ns).

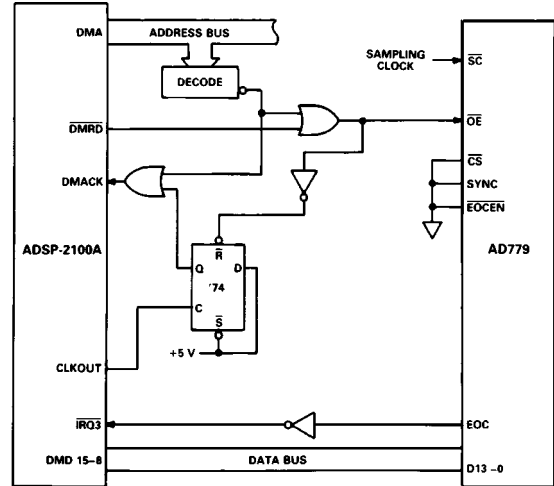

Figure 12. AD779 to ADSP-2100A Interface

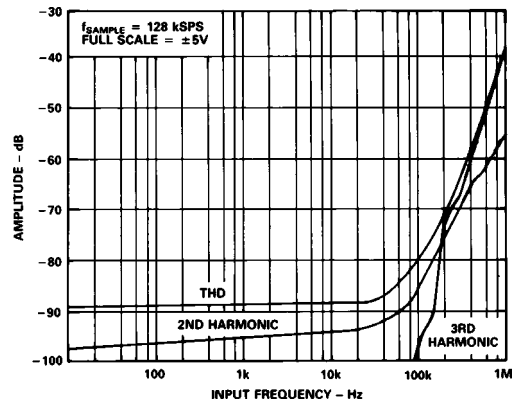

Figure 13. Harmonic Distortion vs. Input Frequency (0.5 dB Input)

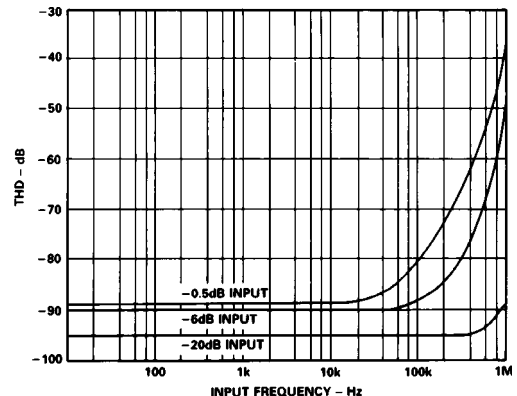

Figure 14. Total Harmonic Distortion vs. Input Frequency and Amplitude

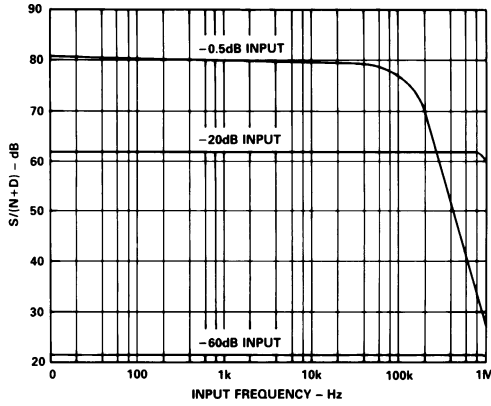

Figure 15.  $S/(N+D)$  vs. Input Frequency and Amplitude

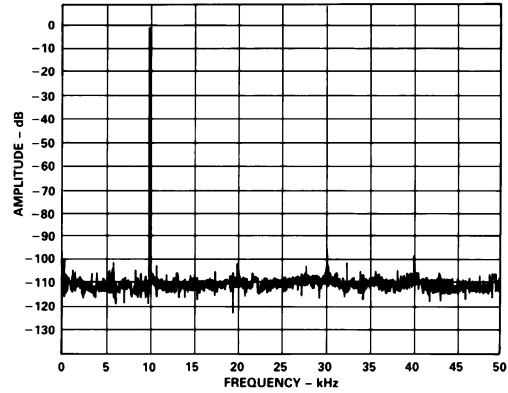

Figure 16. 5-Plot Averaged 2048-Point FFT at 128 kSPS,  $f_{IN} = 10.009$  kHz

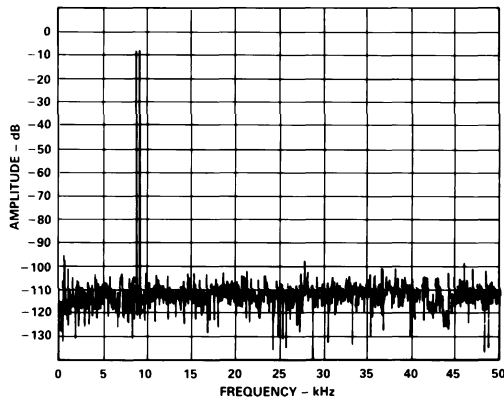

Figure 17. Nonaveraged IMD Plot for  $f_{IN} = 9.08$  kHz ( $f_a$ ), 9.58 kHz ( $f_b$ ) at 128 kSPS

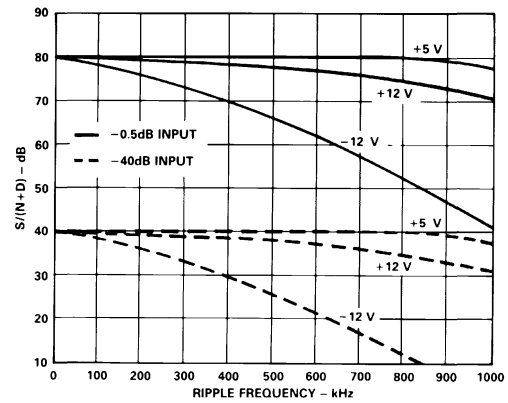
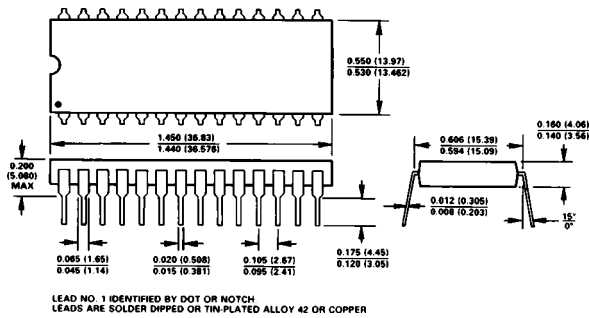

Figure 18. Power Supply Rejection ( $f_{IN} = 10$  kHz,  $f_{SAMPLE} = 128$  kSPS,  $V_{RIPPLE} = 0.1$  V p-p)

**OUTLINE DIMENSIONS**

Dimensions shown in inches and (mm).

**28-Lead Plastic DIP Package (N-28)**



**28-Lead Ceramic DIP Package (D-28)**

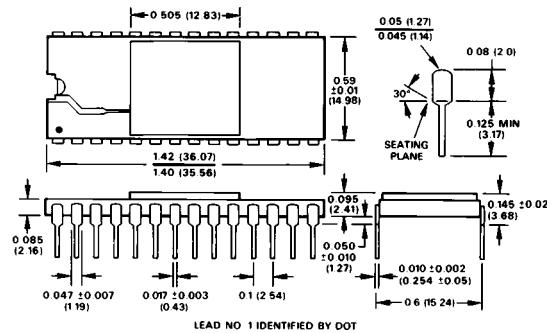

## Looking for pricing, stock, or lifecycle information?

Click below to explore more details on WIN SOURCE:

 [View AD779KNZ on WIN SOURCE](#)

 [Analog Devices Inc. Information](#)

## Optimize Your Supply Chain with WIN SOURCE Solutions

-  Global Sourcing Solution
-  Obsolete Management
-  Cost Control Management
-  Shortage Management
-  Alternative Solution
-  Excess Inventory Management