



**THE DATASHEET OF  
AD7872BRZ**



## FEATURES

**Complete monolithic 14-bit ADC**  
**Twos complement coding**  
**Parallel, byte, and serial digital interface**  
**80 dB SNR at 10 kHz input frequency**  
**57 ns data access time**  
**Low power: 50 mW typ**  
**83 kSPS throughput rate**

## APPLICATIONS

**Digital signal processing**  
**High speed modems**  
**Speech recognition and synthesis**  
**Spectrum analysis**  
**DSP servo control**

## GENERAL DESCRIPTION

The **AD7871/AD7872** are fast, complete, 14-bit analog-to-digital converters (ADC). They consist of a track-and-hold amplifier, successive approximation ADC, 3 V buried Zener reference, and versatile interface logic. The ADC features a self-contained, laser trimmed internal clock, so no external clock timing components are required. The on-chip clock may be overridden to synchronize ADC operation to the digital system for minimum noise.

The **AD7871** offers a choice of three data output formats: a single, parallel, 14-bit word; two 8-bit bytes or a 14-bit serial data stream. The **AD7872** is a serial output device only. The two parts are capable of interfacing to all modern microprocessors and digital signal processors.

The **AD7871/AD7872** operate from  $\pm 5$  V power supplies, accept bipolar input signals of  $\pm 3$  V and can convert full power signals up to 41.5 kHz.

In addition to the traditional dc accuracy specifications, the **AD7871/AD7872** are also fully specified for dynamic performance parameters including distortion and signal-to-noise ratio.

## FUNCTIONAL BLOCK DIAGRAMS

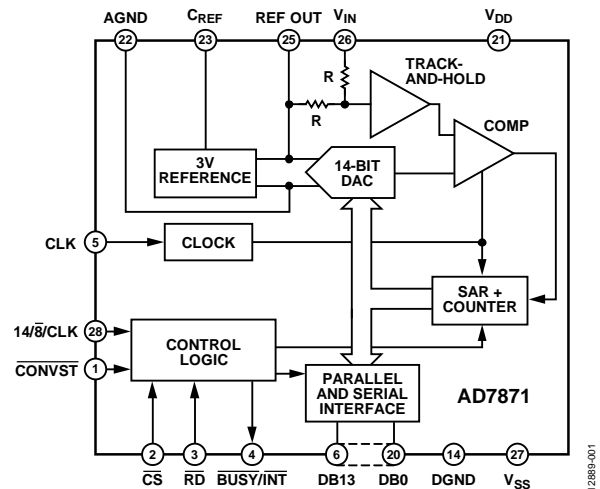

Figure 1.

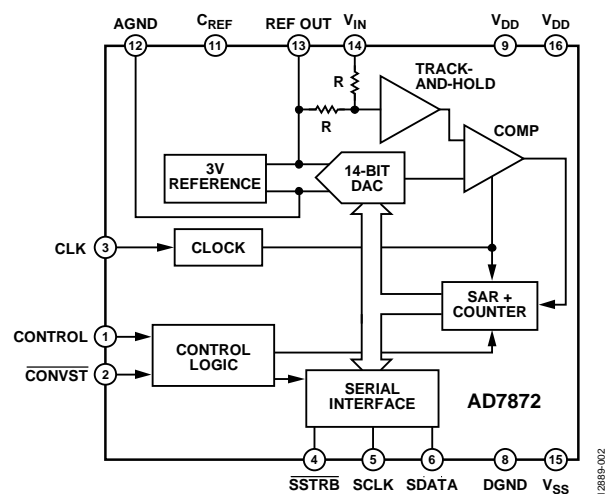

Figure 2.

Both devices are fabricated in Analog Devices, Inc., LC<sup>2</sup>MOS mixed technology process. The **AD7871** is available in 28-pin PDIP, PLCC, and CERDIP packages. The **AD7872** is available in a 16-pin PDIP, CERDIP, and SOIC packages.

## PRODUCT HIGHLIGHTS

1. Complete 14-Bit ADC on a Chip.
2. Dynamic Specifications for DSP Users.
3. Low Power.

Rev. F

[Document Feedback](#)

Information furnished by Analog Devices is believed to be accurate and reliable. However, no responsibility is assumed by Analog Devices for its use, nor for any infringements of patents or other rights of third parties that may result from its use. Specifications subject to change without notice. No license is granted by implication or otherwise under any patent or patent rights of Analog Devices. Trademarks and registered trademarks are the property of their respective owners.

## TABLE OF CONTENTS

Features .....	1	Unipolar Offset And Full-Scale Adjustment .....	11
Applications.....	1	Timing and Control .....	12
General Description .....	1	Data Output Formats.....	12
Functional Block Diagrams.....	1	Mode 1 Interface.....	13
Product Highlights .....	1	Mode 2 Interface.....	14
Revision History .....	2	Dynamic Specifications .....	15
Specifications.....	3	Microprocessor Interface .....	16
Timing Characteristics .....	5	StandAlone Operation.....	17
Absolute Maximum Ratings.....	6	Applications Information .....	18
ESD Caution.....	6	Layout Hints.....	18
Pin Configuration and Function Descriptions.....	7	Noise .....	18
Theory of Operation .....	10	Data Acquisition Board .....	18
Converter Details.....	10	Interface Connections .....	19
Internal Reference .....	10	Power Supply Connections .....	19
Track-And-Hold Amplifier .....	10	Shorting Plug Options .....	19
Analog Input .....	10	Outline Dimensions .....	22
Bipolar Offset Scale Adjustment .....	11	Ordering Guide .....	25
Unipolar Operation.....	11		

## REVISION HISTORY

### 11/2018—Rev. E to Rev. F

Change to Integral Nonlinearity, T Version Parameter, Table 1 .....	3
Added Figure 6; Renumbered Sequentially .....	7
Added Figure 9.....	9
Changes to Ordering Guide .....	24

### 1/2015—Rev. D to Rev. E

Updated Format.....	Universal
Changed T Version Minimum SNR from 79 dB to 77 dB and	
Changed T Version Maximum INL from $\pm 1$ LSB to $\pm 1.3$ LSB...	3
Deleted ADSP-2100 and TMS32020/C25 (Throughout).....	15
Deleted DSP56000 and ADSP-2101/ADSP-2102 (Throughout)...	16
Updated Outline Dimensions .....	21
Changes to Ordering Guide .....	24

### 1/1997—Rev. C to Rev. D

## SPECIFICATIONS

$V_{DD} = +5\text{ V} \pm 5\%$ ,  $V_{SS} = -5\text{ V} \pm 5\%$ ,  $AGND = DGND = 0\text{ V}$ ,  $f_{CLK} = 2\text{ MHz}$  external,  $f_{SAMPLE} = 83\text{ kHz}$ , all specifications  $T_{MIN}$  to  $T_{MAX}$ ; unless otherwise noted.

Table 1.

Parameter	J, A Versions <sup>1</sup>	K Version <sup>1</sup>	B Version <sup>1</sup>	T Version <sup>1</sup>	Unit	Test Conditions/Comments
<b>DYNAMIC PERFORMANCE<sup>2</sup></b>						
Signal-to-Noise Ratio <sup>3</sup> (SNR) at +25°C	80	80	79	77	dB min	$V_{IN} = 10\text{ kHz}$ sine wave
$T_{MIN}$ to $T_{MAX}$	80	80	79	77	dB min	
Total Harmonic Distortion (THD)	-86	-88			dB max	$V_{IN} = 10\text{ kHz}$ sine wave
Peak Harmonic or Spurious Noise	-86	-88	-85	-85	dB typ dB max	$V_{IN} = 10\text{ kHz}$
Intermodulation Distortion (IMD) Second-Order Terms	-86	-88	-85	-85	dB typ dB max	$f_a = 9\text{ kHz}$ , $f_b = 9.5\text{ kHz}$ , $f_{SAMPLE} = 50\text{ kHz}$
Third-Order Terms	-86	-88	-85	-85	dB typ dB max	$f_a = 9\text{ kHz}$ , $f_b = 9.5\text{ kHz}$ , $f_{SAMPLE} = 50\text{ kHz}$
Track/Hold Acquisition Time	2	2	-85 2	-85 2	dB typ $\mu\text{s}$ max	
<b>DC ACCURACY</b>						
Resolution	14	14	14	14	Bits	
Minimum Resolution for Which No Missing Codes Are Guaranteed	14	14	14	14	Bits	
Integral Nonlinearity at +25°C		$\pm\frac{1}{2}$	$\pm\frac{1}{2}$	$\pm\frac{1}{2}$	LSB typ	
Integral Nonlinearity		$\pm 1$	$\pm 1$	$\pm 2$	LSB max	
Bipolar Zero Error	$\pm 12$	$\pm 12$	$\pm 12$	$\pm 12$	LSB max	
Positive Gain Error <sup>4</sup>	$\pm 12$	$\pm 12$	$\pm 12$	$\pm 12$	LSB max	
Negative Gain Error <sup>4</sup>	$\pm 12$	$\pm 12$	$\pm 12$	$\pm 12$	LSB max	
<b>ANALOG INPUT</b>						
Input Voltage Range	$\pm 3$	$\pm 3$	$\pm 3$	$\pm 3$	V	
Input Current	$\pm 500$	$\pm 500$	$\pm 500$	$\pm 500$	$\mu\text{A}$ max	
<b>REFERENCE OUTPUT</b>						
REF OUT at +25°C	2.99/3.01	2.99/3.01	2.99/3.01	2.99/3.01	V min/V max	
$T_{MIN}$ to $T_{MAX}$	2.98/3.02	2.98/3.02	2.98/3.02	2.98/3.02	V min/V max	
REF OUT Tempco		$\pm 40$	$\pm 40$	$\pm 40$	ppm/°C max	Typically 35 ppm
Reference Load Sensitivity ( $\Delta\text{REF OUT}/\Delta I$ )	$\pm 1.2$	$\pm 1.2$	$\pm 1.2$	$\pm 1.2$	mV max	Reference load current change (0 $\mu\text{A}$ to 300 $\mu\text{A}$ ); reference load should not be changed during conversion
<b>LOGIC INPUTS</b>						
Input High Voltage, $V_{INH}$	2.4	2.4	2.4	2.4	V min	$V_{DD} = 5\text{ V} \pm 5\%$
Input Low Voltage, $V_{INL}$	0.8	0.8	0.8	0.8	V max	$V_{DD} = 5\text{ V} \pm 5\%$
Input Current, $I_{IN}$	$\pm 10$	$\pm 10$	$\pm 10$	$\pm 10$	$\mu\text{A}$ max	$V_{IN} = 0\text{ V}$ to $V_{DD}$
Input Current (14/8/CLK Input Only)	$\pm 10$	$\pm 10$	$\pm 10$	$\pm 10$	$\mu\text{A}$ max	$V_{IN} = V_{SS}$ to $V_{DD}$
Input Capacitance, $C_{IN}^5$	10	10	10	10	pF max	

Parameter	J, A Versions <sup>1</sup>	K Version <sup>1</sup>	B Version <sup>1</sup>	T Version <sup>1</sup>	Unit	Test Conditions/Comments
LOGIC OUTPUTS						
Output High Voltage, $V_{OH}$	4.0	4.0	4.0	4.0	V min	$I_{SOURCE} = 40 \mu A$ $I_{SINK} = 1.6 mA$
Output Low Voltage, $V_{OL}$	0.4	0.4	0.4	0.4	V max	
DB13 to DB0						
Floating-State Leakage Current	10	10	10	10	$\mu A$ max	
Floating-State Output Capacitance <sup>5</sup>	15	15	15	15	pF max	
CONVERSION TIME						
External Clock	10	10	10	10	$\mu s$ max	The internal clock has a nominal value of 2 MHz
Internal Clock	10.5	10.5	11	11	$\mu s$ max	
POWER REQUIREMENTS						
$V_{DD}$	+5	+5	+5	+5	V nom	$\pm 5\%$ for specified performance
$V_{SS}$	-5	-5	-5	-5	V nom	$\pm 5\%$ for specified performance
$I_{DD}$	13	13	13	13	mA max	Typically 6 mA
$I_{SS}$	6	6	6	6	mA max	Typically 4 mA
Power Dissipation	95	95	95	95	mW max	Typically 50 mW

<sup>1</sup> Temperature ranges are as follows: J, K versions, 0°C to +70°C; A, B versions, -40°C to +85°C; T version; -55°C to +125°C.

<sup>2</sup>  $V_{IN} = \pm 3 V$ .

<sup>3</sup> SNR calculation includes distortion and noise components.

<sup>4</sup> Measured with respect to internal reference.

<sup>5</sup> Sample tested at +25°C to ensure compliance.

**TIMING CHARACTERISTICS**

$V_{DD} = +5\text{ V} \pm 5\%$ ,  $V_{SS} = -5\text{ V} \pm 5\%$ ,  $AGND = DGND = 0\text{ V}$ . See Figure 16, Figure 17, Figure 18, and Figure 19.

**Table 2.**

Parameter <sup>1</sup>	Limit at $T_{MIN}, T_{MAX}$ (J, K, A, B Versions)	Limit at $T_{MIN}, T_{MAX}$ (T Version)	Unit	Test Conditions/Comments
$t_1$	50	50	ns min	$\overline{CONVST}$ pulse width
$t_2$	0	0	ns min	$\overline{CS}$ to $\overline{RD}$ setup time (Mode 1)
$t_3^2$	60	75	ns min	$\overline{RD}$ pulse width
$t_4$	0	0	ns min	$\overline{CS}$ to $\overline{RD}$ hold time (Mode 1)
$t_5$	70	70	ns min	$\overline{RD}$ to $\overline{INT}$ delay
$t_6^{2,3}$	57	70	ns max	Data access time after $\overline{RD}$
$t_7^{2,4}$	5	5	ns min	Bus relinquish time after $\overline{RD}$
	50	50	ns max	
$t_8$	0	0	ns min	HBEN to $\overline{RD}$ setup time
$t_9$	0	0	ns min	HBEN to $\overline{RD}$ hold time
$t_{10}$	100	100	ns min	$\overline{SSTRB}$ to SCLK falling edge setup time
$t_{11}^5$	440	440	ns min	SCLK cycle time
$t_{12}^6$	155	155	ns max	SCLK to VALID DATA DELAY; $C_L = 35\text{ pF}$
$t_{13}$	140	150	ns max	SCLK rising edge to $\overline{SSTRB}$
	20	20	ns min	
$t_{14}$	4	4	ns min	Bus relinquish time after SCLK
	100	100	ns max	
$t_{15}$	60	60	ns min	$\overline{CS}$ to $\overline{RD}$ setup time (Mode 2)
$t_{16}$	120	120	ns max	$\overline{CS}$ to $\overline{BUSY}$ propagation delay
$t_{17}^3$	200	200	ns min	Data set up time prior to $\overline{BUSY}$
$t_{18}$	0	0	ns min	$\overline{CS}$ to $\overline{RD}$ hold time (Mode 2)
$t_{19}$	0	0	ns min	HBEN to $\overline{CS}$ setup time
$t_{20}$	0	0	ns min	HBEN to $\overline{CS}$ hold time

<sup>1</sup> Serial timing is measured with a 4.7 k $\Omega$  pull-up resistor on  $\overline{SDATA}$  and  $\overline{SSTRB}$  and a 2 k $\Omega$  pull-up resistor on SCLK. The capacitance on all three outputs is 35 pF.

<sup>2</sup> These timing specifications are 100% production tested. All other times are sample tested at +25°C to ensure compliance. All input signals are specified with  $t_r = t_f = 5\text{ ns}$  (10% to 90% of 5 V) and timed from a voltage level of 1.6 V.

<sup>3</sup>  $t_6$  and  $t_{17}$  are measured with the load circuits of Figure 3 and defined as the time required for an output to cross 0.8 V or 2.4 V.

<sup>4</sup>  $t_7$  is derived from the measured time taken by the data outputs to change 0.5 V when loaded with the circuit of Figure 4. The measured number is then extrapolated back to remove the effects of charging or discharging the 50 pF capacitor. This means that the time,  $t_7$ , quoted in the Timing Characteristics is the true bus relinquish time of the part and is independent of bus loading.

<sup>5</sup> SCLK mark/space ratio (measured from a voltage level of 1.6 V) is 40/60 to 60/40.

<sup>6</sup>  $\overline{SDATA}$  will drive higher capacitive loads, but this will add to  $t_{12}$  because it increases the external RC time constant ( $4.7\text{ k}\Omega \parallel C_L$ ) and therefore the time to reach 2.4 V.

## ABSOLUTE MAXIMUM RATINGS

Table 3.

Parameter	Rating
$V_{DD}$ to AGND	−0.3 V to +7 V
$V_{SS}$ to AGND	+0.3 V to −7 V
AGND to DGND	−0.3 V to $V_{DD} + 0.3$ V
$V_{IN}$ to AGND	$V_{SS} - 0.3$ V to $V_{DD} + 0.3$ V
REF OUT, $C_{REF}$ to AGND	0 V to $V_{DD}$
Digital Inputs to DGND	−0.3 V to $V_{DD} + 0.3$ V
Digital Outputs to DGND	−0.3 V to $V_{DD} + 0.3$ V
Operating Temperature Range	
Commercial (J, K Versions)	0°C to +70°C
Industrial (A, B Versions)	−40°C to +85°C
Extended (T Version)	−55°C to +125°C
Storage Temperature Range	−65°C to +150°C
Lead Temperature (Soldering, 10 sec)	+300°C
Power Dissipation (Any Package) to +75°C	450 mW
Derates above +75°C by	6 mW/°C

Stresses at or above those listed under Absolute Maximum Ratings may cause permanent damage to the product. This is a stress rating only; functional operation of the product at these or any other conditions above those indicated in the operational section of this specification is not implied. Operation beyond the maximum operating conditions for extended periods may affect product reliability.

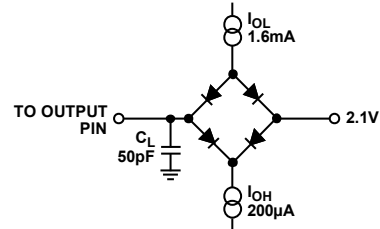

Figure 3. Load Circuit for Access Time

12889-003

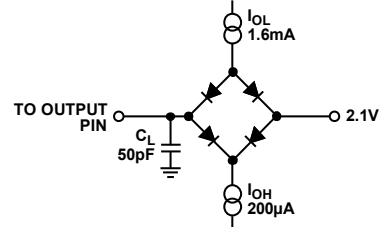

Figure 4. Load Circuit for Output Float Delay

12889-004

### ESD CAUTION



**ESD (electrostatic discharge) sensitive device.** Charged devices and circuit boards can discharge without detection. Although this product features patented or proprietary protection circuitry, damage may occur on devices subjected to high energy ESD. Therefore, proper ESD precautions should be taken to avoid performance degradation or loss of functionality.

# PIN CONFIGURATION AND FUNCTION DESCRIPTIONS

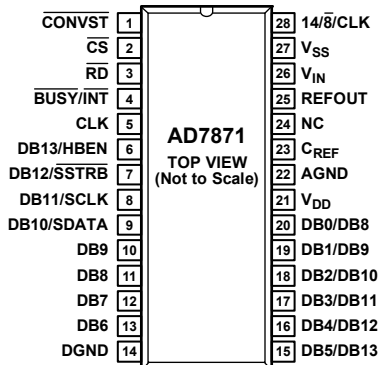

NOTES  
1. NC = NO CONNECT.

Figure 5. AD7871 PDIP

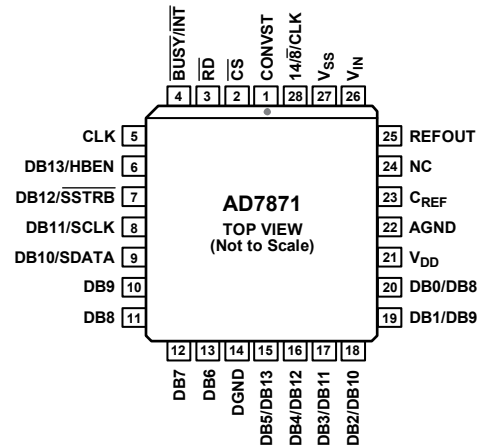

NOTES  
1. NC = NO CONNECT.

Figure 7. AD7871 PLCC

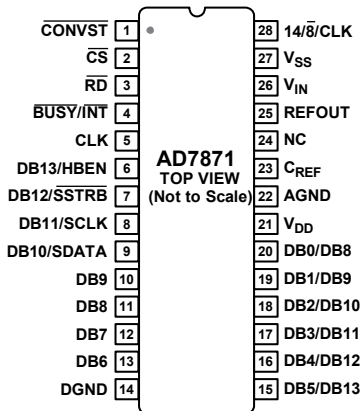

NOTES  
1. NC = NO CONNECT.

Figure 6. AD7871 CERDIP

Table 4. AD7871 Pin Function Descriptions

Pin No.	Mnemonic	Description
1	CONVST	Convert Start. A low to high transition on this input puts the track/hold into the hold mode. This input is asynchronous to the CLK. CS and RD must be held high for the duration of this pulse.
2	CS	Chip Select. Active low logic input. The device is selected when this input is active. With CONVST tied low, a new conversion is initiated when CS goes low.
3	RD	Read. Active low logic input. This input is used in conjunction with CS low to enable the data outputs.
4	BUSY/INT	Busy/Interrupt. Logic low output indicating converter status. See Figure 16, Figure 17, Figure 18, and Figure 19.
5	CLK	Clock Input. An external TTL-compatible clock may be applied to this input. Alternatively, tying this pin to VSS enables the internal laser-trimmed oscillator.
6	DB13/HBEN	Data Bit 13 (MSB)/High Byte Enable. The function of this pin is dependent on the state of the 14/8/CLK input (see Pin 28). When 14-bit data is selected, this pin provides the DB13 output. When either byte or serial data is selected, this pin becomes the HBEN logic input. HBEN is used for 8-bit bus interfacing. When HBEN is low, DB7 to DB0 is the lower byte of data. With HBEN high, DB7 to DB0 is the upper byte of data (see Table 5).
7	DB12/SSTRB	Data Bit 12/Serial Strobe. When 14-bit data is selected, this pin provides the DB12 data output. Otherwise, it is an active low three-state output that provides a framing pulse for serial data.
8	DB11/SCLK	Data Bit 11/Serial Clock. When 14-bit data is selected, this pin provides the DB11 data output. Otherwise, SCLK is the gated serial clock output that is derived from the internal or external ADC clock. If the 14/8/CLK input is held at -5 V, then the SCLK runs continuously. With 14/8/CLK at 0 V, it is gated off (three-state) after serial transmission

Pin No.	Mnemonic	Description
9	DB10/SDATA	is complete. Data Bit 10/Serial Data. When 14-bit parallel data is selected, this pin provides the DB10 data output. Otherwise, it is the three-state serial data output used in conjunction with SCLK and SSTRB in serial data transmission. Serial data is valid on the falling edge of SCLK, when SSTRB is low.
10 to 13	DB9 to DB6	Three-State Data Outputs controlled by CS and RD. Their function depends on the state of the 14/8/CLK and the HBEN inputs. With 14/8/CLK high, they are always DB9 to DB6; with 14/8/CLK low, their function depends on HBEN (see Table 5).
14	DGND	Digital Ground. Ground return for digital circuitry.
15 to 20	DB5/DB13 to DB0/DB8	Three-State Data Outputs controlled by CS and RD. Their function depends on the 14/8/CLK DB0/DB8 and HBEN inputs. With 14/8/CLK high, they are always DB5 to DB0; with 14/8/CLK low or -5 V, their function is controlled by HBEN (see Table 5).
21	VDD	Positive Supply, +5 V ± 5%.
22	AGND	Analog Ground. Ground reference for analog circuitry.
23	CREF	Decoupling Point for On-Chip Reference. Connect a 10 nF capacitor between this pin and AGND.
24	NC	No Connect.
25	REFOUT	Voltage Reference Output. The internal 3 V reference is provided at this pin. The external load capability is 500 μA.
26	VIN	Analog Input. The input range is ±3 V.
27	VSS	Negative Supply, -5 V ± 5%.
28	14/8/CLK	Three-Function Input. Defines both the parallel and serial data formats. With this pin at +5 V, the output data is 14-bit parallel only. With this pin at 0 V, both byte and serial data are available, and the SCLK is noncontinuous. With this pin at -5 V, both byte and serial data are available and the SCLK is continuous.

Table 5. Byte Output Format

HBEN	DB7	DB6	DB5	DB4	DB3	DB2	DB1	DB0
HIGH	LOW	LOW	DB13	DB12	DB11	DB10	DB9	DB8
LOW	DB7	DB6	DB5	DB4	DB3	DB2	DB1	DB0

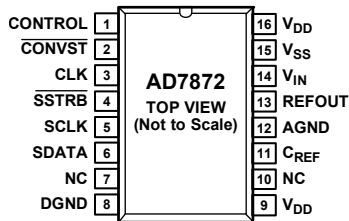

NOTES  
1. NC = NO CONNECT.

Figure 8. AD7872 PDIP, SOIC

128895-007

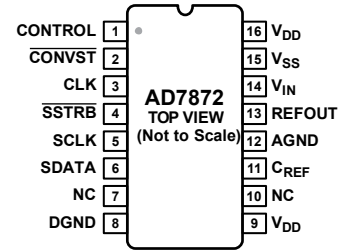

NOTES  
1. NC = NO CONNECT.

Figure 9. AD7872 CERDIP

128895-101

Table 6. AD7872 Pin Function Descriptions

Pin No.	Mnemonic	Description
1	CONTROL	Control Input. With this pin at 0 V, the SCLK is noncontinuous; with this pin at $-5$ V, the SCLK is continuous.
2	CONVST	Convert Start. A low to high transition on this input puts the track/hold into the hold mode. This input is asynchronous to the CLK.
3	CLK	Clock Input. An external TTL-compatible clock may be applied to this input. Alternatively, tying this pin to $V_{SS}$ enables the internal laser-trimmed oscillator.
4	SSTRB	Serial Strobe. This is an active low three-state output that provides a framing pulse for serial data. An external $4.7$ k $\Omega$ pull-up resistor is required on SSTRB.
5	SCLK	Serial Clock. SCLK is the gated serial clock output derived from the internal or external ADC clock. If the $14/8$ /CLK input is at $-5$ V, then the SCLK runs continuously. With CONTROL at 0 V, it is gated off (three-state) after the serial transmission is complete. SCLK is an open-drain output and requires an external $2$ k $\Omega$ pull-up resistor.
6	SDATA	Serial Data. This is the three-state serial data output used in conjunction with SCLK and SSTRB in a serial data transmission. Serial data is valid on the falling edge of SCLK, when SSTRB is low. An external $4.7$ k $\Omega$ pull-up resistor is required on SDATA.
7	NC	No Connect.
8	DGND	Digital Ground. Ground return for digital circuitry.
9	V <sub>DD</sub>	Positive Supply for Analog Circuitry, $+5$ V $\pm$ 5%.
10	NC	No Connect.
11	C <sub>REF</sub>	Decoupling Point for On-Chip Reference. Connect a $10$ nF capacitor between this pin and AGND.
12	AGND	Analog Ground. Ground reference for analog circuitry.
13	REFOUT	Voltage Reference Output. The internal $3$ V reference is provided at this pin. The external load capability is $500$ $\mu$ A.
14	V <sub>IN</sub>	Analog Input. The input range is $\pm 3$ V.
15	V <sub>SS</sub>	Negative Supply, $-5$ V $\pm$ 5%.
16	V <sub>DD</sub>	Positive Supply for Analog Circuitry, $+5$ V $\pm$ 5%. Connect Pin 16 and Pin 9 together.

## THEORY OF OPERATION

### CONVERTER DETAILS

The AD7871/AD7872 is a complete 14-bit ADC, requiring no external components apart from power supply decoupling capacitors. It is comprised of a 14-bit successive approximation ADC based on a fast settling voltage-output DAC, a high speed comparator and CMOS SAR, a track-and-hold amplifier, a 3 V buried Zener reference, a clock oscillator, and control logics.

### INTERNAL REFERENCE

The AD7871/AD7872 have an on-chip temperature compensated buried Zener reference that is factory trimmed to  $3\text{ V} \pm 0\text{ mV}$ . Internally it provides both the DAC reference and the dc bias required for bipolar operation. Reference noise is minimized by connecting a capacitor between  $C_{\text{REF}}$  and AGND. For specified operation this capacitor should be 10 nF. The reference output is available (REF OUT) and capable of providing up to 500  $\mu\text{A}$  to an external load.

The maximum recommended capacitance on REF OUT for normal operation is 50 pF. If the reference is required for use external to the AD7871/AD7872, decouple it with a 200  $\Omega$  resistor in series with a parallel combination of a 10  $\mu\text{F}$  tantalum capacitor and a 0.1  $\mu\text{F}$  ceramic capacitor. These decoupling components are required to remove voltage spikes caused by the internal operation of the AD7871/AD7872.

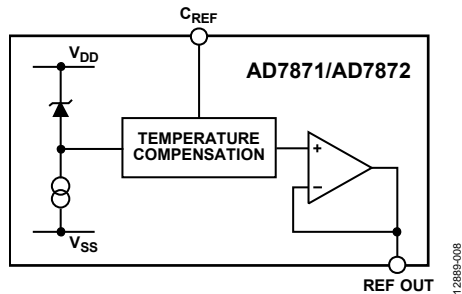

Figure 10. Reference Circuit

### TRACK-AND-HOLD AMPLIFIER

The track-and-hold amplifier on the analog input of the AD7871/AD7872 allows the ADC to accurately convert an input sine wave of 6 V peak-peak amplitude to 14-bit accuracy. The input bandwidth of the track-and-hold amplifier is much greater than the Nyquist rate of the ADC even when the ADC is operated at its maximum throughput rate. The 0.1 dB cutoff frequency occurs typically at 500 kHz. The track-and-hold amplifier acquires an input signal to 14-bit accuracy in less than 2  $\mu\text{s}$ . The overall throughput rate is determined by the conversion time plus the track-and-hold amplifier acquisition time. For a 2 MHz input clock, the throughput time is 12  $\mu\text{s}$  maximum.

The operation of the track-and-hold amplifier is essentially transparent to the user. The track-and-hold amplifier goes from its tracking mode to its hold mode at the start of conversion. If the CONVST input is used to start conversion, then the track to hold transition occurs on the rising edge of CONVST. If CS on the AD7871 starts conversion, this transition occurs on the falling edge of CS.

### ANALOG INPUT

Figure 11 shows the AD7871/AD7872 analog input. The analog input range is  $\pm 3\text{ V}$  into an input resistance of typically 15 k $\Omega$ . The designed code transitions occur midway between successive integer LSB values (that is, 1/2 LSB, 3/2 LSBs, 5/2 LSBs . . . FS - 3/2 LSBs). The output code is twos-complement binary with 1 LSB =  $\text{FS}/16384 = 6\text{ V}/16384 = 366\text{ }\mu\text{V}$ . The ideal input/output transfer function is shown in Figure 12.

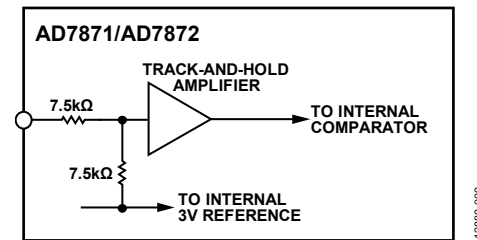

Figure 11. Analog Input

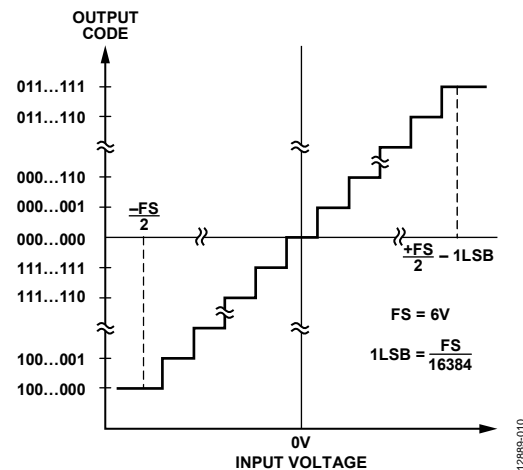
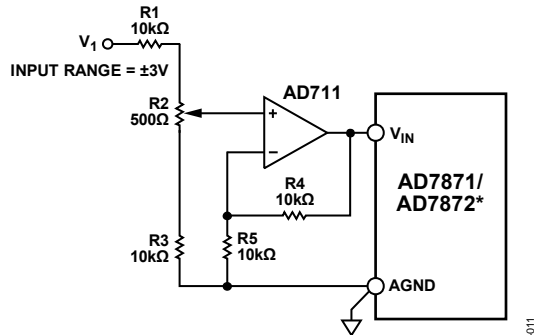

Figure 12. Bipolar Input/Output Transfer Function

### BIPOLAR OFFSET SCALE ADJUSTMENT

When the offset and full-scale errors of the AD7871/AD7872 need to be adjusted, offset error must be adjusted first. This is achieved by trimming the offset of the op amp driving the analog input of the AD7871/AD7872 while the input voltage is 1/2 LSB below AGND. The trim procedure is as follows: apply a voltage of -0.183 mV (-1/2 LSB) at V<sub>I</sub> in Figure 13 and adjust the op amp offset voltage until the ADC output code flickers between 11 1111 1111 1111 and 00 0000 0000 0000.



\*ADDITIONAL PINS OMITTED FOR CLARITY.  
Figure 13. Bipolar Adjust Circuit

Gain error can be adjusted at either the first code transition (ADC negative full scale) or the last code transition (ADC positive full scale). The trim procedures for both cases are in the following sections (see Figure 13).

#### Positive Full-Scale Adjust

Apply a voltage of 2.9995 V (FS/2 - 3/2 LSBs) at V<sub>I</sub> and adjust R2 until the ADC output code flickers between 01 1111 1111 1110 and 01 1111 1111 1111.

#### Negative Full-Scale Adjust

Apply a voltage of -2.9998 V (-FS/2 + 1/2 LSB) at V<sub>I</sub> and adjust R2 until the ADC output code flickers between 10 0000 0000 0000 and 10 0000 0000 0001.

### UNIPOLAR OPERATION

A typical unipolar circuit is shown in Figure 14. The AD7871/AD7872 REF OUT is used to offset the analog input by 3 V. The analog input range is determined by the ratio of R3 to R4. The minimum range with which the circuit will work is 0 V to 3 V. The resistor values are given in Figure 14 for input ranges of 0 to 5 V and 0 to 10 V. R5 and R6 are included for offset and full scale adjust only and should be omitted if adjustment is not required.

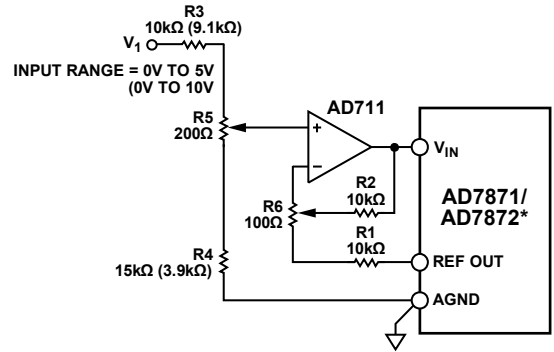

\*ADDITIONAL PINS OMITTED FOR CLARITY.  
Figure 14. Unipolar Circuit

The ideal input/output transfer function is shown in Figure 15. The output can be converted to straight binary by inverting the MSB.

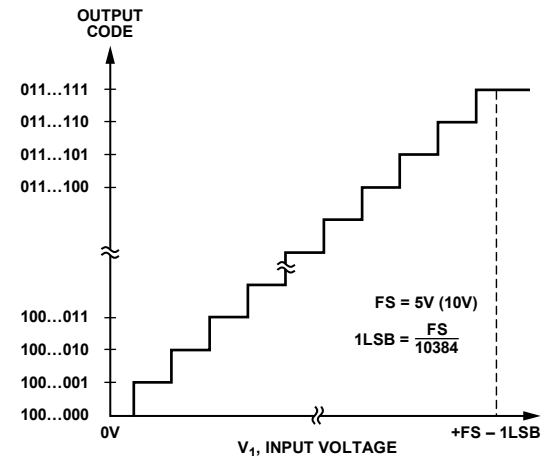

Figure 15. Unipolar Transfer Function

### UNIPOLAR OFFSET AND FULL-SCALE ADJUSTMENT

When absolute accuracy is required, offset and full-scale error can be adjusted to zero. Offset must be adjusted before full scale. This is achieved by applying an input voltage of 1/2 LSB to V<sub>I</sub> and adjusting R6 until the ADC output code flickers between 10 0000 0000 0000 and 10 0000 0000 0001. For full-scale adjustment, apply an input voltage of (FS - 3/2 LSBs) to V<sub>I</sub> and adjust R5 until the output code flickers between 01 1111 1111 1110 and 01 1111 1111 1111.

## TIMING AND CONTROL

The conversion time for both external and internal clocks can vary from 19 to 20 rising clock edges depending on the conversion start to ADC clock synchronization. If a conversion is initiated within 30 ns prior to a rising edge of the ADC clock, the conversion time will consist of 20 rising clock edges.

There are two basic operating modes for the AD7871. In the first mode (Mode 1), the  $\overline{\text{CONVST}}$  line is used to start a conversion and drive the track/hold into its hold mode. At the end of the conversion, the track/hold returns to its tracking mode. It is principally intended for digital signal processing and other applications where precise sampling in time is required. In these applications, it is important that the signal sampling occurs at exactly equal intervals to minimize errors due to sampling uncertainty or jitter. For these cases, the  $\overline{\text{CONVST}}$  line is driven by a timer or some precise clock source.

The second mode is achieved by hard-wiring the  $\overline{\text{CONVST}}$  line low. This mode (Mode 2) is intended for use in systems where the microprocessor has total control of the ADC, both initiating the conversion and reading the data.  $\overline{\text{CS}}$  and  $\overline{\text{RD}}$  start a conversion, and the microprocessor will normally be driven into a wait state for the duration of conversion by  $\overline{\text{BUSY/INT}}$ . The AD7872 has one operating mode only: Mode 1, which uses  $\overline{\text{CONVST}}$  to start conversion.

## DATA OUTPUT FORMATS

The AD7871 offers a choice of three data output formats: one serial and two parallel. The parallel data formats include a single 14-bit parallel word for 16-bit data buses and a two-byte format for 8-bit data buses. The data format is controlled by the  $14/8/\overline{\text{CLK}}$  input. A logic high on this pin selects the 14-bit parallel output format only. A logic low or  $-5\text{ V}$  applied to this pin allows the user access to either serial or byte formatted data. Three of the pins previously assigned to the four MSBs in parallel form are now used for serial communications while the fourth pin becomes a control input for the byte-formatted data. The three possible data output formats can be selected in either of the modes of operation.

The AD7872 is a serial output device only. The serial data format is exactly the same as the AD7871.

## Parallel Output Format

The two parallel formats available on the AD7871 are a 14-bit wide data word and a 2-byte data word. In the first, all 14 bits of data are available at the same time on DB13 (MSB) through DB0 (LSB). In the second, two reads are required to access the data. When this data format is selected, the DB13/HBEN pin assumes the HBEN function. HBEN selects which byte of data is to be read from the AD7871. When HBEN is low, the lower eight bits of data are placed on the data bus during a read operation; with HBEN high, the upper six bits of the 14-bit word are placed on the data bus. These six bits are right justified and thereby occupy the lower six bits of the byte while the upper two bits are zeros.

## Serial Output Format

Serial data is available on the AD7871 when the  $14/8/\overline{\text{CLK}}$  input is at 0 V or  $-5\text{ V}$  and in this case the DB12/ $\overline{\text{SSTRB}}$ , DB11/ $\overline{\text{SCLK}}$  and DB10/ $\overline{\text{SDATA}}$  pins assume their serial functions. The AD7872 is a serial output device only. The serial function on both devices is identical. Serial data is available during conversion with a word length of 16 bits; two leading zeros, followed by the 14-bit conversion result starting with the MSB. The data is synchronized to the serial clock output (SCLK) and is framed by the serial strobe ( $\overline{\text{SSTRB}}$ ). Data is clocked out on a low to high transition of the serial clock and is valid on the falling edge of this clock while the  $\overline{\text{SSTRB}}$  output is low.  $\overline{\text{SSTRB}}$  goes low at the start of conversion and the first serial data bit (which is the first leading zero) is valid on the first falling edge of SCLK. All the serial lines are open-drain outputs and require external pull-up resistors.

The serial clock out is derived from the ADC master clock source which may be internal or external. Normally, SCLK is required during the serial transmission only. In these cases it can be shut down (that is, placed into three-state) at the end of the conversion to allow multiple ADCs to share a common serial bus. However, some serial systems require a serial clock that runs continuously. Both options are available on the AD7871 and AD7872. With the  $14/8/\overline{\text{CLK}}$  input on the AD7871 at  $-5\text{ V}$ , the serial clock (SCLK) runs continuously; when  $14/8/\overline{\text{CLK}}$  is at 0 V, SCLK goes into three-state at the end of transmission. The CONTROL pin on the AD7872 performs the same function. When this is at 0 V, SCLK is noncontinuous and when it is at  $-5\text{ V}$ , SCLK is continuous.

The SCLK,  $\overline{\text{SDATA}}$ , and  $\overline{\text{SSTRB}}$  lines are open-drain outputs. If these are required to drive capacitive loads in excess of 35 pF, buffering is recommended.

**MODE 1 INTERFACE**

A conversion is initiated by a low going pulse on the  $\overline{\text{CONVST}}$  input. The rising edge of this  $\overline{\text{CONVST}}$  pulse starts the conversion and drives the track-and-hold amplifier into its hold mode. The  $\overline{\text{BUSY/INT}}$  status output assumes its  $\overline{\text{INT}}$  function in this mode.  $\overline{\text{INT}}$  is normally high and goes low at the end of conversion. This  $\overline{\text{INT}}$  line can be used to interrupt the microprocessor. A read operation to the AD7871 accesses the data and the  $\overline{\text{INT}}$  line is reset high on the falling edge of  $\overline{\text{CS}}$  and  $\overline{\text{RD}}$ . The  $\overline{\text{CONVST}}$  input must be high when  $\overline{\text{CS}}$  and  $\overline{\text{RD}}$  are brought low for the AD7871 to operate correctly in this mode. It is important, especially in systems where the conversion start ( $\overline{\text{CONVST}}$ ) pulse is asynchronous to the microprocessor, to ensure that a parallel or byte data read is not attempted during a conversion. Trying to read data during a conversion can cause errors to the conversion in progress. Avoid pulsing the  $\overline{\text{CONVST}}$  line a second time before the conversion ends because it can cause errors in the conversion result. In applications where precise sampling is not critical, the  $\overline{\text{CONVST}}$  pulse can be generated from the microprocessor  $\overline{\text{WR}}$  line OR-gated with the AD7871  $\overline{\text{CS}}$  input. In some applications, depending on power supply turn-on time, the AD7871/AD7872 may perform a conversion on power-up. In this case, the  $\overline{\text{INT}}$  line on the AD7871 will power up low, and a dummy read to the device will be required to reset the  $\overline{\text{INT}}$  line before starting conversion.

Figure 16 shows the Mode 1 timing diagram for a 14-bit parallel data output format ( $14/8/\text{CLK} = 5 \text{ V}$ ). A read to the AD7871 at the end of conversion accesses all 14 bits of data at the same time. Serial data is not available for this data output format.

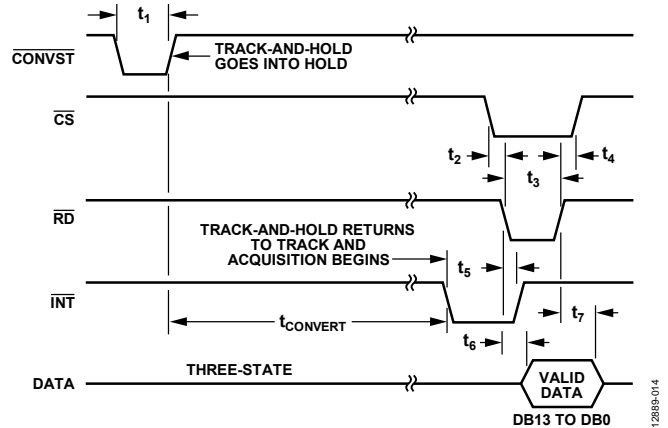
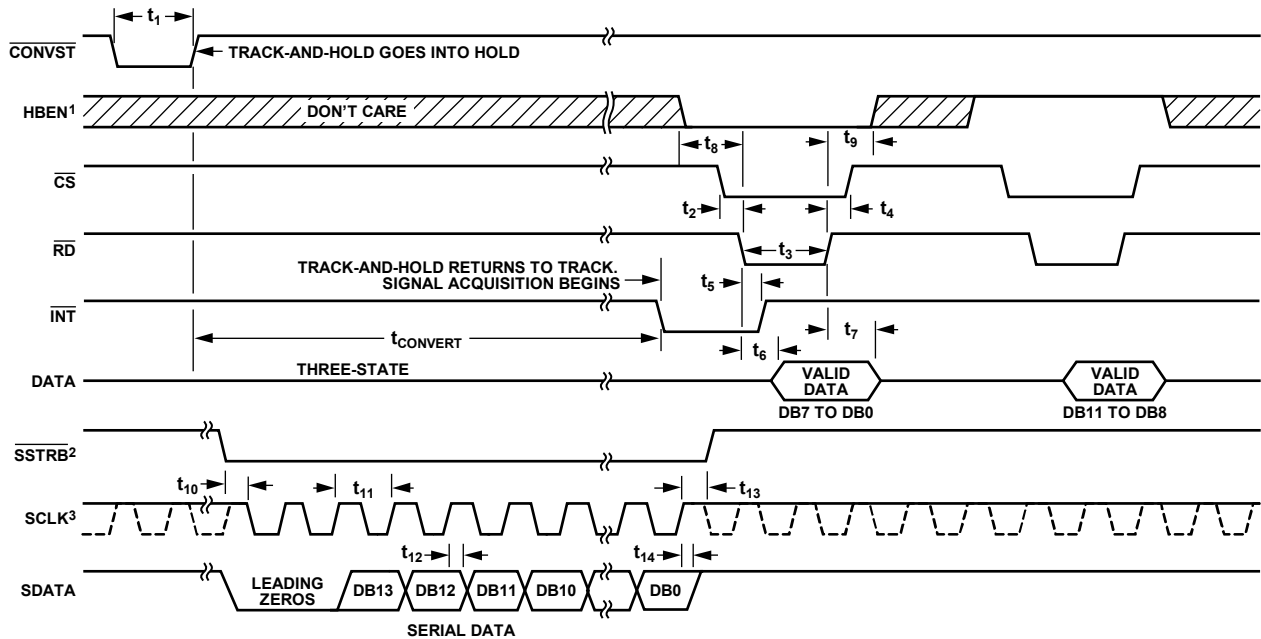

Figure 16. Mode 1 Timing Diagram, 14-Bit Parallel

The Mode 1 function timing diagram for byte and serial data is shown in Figure 17.  $\overline{\text{INT}}$  goes low at the end of conversion and is reset high by the first falling edge of  $\overline{\text{CS}}$  and  $\overline{\text{RD}}$ . This first read at the end of the conversion can either access the low byte or high byte of data depending on the status of  $\text{HBEN}$  (Figure 17 shows low byte for example only). The diagram shows both the  $\text{SCLK}$  output going into three-state at the end of transmission and a continuously running clock (dashed line).



<sup>1</sup>TIMES  $t_2$ ,  $t_3$ ,  $t_4$ ,  $t_8$ , AND  $t_9$  ARE THE SAME FOR A HIGH BYTE READ AS FOR A LOW BYTE READ.

<sup>2</sup>EXTERNAL 4.7k $\Omega$  PULL-UP RESISTOR.

<sup>3</sup>EXTERNAL 2k $\Omega$  PULL-UP RESISTOR. CONTINUOUS SCLK (DASHED LINE) WHEN  $14/8/\text{CLK}$  (CONTROL) = -5V; NONCONTINUOUS WHEN  $14/8/\text{CLK}$  (CONTROL) = 0V.

Figure 17. Mode 1 Timing Diagram, Byte or Serial Read

**MODE 2 INTERFACE**

The second interface mode is achieved by hard wiring  $\overline{\text{CONVST}}$  low and the conversion is initiated by taking  $\overline{\text{CS}}$  low while  $\text{HBEN}$  is low. The track-and-hold amplifier goes into the hold mode on the falling edge of  $\overline{\text{CS}}$ . In this mode, the  $\overline{\text{BUSY}}/\overline{\text{INT}}$  pin assumes its  $\overline{\text{BUSY}}$  function.  $\overline{\text{BUSY}}$  goes low at the start of the conversion, stays low during the conversion and returns high when the conversion is complete. It is normally used in parallel interfaces to drive the microprocessor into a wait state for the duration of conversion.

Figure 18 shows the Mode 2 timing diagram for the 14-bit parallel data output format ( $14/8/\text{CLK} = 5\text{ V}$ ). In this case, the ADC behaves like slow memory. The major advantage of this

interface is that it allows the microprocessor to start the conversion, wait and then read data with a single read instruction. The user does not have to worry about servicing interrupts or ensuring that software delays are long enough to avoid the reading during conversion.

The Mode 2 timing diagram for byte and serial data is shown in Figure 19. For 2-byte data read, the lower byte (DB0 to DB7) has to be accessed first because  $\text{HBEN}$  must be low to start the conversion. The ADC behaves like slow memory for this first read, but the second read to access the upper byte of data is a normal read. Operation to the serial functions is identical between Mode 1 and Mode 2. The timing diagram of Figure 19 shows  $\text{SCLK}$  going into three-state or running continuously (dashed line).

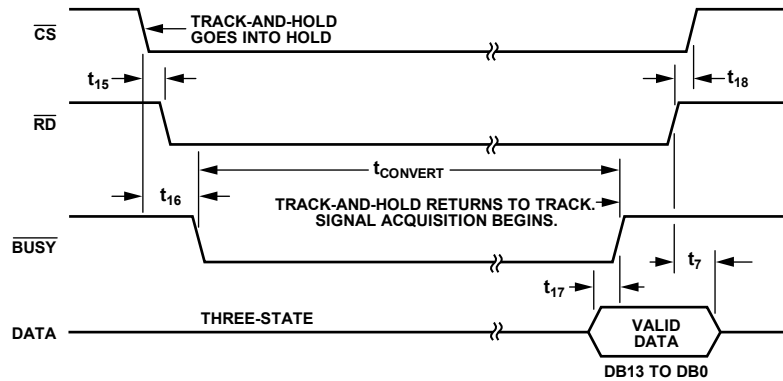
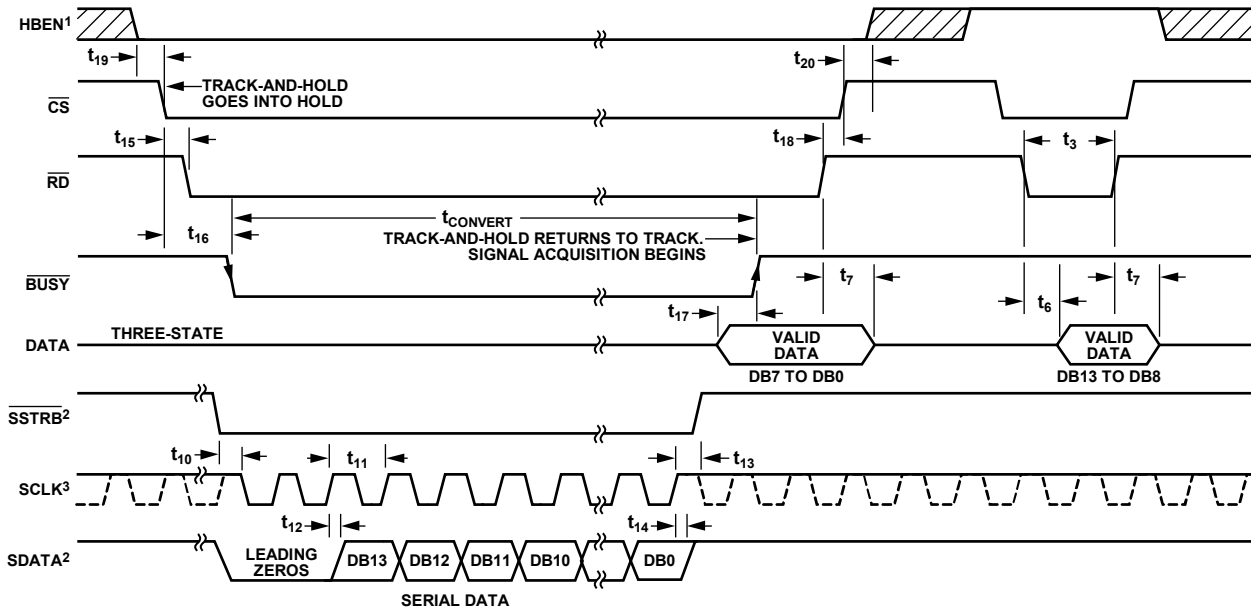

Figure 18. Mode 2 Timing Diagram, 14-Bit Parallel Read



<sup>1</sup>TIMES  $t_{15}$ ,  $t_{18}$ ,  $t_{19}$ ,  $t_8$ , AND  $t_{20}$  ARE THE SAME FOR A HIGH BYTE READ AS FOR A LOW BYTE READ.

<sup>2</sup>EXTERNAL 4.7kΩ PULL-UP RESISTOR.

<sup>3</sup>CONTINUOUS SCLK (DASHED LINE) WHEN  $14/8/\text{CLK}(\text{CONTROL}) = -5\text{V}$ ; NONCONTINUOUS WHEN  $14/8/\text{CLK}(\text{CONTROL}) = 0\text{V}$ . EXTERNAL 2kΩ PULL-UP RESISTOR.

Figure 19. Mode 2 Timing Diagram, Byte or Serial Read

**DYNAMIC SPECIFICATIONS**

The AD7871/AD7872 are specified and tested for dynamic performance specifications as well as traditional dc specifications such as INL and DNL. These ac specifications are required for signal processing applications such as speech recognition, spectrum analysis and high speed modems. These applications require information on the effects on the spectral content of the input signal. Therefore, the parameters for which the AD7871/AD7872 is specified include SNR, harmonic distortion, intermodulation distortion, and peak harmonics. These terms are discussed in more detail in the following sections.

**Signal-to-Noise Ratio (SNR)**

SNR is the measured signal-to-noise ratio at the output of the ADC. The signal is the rms magnitude of the fundamental. Noise is the rms sum of all the nonfundamental signals up to half the sampling frequency ( $f_s/2$ ) excluding dc. SNR is dependent upon the number of quantization levels used in the digitization process; the more levels, the smaller the quantization noise. The theoretical signal to noise ratio for a sine wave input is given by:

$$SNR(dB) = (6.02N + 1.76) \tag{1}$$

where  $N$  is the number of bits in the ADC. Thus, for an ideal 14-bit converter, SNR = 86 dB.

The output spectrum from the ADC is evaluated by applying a sine wave signal of very low distortion to the  $V_{IN}$  input, which is sampled at an 83 kHz sampling rate. A Fast Fourier Transform (FFT) plot is generated from which the SNR data can be obtained. Figure 20 shows a typical 2048 point FFT plot of the AD7871/AD7872, with an input signal of 10 kHz and a sampling frequency of 83 kHz. The SNR obtained from this graph is 80 dB. Note that the harmonics are included when calculating the SNR.

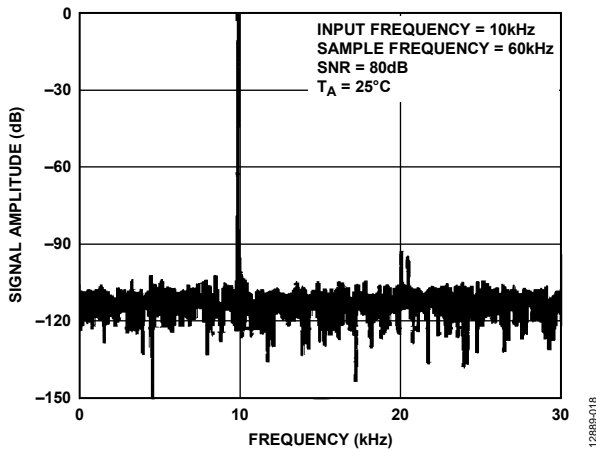

Figure 20. Fast Fourier Transform Plot

**Effective Number of Bits**

The formula given in Equation 1 relates the SNR to the number of bits. Rewriting the formula, as in Equation 2, it is possible to

get a measure of performance expressed in an effective number of bits ( $N$ ).

$$N = \frac{SNR - 1.76}{6.02} \tag{2}$$

The effective number of bits for a device can be calculated directly from its measured SNR. Figure 21 shows a typical plot of effective number of bits vs. frequency for the AD7871/AD7872 with a sampling frequency of 60 kHz.

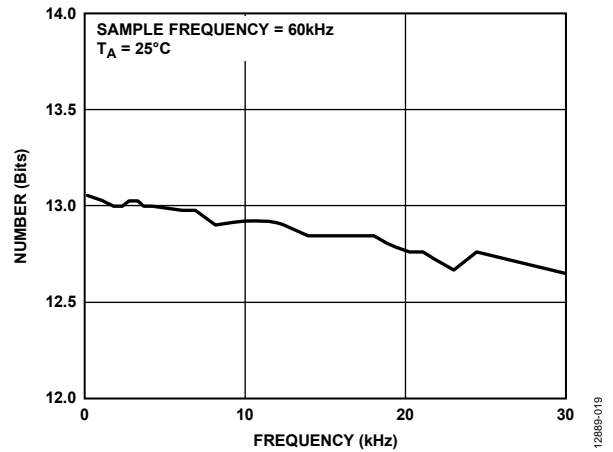

Figure 21. Effective Number of Bits vs. Frequency

**Harmonic Distortion**

Harmonic distortion is the ratio of the rms sum of harmonics to the fundamental. For the AD7871/AD7872, total harmonic distortion (THD) is defined as

$$THD(dB) = 20 \log \frac{\sqrt{V_2^2 + V_3^2 + V_4^2 + V_5^2 + V_6^2}}{V_1}$$

where:

$V_1$  is the rms amplitude of the fundamental.  
 $V_2, V_3, V_4, V_5$  and  $V_6$  are the rms amplitudes of the second through the sixth harmonic.

The THD is also derived from the FFT plot of the ADC output spectrum. Figure 22 shows how the THD varies with input frequency.

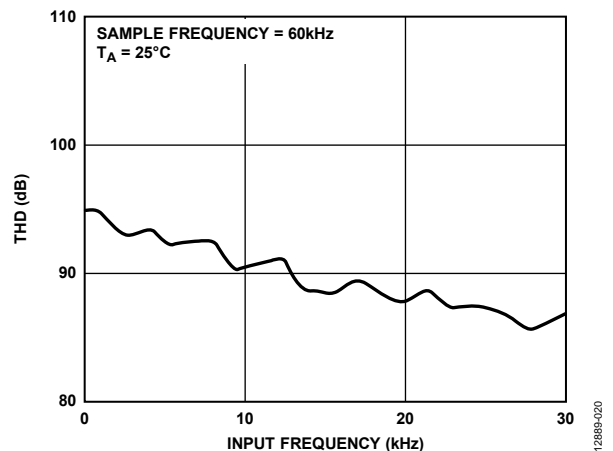

Figure 22. Total Harmonic Distortion vs. Frequency

### Intermodulation Distortion

With inputs consisting of sine waves at two frequencies,  $f_a$  and  $f_b$ , any active device with nonlinearities will create distortion products at sum and difference frequencies of  $m f_a \pm n f_b$  where  $m, n = 0, 1, 2, 3$ , etc. Intermodulation terms are those for which neither  $m$  nor  $n$  are equal to zero. For example, the second order terms include  $(f_a + f_b)$  and  $(f_a - f_b)$ , while the third order terms include  $(2f_a + f_b)$ ,  $(2f_a - f_b)$ ,  $(f_a + 2f_b)$  and  $(f_a - 2f_b)$ .

Using the CCIF standard where two input frequencies near the top end of the input bandwidth are used, the second- and third-order terms are of different significance. The second-order terms are usually distanced in frequency from the original sine waves while the third-order terms are usually at a frequency close to the input frequencies. As a result, the second- and third-order terms are specified separately. The calculation of the intermodulation distortion is as per the THD specification, where it is the ratio of the rms sum of the individual distortion products to the rms amplitude of the fundamental expressed in decibels. In this case, the input consists of two, equal amplitude, low distortion sine waves. Figure 23 shows a typical IMD plot for the AD7871/AD7872.

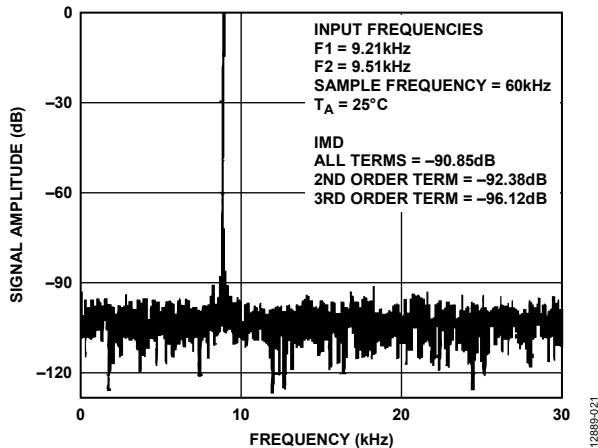

Figure 23. IMD Plot

### Peak Harmonic or Spurious Noise

Peak harmonic or spurious noise is defined as the ratio of the rms value of the next largest component in the ADC output spectrum (up to  $f_s/2$  and excluding dc) to the rms value of the fundamental. Normally, the value of this specification will be determined by the largest harmonic in the spectrum, but for parts where the harmonics are buried in the noise floor, peak will be a noise peak.

### MICROPROCESSOR INTERFACE

The AD7871/AD7872 have a wide variety of interfacing options. The AD7871 offers two operating modes and three data-output formats, while the AD7872 is a dedicated serial output device. The fast data access times on the parallel modes of the AD7871 allow interfacing to the very fast DSPs. The serial mode on both the AD7871 and AD7872 is compatible with the serial port structures on all the popular DSPs.

### Parallel Read Interfacing

Figure 24 and Figure 25 show interfaces to two different DSP processor types. The AD7871 is operating in Mode 1, parallel read for both interfaces. An external timer controls conversion start asynchronously to the microprocessor. At the end of each conversion the ADC BUSY/INT interrupts the microprocessor and the conversion result is read from the ADC with the following instruction:

DSP 1 MR0 = DM(ADC)

DSP 2: IN D,ADC

MR0 = DSP 1 MR0 Register

D = Data Memory Address

ADC = AD7871 Address

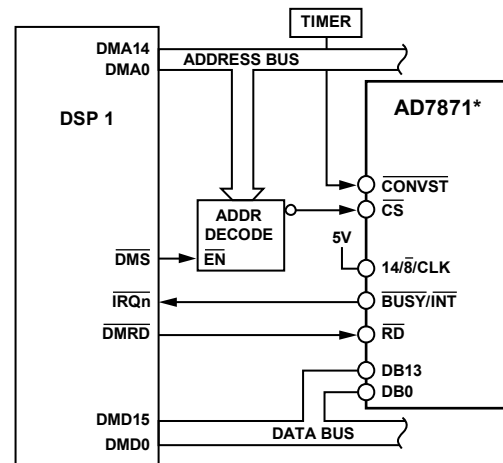

\*ADDITIONAL PINS OMITTED FOR CLARITY.

Figure 24. AD7871 to DSP 1 Parallel Interface

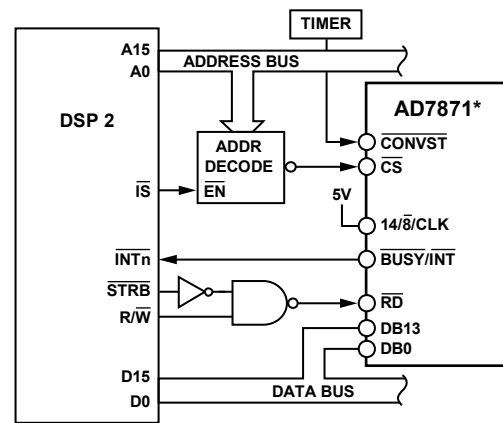

\*ADDITIONAL PINS OMITTED FOR CLARITY.

Figure 25. AD7871 to DSP 2 Interface

Some applications may require that conversions be initiated by the microprocessor rather than an external timer. One option is to decode the AD7871 CONVST from the address bus so that a write operation to the ADC starts a conversion. Data is read at the end of conversion as described previously. Note that a read operation must not be attempted during conversion.

**Serial Interfacing**

Both the AD7871 and the AD7872 have an identical serial interface. The diagrams that follow show the AD7872 interfaces only, but the AD7871 could just as easily be used in these circuits. Figure 26, Figure 27, and Figure 28 show the AD7872 connected to three popular DSPs. In all three interfaces, CONVST is used to start the conversion because this does not activate the parallel bus. Thus, the microprocessor can continue to use its parallel bus regardless of the state of the AD7872. The interfaces show a timer driving the CONVST input but this could be generated from a decoded address if required.

**AD7872 to DSP Type 1 Serial Interface**

Figure 26 shows a serial interface between the AD7872 and DSP Type 1. The interface arrangement is two-wire with the AD7872 configured for noncontinuous clock operation CONTROL = 0 V). DSP Type 1 is configured for normal mode asynchronous operation with gated clock. It is set up for a 16-bit word with SCK as an input and the FSL control bit set to a 0. In this configuration, the DSP Type 1 assumes valid data on the first falling edge of SCK. Because the AD7872 provides valid data on this first edge, there is no need for a strobe or framing pulse for the data. SCLK and SDATA are three-stated when the AD7872 is not performing a conversion. During conversion, data is valid on the SDATA output of the AD7872 and is clocked into the Receive Data Shift Register of DSP Type 1. When this register has received 16 bits of data, it generates an internal interrupt on DSP Type 1 to read the data from the register.

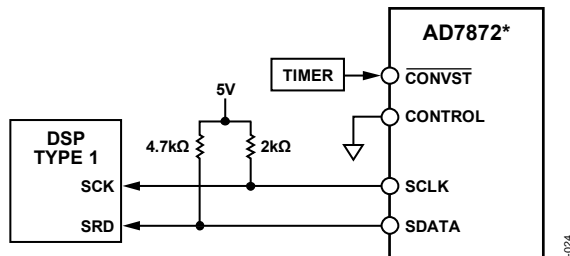

\*ADDITIONAL PINS OMITTED FOR CLARITY.

Figure 26. AD7872 to DSP Type 1 Interface

DSP Type 1 and AD7872 can also be configured for continuous clock operation. In this case a strobe pulse is required by DSP Type 1 to indicate when data is valid. The SSTRB output of the AD7872 is inverted and applied to the SC1 input of DSP Type 1 to provide this strobe pulse. All other conditions and connections are the same as for the gated clock operation.

**AD7872 to DSP Type 2 Serial Interface**

Figure 27 shows a serial interface between the AD7872 and DSP Type 2. The AD7872 is configured for continuous clock operation. Note that the ADC will not interface correctly to a DSP if it is configured for a noncontinuous clock. Data is clocked into the data receive register (DRR) of a DSP during conversion. As with the previous interfaces, when a 16-bit word is received by the DSP it generates an internal interrupt to read the data from the DRR.

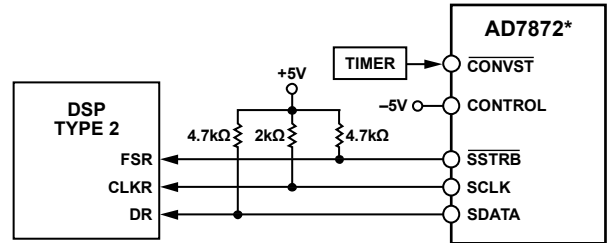

\*ADDITIONAL PINS OMITTED FOR CLARITY.

Figure 27. AD7872 to DSP Type 2 Interface

**AD7872 to a DSP Microcomputer Serial Interface**

Figure 28 shows a serial interface between the AD7872 and a DSP microcomputer. The AD7872 is configured for continuous clock operation. Data is clocked into the serial port register of the microcomputer during conversion. As with the previous interfaces, when a 16-bit data word is received by a DSP microcomputer an internal microprocessor interrupt is generated and the data is read from the serial port register.

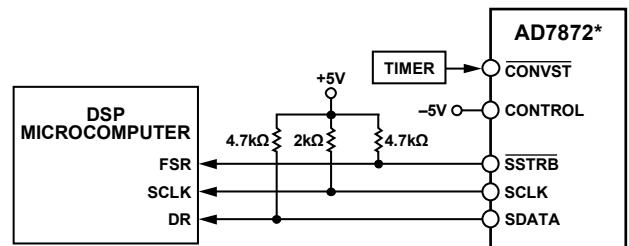

\*ADDITIONAL PINS OMITTED FOR CLARITY.

Figure 28. AD7872 to a DSP Microcomputer Serial Interface

**STANDALONE OPERATION**

The AD7871 can be used in its Mode 2, parallel mode for standalone operation. In this case, conversion is initiated with a pulse to the CS input. This pulse must be longer than the conversion time of the ADC. The BUSY output is used to drive the RD input. Data is latched from the AD7871 DB0 to DB11 outputs to an external latch on the rising edge of BUSY.

## APPLICATIONS INFORMATION

Good printed circuit board (PCB) layout is as important as the circuit design itself in achieving high speed ADC performance. The [AD7871/AD7872](#) is required to make bit decisions on an LSB size of 366  $\mu\text{V}$ . Thus, the designer has to be conscious of noise both in the ADC itself and in the preceding analog circuitry. Switching mode power supplies are not recommended as the switching spikes will feed through to the comparator causing noisy code transitions. Other causes of concern are ground loops and digital feedthrough from microprocessors. These are factors that influence any ADC; a proper PCB layout that minimizes these effects is essential for best performance.

### LAYOUT HINTS

Ensure that the layout for the PCB has the digital and analog signal lines separated as much as possible. Take care not to run a digital track alongside an analog signal track. Guard (screen) the analog input with AGND.

Establish a single point analog ground (star ground) separate from the logic system ground at the [AD7871/AD7872](#) AGND pin or as close as possible to the [AD7871/AD7872](#). Connect all other grounds and the [AD7871/AD7872](#) DGND to this single analog ground point. Do not connect any other digital grounds to this analog ground point.

Low impedance analog and digital power supply common returns are essential to low noise operation of the ADC, so make the foil width for these tracks as wide as possible. The use of ground planes minimizes impedance paths and also guards the analog circuitry from digital noise. The circuit layout of Figure 33 and Figure 34 have both analog and digital ground planes that are kept separated and joined together only at the [AD7871/AD7872](#) AGND pin.

### NOISE

Keep the input signal leads to  $V_{\text{IN}}$  and signal return leads from AGND as short as possible to minimize input noise coupling. In applications where this is not possible, use a shielded cable between the source and the ADC. Reduce the ground circuit impedance as much as possible because any potential difference in grounds between the signal source and the ADC appears as an error voltage in series with the input signal.

## DATA ACQUISITION BOARD

Figure 31 shows the [AD7871/AD7872](#) in a data acquisition circuit. The corresponding PCB layout has three interface ports: one serial and two parallel. Note that the [AD7871/AD7872](#) serial lines are buffered by a 74HC244. This allows long lines with large capacitive loads to be driven. One of the parallel ports is directly compatible with the DSP processor evaluation board expansion connector.

The only additional component required for a full data acquisition system is an antialiasing filter. There is a component grid provided near the analog input on the PCB, which may be used for such a filter or any other input conditioning circuitry. To facilitate this option, there is a shorting plug (labelled LK1 on the PCB) on the analog input track. If this shorting plug is used, the analog input connects to the buffer amplifier driving the [AD7871/AD7872](#); if this shorting plug is omitted, a wire link can be used to connect the analog input to the PCB component grid.

**INTERFACE CONNECTIONS**

There are two parallel connectors labeled SKT4 and SKT6, and one serial connector labeled SKT5. A shorting plug option (LK3 in Figure 31) configures the ADC for the appropriate interface.

SKT6 is a 96-contact (3-row) Eurocard connector that is directly compatible with the DSP processor evaluation board prototype expansion connector. The expansion connector on the DSP processor has eight decoded chip enable outputs labeled ECE1 to ECE8. ECE6 is used to drive the AD7871 CS input on the board. To avoid selecting the on-board RAM sockets at the same time, remove LK6 on the DSP processor board. In addition, the DSP processor expansion connector has four interrupts labelled EIRQ0 to EIRQ3. The AD7871 BUSY/INT output connects to EIRQ0. There is a single wait state generator connected to EDMACK to allow the AD7871 to interface to the faster versions of the DSP processor.

SKT4 is a 26-way (2-row) IDC connector. This contains the same signal contacts as SKT6 except for EDMACK, which is connected to SKT6 only. It also contains decoded R/W and STRB inputs necessary for DSP processor interfacing.

SKT5 is a 5-way D-type connector meant for serial interfacing only. An inverted DB11/SCLK output is also provided on this connector for systems that accept data on a rising clock edge.

SKT1, SKT2, and SKT3 are three BNC connectors providing connections for the analog input, the CONVST input and an external clock.

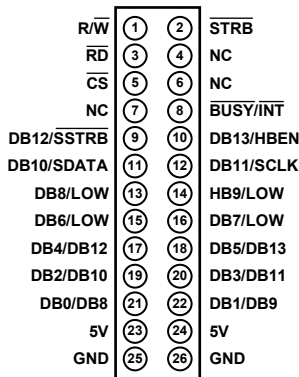

NC = NO CONNECT  
Figure 29. SKT4 Pinout

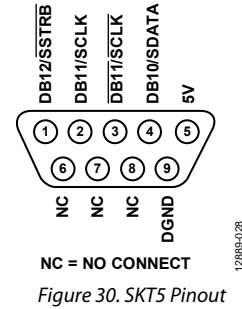

Figure 30. SKT5 Pinout

**POWER SUPPLY CONNECTIONS**

The PCB requires two analog power supplies and one 5 V logic supply. The analog supplies are labelled V+ and V-, and the range for both supplies is 12 V to 15 V. Connection to the 5 V digital supply is made through any of the SKT4 to SKT6 connectors. The ±5 V supply required by the AD7871/AD7872 is generated from voltage regulators on the V+ and V- power supplies input (IC6 and IC7 in Figure 31).

**SHORTING PLUG OPTIONS**

There are seven shorting plug options, which must be set before using the board. These are outlined in Table 7.

Table 7.

Plug	Description
LK1	Connects the analog input to a buffer amplifier. The analog input may also be connected to a component grid for signal conditioning.
LK2	Selects either the AD7871/AD7872 internal clock or an external clock source.
LK3	Configures the AD7871 14/8/CLK input for the appropriate serial or parallel interface.
LK4	Connects the AD7871 RD input directly to the two parallel connectors or to a decoded STRB and R/W input.
LK5	Connects the R3 pull-up resistor to SSTRB.
LK6	Connects the R4 pull-up resistor to SCLK.
LK7	Connects the R5 pull-up resistor to SDATA.

Remove LK5 to LK7 for parallel interfacing.

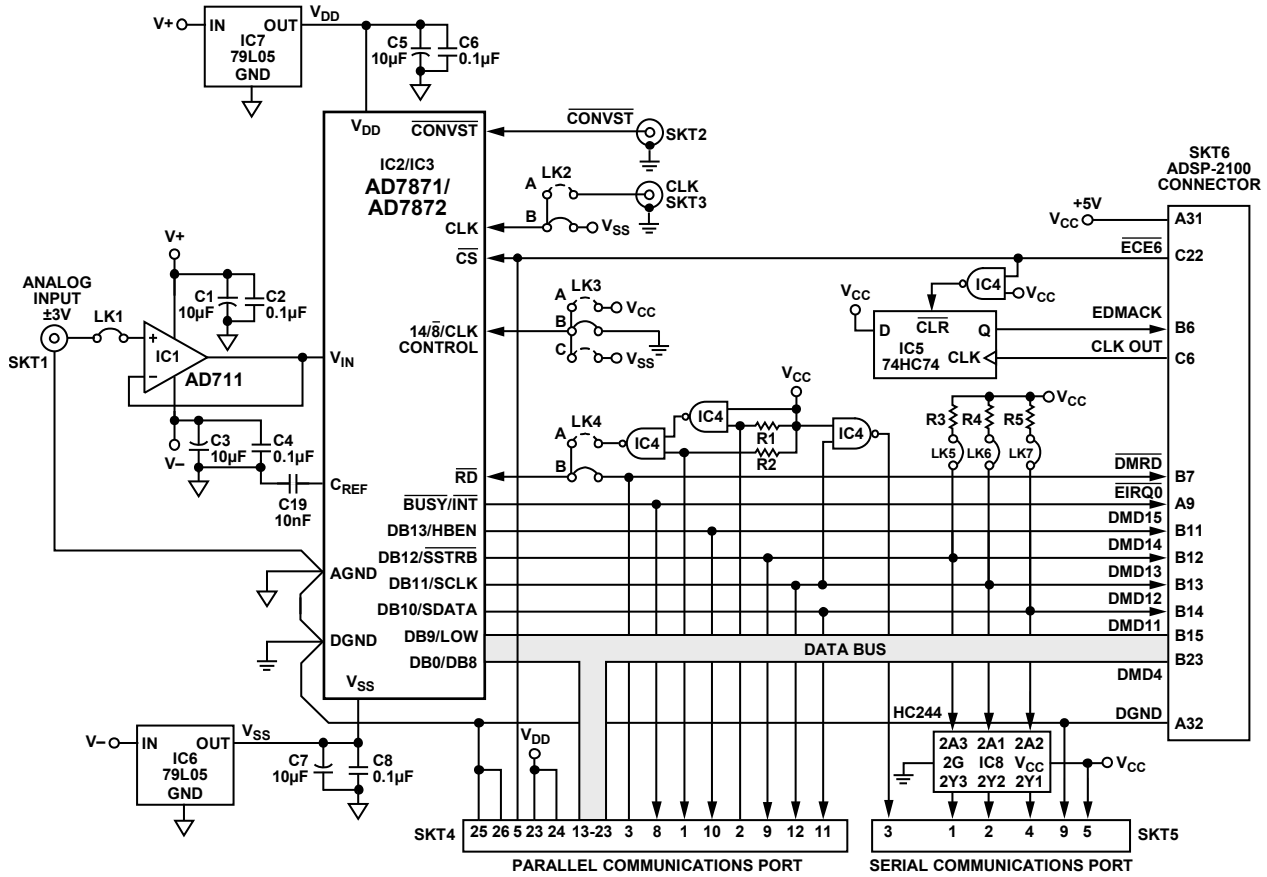

Figure 31. Data Acquisition Circuit Using the AD7871/AD7872

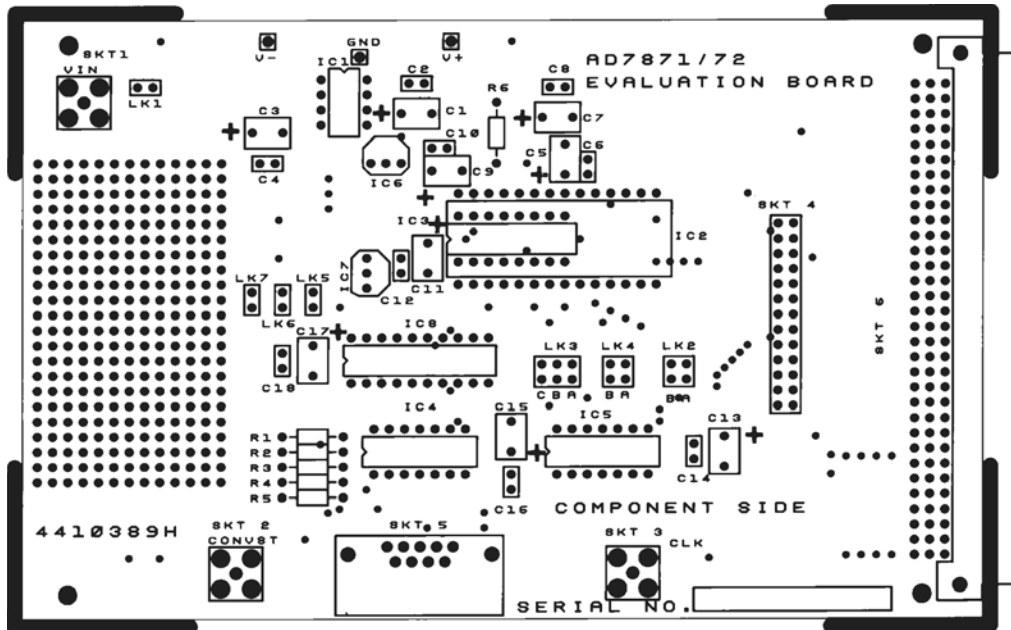
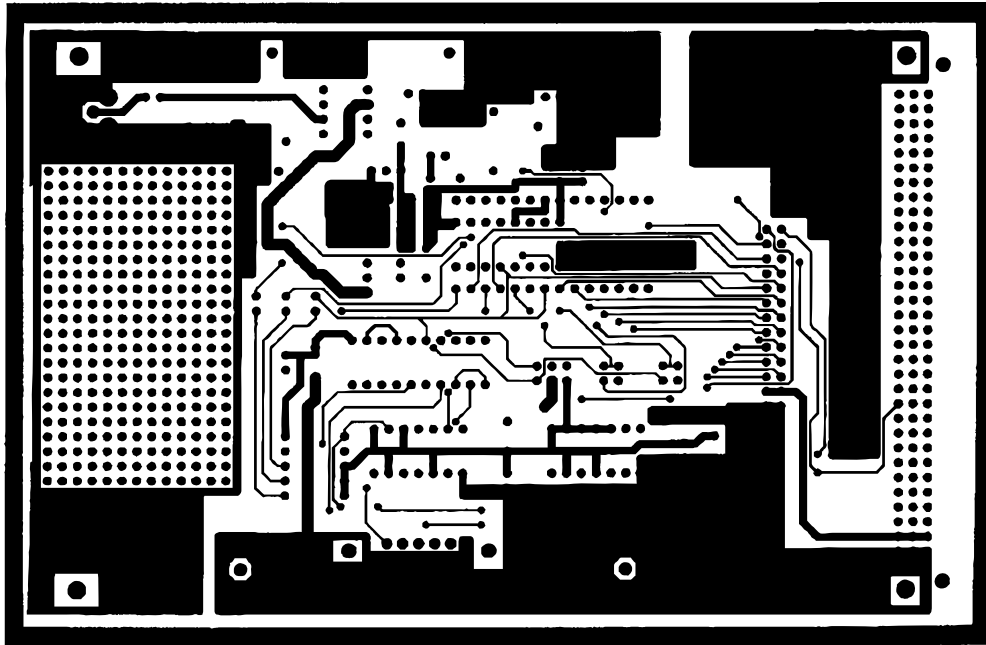
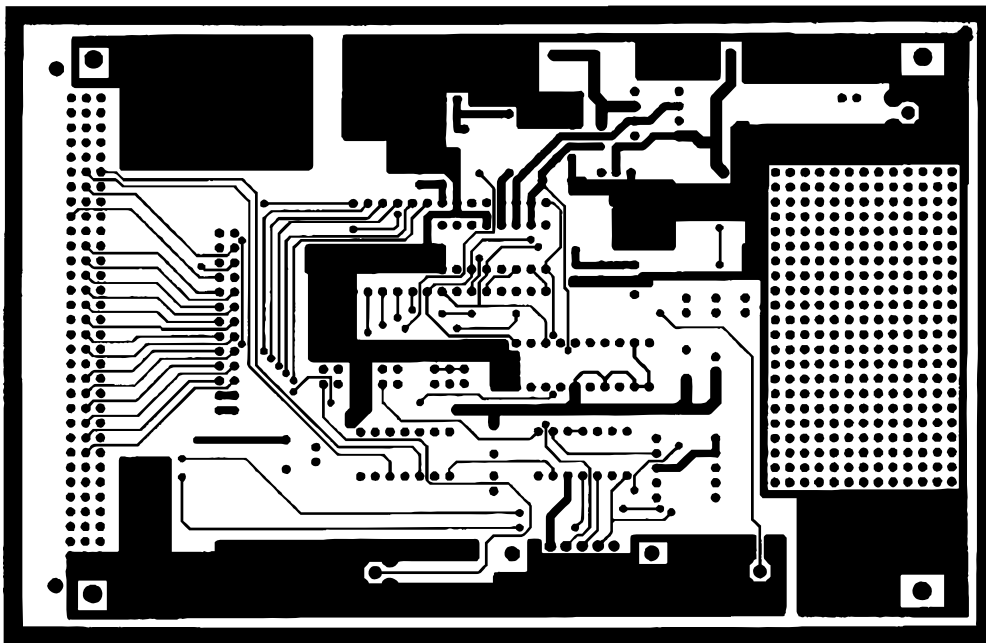

Figure 32. PCB Silkscreen for Figure 31



12889-031

Figure 33. PCB Component Side Layout for Figure 31



12889-032

Figure 34. PCB Solder Side Layout for Figure 31

OUTLINE DIMENSIONS

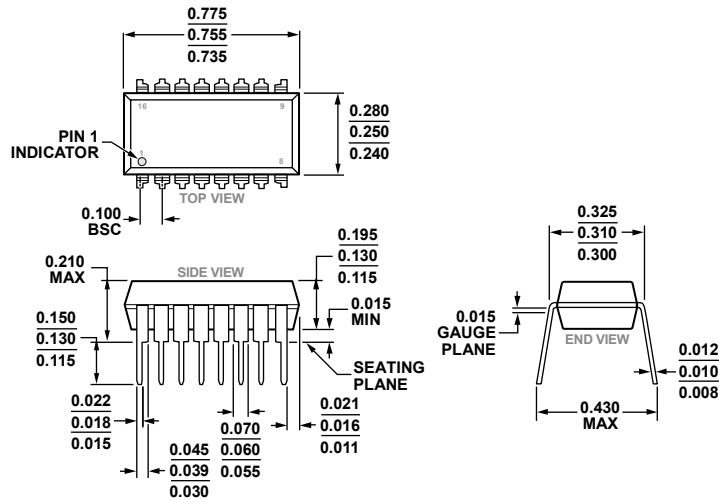

COMPLIANT TO JEDEC STANDARDS MS-001-BB

Figure 35. 16-Lead Plastic Dual In-Line Package [PDIP]  
Narrow Body  
(N-16)

Dimensions shown in inches

03-07-2014-D

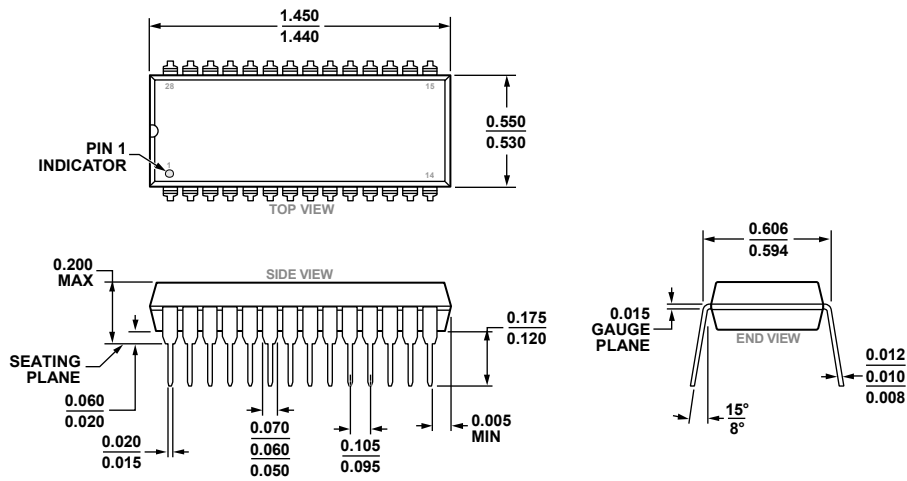

COMPLIANT TO JEDEC STANDARDS MS-011

Figure 36. 28-Lead Plastic Dual In-Line Package [PDIP]  
Wide Body  
(N-28-3)

Dimensions shown in inches

01-13-2015-A

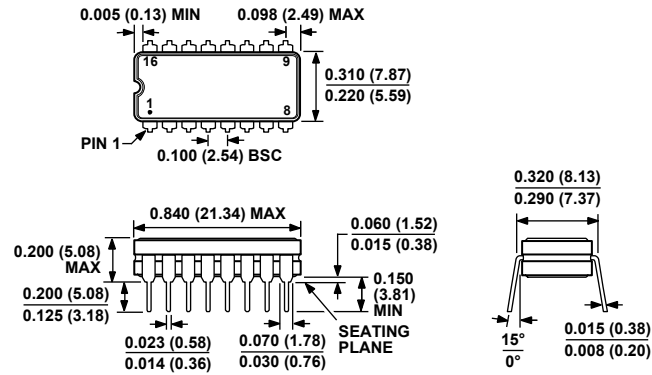

CONTROLLING DIMENSIONS ARE IN INCHES; MILLIMETER DIMENSIONS (IN PARENTHESES) ARE ROUNDED-OFF INCH EQUIVALENTS FOR REFERENCE ONLY AND ARE NOT APPROPRIATE FOR USE IN DESIGN.

Figure 37. 16-Lead Ceramic Dual In-Line Package [CERDIP] (Q-16)

Dimensions shown in inches and (millimeters)

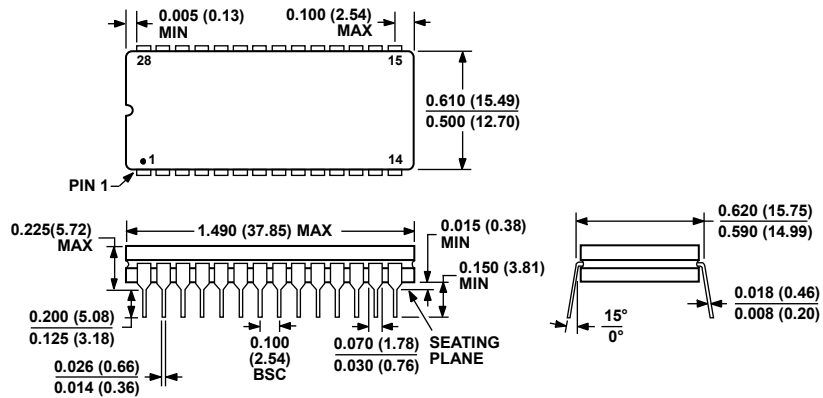

CONTROLLING DIMENSIONS ARE IN INCHES; MILLIMETER DIMENSIONS (IN PARENTHESES) ARE ROUNDED-OFF INCH EQUIVALENTS FOR REFERENCE ONLY AND ARE NOT APPROPRIATE FOR USE IN DESIGN.

Figure 38. 28-Lead Ceramic Dual In-Line Package [CERDIP] (Q-28-2)

Dimensions shown in inches and (millimeters)

030106-A

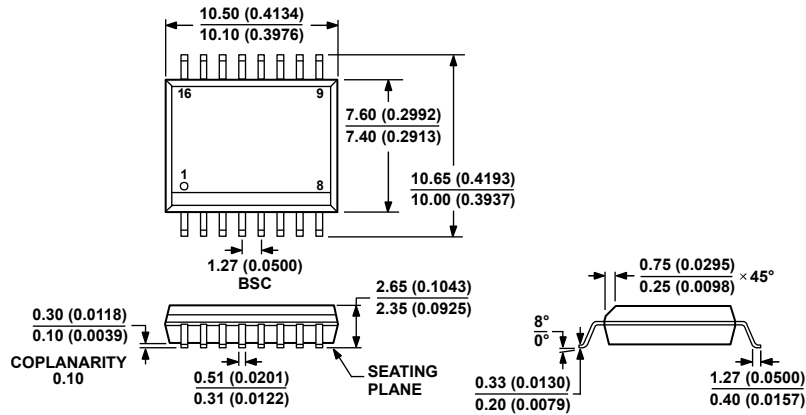

COMPLIANT TO JEDEC STANDARDS MS-013-AA  
 CONTROLLING DIMENSIONS ARE IN MILLIMETERS; INCH DIMENSIONS  
 (IN PARENTHESES) ARE ROUNDED-OFF MILLIMETER EQUIVALENTS FOR  
 REFERENCE ONLY AND ARE NOT APPROPRIATE FOR USE IN DESIGN.

06-27-2007-B

Figure 39. 16-Lead Standard Small Outline Package [SOIC\_W]  
 Wide Body  
 (RW-16)

Dimensions shown in millimeters and (inches)

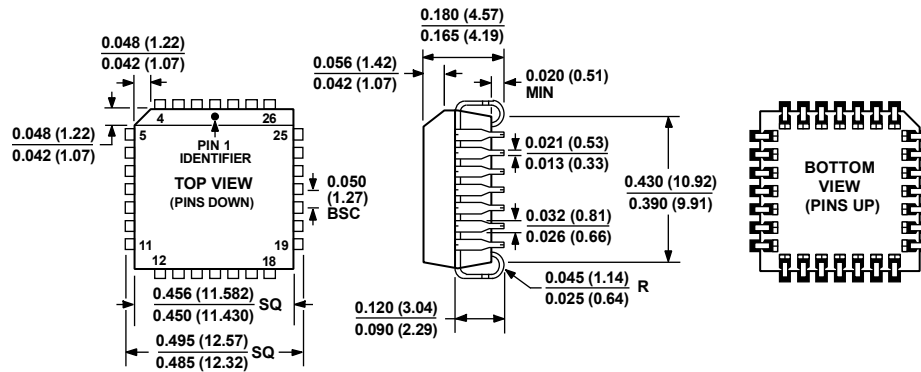

COMPLIANT TO JEDEC STANDARDS MO-047-AB  
 CONTROLLING DIMENSIONS ARE IN INCHES; MILLIMETER DIMENSIONS  
 (IN PARENTHESES) ARE ROUNDED-OFF INCH EQUIVALENTS FOR  
 REFERENCE ONLY AND ARE NOT APPROPRIATE FOR USE IN DESIGN.

042506-A

Figure 40. 28-Lead Plastic Leaded Chip Carrier [PLCC]  
 (P-28)

Dimensions shown in inches and (millimeters)

## ORDERING GUIDE

Model <sup>1,2,3,4</sup>	Temperature Range	Package Description	Package Option
AD7871JNZ	0°C to +70°C	28-Lead PDIP	N-28-3
AD7871JPZ	0°C to +70°C	28-Lead PLCC	P-28
AD7871JPZ-REEL	0°C to +70°C	28-Lead PLCC	P-28
AD7871KPZ	0°C to +70°C	28-Lead PLCC	P-28
AD7871TQ	-55°C to +125°C	28-Lead CERDIP	Q-28-2
AD7872ANZ	-40°C to +85°C	16-Lead PDIP	N-16
AD7872BRZ	-40°C to +85°C	16-Lead SOIC_W	RW-16
AD7872BRZ-REEL	-40°C to +85°C	16-Lead SOIC_W	RW-16
AD7872JNZ	0°C to +70°C	16-Lead PDIP	N-16
AD7872JRZ	0°C to +70°C	16-Lead SOIC_W	RW-16
AD7872JRZ-REEL	0°C to +70°C	16-Lead SOIC_W	RW-16
AD7872KNZ	0°C to +70°C	16-Lead PDIP	N-16
AD7872KRZ	0°C to +70°C	16-Lead SOIC_W	RW-16
AD7872KRZ-REEL	0°C to +70°C	16-Lead SOIC_W	RW-16
AD7872TQ	-55°C to +125°C	16-Lead CERDIP	Q-16

<sup>1</sup> Z = RoHS Compliant Part.

<sup>2</sup> To order MIL-STD-883, Class B, processed parts, add /883B to part number. Contact local sales office for military data sheet.

<sup>3</sup> Contact local sales office for LCCC availability.

<sup>4</sup> The AD787xTQ models are available to /883B processing only.

## Looking for pricing, stock, or lifecycle information?

Click below to explore more details on WIN SOURCE:

 [View AD7872BRZ on WIN SOURCE](#)

 [Analog Devices Inc. Information](#)

## Optimize Your Supply Chain with WIN SOURCE Solutions

-  Global Sourcing Solution
-  Obsolete Management
-  Cost Control Management
-  Shortage Management
-  Alternative Solution
-  Excess Inventory Management