



**THE DATASHEET OF
AD7983BCPZ-RL7**



FEATURES

- 16-bit resolution with no missing codes**
- Throughput: 1.33 MSPS**
- Low power dissipation: 10.5 mW typical @ 1.33 MSPS**
- INL: ±0.6 LSB typical, ±1.0 LSB maximum**
- SINAD: 91.6 dB @ 10 kHz**
- THD: -115 dB @ 10 kHz**
- Pseudo differential analog input range**
 - 0 V to V_{REF} with V_{REF} between 2.9 V to 5.5 V**
 - Any input range and easy to drive with the ADA4841**
- No pipeline delay**
- Single-supply 2.5 V operation with 1.8 V/2.5 V/3 V/5 V logic interface**
- Proprietary serial interface SPI-/QSPI™-/MICROWIRE™-/DSP-compatible¹**
- Daisy-chain multiple ADCs and busy indicator**
- 10-lead MSOP (MSOP-8 size) and 10-lead 3 mm × 3 mm QFN (LFCSP), SOT-23 size**
- Wide operating temperature range: -40°C to +85°C**

APPLICATIONS

- Battery-powered equipment**
- Communications**
- ATE**
- Data acquisitions**
- Medical instruments**

APPLICATION DIAGRAM

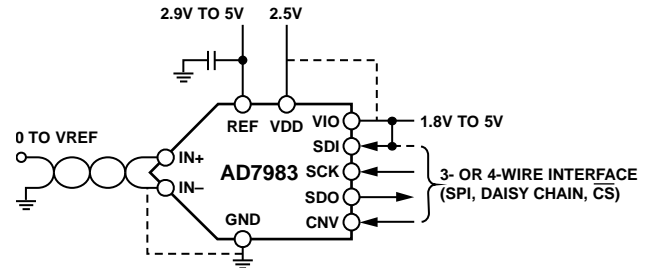

Figure 1.

GENERAL DESCRIPTION

The **AD7983** is a 16-bit, successive approximation, analog-to-digital converter (ADC) that operates from a single power supply, VDD. It contains a low power, high speed, 16-bit sampling ADC and a versatile serial interface port. On the CNV rising edge, it samples an analog input IN+ between 0 V to REF with respect to a ground sense IN-. The reference voltage, REF, is applied externally and can be set independent of the supply voltage, VDD. Its power scales linearly with throughput.

The SPI-compatible serial interface also features the ability, using the SDI input, to daisy-chain several ADCs on a single, 3-wire bus and provides an optional busy indicator. It is compatible with 1.8 V, 2.5 V, 3 V, or 5 V logic, using the separate supply VIO.

The **AD7983** is housed in a 10-lead MSOP or a 10-lead QFN (LFCSP) with operation specified from -40°C to +85°C.

¹ Protected by U.S. Patent 6,703,961.

Table 1. MSOP, QFN (LFCSP) 14-/16-/18-Bit PulSAR® ADC

Type	100 kSPS	250 kSPS	400 kSPS to 500 kSPS	≥1000 kSPS	ADC Driver
14-Bit	AD7940	AD7942 ¹	AD7946 ¹		
16-Bit	AD7680	AD7685 ¹	AD7686 ¹	AD7980 ¹	ADA4941
	AD7683	AD7687 ¹	AD7688 ¹	AD7983 ¹	ADA4841
	AD7684	AD7694	AD7693 ¹		
	AD7988-1		AD7988-5		
18-Bit	AD7989-1	AD7691 ¹	AD7690 ¹	AD7982 ¹	ADA4941
			AD7989-5	AD7984 ¹	ADA4841

¹ Pin-for-pin compatible.

Rev. B

Document Feedback

Information furnished by Analog Devices is believed to be accurate and reliable. However, no responsibility is assumed by Analog Devices for its use, nor for any infringements of patents or other rights of third parties that may result from its use. Specifications subject to change without notice. No license is granted by implication or otherwise under any patent or patent rights of Analog Devices. Trademarks and registered trademarks are the property of their respective owners.

TABLE OF CONTENTS

Features	1	Driver Amplifier Choice	14
Applications.....	1	Voltage Reference Input	15
Application Diagram	1	Power Supply.....	15
General Description	1	Digital Interface	16
Revision History	2	$\overline{\text{CS}}$ MODE, 3-Wire Without Busy Indicator	17
Specifications.....	3	$\overline{\text{CS}}$ Mode, 3-Wire with Busy Indicator	18
Timing Specifications.....	5	$\overline{\text{CS}}$ Mode, 4-Wire Without Busy Indicator	19
Absolute Maximum Ratings.....	6	$\overline{\text{CS}}$ Mode, 4-Wire with Busy Indicator	20
ESD Caution.....	6	Chain Mode Without Busy Indicator	21
Pin Configurations and Function Descriptions	7	Chain Mode with Busy Indicator	22
Typical Performance Characteristics	8	Application Hints	23
Terminology	11	Layout	23
Theory of Operation	12	Evaluating the Performance of the AD7983	23
Circuit Information.....	12	Outline Dimensions	24
Converter Operation.....	12	Ordering Guide	24
Typical Connection Diagram.....	13		
Analog Inputs.....	14		

REVISION HISTORY

7/14—Rev. A to Rev. B

Added Patent Endnote and Changes to Table 1	1
Changed Standby Current from 0.35 nA to 1.1 mA	4
Added EPAD Note.....	7
Changes to Figure 21	12
Changes to Power Supply Section	15
Changes to Evaluating the Performance of the AD7983 Section	23
Updated Outline Dimensions	24
Changes to Ordering Guide	24

3/10—Rev. 0 to Rev. A

Deleted Endnote 1 from Features Section, General Description Section, and Table 1.....	1
Changes to Table 5.....	6
Deleted Endnote 1 from Figure 5 Caption.....	7
Changes to Figure 21	12
Deleted Endnote 1 from Circuit Information Section.....	12
Changes to Figure 41 Caption.....	24
Changes to Ordering Guide	24

11/07—Revision 0: Initial Version

SPECIFICATIONS

VDD = 2.5 V, VIO = 2.3 V to 5.5 V, REF = 5 V, TA = -40°C to +85°C, unless otherwise noted.

Table 2.

Parameter	Conditions	Min	Typ	Max	Unit
RESOLUTION		16			Bits
ANALOG INPUT					
Voltage Range	IN+ – IN–	0		V _{REF}	V
Absolute Input Voltage	IN+	-0.1		V _{REF} + 0.1	V
	IN–	-0.1		+0.1	V
Analog Input CMRR	f _{IN} = 100 kHz		60		dB ¹
Leakage Current @ 25°C	Acquisition phase		1		nA
Input Impedance		See the Analog Inputs section			
ACCURACY					
No Missing Codes		16			Bits
Differential Linearity Error		-0.9	±0.4	+0.9	LSB ²
Integral Linearity Error		-1.0	±0.6	+1.0	LSB ²
Transition Noise			0.52		LSB ²
Gain Error, T _{MIN} to T _{MAX} ³			±2		LSB ²
Gain Error Temperature Drift			±0.41		ppm/°C
Zero Error, T _{MIN} to T _{MAX} ³		-0.9	±0.44	+0.9	mV
Zero Temperature Drift			0.54		ppm/°C
Power Supply Sensitivity	VDD = 2.5 V ± 5%		±0.1		LSB ²
THROUGHPUT					
Conversion Rate		0		1.33	MSPS
Transient Response	Full-scale step			290	ns
AC ACCURACY					
Dynamic Range			93		dB ¹
Signal-to-Noise Ratio, SNR	f _{IN} = 1 kHz	90.5	92		dB ¹
Spurious-Free Dynamic Range, SFDR	f _{IN} = 10 kHz		114		dB ¹
Total Harmonic Distortion, THD	f _{IN} = 10 kHz		-115		dB ¹
Signal-to-(Noise + Distortion), SINAD	f _{IN} = 10 kHz		91.6		dB ¹

¹ All specifications in dB are referred to a full-scale input FSR. Tested with an input signal at 0.5 dB below full scale, unless otherwise specified.

² LSB means least significant bit. With the 5 V input range, 1 LSB is 76.3 μV.

³ See the Terminology section. These specifications include full temperature range variation, but not the error contribution from the external reference.

VDD = 2.5 V, VIO = 2.3 V to 5.5 V, REF = 5 V, TA = -40°C to +85°C, unless otherwise noted.

Table 3.

Parameter	Conditions	Min	Typ	Max	Unit
REFERENCE					
Voltage Range		2.9		5.1	V
Load Current	1.33 MSPS		500		μA
SAMPLING DYNAMICS					
-3 dB Input Bandwidth			10		MHz
Aperture Delay			2.0		ns
DIGITAL INPUTS					
Logic Levels					
V _{IL}	VIO > 3V	-0.3		0.3 × VIO	V
V _{IH}	VIO > 3V	0.7 × VIO		VIO + 0.3	V
V _{IL}	VIO ≤ 3V	-0.3		0.1 × VIO	V
V _{IH}	VIO ≤ 3V	0.9 × VIO		VIO + 0.3	V
I _{IL}		-1		+1	μA
I _{IH}		-1		+1	μA
DIGITAL OUTPUTS					
Data Format		Serial 16 bits straight binary			
Pipeline Delay		Conversion results available immediately after completed conversion			
V _{OL}	I _{SINK} = 500 μA			0.4	V
V _{OH}	I _{SOURCE} = -500 μA	VIO - 0.3			V
POWER SUPPLIES					
VDD		2.375	2.5	2.625	V
VIO	Specified performance	2.3		5.5	V
VIO Range		1.8		5.5	V
Standby Current ^{1,2}	VDD and VIO = 2.5 V		1.1		mA
Power Dissipation	1.33 MSPS throughput		10.5	12	mW
Energy per Conversion			7.9		nJ/sample
TEMPERATURE RANGE ³					
Specified Performance	T _{MIN} to T _{MAX}	-40		+85	°C

¹ With all digital inputs forced to VIO or GND as required.

² During the acquisition phase.

³ Contact sales for extended temperature range.

TIMING SPECIFICATIONS

$T_A = -40^{\circ}\text{C}$ to $+85^{\circ}\text{C}$, $V_{DD} = 2.37\text{ V}$ to 2.63 V , $V_{IO} = 3.3\text{ V}$ to 5.5 V , unless otherwise noted. See Figure 2 and Figure 3 for load conditions.

Table 4.

Parameter	Symbol	Min	Typ	Max	Unit
Conversion Time: CNV Rising Edge to Data Available	t_{CONV}	300		500	ns
Acquisition Time	t_{ACQ}	250			ns
Time Between Conversions	t_{CYC}	750			ns
CNV Pulse Width (\overline{CS} Mode)	t_{CNVH}	10			ns
SCK Period (\overline{CS} Mode)	t_{SCK}				
VIO Above 4.5 V		10.5			ns
VIO Above 3 V		12			ns
VIO Above 2.7 V		13			ns
VIO Above 2.3 V		15			ns
SCK Period (Chain Mode)	t_{SCK}				
VIO Above 4.5 V		11.5			ns
VIO Above 3 V		13			ns
VIO Above 2.7 V		14			ns
VIO Above 2.3 V		16			ns
SCK Low Time	t_{SCKL}	4.5			ns
SCK High Time	t_{SCKH}	4.5			ns
SCK Falling Edge to Data Remains Valid	t_{HSDO}	3			ns
SCK Falling Edge to Data Valid Delay	t_{DSDO}				
VIO Above 4.5 V				9.5	ns
VIO Above 3 V				11	ns
VIO Above 2.7 V				12	ns
VIO Above 2.3 V				14	ns
CNV or SDI Low to SDO D15 MSB Valid (\overline{CS} Mode)	t_{EN}				
VIO Above 3 V				10	ns
VIO Above 2.3 V				15	ns
CNV or SDI High or Last SCK Falling Edge to SDO High Impedance (\overline{CS} Mode)	t_{DIS}			20	ns
SDI Valid Setup Time from CNV Rising Edge	$t_{SSDICNV}$	5			ns
SDI Valid Hold Time from CNV Rising Edge (\overline{CS} Mode)	$t_{HSDICNV}$	2			ns
SDI Valid Hold Time from CNV Rising Edge (Chain Mode)	$t_{HSDICNV}$	0			ns
SCK Valid Setup Time from CNV Rising Edge (Chain Mode)	$t_{SSCKCNV}$	5			ns
SCK Valid Hold Time from CNV Rising Edge (Chain Mode)	$t_{HSCKCNV}$	5			ns
SDI Valid Setup Time from SCK Falling Edge (Chain Mode)	$t_{SSDISCK}$	2			ns
SDI Valid Hold Time from SCK Falling Edge (Chain Mode)	$t_{HSDISCK}$	3			ns
SDI High to SDO High (Chain Mode with Busy Indicator)	$t_{DSDOSDI}$			15	ns

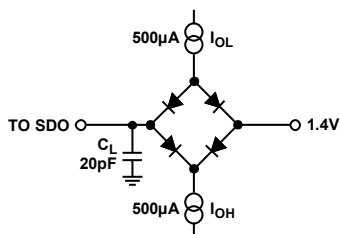
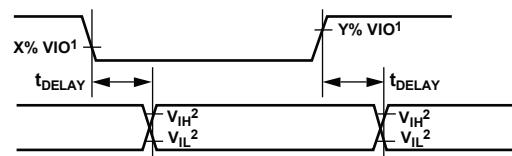

Figure 2. Load Circuit for Digital Interface Timing



1FOR $V_{IO} \leq 3.0\text{V}$, $X = 90$ AND $Y = 10$; FOR $V_{IO} > 3.0\text{V}$ $X = 70$, AND $Y = 30$.
 2MINIMUM V_{IH} AND MAXIMUM V_{IL} USED. SEE DIGITAL INPUTS SPECIFICATIONS IN TABLE 3.

Figure 3. Voltage Levels for Timing

ABSOLUTE MAXIMUM RATINGS

Table 5.

Parameter	Rating
Analog Inputs	
IN+, ¹ IN- ¹ to GND	-0.3 V to V _{REF} + 0.3 V or ±130 mA
Supply Voltage	
REF, VIO to GND	-0.3 V to +6 V
VDD to GND	-0.3 V to +3 V
VDD to VIO	+3 V to -6 V
Digital Inputs to GND	-0.3 V to VIO + 0.3 V
Digital Outputs to GND	-0.3 V to VIO + 0.3 V
Storage Temperature Range	-65°C to +150°C
Junction Temperature	150°C
θ _{JA} Thermal Impedance	
10-Lead MSOP	200°C/W
10-Lead QFN (LFCSP)	48.7°C/W
θ _{JC} Thermal Impedance	
10-Lead MSOP	44°C/W
10-Lead QFN (LFCSP)	2.96°C/W
Lead Temperature	
Vapor Phase (60 sec)	215°C
Infrared (15 sec)	220°C

¹ See the Analog Inputs section.

Stresses above those listed under Absolute Maximum Ratings may cause permanent damage to the device. This is a stress rating only; functional operation of the device at these or any other conditions above those indicated in the operational section of this specification is not implied. Exposure to absolute maximum rating conditions for extended periods may affect device reliability.

ESD CAUTION



ESD (electrostatic discharge) sensitive device. Charged devices and circuit boards can discharge without detection. Although this product features patented or proprietary protection circuitry, damage may occur on devices subjected to high energy ESD. Therefore, proper ESD precautions should be taken to avoid performance degradation or loss of functionality.

PIN CONFIGURATIONS AND FUNCTION DESCRIPTIONS

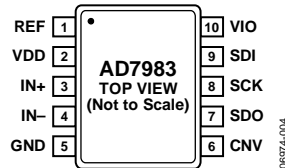
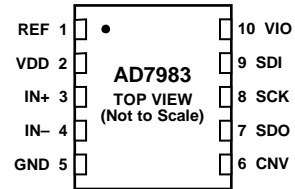

Figure 4. 10-Lead MSOP Pin Configuration



NOTES
1. EXPOSED PAD. CONNECT THE EXPOSED PAD TO GND. THIS CONNECTION IS NOT REQUIRED TO MEET THE ELECTRICAL PERFORMANCES.

Figure 5. 10-Lead LFCSP Pin Configuration

Table 6. Pin Function Descriptions

Pin No.	Mnemonic	Type ¹	Description
1	REF	AI	Reference Input Voltage. The REF range is from 2.9 V to 5.1 V. It is referred to the GND pin. This pin should be decoupled closely to the pin with a 10 μ F capacitor.
2	VDD	P	Power Supply.
3	IN+	AI	Analog Input. It is referred to IN-. The voltage range, for example, the difference between IN+ and IN-, is 0 V to V_{REF} .
4	IN-	AI	Analog Input Ground Sense. To be connected to the analog ground plane or to a remote sense ground.
5	GND	P	Power Supply Ground.
6	CNV	DI	Convert Input. This input has multiple functions. On its rising edge, it initiates the conversions and selects the interface mode of the part: chain or \overline{CS} mode. In \overline{CS} mode, it enables the SDO pin when low. In chain mode, the data should be read when CNV is high.
7	SDO	DO	Serial Data Output. The conversion result is output on this pin. It is synchronized to SCK.
8	SCK	DI	Serial Data Clock Input. When the part is selected, the conversion result is shifted out by this clock.
9	SDI	DI	Serial Data Input. This input provides multiple features. It selects the interface mode of the ADC as follows: Chain mode is selected if SDI is low during the CNV rising edge. In this mode, SDI is used as a data input to daisy-chain the conversion results of two or more ADCs onto a single SDO line. The digital data level on SDI is output on SDO with a delay of 16 SCK cycles. \overline{CS} mode is selected if SDI is high during the CNV rising edge. In this mode, either SDI or CNV can enable the serial output signals when low; if SDI or CNV is low when the conversion is complete, the busy indicator feature is enabled.
10	VIO	P	Input/Output Interface Digital Power. Nominally at the same supply as the host interface (1.8 V, 2.5 V, 3 V, or 5 V).
	EPAD		Exposed Pad. For the 10-lead LFCSP only, connect the exposed pad to GND. This connection is not required to meet the electrical performances.

¹ AI = analog input, DI = digital input, DO = digital output, and P = power.

TYPICAL PERFORMANCE CHARACTERISTICS

VDD = 2.5 V, REF = 5 V, VIO = 3.3 V, unless otherwise noted.

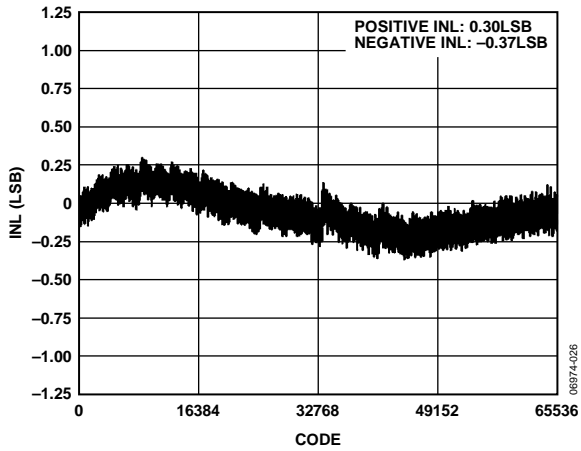

Figure 6. Integral Nonlinearity vs. Code

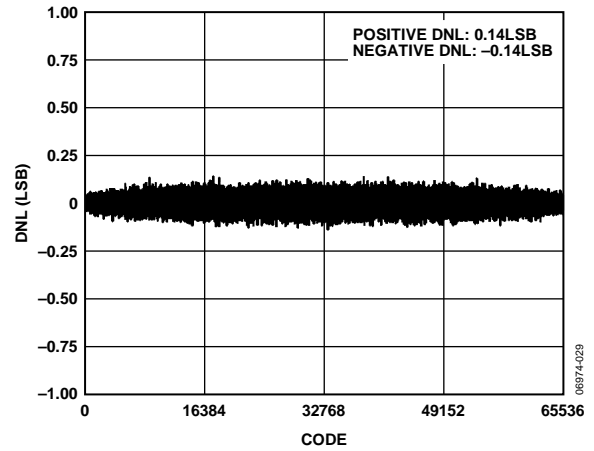

Figure 9. Differential Nonlinearity vs. Code

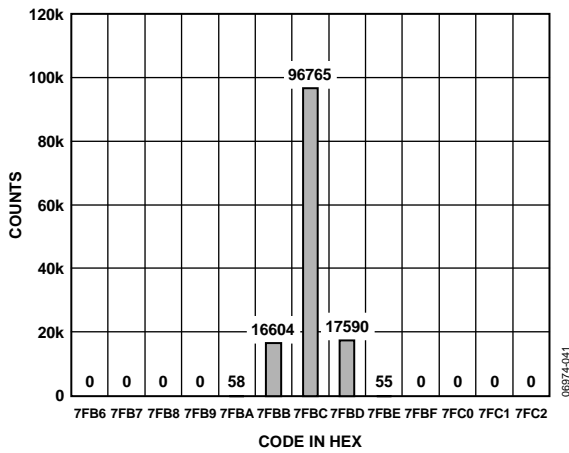

Figure 7. Histogram of a DC Input at the Code Center

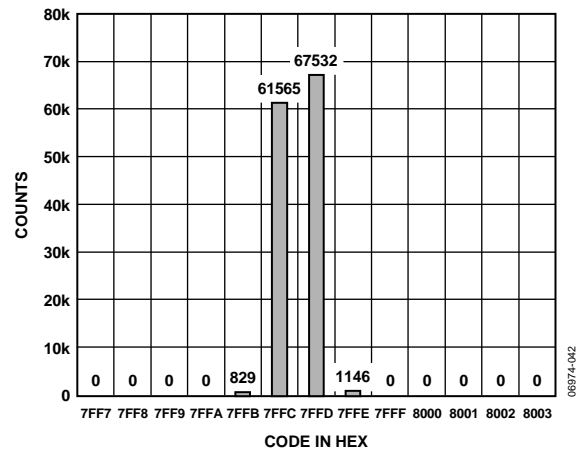

Figure 10. Histogram of a DC Input at the Code Transition

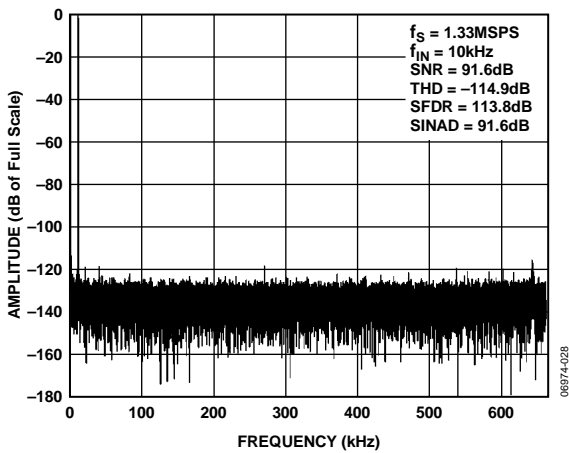

Figure 8. FFT Plot

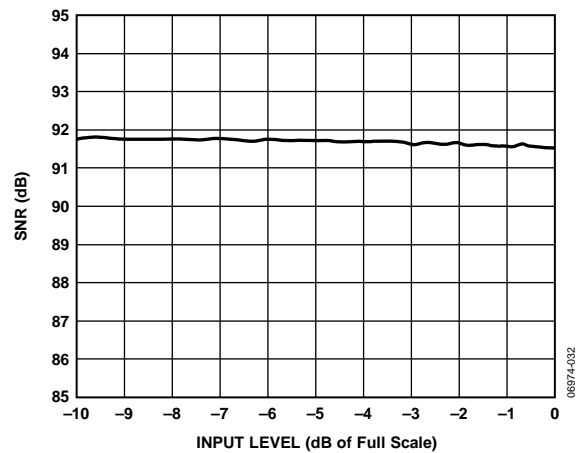

Figure 11. SNR vs. Input Level

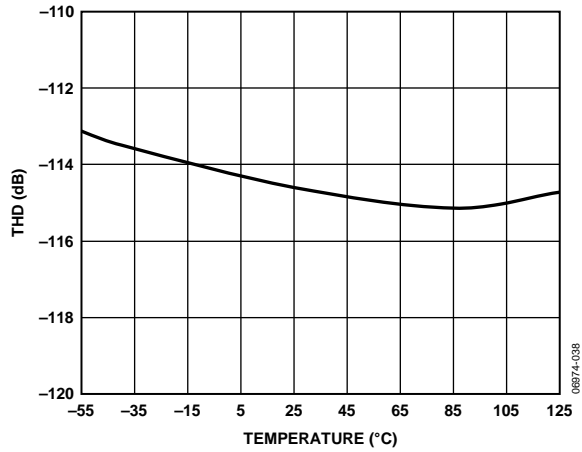

Figure 12. THD vs. Temperature

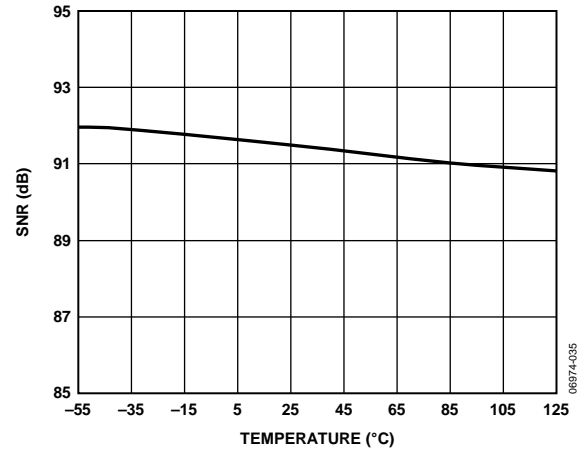

Figure 15. SNR vs. Temperature

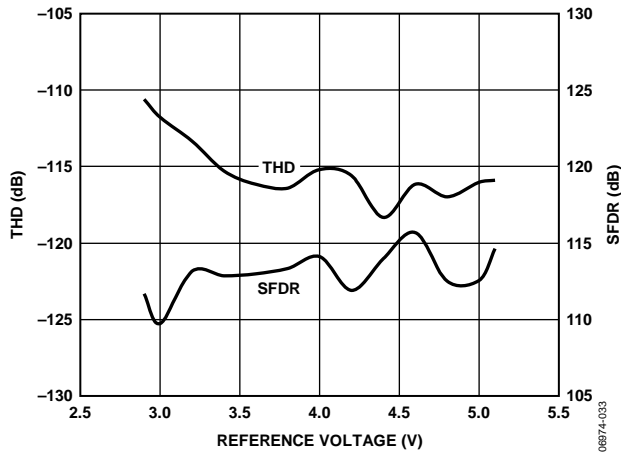

Figure 13. THD, SFDR vs. Reference Voltage

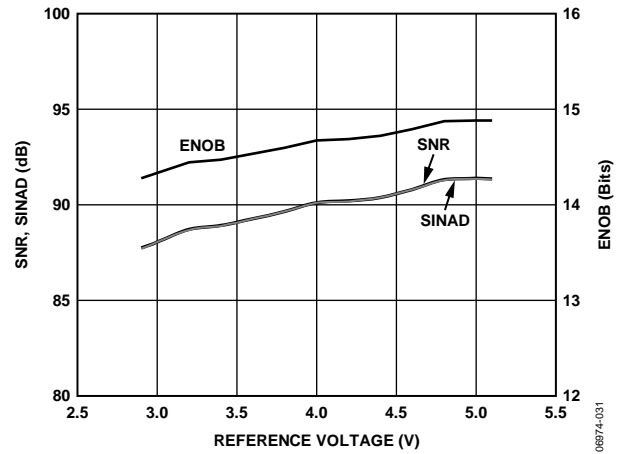

Figure 16. SNR, SINAD, and ENOB vs. Reference Voltage

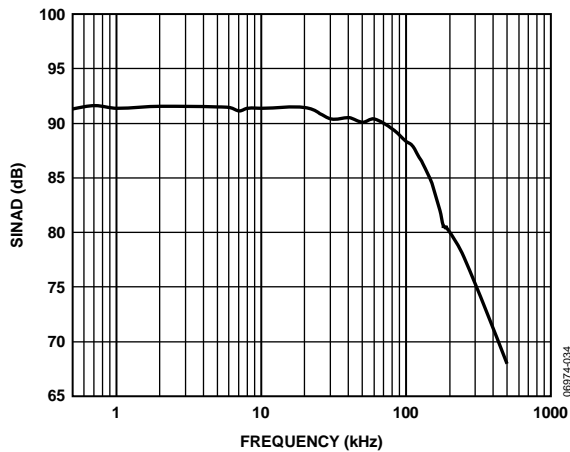

Figure 14. SINAD vs. Frequency

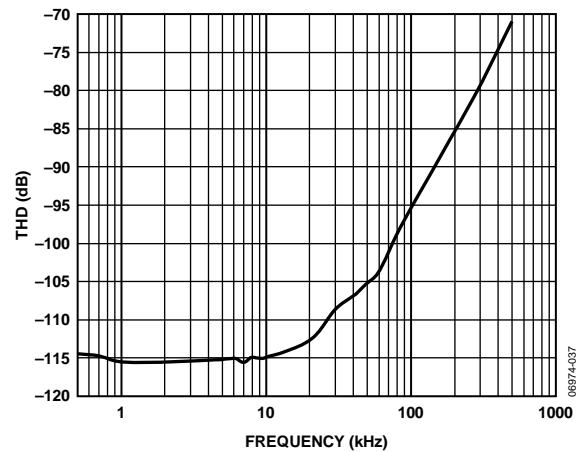

Figure 17. THD vs. Frequency

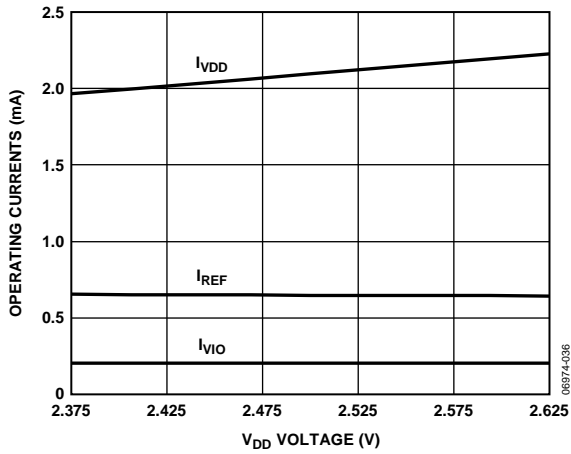

Figure 18. Operating Currents vs. Supply

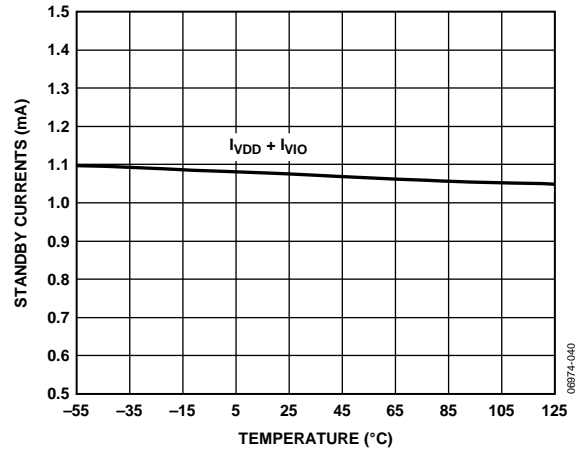

Figure 20. Standby Currents vs. Temperature

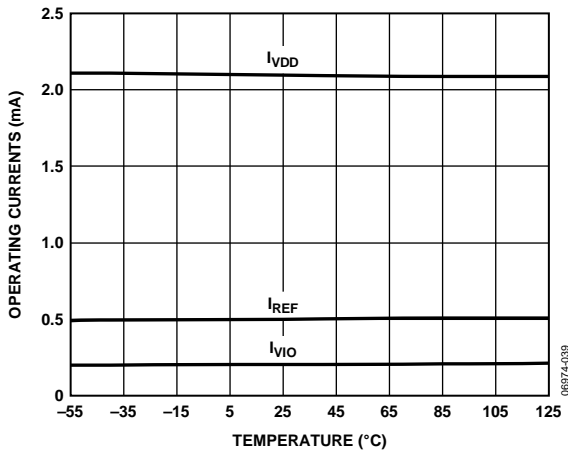

Figure 19. Operating Currents vs. Temperature

TERMINOLOGY

Integral Nonlinearity Error (INL)

INL refers to the deviation of each individual code from a line drawn from negative full scale through positive full scale. The point used as negative full scale occurs $\frac{1}{2}$ LSB before the first code transition. Positive full scale is defined as a level $1\frac{1}{2}$ LSB beyond the last code transition. The deviation is measured from the middle of each code to the true straight line (see Figure 22).

Differential Nonlinearity Error (DNL)

In an ideal ADC, code transitions are 1 LSB apart. DNL is the maximum deviation from this ideal value. It is often specified in terms of resolution for which no missing codes are guaranteed.

Offset Error

The first transition should occur at a level $\frac{1}{2}$ LSB above analog ground (38.1 μ V for the 0 V to 5 V range). The offset error is the deviation of the actual transition from that point.

Gain Error

The last transition (from 111 ... 10 to 111 ... 11) should occur for an analog voltage $1\frac{1}{2}$ LSB below the nominal full scale (4.999886 V for the 0 V to 5 V range). The gain error is the deviation of the actual level of the last transition from the ideal level after the offset is adjusted out.

Spurious-Free Dynamic Range (SFDR)

SFDR is the difference, in decibels (dB), between the rms amplitude of the input signal and the peak spurious signal.

Effective Number of Bits (ENOB)

ENOB is a measurement of the resolution with a sine wave input. It is related to SINAD as follows:

$$ENOB = (SINAD_{dB} - 1.76)/6.02$$

and is expressed in bits.

Noise-Free Code Resolution

Noise-free code resolution is the number of bits beyond which it is impossible to distinctly resolve individual codes. It is calculated as

$$Noise\text{-Free Code Resolution} = \log_2(2^N/Peak\text{-to-Peak Noise})$$

and is expressed in bits.

Effective Resolution

Effective resolution is calculated as

$$Effective\ Resolution = \log_2(2^N/RMS\ Input\ Noise)$$

and is expressed in bits.

Total Harmonic Distortion (THD)

THD is the ratio of the rms sum of the first five harmonic components to the rms value of a full-scale input signal and is expressed in dB.

Dynamic Range

Dynamic range is the ratio of the rms value of the full scale to the total rms noise measured with the inputs shorted together. The value for dynamic range is expressed in dB. It is measured with a signal at -60 dBFS to include all noise sources and DNL artifacts.

Signal-to-Noise Ratio (SNR)

SNR is the ratio of the rms value of the actual input signal to the rms sum of all other spectral components below the Nyquist frequency, excluding harmonics and dc. The value for SNR is expressed in dB.

Signal-to-(Noise + Distortion) Ratio (SINAD)

SINAD is the ratio of the rms value of the actual input signal to the rms sum of all other spectral components below the Nyquist frequency, including harmonics but excluding dc. The value for SINAD is expressed in dB.

Aperture Delay

Aperture delay is the measurement of the acquisition performance. It is the time between the rising edge of the CNV input and when the input signal is held for a conversion.

Transient Response

Transient response is the time required for the ADC to accurately acquire its input after a full-scale step function is applied.

THEORY OF OPERATION

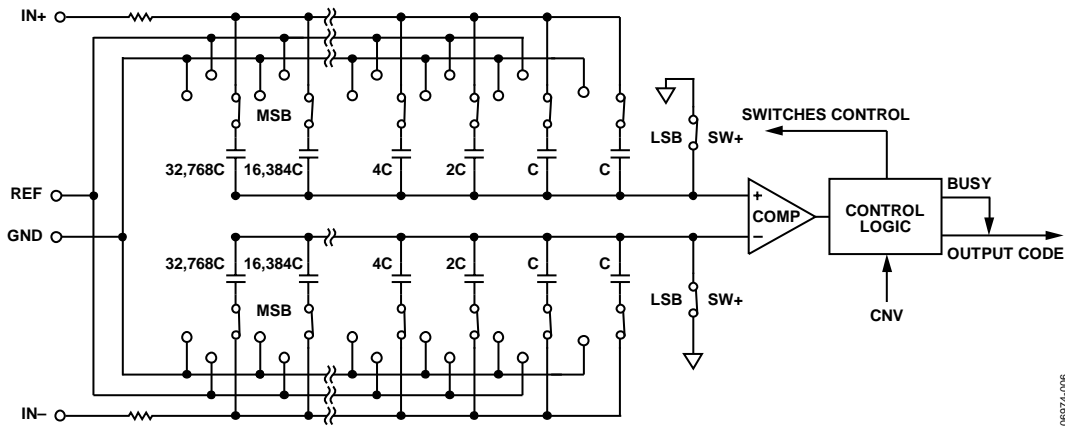

Figure 21. ADC Simplified Schematic

CIRCUIT INFORMATION

The [AD7983](#) is a fast, low power, single-supply, precise 16-bit ADC that uses a successive approximation architecture.

The [AD7983](#) is capable of converting 1,000,000 samples per second (1 MSPS) and powers down between conversions. When operating at 10 kSPS, for example, it consumes 70 μW typically, making it ideal for battery-powered applications.

The [AD7983](#) provides the user with an on-chip track-and-hold and does not exhibit any pipeline delay or latency, making it ideal for multiple multiplexed channel applications.

The [AD7983](#) can be interfaced to any 1.8 V to 5 V digital logic family. It is available in a 10-lead MSOP or a tiny 10-lead QFN (LFCSP) that allows space savings and flexible configurations.

It is pin-for-pin compatible with the 18-bit [AD7982](#).

CONVERTER OPERATION

The [AD7983](#) is a successive approximation ADC based on a charge redistribution DAC. Figure 21 shows the simplified schematic of the ADC. The capacitive DAC consists of two identical arrays of 16 binary weighted capacitors, which are connected to the two comparator inputs.

During the acquisition phase, terminals of the array tied to the input of the comparator are connected to GND via SW+ and SW-. All independent switches are connected to the analog inputs. Therefore, the capacitor arrays are used as sampling capacitors and acquire the analog signal on the IN+ and IN- inputs. When the acquisition phase is complete and the CNV input goes high, a conversion phase is initiated. When the conversion phase begins, SW+ and SW- are opened first. The two capacitor arrays are then disconnected from the inputs and connected to the GND input. Therefore, the differential voltage between the inputs IN+ and IN- captured at the end of the acquisition phase is applied to the comparator inputs, causing the comparator to become unbalanced. By switching each element of the capacitor array between GND and REF, the comparator input varies by binary weighted voltage steps ($V_{\text{REF}}/2, V_{\text{REF}}/4 \dots V_{\text{REF}}/65,536$). The control logic toggles these switches, starting with the MSB, to bring the comparator back into a balanced condition. After the completion of this process, the part returns to the acquisition phase and the control logic generates the ADC output code and a busy signal indicator.

Because the [AD7983](#) has an on-board conversion clock, the serial clock, SCK, is not required for the conversion process.

Transfer Functions

The ideal transfer characteristic for the AD7983 is shown in Figure 22 and Table 7.

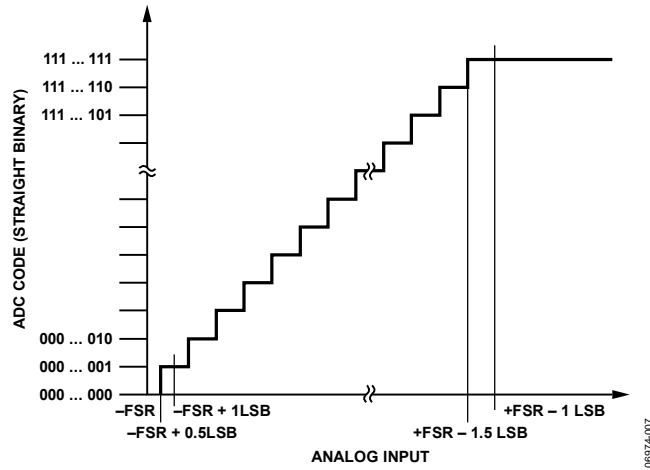

Figure 22. ADC Ideal Transfer Function

Table 7. Output Codes and Ideal Input Voltages

Description	Analog Input	
	V _{REF} = 5 V	Digital Output Code (Hex)
FSR - 1 LSB	4.999924 V	FFFF ¹
Midscale + 1 LSB	2.500076 V	8001
Midscale	2.5 V	8000
Midscale - 1 LSB	2.499924 V	7FFF
-FSR + 1 LSB	76.3 μV	0001
-FSR	0 V	0000 ²

¹This is also the code for an overranged analog input (V_{IN+} - V_{IN-} above V_{REF} - V_{GND}).
²This is also the code for an underranged analog input (V_{IN+} - V_{IN-} below V_{GND}).

TYPICAL CONNECTION DIAGRAM

Figure 23 shows an example of the recommended connection diagram for the AD7983 when multiple supplies are available.

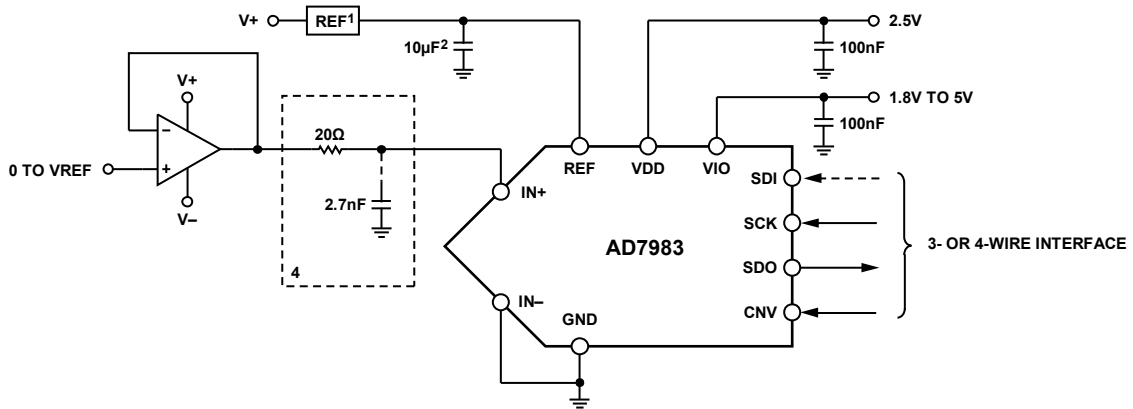

¹SEE THE VOLTAGE REFERENCE INPUT SECTION FOR REFERENCE SELECTION.
²C_{REF} IS USUALLY A 10μF CERAMIC CAPACITOR (X5R).
³SEE THE DRIVER AMPLIFIER CHOICE SECTION.
⁴OPTIONAL FILTER. SEE THE ANALOG INPUTS SECTION.
⁵SEE THE DIGITAL INTERFACE SECTION FOR THE MOST CONVENIENT INTERFACE MODE.

Figure 23. Typical Application Diagram with Multiple Supplies

ANALOG INPUTS

Figure 24 shows an equivalent circuit of the input structure of the AD7983.

The two diodes, D1 and D2, provide ESD protection for the analog inputs, IN+ and IN-. Care must be taken to ensure that the analog input signal never exceeds the supply rails by more than 0.3 V, because this causes these diodes to become forward-biased and start conducting current. These diodes can handle a forward-biased current of 130 mA maximum. For instance, these conditions could eventually occur when the supplies of the input buffer (U1) are different from VDD. In such a case (for example, an input buffer with a short circuit), the current limitation can be used to protect the part.

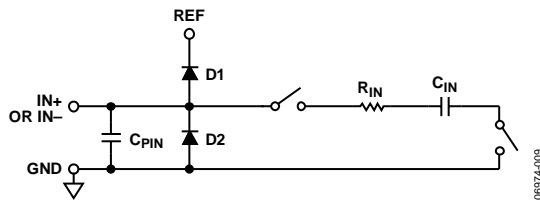

Figure 24. Equivalent Analog Input Circuit

The analog input structure allows the sampling of the true differential signal between IN+ and IN-. By using these differential inputs, signals common to both inputs are rejected.

During the acquisition phase, the impedance of the analog inputs (IN+ and IN-) can be modeled as a parallel combination of capacitor, C_{PIN} , and the network formed by the series connection of R_{IN} and C_{IN} . C_{PIN} is primarily the pin capacitance. R_{IN} is typically 400 Ω and is a lumped component made up of some serial resistors and the on resistance of the switches. C_{IN} is typically 30 pF and is mainly the ADC sampling capacitor. During the conversion phase, where the switches are opened, the input impedance is limited to C_{PIN} . R_{IN} and C_{IN} make a 1-pole, low-pass filter that reduces undesirable aliasing effects and limits the noise.

When the source impedance of the driving circuit is low, the AD7983 can be driven directly. Large source impedances significantly affect the ac performance, especially THD. The dc performances are less sensitive to the input impedance. The maximum source impedance depends on the amount of THD that can be tolerated. The THD degrades as a function of the source impedance and the maximum input frequency.

DRIVER AMPLIFIER CHOICE

Although the AD7983 is easy to drive, the driver amplifier needs to meet the following requirements:

- The noise generated by the driver amplifier needs to be kept as low as possible to preserve the SNR and transition noise performance of the AD7983. The noise coming from the driver is filtered by the AD7983 analog input circuit's 1-pole, low-pass filter made by R_{IN} and C_{IN} or by the external filter, if one is used. Because the typical noise of the AD7983 is 39.7 μV rms, the SNR degradation due to the amplifier is

$$SNR_{LOSS} = 20 \log \left(\frac{39.7}{\sqrt{39.7^2 + \frac{\pi}{2} f_{-3dB} (Ne_N)^2}} \right)$$

where:

f_{-3dB} is the input bandwidth in MHz of the AD7983 (10 MHz) or the cutoff frequency of the input filter, if one is used.

N is the noise gain of the amplifier (for example, 1 in buffer configuration).

e_N is the equivalent input noise voltage of the op amp, in nV/ $\sqrt{\text{Hz}}$.

- For ac applications, the driver should have a THD performance commensurate with the AD7983.
- For multichannel multiplexed applications, the driver amplifier and the AD7983 analog input circuit must settle for a full-scale step onto the capacitor array at a 16-bit level (0.0015%, 15 ppm). In the data sheet of the amplifier, settling at 0.1% to 0.01% is more commonly specified. This could differ significantly from the settling time at a 16-bit level and should be verified prior to driver selection.

Table 8. Recommended Driver Amplifiers

Amplifier	Typical Application
ADA4841-x	Very low noise, small and low power
AD8021	Very low noise and high frequency
AD8022	Low noise and high frequency
OP184	Low power, low noise, and low frequency
AD8655	5 V single-supply, low noise
AD8605, AD8615	5 V single-supply, low power

VOLTAGE REFERENCE INPUT

The AD7983 voltage reference input, REF, has a dynamic input impedance and should therefore be driven by a low impedance source with efficient decoupling between the REF and GND pins, as explained in the Layout section.

When REF is driven by a very low impedance source, for example, a reference buffer using the AD8031 or the AD8605, a ceramic chip capacitor is appropriate for optimum performance.

If an unbuffered reference voltage is used, the decoupling value depends on the reference used. For instance, a 22 μF (X5R, 1206 size) ceramic chip capacitor is appropriate for optimum performance using a low temperature drift ADR43x reference.

If desired, a reference-decoupling capacitor value as small as 2.2 μF can be used with a minimal impact on performance, especially DNL.

Regardless, there is no need for an additional lower value ceramic decoupling capacitor (for example, 100 nF) between the REF and GND pins.

POWER SUPPLY

The AD7983 uses two power supply pins: a core supply (VDD) and a digital input/output interface supply (VIO). VIO allows direct interface with any logic between 1.8 V and 5.0 V. To reduce the number of supplies needed, VIO and VDD can be tied together. The AD7983 is independent of power supply sequencing between VIO and VDD. Additionally, it is very insensitive to power supply variations over a wide frequency range, as shown in Figure 25.

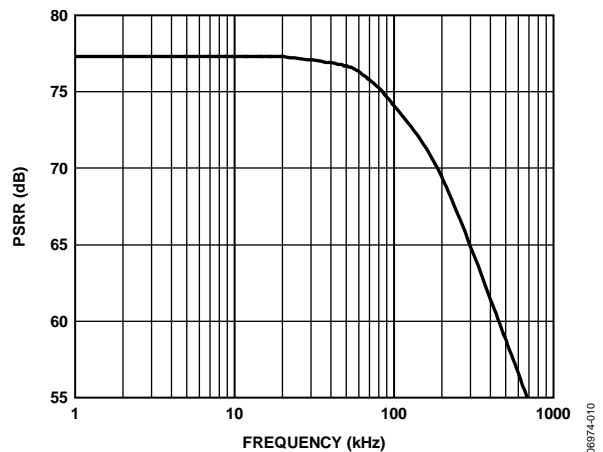

Figure 25. PSRR vs. Frequency

DIGITAL INTERFACE

Though the AD7983 has a reduced number of pins, it offers flexibility in its serial interface modes.

When in \overline{CS} mode, the AD7983 is compatible with SPI, QSPI, and digital hosts. This interface can use either a 3-wire or a 4-wire interface. A 3-wire interface using the CNV, SCK, and SDO signals minimizes wiring connections useful, for instance, in isolated applications. A 4-wire interface using the SDI, CNV, SCK, and SDO signals allows CNV, which initiates the conversions, to be independent of the readback timing (SDI). This is useful in low jitter sampling or simultaneous sampling applications.

The AD7983, when in chain mode, provides a daisy-chain feature using the SDI input for cascading multiple ADCs on a single data line similar to a shift register.

The mode in which the part operates depends on the SDI level when the CNV rising edge occurs. The \overline{CS} mode is selected if SDI is high, and the chain mode is selected if SDI is low. The SDI hold time is such that when SDI and CNV are connected, the chain mode is always selected.

In either mode, the AD7983 offers the flexibility to optionally force a start bit in front of the data bits. This start bit can be used as a busy signal indicator to interrupt the digital host and trigger the data reading. Otherwise, without a busy indicator, the user must time out the maximum conversion time prior to readback.

The busy indicator feature is enabled

- In \overline{CS} mode if CNV or SDI is low when the ADC conversion ends (see Figure 29 and Figure 33).
- In chain mode if SCK is high during the CNV rising edge (see Figure 37).

$\overline{\text{CS}}$ MODE, 3-WIRE WITHOUT BUSY INDICATOR

This mode is usually used when a single AD7983 is connected to an SPI-compatible digital host. The connection diagram is shown in Figure 26, and the corresponding timing is given in Figure 27.

With SDI tied to VIO, a rising edge on CNV initiates a conversion, selects the $\overline{\text{CS}}$ mode, and forces SDO to high impedance. When a conversion is initiated, it continues until completion irrespective of the state of CNV. This can be useful, for example, to bring CNV low to select other SPI devices, such as analog multiplexers; however, CNV must be returned high before the minimum conversion time elapses and then held high for the maximum conversion time to avoid the generation of the busy signal indicator. When the conversion is complete, the AD7983 enters the acquisition phase and goes into standby mode.

When CNV goes low, the MSB is output onto SDO. The remaining data bits are then clocked by subsequent SCK falling edges. The data is valid on both SCK edges. Although the rising edge can be used to capture the data, a digital host using the SCK falling edge allows a faster reading rate provided that it has an acceptable hold time. After the 16th SCK falling edge or when CNV goes high, whichever is earlier, SDO returns to high impedance.

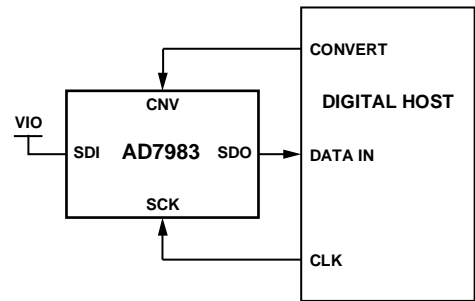

Figure 26. $\overline{\text{CS}}$ Mode, 3-Wire Without Busy Indicator Connection Diagram (SDI High)

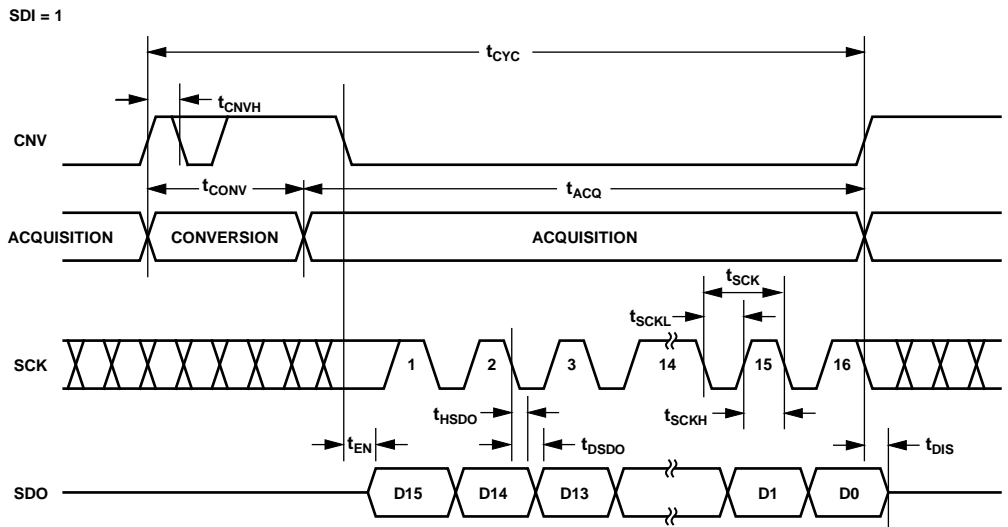

Figure 27. $\overline{\text{CS}}$ Mode, 3-Wire Without Busy Indicator Serial Interface Timing (SDI High)

$\overline{\text{CS}}$ MODE, 3-WIRE WITH BUSY INDICATOR

This mode is usually used when a single AD7983 is connected to an SPI-compatible digital host that has an interrupt input.

The connection diagram is shown in Figure 28, and the corresponding timing is given in Figure 29.

With SDI tied to VIO, a rising edge on CNV initiates a conversion, selects the $\overline{\text{CS}}$ mode, and forces SDO to high impedance. SDO is maintained in high impedance until the completion of the conversion irrespective of the state of CNV. Prior to the minimum conversion time, CNV can be used to select other SPI devices, such as analog multiplexers, but CNV must be returned low before the minimum conversion time elapses and then held low for the maximum conversion time to guarantee the generation of the busy signal indicator. When the conversion is complete, SDO goes from high impedance to low. With a pull-up on the SDO line, this transition can be used as an interrupt signal to initiate the data read back controlled by the digital host. The AD7983 then enters the acquisition phase and goes into standby mode. The data bits are then clocked out, MSB first, by subsequent SCK falling edges. The data is valid on both SCK edges. Although the rising edge can be used to capture the data, a digital host using the SCK falling edge allows a faster reading rate provided it has an acceptable hold time. After the optional 17th SCK falling edge or when CNV goes high, whichever is earlier, SDO returns to high impedance.

If multiple AD7983s are selected at the same time, the SDO output pin handles this contention without damage or induced latch-up. Meanwhile, it is recommended that this contention be kept as short as possible to limit extra power dissipation.

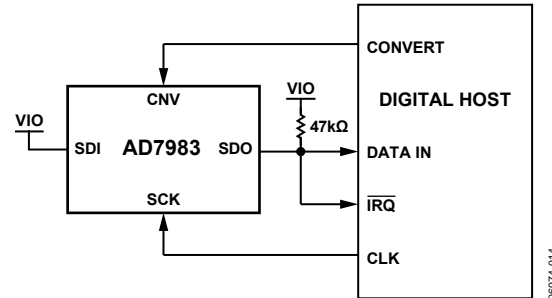

Figure 28. $\overline{\text{CS}}$ Mode, 3-Wire with Busy Indicator Connection Diagram (SDI High)

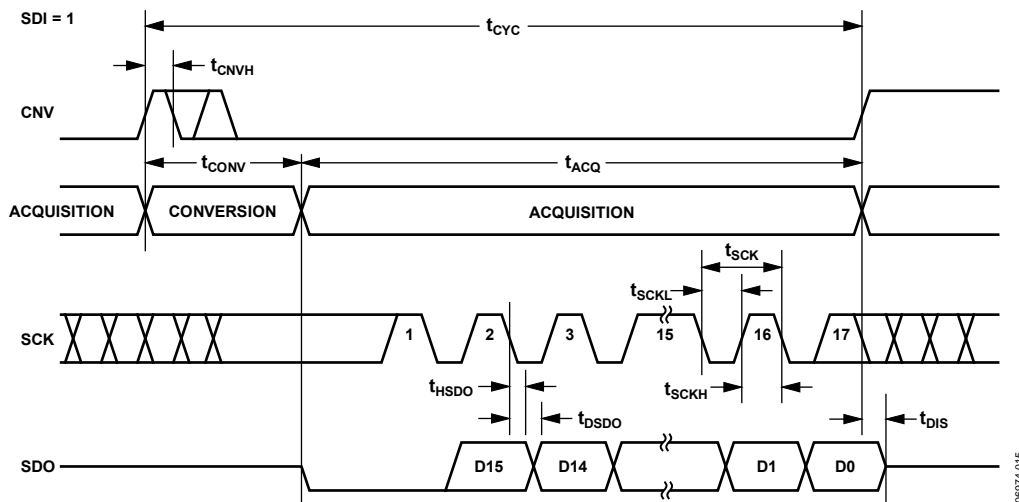

Figure 29. $\overline{\text{CS}}$ Mode, 3-Wire with Busy Indicator Serial Interface Timing (SDI High)

\overline{CS} MODE, 4-WIRE WITHOUT BUSY INDICATOR

This mode is usually used when multiple AD7983s are connected to an SPI-compatible digital host.

A connection diagram example using two AD7983s is shown in Figure 30, and the corresponding timing is given in Figure 31.

With SDI high, a rising edge on CNV initiates a conversion, selects the \overline{CS} mode, and forces SDO to high impedance. In this mode, CNV must be held high during the conversion phase and the subsequent data readback (if SDI and CNV are low, SDO is driven low). Prior to the minimum conversion time, SDI can be used to select other SPI devices, such as analog multiplexers, but SDI must be returned high before the minimum conversion time elapses and then held high for the maximum conversion time to avoid the generation of the busy signal indicator.

When the conversion is complete, the AD7983 enters the acquisition phase and goes into standby mode. Each ADC result can be read by bringing its SDI input low, which consequently outputs the MSB onto SDO. The remaining data bits are then clocked by subsequent SCK falling edges. The data is valid on both SCK edges. Although the rising edge can be used to capture the data, a digital host using the SCK falling edge allows a faster reading rate provided it has an acceptable hold time. After the 16th SCK falling edge or when SDI goes high, whichever is earlier, SDO returns to high impedance and another AD7983 can be read.

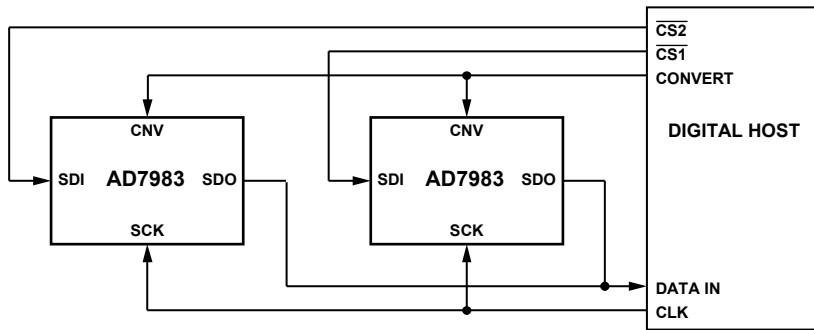

Figure 30. \overline{CS} Mode, 4-Wire Without Busy Indicator Connection Diagram

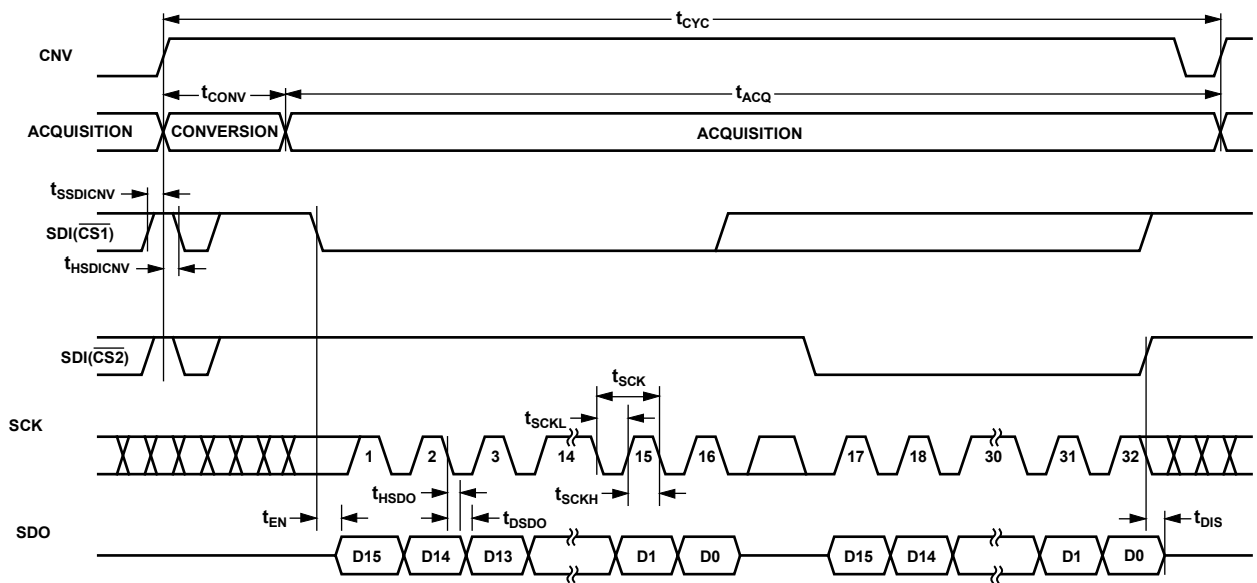

Figure 31. \overline{CS} Mode, 4-Wire Without Busy Indicator Serial Interface Timing

\overline{CS} MODE, 4-WIRE WITH BUSY INDICATOR

This mode is usually used when a single AD7983 is connected to an SPI-compatible digital host that has an interrupt input, and when it is desired to keep CNV, which is used to sample the analog input, independent of the signal used to select the data reading. This requirement is particularly important in applications where low jitter on CNV is desired.

The connection diagram is shown in Figure 32, and the corresponding timing is given in Figure 33.

With SDI high, a rising edge on CNV initiates a conversion, selects the \overline{CS} mode, and forces SDO to high impedance. In this mode, CNV must be held high during the conversion phase and the subsequent data readback (if SDI and CNV are low, SDO is driven low). Prior to the minimum conversion time, SDI can be used to select other SPI devices, such as analog multiplexers, but SDI must be returned low before the minimum conversion time elapses and then held low for the maximum conversion time to guarantee the generation of the busy signal indicator. When the conversion is complete, SDO goes from high impedance to low.

With a pull-up on the SDO line, this transition can be used as an interrupt signal to initiate the data readback controlled by the digital host. The AD7983 then enters the acquisition phase and goes into standby mode. The data bits are clocked out, MSB first, by subsequent SCK falling edges. The data is valid on both SCK edges. Although the rising edge can be used to capture the data, a digital host using the SCK falling edge allows a faster reading rate provided it has an acceptable hold time. After the optional 17th SCK falling edge or SDI going high, whichever is earlier, the SDO returns to high impedance.

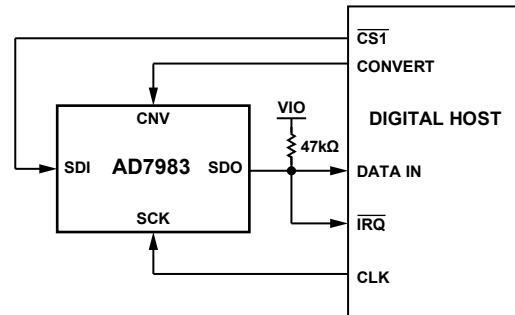

Figure 32. \overline{CS} Mode, 4-Wire with Busy Indicator Connection Diagram

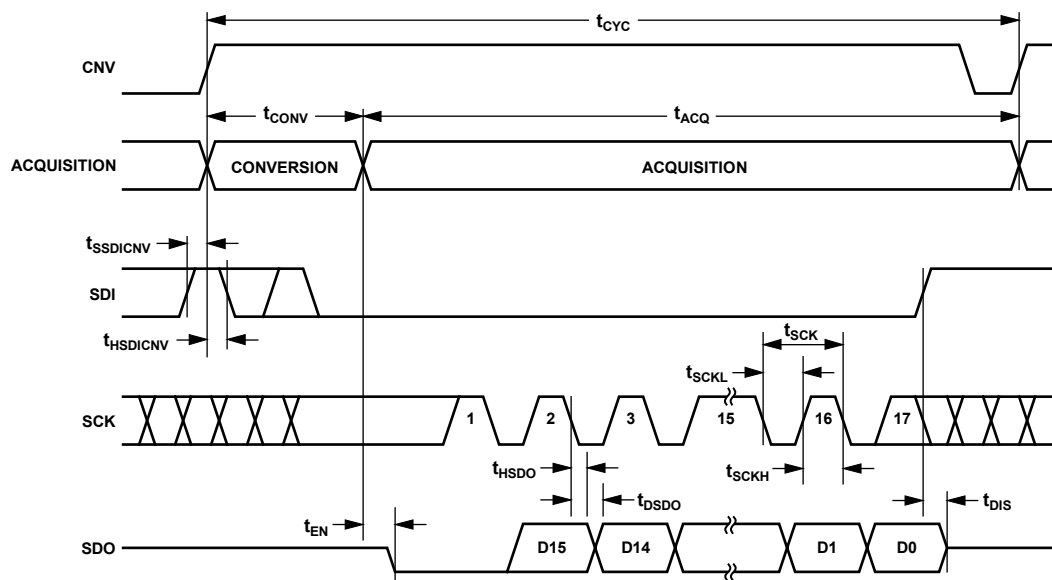

Figure 33. \overline{CS} Mode, 4-Wire with Busy Indicator Serial Interface Timing

CHAIN MODE WITHOUT BUSY INDICATOR

This mode can be used to daisy-chain multiple AD7983s on a 3-wire serial interface. This feature is useful for reducing component count and wiring connections, for example, in isolated multiconverter applications or for systems with a limited interfacing capacity. Data readback is analogous to clocking a shift register.

A connection diagram example using two AD7983s is shown in Figure 34, and the corresponding timing is given in Figure 35.

When SDI and CNV are low, SDO is driven low. With SCK low, a rising edge on CNV initiates a conversion, selects the chain mode, and disables the busy indicator. In this mode, CNV is held high during the conversion phase and the subsequent data readback. When the conversion is complete, the MSB is output onto SDO and the AD7983 enters the acquisition phase and goes into standby mode. The remaining data bits stored in the internal shift register are clocked by subsequent SCK falling edges. For each ADC, SDI feeds the input of the internal shift register and is clocked by the SCK falling edge. Each ADC in the chain outputs its data MSB first, and $16 \times N$ clocks are required to readback the N ADCs. The data is valid on both SCK edges. Although the rising edge can be used to capture the data, a digital host using the SCK falling edge allows a faster reading rate and, consequently, more AD7983s in the chain, provided the digital host has an acceptable hold time. The maximum conversion rate can be reduced due to the total readback time.

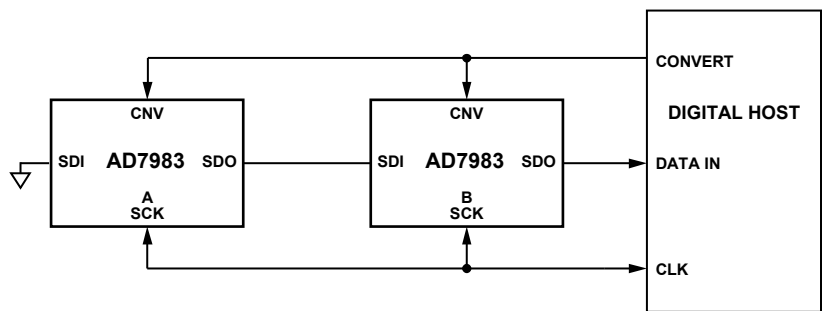

Figure 34. Chain Mode Without Busy Indicator Connection Diagram

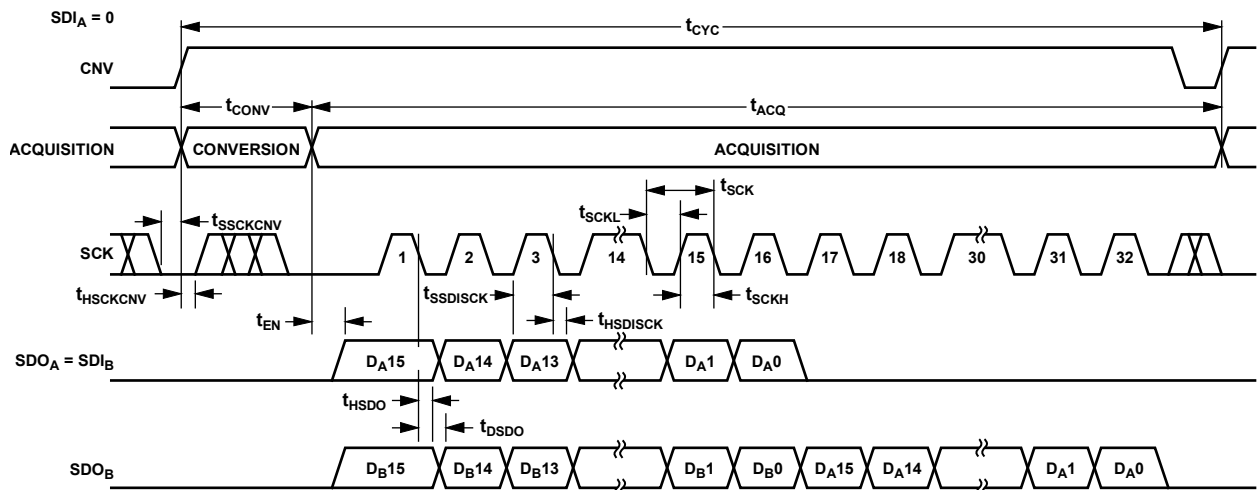

Figure 35. Chain Mode Without Busy Indicator Serial Interface Timing

CHAIN MODE WITH BUSY INDICATOR

This mode can also be used to daisy-chain multiple AD7983s on a 3-wire serial interface while providing a busy indicator. This feature is useful for reducing component count and wiring connections, for example, in isolated multiconverter applications or for systems with a limited interfacing capacity. Data readback is analogous to clocking a shift register.

A connection diagram example using three AD7983s is shown in Figure 36, and the corresponding timing is given in Figure 37.

When SDI and CNV are low, SDO is driven low. With SCK high, a rising edge on CNV initiates a conversion, selects the chain mode, and enables the busy indicator feature. In this mode, CNV is held high during the conversion phase and the subsequent data readback. When all ADCs in the chain have completed their conversions, the SDO pin of the ADC closest to the digital host (see the AD7983 ADC labeled C in Figure 36) is driven high. This transition on SDO can be used as a busy indicator to trigger the data readback controlled by the digital host. The AD7983 then enters the acquisition phase and goes into standby mode. The data bits stored in the internal shift register are clocked out, MSB first, by subsequent SCK falling edges. For each ADC, SDI feeds the input of the internal shift register and is clocked by the SCK falling edge. Each ADC in the chain outputs its data MSB first, and $16 \times N + 1$ clocks are required to readback the N ADCs. Although the rising edge can be used to capture the data, a digital host using the SCK falling edge allows a faster reading rate and, consequently, more AD7983s in the chain, provided the digital host has an acceptable hold time.

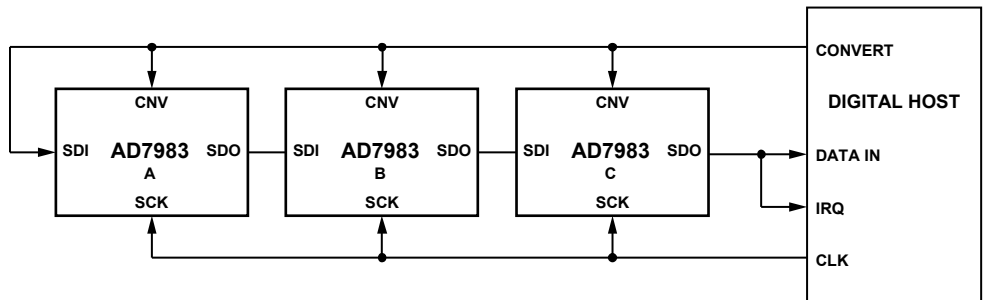

Figure 36. Chain Mode with Busy Indicator Connection Diagram

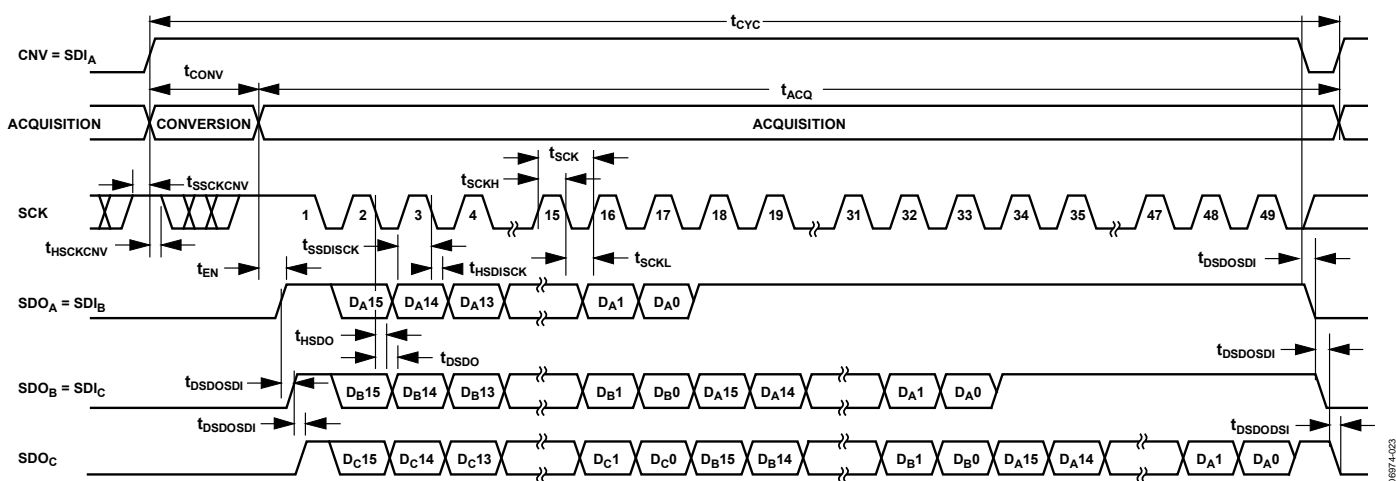

Figure 37. Chain Mode with Busy Indicator Serial Interface Timing

APPLICATION HINTS

LAYOUT

The printed circuit board (PCB) that houses the [AD7983](#) should be designed so that the analog and digital sections are separated and confined to certain areas of the board. The pinout of the [AD7983](#), with all its analog signals on the left side and all its digital signals on the right side, eases this task.

Avoid running digital lines under the device because these couple noise onto the die, unless a ground plane under the [AD7983](#) is used as a shield. Fast switching signals, such as CNV or clocks, should never run near analog signal paths. Crossover of digital and analog signals should be avoided.

At least one ground plane should be used. It can be common or split between the digital and analog section. In the latter case, the planes should be joined underneath the [AD7983](#).

The [AD7983](#) voltage reference input REF has a dynamic input impedance and should be decoupled with minimal parasitic inductances. This is done by placing the reference decoupling ceramic capacitor close to, ideally right up against, the REF and GND pins and connecting them with wide, low impedance traces.

Finally, the [AD7983](#) power supplies, VDD and VIO, should be decoupled with ceramic capacitors, typically 100 nF, placed close to the [AD7983](#) and connected using short and wide traces to provide low impedance paths and to reduce the effect of glitches on the power supply lines.

An example of a layout following these rules is shown in Figure 38 and Figure 39.

EVALUATING THE PERFORMANCE OF THE [AD7983](#)

Other recommended layouts for the [AD7983](#) are outlined in the documentation of the evaluation board for the [AD7983](#) ([EVAL-AD7983SDZ](#)). The evaluation board package includes a fully assembled and tested evaluation board, documentation, and software for controlling the board from a PC via the EVAL-SDP-CB1Z.

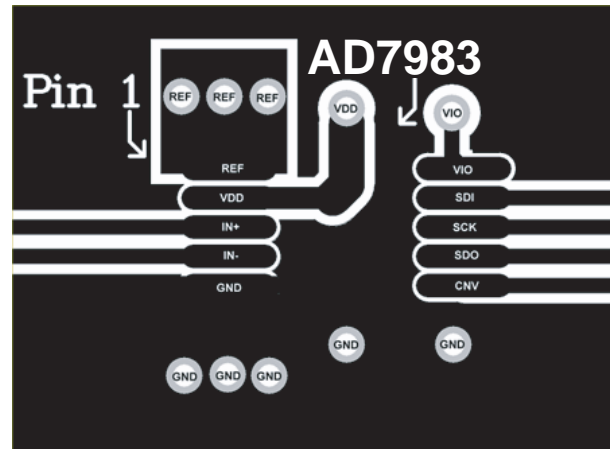

Figure 38. Example Layout of the [AD7983](#) (Top Layer)

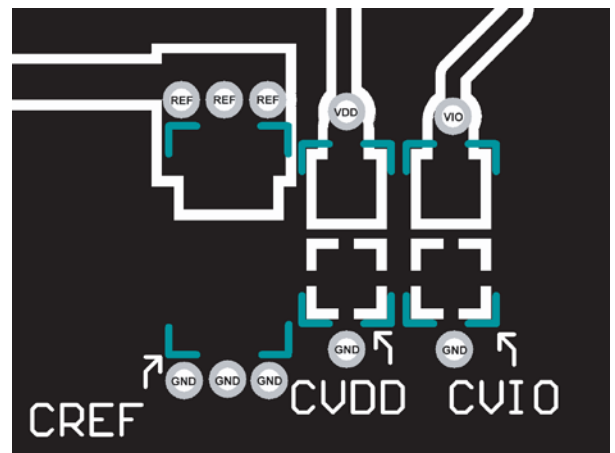

Figure 39. Example Layout of the [AD7983](#) (Bottom Layer)

Looking for pricing, stock, or lifecycle information?

Click below to explore more details on WIN SOURCE:

 [View AD7983BCPZ-RL7 on WIN SOURCE](#)

 [Analog Devices Inc. Information](#)

Optimize Your Supply Chain with WIN SOURCE Solutions

-  Global Sourcing Solution
-  Obsolete Management
-  Cost Control Management
-  Shortage Management
-  Alternative Solution
-  Excess Inventory Management