



**THE DATASHEET OF  
ADAU1772BCPZ-RL**



### FEATURES

- Programmable audio processing engine
  - 192 kHz processing path
  - Biquad filters, limiters, volume controls, mixing
- Low latency, 24-bit ADCs and DACs
  - 102 dB SNR (signal through PGA and ADC with A-weighted filter)
  - 107 dB combined SNR (signal through DAC and headphone with A-weighted filter)
- Serial port sample rates from 8 kHz to 192 kHz
- 38  $\mu$ s analog-to-analog latency
- 4 single-ended analog inputs—configurable as microphone or line inputs
- Dual stereo digital microphone inputs
- Stereo analog audio output—single-ended or differential, configurable as either line output or headphone driver
- PLL supporting any input clock rate from 8 MHz to 27 MHz
- Full-duplex, asynchronous sample rate converters (ASRCs)
- Power supplies
  - Analog and digital I/O of 1.8 V to 3.3 V
  - Digital signal processing (DSP) core of 1.1 V to 1.8 V

- Low power (15 mW for typical noise cancelling solution)
- I<sup>2</sup>C and SPI control interfaces, self-boot from I<sup>2</sup>C EEPROM
- 7 MP pins supporting dual stereo digital microphone inputs, stereo PDM output, mute, DSP bypass, push-button volume controls, and parameter bank switching

### APPLICATIONS

- Noise cancelling handsets, headsets, and headphones
- Bluetooth ANC handsets, headsets, and headphones
- Personal navigation devices
- Digital still and video cameras

### GENERAL DESCRIPTION

The ADAU1772 is a codec with four inputs and two outputs that incorporates a digital processing engine to perform filtering, level control, signal level monitoring, and mixing. The path from the analog input to the DSP core to the analog output is optimized for low latency and is ideal for noise cancelling headsets. With the addition of just a few passive components, a crystal, and an EEPROM for booting, the ADAU1772 provides a complete headset solution.

### FUNCTIONAL BLOCK DIAGRAM

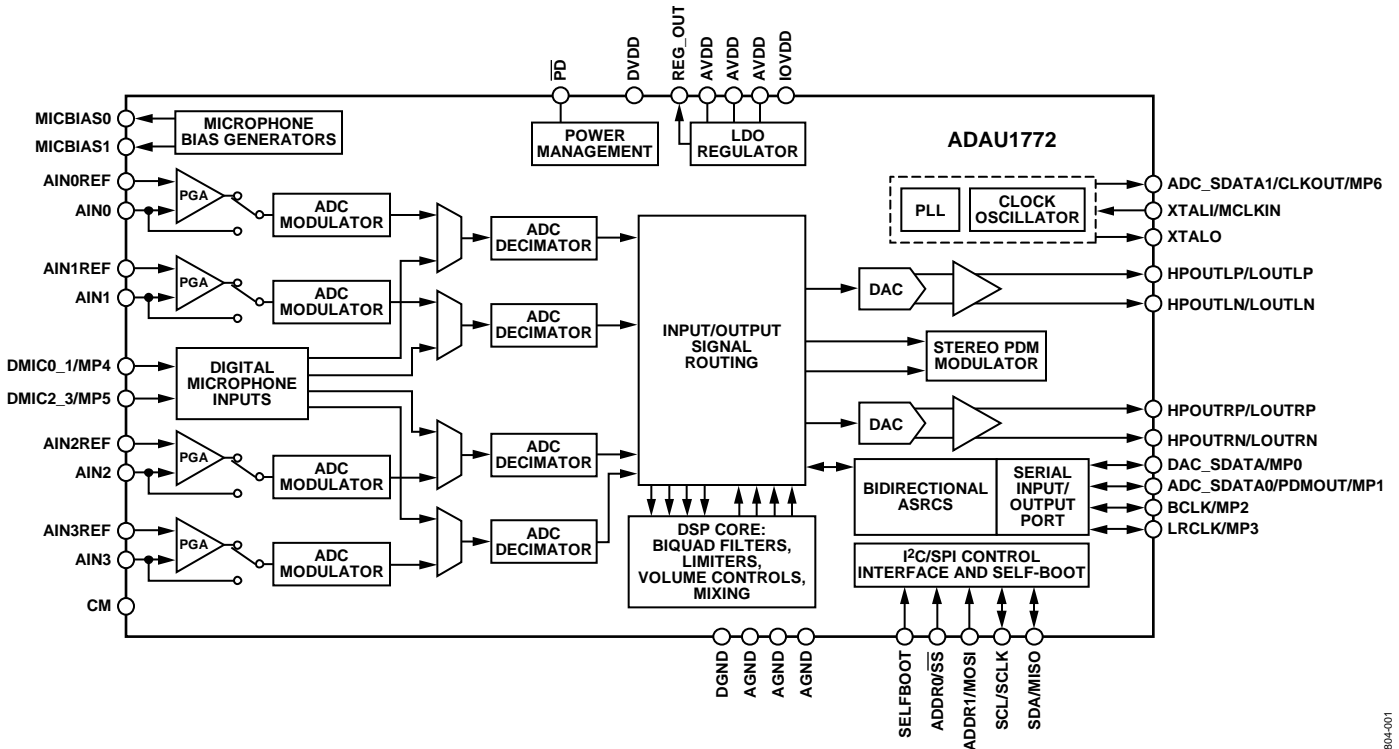

Figure 1.

Rev. C [Document Feedback](#)  
 Information furnished by Analog Devices is believed to be accurate and reliable. However, no responsibility is assumed by Analog Devices for its use, nor for any infringements of patents or other rights of third parties that may result from its use. Specifications subject to change without notice. No license is granted by implication or otherwise under any patent or patent rights of Analog Devices. Trademarks and registered trademarks are the property of their respective owners.

One Technology Way, P.O. Box 9106, Norwood, MA 02062-9106, U.S.A.  
 Tel: 781.329.4700 ©2012–2014 Analog Devices, Inc. All rights reserved.  
[Technical Support](#) [www.analog.com](http://www.analog.com)

## TABLE OF CONTENTS

Features .....	1	Control Port .....	40
Applications.....	1	I <sup>2</sup> C Port .....	40
General Description .....	1	SPI Port .....	43
Functional Block Diagram .....	1	Self-Boot .....	44
Revision History .....	3	Multipurpose Pins .....	45
Specifications.....	4	Push-Button Volume Controls .....	45
Analog Performance Specifications .....	4	Limiter Compression Enable .....	45
Crystal Amplifier Specifications.....	7	Parameter Bank Switching .....	45
Digital Input/Output Specifications.....	8	Mute .....	45
Power Supply Specifications.....	8	DSP Bypass Mode .....	46
Typical Power Consumption.....	9	Serial Data Input/Output Ports .....	47
Digital Filters.....	9	Tristating Unused Channels.....	47
Digital Timing Specifications .....	10	Applications Information .....	50
Absolute Maximum Ratings.....	14	Power Supply Bypass Capacitors.....	50
Thermal Resistance .....	14	Layout .....	50
ESD Caution.....	14	Grounding.....	50
Pin Configuration and Function Descriptions.....	15	Exposed Pad PCB Design .....	50
Typical Performance Characteristics .....	17	Register Summary .....	51
System Block Diagrams .....	28	Register Details .....	53
Theory of Operation .....	29	Clock Control Register .....	53
System Clocking and Power-Up.....	30	PLL Denominator MSB Register.....	54
Clock Initialization.....	30	PLL Denominator LSB Register .....	54
PLL .....	30	PLL Numerator MSB Register .....	54
Clock Output.....	31	PLL Numerator LSB Register.....	55
Power Sequencing .....	31	PLL Integer Setting Register .....	55
Signal Routing.....	32	PLL Lock Flag Register .....	56
Input Signal Paths.....	33	CLKOUT Setting Selection Register.....	56
Analog Inputs.....	33	Regulator Control Register .....	57
Digital Microphone Input .....	34	Core Control Register.....	58
Analog-to-Digital Converters.....	34	Filter Engine and Limiter Control Register .....	59
Output Signal Paths.....	35	DB Value Register 0 Read.....	60
Analog Outputs.....	35	DB Value Register 1 Read.....	60
Digital-to-Analog Converters.....	35	DB Value Register 2 Read.....	61
PDM Output .....	35	Core Channel 0/Core Channel 1 Input Select Register.....	62
Asynchronous Sample Rate Converters .....	36	Core Channel 2/Core Channel 3 Input Select Register.....	63
Signal Levels .....	36	DAC Input Select Register .....	64
Signal Processing .....	37	PDM Modulator Input Select Register .....	65
Instructions .....	37	Serial Data Output 0/Serial Data Output 1 Input Select Register .....	66
Data Memory .....	37		
Parameters.....	37		

Serial Data Output 2/Serial Data Output 3 Input Select Register .....	67
Serial Data Output 4/Serial Data Output 5 Input Select Register .....	68
Serial Data Output 6/Serial Data Output 7 Input Select Register .....	69
ADC_SDATA0/ADC_SDATA1 Channel Select Register.....	70
Output ASRC0/Output ASRC1 Source Register.....	71
Output ASRC2/Output ASRC3 Source Register.....	72
Input ASRC Channel Select Register.....	73
ADC0/ADC1 Control 0 Register .....	74
ADC2/ADC3 Control 0 Register .....	75
ADC0/ADC1 Control 1 Register .....	76
ADC2/ADC3 Control 1 Register .....	77
ADC0 Volume Control Register .....	78
ADC1 Volume Control Register .....	78
ADC2 Volume Control Register .....	79
ADC3 Volume Control Register .....	79
PGA Control 0 Register.....	80
PGA Control 1 Register.....	80
PGA Control 2 Register.....	81
PGA Control 3 Register.....	82
PGA Slew Control Register.....	83
PGA 10 dB Gain Boost Register.....	84
Input and Output Capacitor Charging Register .....	85
DSP Bypass Path Register .....	86
DSP Bypass Gain for PGA0 Register .....	86
DSP Bypass Gain for PGA1 Register .....	86
MIC_BIAS0_1 Control Register .....	87
DAC Control Register .....	87
DAC0 Volume Control Register.....	88
DAC1 Volume Control Register.....	88

## REVISION HISTORY

### 3/14—Rev. B to Rev. C

Changes to Figure 60 and Figure 62 Captions .....	25
Added Figure 64, Figure 65, Figure 66, Figure 67, Figure 68, and Figure 69, Renumbered Sequentially .....	26
Added Figure 70, and Figure 71 .....	27

### 12/12—Rev. A to Rev. B

Changes to Figure 90 .....	47
----------------------------	----

Headphone Output Mutes Register .....	89
Serial Port Control 0 Register.....	90
Serial Port Control 1 Register.....	91
TDM Output Channel Disable Register .....	92
PDM Enable Register .....	93
PDM Pattern Setting Register .....	94
MP0 Function Setting Register .....	94
MP1 Function Setting Register .....	95
MP2 Function Setting Register .....	96
MP3 Function Setting Register .....	97
MP4 Function Setting Register .....	98
MP5 Function Setting Register .....	99
MP6 Function Setting Register .....	100
Push-Button Volume Settings Register .....	101
Push-Button Volume Control Assignment Register .....	102
Debounce Modes Register .....	103
Headphone Line Output Select Register.....	103
Decimator Power Control Register .....	105
ASRC Interpolator and DAC Modulator Power Control Register .....	106
Analog Bias Control 0 Register .....	106
Analog Bias Control 1 Register .....	107
Digital Pin Pull-Up Control 0 Register .....	108
Digital Pin Pull-Up Control 1 Register .....	109
Digital Pin Pull-Down Control 0 Register .....	110
Digital Pin Pull-Down Control 1 Register .....	111
Digital Pin Drive Strength Control 0 Register .....	112
Digital Pin Drive Strength Control 1 Register .....	113
Outline Dimensions.....	114
Ordering Guide .....	114

### 8/12—Rev. 0 to Rev. A

Changes to Figure 69 .....	31
----------------------------	----

### 7/12—Revision 0: Initial Version

## SPECIFICATIONS

Master clock = core clock = 12.288 MHz, serial input sample rate = 48 kHz, measurement bandwidth = 20 Hz to 20 kHz, word width = 24 bits, ambient temperature = 25°C, outputs line loaded with 10 kΩ.

### ANALOG PERFORMANCE SPECIFICATIONS

Supply voltages AVDD = IOVDD = 1.8 V, DVDD = 1.1 V, unless otherwise noted. PLL disabled, direct master clock.

Table 1.

Parameter	Test Conditions/Comments	Min	Typ	Max	Unit
<b>ANALOG-TO-DIGITAL CONVERTERS</b>					
ADC Resolution	All ADCs		24		Bits
Digital Attenuation Step			0.375		dB
Digital Attenuation Range			95		dB
<b>INPUT RESISTANCE</b>					
Single-Ended Line Input	Gain settings do not include 10 dB gain from PGA_x_BOOST settings; this additional gain does not affect input impedance; PGA_POP_DISx = 1 0 dB gain		14.3		kΩ
PGA Inputs	−12 dB gain		32.0		kΩ
	0 dB gain		20		kΩ
	+35.25 dB gain		0.68		kΩ
<b>SINGLE-ENDED LINE INPUT</b>					
Full-Scale Input Voltage	PGA_ENx = 0, PGA_x_BOOST = 0, PGA_POP_DISx = 1 Scales linearly with AVDD		AVDD/3.63		V rms
	AVDD = 1.8 V		0.49		V rms
	AVDD = 1.8 V, 0 dBFS		1.38		V p-p
	AVDD = 3.3 V		0.90		V rms
	AVDD = 3.3 V, 0 dBFS		2.54		V p-p
Dynamic Range <sup>1</sup>	20 Hz to 20 kHz, −60 dB input				
With A-Weighted Filter (RMS)	AVDD = 1.8 V		97		dB
	AVDD = 3.3 V		102		dB
With Flat 20 Hz to 20 kHz Filter	AVDD = 1.8 V		94		dB
	AVDD = 3.3 V		99		dB
Signal-to-Noise Ratio (SNR) <sup>2</sup>					
With A-Weighted Filter (RMS)	AVDD = 1.8 V		98		dB
	AVDD = 3.3 V		103		dB
With Flat 20 Hz to 20 kHz Filter	AVDD = 1.8 V		96		dB
	AVDD = 3.3 V		100		dB
Interchannel Gain Mismatch			40		mdB
Total Harmonic Distortion + Noise (THD + N)	20 Hz to 20 kHz, −1 dBFS				
	AVDD = 1.8 V		−90		dB
	AVDD = 3.3 V		−94		dB
Offset Error			±0.1		mV
Gain Error			±0.2		dB
Interchannel Isolation	CM capacitor = 22 μF		100		dB
Power Supply Rejection Ratio	CM capacitor = 22 μF 100 mV p-p at 1 kHz		55		dB
<b>SINGLE-ENDED PGA INPUT</b>					
Full-Scale Input Voltage	PGA_ENx = 1, PGA_x_BOOST = 0 Scales linearly with AVDD		AVDD/3.63		V rms
	AVDD = 1.8 V		0.49		V rms
	AVDD = 1.8 V, 0 dBFS		1.38		V p-p
	AVDD = 3.3 V		0.90		V rms
	AVDD = 3.3 V, 0 dBFS		2.54		V p-p
Dynamic Range <sup>1</sup>	20 Hz to 20 kHz, −60 dB input				
With A-Weighted Filter (RMS)	AVDD = 1.8 V		96		dB
	AVDD = 3.3 V		102		dB
With Flat 20 Hz to 20 kHz Filter	AVDD = 1.8 V		94		dB
	AVDD = 3.3 V		99		dB

Parameter	Test Conditions/Comments	Min	Typ	Max	Unit
Total Harmonic Distortion + Noise	20 Hz to 20 kHz, -1 dBFS AVDD = 1.8 V AVDD = 3.3 V		-88 -90		dB dB
Signal-to-Noise Ratio <sup>2</sup> With A-Weighted Filter (RMS)	AVDD = 1.8 V AVDD = 3.3 V		96 102		dB dB
With Flat 20 Hz to 20 kHz Filter	AVDD = 1.8 V AVDD = 3.3 V		94 99		dB dB
PGA Gain Variation With -12 dB Setting	Standard deviation		0.05		dB
With +35.25 dB Setting	Standard deviation		0.15		dB
PGA Boost	PGA_x_BOOST		10		dB
PGA Mute Attenuation	PGA_MUTEx		-65		dB
Interchannel Gain Mismatch			0.005		dB
Offset Error			0		mV
Gain Error			±0.2		dB
Interchannel Isolation			83		dB
Power Supply Rejection Ratio	CM capacitor = 22 µF, 100 mV p-p at 1 kHz		63		dB
MICROPHONE BIAS	MIC_ENx = 1				
Bias Voltage 0.65 × AVDD	AVDD = 1.8 V, MIC_GAINx = 1 AVDD = 3.3 V, MIC_GAINx = 1		1.16 2.12		V V
0.90 × AVDD	AVDD = 1.8 V, MIC_GAINx = 0 AVDD = 3.3 V, MIC_GAINx = 0		1.63 2.97		V V
Bias Current Source				3	mA
Output Impedance			1		Ω
MICBIASx Isolation	MIC_GAINx = 0 MIC_GAINx = 1		95 99		dB dB
Noise in the Signal Bandwidth <sup>3</sup>	AVDD = 1.8 V, 20 Hz to 20 kHz MIC_GAINx = 0 MIC_GAINx = 1 AVDD = 3.3 V, 20 Hz to 20 kHz MIC_GAINx = 0 MIC_GAINx = 1		27 16 35 19		nV/√Hz nV/√Hz nV/√Hz nV/√Hz
DIGITAL-TO-ANALOG CONVERTERS					
DAC Resolution	All DACs		24		Bits
Digital Attenuation Step			0.375		dB
Digital Attenuation Range			95		dB
DAC SINGLE-ENDED OUTPUT	Single-ended operation, HPOUTLP and HPOUTRP pins				
Full-Scale Output Voltage	Scales linearly with AVDD AVDD = 1.8 V AVDD = 1.8 V, 0 dBFS AVDD = 3.3 V AVDD = 3.3 V, 0 dBFS		AVDD/3.4 0.53 1.5 0.97 2.74		V rms V rms V p-p V rms V p-p
Mute Attenuation			-72		dB
Dynamic Range <sup>1</sup> With A-Weighted Filter (RMS)	Line output mode, 20 Hz to 20 kHz, -60 dB input AVDD = 1.8 V AVDD = 3.3 V		100 104		dB dB
With Flat 20 Hz to 20 kHz Filter	AVDD = 1.8 V AVDD = 3.3 V		97 101		dB dB
Signal-to-Noise Ratio <sup>2</sup> With A-Weighted Filter (RMS)	Line output mode, 20 Hz to 20 kHz AVDD = 1.8 V AVDD = 3.3 V		100 104		dB dB
With Flat 20 Hz to 20 kHz Filter	AVDD = 1.8 V AVDD = 3.3 V		98 102		dB dB

Parameter	Test Conditions/Comments	Min	Typ	Max	Unit
Interchannel Gain Mismatch	Line output mode		20		mdB
Total Harmonic Distortion + Noise	Line output mode, 20 Hz to 20 kHz, -1 dBFS				dB
	AVDD = 1.8 V		-93		dB
	AVDD = 3.3 V		-94		dB
Gain Error	Line output mode		±0.1		dB
Dynamic Range <sup>1</sup>	Headphone mode, 20 Hz to 20 kHz, -60 dB input				
With A-Weighted Filter (RMS)	AVDD = 1.8 V		100		dB
	AVDD = 3.3 V		104		dB
With Flat 20 Hz to 20 kHz Filter	AVDD = 1.8 V		97		dB
	AVDD = 3.3 V		101		dB
Signal-to-Noise Ratio <sup>2</sup>	Headphone mode, 20 Hz to 20 kHz				
With A-Weighted Filter (RMS)	AVDD = 1.8 V		100		dB
	AVDD = 3.3 V		104		dB
With Flat 20 Hz to 20 kHz Filter	AVDD = 1.8 V		98		dB
	AVDD = 3.3 V		102		dB
Interchannel Gain Mismatch	Headphone mode		50		mdB
Total Harmonic Distortion + Noise	Headphone mode, 20 Hz to 20 kHz, -1 dBFS				
32 Ω load	AVDD = 1.8 V, P <sub>o</sub> = 6.7 mW		-77		dB
	AVDD = 3.3 V, P <sub>o</sub> = 22.4 mW		-80		dB
24 Ω load	AVDD = 1.8 V, P <sub>o</sub> = 8.9 mW		-76		dB
	AVDD = 3.3 V, P <sub>o</sub> = 30 mW		-79		dB
16 Ω load	AVDD = 1.8 V, P <sub>o</sub> = 13 mW		-74		dB
	AVDD = 3.3 V, P <sub>o</sub> = 44 mW		-77		dB
Headphone Output Power					
32 Ω Load	AVDD = 1.8 V, <0.1% THD + N		8.4		mW
	AVDD = 3.3 V, <0.1% THD + N		28.1		mW
24 Ω Load	AVDD = 1.8 V, <0.1% THD + N		11.2		mW
	AVDD = 3.3 V, <0.1% THD + N		37.4		mW
16 Ω Load	AVDD = 1.8 V, <0.1% THD + N		16.25		mW
	AVDD = 3.3 V, <0.1% THD + N		55.8		mW
Gain Error	Headphone mode		±0.1		dB
Offset Error			±0.1		mV
Interchannel Isolation	1 kHz, 0 dBFS input signal		100		dB
Power Supply Rejection Ratio	CM capacitor = 22 μF, 100 mV p-p at 1 kHz		70		dB
<b>DAC DIFFERENTIAL OUTPUT</b>					
Full-Scale Output Voltage	Differential operation				
	Scales linearly with AVDD		AVDD/1.8		V <sub>rms</sub>
	AVDD = 1.8 V		1.0		V <sub>rms</sub>
	AVDD = 1.8 V, 0 dBFS		2.58		V <sub>p-p</sub>
	AVDD = 3.3 V		1.83		V <sub>rms</sub>
	AVDD = 3.3 V, 0 dBFS		5.49		V <sub>p-p</sub>
Mute Attenuation			-72		dB
Dynamic Range <sup>1</sup>	Line output mode, 20 Hz to 20 kHz, -60 dB input				
With A-Weighted Filter (RMS)	AVDD = 1.8 V		104		dB
	AVDD = 3.3 V		107		dB
With Flat 20 Hz to 20 kHz Filter	AVDD = 1.8 V		101		dB
	AVDD = 3.3 V		105		dB
Signal-to-Noise Ratio <sup>2</sup>	Line output mode, 20 Hz to 20 kHz				
With A-Weighted Filter (RMS)	AVDD = 1.8 V		105		dB
	AVDD = 3.3 V		108		dB
With Flat 20 Hz to 20 kHz Filter	AVDD = 1.8 V		102		dB
	AVDD = 3.3 V		105		dB
Interchannel Gain Mismatch	Line output mode		20		mdB
Total Harmonic Distortion + Noise	Line output mode, 20 Hz to 20 kHz, -1 dBFS				
	AVDD = 1.8 V		-96		dB
	AVDD = 3.3 V		-96		dB
Gain Error	Line output mode				%

Parameter	Test Conditions/Comments	Min	Typ	Max	Unit
Dynamic Range <sup>1</sup>	Headphone mode, 20 Hz to 20 kHz, –60 dB input				
With A-Weighted Filter (RMS)	AVDD = 1.8 V		104		dB
	AVDD = 3.3 V		107		dB
With Flat 20 Hz to 20 kHz Filter	AVDD = 1.8 V		102		dB
	AVDD = 3.3 V		104		dB
Signal-to-Noise Ratio <sup>2</sup>	Headphone mode, 20 Hz to 20 kHz				
With A-Weighted Filter (RMS)	AVDD = 1.8 V		105		dB
	AVDD = 3.3 V		108		dB
With Flat 20 Hz to 20 kHz Filter	AVDD = 1.8 V		103		dB
	AVDD = 3.3 V		106		dB
Interchannel Gain Mismatch	Headphone mode		75		mdB
Total Harmonic Distortion + Noise	Headphone mode				
32 Ω Load	–1 dBFS, AVDD = 1.8 V, P <sub>o</sub> = 27 mW		–75		dB
	–1 dBFS, AVDD = 3.3 V, P <sub>o</sub> = 90 mW		–83		dB
24 Ω Load	–2 dBFS, AVDD = 1.8 V, P <sub>o</sub> = 28 mW		–75		dB
	–1 dBFS, AVDD = 3.3 V, P <sub>o</sub> = 118 mW		–77		dB
16 Ω Load	–3 dBFS, AVDD = 1.8 V, P <sub>o</sub> = 33 mW		–75		dB
	–1 dBFS, AVDD = 3.3 V, P <sub>o</sub> = 175 mW		–83		dB
Headphone Output Power					
32 Ω Load	AVDD = 1.8 V, <0.1% THD + N		32.5		mW
	AVDD = 3.3 V, <0.1% THD + N		111.8		mW
24 Ω Load	AVDD = 1.8 V, <0.1% THD + N		37.6		mW
	AVDD = 3.3 V, <0.1% THD + N		148.3		mW
16 Ω Load	AVDD = 1.8 V, <0.1% THD + N		41.5		mW
	AVDD = 3.3 V, <0.1% THD + N		189.2		mW
Gain Error	Headphone mode		±0.25		%
Offset Error			±0.1		mV
Interchannel Isolation	1 kHz, 0 dBFS input signal		100		dB
Power Supply Rejection Ratio	CM capacitor = 22 μF 100 mV p-p at 1 kHz		73		dB
CM REFERENCE	CM pin				
Common-Mode Reference Output			AVDD/2		V
Common-Mode Source Impedance			5		kΩ
REGULATOR					
Line Regulation			1		mV/V
Load Regulation			6		mV/mA

<sup>1</sup> Dynamic range is the ratio of the sum of noise and harmonic power in the band of interest with a –60 dBFS signal present to the full-scale power level in decibels.

<sup>2</sup> SNR is the ratio of the sum of all noise power in the band of interest with no signal present to the full-scale power level in decibels.

<sup>3</sup> These specifications are with 4.7 μF decoupling and 5.0 kΩ load on pin.

## CRYSTAL AMPLIFIER SPECIFICATIONS

Supply voltages AVDD = IOVDD = 1.8 V, DVDD = 1.1 V, unless otherwise noted.

Table 2.

Parameter	Test Conditions/Comments	Min	Typ	Max	Unit
Jitter			270	500	ps
Frequency Range		8		27	MHz
Load Capacitance				20	pF

**DIGITAL INPUT/OUTPUT SPECIFICATIONS**

-40°C < T<sub>A</sub> < +85°C, IOVDD = 3.3 V ± 10% and 1.8 V - 5%/+10%.

Table 3.

Parameter	Test Conditions/Comments	Min	Typ	Max	Unit
Input Voltage High (V <sub>IH</sub> )	IOVDD = 3.3 V	2.0			V
	IOVDD = 1.8 V	1.1			V
Input Voltage Low (V <sub>IL</sub> )	IOVDD = 3.3 V			0.8	V
	IOVDD = 1.8 V			0.45	V
Input Leakage	IOVDD = 3.3 V, I <sub>IH</sub> at V <sub>IH</sub> = 2.0 V			10	μA
	I <sub>IL</sub> at V <sub>IL</sub> = 0.8 V			10	μA
	IOVDD = 1.8 V, I <sub>IH</sub> at V <sub>IH</sub> = 1.1 V			10	μA
	I <sub>IL</sub> at V <sub>IL</sub> = 0.45 V			10	μA
Output Voltage High (V <sub>OH</sub> ) with Low Drive Strength	I <sub>OH</sub> = 1 mA	IOVDD - 0.6			V
Output Voltage High (V <sub>OH</sub> ) with High Drive Strength	I <sub>OH</sub> = 3 mA	IOVDD - 0.6			V
Output Voltage Low (V <sub>OL</sub> ) with Low Drive Strength	I <sub>OL</sub> = 1 mA			0.4	V
Output Voltage Low (V <sub>OL</sub> ) with High Drive Strength	I <sub>OL</sub> = 3 mA			0.4	V
Input Capacitance				5	pF

**POWER SUPPLY SPECIFICATIONS**

Supply voltages AVDD = IOVDD = 1.8 V, DVDD = 1.1 V, unless otherwise noted. PLL disabled, direct master clock.

Table 4.

Parameter	Test Conditions/Comments	Min	Typ	Max	Unit
<b>SUPPLIES</b>					
AVDD Voltage		1.71	1.8	3.63	V
DVDD Voltage		1.045	1.1	1.98	V
IOVDD Voltage		1.71	1.8	3.63	V
Digital I/O Current with IOVDD = 1.8 V	Crystal oscillator enabled				
Slave Mode	f <sub>S</sub> = 48 kHz		0.35		mA
	f <sub>S</sub> = 192 kHz		0.49		mA
	f <sub>S</sub> = 8 kHz		0.32		mA
Master Mode	f <sub>S</sub> = 48 kHz		0.53		mA
	f <sub>S</sub> = 192 kHz		1.18		mA
	f <sub>S</sub> = 8 kHz		0.35		mA
Power-Down			0		μA
Digital I/O Current with IOVDD = 3.3 V	Crystal oscillator enabled				
Slave Mode	f <sub>S</sub> = 48 kHz		2.05		mA
	f <sub>S</sub> = 192 kHz		2.28		mA
	f <sub>S</sub> = 8 kHz		1.99		mA
Master Mode	f <sub>S</sub> = 48 kHz		2.4		mA
	f <sub>S</sub> = 192 kHz		3.62		mA
	f <sub>S</sub> = 8 kHz		2.05		mA
Power-Down			7		μA
Analog Current (AVDD)	See Table 5				
Power-Down	AVDD = 1.8 V		0.6		μA
	AVDD = 3.3 V		13.6		μA
<b>DISSIPATION</b>					
Operation	f <sub>S</sub> = 192 kHz (see conditions in Table 5)				
All Supplies			15.5		mW
Digital I/O Supply			0.7		mW
Analog Supply	Includes regulated DVDD current		14.8		mW
Power-Down, All Supplies			1		μW

## TYPICAL POWER CONSUMPTION

Typical active noise cancelling (ANC) settings. Master clock = 12.288 MHz,  $f_s = 192$  kHz. On-board regulator enabled. Two analog-to-digital converters (ADCs) with PGA enabled and two ADCs configured for line input; no input signal. Two digital-to-analog converters (DACs) configured for differential headphone operation; DAC outputs unloaded. Both MICBIAS0 and MICBIAS1 enabled. ASRCs and pulse density modulated (PDM) modulator disabled. Core running 26 out of 32 possible instructions. For total power consumption, add IOVDD at 8 kHz slave current listed in Table 4.

Table 5.

Operating Voltage	Power Management Setting	Typical AVDD Power Consumption (mA)	Typical ADC THD + N (dB)	Typical HP Output THD + N (dB)
AVDD = IOVDD = 3.3 V	Normal (default)	11.5	-93	-87.5
	Extreme power saving	9.4	-93	-86.5
	Power saving	9.8	-93	-86.5
	Enhanced performance	12.65	-93	-90.5
AVDD = IOVDD = 1.8 V	Normal (default)	9.37	-86	-91
	Extreme power saving	7.40	-84.5	-87
	Power saving	7.78	-84.5	-87.5
	Enhanced performance	10.4	-86	-94.5

## DIGITAL FILTERS

Table 6.

Parameter	Test Conditions/Comments	Min	Typ	Max	Unit
ADC INPUT TO DAC OUTPUT PATH					
Pass-Band Ripple	DC to 20 kHz, $f_s = 192$ kHz			$\pm 0.02$	dB
Group Delay	$f_s = 192$ kHz		38		$\mu$ s
SAMPLE RATE CONVERTER					
Pass Band	LRCLK < 63 kHz	0		$0.475 \times f_s$	kHz
	63 kHz < LRCLK < 130 kHz	0		$0.4286 \times f_s$	
	LRCLK > 130 kHz	0		$0.4286 \times f_s$	
Pass-Band Ripple	Upsampling, 96 kHz	-0.27		0.05	dB
	Upsampling, 192 kHz	-0.06		0.05	dB
	Downsampling, 96 kHz	0		0.07	dB
	Downsampling, 192 kHz	0		0.07	dB
Input/Output Frequency Range		8		192	kHz
Dynamic Range			100		dB
Total Harmonic Distortion + Noise			-90		dB
Startup Time				15	ms
PDM MODULATOR					
Dynamic Range (A-Weighted)			112		dB
Total Harmonic Distortion + Noise			-92		dB

**DIGITAL TIMING SPECIFICATIONS**

-40°C < T<sub>A</sub> < +85°C, IOVDD = 1.71 V to 3.63 V, DVDD = 1.045 V to 1.98 V.

**Table 7. Digital Timing**

Parameter	Limit		Unit	Description
	T <sub>MIN</sub>	T <sub>MAX</sub>		
<b>MASTER CLOCK</b>				
t <sub>MP</sub>	37	125	ns	MCLKIN period; 8 MHz to 27 MHz input clock using PLL
t <sub>MCLK</sub>	77	82	ns	Internal MCLK period; direct MCLK and PLL output divided by 2
<b>SERIAL PORT</b>				
t <sub>BL</sub>	40		ns	BCLK low pulse width (master and slave modes)
t <sub>BH</sub>	40		ns	BCLK high pulse width (master and slave modes)
t <sub>LS</sub>	10		ns	LRCLK setup; time to BCLK rising (slave mode)
t <sub>LH</sub>	10		ns	LRCLK hold; time from BCLK rising (slave mode)
t <sub>SS</sub>	5		ns	DAC_SDATA setup; time to BCLK rising (master and slave modes)
t <sub>SH</sub>	5		ns	DAC_SDATA hold; time from BCLK rising (master and slave modes)
t <sub>TS</sub>		10	ns	BCLK falling to LRCLK timing skew (master mode)
t <sub>SOD</sub>	0	34	ns	ADC_SDATAx delay; time from BCLK falling (master and slave modes)
t <sub>SOTD</sub>		30	ns	BCLK falling to ADC_SDATAx driven in TDM tristate mode
t <sub>SOTX</sub>		30	ns	BCLK falling to ADC_SDATAx tristated in TDM tristate mode
<b>SPI PORT</b>				
f <sub>SCLK</sub>		6.25	MHz	SCLK frequency
t <sub>CCPL</sub>	80		ns	SCLK pulse width low
t <sub>CCPH</sub>	80		ns	SCLK pulse width high
t <sub>CLS</sub>	5		ns	SS setup; time to SCLK rising
t <sub>CLH</sub>	100		ns	SS hold; time from SCLK rising
t <sub>CLPH</sub>	80		ns	SS pulse width high
t <sub>CDS</sub>	10		ns	MOSI setup; time to SCLK rising
t <sub>CDH</sub>	10		ns	MOSI hold; time from SCLK rising
t <sub>COD</sub>		101	ns	MISO delay; time from SCLK falling
<b>I<sup>2</sup>C PORT</b>				
f <sub>SCL</sub>		400	kHz	SCL frequency
t <sub>SCLH</sub>	0.6		μs	SCL high
t <sub>SCLL</sub>	1.3		μs	SCL low
t <sub>SCS</sub>	0.6		μs	SCL rise setup time (to SDA falling), relevant for repeated start condition
t <sub>SCR</sub>		250	ns	SCL and SDA rise time, C <sub>LOAD</sub> = 400 pF
t <sub>SCH</sub>	0.6		μs	SCL fall hold time (from SDA falling), relevant for start condition
t <sub>DS</sub>	100		ns	SDA setup time (to SCL rising)
t <sub>SCF</sub>		250	ns	SCL fall time; C <sub>LOAD</sub> = 400 pF
t <sub>SDF</sub>		250	ns	SDA fall time; C <sub>LOAD</sub> = 400 pF
t <sub>BFT</sub>	0.6		μs	SCL rise setup time (to SDA rising), relevant for stop condition
<b>I<sup>2</sup>C EEPROM SELF-BOOT</b>				
t <sub>SCHE</sub>	26 × t <sub>MP</sub> - 70		ns	SCL fall hold time (from SDA falling), relevant for start condition; t <sub>MP</sub> is the input clock on the MCLKIN pin
t <sub>SCSE</sub>	38 × t <sub>MP</sub> - 70		ns	SCL rise setup time (to SDA falling), relevant for repeated start condition
t <sub>BFTE</sub>	70 × t <sub>MP</sub> - 70		ns	SCL rise setup time (to SDA rising), relevant for stop condition
t <sub>DSE</sub>	6 × t <sub>MP</sub> - 70		ns	Delay from SCL falling to SDA changing
t <sub>BHTE</sub>	32 × t <sub>MP</sub>		ns	SDA rising in self-boot stop condition to SDA falling edge for external master start condition
<b>MULTIPURPOSE AND POWER-DOWN PINS</b>				
t <sub>GIL</sub>		1.5 × 1/f <sub>S</sub>	μs	MPx input latency; time until high or low value is read by core
t <sub>RLPW</sub>	20		ns	PD low pulse width

Parameter	Limit		Unit	Description
	T <sub>MIN</sub>	T <sub>MAX</sub>		
<b>DIGITAL MICROPHONE</b>				
t <sub>CF</sub>		20	ns	Digital microphone clock fall time
t <sub>CR</sub>		20	ns	Digital microphone clock rise time
t <sub>DS</sub>	40			Digital microphone valid data start time
t <sub>DE</sub>		0	ns	Digital microphone valid data end time
<b>PDM OUTPUT</b>				
t <sub>DCF</sub>		20	ns	PDM clock fall time
t <sub>DCR</sub>		20	ns	PDM clock rise time
t <sub>DDV</sub>	0	30	ns	PDM delay time for valid data

**Digital Timing Diagrams**

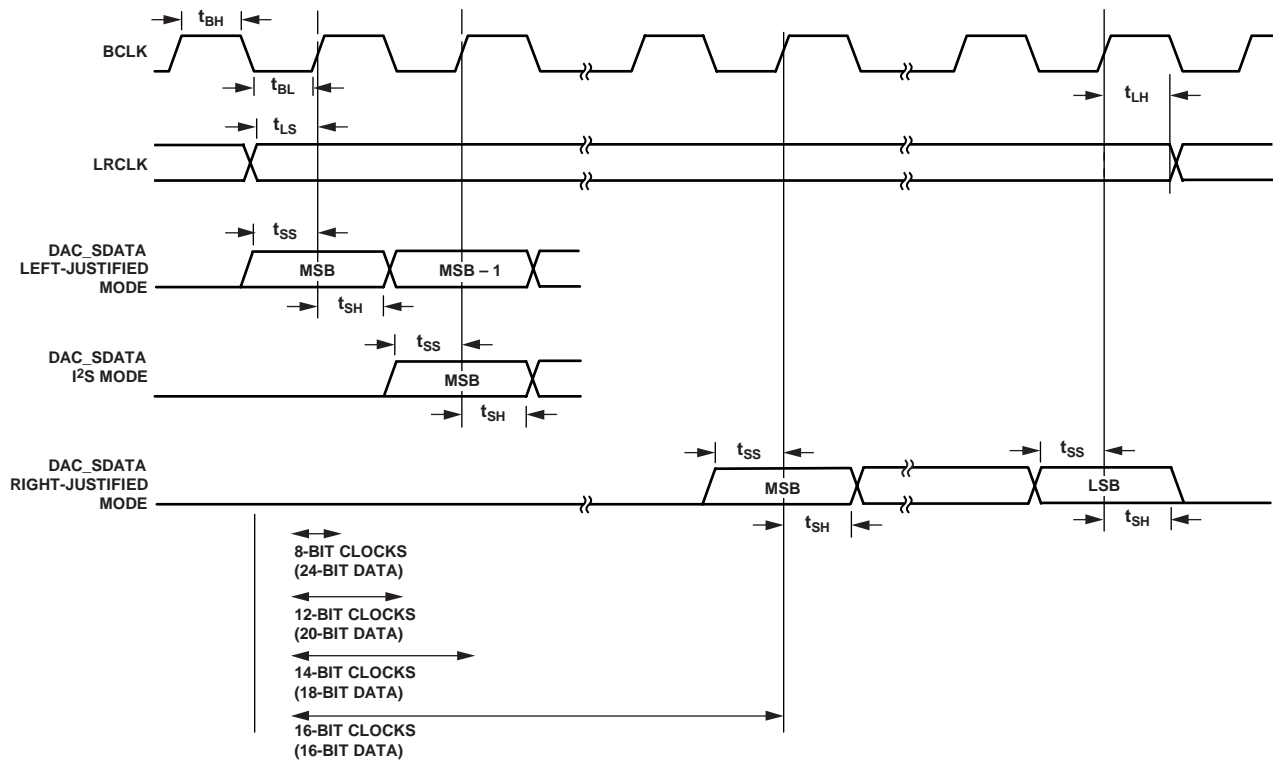

Figure 2. Serial Input Port Timing

10804-002

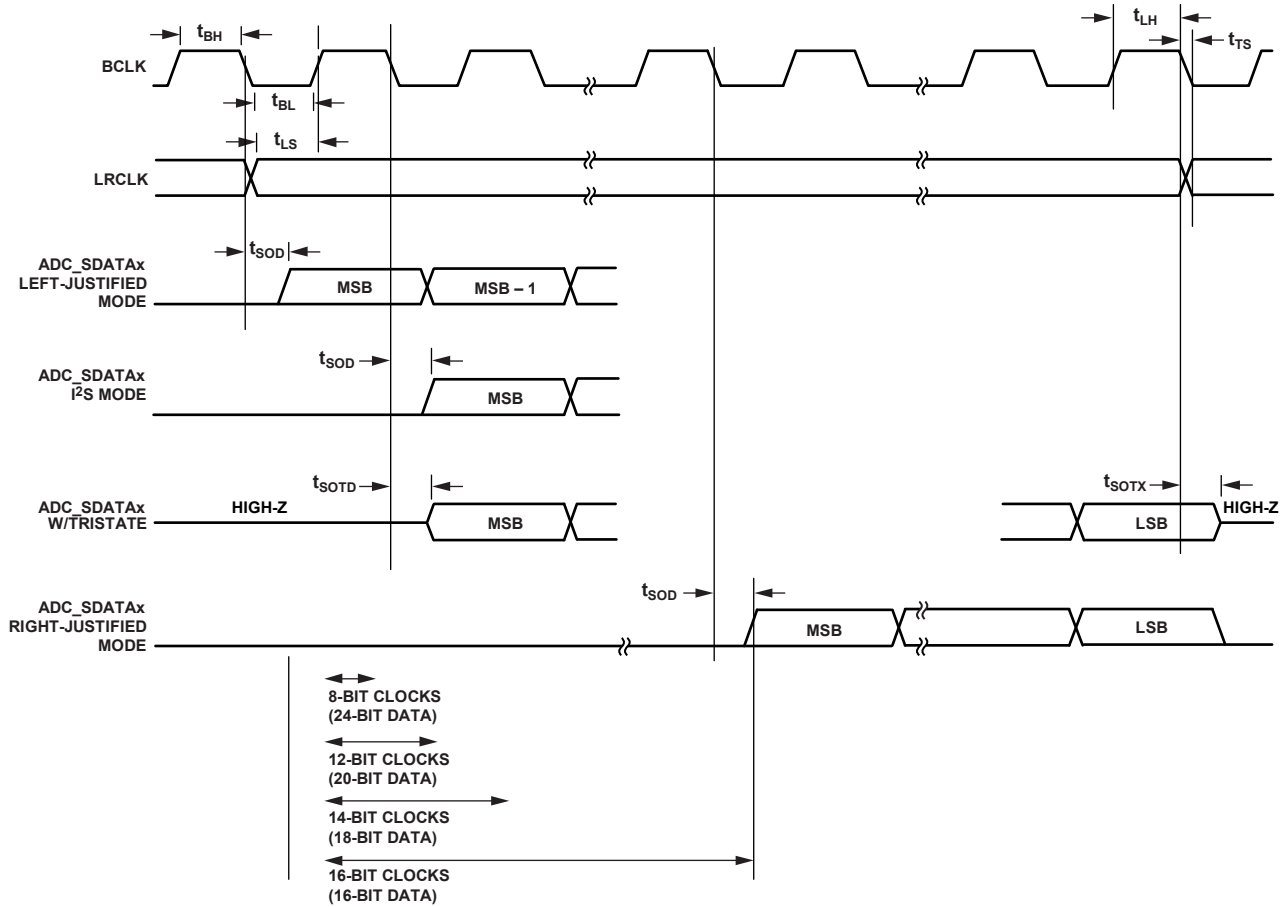

Figure 3. Serial Output Port Timing

10804-003

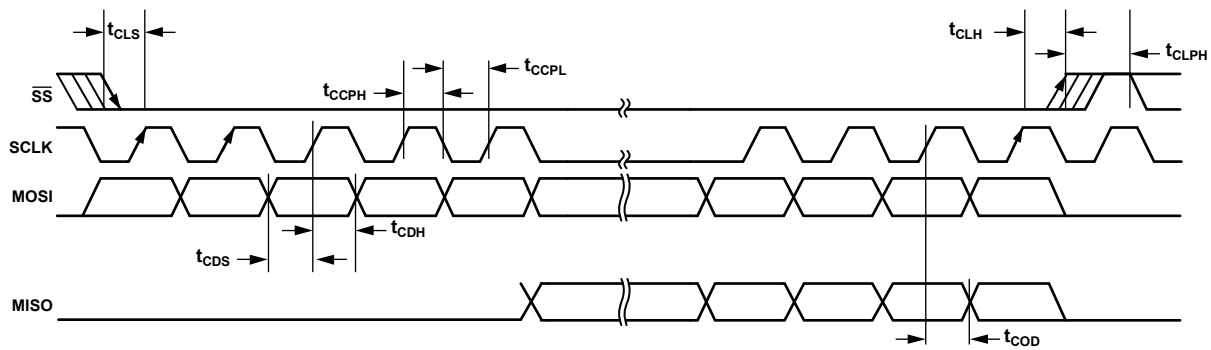

Figure 4. SPI Port Timing

10804-004

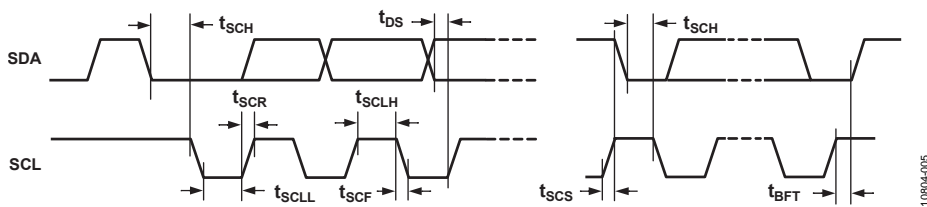

Figure 5. I<sup>2</sup>C Port Timing

10804-005

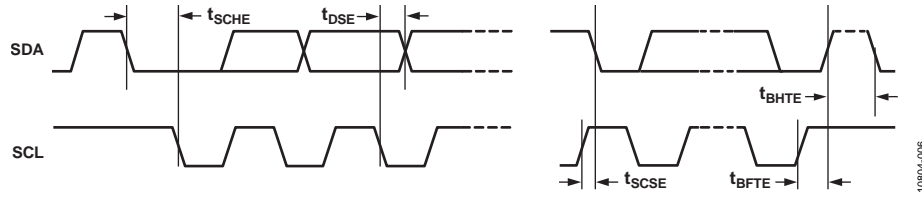

Figure 6. I<sup>2</sup>C Self-Boot Timing

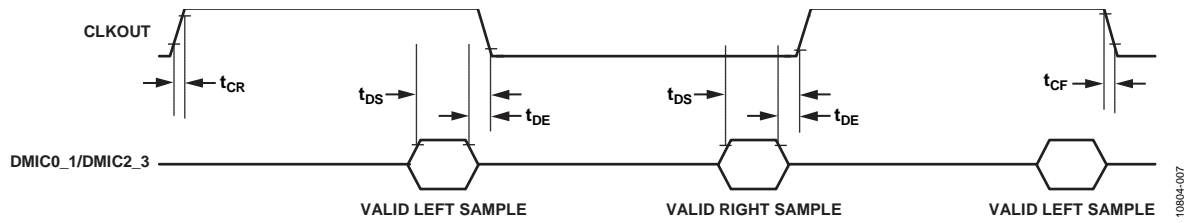

Figure 7. Digital Microphone Timing

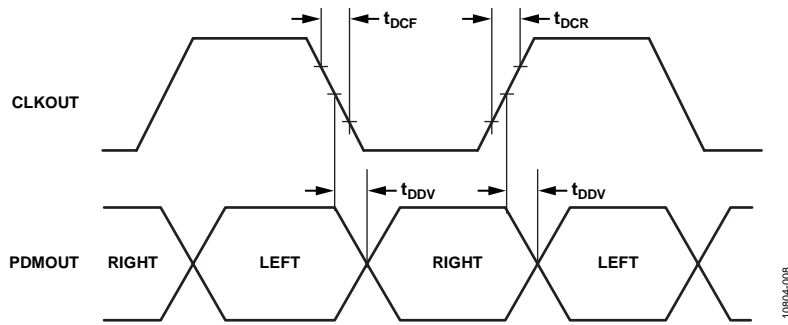

Figure 8. PDM Output Timing

## ABSOLUTE MAXIMUM RATINGS

Table 8.

Parameter	Rating
Power Supply (AVDD, IOVDD)	-0.3 V to +3.63 V
Digital Supply (DVDD)	-0.3 V to +1.98 V
Input Current (Except Supply Pins)	±20 mA
Analog Input Voltage (Signal Pins)	-0.3 V to AVDD + 0.3 V
Digital Input Voltage (Signal Pins)	-0.3 to IOVDD + 0.3 V
Operating Temperature Range (Case)	-40°C to +85°C
Storage Temperature Range	-65°C to +150°C

Stresses above those listed under Absolute Maximum Ratings may cause permanent damage to the device. This is a stress rating only; functional operation of the device at these or any other conditions above those indicated in the operational section of this specification is not implied. Exposure to absolute maximum rating conditions for extended periods may affect device reliability.

## THERMAL RESISTANCE

$\theta_{JA}$  represents the junction-to-ambient thermal resistance;  $\theta_{JC}$  represents the junction-to-case thermal resistance. Thermal numbers are simulated on a 4-layer JEDEC PCB with the exposed pad soldered to the PCB.  $\theta_{JC}$  was simulated at the exposed pad on the bottom of the package.

Table 9. Thermal Resistance

Package Type	$\theta_{JA}$	$\theta_{JC}$	Unit
40-Lead LFCSP	29	1.8	°C/W

## ESD CAUTION



**ESD (electrostatic discharge) sensitive device.** Charged devices and circuit boards can discharge without detection. Although this product features patented or proprietary protection circuitry, damage may occur on devices subjected to high energy ESD. Therefore, proper ESD precautions should be taken to avoid performance degradation or loss of functionality.

# PIN CONFIGURATION AND FUNCTION DESCRIPTIONS

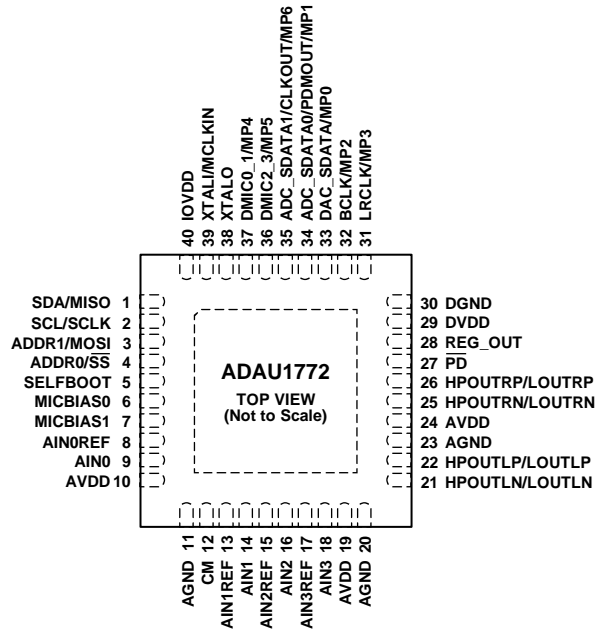

**NOTES**  
 1. THE EXPOSED PAD IS CONNECTED INTERNALLY TO THE ADAU1772 GROUNDS. FOR INCREASED RELIABILITY OF THE SOLDER JOINTS AND MAXIMUM THERMAL CAPABILITY, IT IS RECOMMENDED THAT THE PAD BE SOLDERED TO THE GROUND PLANE. SEE THE EXPOSED PAD PCB DESIGN SECTION FOR MORE INFORMATION.

10804-059

Figure 9. Pin Configuration

Table 10. Pin Function Descriptions

Pin No.	Mnemonic	Type <sup>1</sup>	Description
1	SDA/MISO	D_IO	I <sup>2</sup> C Data (SDA). This pin is a bidirectional open-collector. The line connected to this pin should have a 2.0 kΩ pull-up resistor. SPI Data Output (MISO). This SPI data output is used for reading back registers and memory locations. It is tristated when an SPI read is not active.
2	SCL/SCLK	D_IN	I <sup>2</sup> C Clock (SCL). This pin is always an open-collector input when the device is in I <sup>2</sup> C control mode. When the device is in self-boot mode, this pin is an open-collector output (I <sup>2</sup> C master). The line connected to this pin should have a 2.0 kΩ pull-up resistor.
3	ADDR1/MOSI	D_IN	SPI Clock (SCLK). This pin can either run continuously or be gated off between SPI transactions. I <sup>2</sup> C Address 1 (ADDR1).
4	ADDR0/ $\overline{SS}$	D_IN	SPI Data Input (MOSI). I <sup>2</sup> C Address 0 (ADDR0).
5	SELFBOOT	D_IN	SPI Latch Signal ( $\overline{SS}$ ). This pin must go low at the beginning of an SPI transaction and high at the end of a transaction. Each SPI transaction can take a different number of SCLK cycles to complete, depending on the address and read/write bit that are sent at the beginning of the SPI transaction.
6	MICBIAS0	A_OUT	Self-Boot. Pull this pin up to IOVDD at power-up to enable the self-boot mode.
7	MICBIAS1	A_OUT	Bias Voltage for Electret Microphone. Decouple with a 1 μF capacitor.
8	AIN0REF	A_IN	Bias Voltage for Electret Microphone. Decouple with a 1 μF capacitor.
9	AIN0	A_IN	ADC0 Input Reference. This reference pin should be ac-coupled to ground with a 10 μF capacitor.
10	AVDD	PWR	ADC0 Input.
11	AGND	PWR	1.8 V to 3.3 V Analog Supply. This pin should be decoupled to AGND with a 0.1 μF capacitor.
12	CM	A_OUT	Analog Ground. The AGND and DGND pins can be tied directly together in a common ground plane. AGND should be decoupled to AVDD with a 0.1 μF capacitor.
			AVDD/2 V Common-Mode Reference. A 10 μF to 47 μF decoupling capacitor should be connected between this pin and ground to reduce crosstalk between the ADCs and DACs. The material of the capacitors is not critical. This pin can be used to bias external analog circuits, as long as they are not drawing current from CM (for example, the noninverting input of an op amp).

Pin No.	Mnemonic	Type <sup>1</sup>	Description
13	AIN1REF	A_IN	ADC1 Input Reference. This reference pin should be ac-coupled to ground with a 10 µF capacitor.
14	AIN1	A_IN	ADC1 Input.
15	AIN2REF	A_IN	ADC2 Input Reference. This reference pin should be ac-coupled to ground with a 10 µF capacitor.
16	AIN2	A_IN	ADC2 Input.
17	AIN3REF	A_IN	ADC3 Input Reference. This reference pin should be ac-coupled to ground with a 10 µF capacitor.
18	AIN3	A_IN	ADC3 Input.
19	AVDD	PWR	1.8 V to 3.3 V Analog Supply. This pin should be decoupled to AGND with a 0.1 µF capacitor.
20	AGND	PWR	Analog Ground.
21	HPOUTLN/LOUTLN	A_OUT	Left Headphone Inverted (HPOUTLN). Line Output Inverted (LOUTLN).
22	HPOUTLP/LOUTLP	A_OUT	Left Headphone Noninverted (HPOUTLP). Line Output Noninverted, Single-Ended Line Output (LOUTLP).
23	AGND	PWR	Headphone Amplifier Ground.
24	AVDD	PWR	Headphone Amplifier Power, 1.8 V to 3.3 V Analog Supply. This pin should be decoupled to AGND with a 0.1 µF capacitor. The PCB trace to this pin should be wider to supply the higher current necessary for driving the headphone outputs.
25	HPOUTRN/LOUTRN	A_OUT	Right Headphone Inverted (HPOUTRN). Line Output Inverted (LOUTRN).
26	HPOUTRP/LOUTRP	A_OUT	Right Headphone Noninverted (HPOUTRP). Line Output Noninverted, Single-Ended Line Output (LOUTRP).
27	$\overline{\text{PD}}$	D_IN	Active Low Power-Down. All digital and analog circuits are powered down. There is an internal pull-down resistor on this pin; therefore, the ADAU1772 is held in power-down mode if its input signal is floating while power is applied to the supply pins.
28	REG_OUT	A_OUT	Regulator Output Voltage. This pin should be connected to DVDD if the internal voltage regulator is being used to generate DVDD voltage.
29	DVDD	PWR	Digital Core Supply. The digital supply can be generated from an on-board regulator or supplied directly from an external supply. In each case, DVDD should be decoupled to DGND with a 0.1 µF capacitor.
30	DGND	PWR	Digital Ground. The AGND and DGND pins can be tied directly together in a common ground plane.
31	LRCLK/MP3	D_IO	Serial Data Port Frame Clock (LRCLK). General-Purpose Input (MP3).
32	BCLK/MP2	D_IO	Serial Data Port Bit Clock (BCLK). General-Purpose Input (MP2).
33	DAC_SDATA/MP0	D_IO	DAC Serial Input Data (DAC_SDATA). General-Purpose Input (MP0).
34	ADC_SDATA0/PDMOUT/MP1	D_IO	ADC Serial Data Output 0 (ADC_SDATA0). Stereo PDM Output to Drive a High Efficiency Class-D Amplifier (PDMOUT). General-Purpose Input (MP1).
35	ADC_SDATA1/CLKOUT/MP6	D_IO	Serial Data Output 1 (ADC_SDATA1). Master Clock Output/Clock for the Digital Microphone Input and PDM Output (CLKOUT). General-Purpose Input (MP6).
36	DMIC2_3/MP5	D_IN	Digital Microphone Stereo Input 2 and Digital Microphone Stereo Input 3 (DMIC2_3). General-Purpose Input (MP5).
37	DMIC0_1/MP4	D_IN	Digital Microphone Stereo Input 0 and Digital Microphone Stereo Input 1 (DMIC0_1). General-Purpose Input (MP4).
38	XTALO	A_OUT	Crystal Clock Output. This pin is the output of the crystal amplifier and should not be used to provide a clock to other ICs in the system. If a master clock output is needed, use CLKOUT (Pin 35).
39	XTALI/MCLKIN	D_IN	Crystal Clock Input (XTALI). Master Clock Input (MCLKIN)
40	IOVDD	PWR	Supply for Digital Input and Output Pins. The digital output pins are supplied from IOVDD, and this sets the highest input voltage that should be seen on the digital input pins. The current draw of this pin is variable because it is dependent on the loads of the digital outputs. IOVDD should be decoupled to DGND with a 0.1 µF capacitor.
	EP		Exposed Pad. The exposed pad is connected internally to the ADAU1772 grounds. For increased reliability of the solder joints and maximum thermal capability, it is recommended that the pad be soldered to the ground plane. See the Exposed Pad PCB Design section for more information.

<sup>1</sup> D\_IO = digital input/output, D\_IN = digital input, A\_OUT = analog output, A\_IN = analog input, PWR = power, A\_IN = analog input.

### TYPICAL PERFORMANCE CHARACTERISTICS

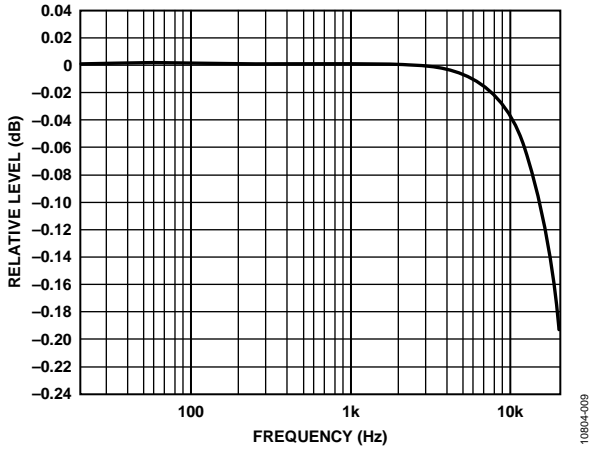

Figure 10. Relative Level vs. Frequency,  $f_s = 48$  kHz, Signal Path = AIN0 to DSP (Without Processing) to LOU TLx

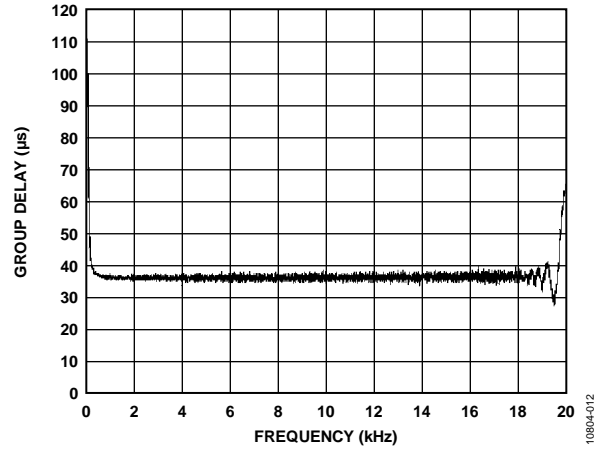

Figure 13. Group Delay vs. Frequency,  $f_s = 48$  kHz, Signal Path = AIN0 to DSP (Without Processing) to LOU TLx

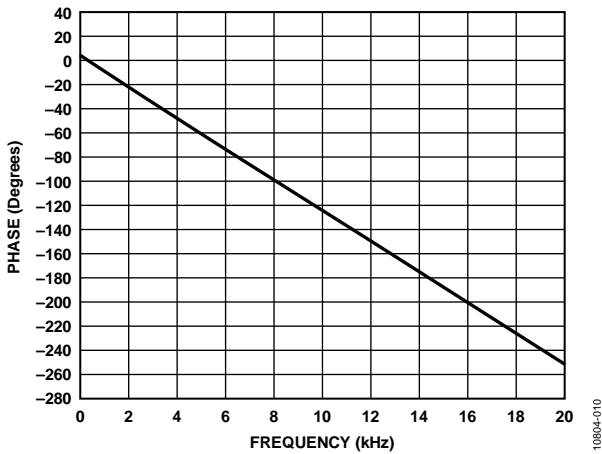

Figure 11. Phase vs. Frequency, 20 kHz Bandwidth,  $f_s = 48$  kHz, Signal Path = AIN0 to DSP (Without Processing) to LOU TLx

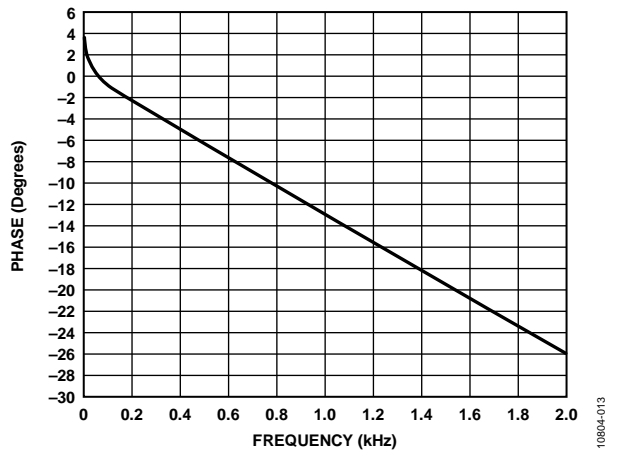

Figure 14. Phase vs. Frequency, 2 kHz Bandwidth,  $f_s = 48$  kHz, Signal Path = AIN0 to DSP (Without Processing) to LOU TLx

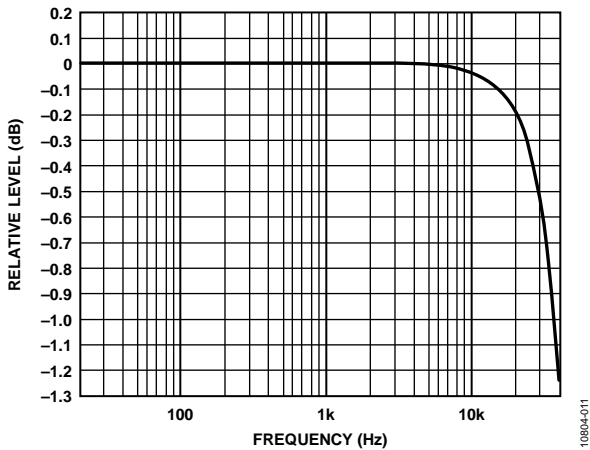

Figure 12. Relative Level vs. Frequency,  $f_s = 96$  kHz, Signal Path = AIN0 to DSP (Without Processing) to LOU TLx

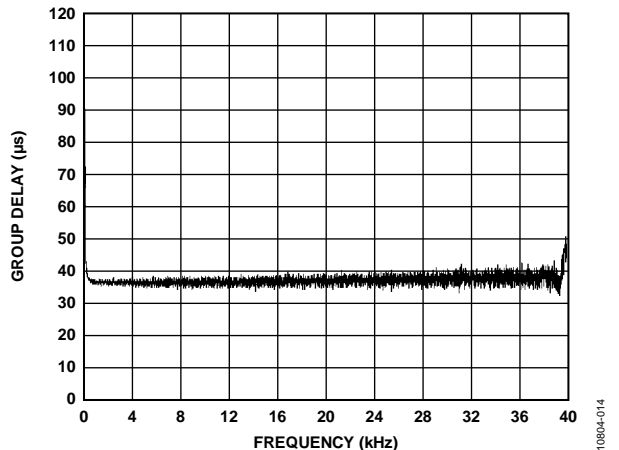

Figure 15. Group Delay vs. Frequency,  $f_s = 96$  kHz, Signal Path = AIN0 to DSP (Without Processing) to LOU TLx

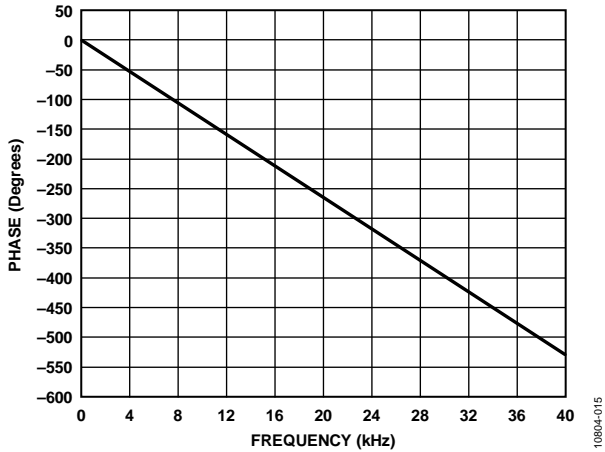

Figure 16. Phase vs. Frequency, 40 kHz Bandwidth,  $f_s = 96$  kHz, Signal Path = AIN0 to DSP (Without Processing) to LOU TLx

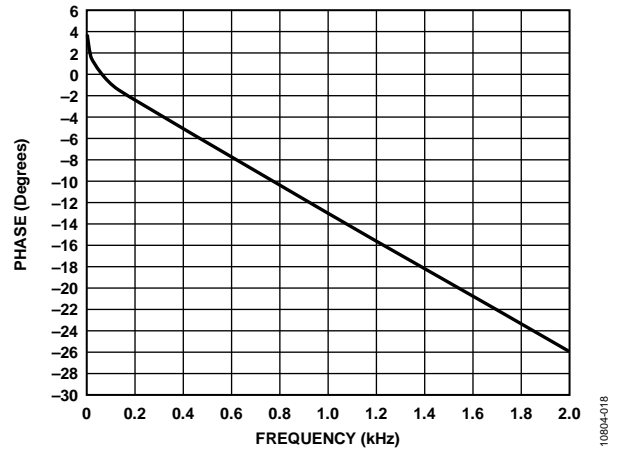

Figure 19. Phase vs. Frequency, 2 kHz Bandwidth,  $f_s = 96$  kHz, Signal Path = AIN0 to DSP (Without Processing) to LOU TLx

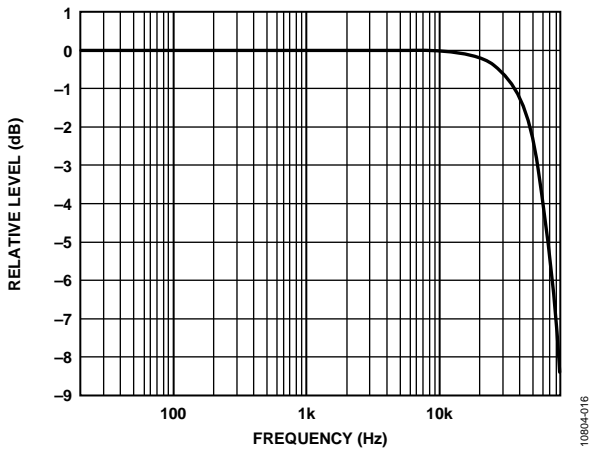

Figure 17. Relative Level vs. Frequency,  $f_s = 192$  kHz, Signal Path = AIN0 to DSP (Without Processing) to LOU TLx

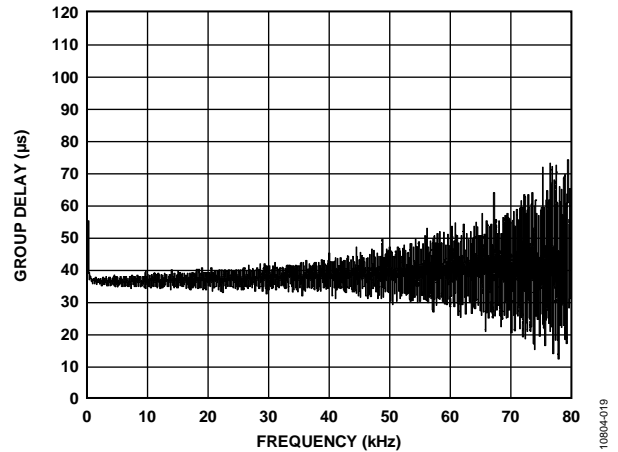

Figure 20. Group Delay vs. Frequency,  $f_s = 192$  kHz, Signal Path = AIN0 to DSP (Without Processing) to LOU TLx

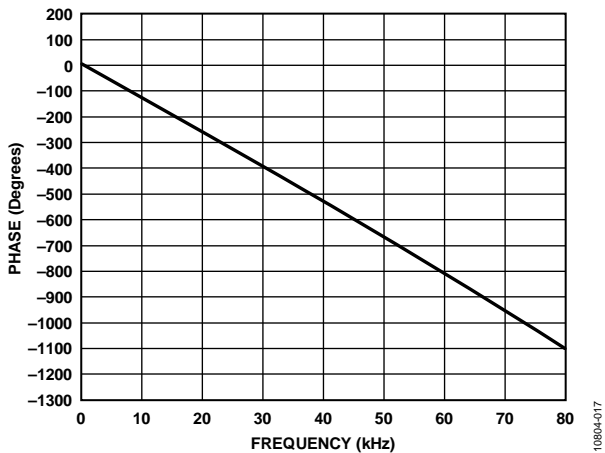

Figure 18. Phase vs. Frequency, 80 kHz Bandwidth,  $f_s = 192$  kHz, Signal Path = AIN0 to DSP (Without Processing) to LOU TLx

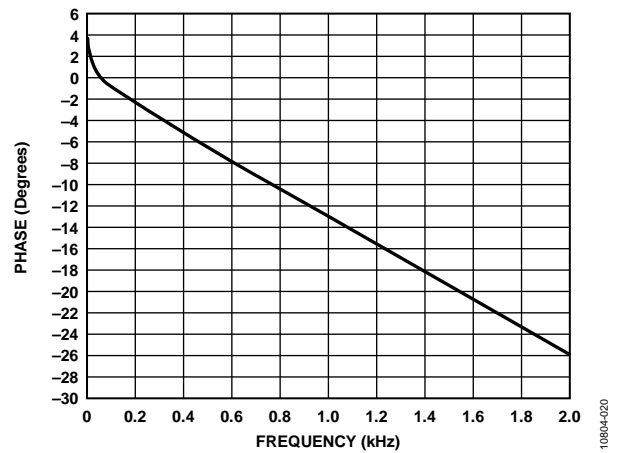

Figure 21. Phase vs. Frequency, 2 kHz Bandwidth,  $f_s = 192$  kHz, Signal Path = AIN0 to DSP (Without Processing) to LOU TLx

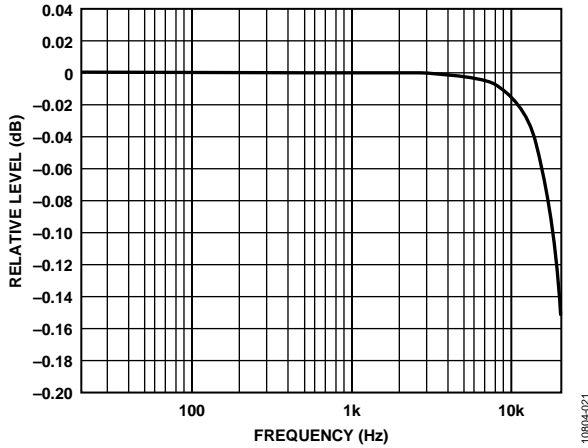

Figure 22. Relative Level vs. Frequency,  $f_s = 48$  kHz, Signal Path = AIN0 to ASRC to ADC\_SDATA0

10894-021

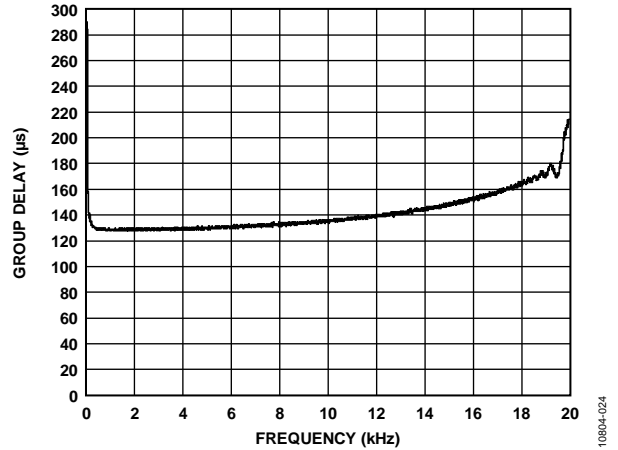

Figure 25. Group Delay vs. Frequency,  $f_s = 48$  kHz, Signal Path = AIN0 to ASRC to ADC\_SDATA0

10894-024

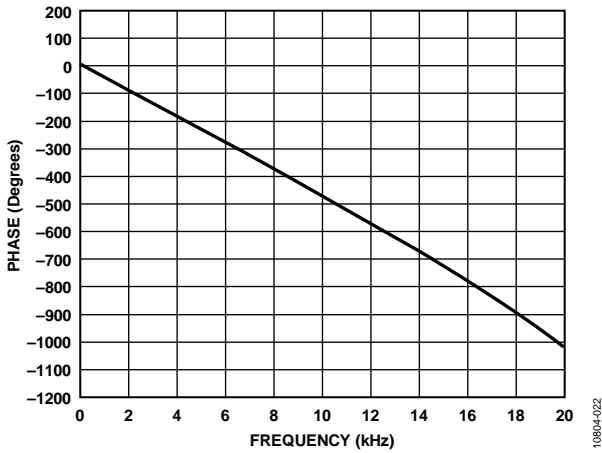

Figure 23. Phase vs. Frequency, 20 kHz Bandwidth,  $f_s = 48$  kHz, Signal Path = AIN0 to ASRC to ADC\_SDATA0

10894-022

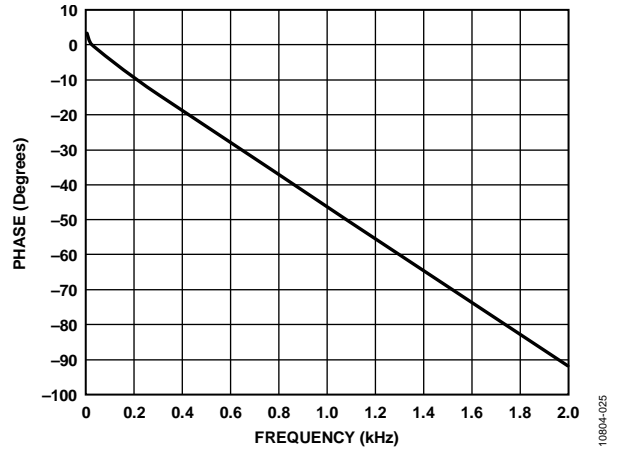

Figure 26. Phase vs. Frequency, 2 kHz Bandwidth,  $f_s = 48$  kHz, Signal Path = AIN0 to ASRC to ADC\_SDATA0

10894-025

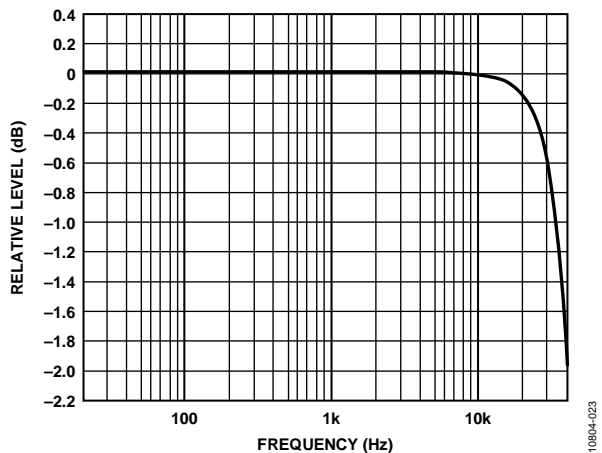

Figure 24. Relative Level vs. Frequency,  $f_s = 96$  kHz, Signal Path = AIN0 to ASRC to ADC\_SDATA0

10894-023

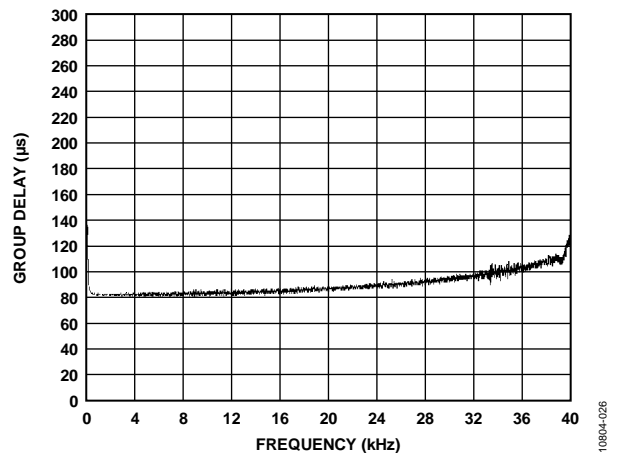

Figure 27. Group Delay vs. Frequency,  $f_s = 96$  kHz, Signal Path = AIN0 to ASRC to ADC\_SDATA0

10894-026

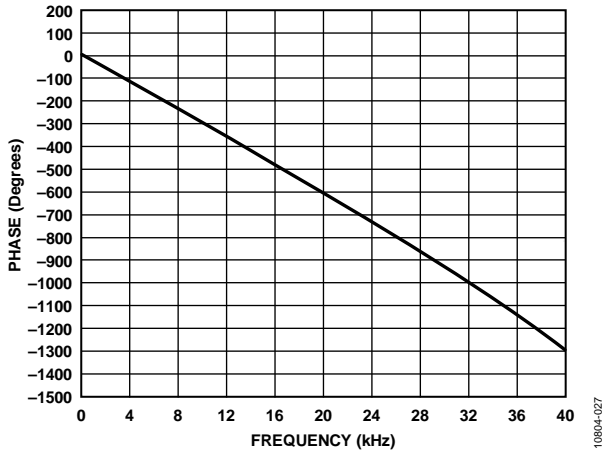

Figure 28. Phase vs. Frequency, 40 kHz Bandwidth,  $f_s = 96$  kHz, Signal Path = AIN0 to ASRC to ADC\_SDAT0A0

1080A-027

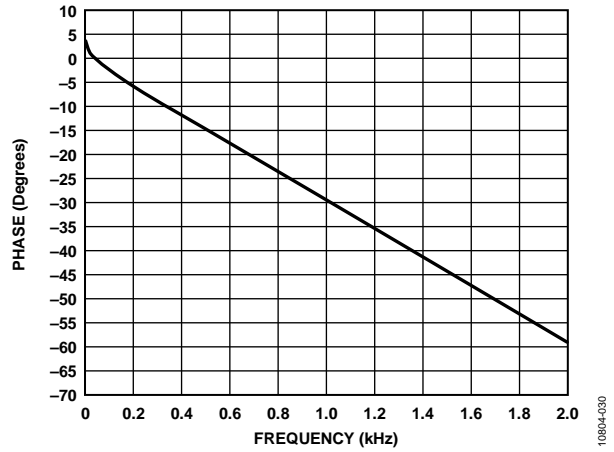

Figure 31. Phase vs. Frequency, 2 kHz Bandwidth,  $f_s = 96$  kHz, Signal Path = AIN0 to ASRC to ADC\_SDAT0A0

1080A-030

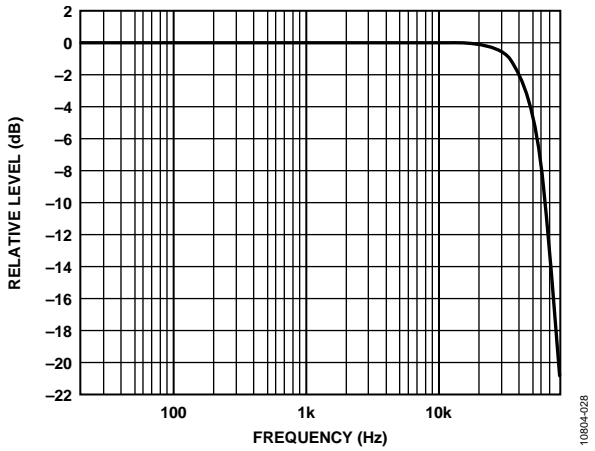

Figure 29. Relative Level vs. Frequency,  $f_s = 192$  kHz, Signal Path = AIN0 to ASRC to ADC\_SDAT0A0

1080A-028

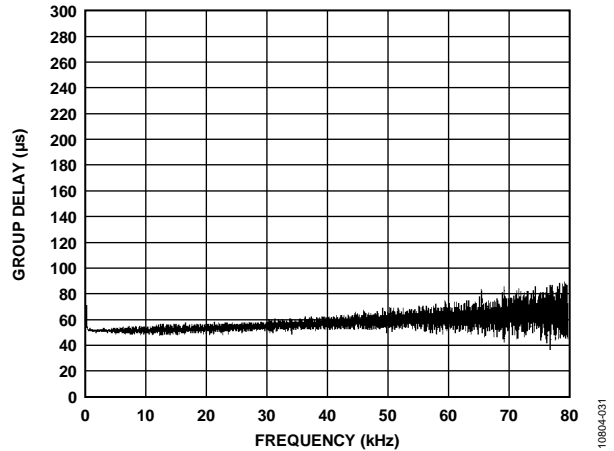

Figure 32. Group Delay vs. Frequency,  $f_s = 192$  kHz, Signal Path = AIN0 to ASRC to ADC\_SDAT0A0

1080A-031

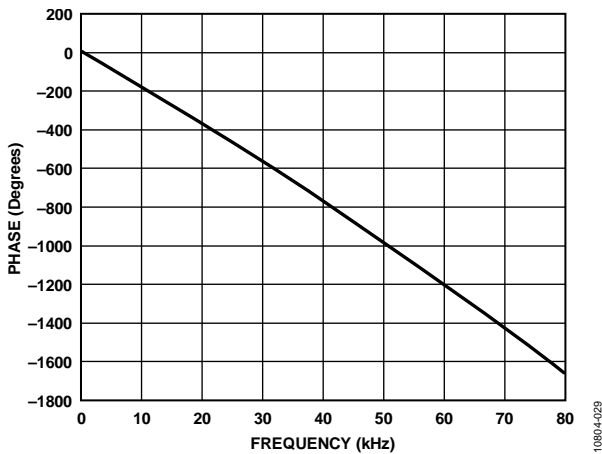

Figure 30. Phase vs. Frequency, 80 kHz Bandwidth,  $f_s = 192$  kHz, Signal Path = AIN0 to ASRC to ADC\_SDAT0A0

1080A-029

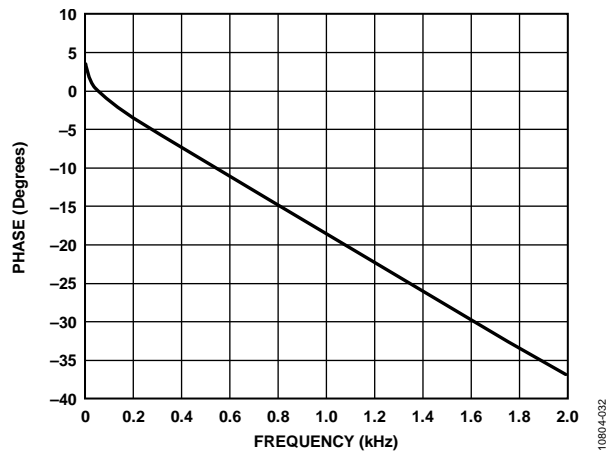

Figure 33. Phase vs. Frequency, 2 kHz Bandwidth,  $f_s = 192$  kHz, Signal Path = AIN0 to ASRC to ADC\_SDAT0A0

1080A-032

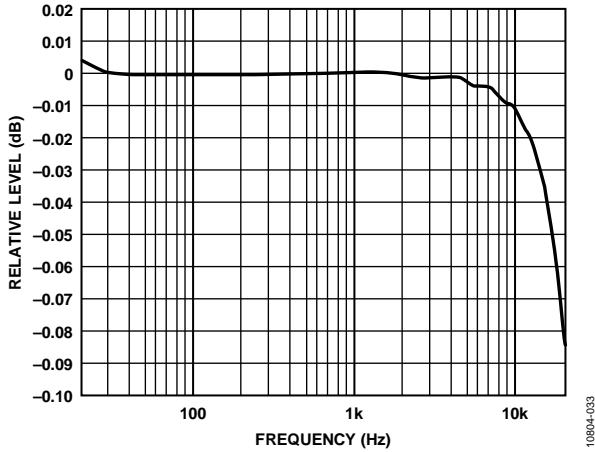

Figure 34. Relative Level vs. Frequency,  
 $f_s = 48$  kHz, Signal Path = DAC\_SDATA to ASRC to LOU TLx

10804-033

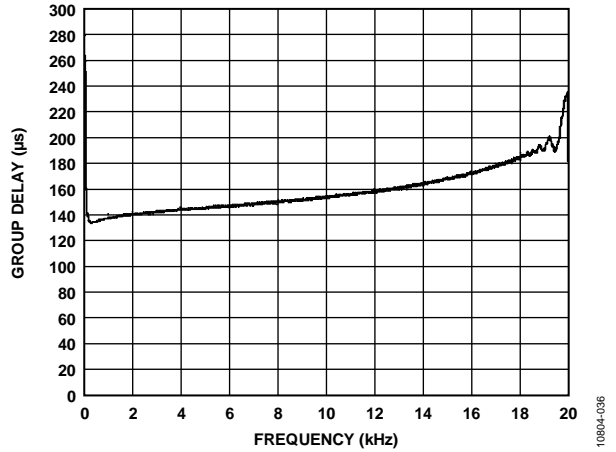

Figure 37. Group Delay vs. Frequency,  
 $f_s = 48$  kHz, Signal Path = DAC\_SDATA to ASRC to LOU TLx

10804-036

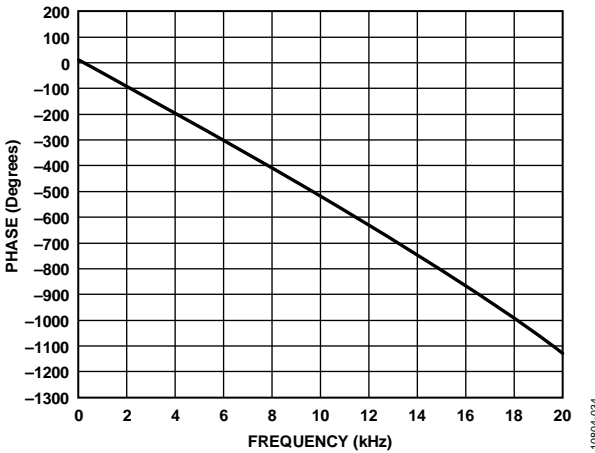

Figure 35. Phase vs. Frequency, 20 kHz Bandwidth,  
 $f_s = 48$  kHz, Signal Path = DAC\_SDATA to ASRC to LOU TLx

10804-034

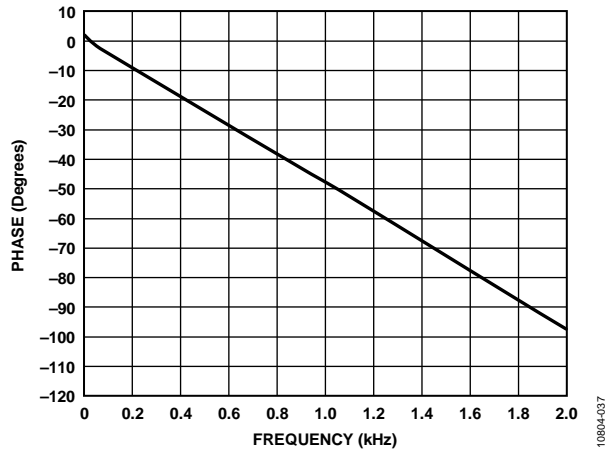

Figure 38. Phase vs. Frequency, 2 kHz Bandwidth,  
 $f_s = 48$  kHz, Signal Path = DAC\_SDATA to ASRC to LOU TLx

10804-037

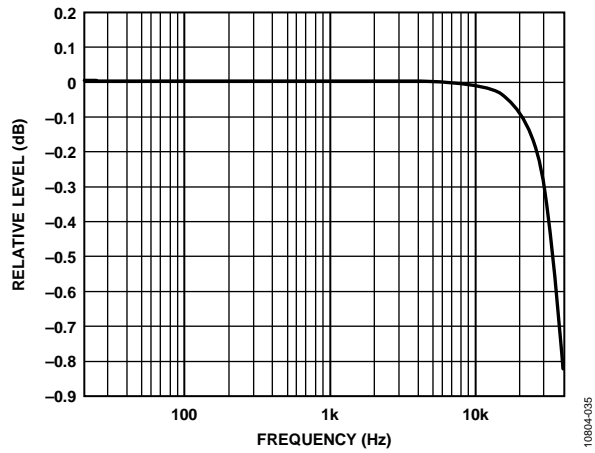

Figure 36. Relative Level vs. Frequency,  
 $f_s = 96$  kHz, Signal Path = DAC\_SDATA to ASRC to LOU TLx

10804-035

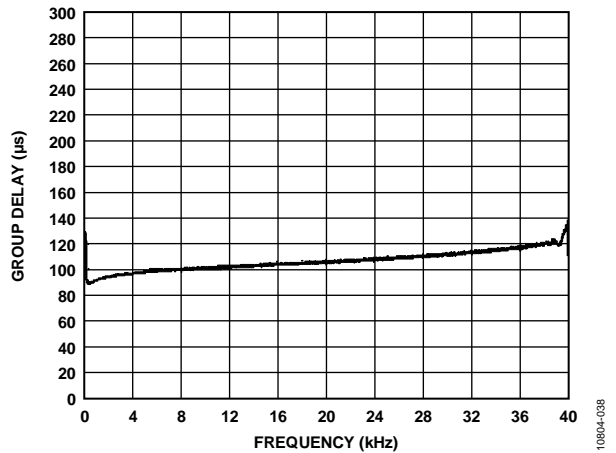

Figure 39. Group Delay vs. Frequency,  
 $f_s = 96$  kHz, Signal Path = DAC\_SDATA to ASRC to LOU TLx

10804-038

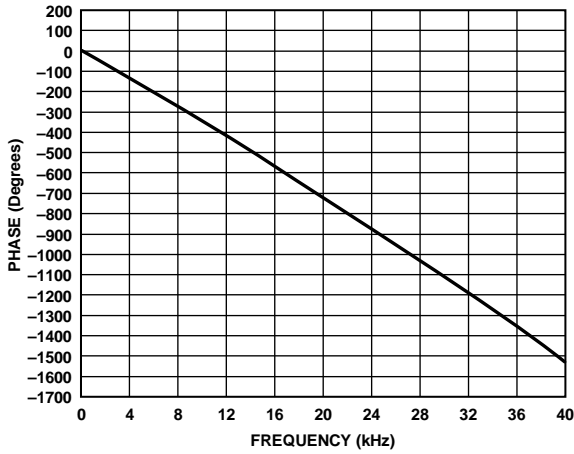

Figure 40. Phase vs. Frequency, 40 kHz Bandwidth,  $f_s = 96$  kHz, Signal Path = DAC\_SDATA to ASRC to LOU TLx

10804-039

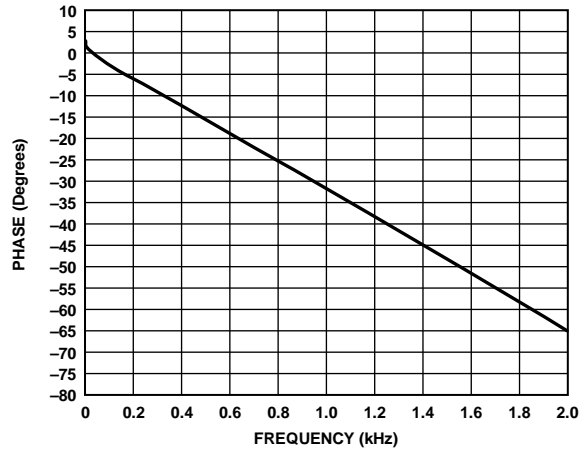

Figure 43. Phase vs. Frequency, 2 kHz Bandwidth,  $f_s = 96$  kHz, Signal Path = DAC\_SDATA to ASRC to LOU TLx

10804-042

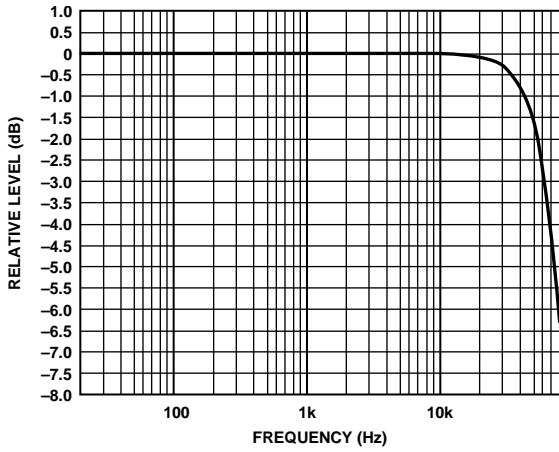

Figure 41. Relative Level vs. Frequency,  $f_s = 192$  kHz, Signal Path = DAC\_SDATA to ASRC to LOU TLx

10804-040

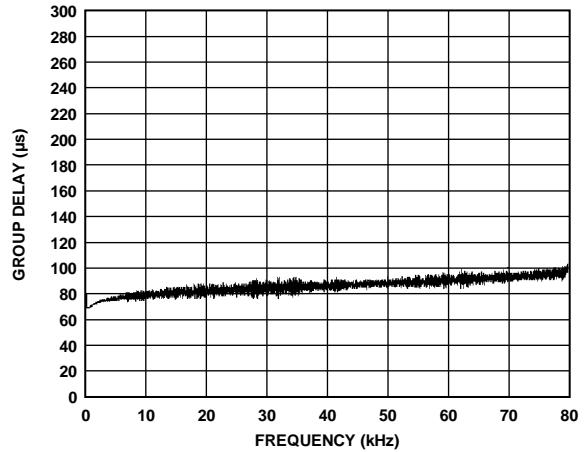

Figure 44. Group Delay vs. Frequency,  $f_s = 192$  kHz, Signal Path = DAC\_SDATA to ASRC to LOU TLx

10804-043

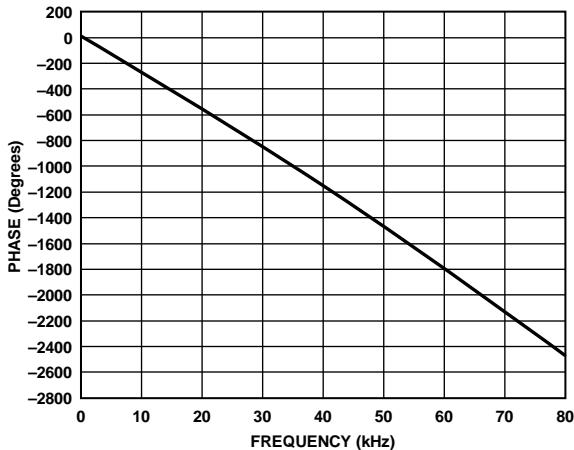

Figure 42. Phase vs. Frequency, 80 kHz Bandwidth,  $f_s = 192$  kHz, Signal Path = DAC\_SDATA to ASRC to LOU TLx

10804-041

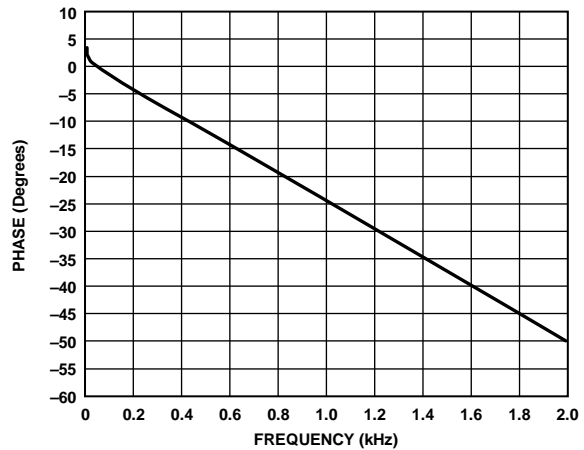

Figure 45. Phase vs. Frequency, 2 kHz Bandwidth,  $f_s = 192$  kHz, Signal Path = DAC\_SDATA to ASRC to LOU TLx

10804-044

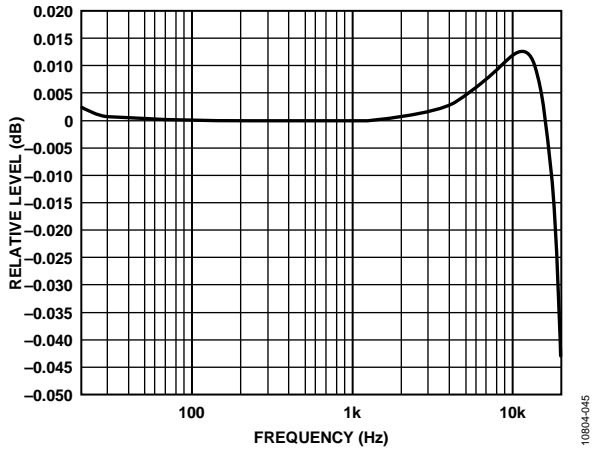

Figure 46. Relative Level vs. Frequency,  $f_s = 48$  kHz, Signal Path = DAC\_SDATA to ASRC to DSP (Without Processing) to ASRC to ADC\_SDATA0

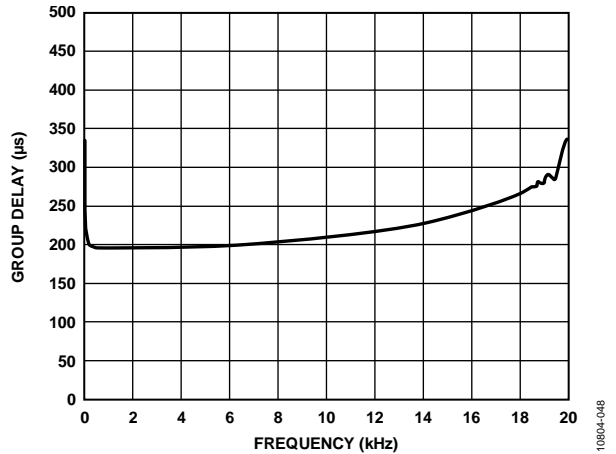

Figure 49. Group Delay vs. Frequency,  $f_s = 48$  kHz, Signal Path = DAC\_SDATA to ASRC to DSP (Without Processing) to ASRC to ADC\_SDATA0

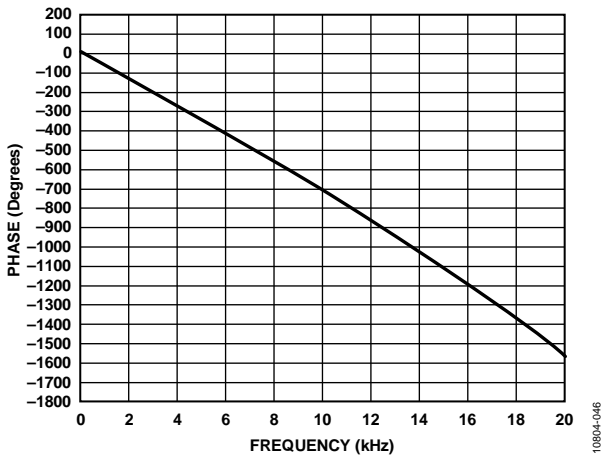

Figure 47. Phase vs. Frequency, 20 kHz Bandwidth,  $f_s = 48$  kHz, Signal Path = DAC\_SDATA to ASRC to DSP (Without Processing) to ASRC to ADC\_SDATA0

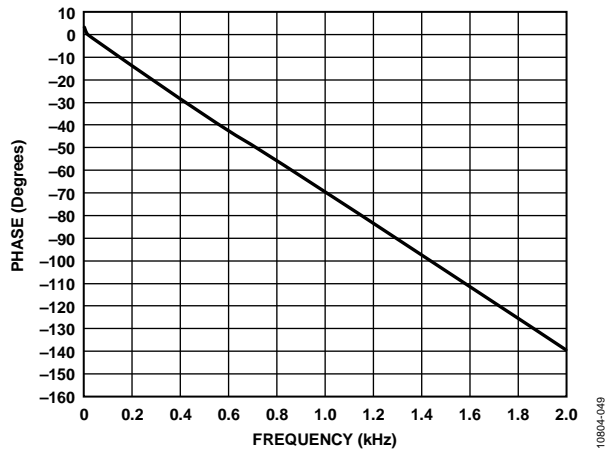

Figure 50. Phase vs. Frequency, 2 kHz Bandwidth,  $f_s = 48$  kHz, Signal Path = DAC\_SDATA to ASRC to DSP (Without Processing) to ASRC to ADC\_SDATA0

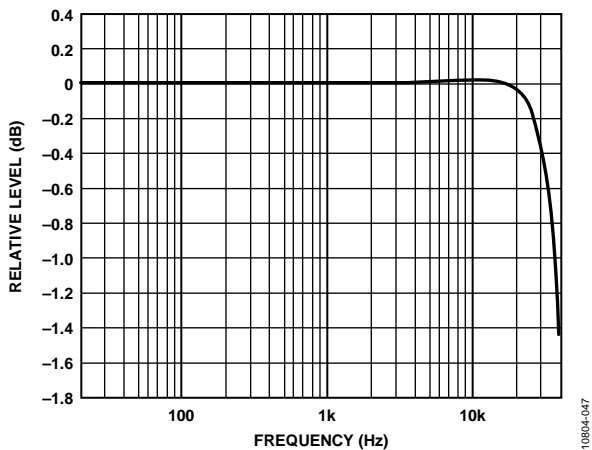

Figure 48. Relative Level vs. Frequency,  $f_s = 96$  kHz, Signal Path = DAC\_SDATA to ASRC to DSP (Without Processing) to ASRC to ADC\_SDATA0

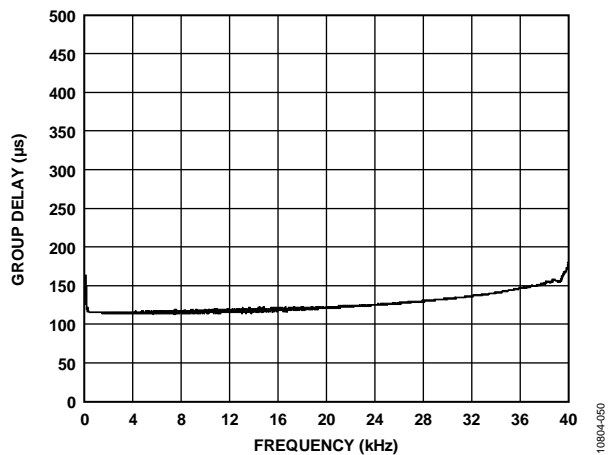
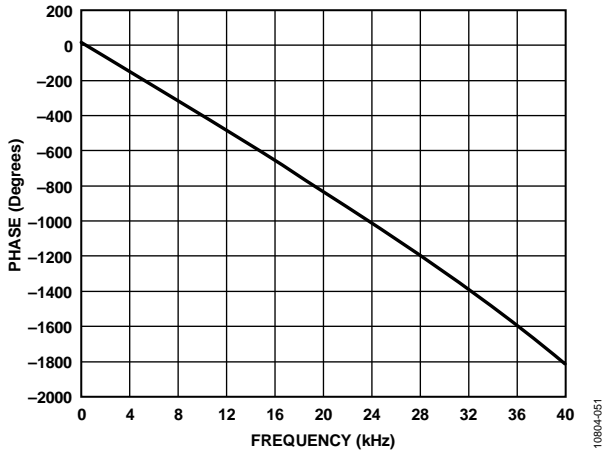
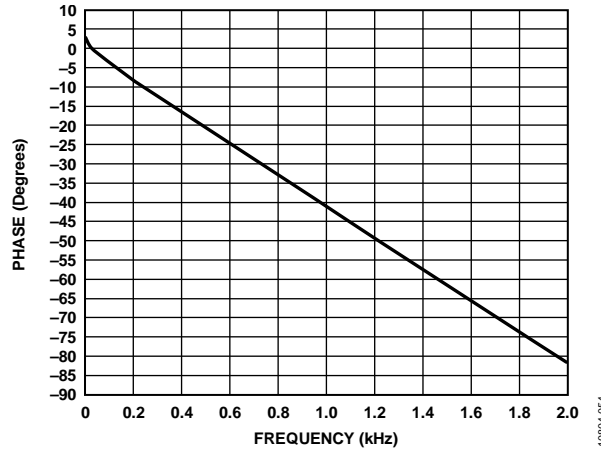

Figure 51. Group Delay vs. Frequency,  $f_s = 96$  kHz, Signal Path = DAC\_SDATA to ASRC to DSP (Without Processing) to ASRC to ADC\_SDATA0



1080A-051

Figure 52. Phase vs. Frequency, 40 kHz Bandwidth,  $f_s = 96$  kHz, Signal Path = DAC\_SDATA to ASRC to DSP (Without Processing) to ASRC to ADC\_SDATA0



1080A-054

Figure 55. Phase vs. Frequency, 2 kHz Bandwidth,  $f_s = 96$  kHz, Signal Path = DAC\_SDATA to ASRC to DSP (Without Processing) to ASRC to ADC\_SDATA0

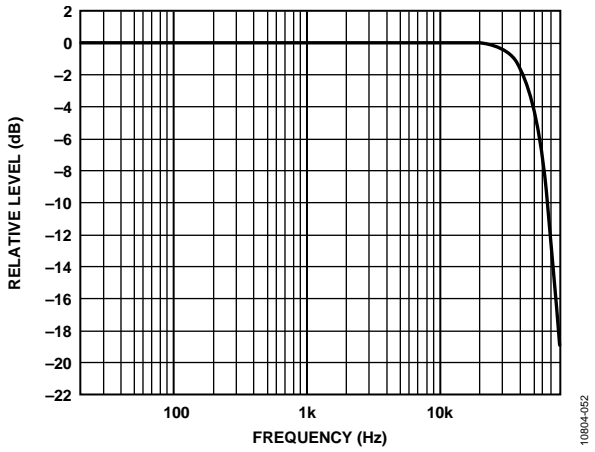

1080A-052

Figure 53. Relative Level vs. Frequency,  $f_s = 192$  kHz, Signal Path = DAC\_SDATA to ASRC to DSP (Without Processing) to ASRC to ADC\_SDATA0

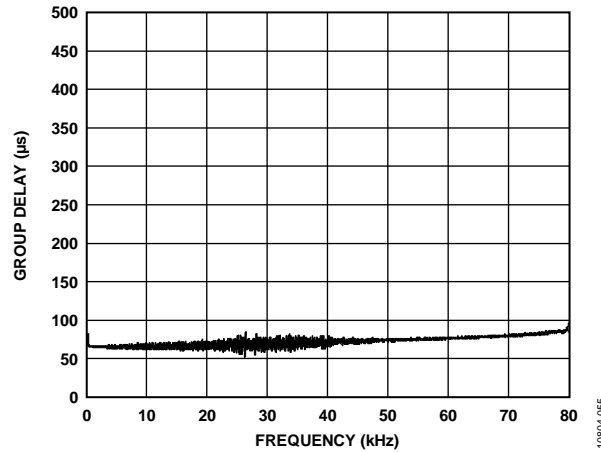

1080A-055

Figure 56. Group Delay vs. Frequency,  $f_s = 192$  kHz, Signal Path = DAC\_SDATA to ASRC to DSP (Without Processing) to ASRC to ADC\_SDATA0

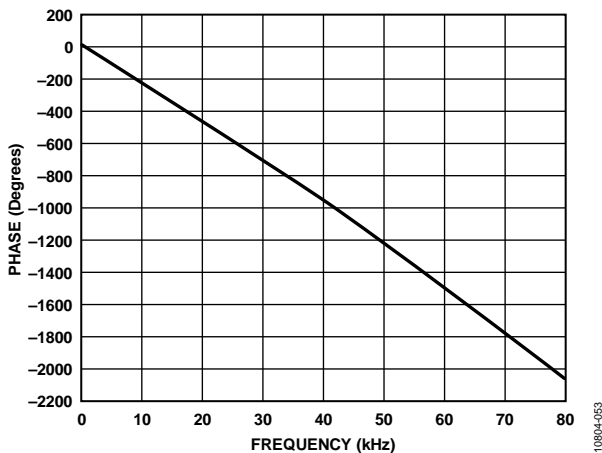

1080A-053

Figure 54. Phase vs. Frequency, 80 kHz Bandwidth,  $f_s = 192$  kHz, Signal Path = DAC\_SDATA to ASRC to DSP (Without Processing) to ASRC to ADC\_SDATA0

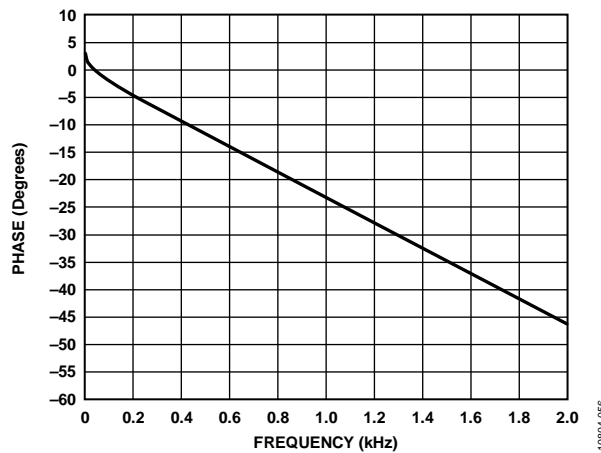

1080A-056

Figure 57. Phase vs. Frequency, 2 kHz Bandwidth,  $f_s = 192$  kHz, Signal Path = DAC\_SDATA to ASRC to DSP (Without Processing) to ASRC to ADC\_SDATA0

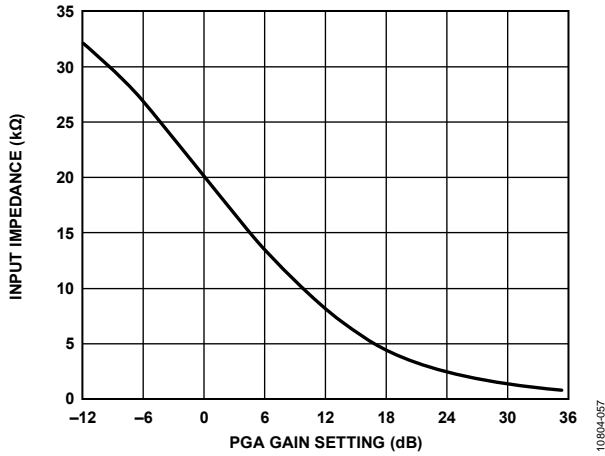

Figure 58. Input Impedance vs. PGA Gain (see the Input Impedance section)

10804-057

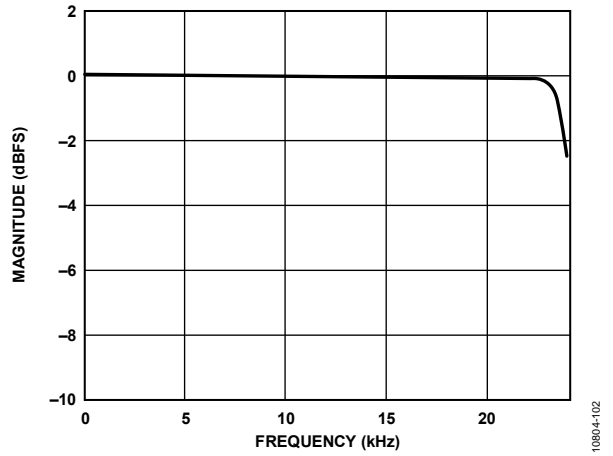

Figure 61. Decimation Pass-Band Response,  $f_s = 192$  kHz

10804-102

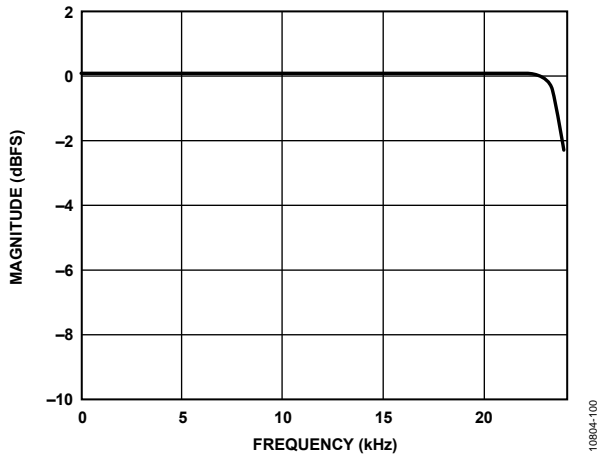

Figure 59. Decimation Pass-Band Response,  $f_s = 96$  kHz

10804-100

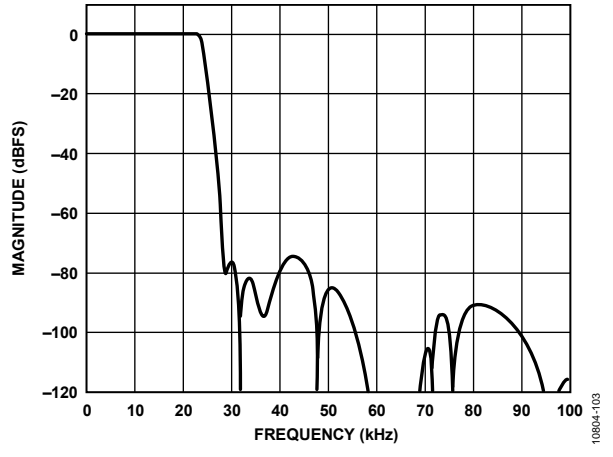

Figure 62. Total Decimation Response, Core  $f_s = 192$  kHz, Serial Port  $f_s = 48$  kHz

10804-103

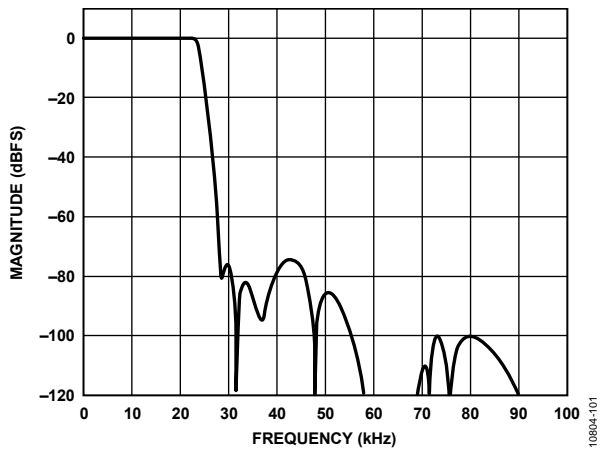

Figure 60. Total Decimation Response, Core  $f_s = 96$  kHz, Serial Port  $f_s = 48$  kHz

10804-101

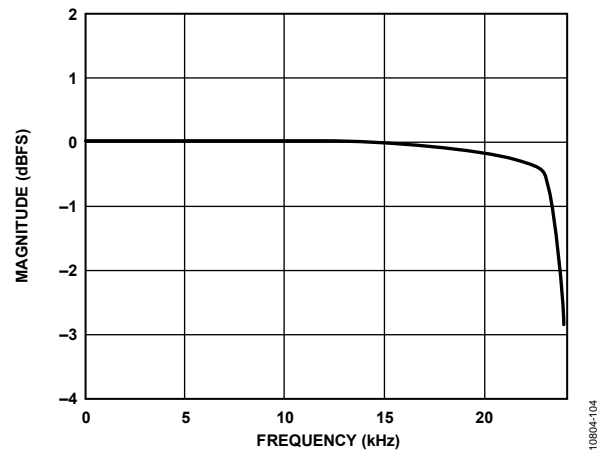

Figure 63. Interpolation Pass-Band Response,  $f_s = 96$  kHz

10804-104

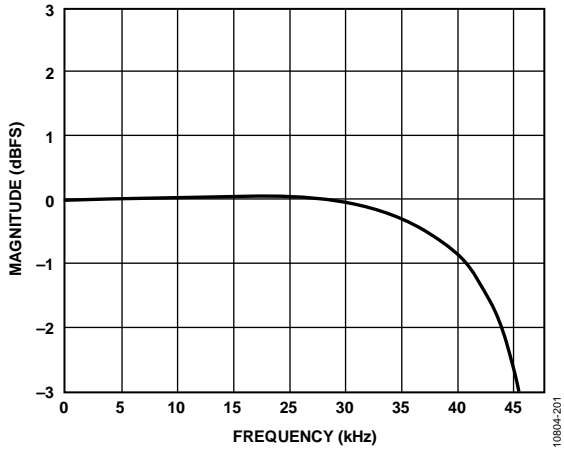

Figure 64. Decimation Pass-Band Response, Core  $f_s = 96$  kHz, Serial Port  $f_s = 96$  kHz

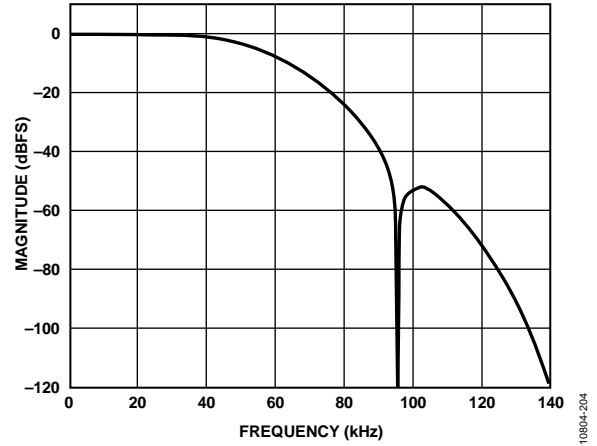

Figure 67. Total Decimation Response, Core  $f_s = 96$  kHz, Serial Port  $f_s = 192$  kHz

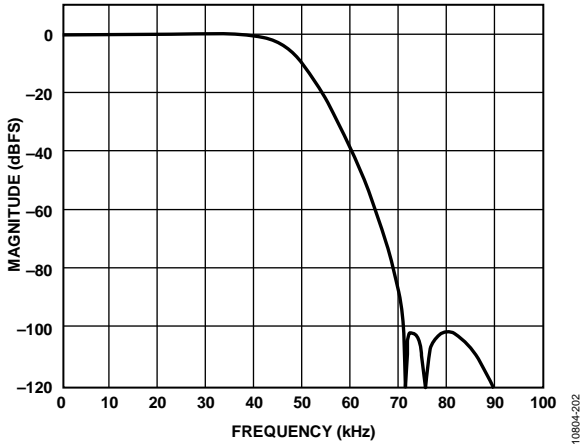

Figure 65. Total Decimation Response, Core  $f_s = 96$  kHz, Serial Port  $f_s = 96$  kHz

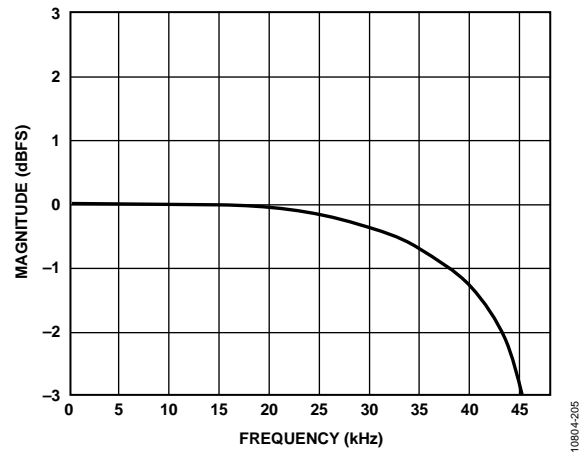

Figure 68. Decimation Pass-Band Response, Core  $f_s = 192$  kHz, Serial Port  $f_s = 96$  kHz

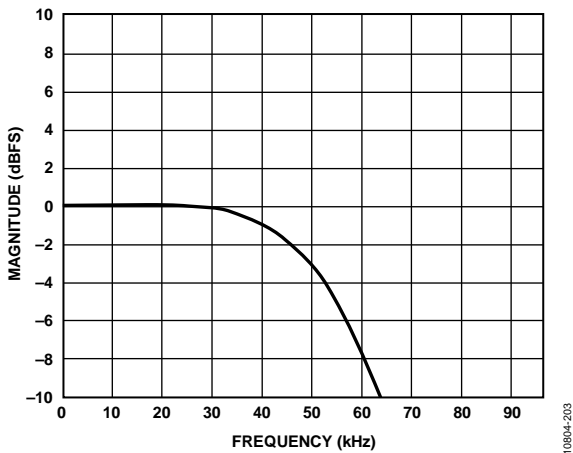

Figure 66. Decimation Pass-Band Response, Core  $f_s = 96$  kHz, Serial Port  $f_s = 192$  kHz

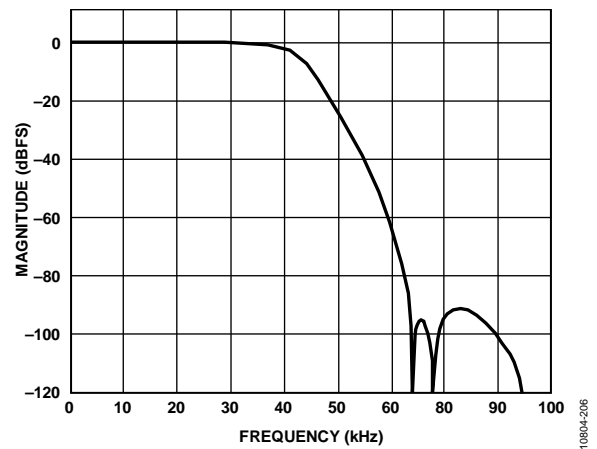

Figure 69. Total Decimation Response, Core  $f_s = 192$  kHz, Serial Port  $f_s = 96$  kHz

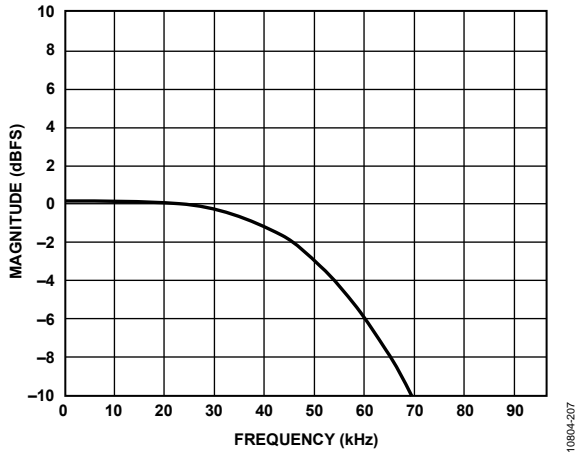

Figure 70. Decimation Pass-Band Response, Core  $f_s = 192$  kHz, Serial Port  $f_s = 192$  kHz

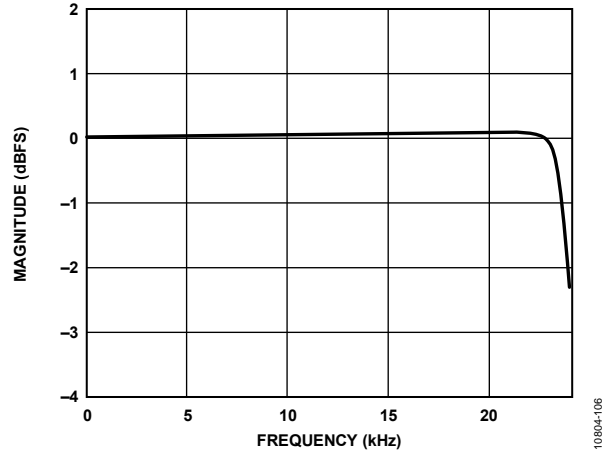

Figure 73. Interpolation Pass-Band Response,  $f_s = 192$  kHz

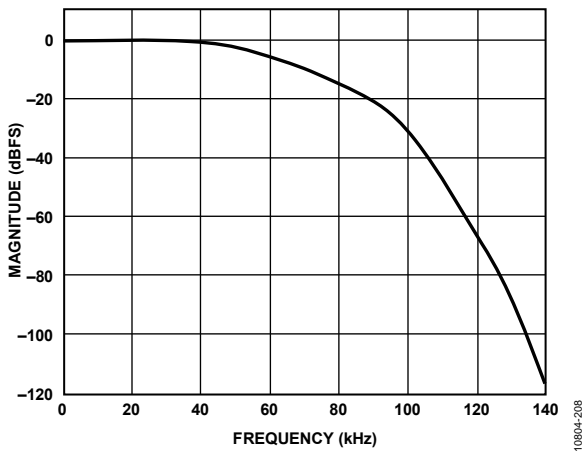

Figure 71. Total Decimation Response, Core  $f_s = 192$  kHz, Serial Port  $f_s = 192$  kHz

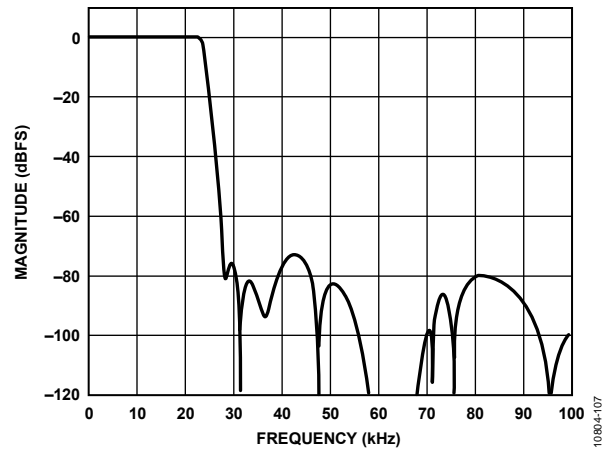

Figure 74. Total Interpolation Response,  $f_s = 192$  kHz

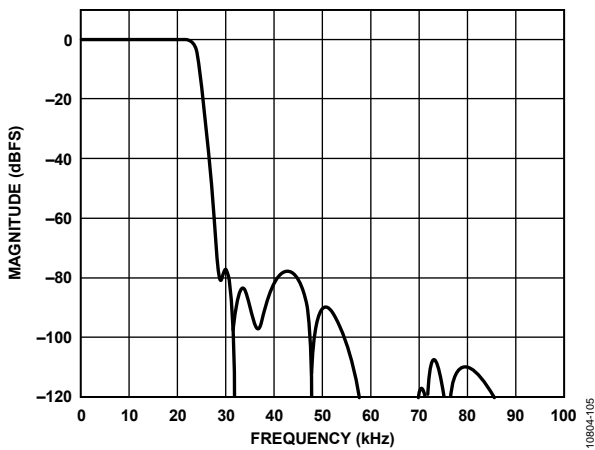

Figure 72. Total Interpolation Response,  $f_s = 96$  kHz

SYSTEM BLOCK DIAGRAMS

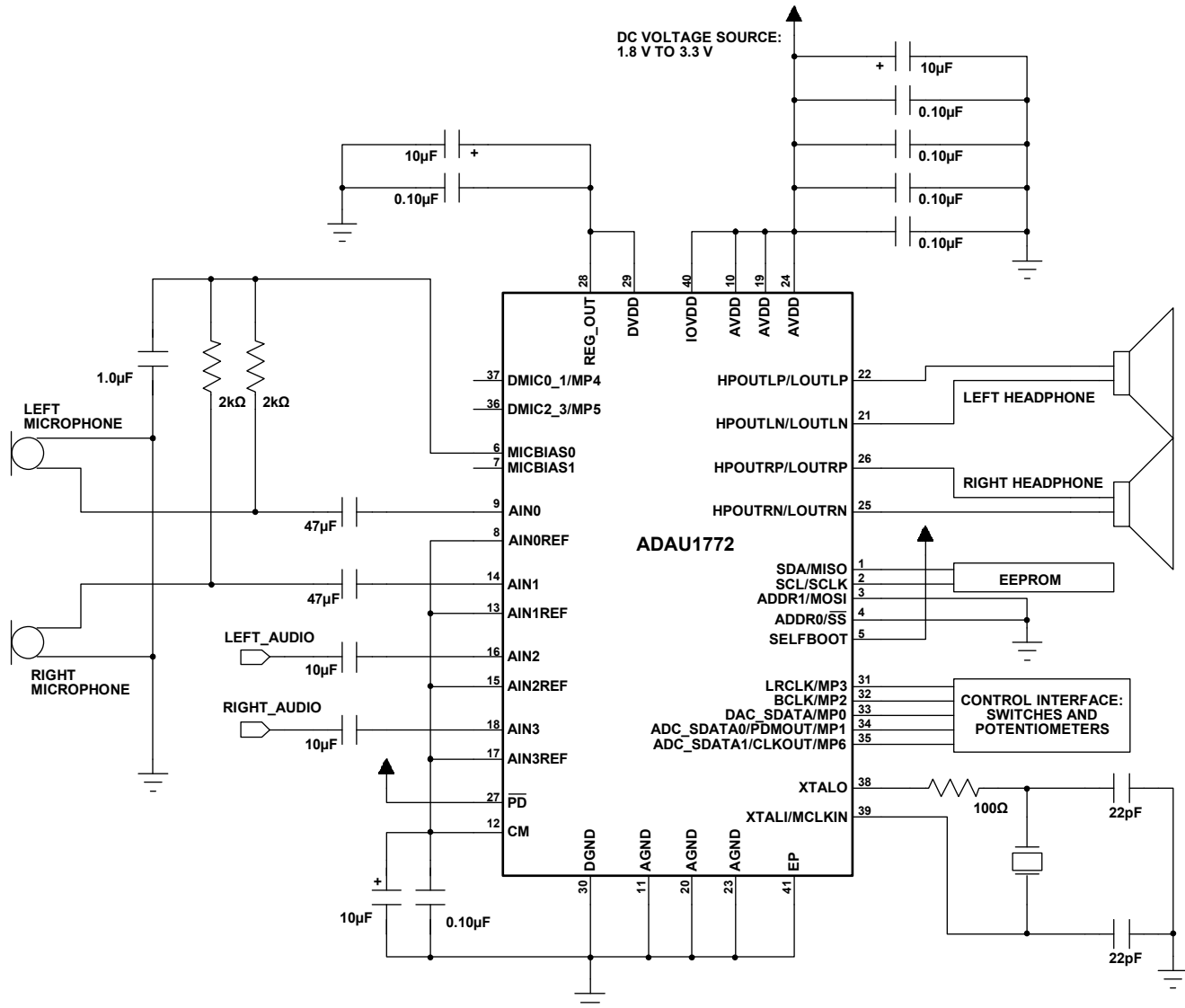

Figure 75. ADAU1772 System Block Diagram with Analog Microphones, Self-Boot Mode

10804-660

## THEORY OF OPERATION

The [ADAU1772](#) is a low power audio codec with an optimized audio processing core, making it ideal for noise cancelling applications that require high quality audio, low power, small size, and low latency. The four ADC and two DAC channels each have an SNR of at least +96 dB and a THD + N of at least -88 dB. The serial data port is compatible with I<sup>2</sup>S, left justified, right justified, and TDM modes, with tristating for interfacing to digital audio data. The operating voltage range is 1.8 V to 3.63 V, with an on-board regulator generating the internal digital supply voltage. If desired, the regulator can be powered down and the voltage can be supplied externally.

The input signal path includes flexible configurations that can accept single-ended analog microphone inputs as well as up to four digital microphone inputs. Two microphone bias pins provide seamless interfacing to electret microphones. Each input signal has its own programmable gain amplifier (PGA) for volume adjustment.

The ADCs and DACs are high quality, 24-bit  $\Sigma$ - $\Delta$  converters that operate at a selectable 192 kHz or 96 kHz sampling rate. The ADCs have an optional high-pass filter with a cutoff frequency of 1 Hz, 4 Hz, or 8 Hz. The ADCs and DACs also include very fine-step digital volume controls.

The stereo DAC output is capable of differentially driving a headphone earpiece speaker with 16  $\Omega$  impedance or higher. One side of the differential output can be powered down if single-ended operation is required. There is also the option to change to line output mode when the output is lightly loaded.

The core has a reduced instruction set that optimizes this codec for noise cancellation. The program and parameter RAMs can be loaded with custom audio processing signal flow built using the SigmaStudio™ graphical programming software from Analog Devices, Inc. The values stored in the parameter RAM

control individual signal processing blocks. The [ADAU1772](#) also has a self-boot function that can be used to load the program and parameter RAM along with the register settings on power-up using an external EEPROM.

The SigmaStudio software is used to program and control the core through the control port. Along with designing and tuning a signal flow, the tools can be used to configure all of the [ADAU1772](#) registers. The SigmaStudio graphical interface allows anyone with digital or analog audio processing knowledge to easily design the DSP signal flow and port it to a target application. The interface also provides enough flexibility and programmability for an experienced DSP programmer to have in-depth control of the design. In SigmaStudio, the user can connect graphical blocks (such as biquad filters, volume controls, and arithmetic operations), compile the design, and load the program and parameter files into the [ADAU1772](#) memory through the control port. SigmaStudio also allows the user to download the design to an external EEPROM for self-boot operation. Signal processing blocks available in the provided libraries include the following:

- Single-precision biquad filters
- Second order filters
- Absolute value and two-input adder
- Volume controls
- Limiter

The [ADAU1772](#) can generate its internal clocks from a wide range of input clocks by using the on-board fractional PLL. The PLL accepts inputs from 8 MHz to 27 MHz. For standalone operation, the clock can be generated using the on-board crystal oscillator.

The [ADAU1772](#) is provided in a small, 40-lead, 6 mm × 6 mm LFCSP with an exposed bottom pad.

## SYSTEM CLOCKING AND POWER-UP

### CLOCK INITIALIZATION

The ADAU1772 can generate its clocks either from an externally provided clock or from a crystal oscillator. In both cases, the on-board PLL can be used or the clock can be fed directly to the core. When a crystal oscillator is used, it is desirable to use a 12.288 MHz crystal, and the crystal oscillator function must be enabled in the COREN bit (Address 0x0000). If the PLL is used, it should always be set to output 24.576 MHz. The PLL can be bypassed if a clock of 12.288 MHz or 24.576 MHz is available in the system. Bypassing the PLL saves system power.

The CC\_MDIV and CC\_CDIV bits should not be changed after setup, but the CLKSRC bit can be switched while the core is running.

The CC\_MDIV and CC\_CDIV bits should be set so that the core and internal master clock are always 12.288 MHz; for example, when using a 24.576 MHz external source clock or if using the PLL, it is necessary to use the internal divide by 2 (see Table 11).

**Table 11. Clock Configuration Settings**

CC_MDIV	CC_CDIV	Description
1	1	Divide PLL/external clock by 1. Use these settings for a 12.288 MHz direct input clock source.
0	0	Divide PLL/external clock by 2. Use these settings for a 24.576 MHz direct input clock source or if using the PLL.

### PLL Bypass Setup

On power up, the ADAU1772 comes out of an internal reset after 12 ms. The rate of the internal master clock must be set properly using the CC\_MDIV bit in the clock control register (Address 0x0000). When bypassing the PLL, the clock associated with MCLKIN must be either 12.288 MHz or 24.576 MHz. The internal master clock of the ADAU1772 is disabled until the COREN bit is asserted.

### PLL Enabled Setup

The core clock of the ADAU1772 is disabled by the default setting of Bit COREN and should remain disabled during the PLL lock acquisition period. The user can poll the LOCK bit to determine when the PLL has locked. After lock is acquired, the ADAU1772 can be started by asserting the COREN bit. This bit enables the core clock for all the internal blocks of the ADAU1772.

To program the PLL during initialization or reconfiguration of the codec, the following procedure must be followed:

1. Ensure that PLL\_EN (Bit 7, Address 0x0000) is set low.
2. Set/reset the PLL control registers (Address 0x0001 to Address 0x0005).
3. Enable the PLL using the PLL\_EN bit.
4. Poll the PLL lock bit in Register 0x0006.
5. Set the COREN bit in Register 0x0000 after PLL lock is acquired.

### Control Port Access During Initialization

During the lock acquisition period, only Register 0x0000 to Register 0x0006 are accessible through the control port. A read or write to any other register is prohibited until the core clock enable bit and the lock bit are both asserted.

After the CORE\_RUN bit (Address 0x0009) is set high, the DAC\_SOURCE0 and DAC\_SOURCE1 register bits should not be changed. If these bits must be changed after the ADAU1772 is running, the CORE\_RUN bit first must be disabled.

### PLL

The PLL uses the MCLKIN signal as a reference to generate the core clock. The PLL settings are set in Register 0x0000 to Register 0x0005. Depending on the MCLK frequency, the PLL must be set for either integer or fractional mode. The PLL can accept input frequencies in the range of 8 MHz to 27 MHz.

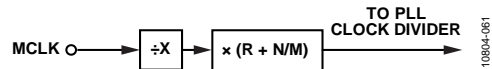

Figure 76. PLL Block Diagram

### Input Clock Divider

Before reaching the PLL, the input clock signal goes through an integer clock divider to ensure that the clock frequency is within a suitable range for the PLL. The X bits in the PLL\_CTRL4 register (Bits[2:1], Address 0x0005) sets the PLL input clock divide ratio.

### Integer Mode

Integer mode is used when the clock input is an integer multiple of the PLL output.

For example, if MCLKIN = 12.288 MHz and  $(X + 1) = 1$ , and  $f_s = 48$  kHz, then

$$PLL \text{ Required Output} = 24.576 \text{ MHz}$$

$$R/2 = 24.576 \text{ MHz}/12.288 \text{ MHz} = 2$$

where  $R/2 = 2$  or  $R = 4$ .

In integer mode, the values set for N and M are ignored. Table 12 lists common integer PLL parameter settings for 48 kHz sampling rates.

### Fractional Mode

Fractional mode is used when the clock input is a fractional multiple of the PLL output.

For example, if MCLKIN = 13 MHz,  $(X + 1) = 1$ , and  $f_s = 48$  kHz, then

$$PLL \text{ Required Output} = 24.576 \text{ MHz}$$

$$(1/2) \times (R + (N/M)) = 24.576 \text{ MHz}/13 \text{ MHz} = (1/2) \times (3 + (1269/1625))$$

where:

$$R = 3.$$

$$N = 1269.$$

$$M = 1625.$$

Table 13 lists common fractional PLL parameter settings for 48 kHz sampling rates. When the PLL is used in fractional mode, it is very important that the N/M fraction be kept in the range of 0.1 to 0.9 to ensure correct operation of the PLL.

The PLL can output a clock in the range of 20.5 MHz to 27 MHz, which should be taken into account when calculating PLL values and MCLK frequencies.

### CLOCK OUTPUT

The CLKOUT pin can be used as a master clock output to clock other ICs in the system or as the clock for the digital microphone inputs and PDM output. This clock can be generated from the 12.288 MHz master clock of the ADAU1772 by factors of 2, 1,  $\frac{1}{2}$ ,  $\frac{1}{4}$ , and  $\frac{1}{8}$ . If PDM mode is enabled, only  $\frac{1}{2}$ ,  $\frac{1}{4}$ , and  $\frac{1}{8}$  settings produce a clock signal on CLKOUT. The factor of 2 multiplier works properly only if the input clock was previously divided by 2 using the CC\_MDIV bit.

### POWER SEQUENCING

AVDD and IOVDD can each be set to any voltage between 1.8 V and 3.3 V, and DVDD can be set between 1.1 V and 1.8 V or between 1.1 V and 1.2 V if using the on-board regulator.

On power-up, AVDD must be powered up before or at the same time as IOVDD. IOVDD should not be powered up when power is not applied to AVDD.

Enabling the  $\overline{\text{PD}}$  pin powers down all analog and digital circuits. Before enabling  $\overline{\text{PD}}$  (that is, setting it low), be sure to mute the outputs to avoid any pops when the IC is powered down.

$\overline{\text{PD}}$  can be tied directly to IOVDD for normal operation.

### Power-Down Considerations

When powering down the ADAU1772, be sure to mute the outputs before AVDD power is removed; otherwise, pops or clicks may be heard. The easiest way to achieve this is to use a regulator that has a power good (PGOOD) signal to power the ADAU1772 or generate a power good signal using additional circuitry external to the regulator itself. Typically, on such regulators the power good signal changes state when the regulated voltage drops below ~90% of its target value. This power good signal can be connected to one of the ADAU1772 multipurpose pins and used to mute the DAC outputs by setting the multipurpose pin functionality to mute both DACs in Register 0x0038 to Register 0x003E. This ensures that the outputs are muted before power is completely removed.

Table 12. Integer PLL Parameter Settings for PLL Output = 24.576 MHz

MCLK Input (MHz)	Input Divider (X + 1)	Integer (R)	Denominator (M)	Numerator (N)	PLL_CTRL4 Settings (Address 0x0005)
12.288	1	4	Don't care	Don't care	0x20
24.576	1	2	Don't care	Don't care	0x10

Table 13. Fractional PLL Parameter Settings for PLL Output = 24.576 MHz

MCLK Input (MHz)	Input Divider (X + 1)	Integer (R)	Denominator (M)	Numerator (N)	PLL_CTRL[4:0] Settings (Address 0x0005 to Address 0x0001)				
					PLL_CTRL4 (0x0005)	PLL_CTRL3 (0x0004)	PLL_CTRL2 (0x0003)	PLL_CTRL1 (0x0002)	PLL_CTRL0 (0x0001)
8	1	6	125	18	0x31	0x12	0x00	0x7D	0x00
13	1	3	1625	1269	0x19	0xF5	0x04	0x59	0x06
14.4	2	6	75	62	0x33	0x3E	0x00	0x4B	0x00
19.2	2	5	25	3	0x2B	0x03	0x00	0x19	0x00
26	2	3	1625	1269	0x1B	0xF5	0x04	0x59	0x06
27	2	3	1125	721	0x1B	0xD1	0x02	0x65	0x04

SIGNAL ROUTING

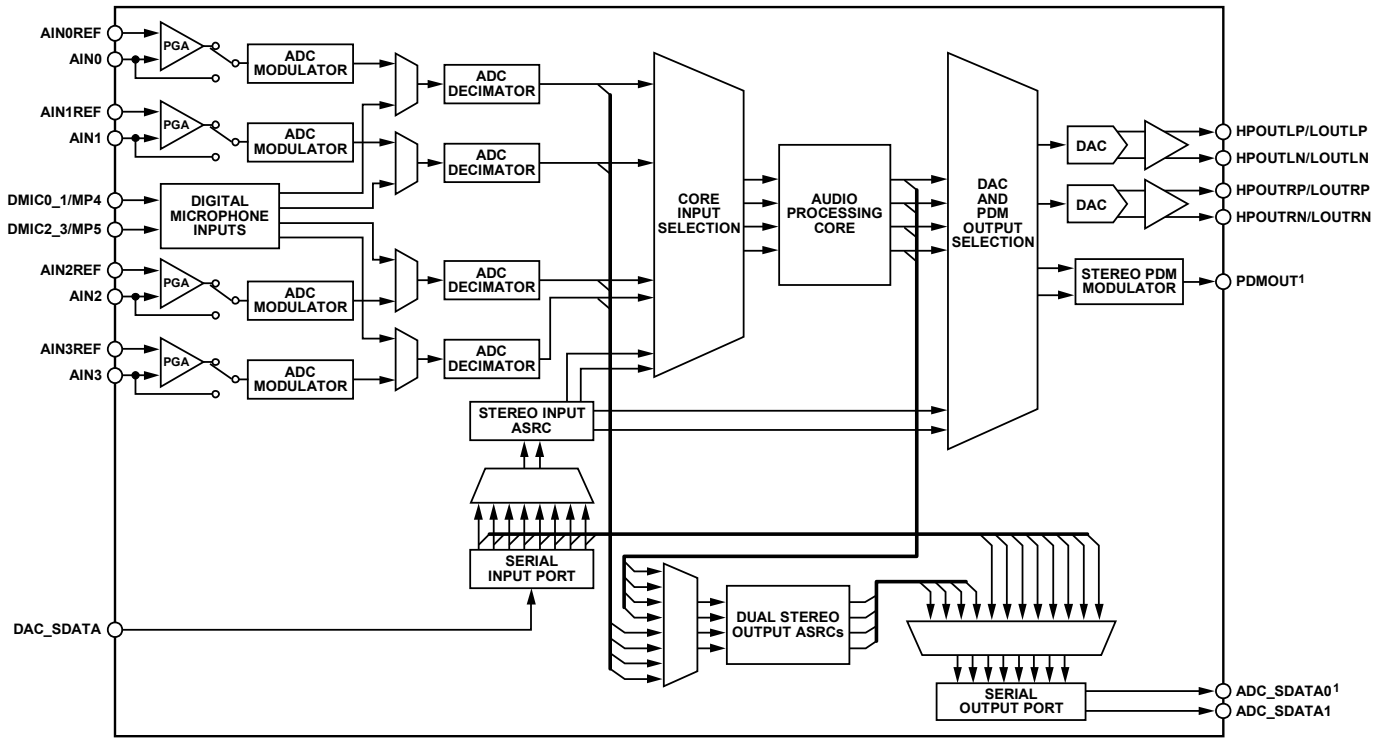

<sup>1</sup>THE ADC\_SDATA0 AND PDMOUT FUNCTIONS SHARE A PHYSICAL PIN, SO ONLY ONE OF THESE FUNCTIONS CAN BE USED AT A TIME.

Figure 77. Input and Output Signal Routing

10894-102Z

## INPUT SIGNAL PATHS

There are four input paths, from either an ADC or a digital microphone, that can be routed to the core. The input sources (ADC or digital microphone) must be configured in pairs (for example, 0 and 1, 2 and 3), but each channel can be routed individually. The core inputs can also be sourced from a stereo input ASRC.

### ANALOG INPUTS

The ADAU1772 can accept both line level and microphone inputs. Each of the four analog input channels can be configured in a single-ended mode or a single-ended with PGA mode. There are also inputs for up to four digital microphones. The analog inputs are biased at  $AVDD/2$ . Unused input pins should be connected to the CM pin or ac-coupled to ground.

#### Signal Polarity

Signals routed through the PGAs are inverted. As a result, signals input through the PGA are output from the ADCs with a polarity that is opposite that of the input. Single-ended inputs are not inverted. The ADCs are noninverting.

#### Input Impedance

The input impedance of the analog inputs varies with the gain of the PGA. This impedance ranges from 0.68 k $\Omega$  at the 35.25 dB gain setting to 32.0 k $\Omega$  at the -12 dB setting. The input impedance on each pin can be calculated as follows:

$$R_{IN} = \frac{40}{10^{(Gain/20)} + 1} \text{ k}\Omega$$

where *Gain* is set by PGA\_GAINx.

The optional 10 dB PGA boost set in PGA\_x\_BOOST does not affect the input impedance. This is an alternative way of increasing gain without decreasing input impedance; however, it causes some degradation in performance.

#### Analog Microphone Inputs

For microphone signals, the ADAU1772 analog inputs can be configured in single-ended with PGA mode.

The PGA settings are controlled in Register 0x0023 to Register 0x0026. The PGA is enabled by setting the PGA\_ENx bits.

Connect the AINxREF pins to the CM pin and connect the microphone signal to the inverting input of the PGAs (AINx), as shown in Figure 78.

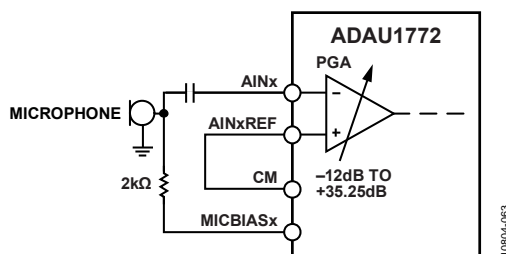

Figure 78. Single-Ended Microphone Configuration

### Analog Line Inputs

Line level signals can be input on the AINx pins of the analog inputs. Figure 79 shows a single-ended line input using the AINx pins. The AINxREF pins should be tied to CM. When using single-ended line input, the PGA should be disabled using the PGA\_ENx bits, and the corresponding PGA pop suppression bit should be disabled using the POP\_SUPPRESS register (Address 0x0029).

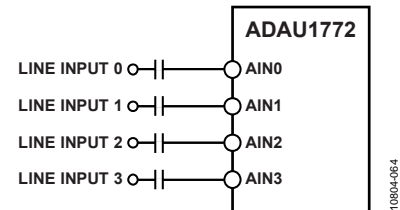

Figure 79. Single-Ended Line Inputs

### Precharging Input Capacitors

Precharge amplifiers are enabled by default to quickly charge large series capacitors on the inputs and outputs. Precharging these capacitors helps to prevent pops in the audio signal. The precharge circuits are powered up by default on startup and can be disabled in the POP\_SUPPRESS register. The precharge amplifiers are automatically disabled when the PGA or headphone amplifiers are enabled. For unused PGAs and headphone outputs, these precharge amplifiers should be disabled using the POP\_SUPPRESS register. The precharging time is dependent on the input/output series capacitors. The impedance looking into the pin is 500  $\Omega$  in this mode. However, at startup, the impedance looking into the pin is dominated by the time constant of the CM pin because the precharge amplifiers reference the CM voltage.

### Microphone Bias

The ADAU1772 includes two microphone bias outputs: MICBIAS0 and MICBIAS1. These pins provide a voltage reference for electret analog microphones. The MICBIASx pins can also be used to cleanly supply voltage to digital or analog MEMS microphones with separate power supply pins. The MICBIASx voltage is set in the microphone bias control register (Address 0x002D). Using this register, either the MICBIAS0 or MICBIAS1 output can be enabled and disabled. The gain options provide two possible voltages:  $0.65 \times AVDD$  or  $0.90 \times AVDD$ .

Many applications require enabling only one of the two bias outputs. The two bias outputs should both be enabled when many microphones are used in the system or when the positioning of the microphones on the PCB does not allow one pin to bias all microphones.

**DIGITAL MICROPHONE INPUT**

When using a digital microphone connected to the DMIC0\_1/MP4 and DMIC2\_3/MP5 pins, the DCM\_0\_1 and DCM\_2\_3 bits in Register 0x001D and Register 0x001E must be set to enable the digital microphone signal paths. The pin functions should also be set to digital microphone input in the corresponding pin mode registers (Address 0x003C and Address 0x003D). The DMIC0/DMIC2 and DMIC1/DMIC3 channels can be swapped (left/right swap) by writing to the DMIC\_SW0 and DMIC\_SW1 bits in the ADC\_CONTROL2 and ADC\_CONTROL3 registers (Address 0x001D and Address 0x001E). In addition, the microphone polarity can be reversed by setting the DMIC\_POLx bit, which reverses the phase of the incoming audio by 180°.

The digital microphone inputs are clocked from the CLKOUT pin. The digital microphone data stream must be clocked by this pin and not by a clock from another source, such as another audio IC, even if the other clock is of the same frequency as CLKOUT.

The digital microphone signal bypasses the analog input path and the ADCs and is routed directly into the decimation filters. The digital microphone and the ADCs share digital filters and, therefore, both cannot be used simultaneously. The digital microphone inputs are enabled in pairs. The ADAU1772 inputs can be set for either four analog inputs, four digital microphone inputs, or two analog inputs and two digital microphone inputs. Figure 80 depicts the digital microphone interface and signal routing.

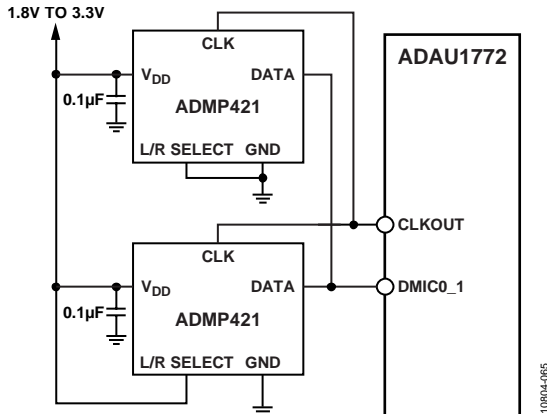

Figure 80. Digital Microphone Interface Block Diagram

Figure 80 shows two ADMP421 digital microphones connected to Pin DMIC0\_1 of the ADAU1772. These microphones could also be connected to DMIC2\_3 if that signal path is to be used for digital microphones. If more than two digital microphones are to be used in a system, then up to two microphones would be connected to both DMIC0\_1 and DMIC2\_3 and the CLKOUT signal would be fanned out to the clock input of all of the microphones.

**ANALOG-TO-DIGITAL CONVERTERS**

The ADAU1772 includes four 24-bit Σ-Δ analog-to-digital converters (ADCs) with a selectable sample rate of 192 kHz or 96 kHz.

**ADC Full-Scale Level**

The full-scale input to the ADCs (0 dBFS) scales linearly with AVDD. At AVDD = 3.3 V, the full-scale input level is 1 V rms. Signal levels above the full-scale value cause the ADCs to clip.

**Digital ADC Volume Control**

The volume setting of each ADC can be digitally attenuated in the ADCx\_VOLUME registers (Address 0x001F to Address 0x0022). The volume can be set between 0 dB and -95.625 dB in 0.375 dB steps. The ADC volume can also be digitally muted in the ADC\_CONTROLx registers (Address 0x001B to Address 0x001E).

**High-Pass Filter**

A high-pass filter is available on the ADC path to remove dc offsets; this filter can be enabled or disabled using the HP\_x\_x\_EN bits. At fs = 192 kHz, the corner frequency of this high-pass filter can be set to 1 Hz, 4 Hz, or 8 Hz.

## OUTPUT SIGNAL PATHS

Data from the serial input port can be routed to the core either directly or through a sample rate converter. Data can be routed to the serial output port, the stereo DAC, and the stereo PDM modulator.

The analog outputs of the ADAU1772 can be configured as differential or single-ended outputs. The analog output pins are capable of driving headphone or earpiece speakers. The line outputs can drive a load of at least 10 k $\Omega$  or can be put into headphone mode to drive headphones or earpiece speakers. The analog output pins are biased at AVDD/2.

### ANALOG OUTPUTS

#### Headphone Output

The output pins can be driven by either a line output driver or a headphone driver by setting the HP\_EN\_L and HP\_EN\_R bits in the headphone line output select register (Address 0x0043). The headphone outputs can drive a load of at least 16  $\Omega$ .

#### Headphone Output Power-Up Sequencing

To prevent pops when turning on the headphone outputs, the user must wait at least 6 ms to unmute these outputs after enabling the headphone output using the HP\_EN\_x bits. Waiting 6 ms allows an internal capacitor to charge before these outputs are used. Figure 81 illustrates the headphone output power-up sequencing.

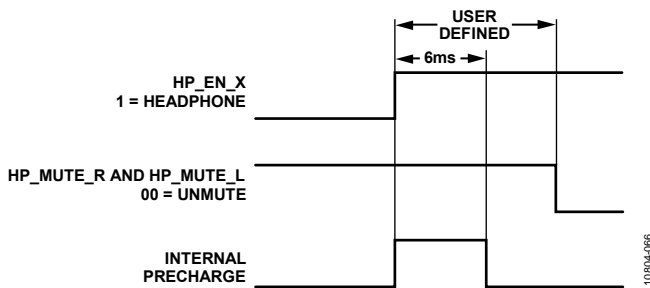

Figure 81. Headphone Output Power-Up Timing

#### Ground-Centered Headphone Configuration

The headphone outputs can also be configured as ground-centered outputs by connecting coupling capacitors in series with the output pins. Ground-centered headphones should use the AGND pin as the ground reference.

When the headphone outputs are configured in this manner, the capacitors create a high-pass filter on the outputs. The corner frequency of this filter, which has an attenuation of 3 dB at this point, is calculated by the following formula:

$$f_{3dB} = 1/(2\pi \times R \times C)$$

where :

R is the impedance of the headphones.

C is the capacitor value.

For a typical headphone impedance of 32  $\Omega$  and a 220  $\mu\text{F}$  capacitor, the corner frequency is 23 Hz.

#### Pop-and-Click Suppression

On power-up, the precharge circuitry is enabled on all four analog output pins to suppress pops and clicks. After power-up, the precharge circuitry can be put into a low power mode using the HP\_POP\_DISx bits in the POP\_SUPPRESS register (Address 0x0029).

The precharge time depends on the value of the capacitor connected to the CM pin and the RC time constant of the load on the output pin. For a typical line output load, the precharge time is between 2 ms and 3 ms. After this precharge time, the HP\_POP\_DISx bit can be set to low power mode.

To avoid clicks and pops, all analog outputs that are in use should be muted while changing any register settings that may affect the signal path. These outputs can then be unmuted after the changes have been made.

#### Line Outputs

The analog output pins (HPOUTLP/LOUTLP, HPOUTLN/LOUTLN, HPOUTRP/LOUTRP, and HPOUTRN/LOUTRN) can be used to drive both differential and single-ended loads. In their default settings, these pins can drive typical line loads of 10 k $\Omega$  or greater.

When the line output pins are used in single-ended mode, the HPOUTLP/LOUTLP and HPOUTRP/LOUTRP pins should be used to output the signals, and the HPOUTLN/LOUTLN and HPOUTRN/LOUTRN pins should be powered down.

### DIGITAL-TO-ANALOG CONVERTERS

The ADAU1772 includes two 24-bit  $\Sigma$ - $\Delta$  digital-to-analog converters (DACs).

#### DAC Full-Scale Level

The full-scale output from the DACs (0 dBFS) scales linearly with AVDD. At AVDD = 3.3 V, the full-scale output level is 1.94 V rms for a differential output or 0.97 V rms for a single-ended output.

#### Digital DAC Volume Control

The volume of each DAC can be digitally attenuated using the DACx\_VOLUME registers (Address 0x002F and Address 0x0030). The volume can be set to be between 0 dB and -95.625 dB in 0.375 dB steps.

### PDM OUTPUT

The ADAU1772 includes a 2-channel pulse density modulated (PDM) modulator. The PDMOUT pin can be used to drive a PDM input amplifier, such as the SSM2517 mono 2.4 W amplifier. Two SSM2517 devices can be connected to the PDMOUT data stream to enable a stereo output. The PDM output signal is clocked by the CLKOUT pin output. The PDM output stream must be clocked by this pin and not by a clock from another source, such as another audio IC, even if the other clock is of the same frequency as CLKOUT. The PDM output data is clipped at the -6 dB level to prevent overdriving a connected amplifier like the SSM2517.

The ADAU1772 has the ability to output PDM control patterns to configure devices such as the SSM2517. Each pattern is a byte long and is written with a user defined pattern in the PDM\_PATTERN register (Address 0x0037). The control pattern is enabled and the output channel selection is configured in the PDM\_OUT register (Address 0x0036). The PDM pattern should not be changed while the ADAU1772 is outputting the control pattern to the external device. After the external device is configured, the control pattern can be disabled. For the SSM2517, the control pattern must be repeated a minimum of 128 times to configure the part. Table 14 describes typical control patterns for the SSM2517.

**Table 14. SSM2517 PDM Control Pattern Descriptions**

Pattern	Control Description
0xAC	Power-down. All blocks off except for the PDM interface. Normal start-up time.
0xD8	Gain optimized for PVDD = 5 V operation. Overrides GAIN_FS pin setting.
0xD4	Gain optimized for PVDD = 3.6 V operation. Overrides GAIN_FS pin setting.
0xD2	Gain optimized for PVDD = 2.5 V operation. Overrides GAIN_FS pin setting.
0xD1	f <sub>s</sub> set to opposite value determined by GAIN_FS pin.
0xE1	Ultralow EMI mode.
0xE2	Half clock cycle pulse mode for power savings.
0xE4	Special 32 kHz/128 × f <sub>s</sub> operation mode.

**ASYNCHRONOUS SAMPLE RATE CONVERTERS**

The ADAU1772 includes asynchronous sample rate converters (ASRCs) to enable synchronous full-duplex operation of the serial ports. Two stereo ASRCs are available for the digital outputs, and one stereo ASRC is available for the digital input signals.

The ASRCs can convert serial output data from the core rate of up to 192 kHz back down to less than 8 kHz. All intermediate frequencies and ratios are also supported.

**SIGNAL LEVELS**

The ADCs, DACs, and ASRCs have fixed gain settings that should be considered when configuring the system. These settings were chosen to maximize performance of the converters and to ensure that there is 0 dB gain for any signal path from the input of the ADAU1772 to its output. Therefore, the full-scale level of a signal in the processing core will be slightly different from a full-scale level external to the IC.

Input paths, such as through the ADCs and input ASRCs, are scaled by 0.75, or about -2.5 dB. Output paths, such as through the DACs or output ASRCs, are scaled by 1.33, or about 2.5 dB. This is shown in Figure 82.

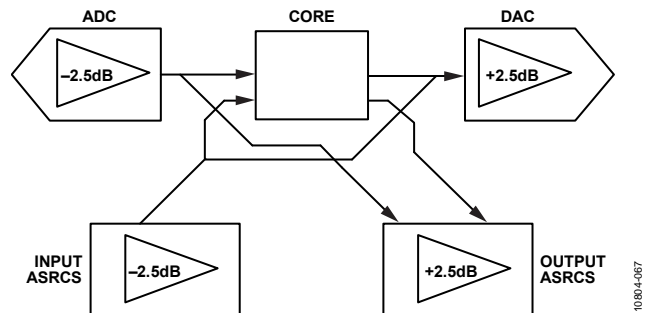

Figure 82. Signal Level Diagram

Because of this input and output scaling, output signals from the core should be limited to -2.5 dB full scale to prevent the DACs and ASRCs from clipping.

## SIGNAL PROCESSING

The ADAU1772 processing core is optimized for active noise cancelling (ANC) processing. The processing capabilities of the core include biquad filters, limiters, volume controls, and mixing. The core has four inputs and four outputs. The core is controlled with a 10-bit program word, with a maximum of 32 instructions per frame.

### INSTRUCTIONS

A complete list of instructions/processing blocks along with documentation can be found in the SigmaStudio software for the ADAU1772. The processing blocks available are

- Single-precision biquad/second order filters
- Absolute value
- Two-input addition
- T connection in SigmaStudio
- Limiter with/without external detector loop
- Linear gain
- Volume slider
- Mute
- DBREG level detection

### DATA MEMORY

The ADAU1772 data path is 26 bits (5.21 format). The data memory is 32 words of  $2 \times 26$  bits. The double length memory enables the core to double precision arithmetic with double length data and single length coefficients.

### PARAMETERS

Parameters, such as filter coefficients, limiter settings, and volume control settings, are saved in parameter registers. Each parameter is a 32-bit number. The format of this number depends on whether it is controlling a filter or a limiter. The number formats of different parameters are shown in Table 15. When the parameter formats use less than the full 32-bit memory space, as with the limiter parameters, the data is LSB-aligned.

**Table 15. Parameter Number Formats**

Parameter Type	Format
Filter Coefficient (B0, B1, B2)	5.27
Filter Coefficient (A1)	2.27 (sign extended)
Filter Coefficient (A2)	1.27 (sign extended)
Maximum Gain	2.23
Minimum Gain	2.23
Attack Time	24.0
Decay Time	24.0
Threshold	2.23

There are two parameter banks available. Each bank can hold a full set of 160 parameters (32 filters  $\times$  5 coefficients). Users can switch between Bank A and Bank B, allowing for two sets of parameters to be saved in memory and switched on the fly

while the codec is running. Bank switching can be achieved by writing to the CORE\_CONTROL register (Address 0x0009) or by using the multipurpose push-button switches, but not using a combination of the two. Parameters in the active bank should not be updated while the core is running; this will likely result in noises on the outputs.

Parameters are assigned to instructions in the order in which the instructions are instantiated in the code. The instruction types that use parameters are the biquad filters and limiters.

Table 17 shows the addresses of each parameter in Bank A that are associated with each of the 32 instructions, and Table 18 shows the addresses of each parameter in Bank B. Table 16 shows the addresses of the LSB aligned, 10-bit program words.

**Table 16. Program Addresses**

Instruction	Instruction Address
0	0x0080
1	0x0081
2	0x0082
3	0x0083
4	0x0084
5	0x0085
6	0x0086
7	0x0087
8	0x0088
9	0x0089
10	0x008A
11	0x008B
12	0x008C
13	0x008D
14	0x008E
15	0x008F
16	0x0090
17	0x0091
18	0x0092
19	0x0093
20	0x0094
21	0x0095
22	0x0096
23	0x0097
24	0x0098
25	0x0099
26	0x009A
27	0x009B
28	0x009C
29	0x009D
30	0x009E
31	0x009F

Table 17. Parameter Addresses, Bank A

Assignment Order	B0/Max Gain	B1/Min Gain	B2/Attack	A1/Decay	A2/Threshold
0	0x00E0	0x0100	0x0120	0x0140	0x0160
1	0x00E1	0x0101	0x0121	0x0141	0x0161
2	0x00E2	0x0102	0x0122	0x0142	0x0162
3	0x00E3	0x0103	0x0123	0x0143	0x0163
4	0x00E4	0x0104	0x0124	0x0144	0x0164
5	0x00E5	0x0105	0x0125	0x0145	0x0165
6	0x00E6	0x0106	0x0126	0x0146	0x0166
7	0x00E7	0x0107	0x0127	0x0147	0x0167
8	0x00E8	0x0108	0x0128	0x0148	0x0168
9	0x00E9	0x0109	0x0129	0x0149	0x0169
10	0x00EA	0x010A	0x012A	0x014A	0x016A
11	0x00EB	0x010B	0x012B	0x014B	0x016B
12	0x00EC	0x010C	0x012C	0x014C	0x016C
13	0x00ED	0x010D	0x012D	0x014D	0x016D
14	0x00EE	0x010E	0x012E	0x014E	0x016E
15	0x00EF	0x010F	0x012F	0x014F	0x016F
16	0x00F0	0x0110	0x0130	0x0150	0x0170
17	0x00F1	0x0111	0x0131	0x0151	0x0171
18	0x00F2	0x0112	0x0132	0x0152	0x0172
19	0x00F3	0x0113	0x0133	0x0153	0x0173
20	0x00F4	0x0114	0x0134	0x0154	0x0174
21	0x00F5	0x0115	0x0135	0x0155	0x0175
22	0x00F6	0x0116	0x0136	0x0156	0x0176
23	0x00F7	0x0117	0x0137	0x0157	0x0177
24	0x00F8	0x0118	0x0138	0x0158	0x0178
25	0x00F9	0x0119	0x0139	0x0159	0x0179
26	0x00FA	0x011A	0x013A	0x015A	0x017A
27	0x00FB	0x011B	0x013B	0x015B	0x017B
28	0x00FC	0x011C	0x013C	0x015C	0x017C
29	0x00FD	0x011D	0x013D	0x015D	0x017D
30	0x00FE	0x011E	0x013E	0x015E	0x017E
31	0x00FF	0x011F	0x013F	0x015F	0x017F

Table 18. Parameter Addresses, Bank B

Assignment Order	B0/Max Gain	B1/Min Gain	B2/Attack	A1/Decay	A2/Threshold
0	0x0180	0x01A0	0x01C0	0x01E0	0x0200
1	0x0181	0x01A1	0x01C1	0x01E1	0x0201
2	0x0182	0x01A2	0x01C2	0x01E2	0x0202
3	0x0183	0x01A3	0x01C3	0x01E3	0x0203
4	0x0184	0x01A4	0x01C4	0x01E4	0x0204
5	0x0185	0x01A5	0x01C5	0x01E5	0x0205
6	0x0186	0x01A6	0x01C6	0x01E6	0x0206
7	0x0187	0x01A7	0x01C7	0x01E7	0x0207
8	0x0188	0x01A8	0x01C8	0x01E8	0x0208
9	0x0189	0x01A9	0x01C9	0x01E9	0x0209
10	0x018A	0x01AA	0x01CA	0x01EA	0x020A
11	0x018B	0x01AB	0x01CB	0x01EB	0x020B
12	0x018C	0x01AC	0x01CC	0x01EC	0x020C
13	0x018D	0x01AD	0x01CD	0x01ED	0x020D
14	0x018E	0x01AE	0x01CE	0x01EE	0x020E
15	0x018F	0x01AF	0x01CF	0x01EF	0x020F

Assignment Order	B0/Max Gain	B1/Min Gain	B2/Attack	A1/Decay	A2/Threshold
16	0x0190	0x01B0	0x01D0	0x01F0	0x0210
17	0x0191	0x01B1	0x01D1	0x01F1	0x0211
18	0x0192	0x01B2	0x01D2	0x01F2	0x0212
19	0x0193	0x01B3	0x01D3	0x01F3	0x0213
20	0x0194	0x01B4	0x01D4	0x01F4	0x0214
21	0x0195	0x01B5	0x01D5	0x01F5	0x0215
22	0x0196	0x01B6	0x01D6	0x01F6	0x0216
23	0x0197	0x01B7	0x01D7	0x01F7	0x0217
24	0x0198	0x01B8	0x01D8	0x01F8	0x0218
25	0x0199	0x01B9	0x01D9	0x01F9	0x0219
26	0x019A	0x01BA	0x01DA	0x01FA	0x021A
27	0x019B	0x01BB	0x01DB	0x01FB	0x021B
28	0x019C	0x01BC	0x01DC	0x01FC	0x021C
29	0x019D	0x01BD	0x01DD	0x01FD	0x021D
30	0x019E	0x01BE	0x01DE	0x01FE	0x021E
31	0x019F	0x01BF	0x01DF	0x01FF	0x021F

## CONTROL PORT

The ADAU1772 has both a 4-wire SPI control port and a 2-wire I<sup>2</sup>C bus control port. Each can be used to set the memories and registers. The IC defaults to I<sup>2</sup>C mode but can be put into SPI control mode by pulling the  $\overline{SS}$  pin low three times.

The control port is capable of full read/write operation for all addressable memories and registers. Most signal processing parameters are controlled by writing new values to the parameter memories using the control port. Other functions, such as mute and input/output mode control, are programmed through the registers.

All addresses can be accessed in either single-address mode or burst mode. The first byte (Byte 0) of a control port write contains the 7-bit IC address plus the R/W bit. The next two bytes (Byte 1 and Byte 2) are the 16-bit subaddress of the memory or register location within the ADAU1772. All subsequent bytes (starting with Byte 3) contain the data, such as register data, program data, or parameter data. The number of bytes per word depends on the type of data that is being written. Table 19 shows the word length of the ADAU1772's different data types. The exact formats for specific types of writes are shown in Figure 85 and Figure 86.

**Table 19. Data Word Sizes**

Data Type	Word Size (bytes)
Registers	1
Program	2
Parameters	4

If large blocks of data need to be downloaded to the ADAU1772, the output of the core can be halted (using the CORE\_RUN bit in the core control register (Address 0x0009)), new data can be loaded, and then the core can be restarted. This is typically done during the booting sequence at start-up or when loading a new program into memory.

Registers and bits shown as reserved in the register map read back 0s. When writing to these registers and bits, such as during a burst write across a reserved register, or when writing to reserved bits in a register with other used bits, write 0s.

The control port pins are multifunctional, depending on the mode in which the part is operating. Table 20 details these multiple functions.

**Table 20. Control Port Pin Functions**

Pin	I <sup>2</sup> C Mode	SPI Mode
SCL/SCLK	SCL—input	SCLK—input
SDA/MISO	SDA—open-collector output	MISO—output
ADDR1/MOSI	I <sup>2</sup> C Address Bit 1—input	MOSI—input
ADDR0/ $\overline{SS}$	I <sup>2</sup> C Address Bit 0—input	$\overline{SS}$ —input

## BURST MODE COMMUNICATION

Burst mode addressing, in which the subaddresses are automatically incremented at word boundaries, can be used for writing

large amounts of data to contiguous memory locations. This increment happens automatically after a single-word write unless the control port communication is stopped (that is, a stop condition is issued for I<sup>2</sup>C, or  $\overline{SS}$  is brought high for SPI). The registers and RAMs in the ADAU1772 range in width from one to four bytes, so the auto-increment feature knows the mapping between subaddresses and the word length of the destination register (or memory location).

## I<sup>2</sup>C PORT

The ADAU1772 supports a 2-wire serial (I<sup>2</sup>C-compatible) microprocessor bus driving multiple peripherals. I<sup>2</sup>C uses two pins—serial data (SDA) and serial clock (SCL)—to carry data between the ADAU1772 and the system I<sup>2</sup>C master controller. In I<sup>2</sup>C mode, the ADAU1772 is always a slave on the bus, except when the IC is self-booting. See the Self-Boot section for details about using the ADAU1772 in self-boot mode.

Each slave device is recognized by a unique 7-bit address. The ADAU1772 I<sup>2</sup>C address format is shown in Table 21. The LSB of this first byte sent from the I<sup>2</sup>C master sets either a read or write operation. Logic Level 1 corresponds to a read operation, and Logic Level 0 corresponds to a write operation.

Pin ADDR0 and Pin ADDR1 set the LSBs of the I<sup>2</sup>C address (Table 22); therefore, each ADAU1772 can be set to one of four unique addresses. This allows multiple ICs to exist on the same I<sup>2</sup>C bus without address contention. The 7-bit I<sup>2</sup>C addresses are shown in Table 22.

An I<sup>2</sup>C data transfer is always terminated by a stop condition.

Both SDA and SCL should have 2.0 k $\Omega$  pull-up resistors on the lines connected to them. The voltage on these signal lines should not be higher than IOVDD.

**Table 21. I<sup>2</sup>C Address Format**

Bit 6	Bit 5	Bit 4	Bit 3	Bit 2	Bit 1	Bit 0
0	1	1	1	1	ADDR1	ADDR0

**Table 22. I<sup>2</sup>C Addresses**

ADDR1	ADDR0	Slave Address
0	0	0x3C
0	1	0x3D
1	0	0x3E
1	1	0x3F

## Addressing

Initially, each device on the I<sup>2</sup>C bus is in an idle state and monitoring the SDA and SCL lines for a start condition and the proper address. The I<sup>2</sup>C master initiates a data transfer by establishing a start condition, defined by a high-to-low transition on SDA while SCL remains high. This indicates that an address/data stream follows. All devices on the bus respond to the start condition and shift the next eight bits (the 7-bit address plus the

R/W bit) MSB first. The device that recognizes the transmitted address responds by pulling the data line low during the ninth clock pulse. This ninth bit is known as an acknowledge bit. All other devices withdraw from the bus at this point and return to the idle condition. The R/W bit determines the direction of the data. A Logic 0 on the LSB of the first byte indicates that the master will write information to the peripheral, whereas a Logic 1 indicates that the master will read information from the peripheral after writing the subaddress and repeating the start address. A data transfer takes place until a stop condition is encountered. A stop condition occurs when SDA transitions from low to high while SCL is held high. Figure 83 shows the timing of an I<sup>2</sup>C write, and Figure 84 shows an I<sup>2</sup>C read.

Stop and start conditions can be detected at any stage during the data transfer. If these conditions are asserted out of sequence with normal read and write operations, the ADAU1772 immediately

jumps to the idle condition. During a given SCL high period, the user should only issue one start condition, one stop condition, or a single stop condition followed by a single start condition. If an invalid subaddress is issued by the user, the ADAU1772 does not issue an acknowledge and returns to the idle condition. If the user exceeds the highest subaddress while in auto-increment mode, one of two actions is taken. In read mode, the ADAU1772 outputs the highest subaddress register contents until the master device issues a no acknowledge, indicating the end of a read. A no-acknowledge condition is where the SDA line is not pulled low on the ninth clock pulse on SCL. If the highest subaddress location is reached while in write mode, the data for the invalid byte is not loaded into any subaddress register, a no acknowledge is issued by the ADAU1772, and the part returns to the idle condition.

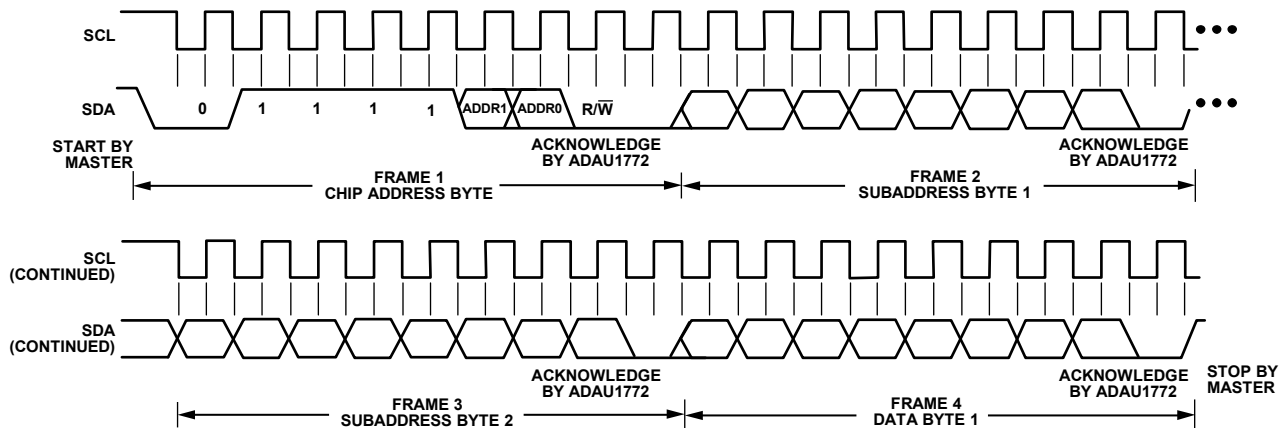

Figure 83. I<sup>2</sup>C Write to ADAU1772 Clocking

10804-069

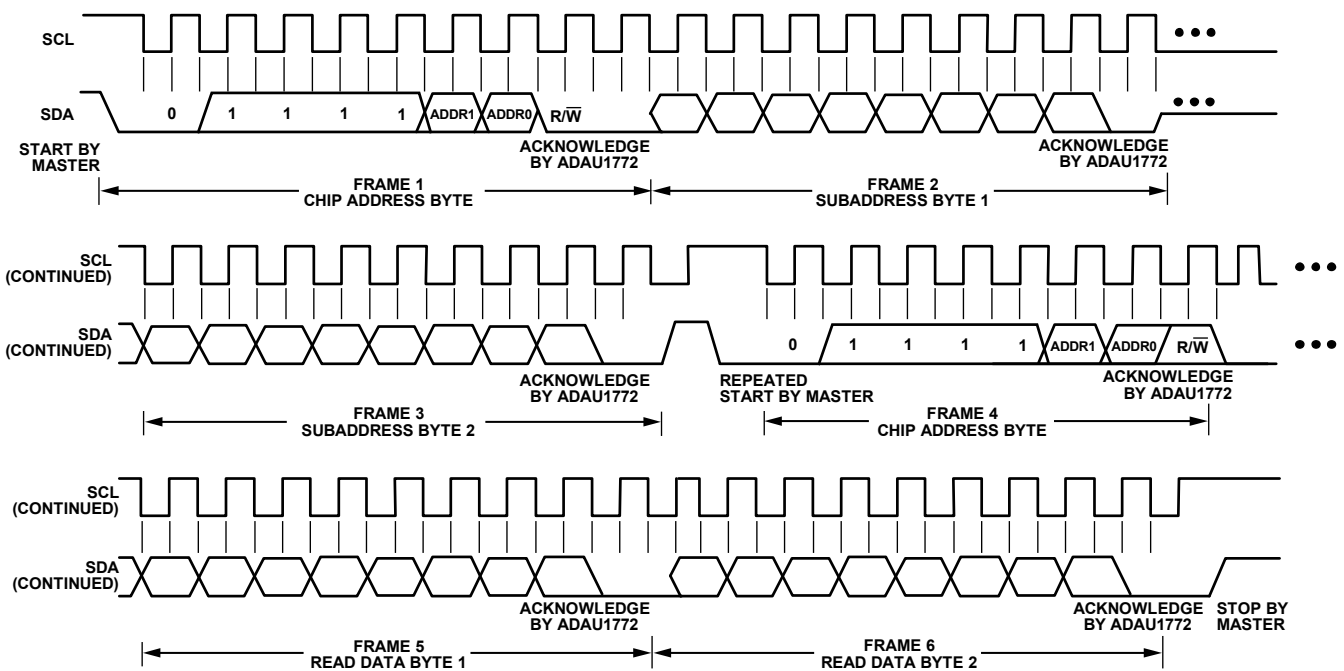

Figure 84. I<sup>2</sup>C Read from ADAU1772 Clocking

10804-069

**I<sup>2</sup>C Read and Write Operations**

Figure 85 shows the timing of a single-word write operation. Every ninth clock pulse, the ADAU1772 issues an acknowledge by pulling SDA low.

Figure 86 shows the timing of a burst mode write sequence. This figure shows an example where the target destination words are two bytes, such as the program memory. The ADAU1772 knows to increment its subaddress register every two bytes because the requested subaddress corresponds to a register or memory area with a 2-byte word length.

The timing of a single-word read operation is shown in Figure 87. Note that the first R/W bit is 0, indicating a write operation. This is because the subaddress still needs to be written to set up the internal address. After the ADAU1772 acknowledges the receipt of the subaddress, the master must issue a repeated start command followed by the chip address byte with the R/W set to 1 (read). This causes the ADAU1772 SDA to reverse and begin driving data

back to the master. The master then responds every ninth pulse with an acknowledge pulse to the ADAU1772.

Figure 88 shows the timing of a burst mode read sequence. This figure shows an example where the target read words are two bytes. The ADAU1772 increments its subaddress every two bytes because the requested subaddress corresponds to a register or memory area with word lengths of two bytes. Other address ranges may have a variety of word lengths, ranging from one to four bytes. The ADAU1772 always decodes the subaddress and sets the auto-increment circuit so that the address increments after the appropriate number of bytes.

Figure 85 to Figure 88 use the following abbreviations:

- S = start bit
- P = stop bit
- AM = acknowledge by master
- AS = acknowledge by slave

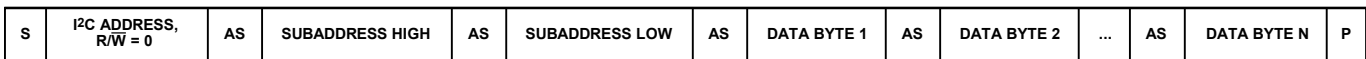

Figure 85. Single-Word I<sup>2</sup>C Write Format

10804-070



Figure 86. Burst Mode I<sup>2</sup>C Write Format

10804-071



Figure 87. Single-Word I<sup>2</sup>C Read Format

10804-072

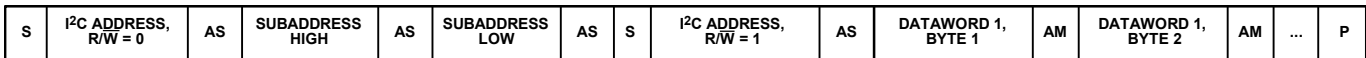

Figure 88. Burst Mode I<sup>2</sup>C Read Format

10804-073

**SPI PORT**

By default, the ADAU1772 is in I<sup>2</sup>C mode, but it can be put into SPI control mode by pulling  $\overline{SS}$  low three times. This can be easily accomplished by issuing three SPI writes, which are in turn ignored by the ADAU1772. The next (fourth) SPI write is then latched into the SPI port.

The SPI port uses a 4-wire interface—consisting of  $\overline{SS}$ , SCLK, MOSI, and MISO signals—and is always a slave port. The  $\overline{SS}$  signal should go low at the beginning of a transaction and high at the end of a transaction. The SCLK signal latches MOSI on a low-to-high transition. MISO data is shifted out of the ADAU1772 on the falling edge of SCLK and should be clocked into a receiving device, such as a microcontroller, on the SCLK rising edge. The MOSI signal carries the serial input data, and the MISO signal is the serial output data. The MISO signal remains tristated until a read operation is requested. This allows other SPI-compatible peripherals to share the same readback line.

All SPI transactions have the same basic format shown in Table 23. A timing diagram is shown in Figure 89 and Figure 90. All data should be written MSB first. The ADAU1772 can only be taken out of SPI mode by pulling the  $\overline{PD}$  pin low or by powering down the IC.

**Read/Write**

The first byte of an SPI transaction indicates whether the communication is a read or a write with the R/W bit. The LSB of this first byte determines whether the SPI transaction is a read (Logic Level 1) or a write (Logic Level 0).

**Subaddress**

The 16-bit subaddress word is decoded into a location in one of the memories or registers. This subaddress is the location of the appropriate memory location or register.

**Data Bytes**

The number of data bytes varies according to the register or memory being accessed. During a burst mode write, an initial subaddress is written followed by a continuous sequence of data for consecutive memory/register locations.

A sample timing diagram for a single-write SPI operation to the parameter RAM is shown in Figure 89. A sample timing diagram of a single-read SPI operation is shown in Figure 90. The MISO pin goes from tristate to being driven at the beginning of Byte 3. In this example, Byte 0 to Byte 2 contain the addresses and the R/W bit and subsequent bytes carry the data.

**Table 23. Generic SPI Word Format**

Byte 0	Byte 1	Byte 2	Byte 3	Byte 4 <sup>1</sup>
0000000, R/ $\overline{W}$	Register/memory address [15:8]	Register/memory address [7:0]	data	data

<sup>1</sup> Continues to end of data.

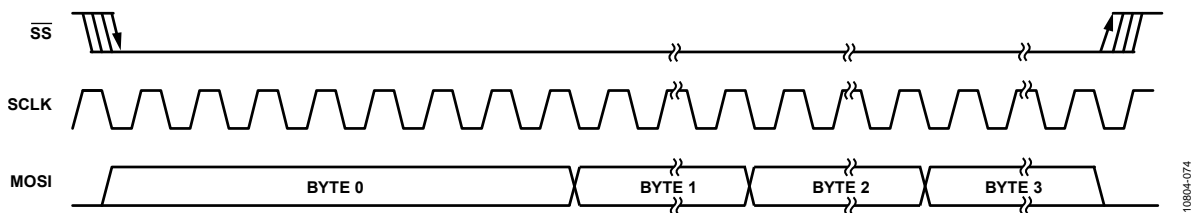

Figure 89. SPI Write to ADAU1772 Clocking (Single-Write Mode)

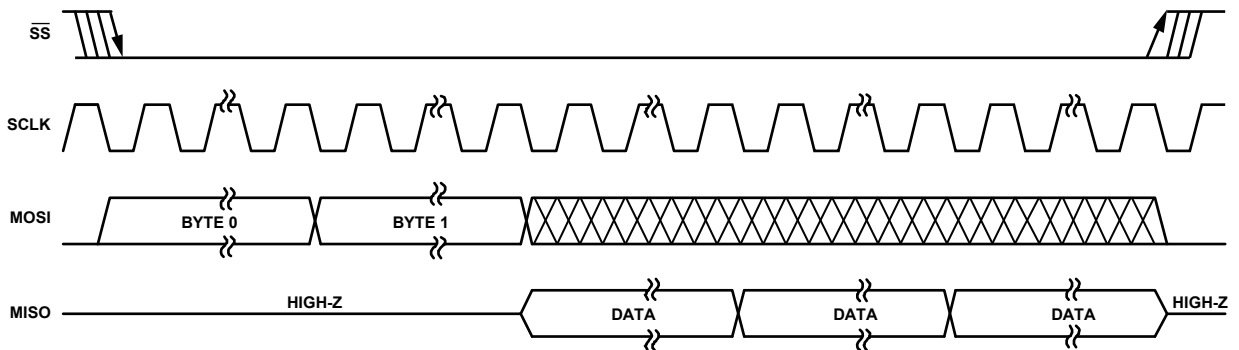

Figure 90. SPI Read from ADAU1772 Clocking (Single-Read Mode)

**SELF-BOOT**

The ADAU1772 boots up from an EEPROM over the I<sup>2</sup>C bus when the SELFBOOT pin is set high at power-up and the PD pin is set high. The state of the SELFBOOT pin is checked only when the ADAU1772 comes out of a reset via the PD pin, and the EEPROM is not used after a self-boot is complete. During booting, ensure that there is a stable DVDD in the system. The PD pin should remain high during the self-boot operation. The master SCL clock output from the ADAU1772 is derived from the input clock on XTALI/MCLKIN. A divide-by-64 circuit ensures that the SCL output frequency during the self-boot operation is never greater than 400 kHz for most input clock frequencies. With the external master clock to the ADAU1772 being between 12 MHz and 27 MHz, the SCL frequency ranges from 176 kHz to 422 kHz. If the self-boot EEPROM is not rated for operation above 400 kHz, be sure to use a master clock that is no faster than 25.6 MHz.

Table 25 shows the list of instructions that are possible during an ADAU1772 self-boot. The 0x01 and 0x05 instruction bytes are used to load the register, program, and parameter settings.

**EEPROM Size**

The self-boot circuit is compatible with an EEPROM that has a 2-byte address. For most EEPROM families, a 2-byte address is used on devices that are 32 kB or larger. The EEPROM must be set to Address 0x50. Examples of two compatible EEPROMs include Atmel AT24C32D and STMicroelectronics M24C32-F.

Table 24 lists the maximum necessary EEPROM size, assuming that there is 100% utilization of the program and parameters (both banks). There is inherently some overhead for instructions to control the self-boot procedure.

**Table 24. Maximum EEPROM Size**

ADAU1772 Memory Blocks	Word Size (Bytes per Word)	Words	Total EEPROM Space Requirement (Bytes)
Program	2	32	64
Bank 0 Parameters	4	160 (32 × 5)	640
Bank 1 Parameters	4	160	640
Registers	1	65	65
Total Bytes			1409

**CRC**

An 8-bit CRC validates the content of the EEPROM. This CRC is strong enough to detect single error bursts of up to eight bits in size.

The terminate self-boot instruction (0x00 instruction byte) must be followed by a CRC byte. The CRC is generated using all of the EEPROM bytes from Address 0x0000 to the last 0x00 instruction byte. The polynomial for the CRC is

$$x^8 + x^2 + x + 1$$

If the CRC is incorrect or if an unrecognized instruction byte is read during self-boot, the boot process is immediately stopped and restarted after a 250 ms delay (for a 12.288 MHz input clock). When SigmaStudio is used, the CRC byte is generated automatically when a configuration is downloaded to the EEPROM.

**Delay**

The delay instruction (0x02 instruction byte) delays by the 16-bit setting × 2048 clock cycles.

**Boot Time**

The time to self-boot the ADAU1772 from an EEPROM can be calculated using the following equation:

$$Boot\ Time = 64 / MCLK\ Frequency \times Total\ Bytes + Wait\ Time$$

The self-boot operation starts after 16,568 clock cycles are seen on the XTALI/MCLKIN pin after PD is set high. With a 12.288 MHz clock, this corresponds to approximately a 1.35 ms wait time from power-up. This delay ensures that the crystal used for generating the master clock has ramped up to a stable oscillation.

**Table 25. EEPROM Self-Boot Instructions**

Instruction Byte ID	Instruction Byte Description	Following Bytes
0x00	End self-boot	CRC
0x01	Write multibyte length minus two bytes, starting at target address	Length (high byte), length (low byte), address (high byte), address (low byte), data (0), data (1), ... data (length – 3)
0x02	Delays by the 16-bit setting × 2048 clock cycles	Delay (high byte), delay (low byte)
0x03	No operation	None
0x04	Wait for PLL lock	None
0x05	Write single byte to target address	Address (high byte), address (low byte), data

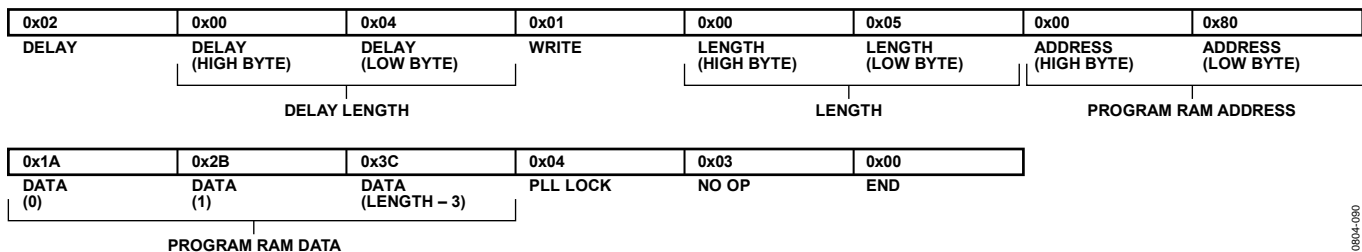

Figure 91. A List of Example Self-Boot EEPROM Instructions

## MULTIPURPOSE PINS

The ADAU1772 has seven multipurpose (MP) pins that can be used for serial data I/O, clock outputs, and control in a system without a microcontroller. Each pin can be individually set to either its default or MP setting. The functions include push-button volume controls, enabling the compressors, parameter bank switching, DSP bypass mode, and muting the outputs.

The function of each of these pins is set in Register 0x0038 to Register 0x003E. By default, each pin is configured as an input.

**Table 26. Multipurpose Pin Functions**

Pin No.	Default Pin Function	Secondary Pin Functions
31	LRCLK	Multipurpose control inputs
32	BCLK	Multipurpose control inputs
33	DAC_SDATA	Multipurpose control inputs
34	MP1 acting as push-button volume up	ADC_SDATA0, PDM output, multipurpose control inputs
35	MP6 acting as push-button volume down	ADC_SDATA1, CLKOUT, multipurpose control inputs
36	DMIC2_3	Multipurpose control inputs
37	DMIC0_1	Multipurpose control inputs

### PUSH-BUTTON VOLUME CONTROLS

The ADC and DAC volume controls can be set up to be controlled with two push-buttons—one for volume up and one for volume down. The volume setting can either be changed with a click of the button or be ramped by holding the button. The volume settings change when the signal on the pin from the button goes from low to high.

When in push-button mode, the initial volume level is set with Bits PB\_VOL\_INIT\_VAL. By default, MP1 acts as the push-button volume up and MP6 acts as the push-button volume down; however, any of the MPx pins can be set to act as the push-button up and push-button down volume controls.

When the ADC and/or DAC volumes are controlled with the push-buttons, the corresponding volume control registers no longer allow control of the volume from the control port.

Therefore, writing to these volume control registers has no effect on the codec volume level.

### LIMITER COMPRESSION ENABLE

This function allows a user to enable limiter compression regardless of the signal level. Setting an MPx pin low when this function is enabled causes the limiter to compress the incoming signal by the minimum gain setting. When the MPx pin is released, the limiter resumes normal behavior.

### PARAMETER BANK SWITCHING

An MPx pin can be used to switch the active parameter bank between Bank A and Bank B. When this setting is selected, Bank A is active when the pin is high and Bank B is active when the pin is low. Care should be taken to set the BANK\_SL bits in the CORE\_CONTROL register (Address 0x0009) to the default value of 0x00 before enabling MPx pin control over bank switching. Simultaneous control of bank switching by both register setting and MPx pin selection is not possible.

Bit ZERO\_STATE selects whether the data memory of the codec is set to 0 during a bank switch. If the data is not set to 0 when a new set of filter coefficients is enabled via a bank switch, there may be a pop in the audio as the old data is circulated in the new filters.

### MUTE

The MPx pins can be put into a mode to mute the ADCs or DACs. When in this mode, mute is enabled when an MPx pin is set low. The full combination of possible mutes for ADCs and DACs using MPx pins are set in Register 0x0038 to Register 0x003E.

**DSP BYPASS MODE**

When DSP bypass mode is enabled, a direct path from the ADC outputs to the DACs is set up to enable bypassing the core processing to listen to environmental sounds. This is useful for listening to someone speaking without having to remove the noise cancelling headphones. The DSP bypass path is enabled by setting an MPx pin low. Figure 92 shows the DSP bypass path disabled, and Figure 93 shows the DSP bypass path enabled by pressing the push-button switch. The DSP bypass feature works for both analog and digital microphone inputs.

DSP bypass is enabled when a switch connected to an MPx pin that is set to DSP bypass mode is closed and the MPx pin signal

is pulled low. Pressing and holding the switch closed enables the DSP bypass signal path as defined in the TALKTHRU register (Address 0x002A). The DAC volume control setting is switched from the default gain setting to the new TALKTHRU\_GAINx register setting (Address 0x002B and Address 0x002C). DSP bypass is enabled only on ADC0 and ADC1. The DSP bypass signal path is from the output of ADCx to the input of the DAC(s).

When DSP bypass is enabled, the current DAC volume setting is ramped down to -95.625 dB and the DSP bypass volume setting is ramped up to avoid pops when switching paths.

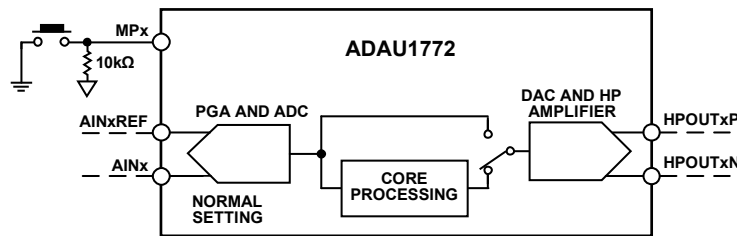

Figure 92. DSP Bypass Path Disabled

10804-076

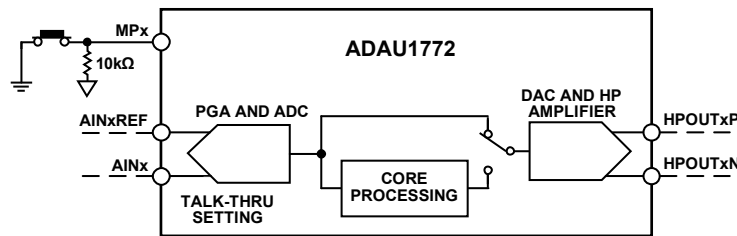

Figure 93. DSP Bypass Path Enabled

10804-077

## SERIAL DATA INPUT/OUTPUT PORTS

The serial data input and output ports of the ADAU1772 can be set to accept or transmit data in a 2-channel format or in a 4-channel or 8-channel TDM stream to interface to external ADCs, DACs, DSPs, and SOCs. Data is processed in twos complement, MSB first format. The left-channel data field always precedes the right-channel data field in the 2-channel streams. In 8-channel TDM mode, the data channels are output sequentially, starting with the channel set by the ADC\_SDATA0\_ST and ADC\_SDATA1\_ST bits. The serial modes and the position of the data in the frame are set in the serial data port (SAI\_0, SAI\_1) and serial output control registers (SOUT\_SOURCE\_x\_x, Address 0x0013 to Address 0x0016).

The serial data clocks do not need to be synchronous with the ADAU1772 master clock input, but the LRCLK and BCLK must be synchronous to each other. The LRCLK and BCLK pins are used to clock both the serial input and output ports. The ADAU1772 can be set to be either the master or the slave in a system. Because there is only one set of serial data clocks, the input and output ports must always both be either master or slave.

The serial data control registers allow control of the clock polarity and the data input modes. The valid data formats are I<sup>2</sup>S, left justified, right justified (24- or 16-bit), PCM, and TDM. In all modes except for the right justified modes, the serial port inputs an arbitrary number of bits up to a limit of 24. Extra bits do not cause an error, but they are truncated internally. The serial port can operate with an arbitrary number of BCLK transitions in each LRCLK frame. The LRCLK in TDM mode can be input to the ADAU1772 either as a 50% duty cycle clock or as a bit-wide pulse. Table 27 lists the modes in which the serial input/output port can function. When using low IOVDD (1.8 V) with a high

BCLK rate (12.288 MHz), a sample rate of 192 kHz, or a TDM8 mode operating at a sample rate of 48 kHz, it is recommended to use the high drive settings on the serial port pins. The high drive strength effectively speeds up the transition times of the waveforms, thereby improving the signal integrity of the clock and data lines. These can be set in the PAD\_CONTROL4 register (Address 0x004C).

Table 27. Serial In/Out Port Master/Slave Mode Capabilities

f <sub>SSD</sub>	2-Channel Modes (I <sup>2</sup> S, Left Justified, Right Justified)	4-Channel TDM	8-Channel TDM
48 kHz	Yes	Yes	Yes
96 kHz	Yes	Yes	No
192 kHz	Yes	No	No

Table 28 describes the proper serial port settings for standard audio data formats. More information about the settings in this table can be found in the Serial Port Control 0 and Serial Port Control 1 registers (Address 0x0032 and Address 0x0033) descriptions.

### TRISTATING UNUSED CHANNELS

Unused outputs can be tristated so that multiple ICs can drive a single TDM line. This function is available only when the serial ports of the ADAU1772 are operating in TDM mode. Channels that are inactive can be set in the SOUT\_CONTROL0 register (Address 0x0034). The tristating of inactive channels is set in the SAI\_1 register (Address 0x0033), which offers the option of tristating or driving the inactive channel.

In a 32-bit TDM frame with 24-bit data, the eight unused bits are tristated. Inactive channels are also tristated for the full frame.

Table 28. Serial Port Data Format Settings

Format	LRCLK Polarity (LR_POL)	LRCLK Type (LR_MODE)	BCLK Polarity (BCLKEDGE) <sup>1</sup>	MSB Position (SDATA_FMT)
I <sup>2</sup> S (Figure 94)	0	0	0	00
Left Justified (Figure 95)	1	0	0	01
Right Justified (Figure 96 and Figure 97)	1	0	0	10 or 11
TDM (Figure 98 and Figure 99)	1	0 or 1	0	00
PCM/DSP Short Frame Sync (Figure 100)	1	1	X	00
PCM/DSP Long Frame Sync (Figure 101)	1	0	X	01

<sup>1</sup> X = don't care.

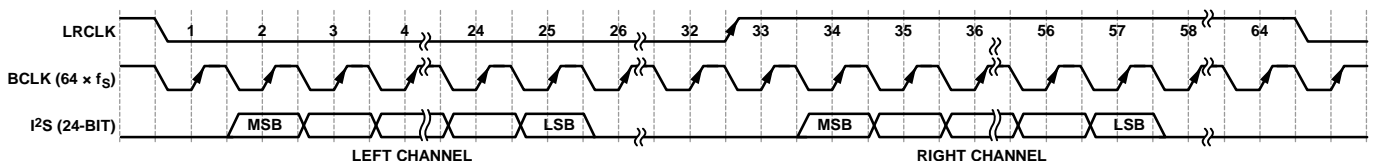

Figure 94. I<sup>2</sup>S Mode—16 Bits to 24 Bits per Channel

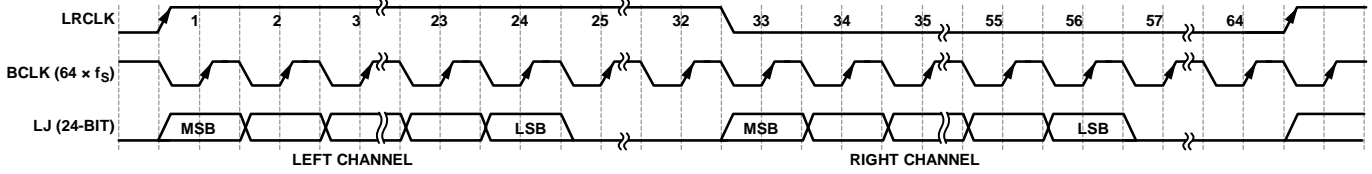

Figure 95. Left Justified Mode—16 Bits to 24 Bits per Channel

10804-079

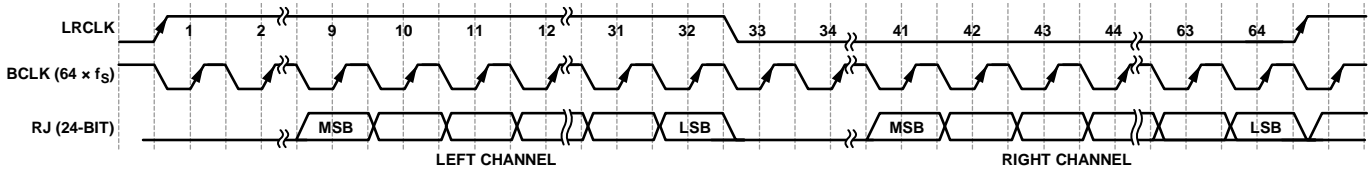

Figure 96. Right Justified Mode—24 Bits per Channel

10804-080

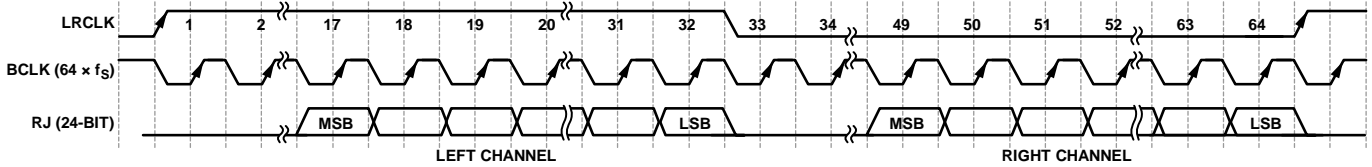

Figure 97. Right Justified Mode—16 Bits per Channel

10804-081

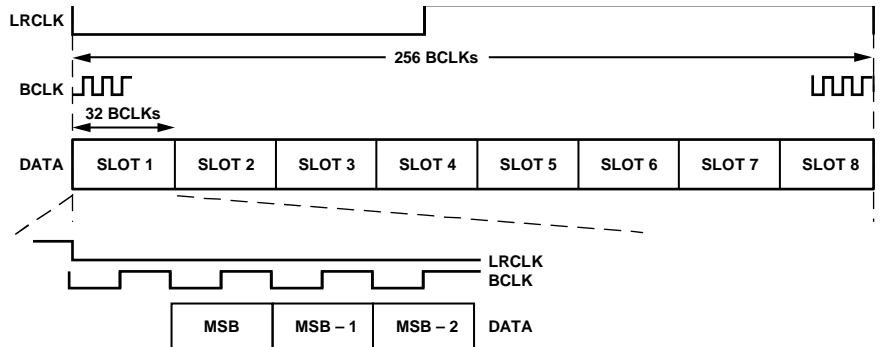

Figure 98. 8-Channel TDM Mode

10804-082

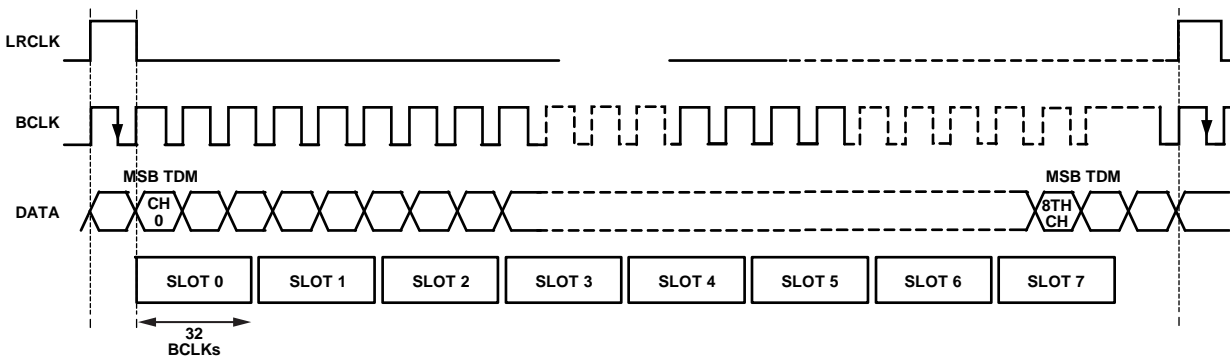

Figure 99. 8-Channel TDM Mode, Pulse LRCLK

10804-083

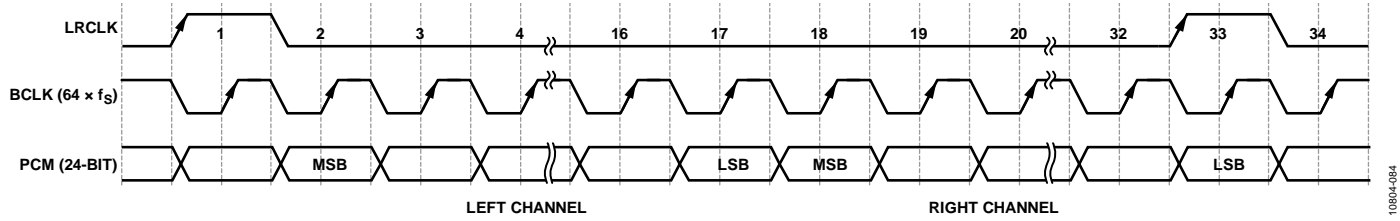

Figure 100. PCM/DSP Mode, 16 Bits per Channel, Short Frame Sync

10804-084

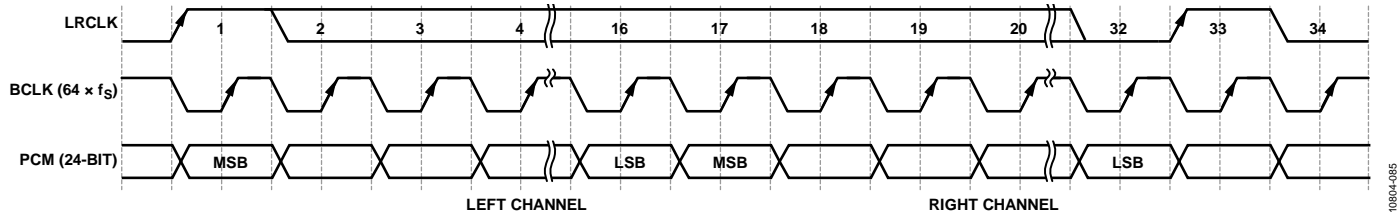

Figure 101. PCM/DSP Mode, 16 Bits per Channel, Long Frame Sync

10804-085

## APPLICATIONS INFORMATION

### POWER SUPPLY BYPASS CAPACITORS

Each analog and digital power supply pin should be bypassed to its nearest appropriate ground pin with a single 0.1  $\mu\text{F}$  capacitor. The connections to each side of the capacitor should be as short as possible, and the trace should be routed on a single layer with no vias. For maximum effectiveness, locate the capacitor equidistant from the power and ground pins or slightly closer to the power pin if equidistant placement is not possible. Thermal connections to the ground planes should be made on the far side of the capacitor.

Each supply signal on the board should also be bypassed with a single bulk capacitor (10  $\mu\text{F}$  to 47  $\mu\text{F}$ ).

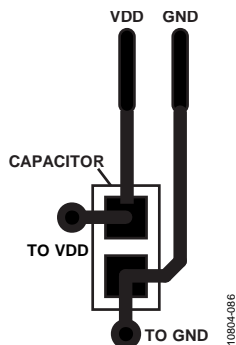

Figure 102. Recommended Power Supply Bypass Capacitor Layout

### LAYOUT

Pin 24 is the AVDD supply for the headphone amplifiers. If the headphone amplifiers are enabled, the PCB trace to this pin should be wider than traces to other pins to increase the current carrying capacity. A wider trace should also be used for the headphone output lines.

### GROUNDING

A single ground plane should be used in the application layout. Components in an analog signal path should be placed away from digital signals.

### EXPOSED PAD PCB DESIGN

The ADAU1772 has an exposed pad on the underside of the LFCSP. This pad is used to couple the package to the PCB for heat dissipation. When designing a board for the ADAU1772, special consideration should be given to the following:

- A copper layer equal in size to the exposed pad should be on all layers of the board, from top to bottom, and should connect somewhere to a dedicated copper board layer (see Figure 103).
- Vias should be placed to connect all layers of copper, allowing for efficient heat and energy conductivity. For an example, see Figure 104, which has nine vias arranged in a 3  $\times$  3 grid in the pad area.

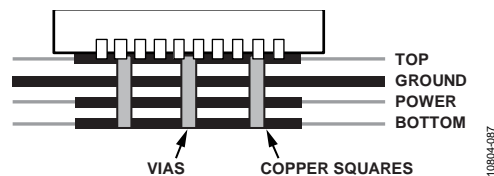

Figure 103. Exposed Pad Layout Example, Side View (Not to Scale)

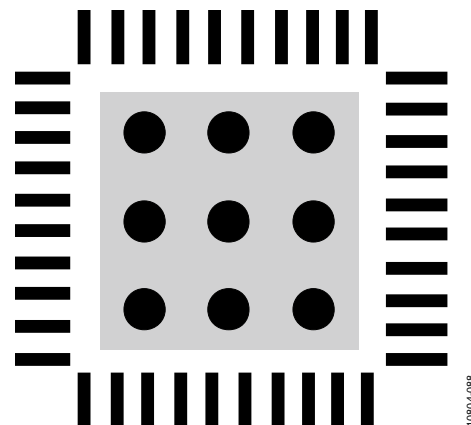

Figure 104. Exposed Pad Layout Example, Top View (Not to Scale)

## REGISTER SUMMARY

Table 29. Low Latency Codec Register Summary

Reg	Name	Bits	Bit 7	Bit 6	Bit 5	Bit 4	Bit 3	Bit 2	Bit 1	Bit 0	Reset	RW	
0x0000	CLK_CONTROL	[7:0]	PLL_EN	RESERVED	SPK_FLT_DIS	XTAL_DIS	CLKSRC	CC_CDIV	CC_MDIV	COREN	0x00	RW	
0x0001	PLL_CTRL0	[7:0]	M_MSB								0x00	RW	
0x0002	PLL_CTRL1	[7:0]	M_LSB								0x00	RW	
0x0003	PLL_CTRL2	[7:0]	N_MSB								0x00	RW	
0x0004	PLL_CTRL3	[7:0]	N_LSB								0x00	RW	
0x0005	PLL_CTRL4	[7:0]	RESERVED	R				X		PLL_TYPE	0x00	RW	
0x0006	PLL_CTRL5	[7:0]	RESERVED							LOCK	0x00	R	
0x0007	CLKOUT_SEL	[7:0]	RESERVED					CLKOUT_FREQ				0x00	RW
0x0008	REGULATOR	[7:0]	RESERVED					REG_PD	REGV			0x00	RW
0x0009	CORE_CONTROL	[7:0]	ZERO_STATE	BANK_SL		RESERVED		CORE_FS		CORE_RUN	0x04	RW	
0x000B	CORE_ENABLE	[7:0]	RESERVED							LIM_EN	DSP_CLK_EN	0x03	RW
0x000C	DBREG0	[7:0]	DBVAL0								0x00	R	
0x000D	DBREG1	[7:0]	DBVAL1								0x00	R	
0x000E	DBREG2	[7:0]	DBVAL2								0x00	R	
0x000F	CORE_IN_MUX_0_1	[7:0]	CORE_IN_MUX_SEL_1				CORE_IN_MUX_SEL_0				0x10	RW	
0x0010	CORE_IN_MUX_2_3	[7:0]	CORE_IN_MUX_SEL_3				CORE_IN_MUX_SEL_2				0x32	RW	
0x0011	DAC_SOURCE_0_1	[7:0]	DAC_SOURCE1				DAC_SOURCE0				0x10	RW	
0x0012	PDM_SOURCE_0_1	[7:0]	PDM_SOURCE1				PDM_SOURCE0				0x32	RW	
0x0013	SOUT_SOURCE_0_1	[7:0]	SOUT_SOURCE1				SOUT_SOURCE0				0x54	RW	
0x0014	SOUT_SOURCE_2_3	[7:0]	SOUT_SOURCE3				SOUT_SOURCE2				0x76	RW	
0x0015	SOUT_SOURCE_4_5	[7:0]	SOUT_SOURCE5				SOUT_SOURCE4				0x54	RW	
0x0016	SOUT_SOURCE_6_7	[7:0]	SOUT_SOURCE7				SOUT_SOURCE6				0x76	RW	
0x0017	ADC_SDATA_CH	[7:0]	RESERVED					ADC_SDATA1_ST	ADC_SDATA0_ST			0x04	RW
0x0018	ASRCO_SOURCE_0_1	[7:0]	ASRC_OUT_SOURCE1				ASRC_OUT_SOURCE0				0x10	RW	
0x0019	ASRCO_SOURCE_2_3	[7:0]	ASRC_OUT_SOURCE3				ASRC_OUT_SOURCE2				0x32	RW	
0x001A	ASRC_MODE	[7:0]	RESERVED					ASRC_IN_CH	ASRC_OUT_EN	ASRC_IN_EN	0x00	RW	
0x001B	ADC_CONTROL0	[7:0]	RESERVED		RESERVED	ADC1_MUTE	ADC0_MUTE	RESERVED	ADC_0_1_FS		0x19	RW	
0x001C	ADC_CONTROL1	[7:0]	RESERVED		RESERVED	ADC3_MUTE	ADC2_MUTE	RESERVED	ADC_2_3_FS		0x19	RW	
0x001D	ADC_CONTROL2	[7:0]	RESERVED	HP_0_1_EN		DMIC_POL0	DMIC_SW0	DCM_0_1	ADC_1_EN	ADC_0_EN	0x00	RW	
0x001E	ADC_CONTROL3	[7:0]	RESERVED	HP_2_3_EN		DMIC_POL1	DMIC_SW1	DCM_2_3	ADC_3_EN	ADC_2_EN	0x00	RW	
0x001F	ADC0_VOLUME	[7:0]	ADC_0_VOL								0x00	RW	
0x0020	ADC1_VOLUME	[7:0]	ADC_1_VOL								0x00	RW	
0x0021	ADC2_VOLUME	[7:0]	ADC_2_VOL								0x00	RW	
0x0022	ADC3_VOLUME	[7:0]	ADC_3_VOL								0x00	RW	
0x0023	PGA_CONTROL_0	[7:0]	PGA_EN0	PGA_MUTE0	PGA_GAIN0						0x40	RW	
0x0024	PGA_CONTROL_1	[7:0]	PGA_EN1	PGA_MUTE1	PGA_GAIN1						0x40	RW	
0x0025	PGA_CONTROL_2	[7:0]	PGA_EN2	PGA_MUTE2	PGA_GAIN2						0x40	RW	
0x0026	PGA_CONTROL_3	[7:0]	PGA_EN3	PGA_MUTE3	PGA_GAIN3						0x40	RW	
0x0027	PGA_STEP_CONTROL	[7:0]	RESERVED			SLEW_RATE		SLEW_PD3	SLEW_PD2	SLEW_PD1	SLEW_PD0	0x00	RW
0x0028	PGA_10DB_BOOST	[7:0]	RESERVED					PGA_3_BOOST	PGA_2_BOOST	PGA_1_BOOST	PGA_0_BOOST	0x00	RW
0x0029	POP_SUPPRESS	[7:0]	RESERVED		HP_POP_DIS1	HP_POP_DIS0	PGA_POP_DIS3	PGA_POP_DIS2	PGA_POP_DIS1	PGA_POP_DIS0	0x3F	RW	
0x002A	TALKTHRU	[7:0]	RESERVED							TALKTHRU_PATH		0x00	RW
0x002B	TALKTHRU_GAIN0	[7:0]	TALKTHRU_GAIN0_VAL								0x00	RW	
0x002C	TALKTHRU_GAIN1	[7:0]	TALKTHRU_GAIN1_VAL								0x00	RW	
0x002D	MIC_BIAS	[7:0]	RESERVED		MIC_EN1	MIC_EN0	RESERVED	RESERVED	MIC_GAIN1	MIC_GAIN0	0x00	RW	
0x002E	DAC_CONTROL1	[7:0]	RESERVED		DAC_POL	DAC1_MUTE	DAC0_MUTE	RESERVED	DAC1_EN	DAC0_EN	0x18	RW	
0x002F	DAC0_VOLUME	[7:0]	DAC_0_VOL								0x00	RW	
0x0030	DAC1_VOLUME	[7:0]	DAC_1_VOL								0x00	RW	
0x0031	OP_STAGE_MUTES	[7:0]	RESERVED					HP_MUTE_R		HP_MUTE_L		0x0F	RW
0x0032	SAL_0	[7:0]	SDATA_FMT			SAI		SER_PORT_FS				0x00	RW
0x0033	SAL_1	[7:0]	TDM_TS	BCLK_TDMC	LR_MODE	LR_POL	SAI_MSB	BCLKRATE	BCLKEDGE	SAI_MS	0x00	RW	
0x0034	SOUT_CONTROLO	[7:0]	TDM7_DIS	TDM6_DIS	TDM5_DIS	TDM4_DIS	TDM3_DIS	TDM2_DIS	TDM1_DIS	TDM0_DIS	0x00	RW	
0x0036	PDM_OUT	[7:0]	RESERVED			PDM_CTRL	PDM_CH		PDM_EN		0x00	RW	
0x0037	PDM_PATTERN	[7:0]	PATTERN								0x00	RW	
0x0038	MODE_MP0	[7:0]	RESERVED				MODE_MP0_VAL				0x00	RW	
0x0039	MODE_MP1	[7:0]	RESERVED				MODE_MP1_VAL				0x10	RW	
0x003A	MODE_MP2	[7:0]	RESERVED				MODE_MP2_VAL				0x00	RW	
0x003B	MODE_MP3	[7:0]	RESERVED				MODE_MP3_VAL				0x00	RW	
0x003C	MODE_MP4	[7:0]	RESERVED				MODE_MP4_VAL				0x00	RW	

Reg	Name	Bits	Bit 7	Bit 6	Bit 5	Bit 4	Bit 3	Bit 2	Bit 1	Bit 0	Reset	RW	
0x003D	MODE_MP5	[7:0]	RESERVED			RESERVED			MODE_MP5_VAL			0x00	RW
0x003E	MODE_MP6	[7:0]	RESERVED			RESERVED			MODE_MP6_VAL			0x11	RW
0x003F	PB_VOL_SET	[7:0]	PB_VOL_INIT_VAL				HOLD				0x00	RW	
0x0040	PB_VOL_CONV	[7:0]	GAINSTEP		RAMPSPEED		PB_VOL_CONV_VAL				0x87	RW	
0x0041	DEBOUNCE_MODE	[7:0]	RESERVED				DEBOUNCE				0x05	RW	
0x0043	OP_STAGE_CTRL	[7:0]	RESERVED		HP_EN_R	HP_EN_L	HP_PDN_R		HP_PDN_L		0x0F	RW	
0x0044	DECIM_PWR_MODES	[7:0]	DEC_3_EN	DEC_2_EN	DEC_1_EN	DEC_0_EN	SINC_3_EN	SINC_2_EN	SINC_1_EN	SINC_0_EN	0x00	RW	
0x0045	INTERP_PWR_MODES	[7:0]	RESERVED				MOD_1_EN	MOD_0_EN	INT_1_EN	INT_0_EN	0x00	RW	
0x0046	BIAS_CONTROL0	[7:0]	HP_IBIAS		AFE_IBIAS01		ADC_IBIAS23		ADC_IBIAS01		0x00	RW	
0x0047	BIAS_CONTROL1	[7:0]	RESERVED	CBIAS_DIS	AFE_IBIAS23		MIC_IBIAS		DAC_IBIAS		0x00	RW	
0x0048	PAD_CONTROL0	[7:0]	RESERVED	DMIC2_3_PU	DMIC0_1_PU	LRCLK_PU	BCLK_PU	ADC_SDATA1_PU	ADC_SDATA0_PU	DAC_SDATA_PU	0x7F	RW	
0x0049	PAD_CONTROL1	[7:0]	RESERVED			SELFBOOT_PU	SCL_PU	SDA_PU	ADDR1_PU	ADDR0_PU	0x1F	RW	
0x004A	PAD_CONTROL2	[7:0]	RESERVED	DMIC2_3_PD	DMIC0_1_PD	LRCLK_PD	BCLK_PD	ADC_SDATA1_PD	ADC_SDATA0_PD	DAC_SDATA_PD	0x00	RW	
0x004B	PAD_CONTROL3	[7:0]	RESERVED			SELFBOOT_PD	SCL_PD	SDA_PD	ADDR1_PD	ADDR0_PD	0x00	RW	
0x004C	PAD_CONTROL4	[7:0]	RESERVED	RESERVED	RESERVED	LRCLK_DRV	BCLK_DRV	ADC_SDATA1_DRV	ADC_SDATA0_DRV	RESERVED	0x00	RW	
0x004D	PAD_CONTROLS5	[7:0]	RESERVED			RESERVED	SCL_DRV	SDA_DRV	RESERVED	RESERVED	0x00	RW	

## REGISTER DETAILS

### CLOCK CONTROL REGISTER

Address: 0x0000, Reset: 0x00, Name: CLK\_CONTROL

This register is used to enable the internal clocks.

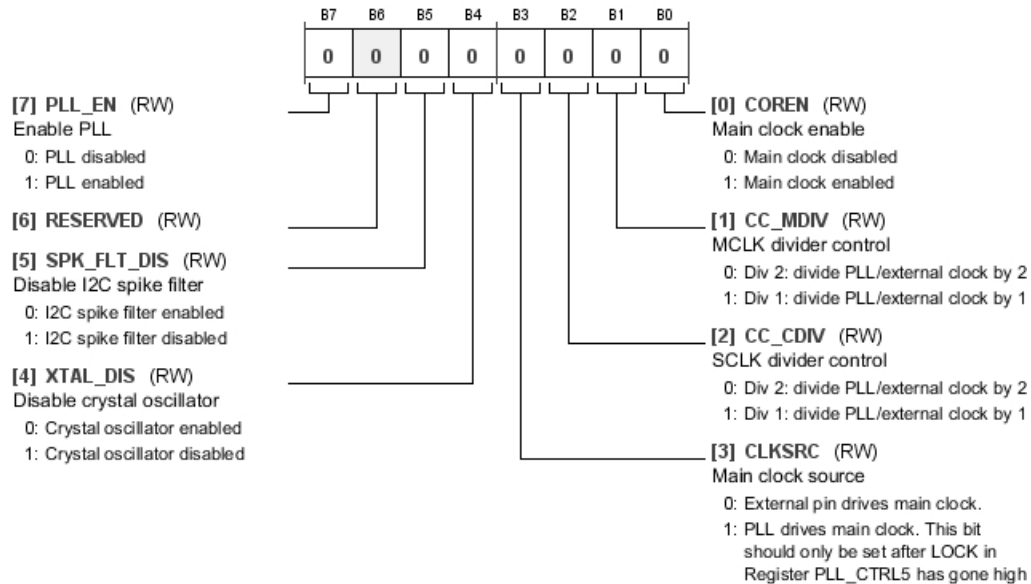

Table 30. Bit Descriptions for CLK\_CONTROL

Bits	Bit Name	Settings	Description	Reset	Access
7	PLL_EN	0 1	Enable PLL. When this bit is set to 0, the PLL is powered down and the PLL output clock is disabled. The PLL should not be enabled until after all the PLL control settings (Register PLL_CTRL0 to Register PLL_CTRL5) have been set. The PLL clock output is active when both PLL_EN = 1 and COREN = 1. 0 PLL disabled 1 PLL enabled	0x0	RW
5	SPK_FLT_DIS	0 1	Disable I <sup>2</sup> C spike filter. By default, the SDA and SCL inputs have a 50 ns spike suppression filter. When the control interface is in SPI mode, this filter is disabled regardless of this setting. 0 I <sup>2</sup> C spike filter enabled 1 I <sup>2</sup> C spike filter disabled	0x0	RW
4	XTAL_DIS	0 1	Disable crystal oscillator. 0 Crystal oscillator enabled 1 Crystal oscillator disabled	0x0	RW
3	CLKSRC	0 1	Main clock source. 0 External pin drives main clock. 1 PLL drives main clock. This bit should only be set after LOCK in Register PLL_CTRL5 has gone high.	0x0	RW
2	CC_CDIV	0 1	SCLK divider control. The core clock (SCLK) is used only by the core. It must run at 12.288 MHz. 0 Div 2: divide PLL/external clock by 2 1 Div 1: divide PLL/external clock by 1	0x0	RW
1	CC_MDIV	0 1	MCLK divider control. The internal master clock (MCLK) of the IC is used by all digital logic except the core. It must run at 12.288 MHz. 0 Div 2: divide PLL/external clock by 2 1 Div 1: divide PLL/external clock by 1	0x0	RW

Bits	Bit Name	Settings	Description	Reset	Access
0	COREN	0 1	Main clock enable. When COREN = 0, it is only possible to write to this register and the PLL control registers (PLL_CTRL0 to PLL_CTRL5). This control also enables the PLL clock. If using the PLL, do not set COREN = 1 until LOCK in Register PLL_CTRL5 is 1. Note that after COREN is enabled, writing to the parameters is disabled until setting DSP_CLK_EN in the CORE_ENABLE register. 0 Main clock disabled 1 Main clock enabled	0x0	RW

**PLL DENOMINATOR MSB REGISTER**

Address: 0x0001, Reset: 0x00, Name: PLL\_CTRL0

This register should only be written when PLL\_EN = 0 in Register CLK\_CONTROL.

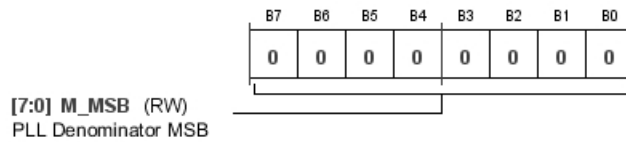

Table 31. Bit Descriptions for PLL\_CTRL0

Bits	Bit Name	Settings	Description	Reset	Access
[7:0]	M_MSB		PLL denominator MSB.	0x00	RW

**PLL DENOMINATOR LSB REGISTER**

Address: 0x0002, Reset: 0x00, Name: PLL\_CTRL1

This register should only be written when PLL\_EN = 0 in Register CLK\_CONTROL.

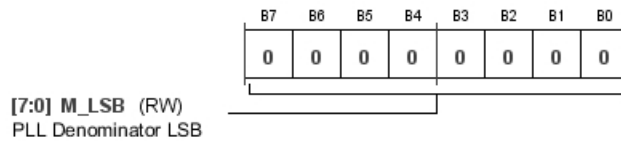

Table 32. Bit Descriptions for PLL\_CTRL1

Bits	Bit Name	Settings	Description	Reset	Access
[7:0]	M_LSB		PLL denominator LSB.	0x00	RW

**PLL NUMERATOR MSB REGISTER**

Address: 0x0003, Reset: 0x00, Name: PLL\_CTRL2

This register should only be written when PLL\_EN = 0 in Register CLK\_CONTROL.

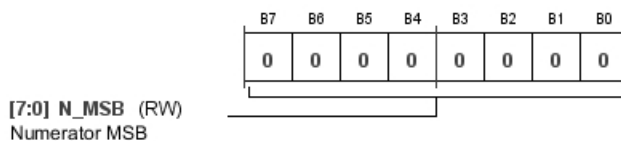

Table 33. Bit Descriptions for PLL\_CTRL2

Bits	Bit Name	Settings	Description	Reset	Access
[7:0]	N_MSB		PLL numerator MSB.	0x00	RW

**PLL NUMERATOR LSB REGISTER**

Address: 0x0004, Reset: 0x00, Name: PLL\_CTRL3

This register should only be written when PLL\_EN = 0 in Register CLK\_CONTROL.

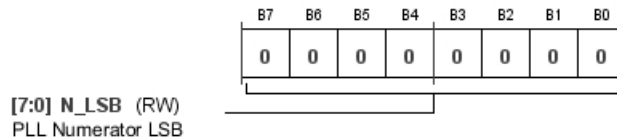

Table 34. Bit Descriptions for PLL\_CTRL3

Bits	Bit Name	Settings	Description	Reset	Access
[7:0]	N_LSB		PLL numerator LSB.	0x00	RW

**PLL INTEGER SETTING REGISTER**

Address: 0x0005, Reset: 0x00, Name: PLL\_CTRL4

This register should only be written when PLL\_EN = 0 in Register CLK\_CONTROL.

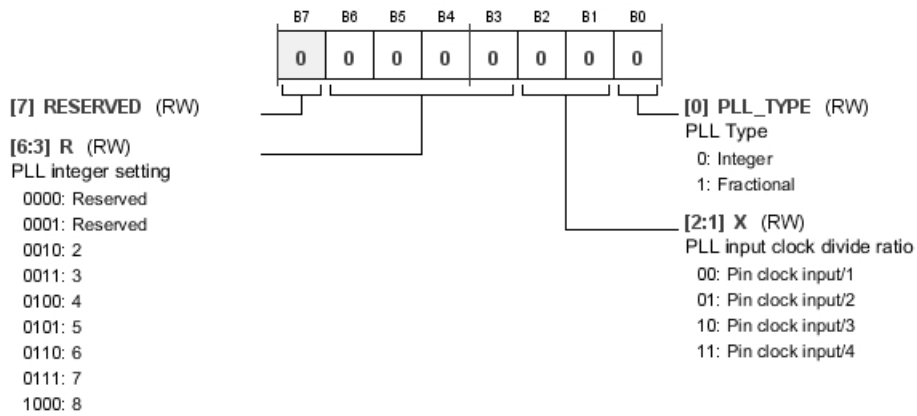

Table 35. Bit Descriptions for PLL\_CTRL4

Bits	Bit Name	Settings	Description	Reset	Access
[6:3]	R		PLL integer setting.	0x0	RW
		0000	Reserved		
		0001	Reserved		
		0010	2		
		0011	3		
		0100	4		
		0101	5		
		0110	6		
		0111	7		
		1000	8		

Bits	Bit Name	Settings	Description	Reset	Access
[2:1]	X	00 01 10 11	PLL input clock divide ratio. Pin clock input/1 Pin clock input/2 Pin clock input/3 Pin clock input/4	0x0	RW
0	PLL_TYPE	0 1	PLL type. Integer Fractional	0x0	RW

**PLL LOCK FLAG REGISTER**

Address: 0x0006, Reset: 0x00, Name: PLL\_CTRL5

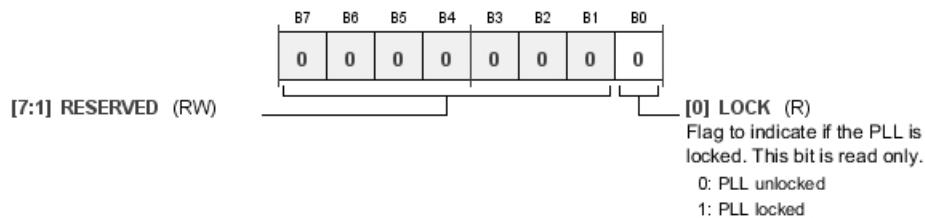

Table 36. Bit Descriptions for PLL\_CTRL5

Bits	Bit Name	Settings	Description	Reset	Access
0	LOCK	0 1	Flag to indicate if the PLL is locked. This bit is read only. PLL unlocked PLL locked	0x0	R

**CLKOUT SETTING SELECTION REGISTER**

Address: 0x0007, Reset: 0x00, Name: CLKOUT\_SEL

When Pin ADC\_SDATA1/CLKOUT/MP6 is set to clock output mode, the frequency of the output clock is set here. CLKOUT can be used to provide a master clock to another IC, the clock for digital microphones, or as the clock for the PDM output stream. The 12 MHz/24 MHz setting is used when clocking another IC, 3 MHz/6 MHz for PDMOUT, and 1.5 MHz/3 MHz when clocking digital microphones. The CLKOUT frequency is derived from the master clock frequency, which is assumed to (and always should) be 12.288 MHz. The 12.288 MHz and 24.576 MHz output modes are not functional if PDM is enabled (Register PDM\_OUT, Bits[1:0]).

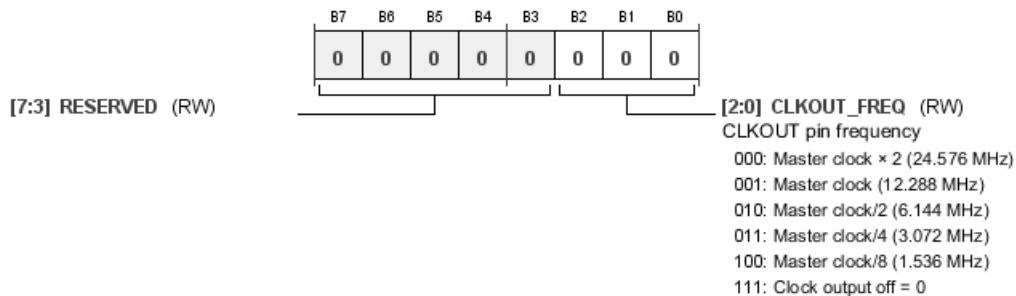

Table 37. Bit Descriptions for CLKOUT\_SEL

Bits	Bit Name	Settings	Description	Reset	Access
[2:0]	CLKOUT_FREQ	000 001 010 011 100 111	CLKOUT pin frequency. Master clock × 2 (24.576 MHz) Master clock (12.288 MHz) Master clock/2 (6.144 MHz) Master clock/4 (3.072 MHz) Master clock/8 (1.536 MHz) Clock output off = 0	0x0	RW

**REGULATOR CONTROL REGISTER**

Address: 0x0008, Reset: 0x00, Name: REGULATOR

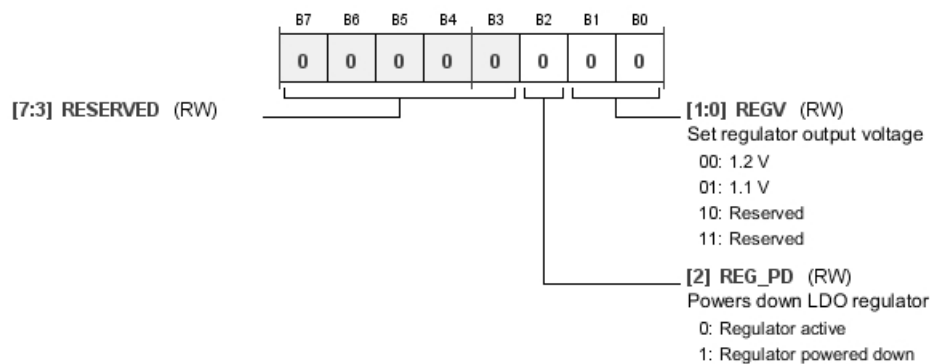

Table 38. Bit Descriptions for REGULATOR

Bits	Bit Name	Settings	Description	Reset	Access
2	REG_PD	0 1	Powers down LDO regulator. Regulator active Regulator powered down	0x0	RW
[1:0]	REGV	00 01 10 11	Set regulator output voltage. 1.2 V 1.1 V Reserved Reserved	0x0	RW

**CORE CONTROL REGISTER**

Address: 0x0009, Reset: 0x04, Name: CORE\_CONTROL

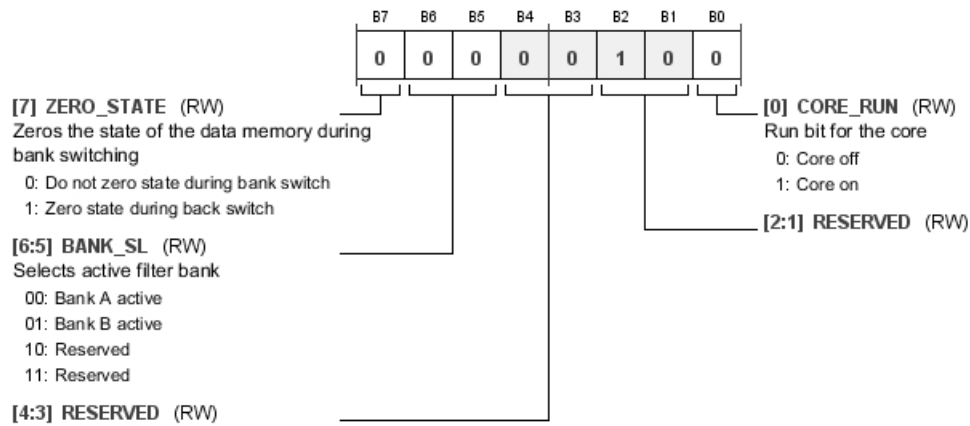

Table 39. Bit Descriptions for CORE\_CONTROL

Bits	Bit Name	Settings	Description	Reset	Access
7	ZERO_STATE	0 1	Zeroes the state of the data memory during bank switching. When switching active parameter banks between two settings, zeroing the state of the bank prevents the new filter settings from being active on old data that is recirculating in filters. Zeroing the state may prevent filter instability or unwanted noises upon bank switching. Do not zero state during bank switch Zero state during back switch	0x0	RW
[6:5]	BANK_SL	00 01 10 11	Selects active filter bank. Bank A active Bank B active Reserved Reserved	0x0	RW
[2:1]	CORE_FS	00 01 10 11	This bit sets the core sample rate. This setting should not be changed while the core is running. CORE_RUN must be set to 0 for this setting to be updated. Reserved 96 kHz 192 kHz Reserved		
0	CORE_RUN	0 1	Run bit for the core. This bit should only be enabled when the program and parameters are loaded and the sample rate settings have been set. CORE_RUN starts and stops the core at the beginning of the program. Core off Core on	0x0	RW

**FILTER ENGINE AND LIMITER CONTROL REGISTER**

Address: 0x000B, Reset: 0x03, Name: CORE\_ENABLE

Disabling the limiter only disables the attack operation. The decay operation is always active, so a limiter can be safely disabled while it performs gain adjustments.

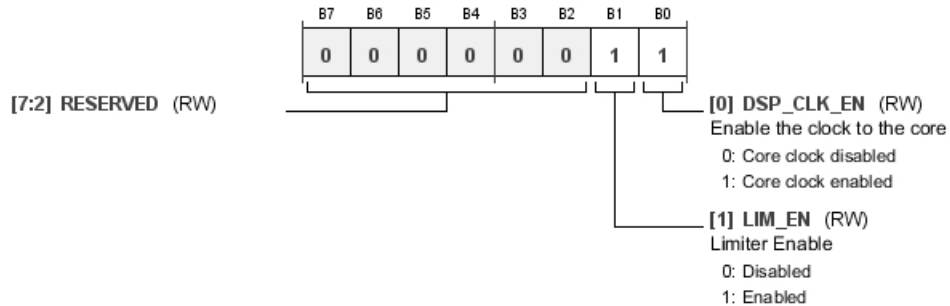

Table 40. Bit Descriptions for CORE\_ENABLE

Bits	Bit Name	Settings	Description	Reset	Access
1	LIM_EN	0 1	Limiter enable. When the limiter function is disabled, a fixed max gain setting is applied to instructions using the limiters. 0 Disabled 1 Enabled	0x1	RW
0	DSP_CLK_EN	0 1	Enable the clock to the core. Directly controls the clock to the core. It should be set to 0 when the chip is used in a codec-only configuration, in which the core is not used. Writing to any of the biquad coefficient registers (Parameter Memory Address 0x0E0 to Address 0x2BF) is blocked until this bit is 1. This bit should not be used to start or stop the core while it is running, because it would immediately start or stop the core clock and not allow the program to finish. Instead, use CORE_RUN in Register CORE_CONTROL to start or stop the core. 0 Core clock disabled 1 Core clock enabled	0x1	RW

**DB VALUE REGISTER 0 READ**

Address: 0x000C, Reset: 0x00, Name: DBREG0

The core can write data to this register, and the data is automatically converted to a level in dB. The most common usage is to determine the rms value of a signal by taking the absolute value, and then performing low-pass filtering and moving the result to the DBREG0 register.

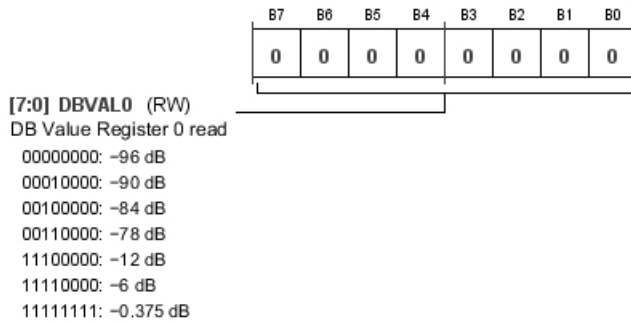

Table 41. Bit Descriptions for DBREG0

Bits	Bit Name	Settings	Description	Reset	Access
[7:0]	DBVAL0	00000000 00010000 00100000 00110000 11100000 11110000 11111111	DB Value Register 0 read. -96 dB -90 dB -84 dB -78 dB -12 dB -6 dB -0.375 dB	0x00	R

**DB VALUE REGISTER 1 READ**

Address: 0x000D, Reset: 0x00, Name: DBREG1

The core can write data to this register, and the data is automatically converted to a level in dB. The most common usage is to determine the rms value of a signal by taking the absolute value, and then performing low-pass filtering and moving the result to the DBREG1 register.

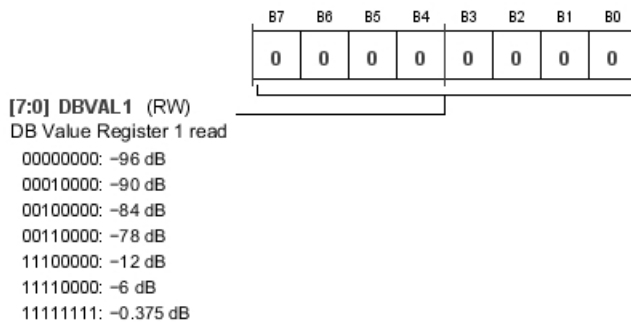

Table 42. Bit Descriptions for DBREG1

Bits	Bit Name	Settings	Description	Reset	Access
[7:0]	DBVAL1	00000000 00010000 00100000 00110000 11100000 11110000 11111111	DB Value Register 1 read. -96 dB -90 dB -84 dB -78 dB -12 dB -6 dB -0.375 dB	0x00	R

**DB VALUE REGISTER 2 READ**

Address: 0x000E, Reset: 0x00, Name: DBREG2

The core can write data to this register, and the data is automatically converted to a level in dB. The most common usage is to determine the rms value of a signal by taking the absolute value, and then performing low-pass filtering and moving the result to the DBREG2 register.

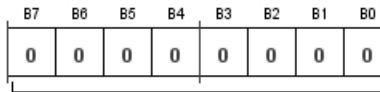

[7:0] DBVAL2 (RW)  
DB Value Register 2 read  
00000000: -96 dB  
00010000: -90 dB  
00100000: -84 dB  
00110000: -78 dB  
11100000: -12 dB  
11110000: -6 dB  
11111111: -0.375 dB

Table 43. Bit Descriptions for DBREG2

Bits	Bit Name	Settings	Description	Reset	Access
[7:0]	DBVAL2	00000000 00010000 00100000 00110000 11100000 11110000 11111111	DB Value Register 2 read. -96 dB -90 dB -84 dB -78 dB -12 dB -6 dB -0.375 dB	0x00	R

**CORE CHANNEL 0/CORE CHANNEL 1 INPUT SELECT REGISTER**

Address: 0x000F, Reset: 0x10, Name: CORE\_IN\_MUX\_0\_1

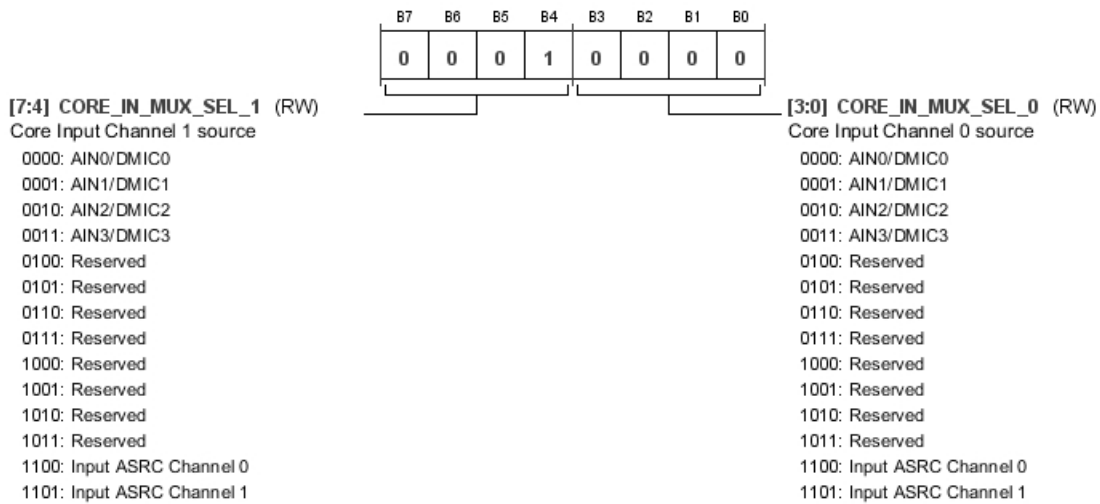

**Table 44. Bit Descriptions for CORE\_IN\_MUX\_0\_1**

Bits	Bit Name	Settings	Description	Reset	Access
[7:4]	CORE_IN_MUX_SEL_1	0000 0001 0010 0011 0100 0101 0110 0111 1000 1001 1010 1011 1100 1101	Core Input Channel 1 source. AIN0/DMIC0 AIN1/DMIC1 AIN2/DMIC2 AIN3/DMIC3 Reserved Reserved Reserved Reserved Reserved Reserved Reserved Reserved Input ASRC Channel 0 Input ASRC Channel 1	0x1	RW
[3:0]	CORE_IN_MUX_SEL_0	0000 0001 0010 0011 0100 0101 0110 0111 1000 1001 1010 1011 1100 1101	Core Input Channel 0 source. AIN0/DMIC0 AIN1/DMIC1 AIN2/DMIC2 AIN3/DMIC3 Reserved Reserved Reserved Reserved Reserved Reserved Reserved Reserved Input ASRC Channel 0 Input ASRC Channel 1	0x0	RW

**CORE CHANNEL 2/CORE CHANNEL 3 INPUT SELECT REGISTER**

Address: 0x0010, Reset: 0x32, Name: CORE\_IN\_MUX\_2\_3

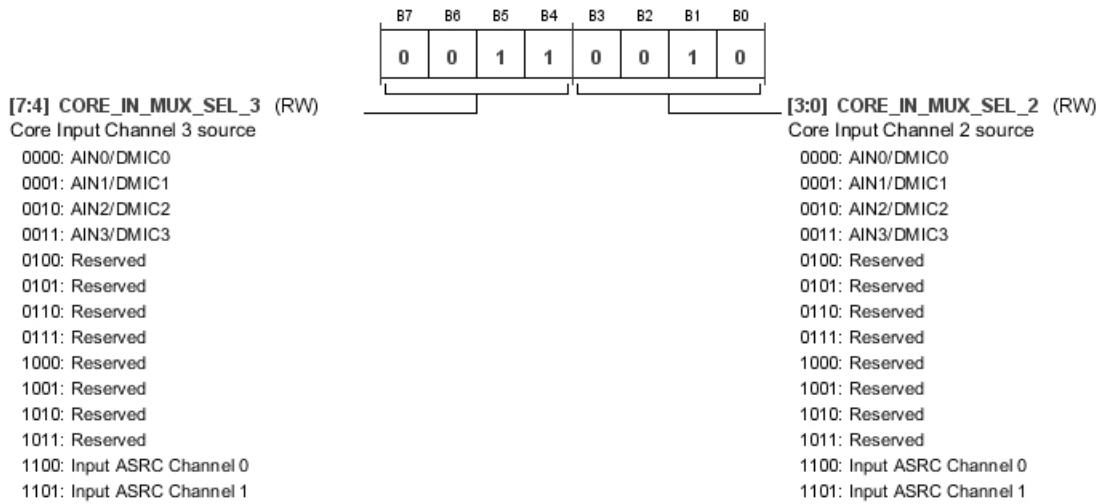
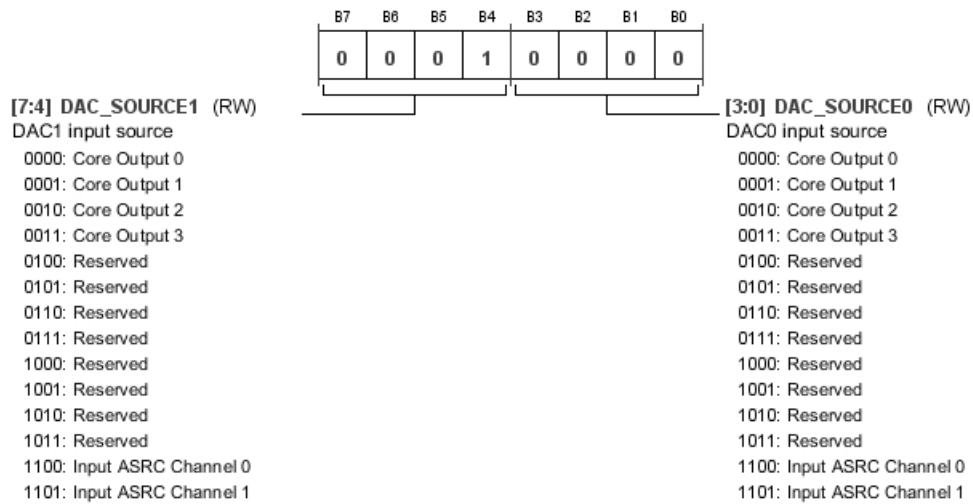

Table 45. Bit Descriptions for CORE\_IN\_MUX\_2\_3

Bits	Bit Name	Settings	Description	Reset	Access
[7:4]	CORE_IN_MUX_SEL_3	0000 0001 0010 0011 0100 0101 0110 0111 1000 1001 1010 1011 1100 1101	Core Input Channel 3 source. AIN0/DMIC0 AIN1/DMIC1 AIN2/DMIC2 AIN3/DMIC3 Reserved Reserved Reserved Reserved Reserved Reserved Reserved Reserved Input ASRC Channel 0 Input ASRC Channel 1	0x3	RW
[3:0]	CORE_IN_MUX_SEL_2	0000 0001 0010 0011 0100 0101 0110 0111 1000 1001 1010 1011 1100 1101	Core Input Channel 2 source. AIN0/DMIC0 AIN1/DMIC1 AIN2/DMIC2 AIN3/DMIC3 Reserved Reserved Reserved Reserved Reserved Reserved Reserved Reserved Input ASRC Channel 0 Input ASRC Channel 1	0x2	RW

**DAC INPUT SELECT REGISTER**

Address: 0x0011, Reset: 0x10, Name: DAC\_SOURCE\_0\_1

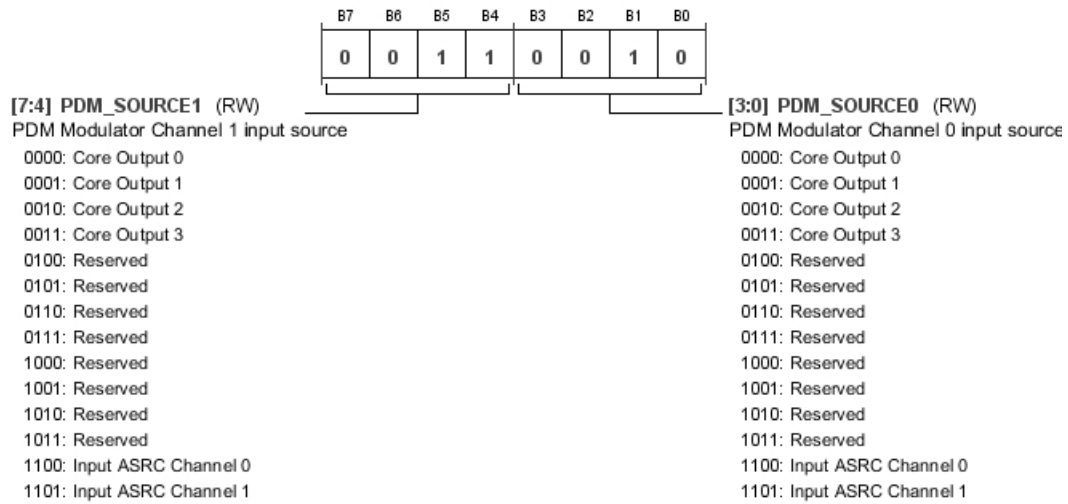

**Table 46. Bit Descriptions for DAC\_SOURCE\_0\_1**

Bits	Bit Name	Settings	Description	Reset	Access
[7:4]	DAC_SOURCE1	0000 0001 0010 0011 0100 0101 0110 0111 1000 1001 1010 1011 1100 1101	DAC1 input source. This setting should not be changed while the core is running. CORE_RUN must be set to 0 for this setting to be updated. Core Output 0 Core Output 1 Core Output 2 Core Output 3 Reserved Reserved Reserved Reserved Reserved Reserved Reserved Reserved Input ASRC Channel 0 Input ASRC Channel 1	0x1	RW
[3:0]	DAC_SOURCE0	0000 0001 0010 0011 0100 0101 0110 0111 1000 1001 1010 1011 1100 1101	DAC0 input source. This setting should not be changed while the core is running. CORE_RUN must be set to 0 for this setting to be updated. Core Output 0 Core Output 1 Core Output 2 Core Output 3 Reserved Reserved Reserved Reserved Reserved Reserved Reserved Reserved Input ASRC Channel 0 Input ASRC Channel 1	0x0	RW

**PDM MODULATOR INPUT SELECT REGISTER**

Address: 0x0012, Reset: 0x32, Name: PDM\_SOURCE\_0\_1

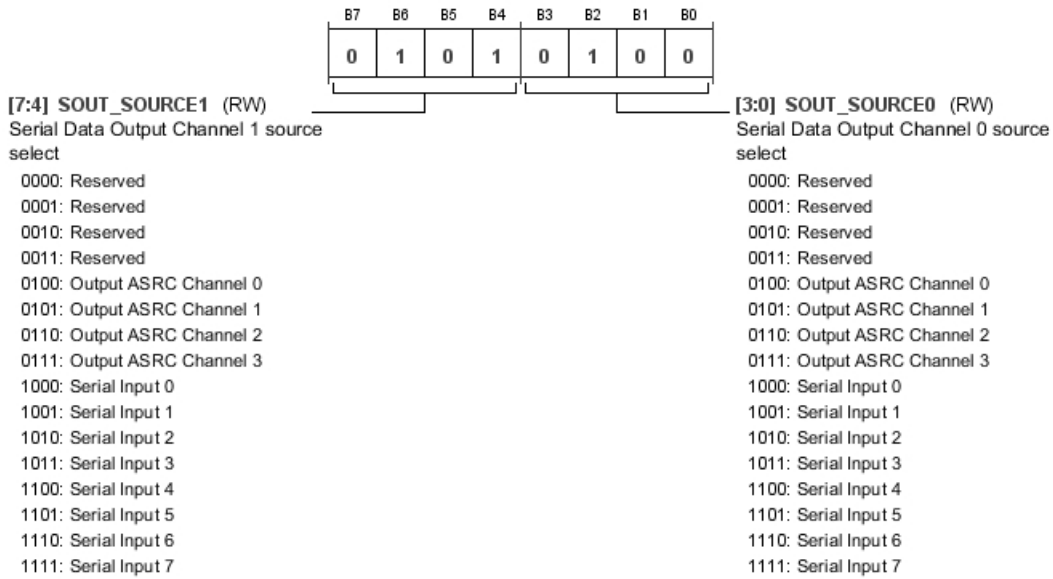

**Table 47. Bit Descriptions for PDM\_SOURCE\_0\_1**

Bits	Bit Name	Settings	Description	Reset	Access
[7:4]	PDM_SOURCE1	<ul style="list-style-type: none"> <li>0000</li> <li>0001</li> <li>0010</li> <li>0011</li> <li>0100</li> <li>0101</li> <li>0110</li> <li>0111</li> <li>1000</li> <li>1001</li> <li>1010</li> <li>1011</li> <li>1100</li> <li>1101</li> </ul>	PDM Modulator Channel 1 input source.  Core Output 0 Core Output 1 Core Output 2 Core Output 3 Reserved Reserved Reserved Reserved Reserved Reserved Reserved Reserved Input ASRC Channel 0 Input ASRC Channel 1	0x3	RW
[3:0]	PDM_SOURCE0	<ul style="list-style-type: none"> <li>0000</li> <li>0001</li> <li>0010</li> <li>0011</li> <li>0100</li> <li>0101</li> <li>0110</li> <li>0111</li> <li>1000</li> <li>1001</li> <li>1010</li> <li>1011</li> <li>1100</li> <li>1101</li> </ul>	PDM Modulator Channel 0 input source.  Core Output 0 Core Output 1 Core Output 2 Core Output 3 Reserved Reserved Reserved Reserved Reserved Reserved Reserved Input ASRC Channel 0 Input ASRC Channel 1	0x2	RW

**SERIAL DATA OUTPUT 0/SERIAL DATA OUTPUT 1 INPUT SELECT REGISTER**

Address: 0x0013, Reset: 0x54, Name: SOUT\_SOURCE\_0\_1



**Table 48. Bit Descriptions for SOUT\_SOURCE\_0\_1**

Bits	Bit Name	Settings	Description	Reset	Access
[7:4]	SOUT_SOURCE1	0000 0001 0010 0011 0100 0101 0110 0111 1000 1001 1010 1011 1100 1101 1110 1111	Serial Data Output Channel 1 source select. Reserved Reserved Reserved Reserved Output ASRC Channel 0 Output ASRC Channel 1 Output ASRC Channel 2 Output ASRC Channel 3 Serial Input 0 Serial Input 1 Serial Input 2 Serial Input 3 Serial Input 4 Serial Input 5 Serial Input 6 Serial Input 7	0x5	RW
[3:0]	SOUT_SOURCE0	0000 0001 0010 0011 0100 0101 0110 0111 1000 1001 1010	Serial Data Output Channel 0 source select. Reserved Reserved Reserved Reserved Output ASRC Channel 0 Output ASRC Channel 1 Output ASRC Channel 2 Output ASRC Channel 3 Serial Input 0 Serial Input 1 Serial Input 2	0x4	RW

Bits	Bit Name	Settings	Description	Reset	Access
		1011	Serial Input 3		
		1100	Serial Input 4		
		1101	Serial Input 5		
		1110	Serial Input 6		
		1111	Serial Input 7		

**SERIAL DATA OUTPUT 2/SERIAL DATA OUTPUT 3 INPUT SELECT REGISTER**

Address: 0x0014, Reset: 0x76, Name: SOUT\_SOURCE\_2\_3

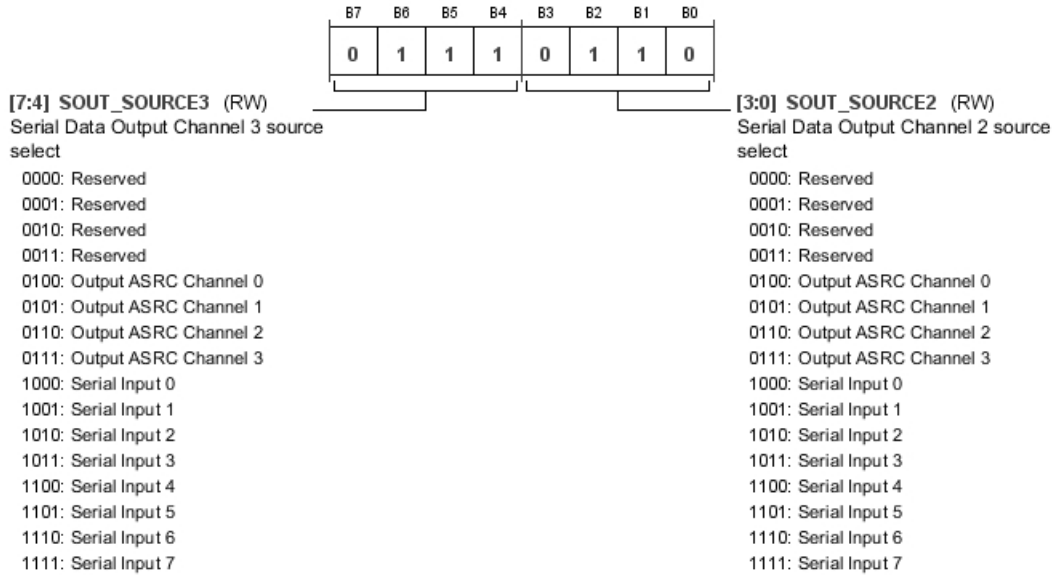

**Table 49. Bit Descriptions for SOUT\_SOURCE\_2\_3**

Bits	Bit Name	Settings	Description	Reset	Access
[7:4]	SOUT_SOURCE3		Serial Data Output Channel 3 source select.	0x7	RW
		0000	Reserved		
		0001	Reserved		
		0010	Reserved		
		0011	Reserved		
		0100	Output ASRC Channel 0		
		0101	Output ASRC Channel 1		
		0110	Output ASRC Channel 2		
		0111	Output ASRC Channel 3		
		1000	Serial Input 0		
		1001	Serial Input 1		
		1010	Serial Input 2		
		1011	Serial Input 3		
		1100	Serial Input 4		
		1101	Serial Input 5		
		1110	Serial Input 6		
		1111	Serial Input 7		
[3:0]	SOUT_SOURCE2		Serial Data Output Channel 2 source select.	0x6	RW
		0000	Reserved		
		0001	Reserved		
		0010	Reserved		

Bits	Bit Name	Settings	Description	Reset	Access
		0011	Reserved		
		0100	Output ASRC Channel 0		
		0101	Output ASRC Channel 1		
		0110	Output ASRC Channel 2		
		0111	Output ASRC Channel 3		
		1000	Serial Input 0		
		1001	Serial Input 1		
		1010	Serial Input 2		
		1011	Serial Input 3		
		1100	Serial Input 4		
		1101	Serial Input 5		
		1110	Serial Input 6		
		1111	Serial Input 7		

**SERIAL DATA OUTPUT 4/SERIAL DATA OUTPUT 5 INPUT SELECT REGISTER**

Address: 0x0015, Reset: 0x54, Name: SOUT\_SOURCE\_4\_5

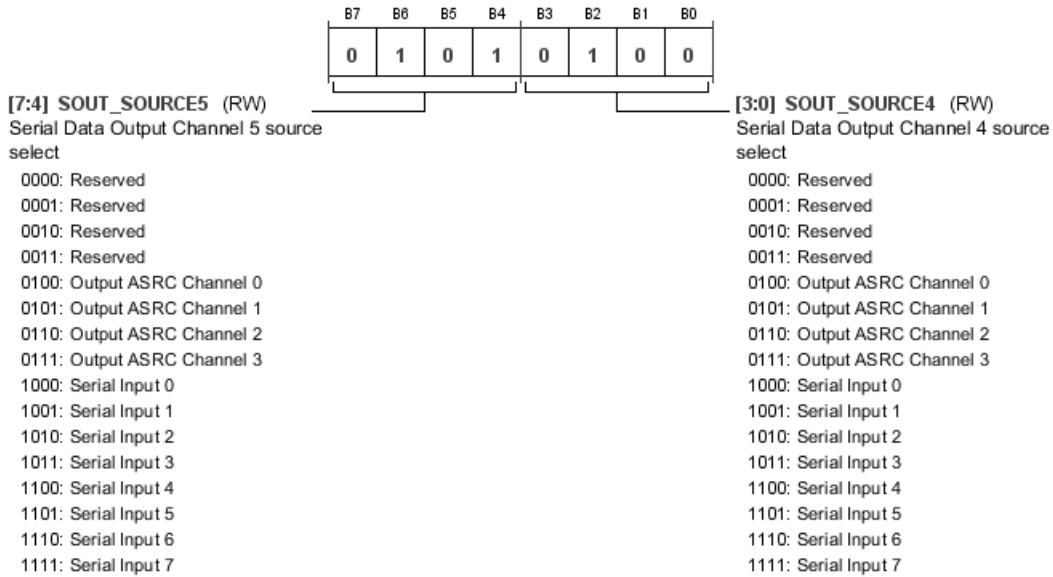

**Table 50. Bit Descriptions for SOUT\_SOURCE\_4\_5**

Bits	Bit Name	Settings	Description	Reset	Access
[7:4]	SOUT_SOURCE5		Serial Data Output Channel 5 source select.	0x5	RW
		0000	Reserved		
		0001	Reserved		
		0010	Reserved		
		0011	Reserved		
		0100	Output ASRC Channel 0		
		0101	Output ASRC Channel 1		
		0110	Output ASRC Channel 2		
		0111	Output ASRC Channel 3		
		1000	Serial Input 0		
		1001	Serial Input 1		
		1010	Serial Input 2		
		1011	Serial Input 3		

Bits	Bit Name	Settings	Description	Reset	Access
		1100	Serial Input 4		
		1101	Serial Input 5		
		1110	Serial Input 6		
		1111	Serial Input 7		
[3:0]	SOUT_SOURCE4		Serial Data Output Channel 4 source select.	0x4	RW
		0000	Reserved		
		0001	Reserved		
		0010	Reserved		
		0011	Reserved		
		0100	Output ASRC Channel 0		
		0101	Output ASRC Channel 1		
		0110	Output ASRC Channel 2		
		0111	Output ASRC Channel 3		
		1000	Serial Input 0		
		1001	Serial Input 1		
		1010	Serial Input 2		
		1011	Serial Input 3		
		1100	Serial Input 4		
		1101	Serial Input 5		
		1110	Serial Input 6		
		1111	Serial Input 7		

**SERIAL DATA OUTPUT 6/SERIAL DATA OUTPUT 7 INPUT SELECT REGISTER**

Address: 0x0016, Reset: 0x76, Name: SOUT\_SOURCE\_6\_7

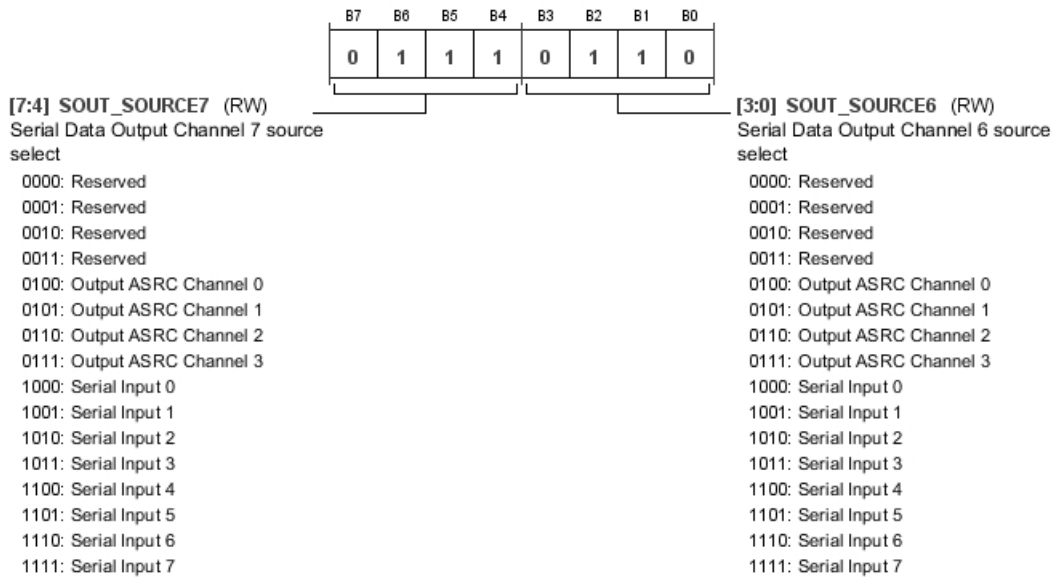

Table 51. Bit Descriptions for SOUT\_SOURCE\_6\_7

Bits	Bit Name	Settings	Description	Reset	Access
[7:4]	SOUT_SOURCE7		Serial Data Output Channel 7 source select.	0x7	RW
		0000	Reserved		
		0001	Reserved		
		0010	Reserved		
		0011	Reserved		

Bits	Bit Name	Settings	Description	Reset	Access
		0100	Output ASRC Channel 0		
		0101	Output ASRC Channel 1		
		0110	Output ASRC Channel 2		
		0111	Output ASRC Channel 3		
		1000	Serial Input 0		
		1001	Serial Input 1		
		1010	Serial Input 2		
		1011	Serial Input 3		
		1100	Serial Input 4		
		1101	Serial Input 5		
		1110	Serial Input 6		
		1111	Serial Input 7		
[3:0]	SOUT_SOURCE6		Serial Data Output Channel 6 source select.	0x6	RW
		0000	Reserved		
		0001	Reserved		
		0010	Reserved		
		0011	Reserved		
		0100	Output ASRC Channel 0		
		0101	Output ASRC Channel 1		
		0110	Output ASRC Channel 2		
		0111	Output ASRC Channel 3		
		1000	Serial Input 0		
		1001	Serial Input 1		
		1010	Serial Input 2		
		1011	Serial Input 3		
		1100	Serial Input 4		
		1101	Serial Input 5		
		1110	Serial Input 6		
		1111	Serial Input 7		

**ADC\_SDATA0/ADC\_SDATA1 CHANNEL SELECT REGISTER**

Address: 0x0017, Reset: 0x04, Name: ADC\_SDATA\_CH

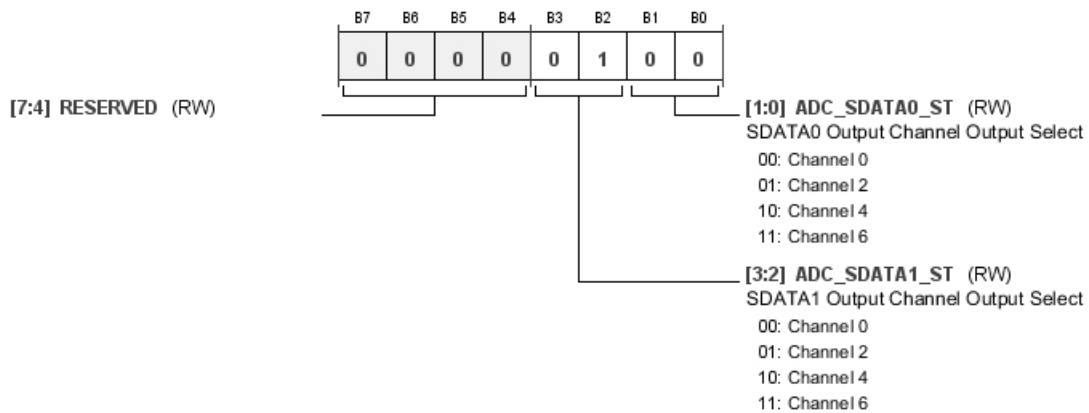

Table 52. Bit Descriptions for ADC\_SDATA\_CH

Bits	Bit Name	Settings	Description	Reset	Access
[3:2]	ADC_SDATA1_ST	00 01 10 11	SDATA1 output channel output select. Selects the output channel at which ADC_SDATA1 starts to output data. The output port sequentially outputs data following this start channel according to the setting of Bit SAI. Channel 0 Channel 2 Channel 4 Channel 6	0x1	RW
[1:0]	ADC_SDATA0_ST	00 01 10 11	SDATA0 output channel output select. Selects the output channel at which ADC_SDATA0 starts to output data. The output port sequentially outputs data following this start channel according to the setting of Bit SAI. Channel 0 Channel 2 Channel 4 Channel 6	0x0	RW

**OUTPUT ASRC0/OUTPUT ASRC1 SOURCE REGISTER**

Address: 0x0018, Reset: 0x10, Name: ASRCO\_SOURCE\_0\_1

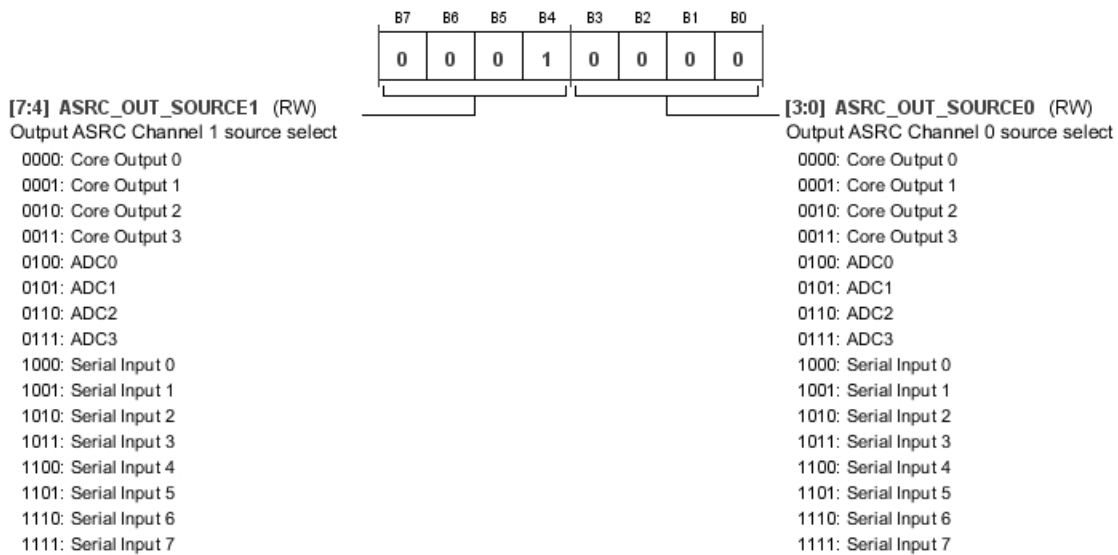

Table 53. Bit Descriptions for ASRCO\_SOURCE\_0\_1

Bits	Bit Name	Settings	Description	Reset	Access
[7:4]	ASRC_OUT_SOURCE1	0000 0001 0010 0011 0100 0101 0110 0111 1000 1001 1010	Output ASRC Channel 1 source select. Core Output 0 Core Output 1 Core Output 2 Core Output 3 ADC0 ADC1 ADC2 ADC3 Serial Input 0 Serial Input 1 Serial Input 2	0x1	RW

Bits	Bit Name	Settings	Description	Reset	Access
		1011	Serial Input 3		
		1100	Serial Input 4		
		1101	Serial Input 5		
		1110	Serial Input 6		
		1111	Serial Input 7		
[3:0]	ASRC_OUT_SOURCE0		Output ASRC Channel 0 source select.	0x0	RW
		0000	Core Output 0		
		0001	Core Output 1		
		0010	Core Output 2		
		0011	Core Output 3		
		0100	ADC0		
		0101	ADC1		
		0110	ADC2		
		0111	ADC3		
		1000	Serial Input 0		
		1001	Serial Input 1		
		1010	Serial Input 2		
		1011	Serial Input 3		
		1100	Serial Input 4		
		1101	Serial Input 5		
		1110	Serial Input 6		
		1111	Serial Input 7		

**OUTPUT ASRC2/OUTPUT ASRC3 SOURCE REGISTER**

Address: 0x0019, Reset: 0x32, Name: ASRCO\_SOURCE\_2\_3



**[7:4] ASRC\_OUT\_SOURCE3 (RW)**  
 Output ASRC Channel 3 source select

- 0000: Core Output 0
- 0001: Core Output 1
- 0010: Core Output 2
- 0011: Core Output 3
- 0100: ADC0
- 0101: ADC1
- 0110: ADC2
- 0111: ADC3
- 1000: Serial Input 0
- 1001: Serial Input 1
- 1010: Serial Input 2
- 1011: Serial Input 3
- 1100: Serial Input 4
- 1101: Serial Input 5
- 1110: Serial Input 6
- 1111: Serial Input 7

**[3:0] ASRC\_OUT\_SOURCE2 (RW)**  
 Output ASRC Channel 2 source select

- 0000: Core Output 0
- 0001: Core Output 1
- 0010: Core Output 2
- 0011: Core Output 3
- 0100: ADC0
- 0101: ADC1
- 0110: ADC2
- 0111: ADC3
- 1000: Serial Input 0
- 1001: Serial Input 1
- 1010: Serial Input 2
- 1011: Serial Input 3
- 1100: Serial Input 4
- 1101: Serial Input 5
- 1110: Serial Input 6
- 1111: Serial Input 7

**Table 54. Bit Descriptions for ASRCO\_SOURCE\_2\_3**

Bits	Bit Name	Settings	Description	Reset	Access
[7:4]	ASRC_OUT_SOURCE3		Output ASRC Channel 3 source select.	0x3	RW
		0000	Core Output 0		
		0001	Core Output 1		
		0010	Core Output 2		
		0011	Core Output 3		

Bits	Bit Name	Settings	Description	Reset	Access
		0100	ADC0		
		0101	ADC1		
		0110	ADC2		
		0111	ADC3		
		1000	Serial Input 0		
		1001	Serial Input 1		
		1010	Serial Input 2		
		1011	Serial Input 3		
		1100	Serial Input 4		
		1101	Serial Input 5		
		1110	Serial Input 6		
		1111	Serial Input 7		
[3:0]	ASRC_OUT_SOURCE2	0000	Core Output 0	0x2	RW
		0001	Core Output 1		
		0010	Core Output 2		
		0011	Core Output 3		
		0100	ADC0		
		0101	ADC1		
		0110	ADC2		
		0111	ADC3		
		1000	Serial Input 0		
		1001	Serial Input 1		
		1010	Serial Input 2		
		1011	Serial Input 3		
		1100	Serial Input 4		
		1101	Serial Input 5		
		1110	Serial Input 6		
		1111	Serial Input 7		

**INPUT ASRC CHANNEL SELECT REGISTER**

Address: 0x001A, Reset: 0x00, Name: ASRC\_MODE

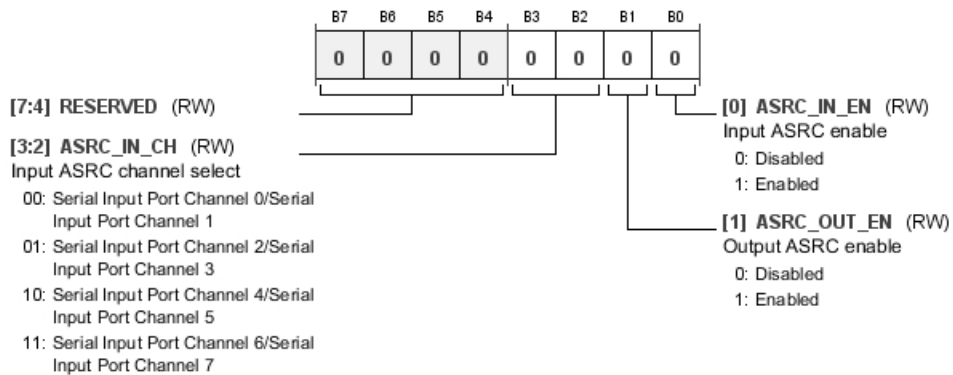

Table 55. Bit Descriptions for ASRC\_MODE

Bits	Bit Name	Settings	Description	Reset	Access
[3:2]	ASRC_IN_CH	00	Serial Input Port Channel 0/Serial Input Port Channel 1	0x0	RW
		01	Serial Input Port Channel 2/Serial Input Port Channel 3		

Bits	Bit Name	Settings	Description	Reset	Access
		10	Serial Input Port Channel 4/Serial Input Port Channel 5		
		11	Serial Input Port Channel 6/Serial Input Port Channel 7		
1	ASRC_OUT_EN	0 1	Output ASRC enable. Disabled Enabled	0x0	RW
0	ASRC_IN_EN	0 1	Input ASRC enable. Disabled Enabled	0x0	RW

**ADC0/ADC1 CONTROL 0 REGISTER**

Address: 0x001B, Reset: 0x19, Name: ADC\_CONTROL0

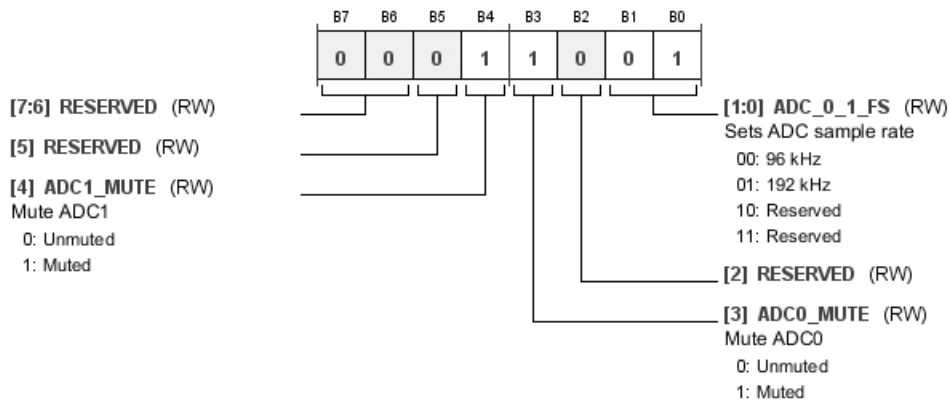

Table 56. Bit Descriptions for ADC\_CONTROL0

Bits	Bit Name	Settings	Description	Reset	Access
4	ADC1_MUTE	0 1	Mute ADC1. Muting is accomplished by setting the volume control to maximum attenuation. This bit has no effect if volume control is bypassed. Unmuted Muted	0x1	RW
3	ADC0_MUTE	0 1	Mute ADC0. Muting is accomplished by setting the volume control to maximum attenuation. This bit has no effect if volume control is bypassed. Unmuted Muted	0x1	RW
[1:0]	ADC_0_1_FS	00 01 10 11	Sets ADC sample rate. 96 kHz 192 kHz Reserved Reserved	0x1	RW

**ADC2/ADC3 CONTROL 0 REGISTER**

Address: 0x001C, Reset: 0x19, Name: ADC\_CONTROL1

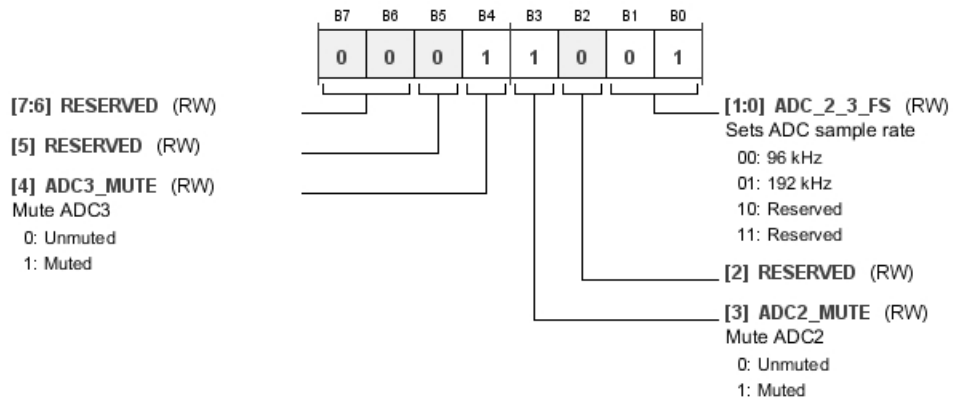
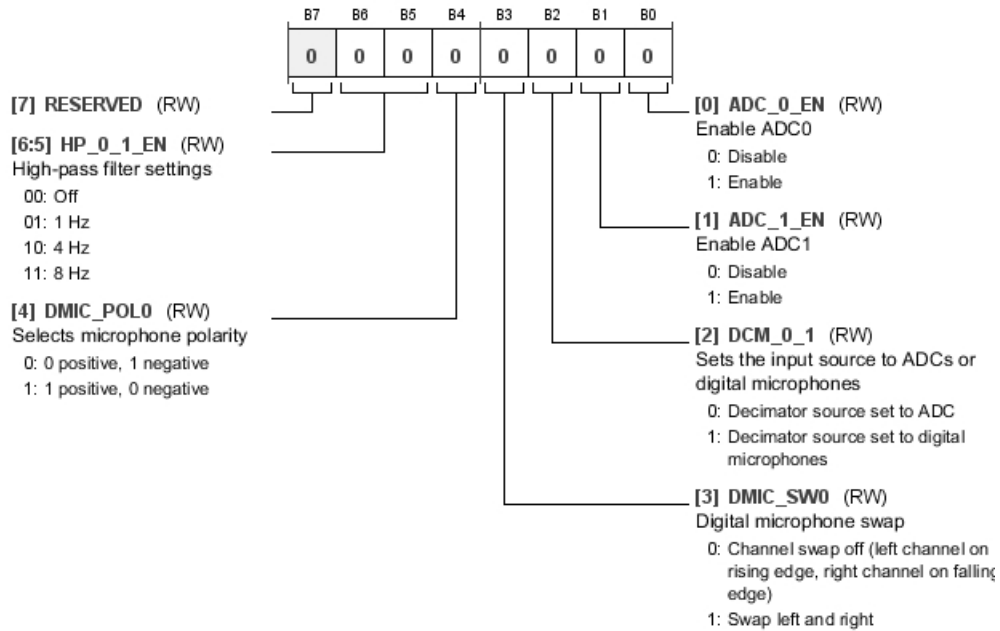

Table 57. Bit Descriptions for ADC\_CONTROL1

Bits	Bit Name	Settings	Description	Reset	Access
4	ADC3_MUTE	0 1	Mute ADC3. Unmuted Muted	0x1	RW
3	ADC2_MUTE	0 1	Mute ADC2. Muting is accomplished by setting the volume control to maximum attenuation. This bit has no effect if volume control is bypassed. Unmuted Muted	0x1	RW
[1:0]	ADC_2_3_FS	00 01 10 11	Sets ADC sample rate. 96 kHz 192 kHz Reserved Reserved	0x1	RW

**ADC0/ADC1 CONTROL 1 REGISTER**

Address: 0x001D, Reset: 0x00, Name: ADC\_CONTROL2



**Table 58. Bit Descriptions for ADC\_CONTROL2**

Bits	Bit Name	Settings	Description	Reset	Access
[6:5]	HP_0_1_EN	00 01 10 11	High-pass filter settings. Off 1 Hz 4 Hz 8 Hz	0x0	RW
4	DMIC_POLO	0 1	Selects microphone polarity. 0 positive, 1 negative 1 positive, 0 negative	0x0	RW
3	DMIC_SW0	0 1	Digital microphone swap. Channel swap off (left channel on rising edge, right channel on falling edge) Swap left and right	0x0	RW
2	DCM_0_1	0 1	Sets the input source to ADCs or digital microphones. Decimator source set to ADC Decimator source set to digital microphones	0x0	RW
1	ADC_1_EN	0 1	Enable ADC1. This bit must be set in conjunction with the SINC_1_EN bit in the DECIM_PWR_MODES register to fully enable or disable the ADC. Disable Enable	0x0	RW
0	ADC_0_EN	0 1	Enable ADC0. This bit must be set in conjunction with the SINC_0_EN bit in the DECIM_PWR_MODES register to fully enable or disable the ADC. Disable Enable	0x0	RW

**ADC2/ADC3 CONTROL 1 REGISTER**

Address: 0x001E, Reset: 0x00, Name: ADC\_CONTROL3

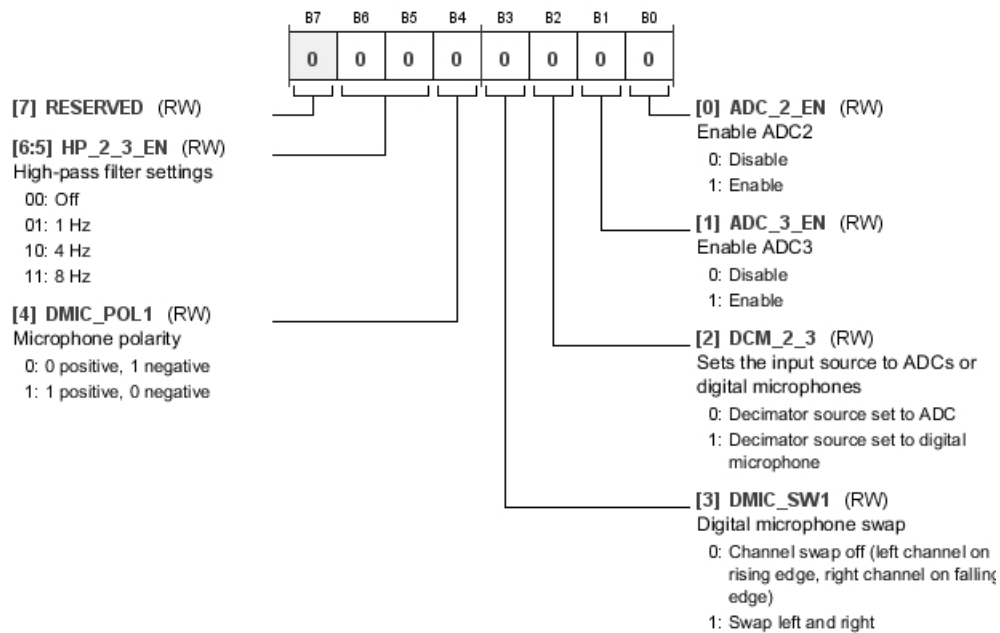

Table 59. Bit Descriptions for ADC\_CONTROL3

Bits	Bit Name	Settings	Description	Reset	Access
[6:5]	HP_2_3_EN	00 01 10 11	High-pass filter settings. Off 1 Hz 4 Hz 8 Hz	0x0	RW
4	DMIC_POL1	0 1	Microphone polarity. 0 positive, 1 negative 1 positive, 0 negative	0x0	RW
3	DMIC_SW1	0 1	Digital microphone swap. Channel swap off (left channel on rising edge, right channel on falling edge) Swap left and right	0x0	RW
2	DCM_2_3	0 1	Sets the input source to ADCs or digital microphones. Decimator source set to ADC Decimator source set to digital microphone	0x0	RW
1	ADC_3_EN	0 1	Enable ADC3. This bit must be set in conjunction with the SINC_3_EN bit in the DECIM_PWR_MODES register to fully enable or disable the ADC. Disable Enable	0x0	RW
0	ADC_2_EN	0 1	Enable ADC2. This bit must be set in conjunction with the SINC_2_EN bit in the DECIM_PWR_MODES register to fully enable or disable the ADC. Disable Enable	0x0	RW

**ADC0 VOLUME CONTROL REGISTER**

Address: 0x001F, Reset: 0x00, Name: ADC0\_VOLUME

When SINC\_0\_EN is set, the volume starts to ramp from -95.625 dB to the value in this register. The volume ramp time is (number of steps) × 16/fs, where there are 256 steps between 0 dB and -95.625 dB. For example, with fs = 192 kHz, the volume ramps from -95.625 dB to 0 dB in 21 ms.

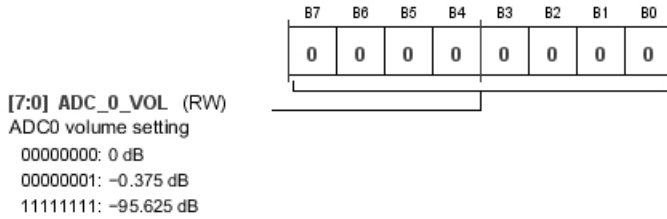

Table 60. Bit Descriptions for ADC0\_VOLUME

Bits	Bit Name	Settings	Description	Reset	Access
[7:0]	ADC_0_VOL	00000000 00000001 11111111	ADC0 volume setting. 0 dB -0.375 dB -95.625 dB	0x00	RW

**ADC1 VOLUME CONTROL REGISTER**

Address: 0x0020, Reset: 0x00, Name: ADC1\_VOLUME

When SINC\_1\_EN is set, the volume starts to ramp from -95.625 dB to the value in this register. The volume ramp time is (number of steps) × 16/fs, where there are 256 steps between 0 dB and -95.625 dB. For example, with fs = 192 kHz, the volume ramps from -95.625 dB to 0 dB in 21 ms.

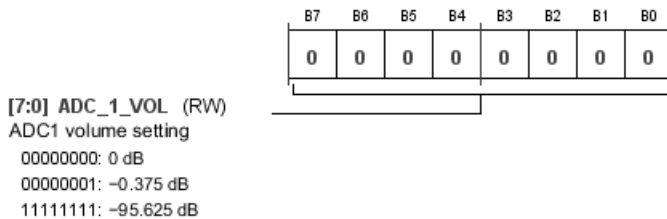
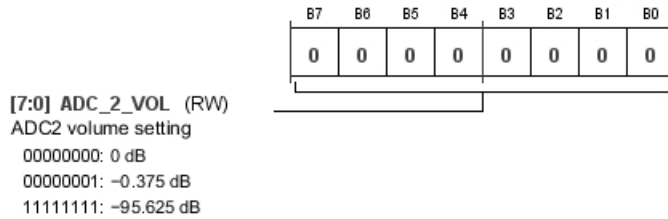

Table 61. Bit Descriptions for ADC1\_VOLUME

Bits	Bit Name	Settings	Description	Reset	Access
[7:0]	ADC_1_VOL	00000000 00000001 11111111	ADC1 volume setting. 0 dB -0.375 dB -95.625 dB	0x00	RW

**ADC2 VOLUME CONTROL REGISTER****Address: 0x0021, Reset: 0x00, Name: ADC2\_VOLUME**

When SINC\_2\_EN is set, the volume starts to ramp from –95.625 dB to the value in this register. The volume ramp time is (number of steps)  $\times$  16/ $f_s$ , where there are 256 steps between 0 dB and –95.625 dB. For example, with  $f_s = 192$  kHz, the volume ramps from –95.625 dB to 0 dB in 21 ms.

**Table 62. Bit Descriptions for ADC2\_VOLUME**

Bits	Bit Name	Settings	Description	Reset	Access
[7:0]	ADC_2_VOL	00000000 00000001 11111111	ADC2 volume setting. 0 dB –0.375 dB –95.625 dB	0x00	RW

**ADC3 VOLUME CONTROL REGISTER****Address: 0x0022, Reset: 0x00, Name: ADC3\_VOLUME**

When SINC\_3\_EN is set, the volume starts to ramp from –95.625 dB to the value in this register. The volume ramp time is (number of steps)  $\times$  16/ $f_s$ , where there are 256 steps between 0 dB and –95.625 dB. For example, with  $f_s = 192$  kHz, the volume ramps from –95.625 dB to 0 dB in 21 ms.

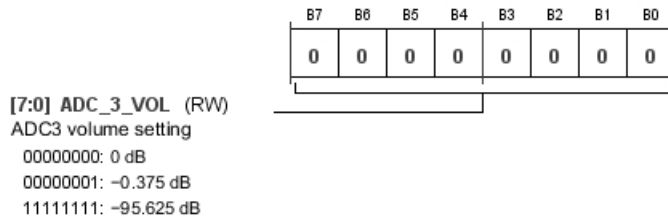
**Table 63. Bit Descriptions for ADC3\_VOLUME**

Bits	Bit Name	Settings	Description	Reset	Access
[7:0]	ADC_3_VOL	00000000 00000001 11111111	ADC3 volume setting. 0 dB –0.375 dB –95.625 dB	0x00	RW

**PGA CONTROL 0 REGISTER**

Address: 0x0023, Reset: 0x40, Name: PGA\_CONTROL\_0

This register controls the PGA connected to AIN0.

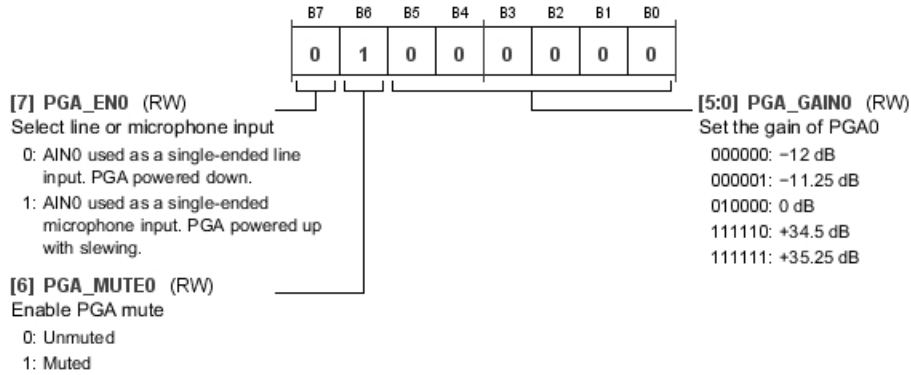

Table 64. Bit Descriptions for PGA\_CONTROL\_0

Bits	Bit Name	Settings	Description	Reset	Access
7	PGA_EN0	0 1	Select line or microphone input. Note that the PGA inverts the signal going through it. 0 AIN0 used as a single-ended line input. PGA powered down. 1 AIN0 used as a single-ended microphone input. PGA powered up with slewing.	0x0	RW
6	PGA_MUTE0	0 1	Enable PGA mute. When PGA is muted, PGA_GAIN0 is ignored. 0 Unmuted 1 Muted	0x1	RW
[5:0]	PGA_GAIN0	000000 000001 010000 111110 111111	Set the gain of PGA0. -12 dB -11.25 dB 0 dB +34.5 dB +35.25 dB	0x0	RW

**PGA CONTROL 1 REGISTER**

Address: 0x0024, Reset: 0x40, Name: PGA\_CONTROL\_1

This register controls the PGA connected to AIN1.

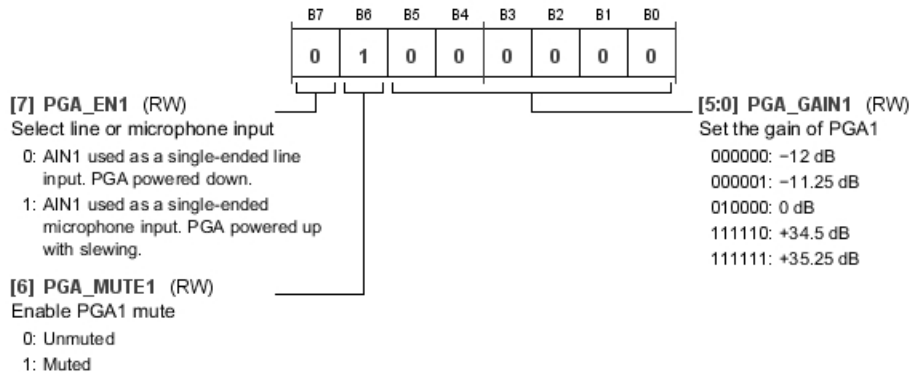

Table 65. Bit Descriptions for PGA\_CONTROL\_1

Bits	Bit Name	Settings	Description	Reset	Access
7	PGA_EN1	0 1	Select line or microphone input. Note that the PGA inverts the signal going through it. 0 AIN1 used as a single-ended line input. PGA powered down. 1 AIN1 used as a single-ended microphone input. PGA powered up with slewing.	0x0	RW
6	PGA_MUTE1	0 1	Enable PGA1 mute. When PGA is muted, PGA_GAIN1 is ignored. 0 Unmuted 1 Muted	0x1	RW
[5:0]	PGA_GAIN1	000000 000001 010000 111110 111111	Set the gain of PGA1. -12 dB -11.25 dB 0 dB +34.5 dB +35.25 dB	0x0	RW

**PGA CONTROL 2 REGISTER**

Address: 0x0025, Reset: 0x40, Name: PGA\_CONTROL\_2

This register controls the PGA connected to AIN2.

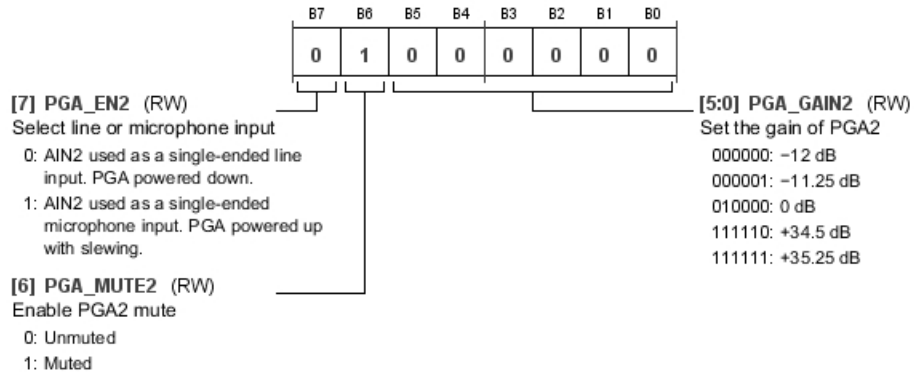

Table 66. Bit Descriptions for PGA\_CONTROL\_2

Bits	Bit Name	Settings	Description	Reset	Access
7	PGA_EN2	0 1	Select line or microphone input. Note that the PGA inverts the signal going through it. 0 AIN2 used as a single-ended line input. PGA powered down. 1 AIN2 used as a single-ended microphone input. PGA powered up with slewing.	0x0	RW
6	PGA_MUTE2	0 1	Enable PGA2 mute. When PGA is muted, PGA_GAIN2 is ignored. 0 Unmuted 1 Muted	0x1	RW
[5:0]	PGA_GAIN2	000000 000001 010000 111110 111111	Set the gain of PGA2. -12 dB -11.25 dB 0 dB +34.5 dB +35.25 dB	0x0	RW

**PGA CONTROL 3 REGISTER**

Address: 0x0026, Reset: 0x40, Name: PGA\_CONTROL\_3

This register controls the PGA connected to AIN3.

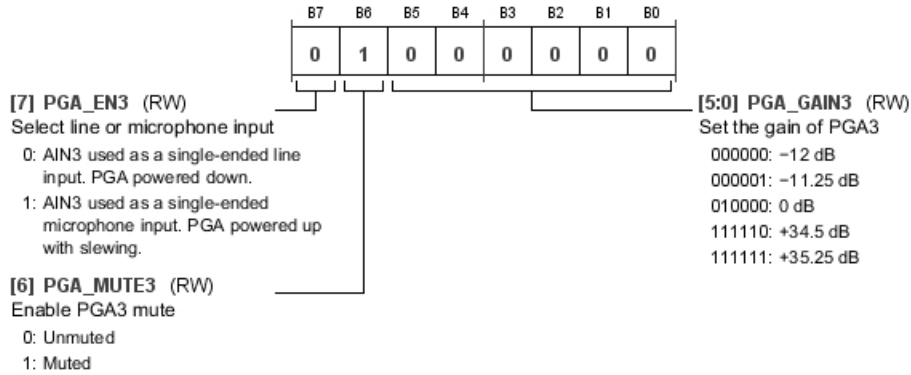

Table 67. Bit Descriptions for PGA\_CONTROL\_3

Bits	Bit Name	Settings	Description	Reset	Access
7	PGA_EN3	0 1	Select line or microphone input. Note that the PGA inverts the signal going through it. AIN3 used as a single-ended line input. PGA powered down. AIN3 used as a single-ended microphone input. PGA powered up with slewing.	0x0	RW
6	PGA_MUTE3	0 1	Enable PGA3 mute. When PGA is muted, PGA_GAIN3 is ignored. Unmuted Muted	0x1	RW
[5:0]	PGA_GAIN3	000000 000001 010000 111110 111111	Set the gain of PGA3. -12 dB -11.25 dB 0 dB +34.5 dB +35.25 dB	0x0	RW

**PGA SLEW CONTROL REGISTER**

Address: 0x0027, Reset: 0x00, Name: PGA\_STEP\_CONTROL

If PGA slew is disabled with the SLEW\_PDx controls, the SLEW\_RATE parameter is ignored for that PGA block.

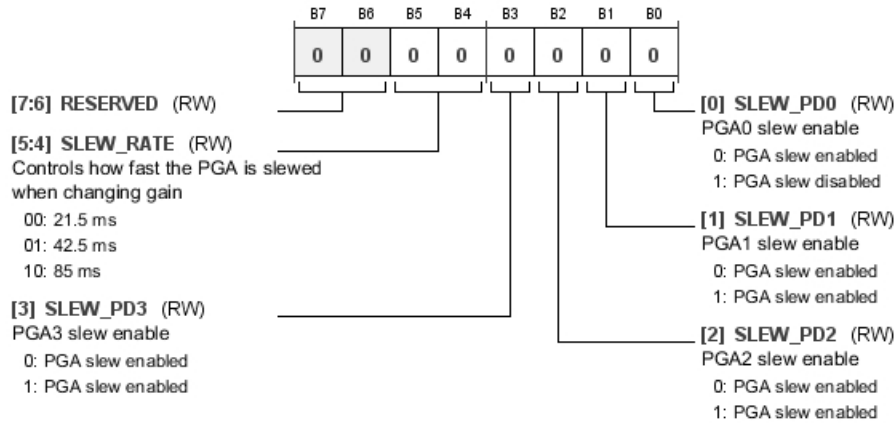

Table 68. Bit Descriptions for PGA\_STEP\_CONTROL

Bits	Bit Name	Settings	Description	Reset	Access
[5:4]	SLEW_RATE	00 01 10	Controls how fast the PGA is slewed when changing gain. 21.5 ms 42.5 ms 85 ms	0x0	RW
3	SLEW_PD3	0 1	PGA3 slew disable. 0 PGA slew enabled 1 PGA slew disabled	0x0	RW
2	SLEW_PD2	0 1	PGA2 slew disable. 0 PGA slew enabled 1 PGA slew disabled	0x0	RW
1	SLEW_PD1	0 1	PGA1 slew disable. 0 PGA slew enabled 1 PGA slew disabled	0x0	RW
0	SLEW_PD0	0 1	PGA0 slew disable. 0 PGA slew enabled 1 PGA slew disabled	0x0	RW

**PGA 10 dB GAIN BOOST REGISTER**

Address: 0x0028, Reset: 0x00, Name: PGA\_10DB\_BOOST

Each PGA can have an additional +10 dB gain added, making the PGA gain range -2 dB to +46 dB.

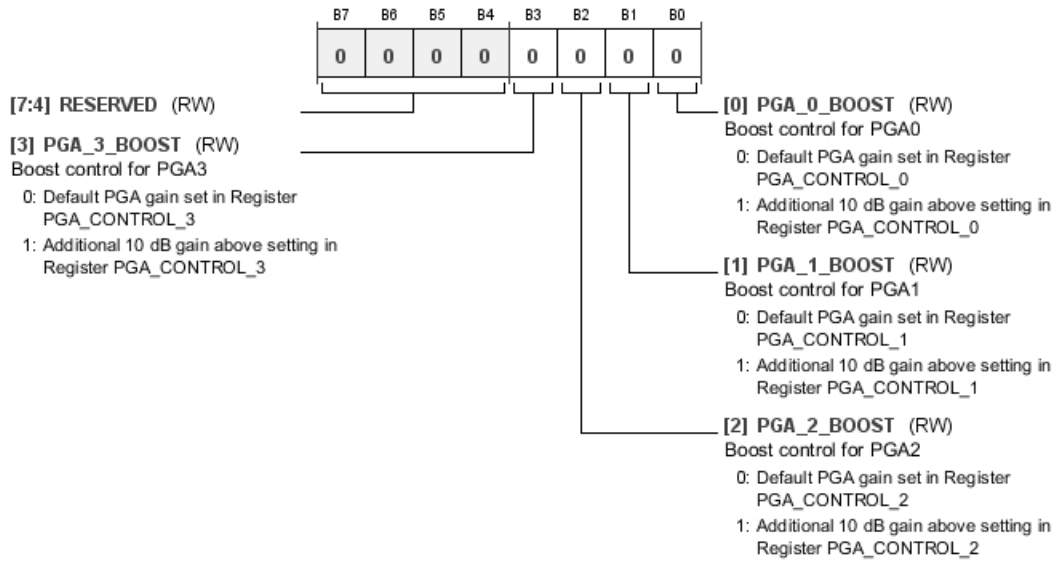

**Table 69. Bit Descriptions for PGA\_10DB\_BOOST**

Bits	Bit Name	Settings	Description	Reset	Access
3	PGA_3_BOOST	0 1	Boost control for PGA3. Default PGA gain set in Register PGA_CONTROL_3 Additional 10 dB gain above setting in Register PGA_CONTROL_3	0x0	RW
2	PGA_2_BOOST	0 1	Boost control for PGA2. Default PGA gain set in Register PGA_CONTROL_2 Additional 10 dB gain above setting in Register PGA_CONTROL_2	0x0	RW
1	PGA_1_BOOST	0 1	Boost control for PGA1. Default PGA gain set in Register PGA_CONTROL_1 Additional 10 dB gain above setting in Register PGA_CONTROL_1	0x0	RW
0	PGA_0_BOOST	0 1	Boost control for PGA0. Default PGA gain set in Register PGA_CONTROL_0 Additional 10 dB gain above setting in Register PGA_CONTROL_0	0x0	RW

**INPUT AND OUTPUT CAPACITOR CHARGING REGISTER**

Address: 0x0029, Reset: 0x3F, Name: POP\_SUPPRESS

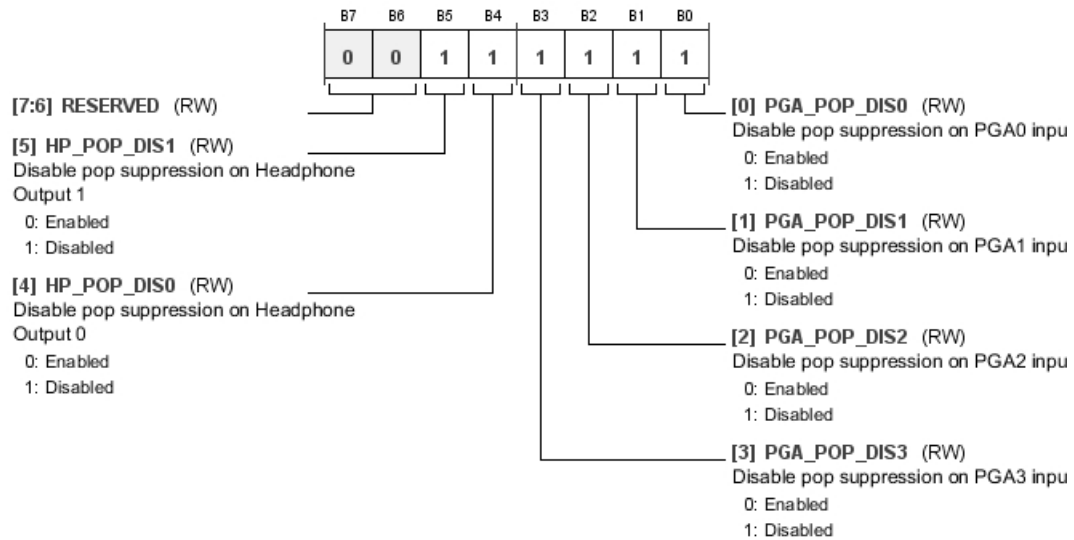

Table 70. Bit Descriptions for POP\_SUPPRESS

Bits	Bit Name	Settings	Description	Reset	Access
5	HP_POP_DIS1	0 1	Disable pop suppression on Headphone Output 1. Enabled Disabled	0x1	RW
4	HP_POP_DIS0	0 1	Disable pop suppression on Headphone Output 0. Enabled Disabled	0x1	RW
3	PGA_POP_DIS3	0 1	Disable pop suppression on PGA3 input. Enabled Disabled	0x1	RW
2	PGA_POP_DIS2	0 1	Disable pop suppression on PGA2 input. Enabled Disabled	0x1	RW
1	PGA_POP_DIS1	0 1	Disable pop suppression on PGA1 input. Enabled Disabled	0x1	RW
0	PGA_POP_DIS0	0 1	Disable pop suppression on PGA0 input. Enabled Disabled	0x1	RW

**DSP BYPASS PATH REGISTER**

Address: 0x002A, Reset: 0x00, Name: TALKTHRU

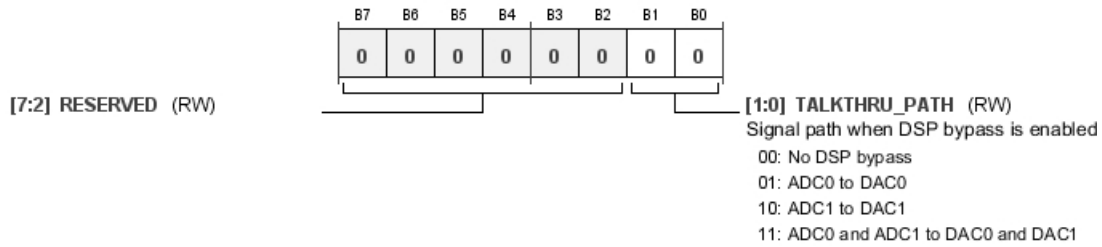

Table 71. Bit Descriptions for TALKTHRU

Bits	Bit Name	Settings	Description	Reset	Access
[1:0]	TALKTHRU_PATH	00 01 10 11	Signal path when DSP bypass is enabled. No DSP bypass ADC0 to DAC0 ADC1 to DAC1 ADC0 and ADC1 to DAC0 and DAC1	0x0	RW

**DSP BYPASS GAIN FOR PGA0 REGISTER**

Address: 0x002B, Reset: 0x00, Name: TALKTHRU\_GAIN0

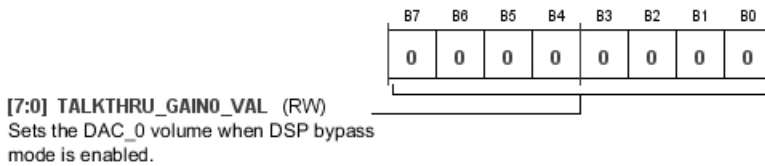

Table 72. Bit Descriptions for TALKTHRU\_GAIN0

Bits	Bit Name	Settings	Description	Reset	Access
[7:0]	TALKTHRU_GAIN0_VAL		Sets the DAC0 volume when DSP bypass mode is enabled.	0x00	RW

**DSP BYPASS GAIN FOR PGA1 REGISTER**

Address: 0x002C, Reset: 0x00, Name: TALKTHRU\_GAIN1

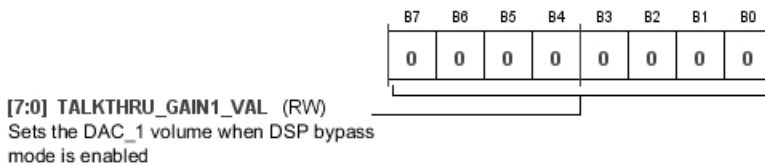

Table 73. Bit Descriptions for TALKTHRU\_GAIN1

Bits	Bit Name	Settings	Description	Reset	Access
[7:0]	TALKTHRU_GAIN1_VAL		Sets the DAC1 volume when DSP bypass mode is enabled.	0x00	RW

**MIC\_BIAS0\_1 CONTROL REGISTER**

Address: 0x002D, Reset: 0x00, Name: MIC\_BIAS

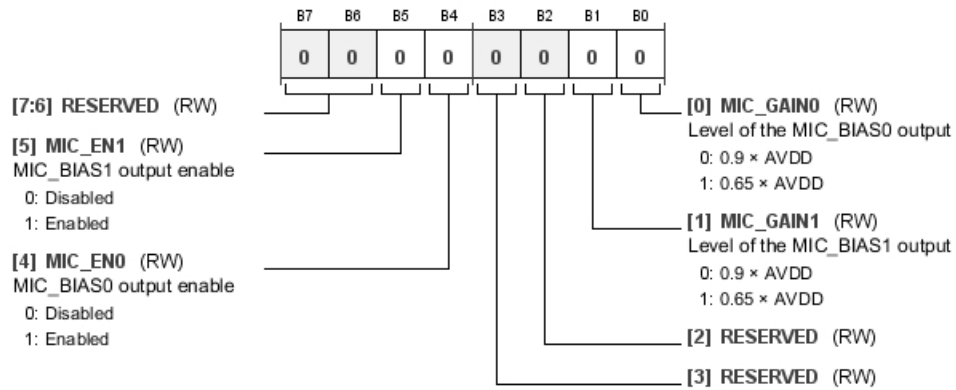

Table 74. Bit Descriptions for MIC\_BIAS

Bits	Bit Name	Settings	Description	Reset	Access
5	MIC_EN1	0 1	MICBIAS1 output enable. Disabled Enabled	0x0	RW
4	MIC_EN0	0 1	MICBIAS0 output enable. Disabled Enabled	0x0	RW
1	MIC_GAIN1	0 1	Level of the MICBIAS1 output. $0.9 \times AVDD$ $0.65 \times AVDD$	0x0	RW
0	MIC_GAIN0	0 1	Level of the MICBIAS0 output. $0.9 \times AVDD$ $0.65 \times AVDD$	0x0	RW

**DAC CONTROL REGISTER**

Address: 0x002E, Reset: 0x18, Name: DAC\_CONTROL1

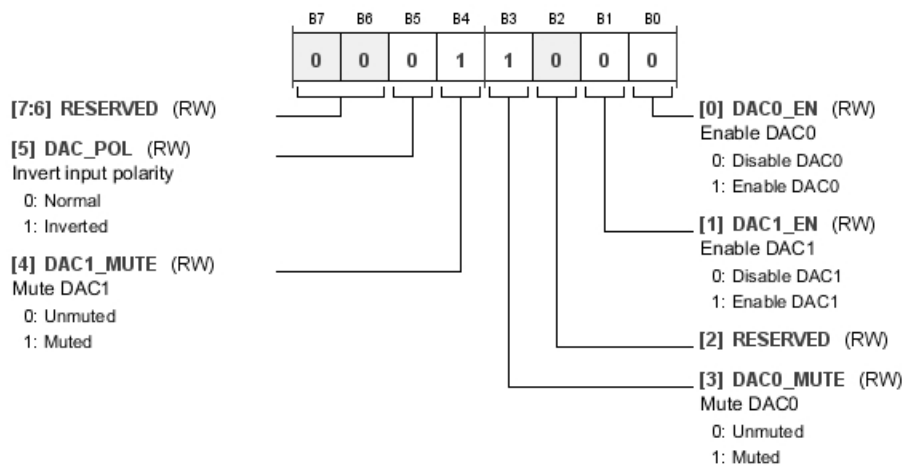
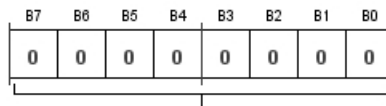

Table 75. Bit Descriptions for DAC\_CONTROL1

Bits	Bit Name	Settings	Description	Reset	Access
5	DAC_POL	0 1	Invert input polarity. Normal Inverted	0x0	RW
4	DAC1_MUTE	0 1	Mute DAC1. Unmuted Muted	0x1	RW
3	DAC0_MUTE	0 1	Mute DAC0. Unmuted Muted	0x1	RW
1	DAC1_EN	0 1	Enable DAC1. Disable DAC1 Enable DAC1	0x0	RW
0	DAC0_EN	0 1	Enable DAC0. Disable DAC0 Enable DAC0	0x0	RW

**DAC0 VOLUME CONTROL REGISTER**

Address: 0x002F, Reset: 0x00, Name: DAC0\_VOLUME



[7:0] DAC\_0\_VOL (RW)  
 DAC0 volume setting  
 00000000: 0 dB  
 00000001: -0.375 dB  
 11111111: -95.625 dB

Table 76. Bit Descriptions for DAC0\_VOLUME

Bits	Bit Name	Settings	Description	Reset	Access
[7:0]	DAC_0_VOL	00000000 00000001 11111111	DAC0 volume setting. 0 dB -0.375 dB -95.625 dB	0x00	RW

**DAC1 VOLUME CONTROL REGISTER**

Address: 0x0030, Reset: 0x00, Name: DAC1\_VOLUME

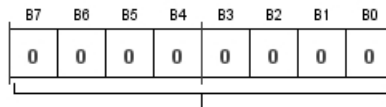

[7:0] DAC\_1\_VOL (RW)  
 DAC1 volume setting  
 00000000: 0 dB  
 00000001: -0.375 dB  
 11111111: -95.625 dB

Table 77. Bit Descriptions for DAC1\_VOLUME

Bits	Bit Name	Settings	Description	Reset	Access
[7:0]	DAC_1_VOL	00000000 00000001 11111111	DAC1 volume setting. 0 dB -0.375 dB -95.625 dB	0x00	RW

**HEADPHONE OUTPUT MUTES REGISTER**

Address: 0x0031, Reset: 0x0F, Name: OP\_STAGE\_MUTES

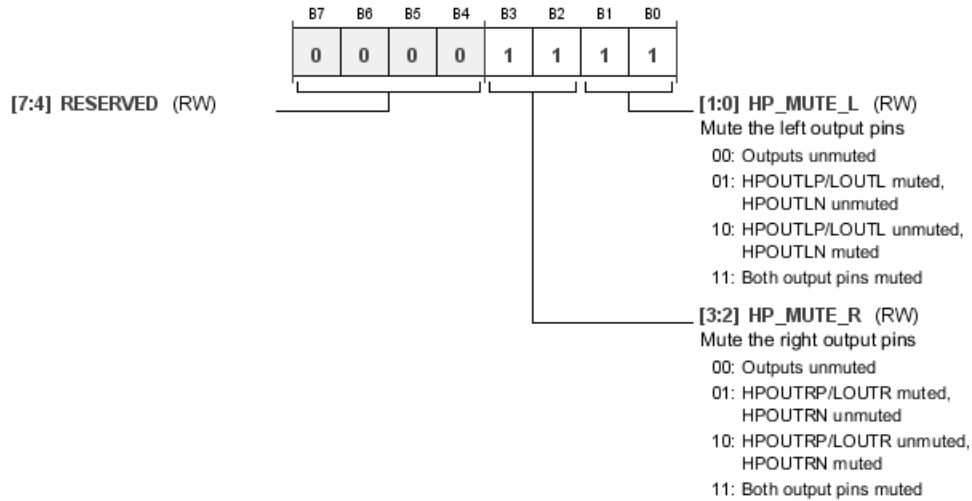

Table 78. Bit Descriptions for OP\_STAGE\_MUTES

Bits	Bit Name	Settings	Description	Reset	Access
[3:2]	HP_MUTE_R	00 01 10 11	Mute the right output pins. When a pin is muted, it can be used as a common-mode output. Outputs unmuted HPOUTRP/LOUTRP muted, HPOUTRN/LOUTRN unmuted HPOUTRP/LOUTRP unmuted, HPOUTRN/LOUTRN muted Both output pins muted	0x3	RW
[1:0]	HP_MUTE_L	00 01 10 11	Mute the left output pins. When a pin is muted, it can be used as a common-mode output. Outputs unmuted HPOUTLP/LOUTLP muted, HPOUTLN/LOUTLN unmuted HPOUTLP/LOUTLP unmuted, HPOUTLN/LOUTLN muted Both output pins muted	0x3	RW

**SERIAL PORT CONTROL 0 REGISTER**

Address: 0x0032, Reset: 0x00, Name: SAI\_0

Using 16-bit serial I/O limits device performance.

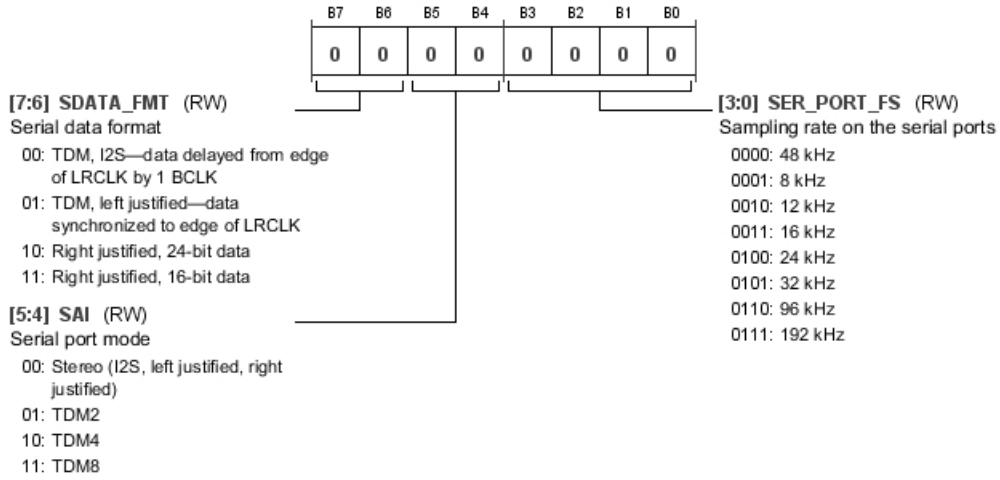

**Table 79. Bit Descriptions for SAI\_0**

Bits	Bit Name	Settings	Description	Reset	Access
[7:6]	SDATA_FMT	00 01 10 11	Serial data format. TDM, I <sup>2</sup> S—data delayed from edge of LRCLK by 1 BCLK cycle TDM, left justified—data synchronized to edge of LRCLK Right justified, 24-bit data Right justified, 16-bit data	0x0	RW
[5:4]	SAI	00 01 10 11	Serial port mode. Stereo (I <sup>2</sup> S, left justified, right justified) TDM2 TDM4 TDM8	0x0	RW
[3:0]	SER_PORT_FS	0000 0001 0010 0011 0100 0101 0110 0111	Sampling rate on the serial ports. 48 kHz 8 kHz 12 kHz 16 kHz 24 kHz 32 kHz 96 kHz 192 kHz	0x0	RW

**SERIAL PORT CONTROL 1 REGISTER**

Address: 0x0033, Reset: 0x00, Name: SAI\_1

Using 16-bit serial I/O limits device performance.

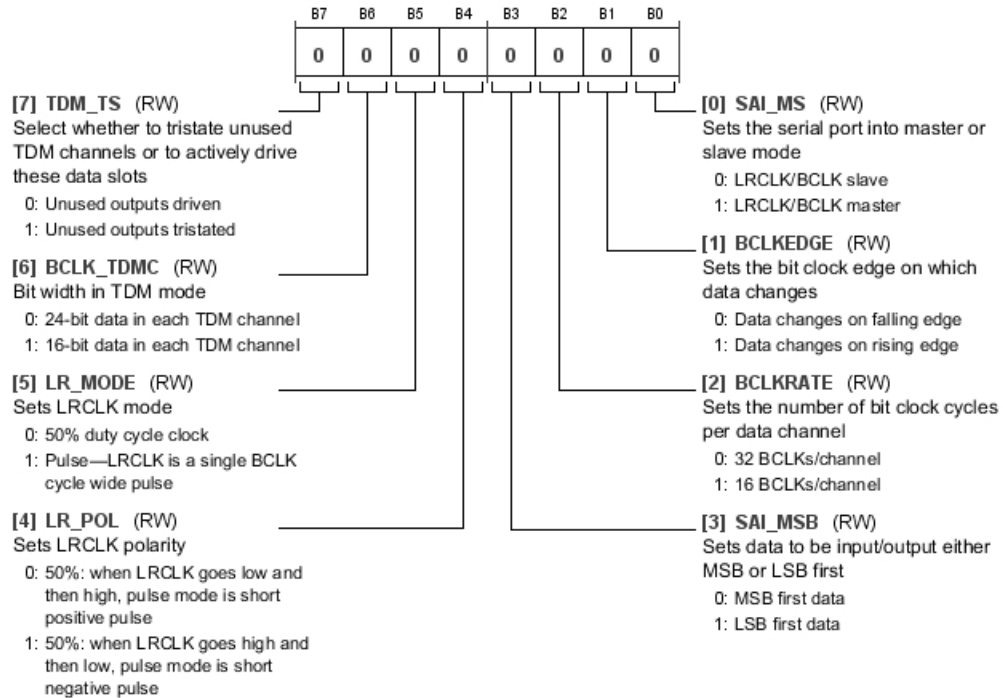
**Table 80. Bit Descriptions for SAI\_1**

Bits	Bit Name	Settings	Description	Reset	Access
7	TDM_TS	0 1	Select whether to tristate unused TDM channels or to actively drive these data slots. Unused outputs driven Unused outputs tristated	0x0	RW
6	BCLK_TDMC	0 1	Bit width in TDM mode. 24-bit data in each TDM channel 16-bit data in each TDM channel	0x0	RW
5	LR_MODE	0 1	Sets LRCLK mode. 50% duty cycle clock Pulse—LRCLK is a single BCLK cycle wide pulse	0x0	RW
4	LR_POL	0 1	Sets LRCLK polarity. 50%: when LRCLK goes low and then high, pulse mode is short positive pulse 50%: when LRCLK goes high and then low, pulse mode is short negative pulse	0x0	RW
3	SAI_MSB	0 1	Sets data to be input/output either MSB or LSB first. MSB first data LSB first data	0x0	RW
2	BCLKRATE	0 1	Sets the number of bit clock cycles per data channel. 32 BCLK cycles/channel 16 BCLK cycles/channel	0x0	RW
1	BCLKEDGE	0 1	Sets the bit clock edge on which data changes. Data changes on falling edge Data changes on rising edge	0x0	RW
0	SAI_MS	0 1	Sets the serial port into master or slave mode. LRCLK/BCLK slave LRCLK/BCLK master	0x0	RW

**TDM OUTPUT CHANNEL DISABLE REGISTER**

Address: 0x0034, Reset: 0x00, Name: SOUT\_CONTROL0

This register is for use only in TDM mode.

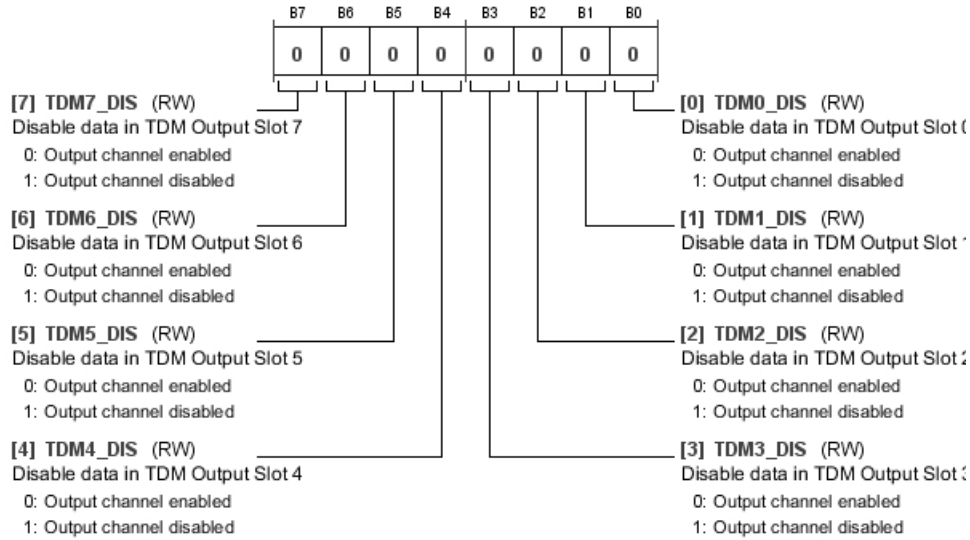

Table 81. Bit Descriptions for SOUT\_CONTROL0

Bits	Bit Name	Settings	Description	Reset	Access
7	TDM7_DIS	0 1	Disable data in TDM Output Slot 7. Output channel enabled Output channel disabled	0x0	RW
6	TDM6_DIS	0 1	Disable data in TDM Output Slot 6. Output channel enabled Output channel disabled	0x0	RW
5	TDM5_DIS	0 1	Disable data in TDM Output Slot 5. Output channel enabled Output channel disabled	0x0	RW
4	TDM4_DIS	0 1	Disable data in TDM Output Slot 4. Output channel enabled Output channel disabled	0x0	RW
3	TDM3_DIS	0 1	Disable data in TDM Output Slot 3. Output channel enabled Output channel disabled	0x0	RW
2	TDM2_DIS	0 1	Disable data in TDM Output Slot 2. Output channel enabled Output channel disabled	0x0	RW
1	TDM1_DIS	0 1	Disable data in TDM Output Slot 1. Output channel enabled Output channel disabled	0x0	RW
0	TDM0_DIS	0 1	Disable data in TDM Output Slot 0. Output channel enabled Output channel disabled	0x0	RW

**PDM ENABLE REGISTER**

Address: 0x0036, Reset: 0x00, Name: PDM\_OUT

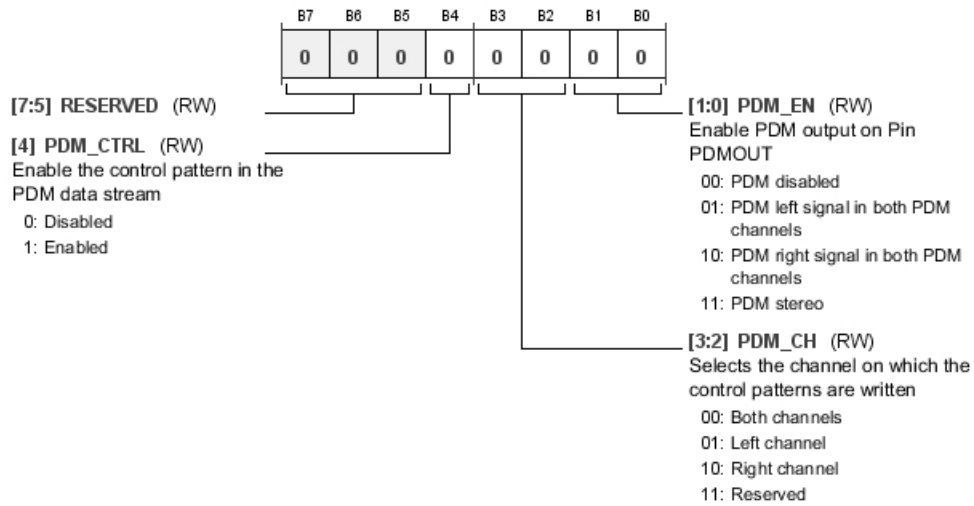

Table 82. Bit Descriptions for PDM\_OUT

Bits	Bit Name	Settings	Description	Reset	Access
4	PDM_CTRL	0 1	Enable the control pattern in the PDM data stream. Disabled Enabled	0x0	RW
[3:2]	PDM_CH	00 01 10 11	Selects the channel on which the control patterns are written. These control bits should not be changed while the PDM channel is operating and transmitting audio. Both channels Left channel Right channel Reserved	0x0	RW
[1:0]	PDM_EN	00 01 10 11	Enable PDM output on Pin PDMOUT. PDM disabled PDM left signal in both PDM channels PDM right signal in both PDM channels PDM stereo	0x0	RW

**PDM PATTERN SETTING REGISTER**

Address: 0x0037, Reset: 0x00, Name: PDM\_PATTERN

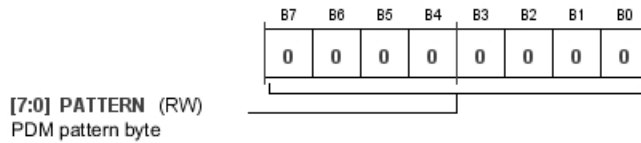

Table 83. Bit Descriptions for PDM\_PATTERN

Bits	Bit Name	Settings	Description	Reset	Access
[7:0]	PATTERN		PDM pattern byte. The PDM pattern byte should not be changed while the PDM channel is operating and transmitting the pattern.	0x00	RW

**MP0 FUNCTION SETTING REGISTER**

Address: 0x0038, Reset: 0x00, Name: MODE\_MP0

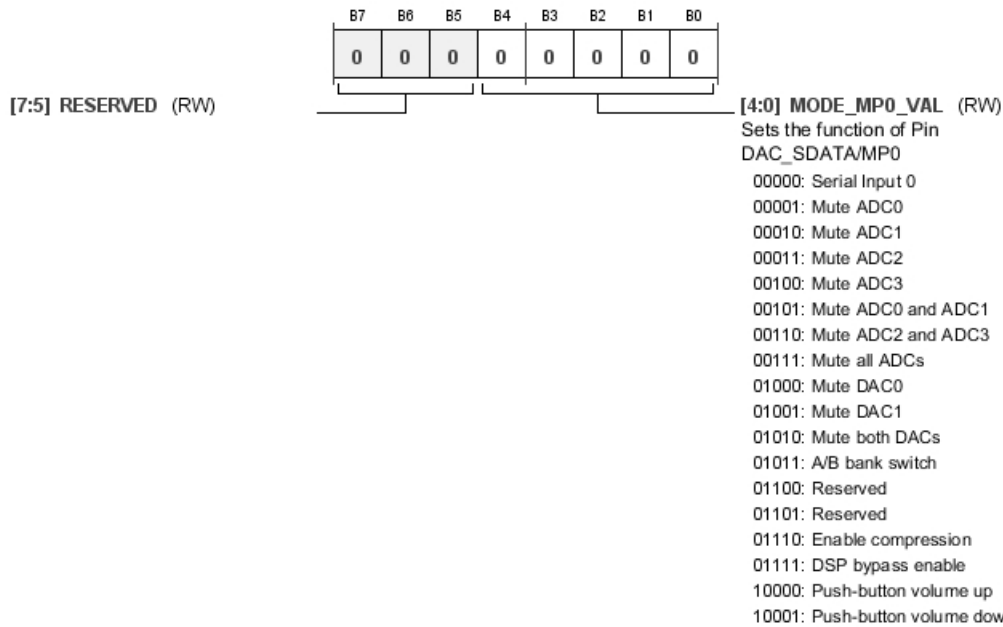

Table 84. Bit Descriptions for MODE\_MP0

Bits	Bit Name	Settings	Description	Reset	Access
[4:0]	MODE_MP0_VAL		Sets the function of Pin DAC_SDATA/MP0.	0x00	RW
		00000	Serial Input 0		
		00001	Mute ADC0		
		00010	Mute ADC1		
		00011	Mute ADC2		
		00100	Mute ADC3		
		00101	Mute ADC0 and ADC1		
		00110	Mute ADC2 and ADC3		
		00111	Mute all ADCs		
		01000	Mute DAC0		
		01001	Mute DAC1		
		01010	Mute both DACs		

Bits	Bit Name	Settings	Description	Reset	Access
		01011	A/B bank switch		
		01100	Reserved		
		01101	Reserved		
		01110	Enable compression		
		01111	DSP bypass enable		
		10000	Push-button volume up		
		10001	Push-button volume down		

**MP1 FUNCTION SETTING REGISTER**

Address: 0x0039, Reset: 0x10, Name: MODE\_MP1

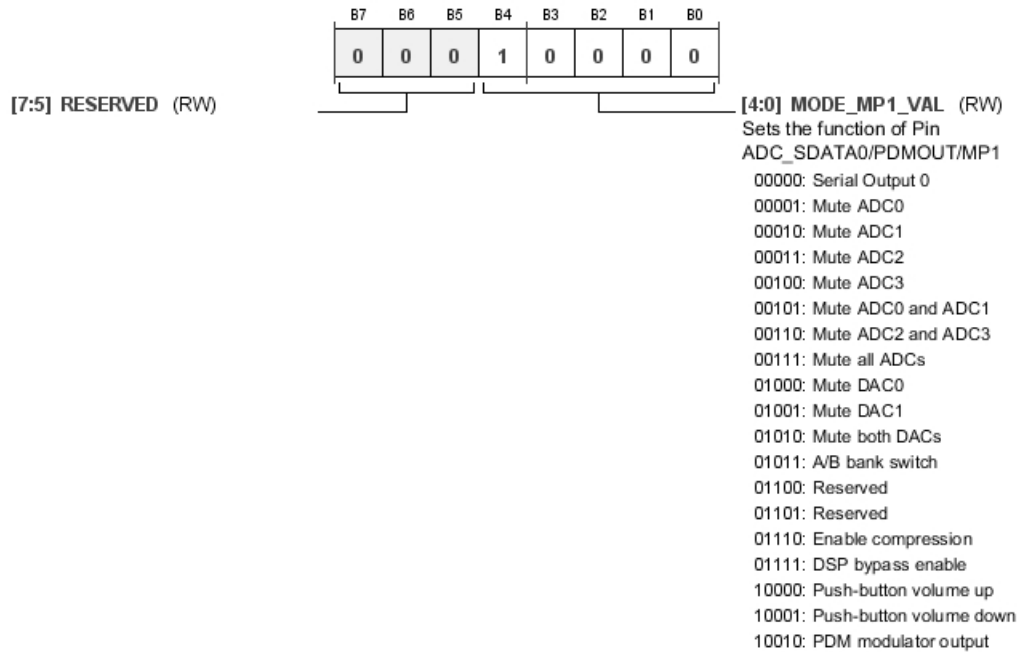

Table 85. Bit Descriptions for MODE\_MP1

Bits	Bit Name	Settings	Description	Reset	Access
[4:0]	MODE_MP1_VAL		Sets the function of Pin ADC_SDATA0/PDMOUT/MP1.	0x10	RW
		00000	Serial Output 0		
		00001	Mute ADC0		
		00010	Mute ADC1		
		00011	Mute ADC2		
		00100	Mute ADC3		
		00101	Mute ADC0 and ADC1		
		00110	Mute ADC2 and ADC3		
		00111	Mute all ADCs		
		01000	Mute DAC0		
		01001	Mute DAC1		
		01010	Mute both DACs		
		01011	A/B bank switch		
		01100	Reserved		
		01101	Reserved		
		01110	Enable compression		
		01111	DSP bypass enable		

Bits	Bit Name	Settings	Description	Reset	Access
		10000	Push-button volume up		
		10001	Push-button volume down		
		10010	PDM modulator output		

**MP2 FUNCTION SETTING REGISTER**

Address: 0x003A, Reset: 0x00, Name: MODE\_MP2

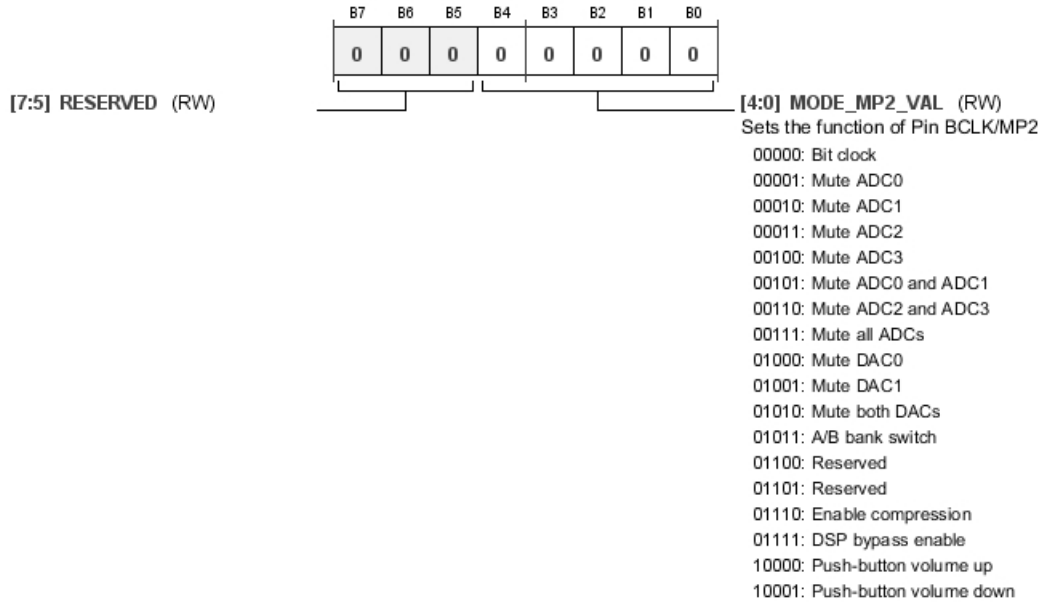

Table 86. Bit Descriptions for MODE\_MP2

Bits	Bit Name	Settings	Description	Reset	Access
[4:0]	MODE_MP2_VAL		Sets the function of Pin BCLK/MP2.	0x00	RW
		00000	Bit clock		
		00001	Mute ADC0		
		00010	Mute ADC1		
		00011	Mute ADC2		
		00100	Mute ADC3		
		00101	Mute ADC0 and ADC1		
		00110	Mute ADC2 and ADC3		
		00111	Mute all ADCs		
		01000	Mute DAC0		
		01001	Mute DAC1		
		01010	Mute both DACs		
		01011	A/B bank switch		
		01100	Reserved		
		01101	Reserved		
		01110	Enable compression		
		01111	DSP bypass enable		
		10000	Push-button volume up		
		10001	Push-button volume down		

**MP3 FUNCTION SETTING REGISTER**

Address: 0x003B, Reset: 0x00, Name: MODE\_MP3

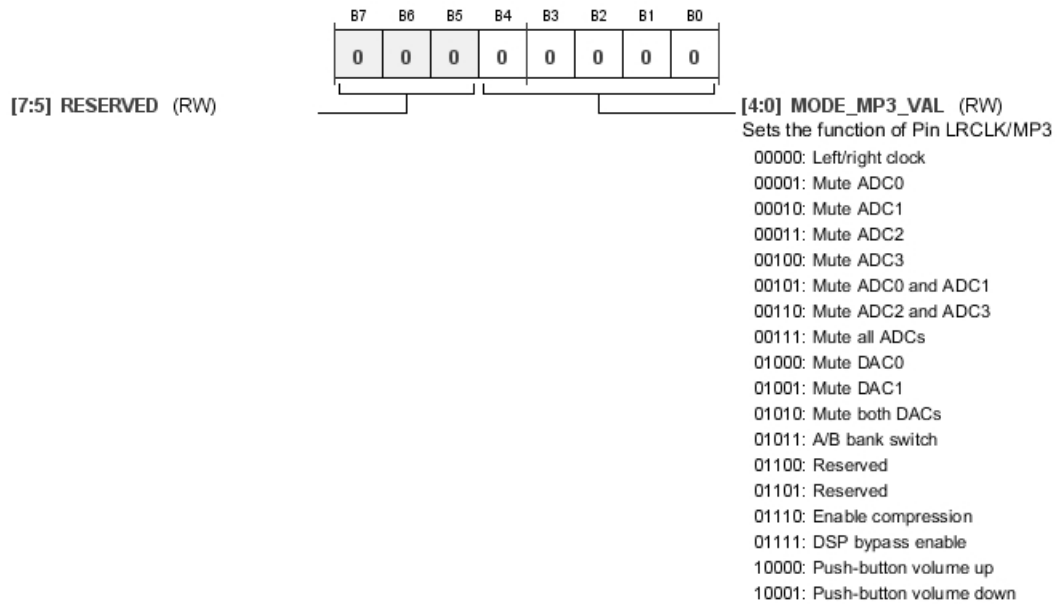

Table 87. Bit Descriptions for MODE\_MP3

Bits	Bit Name	Settings	Description	Reset	Access
[4:0]	MODE_MP3_VAL		Sets the function of Pin LRCLK/MP3.	0x00	RW
		00000	Left/right clock		
		00001	Mute ADC0		
		00010	Mute ADC1		
		00011	Mute ADC2		
		00100	Mute ADC3		
		00101	Mute ADC0 and ADC1		
		00110	Mute ADC2 and ADC3		
		00111	Mute all ADCs		
		01000	Mute DAC0		
		01001	Mute DAC1		
		01010	Mute both DACs		
		01011	A/B bank switch		
		01100	Reserved		
		01101	Reserved		
		01110	Enable compression		
		01111	DSP bypass enable		
		10000	Push-button volume up		
		10001	Push-button volume down		

**MP4 FUNCTION SETTING REGISTER**

Address: 0x003C, Reset: 0x00, Name: MODE\_MP4

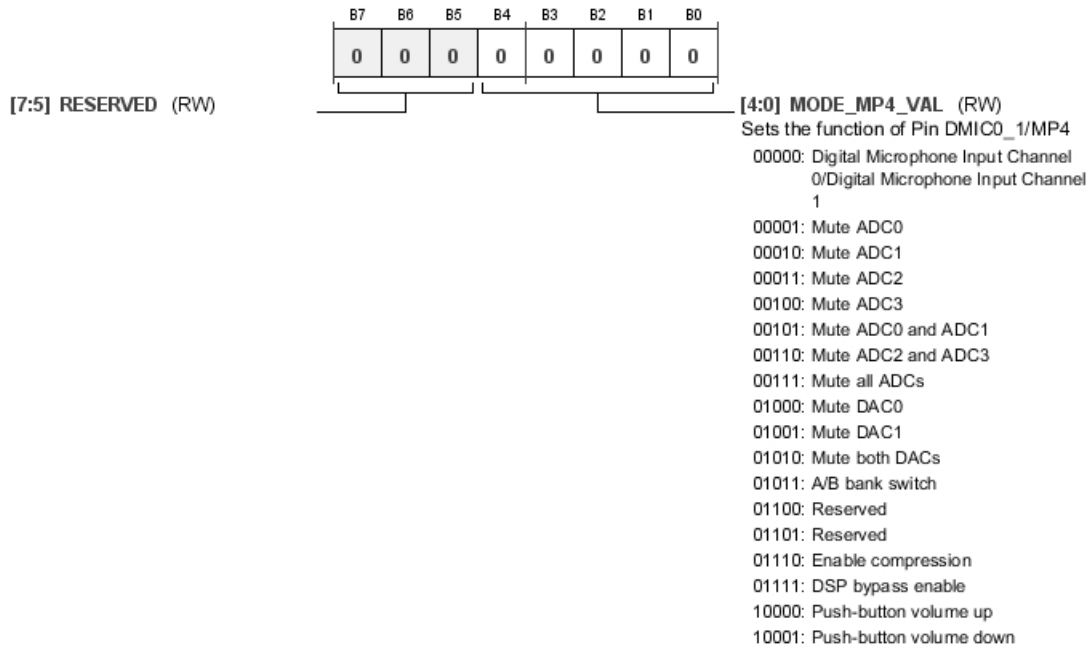

Table 88. Bit Descriptions for MODE\_MP4

Bits	Bit Name	Settings	Description	Reset	Access
[4:0]	MODE_MP4_VAL		Sets the function of Pin DMIC0_1/MP4.	0x00	RW
		00000	Digital Microphone Input Channel 0/Digital Microphone Input Channel 1		
		00001	Mute ADC0		
		00010	Mute ADC1		
		00011	Mute ADC2		
		00100	Mute ADC3		
		00101	Mute ADC0 and ADC1		
		00110	Mute ADC2 and ADC3		
		00111	Mute all ADCs		
		01000	Mute DAC0		
		01001	Mute DAC1		
		01010	Mute both DACs		
		01011	A/B bank switch		
		01100	Reserved		
		01101	Reserved		
		01110	Enable compression		
		01111	DSP bypass enable		
		10000	Push-button volume up		
		10001	Push-button volume down		

**MP5 FUNCTION SETTING REGISTER**

Address: 0x003D, Reset: 0x00, Name: MODE\_MP5

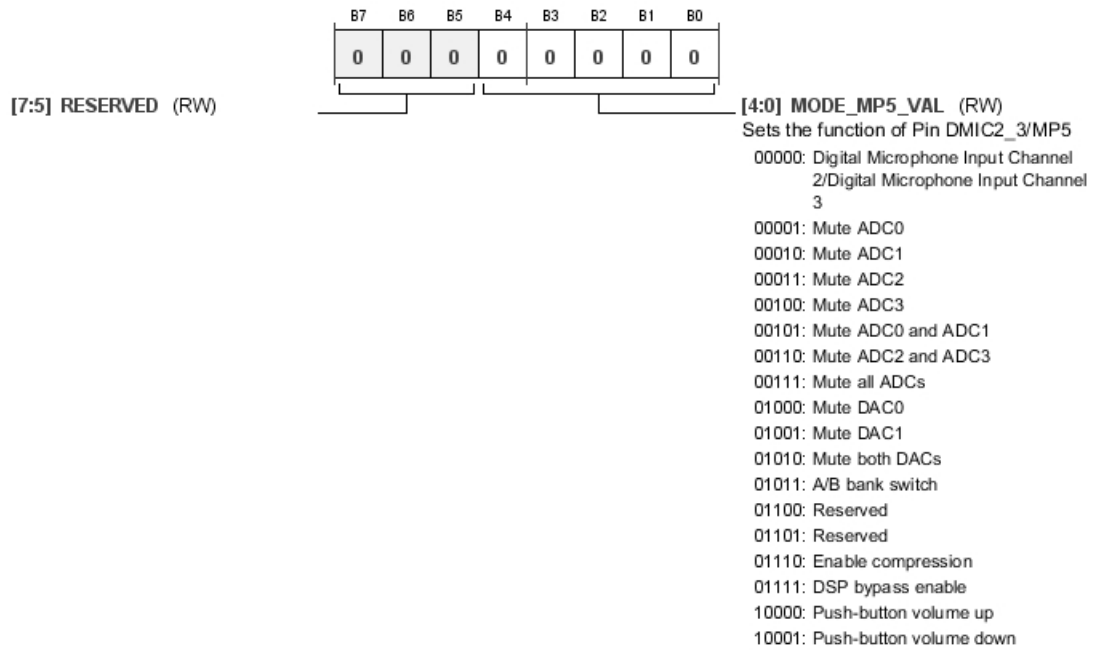

Table 89. Bit Descriptions for MODE\_MP5

Bits	Bit Name	Settings	Description	Reset	Access
[4:0]	MODE_MP5_VAL	00000 00001 00010 00011 00100 00101 00110 00111 01000 01001 01010 01011 01100 01101 01110 01111 10000 10001	Sets the function of Pin DMIC2_3/MP5. Digital Microphone Input Channel 2/Digital Microphone Input Channel 3 Mute ADC0 Mute ADC1 Mute ADC2 Mute ADC3 Mute ADC0 and ADC1 Mute ADC2 and ADC3 Mute all ADCs Mute DAC0 Mute DAC1 Mute both DACs A/B bank switch Reserved Reserved Enable compression DSP bypass enable Push-button volume up Push-button volume down	0x00	RW

**MP6 FUNCTION SETTING REGISTER**

Address: 0x003E, Reset: 0x11, Name: MODE\_MP6

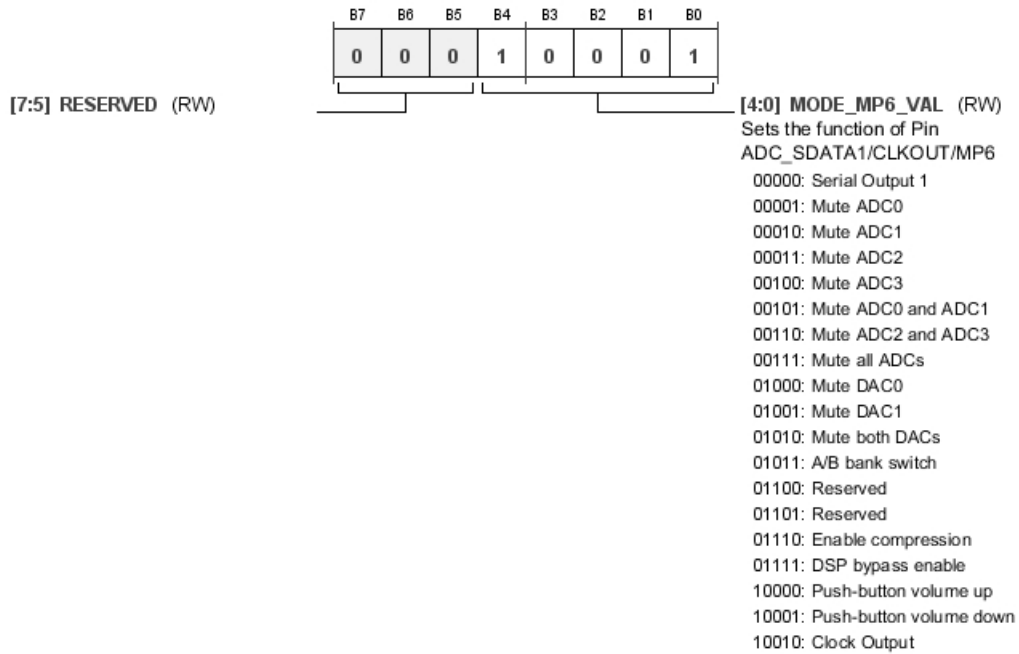

Table 90. Bit Descriptions for MODE\_MP6

Bits	Bit Name	Settings	Description	Reset	Access
[4:0]	MODE_MP6_VAL		Sets the function of Pin ADC_SDATA1/CLKOUT/MP6.	0x11	RW
		00000	Serial Output 1		
		00001	Mute ADC0		
		00010	Mute ADC1		
		00011	Mute ADC2		
		00100	Mute ADC3		
		00101	Mute ADC0 and ADC1		
		00110	Mute ADC2 and ADC3		
		00111	Mute all ADCs		
		01000	Mute DAC0		
		01001	Mute DAC1		
		01010	Mute both DACs		
		01011	A/B bank switch		
		01100	Reserved		
		01101	Reserved		
		01110	Enable compression		
		01111	DSP bypass enable		
		10000	Push-button volume up		
		10001	Push-button volume down		
		10010	Clock output		

**PUSH-BUTTON VOLUME SETTINGS REGISTER**

Address: 0x003F, Reset: 0x00, Name: PB\_VOL\_SET

This register must be written before Bits PB\_VOL\_CONV\_VAL are set to something other than the default value. Otherwise, the push-button volume control is initialized to -96 dB.

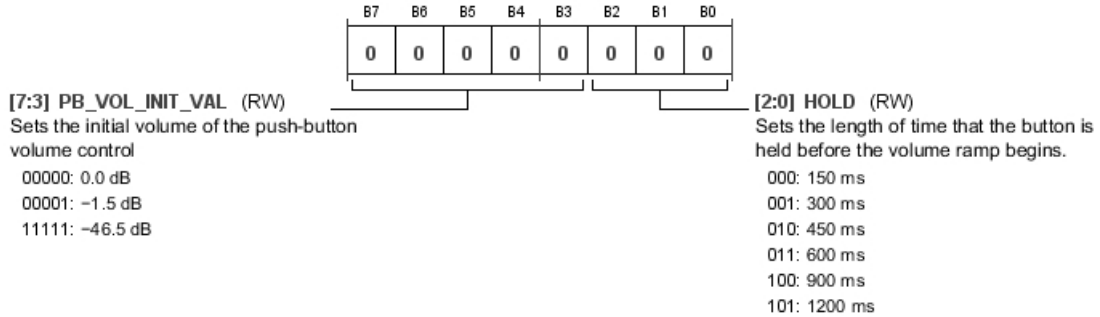

**Table 91. Bit Descriptions for PB\_VOL\_SET**

Bits	Bit Name	Settings	Description	Reset	Access
[7:3]	PB_VOL_INIT_VAL	00000 00001 11111	Sets the initial volume of the push-button volume control. Each increment of this register attenuates the level by 1.5 dB, from 0 dB to -46.5 dB. 0.0 dB -1.5 dB -46.5 dB	0x00	RW
[2:0]	HOLD	000 001 010 011 100 101	Sets the length of time that the button is held before the volume ramp begins. 150 ms 300 ms 450 ms 600 ms 900 ms 1200 ms	0x0	RW

**PUSH-BUTTON VOLUME CONTROL ASSIGNMENT REGISTER**

Address: 0x0040, Reset: 0x87, Name: PB\_VOL\_CONV

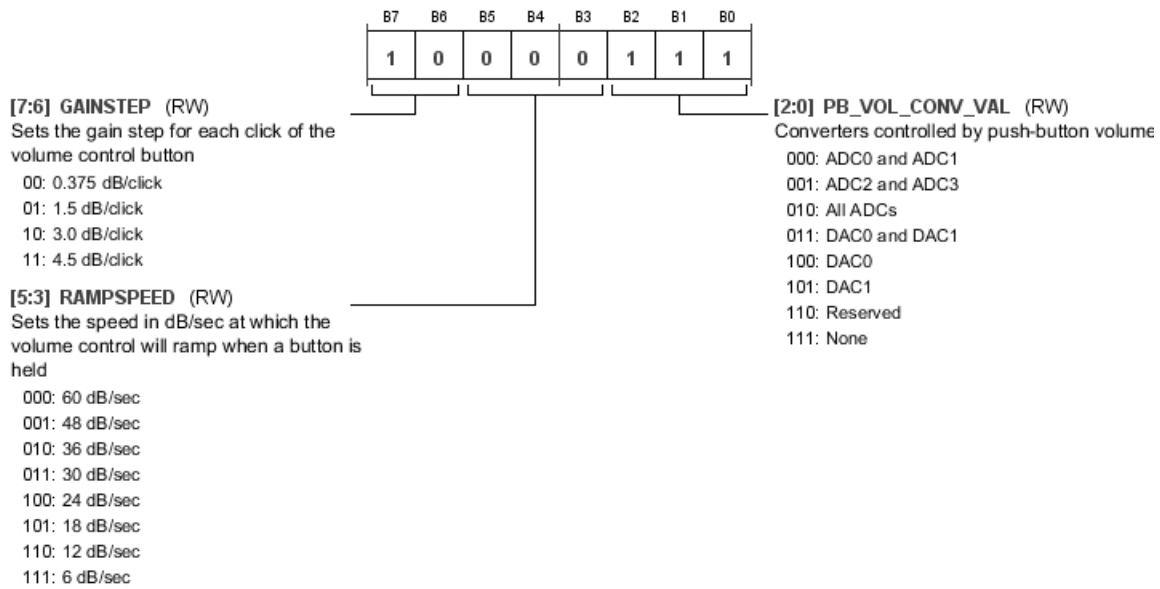

Table 92. Bit Descriptions for PB\_VOL\_CONV

Bits	Bit Name	Settings	Description	Reset	Access
[7:6]	GAINSTEP	00 01 10 11	Sets the gain step for each press of the volume control button. 0.375 dB/press 1.5 dB/press 3.0 dB/press 4.5 dB/press	0x2	RW
[5:3]	RAMPSPEED	000 001 010 011 100 101 110 111	Sets the speed in dB/sec at which the volume control ramps when a button is pressed. 60 dB/sec 48 dB/sec 36 dB/sec 30 dB/sec 24 dB/sec 18 dB/sec 12 dB/sec 6 dB/sec	0x0	RW
[2:0]	PB_VOL_CONV_VAL	000 001 010 011 100 101 110 111	Converters controlled by push-button volume. The push-button volume control is enabled when these bits are set to something other than the default setting (111). When set to 111, the push-button volume is disabled and the converter volumes are set by the ADCx_VOLUME and DACx_VOLUME registers. ADC0 and ADC1 ADC2 and ADC3 All ADCs DAC0 and DAC1 DAC0 DAC1 Reserved None (default)	0x7	RW

**DEBOUNCE MODES REGISTER**

Address: 0x0041, Reset: 0x05, Name: DEBOUNCE\_MODE

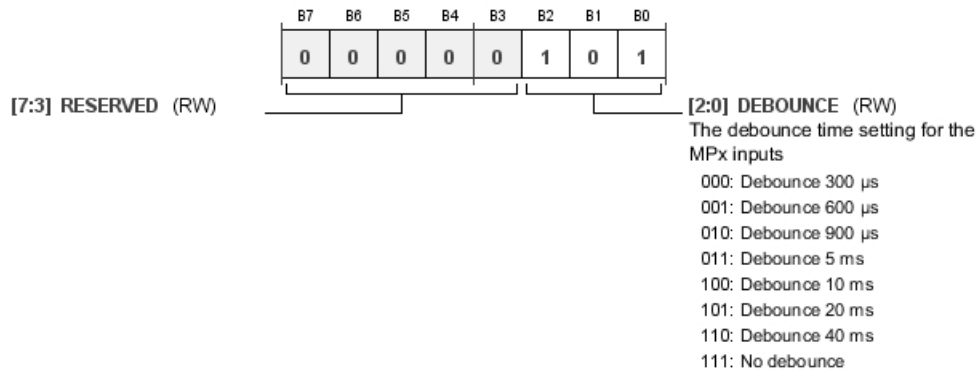

Table 93. Bit Descriptions for DEBOUNCE\_MODE

Bits	Bit Name	Settings	Description	Reset	Access
[2:0]	DEBOUNCE	000 001 010 011 100 101 110 111	The debounce time setting for the MPx inputs. Debounce 300 $\mu$ s Debounce 600 $\mu$ s Debounce 900 $\mu$ s Debounce 5 ms Debounce 10 ms Debounce 20 ms Debounce 40 ms No debounce	0x5	RW

**HEADPHONE LINE OUTPUT SELECT REGISTER**

Address: 0x0043, Reset: 0x0F, Name: OP\_STAGE\_CTRL

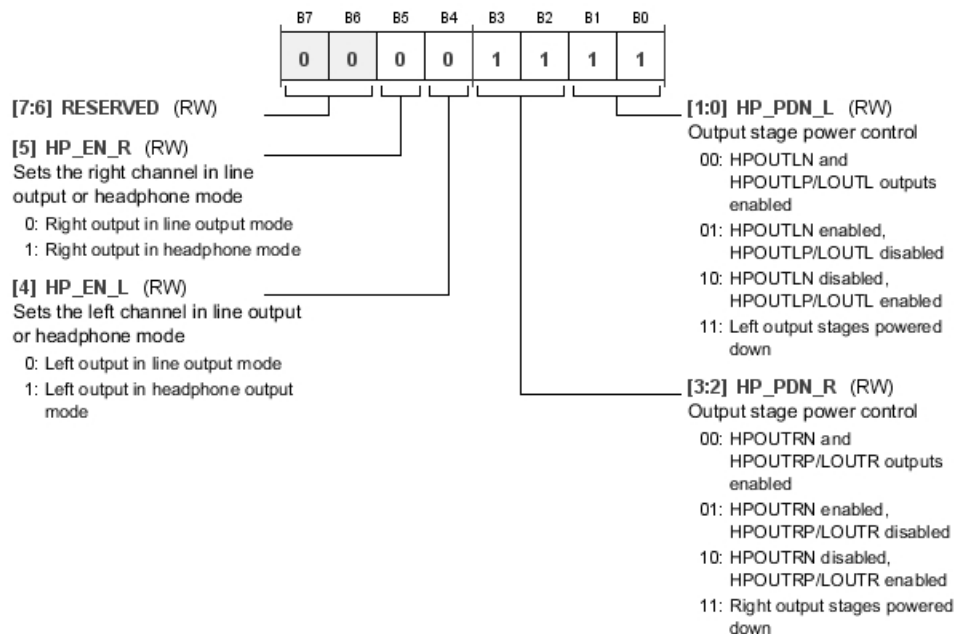

Table 94. Bit Descriptions for OP\_STAGE\_CTRL

Bits	Bit Name	Settings	Description	Reset	Access
5	HP_EN_R	0 1	Sets the right channel in line output or headphone mode. Right output in line output mode Right output in headphone mode	0x0	RW
4	HP_EN_L	0 1	Sets the left channel in line output or headphone mode. Left output in line output mode Left output in headphone output mode	0x0	RW
[3:2]	HP_PDN_R	00 01 10 11	Output stage power control. Powers down the right output stage, regardless of whether the device is in line output or headphone mode. After enabling the headphone output, wait at least 6 ms before unmuting the headphone output by setting HP_MUTE_R in the OP_STAGE_MUTES register to 00. HPOUTRN/LOUTRN and HPOUTRP/LOUTRP outputs enabled HPOUTRN/LOUTRN enabled, HPOUTRP/LOUTRP disabled HPOUTRN/LOUTRN disabled, HPOUTRP/LOUTRP enabled Right output stages powered down	0x3	RW
[1:0]	HP_PDN_L	00 01 10 11	Output stage power control. Powers down the left output stage, regardless of whether the device is in line output or headphone mode. After enabling the headphone output, wait at least 6 ms before unmuting the headphone output by setting HP_MUTE_L in the OP_STAGE_MUTES register to 00. HPOUTLN/LOUTLN and HPOUTLP/LOUTLP outputs enabled HPOUTLN/LOUTLN enabled, HPOUTLP/LOUTLP disabled HPOUTLN/LOUTLN disabled, HPOUTLP/LOUTLP enabled Left output stages powered down	0x3	RW

**DECIMATOR POWER CONTROL REGISTER**

Address: 0x0044, Reset: 0x00, Name: DECIM\_PWR\_MODES

These bits enable clocks to the digital filters and ASRC decimator filters of the ADCs. These bits must be enabled for all channels that will be used in the design. To use the ADCs, these SINC\_x\_EN bits must be enabled along with the appropriate ADC\_x\_EN bits in the ADC\_CONTROL2 and ADC\_CONTROL3 registers. If the digital microphone inputs are used, the SINC\_x\_EN bits can be set without setting ADC\_x\_EN.

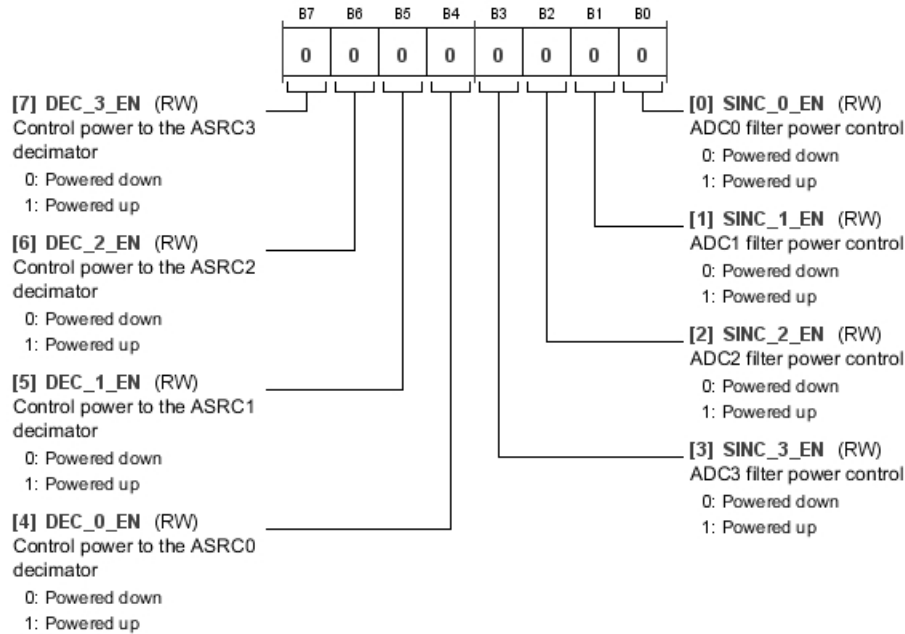

Table 95. Bit Descriptions for DECIM\_PWR\_MODES

Bits	Bit Name	Settings	Description	Reset	Access
7	DEC_3_EN	0 1	Control power to the ASRC3 decimator. Powered down Powered up	0x0	RW
6	DEC_2_EN	0 1	Control power to the ASRC2 decimator. Powered down Powered up	0x0	RW
5	DEC_1_EN	0 1	Control power to the ASRC1 decimator. Powered down Powered up	0x0	RW
4	DEC_0_EN	0 1	Control power to the ASRC0 decimator. Powered down Powered up	0x0	RW
3	SINC_3_EN	0 1	ADC3 filter power control. Powered down Powered up	0x0	RW
2	SINC_2_EN	0 1	ADC2 filter power control. Powered down Powered up	0x0	RW
1	SINC_1_EN	0 1	ADC1 filter power control. Powered down Powered up	0x0	RW
0	SINC_0_EN	0 1	ADC0 filter power control. Powered down Powered up	0x0	RW

**ASRC INTERPOLATOR AND DAC MODULATOR POWER CONTROL REGISTER**

Address: 0x0045, Reset: 0x00, Name: INTERP\_PWR\_MODES

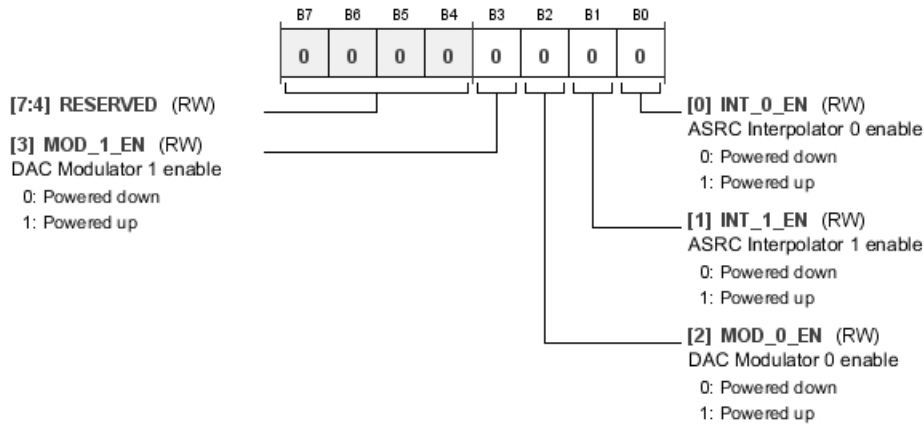

Table 96. Bit Descriptions for INTERP\_PWR\_MODES

Bits	Bit Name	Settings	Description	Reset	Access
3	MOD_1_EN	0 1	DAC Modulator 1 enable. 0: Powered down 1: Powered up	0x0	RW
2	MOD_0_EN	0 1	DAC Modulator 0 enable. 0: Powered down 1: Powered up	0x0	RW
1	INT_1_EN	0 1	ASRC Interpolator 1 enable. 0: Powered down 1: Powered up	0x0	RW
0	INT_0_EN	0 1	ASRC Interpolator 0 enable. 0: Powered down 1: Powered up	0x0	RW

**ANALOG BIAS CONTROL 0 REGISTER**

Address: 0x0046, Reset: 0x00, Name: BIAS\_CONTROL0

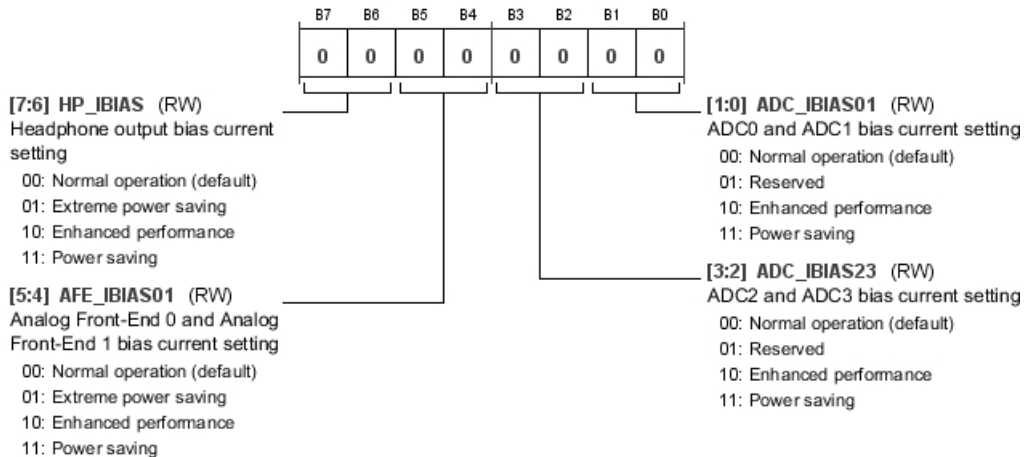

Table 97. Bit Descriptions for BIAS\_CONTROL0

Bits	Bit Name	Settings	Description	Reset	Access
[7:6]	HP_IBIAS	00 01 10 11	Headphone output bias current setting. Higher bias currents result in higher performance. Normal operation (default) Extreme power saving Enhanced performance Power saving	0x0	RW
[5:4]	AFE_IBIAS01	00 01 10 11	Analog Front-End 0 and Analog Front-End 1 bias current setting. Higher bias currents result in higher performance. Normal operation (default) Extreme power saving Enhanced performance Power saving	0x0	RW
[3:2]	ADC_IBIAS23	00 01 10 11	ADC2 and ADC3 bias current setting. Higher bias currents result in higher performance. Normal operation (default) Reserved Enhanced performance Power saving	0x0	RW
[1:0]	ADC_IBIAS01	00 01 10 11	ADC0 and ADC1 bias current setting. Higher bias currents result in higher performance. Normal operation (default) Reserved Enhanced performance Power saving	0x0	RW

**ANALOG BIAS CONTROL 1 REGISTER**

Address: 0x0047, Reset: 0x00, Name: BIAS\_CONTROL1

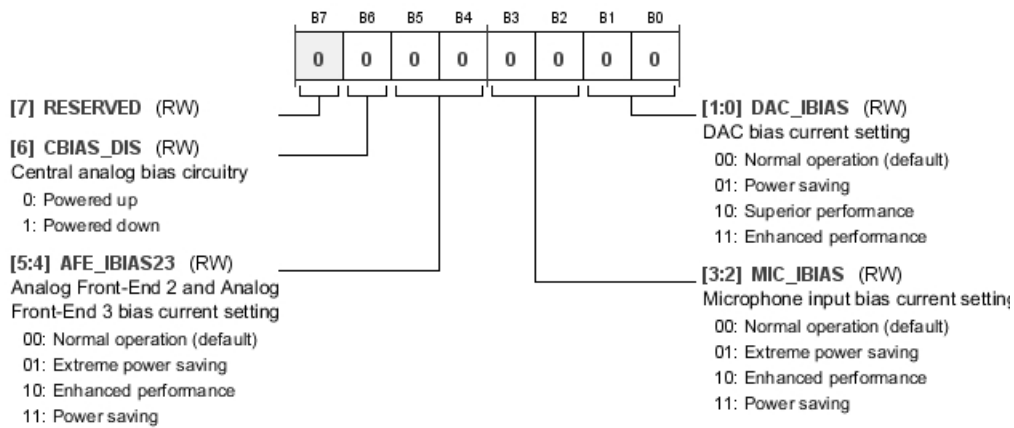

Table 98. Bit Descriptions for BIAS\_CONTROL1

Bits	Bit Name	Settings	Description	Reset	Access
6	CBIAS_DIS	0 1	Central analog bias circuitry. Higher bias currents result in higher performance. Powered up Powered down	0x0	RW

Bits	Bit Name	Settings	Description	Reset	Access
[5:4]	AFE_IBIAS23	00 01 10 11	Analog Front-End 2 and Analog Front-End 3 bias current setting. Higher bias currents result in higher performance. Normal operation (default) Extreme power saving Enhanced performance Power saving	0x0	RW
[3:2]	MIC_IBIAS	00 01 10 11	Microphone input bias current setting. Higher bias currents result in higher performance. Normal operation (default) Extreme power saving Enhanced performance Power saving	0x0	RW
[1:0]	DAC_IBIAS	00 01 10 11	DAC bias current setting. Higher bias currents result in higher performance. Normal operation (default) Power saving Superior performance Enhanced performance	0x0	RW

**DIGITAL PIN PULL-UP CONTROL 0 REGISTER**

Address: 0x0048, Reset: 0x7E, Name: PAD\_CONTROLO

Controls the behavior of the pad. Possible to enable pull-up.

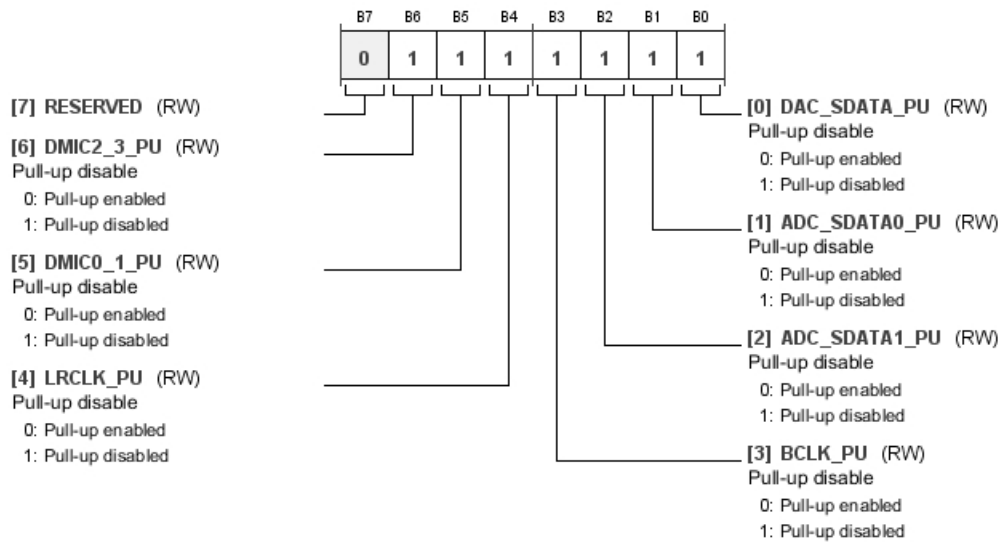

Table 99. Bit Descriptions for PAD\_CONTROLO

Bits	Bit Name	Settings	Description	Reset	Access
6	DMIC2_3_PU	0 1	Pull-up disable. Pull-up enabled Pull-up disabled	0x1	RW
5	DMIC0_1_PU	0 1	Pull-up disable. Pull-up enabled Pull-up disabled	0x1	RW
4	LRCLK_PU	0 1	Pull-up disable. Pull-up enabled Pull-up disabled	0x1	RW

Bits	Bit Name	Settings	Description	Reset	Access
3	BCLK_PU	0 1	Pull-up disable. Pull-up enabled Pull-up disabled	0x1	RW
2	ADC_SDATA1_PU	0 1	Pull-up disable. Pull-up enabled Pull-up disabled	0x1	RW
1	ADC_SDATA0_PU	0 1	Pull-up disable. Pull-up enabled Pull-up disabled	0x1	RW
0	DAC_SDATA_PU	0 1	Pull-up disable. Pull-up enabled Pull-up disabled	0x1	RW

### DIGITAL PIN PULL-UP CONTROL 1 REGISTER

Address: 0x0049, Reset: 0x1F, Name: PAD\_CONTROL1

Controls the behavior of the pad. Possible to enable pull-up.

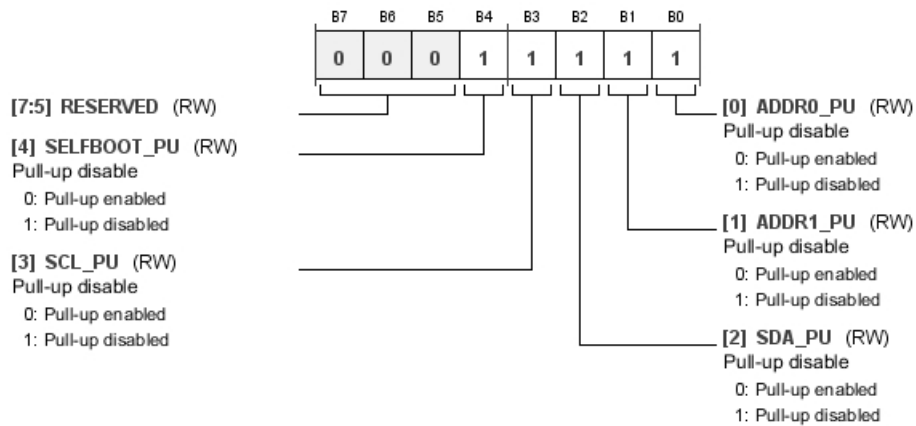

Table 100. Bit Descriptions for PAD\_CONTROL1

Bits	Bit Name	Settings	Description	Reset	Access
4	SELFBOOT_PU	0 1	Pull-up disable. Pull-up enabled Pull-up disabled	0x1	RW
3	SCL_PU	0 1	Pull-up disable. Pull-up enabled Pull-up disabled	0x1	RW
2	SDA_PU	0 1	Pull-up disable. Pull-up enabled Pull-up disabled	0x1	RW
1	ADDR1_PU	0 1	Pull-up disable. Pull-up enabled Pull-up disabled	0x1	RW
0	ADDR0_PU	0 1	Pull-up disable. Pull-up enabled Pull-up disabled	0x1	RW

**DIGITAL PIN PULL-DOWN CONTROL 0 REGISTER**

Address: 0x004A, Reset: 0x00, Name: PAD\_CONTROL2

Controls the behavior of the pad. Possible to enable pull-down.

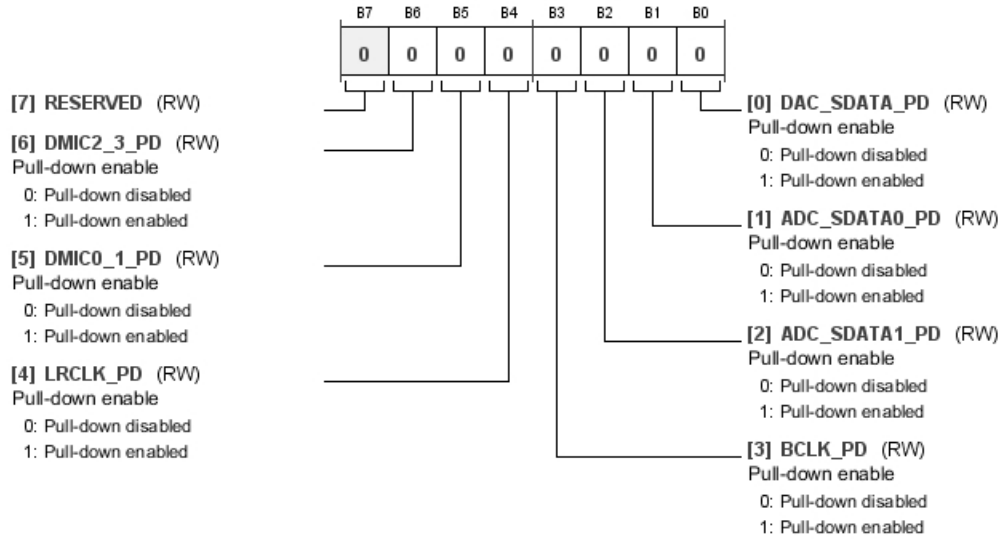

Table 101. Bit Descriptions for PAD\_CONTROL2

Bits	Bit Name	Settings	Description	Reset	Access
6	DMIC2_3_PD	0 1	Pull-down enable. Pull-down disabled Pull-down enabled	0x0	RW
5	DMIC0_1_PD	0 1	Pull-down enable. Pull-down disabled Pull-down enabled	0x0	RW
4	LRCLK_PD	0 1	Pull-down enable. Pull-down disabled Pull-down enabled	0x0	RW
3	BCLK_PD	0 1	Pull-down enable. Pull-down disabled Pull-down enabled	0x0	RW
2	ADC_SDATA1_PD	0 1	Pull-down enable. Pull-down disabled Pull-down enabled	0x0	RW
1	ADC_SDATA0_PD	0 1	Pull-down enable. Pull-down disabled Pull-down enabled	0x0	RW
0	DAC_SDATA_PD	0 1	Pull-down enable. Pull-down disabled Pull-down enabled	0x0	RW

**DIGITAL PIN PULL-DOWN CONTROL 1 REGISTER**

Address: 0x004B, Reset: 0x00, Name: PAD\_CONTROL3

Controls the behavior of the pad. Possible to enable pull-down.

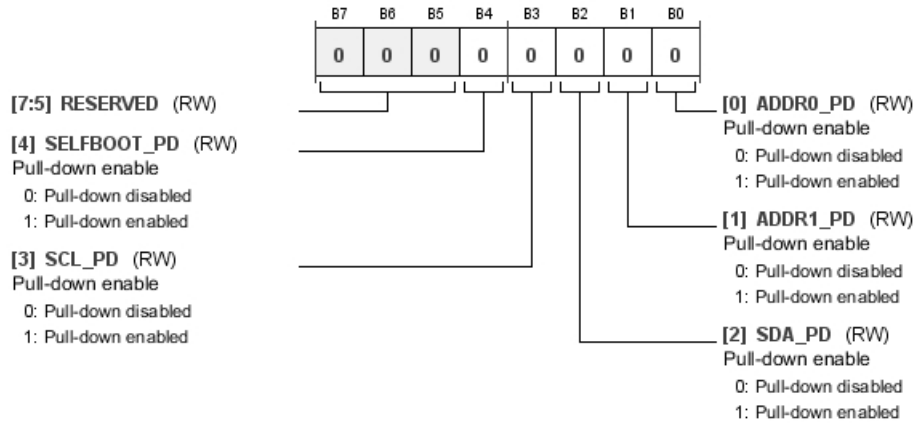

Table 102. Bit Descriptions for PAD\_CONTROL3

Bits	Bit Name	Settings	Description	Reset	Access
4	SELFBOOT_PD	0 1	Pull-down enable. Pull-down disabled Pull-down enabled	0x0	RW
3	SCL_PD	0 1	Pull-down enable. Pull-down disabled Pull-down enabled	0x0	RW
2	SDA_PD	0 1	Pull-down enable. Pull-down disabled Pull-down enabled	0x0	RW
1	ADDR1_PD	0 1	Pull-down enable. Pull-down disabled Pull-down enabled	0x0	RW
0	ADDR0_PD	0 1	Pull-down enable. Pull-down disabled Pull-down enabled	0x0	RW

**DIGITAL PIN DRIVE STRENGTH CONTROL 0 REGISTER**

Address: 0x004C, Reset: 0x00, Name: PAD\_CONTROL4

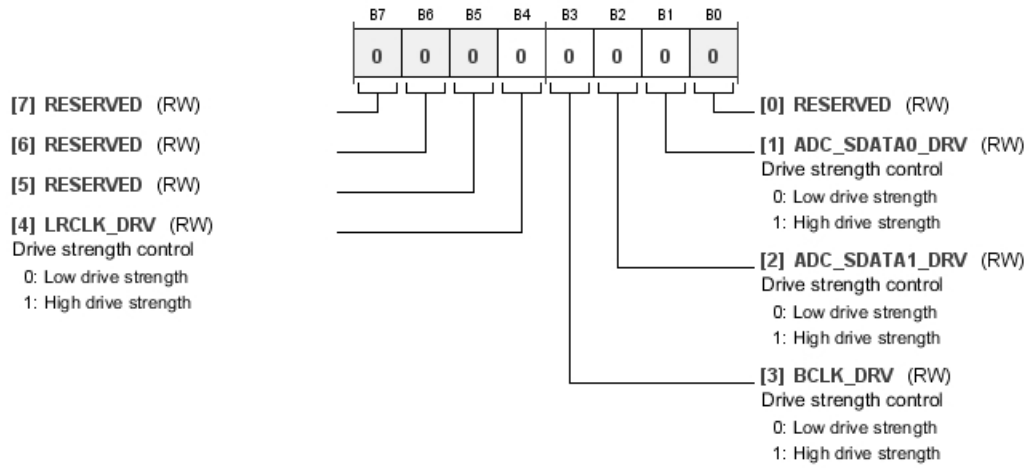

Table 103. Bit Descriptions for PAD\_CONTROL4

Bits	Bit Name	Settings	Description	Reset	Access
4	LRCLK_DRV	0 1	Drive strength control. Low drive strength High drive strength	0x0	RW
3	BCLK_DRV	0 1	Drive strength control. Low drive strength High drive strength	0x0	RW
2	ADC_SDATA1_DRV	0 1	Drive strength control. Low drive strength High drive strength	0x0	RW
1	ADC_SDATA0_DRV	0 1	Drive strength control. Low drive strength High drive strength	0x0	RW

**DIGITAL PIN DRIVE STRENGTH CONTROL 1 REGISTER**

Address: 0x004D, Reset: 0x00, Name: PAD\_CONTROL5

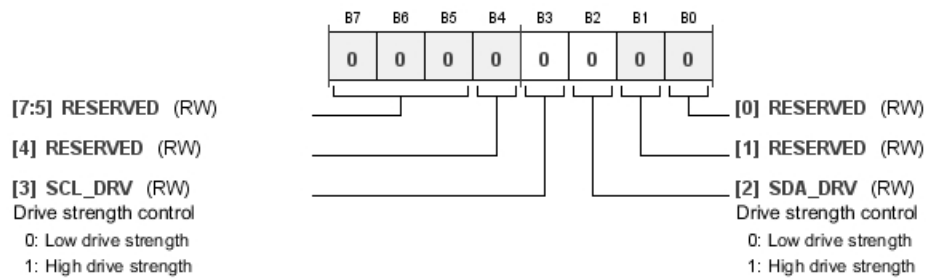
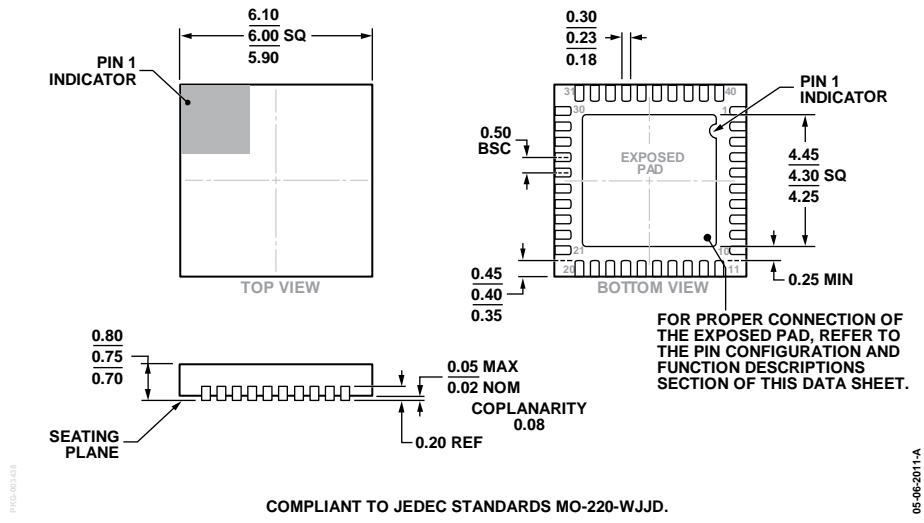

Table 104. Bit Descriptions for PAD\_CONTROL5

Bits	Bit Name	Settings	Description	Reset	Access
3	SCL_DRV	0 1	Drive strength control. Low drive strength High drive strength	0x0	RW
2	SDA_DRV	0 1	Drive strength control. Low drive strength High drive strength	0x0	RW

OUTLINE DIMENSIONS



COMPLIANT TO JEDEC STANDARDS MO-220-WJJD.

Figure 105. 40-Lead Lead Frame Chip Scale Package [LFCSP\_WQ]  
 6 mm × 6 mm Body, Very Very Thin Quad  
 (CP-40-10)  
 Dimension shown in millimeters

ORDERING GUIDE

Model <sup>1</sup>	Temperature Range	Package Description	Package Option
ADAU1772BCPZ	-40°C to +85°C	40-Lead Lead Frame Chip Scale Package [LFCSP_WQ]	CP-40-10
ADAU1772BCPZ-R7	-40°C to +85°C	40-Lead Lead Frame Chip Scale Package [LFCSP_WQ], 7" Tape and Reel	CP-40-10
ADAU1772BCPZ-RL	-40°C to +85°C	40-Lead Lead Frame Chip Scale Package [LFCSP_WQ], 13" Tape and Reel	CP-40-10
EVAL-ADAU1772Z		Evaluation Board	

<sup>1</sup> Z = RoHS Compliant Part.

**NOTES**

**NOTES**

## Looking for pricing, stock, or lifecycle information?

Click below to explore more details on WIN SOURCE:

 [View ADAU1772BCPZ-RL on WIN SOURCE](#)

 [Analog Devices Inc. Information](#)

## Optimize Your Supply Chain with WIN SOURCE Solutions

-  Global Sourcing Solution
-  Obsolete Management
-  Cost Control Management
-  Shortage Management
-  Alternative Solution
-  Excess Inventory Management