



**THE DATASHEET OF
ADG5207BCPZ-RL7**



FEATURES

Latch-up proof

3.5 pF off source capacitance

Off drain capacitance

ADG5206: 64 pF

ADG5207: 33 pF

0.35 pC typical charge injection

±0.02 nA on channel leakage

Low on resistance: 155 Ω typical

±9 V to ±22 V dual-supply operation

9 V to 40 V single-supply operation

V_{SS} to V_{DD} analog signal range

Human body model (HBM) ESD rating

ADG5206: 8 kV all pins

ADG5207: 8 kV I/O port to supplies

APPLICATIONS

Automatic test equipment

Data acquisition

Instrumentation

Avionics

Battery monitoring

Communication systems

GENERAL DESCRIPTION

The **ADG5206** and **ADG5207** are monolithic CMOS analog multiplexers comprising 16 single channels and 8 differential channels, respectively. The **ADG5206** switches one of sixteen inputs to a common output, as determined by the 4-bit binary address lines, A0, A1, A2, and A3. The **ADG5207** switches one of eight differential inputs to a common differential output, as determined by the 3-bit binary address lines, A0, A1, and A2.

An EN input on both devices enables or disables the device. When EN is low, the device is disabled and all channels switch off. The ultralow capacitance and charge injection of these switches make them ideal solutions for data acquisition and sample-and-hold applications, where low glitch and fast settling are required. Fast switching speed coupled with high signal bandwidth make these devices suitable for video signal switching.

Each switch conducts equally well in both directions when on, and each switch has an input signal range that extends to the power supplies. In the off condition, signal levels up to the supplies are blocked.

Rev. A

[Document Feedback](#)

Information furnished by Analog Devices is believed to be accurate and reliable. However, no responsibility is assumed by Analog Devices for its use, nor for any infringements of patents or other rights of third parties that may result from its use. Specifications subject to change without notice. No license is granted by implication or otherwise under any patent or patent rights of Analog Devices. Trademarks and registered trademarks are the property of their respective owners.

FUNCTIONAL BLOCK DIAGRAMS

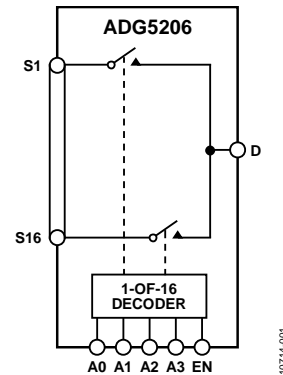

Figure 1.

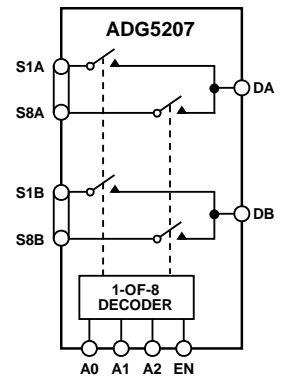

Figure 2.

The **ADG5206/ADG5207** do not have V_L pins; instead, an on-chip voltage generator generates the logic power supply internally.

PRODUCT HIGHLIGHTS

1. Trench Isolation Guards Against Latch-Up. A dielectric trench separates the P and N channel transistors to prevent latch-up even under severe overvoltage conditions.
2. Optimal switch design for low charge injection, low switch capacitance, and low leakage currents.
3. The **ADG5206** achieves 8 kV HBM ESD specification on all external pins, while the **ADG5207** achieves 8 kV on the I/O port to supply pins, 2 kV on the I/O port to I/O port pins, and 8 kV on all other pins.
4. Dual-Supply Operation. For applications where the analog signal is bipolar, the **ADG5206/ADG5207** can be operated from dual supplies of up to ±22 V.
5. Single-Supply Operation. For applications where the analog signal is unipolar, the **ADG5206/ADG5207** can be operated from a single rail power supply of up to 40 V.

TABLE OF CONTENTS

Features	1	Absolute Maximum Ratings	11
Applications.....	1	ESD Caution.....	11
Functional Block Diagrams.....	1	Pin Configurations and Function Descriptions	12
General Description	1	Typical Performance Characteristics	16
Product Highlights	1	Test Circuits.....	21
Revision History	2	Terminology	23
Specifications.....	3	Applications Information	24
±15 V Dual Supply	3	Trench Isolation.....	24
±20 V Dual Supply	4	Outline Dimensions	25
12 V Single Supply.....	6	Ordering Guide	25
36 V Single Supply.....	8		
Continuous Current per Channel, Sx, D, or Dx.....	10		

REVISION HISTORY

5/13—Rev. 0 to Rev. A

Added 32-Lead LFCSP	Universal
Changes to Features Section and Product Highlights Section.....	1
Moved Continuous Current per Channel, Sx, D, or Dx Section, Table 5, and Table 6	10
Changes to Table 7.....	11
Changes to Figure 3.....	12
Changes to Figure 5.....	13
Changes to Figure 30, Figure 32, and Figure 33.....	22

7/12—Revision 0: Initial Version

SPECIFICATIONS

±15 V DUAL SUPPLY

$V_{DD} = +15\text{ V} \pm 10\%$, $V_{SS} = -15\text{ V} \pm 10\%$, $GND = 0\text{ V}$, unless otherwise noted.

Table 1.

Parameter	25°C	-40°C to +60°C	-40°C to +85°C	-40°C to +125°C	Unit	Test Conditions/Comments
ANALOG SWITCH						
Analog Signal Range				V_{DD} to V_{SS}	V	
On Resistance, R_{ON}	155				Ω typ	$V_S = \pm 10\text{ V}$, $I_S = -1\text{ mA}$; see Figure 32
On Resistance Match Between Channels, ΔR_{ON}	200	225	250	285	Ω max	$V_{DD} = +13.5\text{ V}$, $V_{SS} = -13.5\text{ V}$
	4				Ω typ	$V_S = \pm 10\text{ V}$, $I_S = -1\text{ mA}$
On Resistance Flatness, $R_{FLAT(ON)}$	12	13	14	15	Ω max	
	48				Ω typ	$V_S = \pm 10\text{ V}$, $I_S = -1\text{ mA}$
	65	73	80	90	Ω max	
LEAKAGE CURRENTS						
Source Off Leakage, I_S (Off)	± 0.005				nA typ	$V_{DD} = +16.5\text{ V}$, $V_{SS} = -16.5\text{ V}$ $V_S = \pm 10\text{ V}$, $V_D = \mp 10\text{ V}$; see Figure 33
Match Between Channels, Δ Leakage, I_S (Off) ¹	± 0.1	± 0.15	± 0.2	± 0.4	nA max	
Drain Off Leakage, I_D (Off)	0.01			0.015	nA typ	$V_S = \pm 10\text{ V}$, $V_D = \mp 10\text{ V}$
						$V_S = \pm 10\text{ V}$, $V_D = \mp 10\text{ V}$; see Figure 33
ADG5206	± 0.02				nA typ	
ADG5207	± 0.1	± 0.25	± 0.6	± 3.3	nA max	
Match Between Channels, Δ Leakage, I_D (Off), ADG5207 Only	± 0.02				nA typ	
Channel On Leakage, I_D (On), I_S (On)	± 0.1	± 0.25	± 0.4	± 1.7	nA max	$V_S = \pm 10\text{ V}$, $V_D = \mp 10\text{ V}$
ADG5206	0.015			0.015	nA typ	
ADG5207	± 0.02				nA typ	$V_S = V_D = \pm 10\text{ V}$; see Figure 34
	± 0.1	± 0.25	± 0.6	± 3.3	nA max	
Match Between Channels, Δ Leakage, I_D (On), I_S (On) ²	± 0.02				nA typ	
	± 0.1	± 0.25	± 0.6	± 3.3	nA max	
	± 0.02				nA typ	
	± 0.1	± 0.2	± 0.4	± 1.7	nA max	
	0.01			0.03	nA typ	$V_S = V_D = \pm 10\text{ V}$
DIGITAL INPUTS						
Input High Voltage, V_{INH}				2.0	V min	
Input Low Voltage, V_{INL}				0.8	V max	
Input Current, I_{INL} or I_{INH}	0.002				μA typ	$V_{IN} = V_{GND}$ or V_{DD}
				± 0.1	μA max	
Digital Input Capacitance, C_{IN}	3				pF typ	
DYNAMIC CHARACTERISTICS³						
Transition Time, $t_{TRANSITION}$	200				ns typ	$R_L = 300\ \Omega$, $C_L = 35\text{ pF}$
	260	300	320	360	ns max	$V_S = 10\text{ V}$; see Figure 35
t_{ON} (EN)	180				ns typ	$R_L = 300\ \Omega$, $C_L = 35\text{ pF}$
	245	260	270	285	ns max	$V_S = 10\text{ V}$; see Figure 36
t_{OFF} (EN)	140				ns typ	$R_L = 300\ \Omega$, $C_L = 35\text{ pF}$
	200	220	240	270	ns max	$V_S = 10\text{ V}$; see Figure 36
Break-Before-Make Time Delay, t_D	85				ns typ	$R_L = 300\ \Omega$, $C_L = 35\text{ pF}$
				27	ns min	$V_{S1} = V_{S2} = 10\text{ V}$; see Figure 37

Parameter	25°C	-40°C to +60°C	-40°C to +85°C	-40°C to +125°C	Unit	Test Conditions/Comments
Charge Injection, Q_{INJ}	0.35				pC typ	$V_S = 0\text{ V}$, $R_S = 0\ \Omega$, $C_L = 1\text{ nF}$; see Figure 38
Off Isolation	± 1.8 -90			± 2	pC typ dB typ	$V_S = \pm 10\text{ V}$, $R_S = 0\ \Omega$, $C_L = 1\text{ nF}$ $R_L = 50\ \Omega$, $C_L = 5\text{ pF}$, $f = 1\text{ MHz}$; see Figure 39
Channel-to-Channel Crosstalk	-76				dB typ	$R_L = 50\ \Omega$, $C_L = 5\text{ pF}$, $f = 1\text{ MHz}$; see Figure 40
-3 dB Bandwidth						$R_L = 50\ \Omega$, $C_L = 5\text{ pF}$; see Figure 41
ADG5206	60				MHz typ	
ADG5207	140				MHz typ	
Insertion Loss	6.4				dB typ	$R_L = 50\ \Omega$, $C_L = 5\text{ pF}$, $f = 1\text{ MHz}$; see Figure 41
C_S (Off)	3.5				pF typ	$V_S = 0\text{ V}$, $f = 1\text{ MHz}$
C_D (Off)						
ADG5206	64				pF typ	$V_S = 0\text{ V}$, $f = 1\text{ MHz}$
ADG5207	33				pF typ	$V_S = 0\text{ V}$, $f = 1\text{ MHz}$
C_D (On), C_S (On)						
ADG5206	68				pF typ	$V_S = 0\text{ V}$, $f = 1\text{ MHz}$
ADG5207	36				pF typ	$V_S = 0\text{ V}$, $f = 1\text{ MHz}$
POWER REQUIREMENTS						
I_{DD}	45				$\mu\text{A typ}$	$V_{DD} = +16.5\text{ V}$, $V_{SS} = -16.5\text{ V}$ Digital inputs = 0 V or V_{DD}
	55			70	$\mu\text{A max}$	
I_{SS}	0.001				$\mu\text{A typ}$	Digital inputs = 0 V or V_{DD}
				1	$\mu\text{A max}$	
V_{DD}/V_{SS}				$\pm 9/\pm 22$	V min/V max	GND = 0 V

¹ The off channel leakage delta is calculated using the maximum of $V_S = +10\text{ V}$ and $V_D = -10\text{ V}$, or $V_S = -10\text{ V}$ and $V_D = +10\text{ V}$.

² The on channel leakage delta is calculated using the maximum of $V_S = V_D = +10\text{ V}$, or $V_S = V_D = -10\text{ V}$.

³ Guaranteed by design; not subject to production test.

±20 V DUAL SUPPLY

$V_{DD} = +20\text{ V} \pm 10\%$, $V_{SS} = -20\text{ V} \pm 10\%$, GND = 0 V, unless otherwise noted.

Table 2.

Parameter	25°C	-40°C to +60°C	-40°C to +85°C	-40°C to +125°C	Unit	Test Conditions/Comments
ANALOG SWITCH						
Analog Signal Range				V_{DD} to V_{SS}	V	
On Resistance, R_{ON}	130				Ω typ	$V_S = \pm 15\text{ V}$, $I_S = -1\text{ mA}$; see Figure 32
	160	180	200	230	Ω max	$V_{DD} = +18\text{ V}$, $V_{SS} = -18\text{ V}$
On-Resistance Match Between Channels, ΔR_{ON}	4				Ω typ	$V_S = \pm 15\text{ V}$, $I_S = -1\text{ mA}$
	12	13	14	15	Ω max	
On-Resistance Flatness, $R_{FLAT(ON)}$	35				Ω typ	$V_S = \pm 15\text{ V}$, $I_S = -1\text{ mA}$
	50	58	65	75	Ω max	

Parameter	25°C	-40°C to +60°C	-40°C to +85°C	-40°C to +125°C	Unit	Test Conditions/Comments
LEAKAGE CURRENTS						
Source Off Leakage, I_s (Off)	±0.005				nA typ	$V_{DD} = +22\text{ V}$, $V_{SS} = -22\text{ V}$ $V_S = \pm 15\text{ V}$, $V_D = \mp 15\text{ V}$; see Figure 33
Match Between Channels, Δ Leakage, I_s (Off) ¹	±0.1	±0.15	±0.2	±0.4	nA max	
Drain Off Leakage, I_D (Off)	0.01			0.015	nA typ	$V_S = \pm 15\text{ V}$, $V_D = \mp 15\text{ V}$; see Figure 33
ADG5206	±0.02				nA typ	
ADG5207	±0.1	±0.25	±0.6	±3.3	nA max	
Match Between Channels, Δ Leakage, I_D (Off), ADG5207 Only	±0.02				nA typ	
Channel On Leakage, I_D (On), I_s (On)	±0.1	±0.25	±0.4	±1.7	nA max	$V_S = V_D = \pm 15\text{ V}$; see Figure 34
ADG5206	0.015			0.015	nA typ	
ADG5207	±0.02				nA typ	
Match Between Channels, Δ Leakage, I_D (On), I_s (On) ²	±0.1	±0.25	±0.6	±3.3	nA max	
ADG5207	±0.02				nA typ	
Match Between Channels, Δ Leakage, I_D (On), I_s (On) ²	±0.1	±0.2	±0.4	±1.7	nA max	
0.01				0.03	nA typ	
DIGITAL INPUTS						
Input High Voltage, V_{INH}				2.0	V min	
Input Low Voltage, V_{INL}				0.8	V max	
Input Current, I_{INL} or I_{INH}	±0.002				μA typ	$V_{IN} = V_{GND}$ or V_{DD}
				±0.1	μA max	
Digital Input Capacitance, C_{IN}	3				pF typ	
DYNAMIC CHARACTERISTICS³						
Transition Time, $t_{TRANSITION}$	185				ns typ	$R_L = 300\ \Omega$, $C_L = 35\text{ pF}$
	240	270	290	320	ns max	$V_S = 10\text{ V}$; see Figure 35
t_{ON} (EN)	175				ns typ	$R_L = 300\ \Omega$, $C_L = 35\text{ pF}$
	230	245	255	270	ns max	$V_S = 10\text{ V}$; see Figure 36
t_{OFF} (EN)	135				ns typ	$R_L = 300\ \Omega$, $C_L = 35\text{ pF}$
	185	205	220	245	ns max	$V_S = 10\text{ V}$; see Figure 36
Break-Before-Make Time Delay, t_D	75				ns typ	$R_L = 300\ \Omega$, $C_L = 35\text{ pF}$
				27	ns min	$V_{S1} = V_{S2} = 10\text{ V}$; see Figure 37
Charge Injection, Q_{INU}	0.45				pC typ	$V_S = 0\text{ V}$, $R_S = 0\ \Omega$, $C_L = 1\text{ nF}$; see Figure 38
	±4			±4	pC typ	$V_S = \pm 10\text{ V}$, $R_S = 0\ \Omega$, $C_L = 1\text{ nF}$
Off Isolation	-90				dB typ	$R_L = 50\ \Omega$, $C_L = 5\text{ pF}$, $f = 1\text{ MHz}$; see Figure 39
Channel-to-Channel Crosstalk	-76				dB typ	$R_L = 50\ \Omega$, $C_L = 5\text{ pF}$, $f = 1\text{ MHz}$; see Figure 40
-3 dB Bandwidth						$R_L = 50\ \Omega$, $C_L = 5\text{ pF}$; see Figure 41
ADG5206	65				MHz typ	
ADG5207	145				MHz typ	
Insertion Loss	5.6				dB typ	$R_L = 50\ \Omega$, $C_L = 5\text{ pF}$, $f = 1\text{ MHz}$; see Figure 41
C_S (Off)	3.3				pF typ	$V_S = 0\text{ V}$, $f = 1\text{ MHz}$

Parameter	25°C	-40°C to +60°C	-40°C to +85°C	-40°C to +125°C	Unit	Test Conditions/Comments
	C _D (Off) ADG5206 ADG5207	62 32				
C _D (On), C _S (On) ADG5206 ADG5207	67 35				pF typ pF typ	V _S = 0 V, f = 1 MHz V _S = 0 V, f = 1 MHz
POWER REQUIREMENTS						
I _{DD}	50 70			110	μA typ μA max	V _{DD} = +22 V, V _{SS} = -22 V Digital inputs = 0 V or V _{DD}
I _{SS}	0.001			1	μA typ μA max	Digital inputs = 0 V or V _{DD}
V _{DD} /V _{SS}				±9/±22	V min/V max	GND = 0 V

¹ The off channel leakage delta is calculated using the maximum of V_S = +15 V and V_D = -15 V, or V_S = -15 V and V_D = +15 V.

² The on channel leakage delta is calculated using the maximum of V_S = V_D = +15 V, or V_S = V_D = -15 V.

³ Guaranteed by design; not subject to production test.

12 V SINGLE SUPPLY

V_{DD} = 12 V ± 10%, V_{SS} = 0 V, GND = 0 V, unless otherwise noted.

Table 3.

Parameter	25°C	-40°C to +60°C	-40°C to +85°C	-40°C to +125°C	Unit	Test Conditions/Comments
	ANALOG SWITCH					
Analog Signal Range				0 V to V _{DD}	V	
On Resistance, R _{ON}	350				Ω typ	V _S = 0 V to 10 V, I _S = -1 mA; see Figure 32
On-Resistance Match Between Channels, ΔR _{ON}	5	500	610	700	Ω max Ω typ	V _{DD} = 10.8 V, V _{SS} = 0 V V _S = 0 V to 10 V, I _S = -1 mA
On-Resistance Flatness, R _{FLAT (ON)}	20	21	22	24	Ω max Ω typ	V _S = 0 V to 10 V, I _S = -1 mA
	280	310	335	370	Ω max	
LEAKAGE CURRENTS						
Source Off Leakage, I _S (Off)	±0.005				nA typ	V _{DD} = +13.2 V, V _{SS} = 0 V V _S = 1 V/10 V, V _D = 10 V/1 V; see Figure 33
Match Between Channels, ΔLeakage, I _S (Off) ¹	±0.1	±0.15	±0.2	±0.4	nA max nA typ	
Drain Off Leakage, I _D (Off)						V _S = 1 V/10 V, V _D = 1 V/10 V; see Figure 33
ADG5206	±0.02				nA typ nA max	
ADG5207	±0.1	±0.25	±0.6	±3.3	nA typ nA max	
Match Between Channels, ΔLeakage, I _D (Off), ADG5207 Only	±0.02	±0.1	±0.25	±0.4	nA typ nA max	
Channel On Leakage, I _D (On), I _S (On)	0.015			0.015	nA typ	V _S = V _D = 1 V/10 V; see Figure 34
ADG5206	±0.02				nA typ nA max	
ADG5207	±0.1	±0.25	±0.6	±3.3	nA typ nA max	
Match Between Channels, ΔLeakage, I _D (On), I _S (On) ²	±0.02	±0.1	±0.25	±0.4	nA typ nA max	
	±0.1	±0.2	±0.4	±1.7	nA max nA typ	

Parameter	25°C	-40°C to +60°C	-40°C to +85°C	-40°C to +125°C	Unit	Test Conditions/Comments
DIGITAL INPUTS						
Input High Voltage, V_{INH}				2.0	V min	$V_{IN} = V_{GND}$ or V_{DD}
Input Low Voltage, V_{INL}				0.8	V max	
Input Current, I_{INL} or I_{INH}	0.002				μA typ	
Digital Input Capacitance, C_{IN}	3			± 0.1	μA max pF typ	
DYNAMIC CHARACTERISTICS³						
Transition Time, $t_{TRANSITION}$	290				ns typ	$R_L = 300 \Omega$, $C_L = 35 \text{ pF}$
	290	440	480	550	ns max	$V_S = 8 \text{ V}$; see Figure 35
t_{ON} (EN)	230				ns typ	$R_L = 300 \Omega$, $C_L = 35 \text{ pF}$
	290	320	340	370	ns max	$V_S = 8 \text{ V}$; see Figure 36
t_{OFF} (EN)	230				ns typ	$R_L = 300 \Omega$, $C_L = 35 \text{ pF}$
	315	360	390	450	ns max	$V_S = 8 \text{ V}$; see Figure 36
Break-Before-Make Time Delay, t_D	170				ns typ	$R_L = 300 \Omega$, $C_L = 35 \text{ pF}$
				45	ns min	$V_{S1} = V_{S2} = 8 \text{ V}$; see Figure 37
Charge Injection, Q_{INJ}	0.25				pC typ	$V_S = 6 \text{ V}$, $R_S = 0 \Omega$, $C_L = 1 \text{ nF}$; see Figure 38
	± 0.6			± 0.7	pC typ	$V_S = 0 \text{ V}$ to 10 V , $R_S = 0 \Omega$, $C_L = 1 \text{ nF}$
Off Isolation	-90				dB typ	$R_L = 50 \Omega$, $C_L = 5 \text{ pF}$, $f = 1 \text{ MHz}$; see Figure 39
Channel-to-Channel Crosstalk	-76				dB typ	$R_L = 50 \Omega$, $C_L = 5 \text{ pF}$, $f = 1 \text{ MHz}$; see Figure 40
-3 dB Bandwidth						$R_L = 50 \Omega$, $C_L = 5 \text{ pF}$; see Figure 41
ADG5206	50				MHz typ	
ADG5207	105				MHz typ	
Insertion Loss	8.55				dB typ	$R_L = 50 \Omega$, $C_L = 5 \text{ pF}$, $f = 1 \text{ MHz}$; see Figure 41
C_S (Off)	3.6				pF typ	$V_S = 6 \text{ V}$, $f = 1 \text{ MHz}$
C_D (Off)						
ADG5206	71				pF typ	$V_S = 6 \text{ V}$, $f = 1 \text{ MHz}$
ADG5207	36				pF typ	$V_S = 6 \text{ V}$, $f = 1 \text{ MHz}$
C_D (On), C_S (On)						
ADG5206	75				pF typ	$V_S = 6 \text{ V}$, $f = 1 \text{ MHz}$
ADG5207	40				pF typ	$V_S = 6 \text{ V}$, $f = 1 \text{ MHz}$
POWER REQUIREMENTS						
I_{DD}	40				μA typ	$V_{DD} = 13.2 \text{ V}$
	50			65	μA max	Digital inputs = 0 V or V_{DD}
V_{DD}				9/40	V min/V max	$GND = 0 \text{ V}$, $V_{SS} = 0 \text{ V}$

¹ The off channel leakage delta is calculated using the maximum of $V_S = 1 \text{ V}$ and $V_D = 10 \text{ V}$, or $V_S = 10 \text{ V}$ and $V_D = 1 \text{ V}$.

² The on channel leakage delta is calculated using the maximum of $V_S = V_D = 1 \text{ V}$, or $V_S = V_D = 10 \text{ V}$.

³ Guaranteed by design; not subject to production test.

36 V SINGLE SUPPLY

$V_{DD} = 36\text{ V} \pm 10\%$, $V_{SS} = 0\text{ V}$, $GND = 0\text{ V}$, unless otherwise noted.

Table 4.

Parameter	25°C	-40°C to +60°C	-40°C to +85°C	-40°C to +125°C	Unit	Test Conditions/Comments
ANALOG SWITCH						
Analog Signal Range				0 V to V_{DD}	V	
On Resistance, R_{ON}	140				Ω typ	$V_S = 0\text{ V to }30\text{ V}$, $I_S = -1\text{ mA}$; see Figure 32
On-Resistance Match Between Channels, ΔR_{ON}	170	195	215	245	Ω max	$V_{DD} = 32.4\text{ V}$, $V_{SS} = 0\text{ V}$
	4				Ω typ	$V_S = 0\text{ V to }30\text{ V}$, $I_S = -1\text{ mA}$
On-Resistance Flatness, $R_{FLAT(ON)}$	12	13	14	15	Ω max	
	40				Ω typ	$V_S = 0\text{ V to }30\text{ V}$, $I_S = -1\text{ mA}$
	55	63	70	80	Ω max	
LEAKAGE CURRENTS						
Source Off Leakage, I_S (Off)	± 0.005				nA typ	$V_{DD} = 39.6\text{ V}$, $V_{SS} = 0\text{ V}$ $V_S = 1\text{ V}/30\text{ V}$, $V_D = 30\text{ V}/1\text{ V}$; see Figure 33
Match Between Channels, Δ Leakage, I_S (Off) ¹	± 0.1	± 0.15	± 0.2	± 0.4	nA max	
Drain Off Leakage, I_D (Off)	0.01			0.015	nA typ	$V_S = 1\text{ V}/30\text{ V}$, $V_D = 30\text{ V}/1\text{ V}$; see Figure 33
ADG5206	± 0.02				nA typ	
ADG5207	± 0.1	± 0.25	± 0.6	± 3.3	nA max	
Match Between Channels, Δ Leakage, I_D (Off), ADG5207 Only	± 0.02				nA typ	
Channel On Leakage, I_D (On), I_S (On)	± 0.1	± 0.25	± 0.4	± 1.7	nA max	
ADG5206	0.015			0.015	nA typ	$V_S = V_D = 1\text{ V}/30\text{ V}$; see Figure 34
ADG5207	± 0.02				nA typ	
	± 0.1	± 0.25	± 0.6	± 3.3	nA max	
ADG5207	± 0.02				nA typ	
Match Between Channels, Δ Leakage, I_D (On), I_S (On) ²	± 0.1	± 0.2	± 0.4	± 1.7	nA max	
	0.01			0.03	nA typ	
DIGITAL INPUTS						
Input High Voltage, V_{INH}				2.0	V min	
Input Low Voltage, V_{INL}				0.8	V max	
Input Current, I_{INL} or I_{INH}	0.002				μA typ	$V_{IN} = V_{GND}$ or V_{DD}
				± 0.1	μA max	
Digital Input Capacitance, C_{IN}	3				pF typ	
DYNAMIC CHARACTERISTICS³						
Transition Time, $t_{TRANSITION}$	225				ns typ	$R_L = 300\ \Omega$, $C_L = 35\text{ pF}$
	290	310	320	350	ns max	$V_S = 18\text{ V}$; see Figure 35
t_{ON} (EN)	215				ns typ	$R_L = 300\ \Omega$, $C_L = 35\text{ pF}$
	265	285	285	295	ns max	$V_S = 18\text{ V}$; see Figure 36
t_{OFF} (EN)	170				ns typ	$R_L = 300\ \Omega$, $C_L = 35\text{ pF}$
	215	230	245	270	ns max	$V_S = 18\text{ V}$; see Figure 36
Break-Before-Make Time Delay, t_D	90				ns typ	$R_L = 300\ \Omega$, $C_L = 35\text{ pF}$
				28	ns min	$V_{S1} = V_{S2} = 18\text{ V}$; see Figure 37
Charge Injection, Q_{INJ}	0.7				pC typ	$V_S = 18\text{ V}$, $R_S = 0\ \Omega$, $C_L = 1\text{ nF}$; see Figure 38
	± 3			± 3	pC typ	$V_S = 0\text{ V to }30\text{ V}$, $R_S = 0\ \Omega$, $C_L = 1\text{ nF}$

Parameter	25°C	-40°C to +60°C	-40°C to +85°C	-40°C to +125°C	Unit	Test Conditions/Comments
Off Isolation	-90				dB typ	$R_L = 50\ \Omega$, $C_L = 5\ \text{pF}$, $f = 1\ \text{MHz}$; see Figure 39
Channel-to-Channel Crosstalk	-76				dB typ	$R_L = 50\ \Omega$, $C_L = 5\ \text{pF}$, $f = 1\ \text{MHz}$; see Figure 40
-3 dB Bandwidth						$R_L = 50\ \Omega$, $C_L = 5\ \text{pF}$; see Figure 41
ADG5206	55				MHz typ	
ADG5207	115				MHz typ	
Insertion Loss	5.65				dB typ	$R_L = 50\ \Omega$, $C_L = 5\ \text{pF}$, $f = 1\ \text{MHz}$; see Figure 41
C_S (Off)	3.4				pF typ	$V_S = 18\ \text{V}$, $f = 1\ \text{MHz}$
C_D (Off)						
ADG5206	62				pF typ	$V_S = 18\ \text{V}$, $f = 1\ \text{MHz}$
ADG5207	32				pF typ	$V_S = 18\ \text{V}$, $f = 1\ \text{MHz}$
C_D (On), C_S (On)						
ADG5206	66				pF typ	$V_S = 18\ \text{V}$, $f = 1\ \text{MHz}$
ADG5207	35				pF typ	$V_S = 18\ \text{V}$, $f = 1\ \text{MHz}$
POWER REQUIREMENTS						
I_{DD}	80				μA typ	$V_{DD} = 39.6\ \text{V}$
	100			130	μA max	Digital inputs = 0 V or V_{DD}
V_{DD}				9/40	V min/V max	GND = 0 V, $V_{SS} = 0\ \text{V}$

¹ The off channel leakage delta is calculated using the maximum of $V_S = 1\ \text{V}$ and $V_D = 30\ \text{V}$, or $V_S = 30\ \text{V}$ and $V_D = 1\ \text{V}$.

² The on channel leakage delta is calculated using the maximum of $V_S = V_D = 1\ \text{V}$, or $V_S = V_D = 30\ \text{V}$.

³ Guaranteed by design; not subject to production test.

CONTINUOUS CURRENT PER CHANNEL, Sx, D, OR Dx

Table 5. ADG5206

Parameter	25°C	60°C	85°C	125°C	Unit
CONTINUOUS CURRENT, Sx OR D					
$V_{DD} = +15\text{ V}, V_{SS} = -15\text{ V}$					
TSSOP ($\theta_{JA} = 67.7^\circ\text{C/W}$)	44	32	23	12	mA maximum
LFCSP ($\theta_{JA} = 27.27^\circ\text{C/W}$)	62	42	28	13	mA maximum
$V_{DD} = +20\text{ V}, V_{SS} = -20\text{ V}$					
TSSOP ($\theta_{JA} = 67.7^\circ\text{C/W}$)	47	33	24	12	mA maximum
LFCSP ($\theta_{JA} = 27.27^\circ\text{C/W}$)	66	44	29	13	mA maximum
$V_{DD} = 12\text{ V}, V_{SS} = 0\text{ V}$					
TSSOP ($\theta_{JA} = 67.7^\circ\text{C/W}$)	31	24	19	11	mA maximum
LFCSP ($\theta_{JA} = 27.27^\circ\text{C/W}$)	45	33	24	12	mA maximum
$V_{DD} = 36\text{ V}, V_{SS} = 0\text{ V}$					
TSSOP ($\theta_{JA} = 67.7^\circ\text{C/W}$)	46	33	24	12	mA maximum
LFCSP ($\theta_{JA} = 27.27^\circ\text{C/W}$)	65	43	28	13	mA maximum

Table 6. ADG5207

Parameter	25°C	60°C	85°C	125°C	Unit
CONTINUOUS CURRENT, Sx OR Dx					
$V_{DD} = +15\text{ V}, V_{SS} = -15\text{ V}$					
TSSOP ($\theta_{JA} = 67.7^\circ\text{C/W}$)	33	25	19	11	mA maximum
LFCSP ($\theta_{JA} = 27.27^\circ\text{C/W}$)	48	34	24	12	mA maximum
$V_{DD} = +20\text{ V}, V_{SS} = -20\text{ V}$					
TSSOP ($\theta_{JA} = 67.7^\circ\text{C/W}$)	35	27	20	11	mA maximum
LFCSP ($\theta_{JA} = 27.27^\circ\text{C/W}$)	51	36	25	12	mA maximum
$V_{DD} = 12\text{ V}, V_{SS} = 0\text{ V}$					
TSSOP ($\theta_{JA} = 67.7^\circ\text{C/W}$)	23	19	15	12	mA maximum
LFCSP ($\theta_{JA} = 27.27^\circ\text{C/W}$)	34	26	20	12	mA maximum
$V_{DD} = 36\text{ V}, V_{SS} = 0\text{ V}$					
TSSOP ($\theta_{JA} = 67.7^\circ\text{C/W}$)	34	26	20	11	mA maximum
LFCSP ($\theta_{JA} = 27.27^\circ\text{C/W}$)	50	35	25	12	mA maximum

ABSOLUTE MAXIMUM RATINGS

T_A = 25°C, unless otherwise noted.

Table 7.

Parameter	Rating
V _{DD} to V _{SS}	48 V
V _{DD} to GND	−0.3 V to +48 V
V _{SS} to GND	+0.3 V to −48 V
Analog Inputs ¹	V _{SS} − 0.3 V to V _{DD} + 0.3 V or 30 mA, whichever occurs first
Digital Inputs ¹	V _{SS} − 0.3 V to V _{DD} + 0.3 V or 30 mA, whichever occurs first
Peak Current, Sx, D, or Dx Pins ADG5206	140 mA (pulsed at 1 ms, 10% duty cycle maximum)
ADG5207	105 mA (pulsed at 1 ms, 10% duty cycle maximum)
Continuous Current, Sx, D, or Dx Pins ²	Data + 15%
Temperature Range	
Operating	−40°C to +125°C
Storage	−65°C to +150°C
Junction Temperature	150°C
Thermal Impedance, θ _{JA}	
28-Lead TSSOP (4-Layer Board)	67.7°C/W
32-Lead LFCSP (4-Layer Board)	27.27°C/W
Reflow Soldering Peak Temperature, Pb Free	As per JEDEC J-STD-020
HBM ESD (ESDA/JEDEC JS-001-2011)	
ADG5206	
All Pins	8 kV
ADG5207	
I/O Port to Supplies	8 kV
I/O Port to I/O Port	2 kV
All Other Pins	8 kV

¹ Overvoltages at the Ax, EN, Sx, D, and Dx pins are clamped by internal diodes. Limit current to the maximum ratings given.

² See Table 5 and Table 6.

Stresses above those listed under Absolute Maximum Ratings may cause permanent damage to the device. This is a stress rating only; functional operation of the device at these or any other conditions above those indicated in the operational section of this specification is not implied. Exposure to absolute maximum rating conditions for extended periods may affect device reliability.

Only one absolute maximum rating can be applied at any one time.

ESD CAUTION



ESD (electrostatic discharge) sensitive device.

Charged devices and circuit boards can discharge without detection. Although this product features patented or proprietary protection circuitry, damage may occur on devices subjected to high energy ESD. Therefore, proper ESD precautions should be taken to avoid performance degradation or loss of functionality.

PIN CONFIGURATIONS AND FUNCTION DESCRIPTIONS

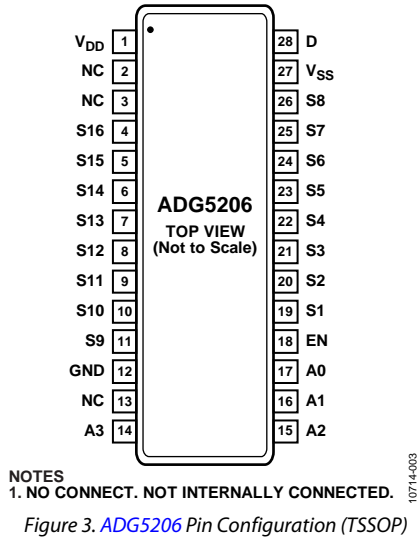

Figure 3. ADG5206 Pin Configuration (TSSOP)

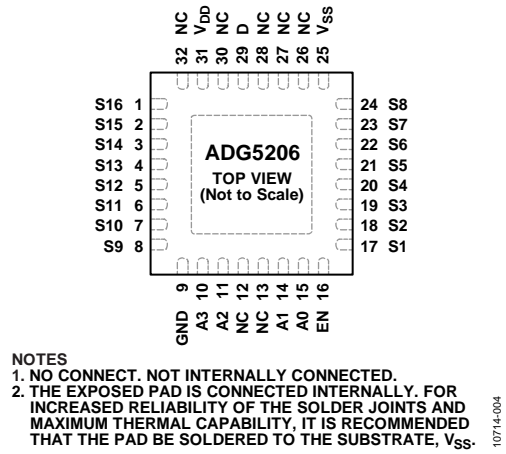

Figure 4. ADG5206 Pin Configuration (LFCSP)

Table 8. ADG5206 Pin Function Descriptions

Pin No.		Mnemonic	Description
TSSOP	LFCSP		
1	31	V _{DD}	Most Positive Power Supply Potential.
2, 3, 13	12, 13, 26, 27, 28, 30, 32	NC	No Connect. Not internally connected.
4	1	S16	Source Terminal 16. This pin can be an input or an output.
5	2	S15	Source Terminal 15. This pin can be an input or an output.
6	3	S14	Source Terminal 14. This pin can be an input or an output.
7	4	S13	Source Terminal 13. This pin can be an input or an output.
8	5	S12	Source Terminal 12. This pin can be an input or an output.
9	6	S11	Source Terminal 11. This pin can be an input or an output.
10	7	S10	Source Terminal 10. This pin can be an input or an output.
11	8	S9	Source Terminal 9. This pin can be an input or an output.
12	9	GND	Ground (0 V) Reference.
14	10	A3	Logic Control Input.
15	11	A2	Logic Control Input.
16	14	A1	Logic Control Input.
17	15	A0	Logic Control Input.
18	16	EN	Active High Digital Input. When this pin is low, the device is disabled and all switches are turned off. When this pin is high, the Ax logic inputs determine which switch is turned on.
19	17	S1	Source Terminal 1. This pin can be an input or an output.
20	18	S2	Source Terminal 2. This pin can be an input or an output.
21	19	S3	Source Terminal 3. This pin can be an input or an output.
22	20	S4	Source Terminal 4. This pin can be an input or an output.
23	21	S5	Source Terminal 5. This pin can be an input or an output.
24	22	S6	Source Terminal 6. This pin can be an input or an output.
25	23	S7	Source Terminal 7. This pin can be an input or an output.
26	24	S8	Source Terminal 8. This pin can be an input or an output.
27	25	V _{SS}	Most Negative Power Supply Potential. In single-supply applications, this pin can be connected to ground.
28	29	D	Drain Terminal. This pin can be an input or an output.
NA	Exposed Pad		The exposed pad is connected internally. For increased reliability of the solder joints and maximum thermal capability, it is recommended that the pad be soldered to the substrate, V _{SS} .

Table 9. ADG5206 Truth Table

A3	A2	A1	A0	EN	On Switch
X	X	X	X	0	None
0	0	0	0	1	1
0	0	0	1	1	2
0	0	1	0	1	3
0	0	1	1	1	4
0	1	0	0	1	5
0	1	0	1	1	6
0	1	1	0	1	7
0	1	1	1	1	8
1	0	0	0	1	9
1	0	0	1	1	10
1	0	1	0	1	11
1	0	1	1	1	12
1	1	0	0	1	13
1	1	0	1	1	14
1	1	1	0	1	15
1	1	1	1	1	16

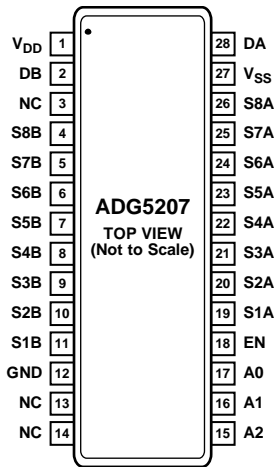

NOTES
1. NO CONNECT. NOT INTERNALLY CONNECTED.

Figure 5. ADG5207 Pin Configuration (TSSOP)

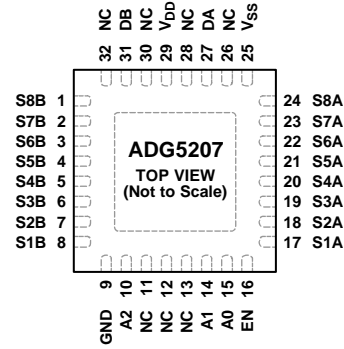

NOTES
1. NO CONNECT. NOT INTERNALLY CONNECTED.
2. THE EXPOSED PAD IS CONNECTED INTERNALLY. FOR INCREASED RELIABILITY OF THE SOLDER JOINTS AND MAXIMUM THERMAL CAPABILITY, IT IS RECOMMENDED THAT THE PAD BE SOLDERED TO THE SUBSTRATE, V_{SS}.

Figure 6. ADG5207 Pin Configuration (LFCSP)

Table 10. ADG5207 Pin Function Descriptions

Pin No.		Mnemonic	Description
TSSOP	LFCSP		
1	29	V _{DD}	Most Positive Power Supply Potential.
2	31	DB	Drain Terminal B. This pin can be an input or an output.
3, 13, 14	11, 12, 12, 26, 28, 30, 32	NC	No Connect. Not internally connected.
4	1	S8B	Source Terminal 8B. This pin can be an input or an output.
5	2	S7B	Source Terminal 7B. This pin can be an input or an output.
6	3	S6B	Source Terminal 6B. This pin can be an input or an output.
7	4	S5B	Source Terminal 5B. This pin can be an input or an output.
8	5	S4B	Source Terminal 4B. This pin can be an input or an output.
9	6	S3B	Source Terminal 3B. This pin can be an input or an output.
10	7	S2B	Source Terminal 2B. This pin can be an input or an output.
11	8	S1B	Source Terminal 1B. This pin can be an input or an output.
12	9	GND	Ground (0 V) Reference.
15	10	A2	Logic Control Input.
16	14	A1	Logic Control Input.
17	15	A0	Logic Control Input.
18	16	EN	Active High Digital Input. When this pin is low, the device is disabled and all switches are turned off. When this pin is high, the Ax logic inputs determine which switch is turned on.
19	17	S1A	Source Terminal 1A. This pin can be an input or an output.
20	18	S2A	Source Terminal 2A. This pin can be an input or an output.
21	19	S3A	Source Terminal 3A. This pin can be an input or an output.
22	20	S4A	Source Terminal 4A. This pin can be an input or an output.
23	21	S5A	Source Terminal 5A. This pin can be an input or an output.
24	22	S6A	Source Terminal 6A. This pin can be an input or an output.
25	23	S7A	Source Terminal 7A. This pin can be an input or an output.
26	24	S8A	Source Terminal 8A. This pin can be an input or an output.
27	25	V _{SS}	Most Negative Power Supply Potential. In single-supply applications, this pin can be connected to ground.
28	27	DA	Drain Terminal A. This pin can be an input or an output.
NA	Exposed Pad		The exposed pad is connected internally. For increased reliability of the solder joints and maximum thermal capability, it is recommended that the pad be soldered to the substrate, V _{SS} .

Table 11. ADG5207 Truth Table

A2	A1	A0	EN	On Switch Pair
X	X	X	0	None
0	0	0	1	1
0	0	1	1	2
0	1	0	1	3
0	1	1	1	4
1	0	0	1	5
1	0	1	1	6
1	1	0	1	7
1	1	1	1	8

TYPICAL PERFORMANCE CHARACTERISTICS

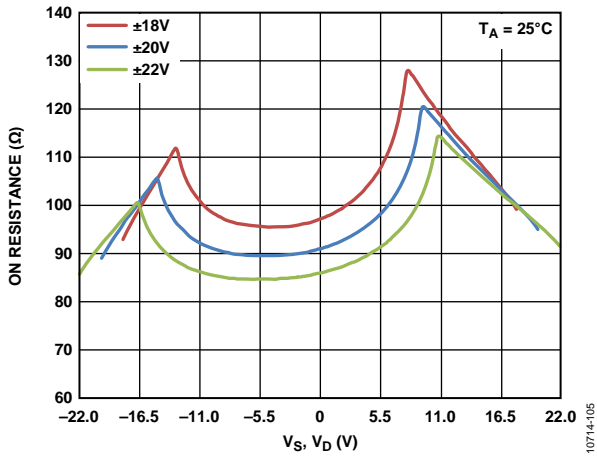

Figure 7. R_{ON} as a Function of V_S, V_D (± 20 V Dual Supply)

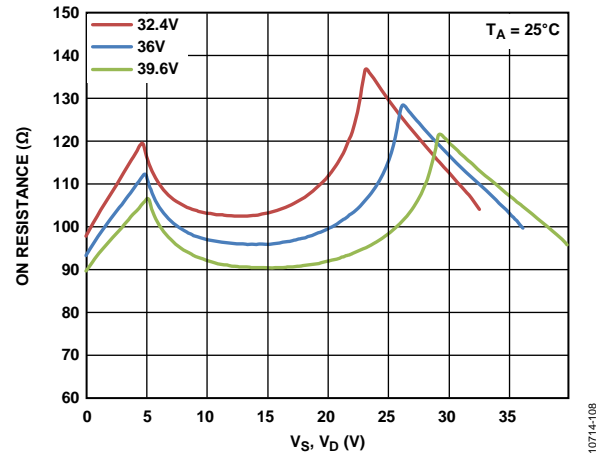

Figure 10. R_{ON} as a Function of V_S, V_D (36 V Single Supply)

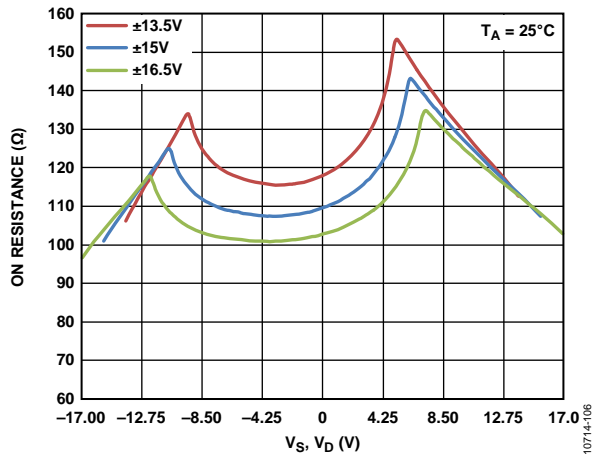

Figure 8. R_{ON} as a Function of V_S, V_D (± 15 V Dual Supply)

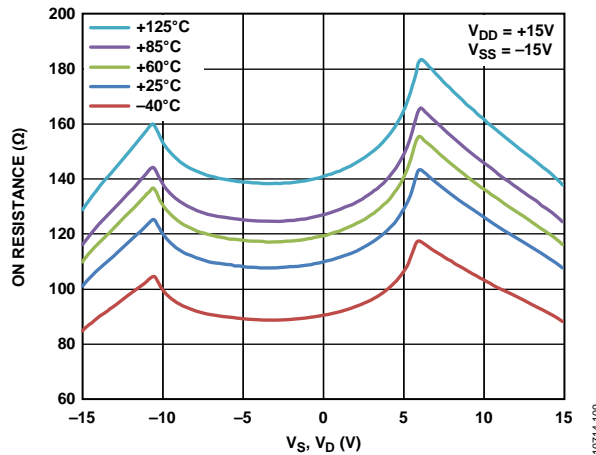

Figure 11. R_{ON} as a Function of V_S, V_D for Different Temperatures, ± 15 V Dual Supply

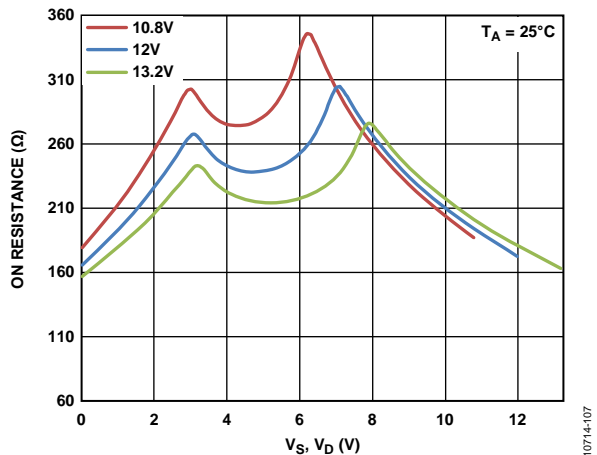

Figure 9. R_{ON} as a Function of V_S, V_D (12 V Single Supply)

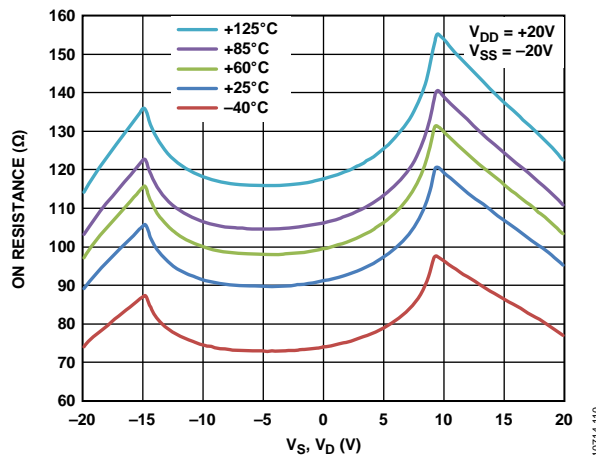

Figure 12. R_{ON} as a Function of V_S, V_D for Different Temperatures, ± 20 V Dual Supply

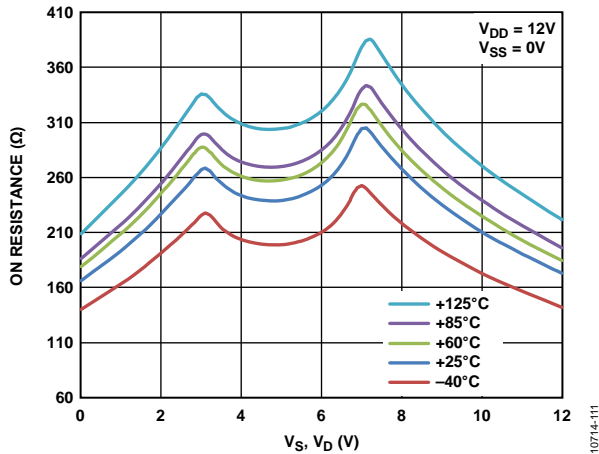

Figure 13. R_{ON} as a Function of V_S , V_D for Different Temperatures, 12 V Single Supply

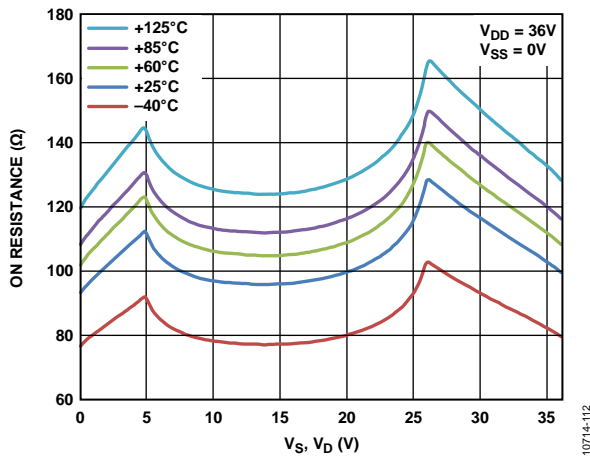

Figure 14. R_{ON} as a Function of V_S , V_D for Different Temperatures, 36 V Single Supply

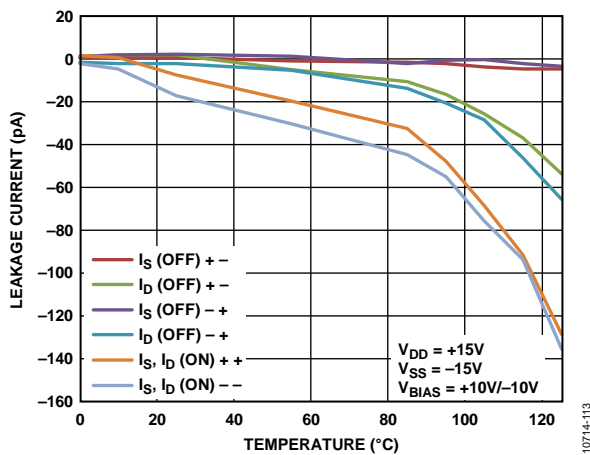

Figure 15. Leakage Currents vs. Temperature, ±15 V Dual Supply

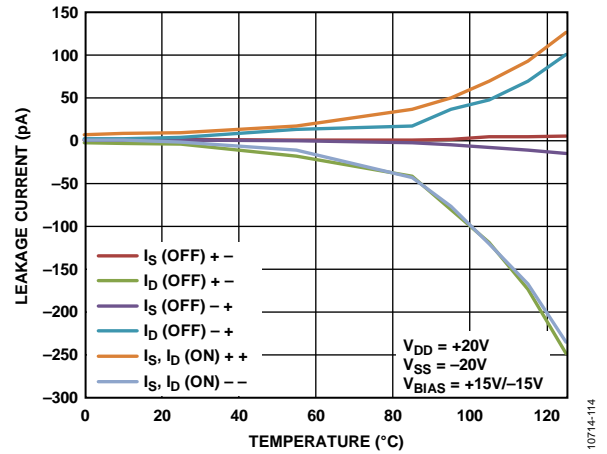

Figure 16. Leakage Currents vs. Temperature, ±20 V Dual Supply

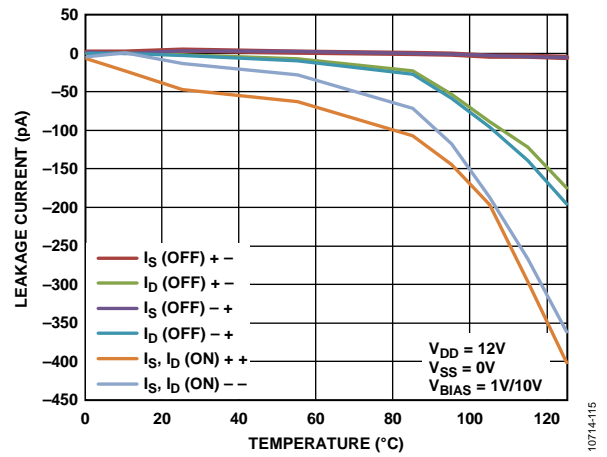

Figure 17. Leakage Currents vs. Temperature, 12 V Single Supply

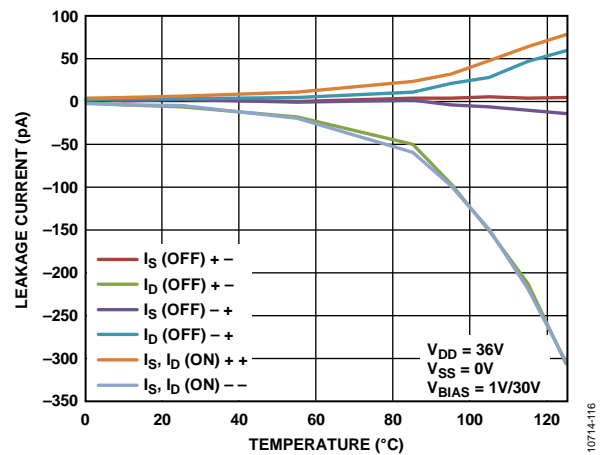

Figure 18. Leakage Currents vs. Temperature, 36 V Single Supply

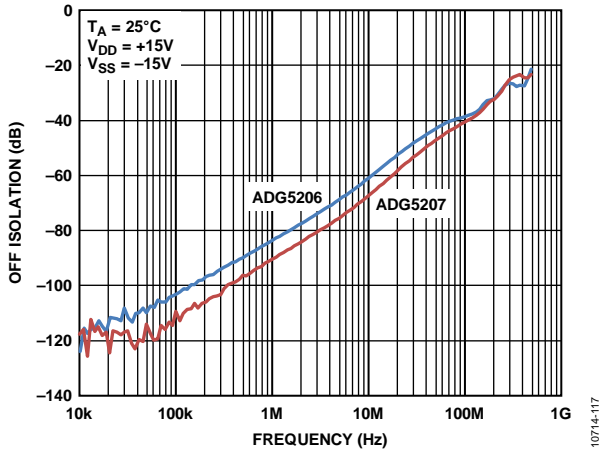

Figure 19. Off Isolation vs. Frequency, ±15 V Dual Supply

10714-117

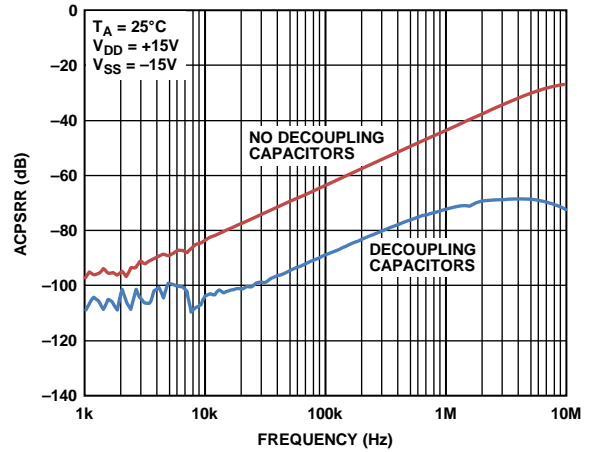

Figure 22. ACPSRR vs. Frequency, ±15 V Dual Supply

10714-120

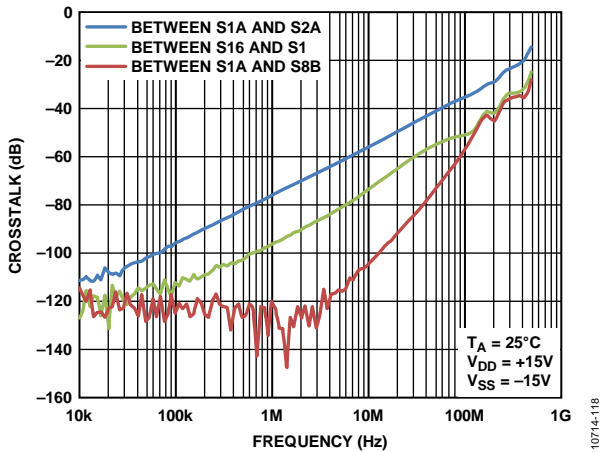

Figure 20. Crosstalk vs. Frequency, ±15 V Dual Supply

10714-118

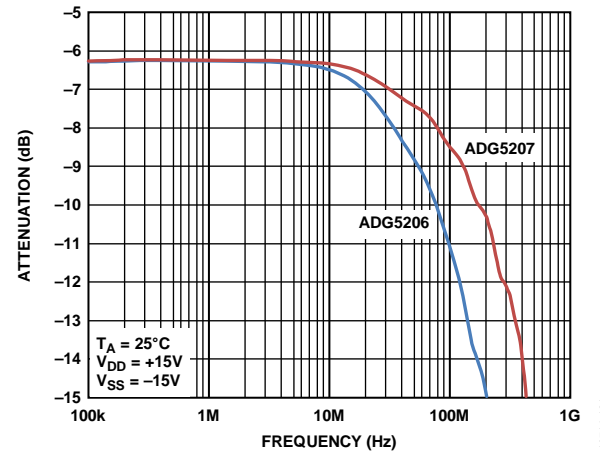

Figure 23. Bandwidth

10714-121

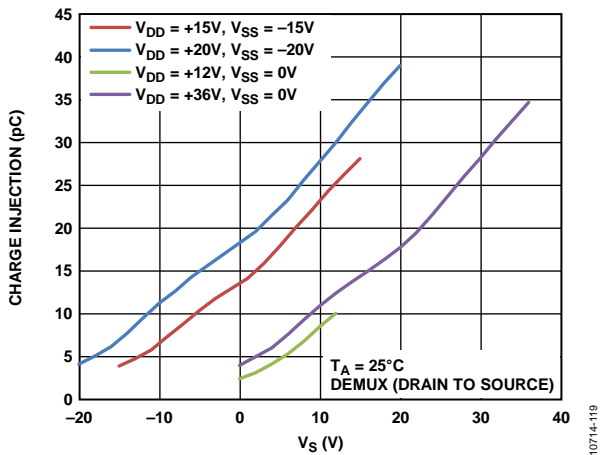

Figure 21. Charge Injection vs. Source Voltage, Drain to Source

10714-119

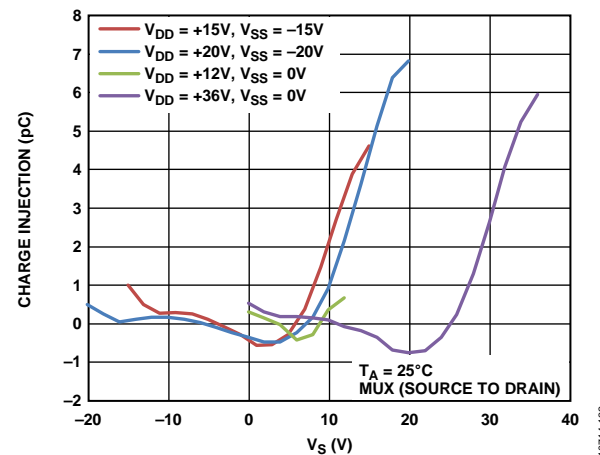

Figure 24. Charge Injection vs. Source Voltage, Source to Drain

10714-122

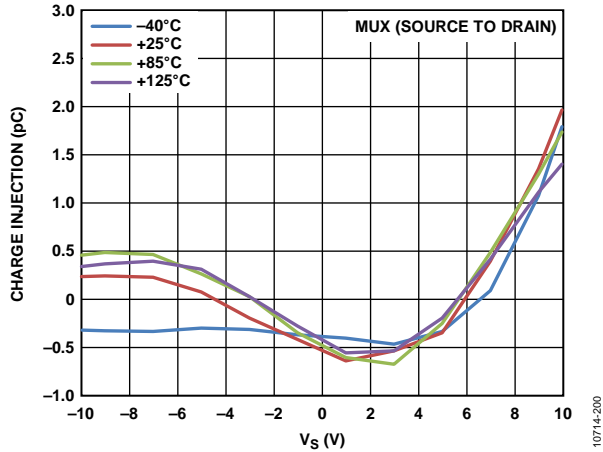

Figure 25. Q_{INJ} as a Function of V_S for Different Temperatures, ± 15 V Dual Supply

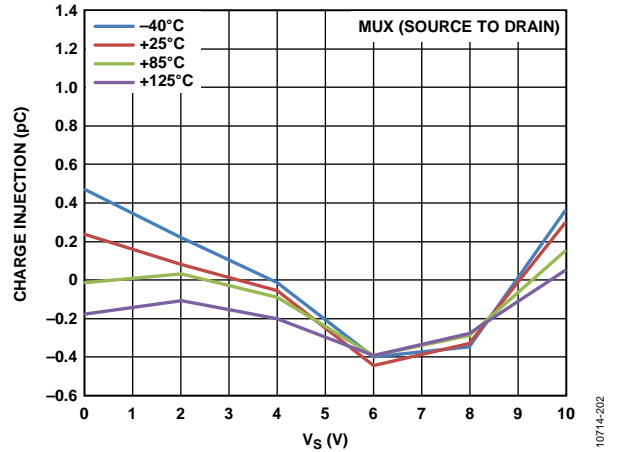

Figure 28. Q_{INJ} as a Function of V_S for Different Temperatures, 12 V Single Supply

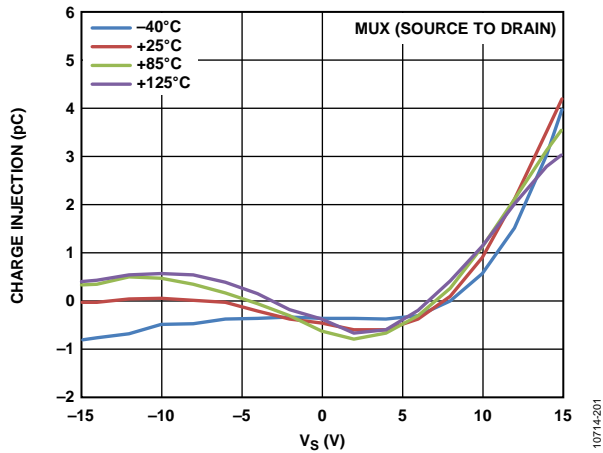

Figure 26. Q_{INJ} as a Function of V_S for Different Temperatures, ± 20 V Dual Supply

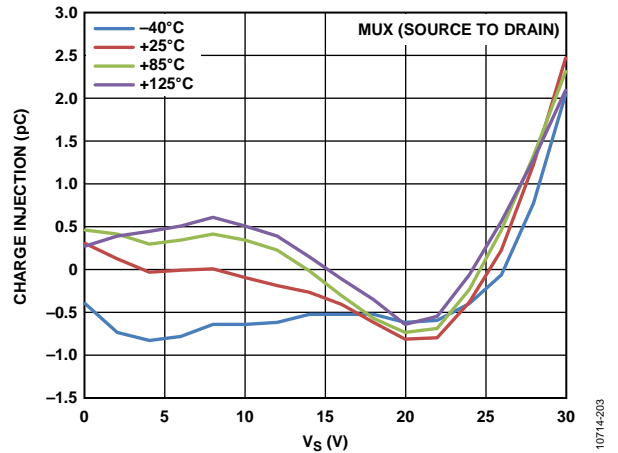

Figure 29. Q_{INJ} as a Function of V_S for Different Temperatures, 36 V Single Supply

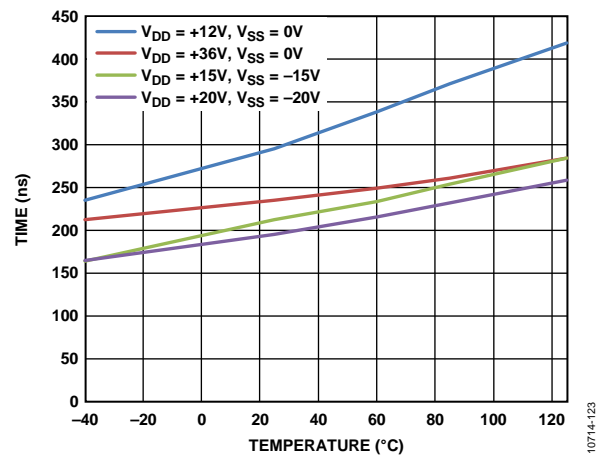

Figure 27. $t_{TRANSITION}$ Time vs. Temperature

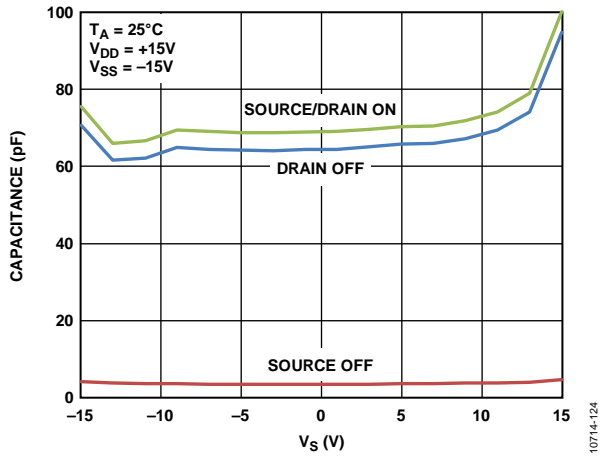

Figure 30. ADG5206 Capacitance vs. Source Voltage, $\pm 15\text{ V}$ Dual Supply

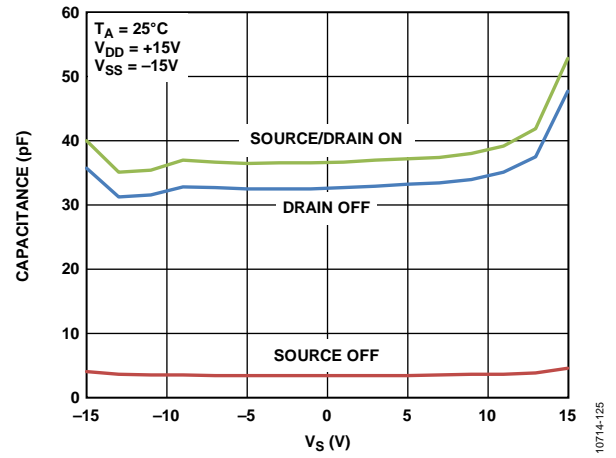

Figure 31. ADG5207 Capacitance vs. Source Voltage, $\pm 15\text{ V}$ Dual Supply

TEST CIRCUITS

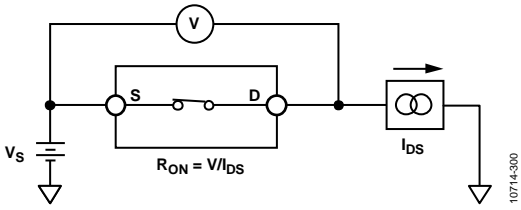

Figure 32. On Resistance

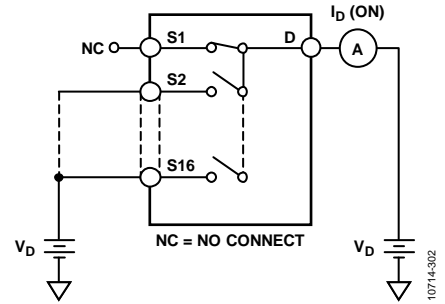

Figure 34. On Leakage

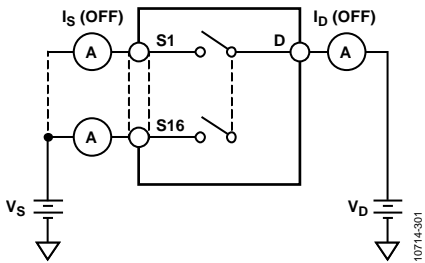
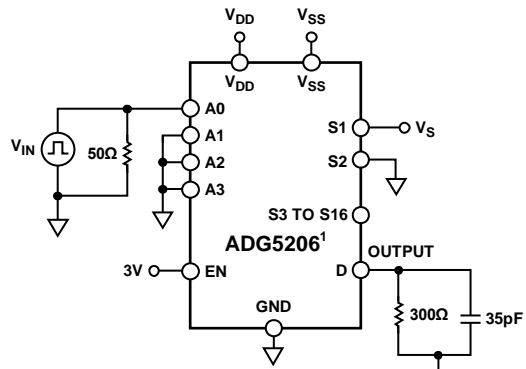
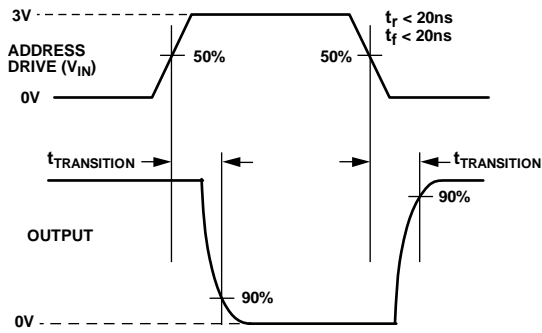
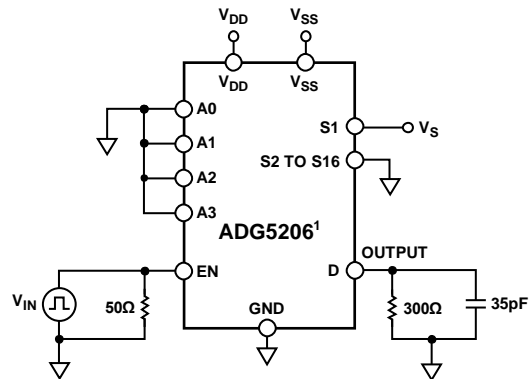
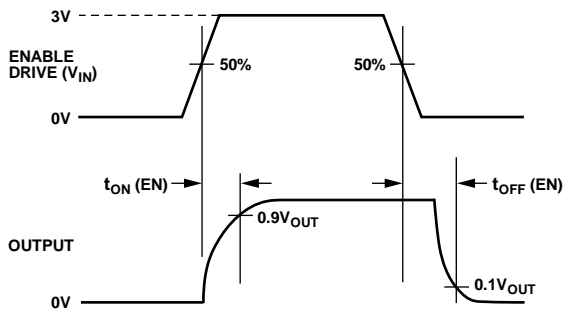

Figure 33. Off Leakage



¹SIMILAR CONNECTION FOR ADG5207.

Figure 35. Address to Output Switching Times, $t_{\text{TRANSITION}}$



¹SIMILAR CONNECTION FOR ADG5207.

Figure 36. Enable Delay, $t_{\text{ON}}(\text{EN})$, $t_{\text{OFF}}(\text{EN})$

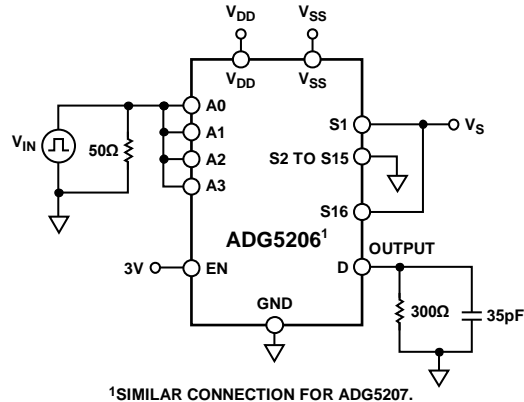
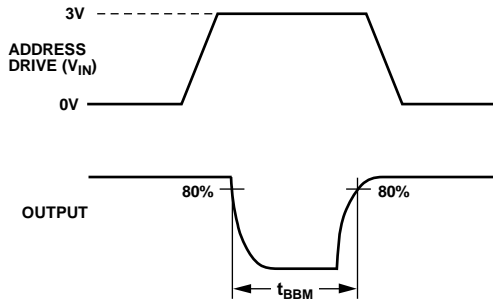

10714-036

Figure 37. Break-Before-Make Time Delay, t_D

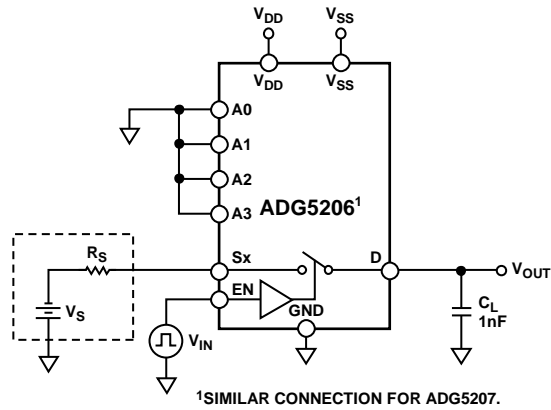
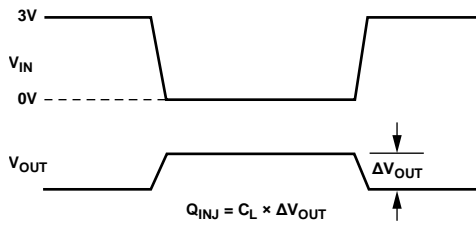

10714-037

Figure 38. Charge Injection

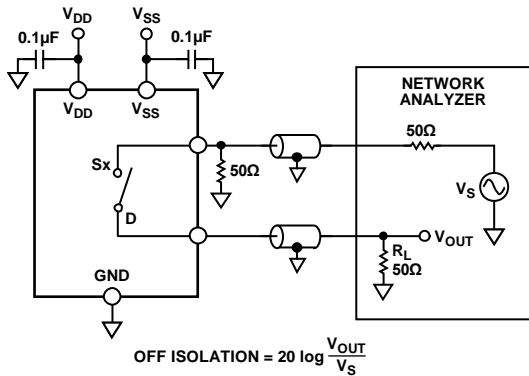

10714-032

Figure 39. Off Isolation

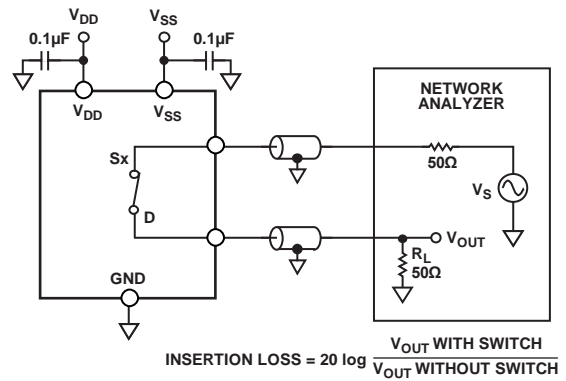

10714-033

Figure 41. Bandwidth

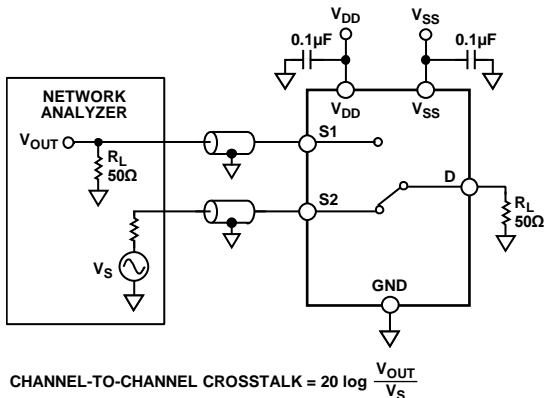

10714-030

Figure 40. Channel-to-Channel Crosstalk

TERMINOLOGY

I_{DD}

I_{DD} represents the positive supply current.

I_{SS}

I_{SS} represents the negative supply current.

V_D, V_S

V_D and V_S represent the analog voltage on Terminal D and Terminal S, respectively.

R_{ON}

R_{ON} is the ohmic resistance between Terminal D and Terminal S.

ΔR_{ON}

ΔR_{ON} represents the difference between the R_{ON} of any two channels.

$R_{FLAT(ON)}$

$R_{FLAT(ON)}$ is the flatness defined as the difference between the maximum and the minimum value of on resistance measured over the specified analog signal range.

I_S (Off)

I_S (Off) is the source leakage current with the switch off.

I_D (Off)

I_D (Off) is the drain leakage current with the switch off.

I_D (On), I_S (On)

I_D (On) and I_S (On) represent the channel leakage currents with the switch on.

V_{INL}

V_{INL} is the maximum input voltage for Logic 0.

V_{INH}

V_{INH} is the minimum input voltage for Logic 1.

I_{INL}, I_{INH}

I_{INL} and I_{INH} represent the low and high input currents of the digital inputs.

C_D (Off)

C_D (Off) represents the off switch drain capacitance, which is measured with reference to ground.

C_S (Off)

C_S (Off) represents the off switch source capacitance, which is measured with reference to ground.

C_D (On), C_S (On)

C_D (On) and C_S (On) represent on switch capacitances, which are measured with reference to ground.

C_{IN}

C_{IN} represents digital input capacitance.

$t_{ON(EN)}$

$t_{ON(EN)}$ represents the delay time between the 50% and 90% points of the digital input and switch on condition.

$t_{OFF(EN)}$

$t_{OFF(EN)}$ represents the delay time between the 50% and 90% points of the digital input and switch off condition.

$t_{TRANSITION}$

$t_{TRANSITION}$ represents the delay time between the 50% and 90% points of the digital inputs and the switch on condition when switching from one address state to another.

Break-Before-Make Time Delay (t_D)

t_D represents the off time measured between the 80% point of both switches when switching from one address state to another.

Off Isolation

Off isolation is a measure of unwanted signal coupling through an off channel.

Charge Injection

Charge injection is a measure of the glitch impulse transferred from the digital input to the analog output during switching.

Crosstalk

Crosstalk is a measure of unwanted signal that is coupled through from one channel to another as a result of parasitic capacitance.

Bandwidth

Bandwidth is the frequency at which the output is attenuated by 3 dB.

On Response

On response is the frequency response of the on switch.

AC Power Supply Rejection Ratio (ACPSRR)

ACPSRR is a measure of the ability of a device to avoid coupling noise and spurious signals that appear on the supply voltage pin to the output of the switch. The dc voltage on the device is modulated by a sine wave of 0.62 V p-p. The ratio of the amplitude of signal on the output to the amplitude of the modulation is the ACPSRR.

APPLICATIONS INFORMATION

The ADG52xx family of switches and multiplexers provides a robust solution for instrumentation, industrial, automotive, aerospace, and other harsh environments that are prone to latch-up, which is an undesirable high current state that can lead to device failure and persist until the power supply is turned off. The ADG5206/ADG5207 high voltage switches allow single-supply operation from 9 V to 40 V and dual-supply operation from ± 9 V to ± 22 V.

TRENCH ISOLATION

In the ADG5206/ADG5207, an insulating oxide layer (trench) is placed between the NMOS and the PMOS transistors of each CMOS switch. Parasitic junctions, which occur between the transistors in junction isolated switches, are eliminated, and the result is a completely latch-up proof switch.

In junction isolation, the N and P wells of the PMOS and NMOS transistors form a diode that is reverse-biased under normal operation. However, during overvoltage conditions, this diode can become forward-biased. A silicon controlled rectifier (SCR) type circuit is formed by the two transistors, causing a significant amplification of the current that, in turn, leads to latch-up. With trench isolation, this diode is removed and the result is a latch-up proof switch.

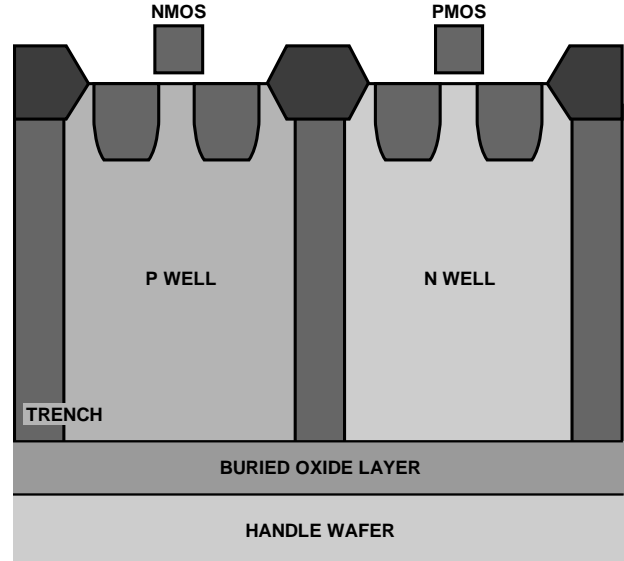
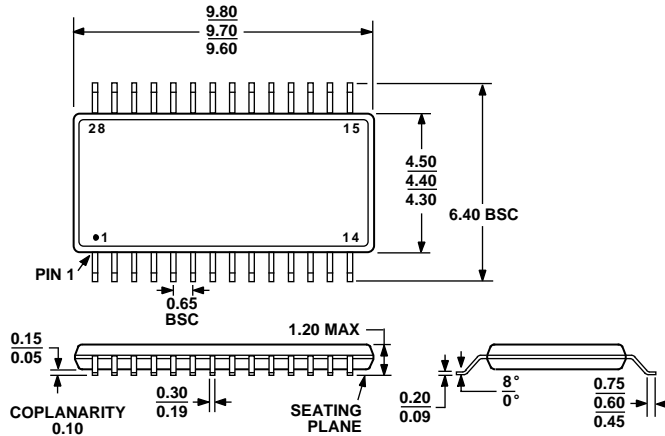

Figure 42. Trench Isolation

10714-038

OUTLINE DIMENSIONS



COMPLIANT TO JEDEC STANDARDS MO-153-AE

Figure 43. 28-Lead Thin Shrink Small Outline Package [TSSOP] (RU-28)

Dimensions shown in millimeters

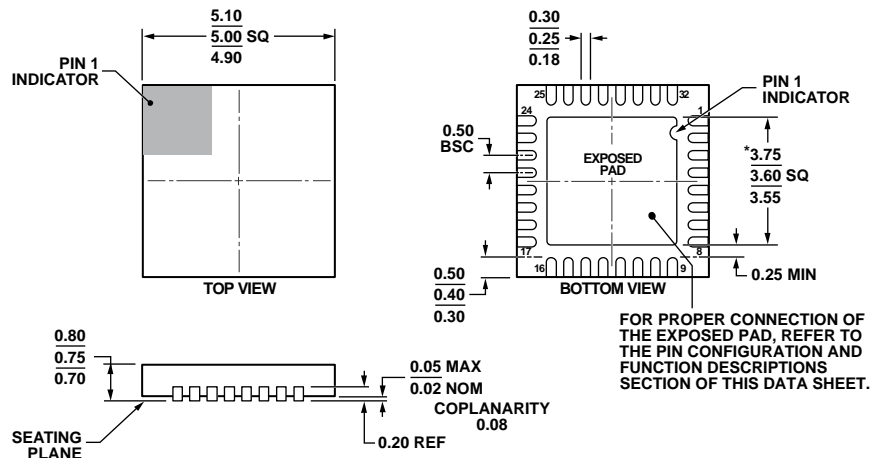

*COMPLIANT TO JEDEC STANDARDS MO-220-WHHD-5 WITH EXCEPTION TO EXPOSED PAD DIMENSION.

Figure 44. 32-Lead Lead Frame Chip Scale Package [LFCSP_WQ]

5 x 5 mm Body, Very Very Thin Quad (CP-32-12)

Dimensions shown in millimeters

08-16-2010-B

ORDERING GUIDE

Model ¹	Temperature Range	Package Description	Package Option
ADG5206BRUZ	-40°C to +125°C	28-Lead Thin Shrink Small Outline Package [TSSOP]	RU-28
ADG5206BRUZ-RL7	-40°C to +125°C	28-Lead Thin Shrink Small Outline Package [TSSOP]	RU-28
ADG5206BCPZ-RL7	-40°C to +125°C	32-Lead Lead Frame Chip Scale Package [LFCSP_WQ]	CP-32-12
ADG5207BRUZ	-40°C to +125°C	28-Lead Thin Shrink Small Outline Package [TSSOP]	RU-28
ADG5207BRUZ-RL7	-40°C to +125°C	28-Lead Thin Shrink Small Outline Package [TSSOP]	RU-28
ADG5207BCPZ-RL7	-40°C to +125°C	32-Lead Lead Frame Chip Scale Package [LFCSP_WQ]	CP-32-12

¹ Z = RoHS Compliant Part.

NOTES

NOTES

NOTES

Looking for pricing, stock, or lifecycle information?

Click below to explore more details on WIN SOURCE:

 [View ADG5207BCPZ-RL7 on WIN SOURCE](#)

 [Analog Devices Inc. Information](#)

Optimize Your Supply Chain with WIN SOURCE Solutions

-  Global Sourcing Solution
-  Obsolete Management
-  Cost Control Management
-  Shortage Management
-  Alternative Solution
-  Excess Inventory Management