



**THE DATASHEET OF  
ADR370ARTZ-REEL7**



### FEATURES

**Initial accuracy:  $\pm 4$  mV maximum**

**Initial accuracy error:  $\pm 0.2\%$**

**Low TCVO**

**$\pm 50$  ppm/ $^{\circ}\text{C}$  maximum from  $-40^{\circ}\text{C}$  to  $+125^{\circ}\text{C}$**

**$30$  ppm/ $^{\circ}\text{C}$  maximum from  $+25^{\circ}\text{C}$  to  $+70^{\circ}\text{C}$**

**Load regulation:  $400$   $\mu\text{V}/\text{mA}$ ,  $100$  ppm/ $\text{mA}$**

**Line regulation:  $25$   $\mu\text{V}/\text{V}$ ,  $20$  ppm/ $\text{V}$**

**Wide operating range:  $V_{\text{IN}} = 2.3$  V to  $15$  V**

**Low power:  $72$   $\mu\text{A}$  maximum**

**High output sink/source current:  $\pm 5$  mA minimum**

**Wide temperature range:  $-40^{\circ}\text{C}$  to  $+125^{\circ}\text{C}$**

**Tiny 3-lead SOT-23 package with standard pin configuration**

### APPLICATIONS

**Battery-powered instrumentation**

**Portable medical instruments**

**Data acquisition systems**

**Industrial process control systems**

**Automotive**

### GENERAL DESCRIPTION

The ADR370<sup>1</sup> is a low cost, 3-terminal (series) band gap voltage reference featuring high accuracy, high stability, and low power consumption packaged in a tiny 3-lead SOT-23 package. Precise matching and thermal tracking of on-chip components, as well as patented temperature drift curvature correction design techniques, have been employed to ensure that the ADR370 provides an accurate 2.048 V output.

### PIN CONFIGURATION

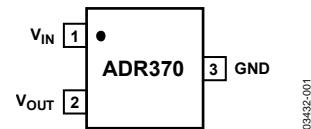

Figure 1. 3-Lead SOT-23

Table 1. ADR370 Products

Products	Output Voltage (V)	Initial Accuracy $\pm$		Temperature Coefficient (ppm/ $^{\circ}\text{C}$ )
		(mV)	(%)	
ADR370BRT-REEL7	2.048	4	0.2	50
ADR370ART-REEL7	2.048	10	0.5	100

This micropowered, low dropout voltage device sources or sinks up to 5 mA of load current while providing a stable 2.048 V output. The compact footprint, high accuracy, and operating range of 2.3 V to 15 V make the ADR370 ideal for use in 3 V and 5 V systems where there can be wide variations in supply voltage and a need to minimize power dissipation.

The ADR370 is offered in A and B grades; all devices are specified over the extended industrial range of  $-40^{\circ}\text{C}$  to  $+125^{\circ}\text{C}$ .

<sup>1</sup> Protected by U.S. Patent No. 5,969,657; other patents pending.

#### Rev. C

Information furnished by Analog Devices is believed to be accurate and reliable. However, no responsibility is assumed by Analog Devices for its use, nor for any infringements of patents or other rights of third parties that may result from its use. Specifications subject to change without notice. No license is granted by implication or otherwise under any patent or patent rights of Analog Devices. Trademarks and registered trademarks are the property of their respective owners.

## TABLE OF CONTENTS

Features .....	1	Theory of Operation .....	8
Applications.....	1	Applying the ADR370.....	8
Pin Configuration.....	1	Applications Information .....	9
General Description .....	1	Low Cost Negative Reference .....	9
Revision History .....	2	Precision Negative Reference.....	9
Specifications.....	3	Low Cost Current Source.....	9
Electrical Characteristics .....	3	Precision Current Source with Adjustable Output .....	9
Absolute Maximum Ratings.....	4	12-Bit Precision Programmable Current Source .....	10
Thermal Resistance .....	4	Precision Boosted Output Regulator .....	10
ESD Caution.....	4	Outline Dimensions .....	11
Typical Performance Characteristics .....	5	Ordering Guide .....	11
Terminology .....	7		

## REVISION HISTORY

### 12/07—Rev. B to Rev. C

Changes to Line Regulation Specification.....	3
---	---

### 9/07—Rev. A to Rev. B

Updated Format.....	Universal
Changes to Table 2.....	3
Changes to Ordering Guide .....	11
Updated Outline Dimensions .....	11

### 7/03—Rev. 0 to Rev. A

Changes to Features.....	1
Changes to Table I .....	1
Changes to Electrical Characteristics .....	2
Changes to Absolute Maximum Ratings .....	3
Changes to Ordering Guide .....	3
Changes to Parameter Definitions .....	6
Updated Outline Dimensions .....	9

## SPECIFICATIONS

### ELECTRICAL CHARACTERISTICS

$T_A = T_{MIN}$  to  $T_{MAX}$ ,  $V_{IN} = 5$  V, unless otherwise noted.

Table 2.

Parameter	Symbol	Conditions	Min	Typ	Max	Unit
OUTPUT VOLTAGE (@ 25°C)	$V_O$		2.044	2.048	2.052	V
INITIAL ACCURACY ERROR	$V_{OERR}$					
A Grade			-10		+10	mV
B Grade			-0.5		+0.5	%
			-4		+4	mV
			-0.2		+0.2	%
OUTPUT VOLTAGE TEMPERATURE DRIFT <sup>1</sup>	$TCV_O$					
A Grade		$T_A = -40^\circ\text{C}$ to $+125^\circ\text{C}$			100	ppm/°C
B Grade		$T_A = -40^\circ\text{C}$ to $+125^\circ\text{C}$			50	ppm/°C
		$T_A = 25^\circ\text{C}$ to $70^\circ\text{C}$			30	ppm/°C
SUPPLY HEADROOM	$V_{IN} - V_{OUT}$		200			mV
LOAD REGULATION		$0\text{ mA} < I_{OUT} < 5\text{ mA}$ @ $25^\circ\text{C}$ $-3\text{ mA} < I_{OUT} < 0\text{ mA}$ @ $25^\circ\text{C}$ $-0.1\text{ mA} < I_{OUT} < +0.1\text{ mA}$			+0.400 +0.600 +4.75	mV/mA mV/mA mV/mA
LINE REGULATION		$V_{OUT} + 200\text{ mV} < V_{IN} < 15\text{ V}$ $I_{OUT} = 0\text{ mA}$			20	ppm/V
RIPPLE REJECTION	$\Delta V_{OUT}/\Delta V_{IN}$	$V_{IN} = 5\text{ V} \pm 100\text{ mV}$ ( $f = 120\text{ Hz}$ )	80			dB
QUIESCENT CURRENT					72	$\mu\text{A}$
SHORT-CIRCUIT CURRENT TO GROUND					15	mA
NOISE VOLTAGE (@ 25°C)		0.1 Hz to 10 Hz 10 Hz to 10 kHz		70 50		$\mu\text{V p-p}$ $\mu\text{V rms}$
TURN-ON SETTLING TIME	$C_L = 0.2\ \mu\text{F}$			100		$\mu\text{s}$
LONG-TERM STABILITY		1000 hours @ $25^\circ\text{C}$			100	ppm/1000 hrs
OUTPUT VOLTAGE HYSTERESIS				115		ppm
TEMPERATURE RANGE			-40		+125	°C

<sup>1</sup> Guaranteed by characterization.

# ADR370

## ABSOLUTE MAXIMUM RATINGS

Ratings at 25°C, unless otherwise noted.

Table 3.

Parameter	Rating
Supply Voltage	18 V
Storage Temperature Range	−65°C to +125°C
Operating Temperature Range	−40°C to +125°C
Lead Temperature	
Soldering, 60 sec	215°C
Infrared, 15 sec	220°C

Stresses above those listed under Absolute Maximum Ratings may cause permanent damage to the device. This is a stress rating only; functional operation of the device at these or any other conditions above those indicated in the operational section of this specification is not implied. Exposure to absolute maximum rating conditions for extended periods may affect device reliability.

## THERMAL RESISTANCE

$\theta_{JA}$  is specified for the worst-case conditions, that is, a device soldered in a circuit board for surface-mount packages.

Table 4.

Package Type	$\theta_{JA}$	$\theta_{JC}$	Unit
3-Lead SOT-23 (RT)	220	102	°C/W

## ESD CAUTION



**ESD (electrostatic discharge) sensitive device.** Charged devices and circuit boards can discharge without detection. Although this product features patented or proprietary protection circuitry, damage may occur on devices subjected to high energy ESD. Therefore, proper ESD precautions should be taken to avoid performance degradation or loss of functionality.

# TYPICAL PERFORMANCE CHARACTERISTICS

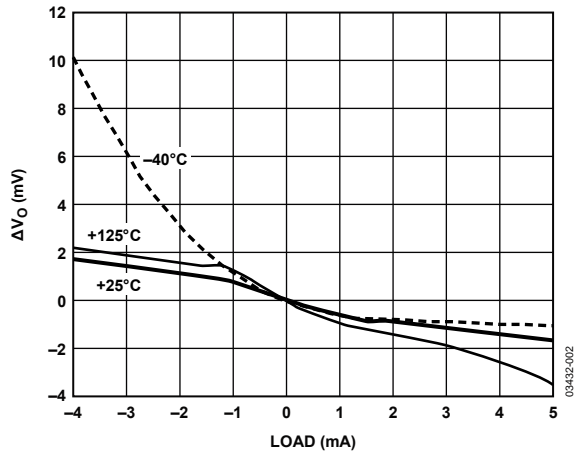

Figure 2. Load Regulation vs. Load Current

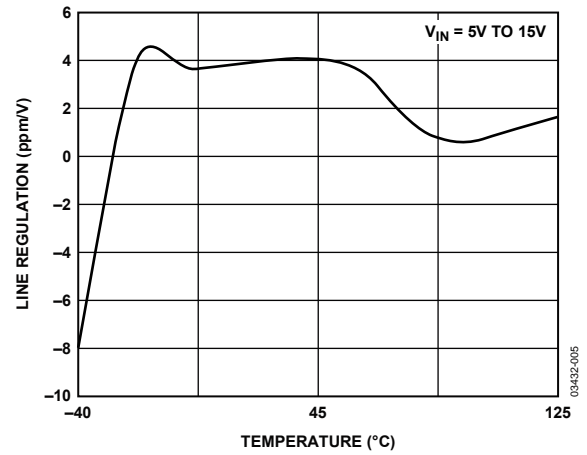

Figure 5. Line Regulation vs. Temperature

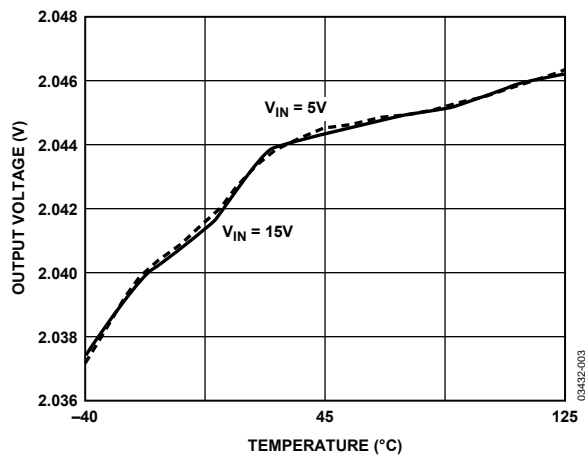

Figure 3. Output Voltage vs. Temperature

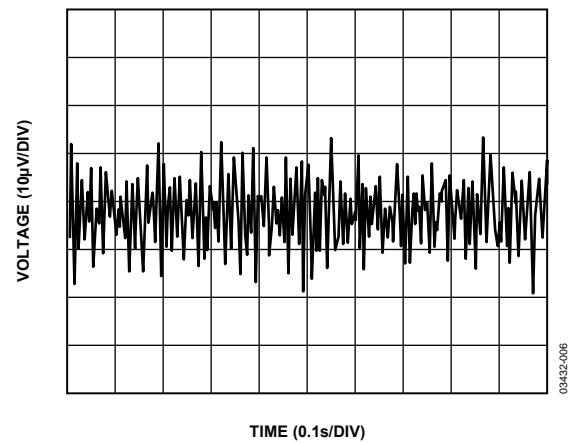

Figure 6. Voltage Noise 0.1 Hz to 10 Hz

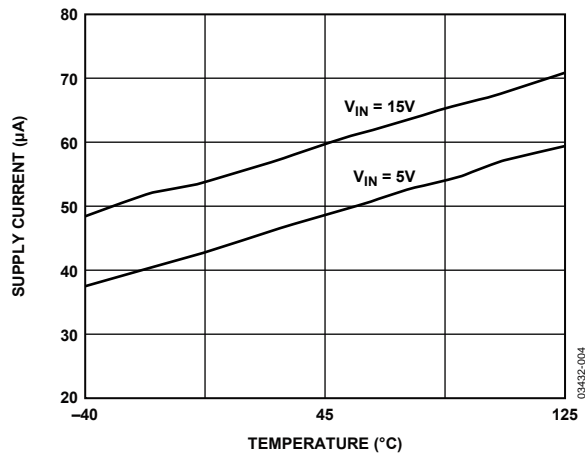

Figure 4. Supply Current vs. Temperature

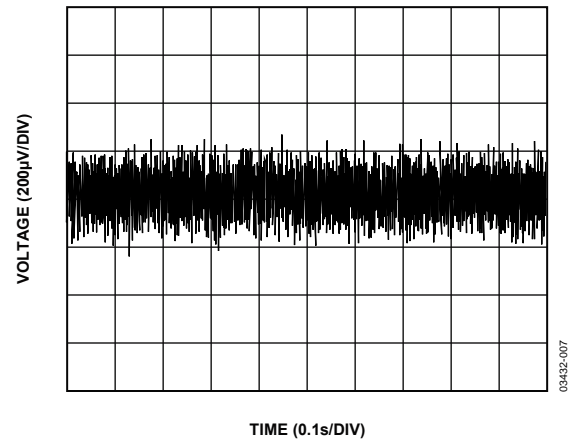

Figure 7. Voltage Noise 10 Hz to 100 kHz

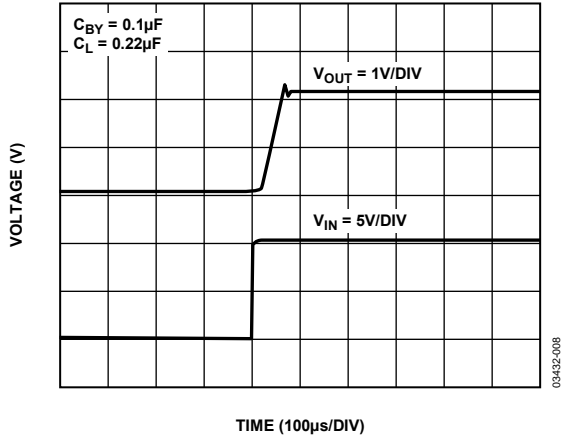

Figure 8. Turn-On Response

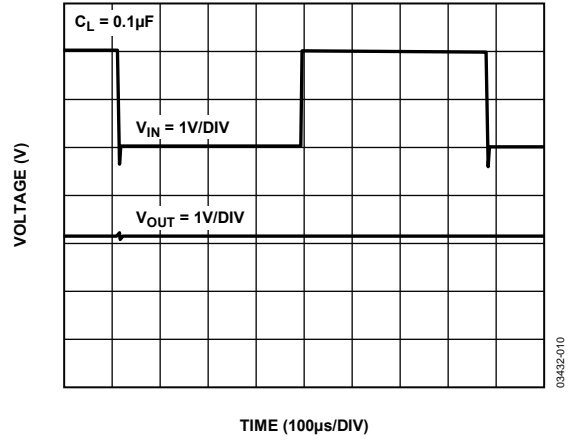

Figure 10. Line Transient Response

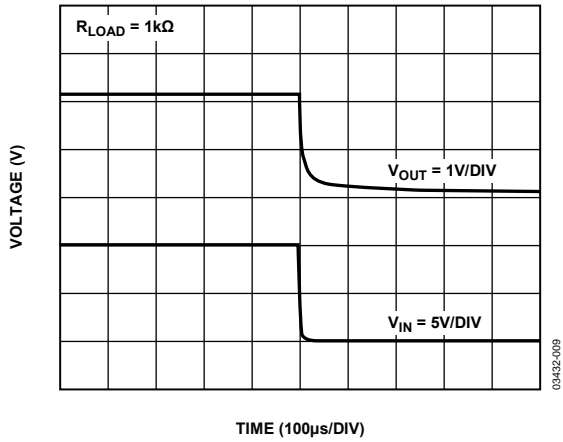

Figure 9. Turn-Off Response

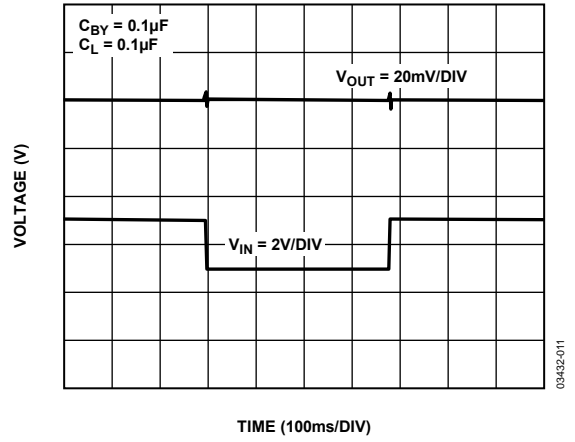

Figure 11. Load Transient Response

## TERMINOLOGY

### Temperature Coefficient

Temperature coefficient is the change of output voltage with respect to operating temperature changes, normalized by the output voltage at 25°C. This parameter is expressed in ppm/°C and can be determined by the following equation:

$$TCV_o \left[ \frac{\text{ppm}}{^\circ\text{C}} \right] = \frac{V_o(T_2) - V_o(T_1)}{V_o(25^\circ\text{C}) \times (T_2 - T_1)} \times 10^6 \quad (1)$$

where:

$V_o(25^\circ\text{C}) = V_o$  at 25°C.

$V_o(T_1) = V_o$  at Temperature 1.

$V_o(T_2) = V_o$  at Temperature 2.

### Line Regulation

Line regulation is the change in output voltage due to a specified change in input voltage. This parameter accounts for the effects of self-heating. Line regulation is expressed in either percent per volt, parts-per-million per volt, or microvolts per volt change in input voltage.

### Load Regulation

Load regulation is the change in output voltage due to a specified change in load current. This parameter accounts for the effects of self-heating. Load regulation is expressed in either microvolts per milliampere, parts-per-million per milliampere, or ohms of dc output resistance.

### Long-Term Stability

Long-term stability is the typical shift of output voltage at 25°C on a sample of parts subjected to a test of 1000 hours at 25°C.

$$\begin{aligned} \Delta V_o &= V_o(t_1) - V_o(t_2) \\ \Delta V_o [\text{ppm}] &= \frac{V_o(t_1) - V_o(t_2)}{V_o(t_1)} \times 10^6 \end{aligned} \quad (2)$$

where:

$V_o(t_1) = V_o$  at 25°C at Time 0.

$V_o(t_2) = V_o$  at 25°C after 1000 hours operation at 25°C.

### Thermal Hysteresis

Thermal hysteresis is defined as the change of output voltage after the device is cycled through temperature from +25°C to -40°C to +125°C and back to +25°C. This is a typical value from a sample of parts put through such a cycle.

$$\begin{aligned} V_{O\_HYS} &= V_o(25^\circ\text{C}) - V_{O\_TC} \\ V_{O\_HYS} [\text{ppm}] &= \frac{V_o(25^\circ\text{C}) - V_{O\_TC}}{V_o(25^\circ\text{C})} \times 10^6 \end{aligned} \quad (3)$$

where:

$V_o(25^\circ\text{C}) = V_o$  at 25°C.

$V_{O\_TC} = V_o$  at 25°C after temperature cycle of +25°C to -40°C to +125°C and back to +25°C.



## APPLICATIONS INFORMATION

### LOW COST NEGATIVE REFERENCE

A low cost negative reference can be obtained by leveraging the current sinking capability of the ADR370. By simply tying the  $V_{OUT}$  terminal to ground and adding a bias resistor ( $R_{SET}$ ) to the GND pin of the device, a negative voltage reference can be obtained as shown in Figure 14.  $R_{SET}$  should be chosen such that  $I_{SET}$  remains between 1 mA and 5 mA.

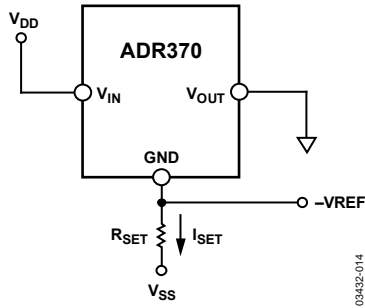

Figure 14. Low Cost Negative Reference

### PRECISION NEGATIVE REFERENCE

Without using any matching resistors, a precision negative reference can be obtained using the configuration shown in Figure 15. The voltage difference between  $V_{OUT}$  and GND of the ADR370 is 2.048 V. Because  $V_{OUT}$  is at virtual ground, U2 closes the loop by forcing the GND pin to be the negative reference node. U2 should be a low offset voltage precision op amp, such as the OP1177.

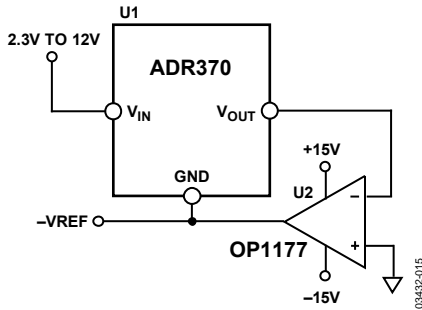

Figure 15. Precision Negative Reference

### LOW COST CURRENT SOURCE

Figure 16 illustrates how a simple, low cost current source can be configured using the ADR370. The load current,  $I_L$ , is simply the sum of  $I_{SET}$  and the quiescent current,  $I_q$ .  $I_{SET}$  is simply the reference voltage generated by the ADR370 divided by  $R_{SET}$ .

$$I_{SET} = \frac{2.048 \text{ V}}{R_{SET}} \quad (4)$$

The quiescent current,  $I_q$ , varies slightly with load. The variation in  $I_q$  limits the use of this circuit to general-purpose applications.

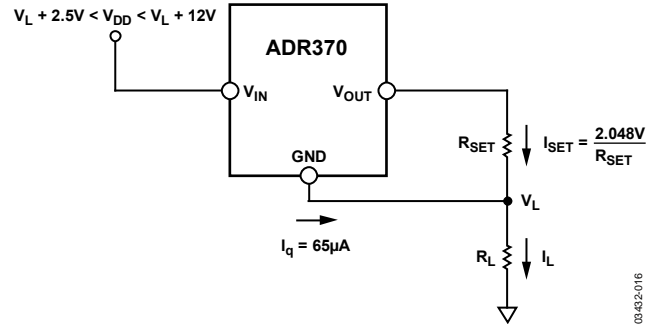

Figure 16. Low Cost Current Source

### PRECISION CURRENT SOURCE WITH ADJUSTABLE OUTPUT

A precision current source can be implemented with the circuit shown in Figure 17. By adding a mechanical or digital potentiometer, this circuit becomes an adjustable current source. If a digital potentiometer such as the AD5201 is used, the load current is simply the voltage across Terminal B-to-Terminal W of the digital potentiometer divided by  $R_{SET}$ .

$$I_L = \frac{V_{REF} \times D}{R_{SET} \times 256} \quad (5)$$

where  $D$  is the decimal equivalent of the digital potentiometer input code.

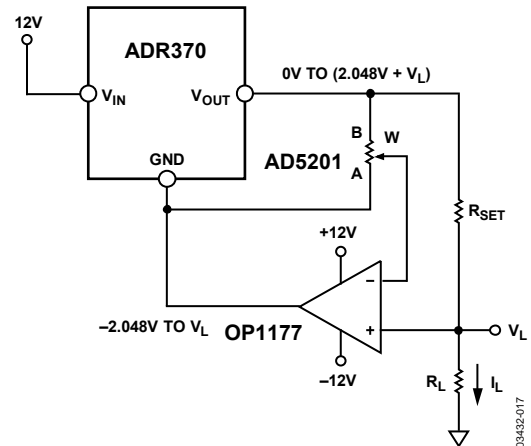

Figure 17. Programmable 0 mA to 5 mA Current Source

To optimize the resolution of this circuit, dual-supply op amps should be used because the ground potential of the ADR370 can swing from  $-2.048 \text{ V}$  at zero scale to  $V_L$  at full scale of the potentiometer setting.

# ADR370

## 12-BIT PRECISION PROGRAMMABLE CURRENT SOURCE

By replacing the potentiometer in Figure 17 with a 12-bit precision DAC, such as the [AD5322](#), a higher precision programmable current source can be achieved. Figure 18 illustrates the implementation of this circuit. The load current can be determined with the following equation:

$$I_L = \frac{V_{REF}(1-D)}{R_{SET} \times 4096} \quad (6)$$

The compliance voltage should be kept low so that the supply voltage to U2, between  $V_{DD}$  and GND, does not fall below 2.5 V.

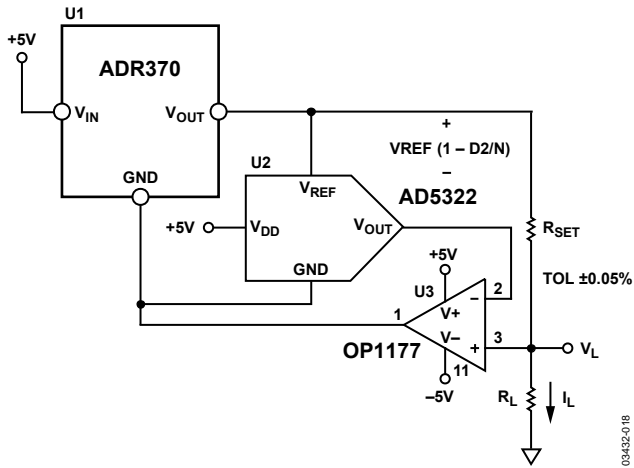

Figure 18. 12-Bit Programmable Current Source

## PRECISION BOOSTED OUTPUT REGULATOR

A precision voltage output with boosted current can be realized with the circuit shown in Figure 19. In this circuit,  $V_{OUT}$  is maintained by the ADR370 at 2.048 V.

The ADR370 sources a maximum of 5 mA if the load current ( $I_L$ ) is more than 5 mA and if the current is furnished by the transistor (Q1) and the input voltage supply ( $V_{DD}$ ).

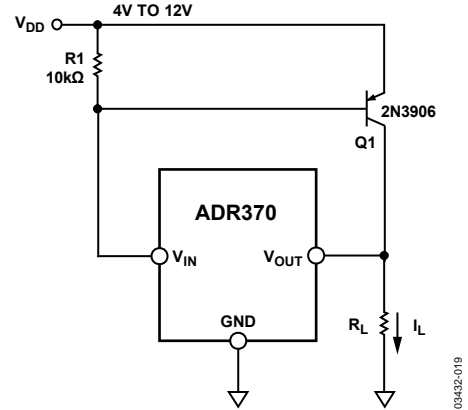

Figure 19. Precision Boosted Output Regulator

Q1 is turned on to regulate current as needed. R1 is required to bias the base of Q1 and must be large enough to comply with the supply current requirements of the ADR370. The supply voltage can be as low as 4 V.

The maximum current output of this circuit is limited by the power dissipation of the bipolar transistor, Q1.

$$P_{DISS} = (V_{DD} - 2.048) \times I_L \quad (7)$$

When using the 2N3906 PNP transistor shown in Figure 19, a 4 V power supply ( $R_L$ ) should be chosen so that a maximum of 100 mA is drawn from the circuit, which limits the power dissipation of Q1 to ~200 mW.

# OUTLINE DIMENSIONS

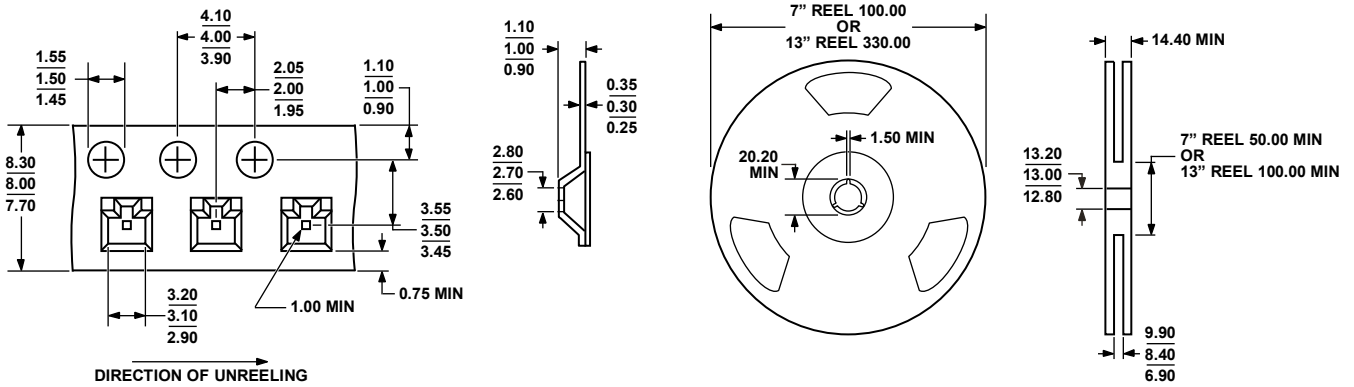
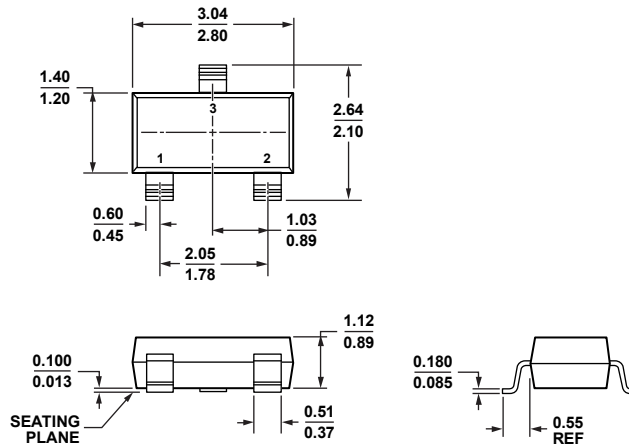

Figure 20. SOT-23-3 Tape and Reel Outline Dimensions  
Dimensions shown in millimeters



COMPLIANT TO JEDEC STANDARDS TO-236-AB

Figure 21. 3-Lead Small Outline Transistor Package [SOT-23-3] (RT-3)

Dimensions shown in millimeters

## ORDERING GUIDE

Model	Output Voltage (V)	Initial Accuracy ±		Temperature Coefficient (ppm/°C)	Temperature Range	Package Description	Package Option	Ordering Quantity	Branding
		(mV)	(%)						
ADR370ART-R2	2.048	10	0.5	100	-40°C to +125°C	3-Lead SOT-23-3	RT-3	250	RPA
ADR370ART-REEL7	2.048	10	0.5	100	-40°C to +125°C	3-Lead SOT-23-3	RT-3	3,000	RPA
ADR370ARTZ-REEL7 <sup>1</sup>	2.048	10	0.5	100	-40°C to +125°C	3-Lead SOT-23-3	RT-3	3,000	L26
ADR370BRT-R2	2.048	4	0.5	50	-40°C to +125°C	3-Lead SOT-23-3	RT-3	250	RPB
ADR370BRT-REEL7	2.048	4	0.2	50	-40°C to +125°C	3-Lead SOT-23-3	RT-3	3,000	RPB
ADR370BRTZ-R2 <sup>1</sup>	2.048	4	0.5	50	-40°C to +125°C	3-Lead SOT-23-3	RT-3	250	L27
ADR370BRTZ-REEL7 <sup>1</sup>	2.048	4	0.2	50	-40°C to +125°C	3-Lead SOT-23-3	RT-3	3,000	L27

<sup>1</sup> Z = RoHS Compliant Part.

**ADR370**

**NOTES**

## Looking for pricing, stock, or lifecycle information?

Click below to explore more details on WIN SOURCE:

- ⊖ [View ADR370ARTZ-REEL7 on WIN SOURCE](#)
- ⊖ [Analog Devices Inc. Information](#)

## Optimize Your Supply Chain with WIN SOURCE Solutions

- ✓ Global Sourcing Solution
- ✓ Obsolete Management
- ✓ Cost Control Management
- ✓ Shortage Management
- ✓ Alternative Solution
- ✓ Excess Inventory Management