



**THE DATASHEET OF
ADT7320UCPZ-RL7**



FEATURES

High performance

Temperature accuracy

±0.20°C from -10°C to +85°C at 3.0 V

±0.25°C from -20°C to +105°C at 2.7 V to 3.3 V

16-bit temperature resolution: 0.0078°C

Ultralow temperature drift: 0.0073°C

NIST traceable or equivalent

Fast first temperature conversion on power-up of 6 ms

Easy implementation

No temperature calibration/correction required by user

No linearity correction required

Low power

Power saving 1 sample per second (SPS) mode

700 μW typical at 3.3 V in normal mode

7 μW typical at 3.3 V in shutdown mode

Wide operating ranges

Temperature range: -40°C to +150°C

Voltage range: 2.7 V to 5.5 V

Programmable interrupts

Critical overtemperature interrupt

Overtemperature/undertemperature interrupt

SPI-compatible interface

16-lead, RoHS-compliant, 4 mm × 4 mm LFCSP package

APPLICATIONS

RTD and thermistor replacement

Thermocouple cold junction compensation

Medical equipment

Industrial control and test

Food transportation and storage

Environmental monitoring and HVAC

Laser diode temperature control

GENERAL DESCRIPTION

The ADT7320 is a high accuracy digital temperature sensor that offers breakthrough performance over a wide industrial temperature range, housed in a 4 mm × 4 mm LFCSP package. It contains an internal band gap reference, a temperature sensor, and a 16-bit analog-to-digital converter (ADC) to monitor and digitize the temperature to a resolution of 0.0078°C. The ADC resolution, by default, is set to 13 bits (0.0625°C). The ADC resolution is a user programmable mode that can be changed through the serial interface.

The ADT7320 is guaranteed to operate over supply voltages from 2.7 V to 5.5 V. Operating at 3.3 V, the average supply current is typically 210 μA. The ADT7320 has a shutdown mode that powers down the device and offers a shutdown current of typically 2.0 μA at 3.3 V. The ADT7320 is rated for operation over the -40°C to +150°C temperature range.

The CT pin is an open-drain output that becomes active when the temperature exceeds a programmable critical temperature limit. The INT pin is also an open-drain output that becomes active when the temperature exceeds a programmable limit. The INT pin and CT pin can operate in either comparator or interrupt mode.

PRODUCT HIGHLIGHTS

1. Ease of use, no calibration or correction required by the user.
2. Low power consumption.
3. Excellent long term stability and reliability.
4. High accuracy for industrial, instrumentation, and medical applications.
5. Packaged in a 16-lead, RoHS-compliant, 4 mm × 4 mm LFCSP package.

FUNCTIONAL BLOCK DIAGRAM

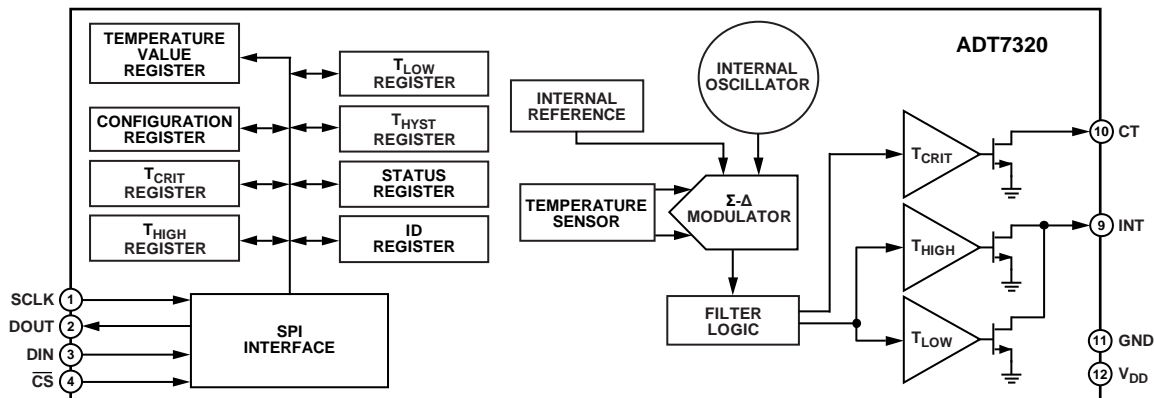

Figure 1.

Rev. 0

[Document Feedback](#)

Information furnished by Analog Devices is believed to be accurate and reliable. However, no responsibility is assumed by Analog Devices for its use, nor for any infringements of patents or other rights of third parties that may result from its use. Specifications subject to change without notice. No license is granted by implication or otherwise under any patent or patent rights of Analog Devices. Trademarks and registered trademarks are the property of their respective owners.

TABLE OF CONTENTS

Features	1	Configuration Register	14
Applications.....	1	Temperature Value Register.....	15
General Description	1	ID Register.....	15
Product Highlights	1	T _{CRIT} Setpoint Register	15
Functional Block Diagram	1	T _{HYST} Setpoint Register.....	16
Revision History	2	T _{HIGH} Setpoint Register	16
Specifications.....	3	T _{LOW} Setpoint Register	16
SPI Timing Specifications	4	Serial Interface	17
Absolute Maximum Ratings.....	5	SPI Command Byte.....	17
ESD Caution.....	5	Writing Data	18
Pin Configuration and Function Descriptions.....	6	Reading Data.....	19
Typical Performance Characteristics	7	Interfacing to DSPs or Microcontrollers.....	19
Theory of Operation	9	Serial Interface Reset.....	19
Circuit Information.....	9	INT and CT Outputs.....	20
Converter Details.....	9	Undertemperature and Overtemperature Detection	20
Continuous Conversion Mode	9	Applications Information	22
One-Shot Mode	10	Thermal Response Time	22
1 SPS Mode.....	11	Supply Decoupling	22
Shutdown Mode.....	11	Powering from a Switching Regulator.....	22
Fault Queue	11	Temperature Measurement.....	22
Temperature Data Format	12	Quick Guide to Measuring Temperature	22
Temperature Conversion Formulas	12	Outline Dimensions	23
Registers	13	Ordering Guide	23
Status Register	13		

REVISION HISTORY

12/12—Revision 0: Initial Version

SPECIFICATIONS

$T_A = -40^{\circ}\text{C}$ to $+125^{\circ}\text{C}$, $V_{DD} = 2.7\text{ V}$ to 5.5 V , unless otherwise noted.

Table 1.

Parameter	Min	Typ	Max	Unit	Test Conditions/Comments
TEMPERATURE SENSOR AND ADC					
Accuracy ¹		0.0017	$\pm 0.20^2$	$^{\circ}\text{C}$	$T_A = -10^{\circ}\text{C}$ to $+85^{\circ}\text{C}$, $V_{DD} = 3.0\text{ V}$
			± 0.25	$^{\circ}\text{C}$	$T_A = -20^{\circ}\text{C}$ to $+105^{\circ}\text{C}$, $V_{DD} = 2.7\text{ V}$ to 3.3 V
			± 0.31	$^{\circ}\text{C}$	$T_A = -40^{\circ}\text{C}$ to $+105^{\circ}\text{C}$, $V_{DD} = 3.0\text{ V}$
			± 0.35	$^{\circ}\text{C}$	$T_A = -40^{\circ}\text{C}$ to $+105^{\circ}\text{C}$, $V_{DD} = 2.7\text{ V}$ to 3.3 V
			± 0.50	$^{\circ}\text{C}$	$T_A = -40^{\circ}\text{C}$ to $+125^{\circ}\text{C}$, $V_{DD} = 2.7\text{ V}$ to 3.3 V
			$\pm 0.50^3$	$^{\circ}\text{C}$	$T_A = -10^{\circ}\text{C}$ to $+105^{\circ}\text{C}$, $V_{DD} = 4.5\text{ V}$ to 5.5 V
			± 0.66	$^{\circ}\text{C}$	$T_A = -40^{\circ}\text{C}$ to $+125^{\circ}\text{C}$, $V_{DD} = 4.5\text{ V}$ to 5.5 V
		-0.85		$^{\circ}\text{C}$	$T_A = +150^{\circ}\text{C}$, $V_{DD} = 4.5\text{ V}$ to 5.5 V
		-1.0		$^{\circ}\text{C}$	$T_A = +150^{\circ}\text{C}$, $V_{DD} = 2.7\text{ V}$ to 3.3 V
ADC Resolution		13		Bits	Twos complement temperature value of sign bit plus 12 ADC bits (power-up default resolution)
		16		Bits	Twos complement temperature value of sign bit plus 15 ADC bits (Bit 7 = 1 in the configuration register)
Temperature Resolution					
13-Bit		0.0625		$^{\circ}\text{C}$	13-bit resolution (sign + 12 bits)
16-Bit		0.0078		$^{\circ}\text{C}$	16-bit resolution (sign + 15 bits)
Temperature Conversion Time		240		ms	Continuous conversion and one-shot conversion mode
Fast Temperature Conversion Time		6		ms	First conversion on power-up only
1 SPS Conversion Time		60		ms	Conversion time for 1 SPS mode
Temperature Hysteresis ⁴		± 0.002		$^{\circ}\text{C}$	Temperature cycle = 25°C to 125°C and back to 25°C
Repeatability ⁵		± 0.015		$^{\circ}\text{C}$	$T_A = 25^{\circ}\text{C}$
Drift ⁶		0.0073		$^{\circ}\text{C}$	500 hour stress test at 150°C with $V_{DD} = 5.0\text{ V}$
DC PSRR		0.1		$^{\circ}\text{C}/\text{V}$	$T_A = 25^{\circ}\text{C}$
DIGITAL OUTPUTS (CT, INT), OPEN DRAIN					
High Output Leakage Current, I_{OH}		0.1	5	μA	CT and INT pins pulled up to 5.5 V
Output Low Voltage, V_{OL}			0.4	V	$I_{OL} = 3\text{ mA}$ at 5.5 V , $I_{OL} = 1\text{ mA}$ at 3.3 V
Output High Voltage, V_{OH}	$0.7 \times V_{DD}$			V	
Output Capacitance, C_{OUT}		2		pF	
DIGITAL INPUTS (DIN, SCLK, $\overline{\text{CS}}$)					
Input Current			± 1	μA	$V_{IN} = 0\text{ V}$ to V_{DD}
Input Low Voltage, V_{IL}			0.4	V	
Input High Voltage, V_{IH}	$0.7 \times V_{DD}$			V	
Pin Capacitance		5	10	pF	
DIGITAL OUTPUT (DOUT)					
Output High Voltage, V_{OH}	$V_{DD} - 0.3$			V	$I_{SOURCE} = I_{SINK} = 200\ \mu\text{A}$
Output Low Voltage, V_{OL}			0.4	V	$I_{OL} = 200\ \mu\text{A}$
Output Capacitance, C_{OUT}			50	pF	
POWER REQUIREMENTS					
Supply Voltage	2.7		5.5	V	
Supply Current					Peak current while converting, SPI interface inactive
At 3.3 V		210	265	μA	
At 5.5 V		250	300	μA	
1 SPS Current					1 SPS mode, $T_A = 25^{\circ}\text{C}$
At 3.3 V		46		μA	$V_{DD} = 3.3\text{ V}$
At 5.5 V		65		μA	$V_{DD} = 5.5\text{ V}$

Parameter	Min	Typ	Max	Unit	Test Conditions/Comments
Shutdown Current					Supply current in shutdown mode
At 3.3 V		2.0	15	μA	
At 5.5 V		5.2	25	μA	
Power Dissipation, Normal Mode		700		μW	V _{DD} = 3.3 V, normal mode at 25°C
Power Dissipation, 1 SPS Mode		150		μW	Power dissipated for V _{DD} = 3.3 V, T _A = 25°C

¹ Accuracy specification includes repeatability.
² The equivalent 3 σ limits are ±0.15°C. This 3 σ specification is provided to enable comparison with other vendors who use these limits.
³ For higher accuracy at 5 V operation, contact Analog Devices, Inc.
⁴ Temperature hysteresis does not include repeatability.
⁵ Based on a floating average of 10 readings.
⁶ Drift includes solder heat resistance and lifetime test performed as per JEDEC Standard JESD22-A108.

SPI TIMING SPECIFICATIONS

T_A = -40°C to +150°C, V_{DD} = 2.7 V to 5.5 V, unless otherwise noted. All input signals are specified with rise time (t_R) = fall time (t_F) = 5 ns (10% to 90% of V_{DD}) and timed from a voltage level of 1.6 V.

Table 2.

Parameter ^{1,2}	Limit at T _{MIN} , T _{MAX}	Unit	Descriptions
t ₁	0	ns min	\overline{CS} falling edge to SCLK active edge setup time
t ₂	100	ns min	SCLK high pulse width
t ₃	100	ns min	SCLK low pulse width
t ₄	30	ns min	Data setup time prior to SCLK rising edge
t ₅	25	ns min	Data hold time after SCLK rising edge
t ₆	5	ns min	Data access time after SCLK falling edge
	60	ns max	V _{DD} = 4.5 V to 5.5 V
	80	ns max	V _{DD} = 2.7 V to 3.6 V
t ₇ ³	10	ns min	Bus relinquish time after \overline{CS} inactive edge
	80	ns max	Bus relinquish time after \overline{CS} inactive edge
t ₈	0	ns min	SCLK inactive edge to \overline{CS} rising edge hold time
t ₉	0	ns min	\overline{CS} falling edge to DOUT active time
	60	ns max	V _{DD} = 4.5 V to 5.5 V
	80	ns max	V _{DD} = 2.7 V to 3.6 V
t ₁₀	10	ns min	SCLK inactive edge to DOUT low

¹ Sample tested during initial release to ensure compliance.
² See Figure 2.
³ This means that the times quoted in the timing characteristics in Table 2 are the true bus relinquish times of the part and, as such, are independent of external bus loading capacitances.

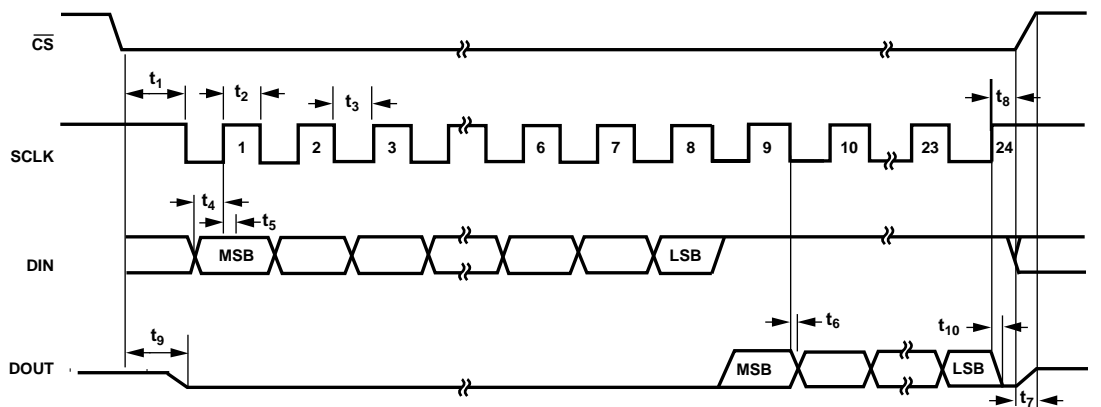

Figure 2. Detailed SPI Timing Diagram

ABSOLUTE MAXIMUM RATINGS

Table 3.

Parameter	Rating
V _{DD} to GND	−0.3 V to +7 V
DIN Input Voltage to GND	−0.3 V to V _{DD} + 0.3 V
DOOUT Voltage to GND	−0.3 V to V _{DD} + 0.3 V
SCLK Input Voltage to GND	−0.3 V to V _{DD} + 0.3 V
CS Input Voltage to GND	−0.3 V to V _{DD} + 0.3 V
CT and INT Output Voltage to GND	−0.3 V to V _{DD} + 0.3 V
ESD Rating (Human Body Model)	2.0 kV
Operating Temperature Range ¹	−40°C to +150°C
Storage Temperature Range	−65°C to +160°C
Maximum Junction Temperature, T _{JMAX}	150°C
Power Dissipation ²	
16-Lead LFCSP ³	$W_{MAX} = (T_{JMAX} - T_A)/\theta_{JA}$
Thermal Impedance ⁴	
θ _{JA} , Junction-to-Ambient (Still Air)	37°C/W
θ _{JC} , Junction-to-Case	33°C/W
IR Reflow Soldering	220°C
Peak Temperature (RoHS-Compliant Package)	260°C (0°C/−5°C)
Time at Peak Temperature	20 sec to 40 sec
Ramp-Up Rate	3°C/sec maximum
Ramp-Down Rate	−6°C/sec maximum
Time from 25°C to Peak Temperature	8 minutes maximum

¹ Sustained operation above 125°C results in a shorter product lifetime. For more information, contact an Analog Devices, Inc., sales representative.

² Values relate to package being used on a standard 2-layer PCB. This gives a worst-case θ_{JA} and θ_{JC}.

³ T_A = ambient temperature.

⁴ Junction-to-case resistance is applicable to components featuring a preferential flow direction, for example, components mounted on a heat sink. Junction-to-ambient resistance is more useful for air cooled, PCB-mounted components.

Stresses above those listed under Absolute Maximum Ratings may cause permanent damage to the device. This is a stress rating only; functional operation of the device at these or any other conditions above those indicated in the operational section of this specification is not implied. Exposure to absolute maximum rating conditions for extended periods may affect device reliability.

ESD CAUTION



ESD (electrostatic discharge) sensitive device. Charged devices and circuit boards can discharge without detection. Although this product features patented or proprietary protection circuitry, damage may occur on devices subjected to high energy ESD. Therefore, proper ESD precautions should be taken to avoid performance degradation or loss of functionality.

PIN CONFIGURATION AND FUNCTION DESCRIPTIONS

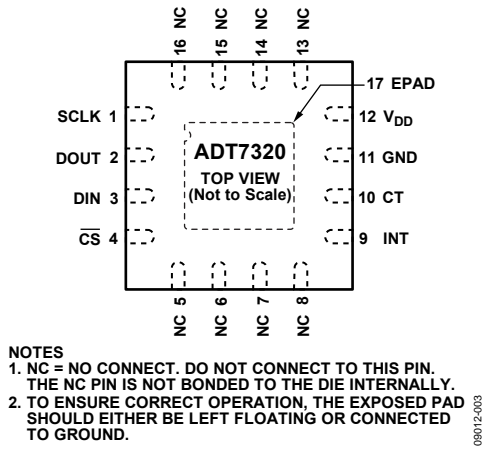

Figure 3. Pin Configuration

Table 4. Pin Function Descriptions

Pin No.	Mnemonic	Description
1	SCLK	Serial Clock Input. The serial clock is used to clock data into and out of any register of the ADT7320 .
2	DOUT	Serial Data Output. Data is clocked out on the SCLK falling edge and is valid on the SCLK rising edge.
3	DIN	Serial Data Input. Serial data to be loaded to the control registers of the part is provided on this input. Data is clocked into the registers on the rising edge of SCLK.
4	\overline{CS}	Chip Select Input. The device is enabled when this input is low. The device is disabled when this pin is high.
5	NC	No Connect. Do not connect to this pin. The NC pin is not bonded to the die internally.
6	NC	No Connect. Do not connect to this pin. The NC pin is not bonded to the die internally.
7	NC	No Connect. Do not connect to this pin. The NC pin is not bonded to the die internally.
8	NC	No Connect. Do not connect to this pin. The NC pin is not bonded to the die internally.
9	INT	Overtemperature and Undertemperature Interrupt. Logic output. Power-up default setting is as an active low comparator interrupt. Open-drain configuration. A pull-up resistor is required, typically 10 k Ω .
10	CT	Critical Overtemperature Interrupt. Logic output. Power-up default polarity is active low. Open-drain configuration. A pull-up resistor is required, typically 10 k Ω .
11	GND	Analog and Digital Ground.
12	V _{DD}	Positive Supply Voltage (2.7 V to 5.5 V). Decouple the supply with a 0.1 μ F ceramic capacitor to GND.
13	NC	No Connect. Do not connect to this pin. The NC pin is not bonded to the die internally.
14	NC	No Connect. Do not connect to this pin. The NC pin is not bonded to the die internally.
15	NC	No Connect. Do not connect to this pin. The NC pin is not bonded to the die internally.
16	NC	No Connect. Do not connect to this pin. The NC pin is not bonded to the die internally.
17	EPAD	Exposed Pad. To ensure correct operation, the exposed pad should either be left floating or connected to ground.

TYPICAL PERFORMANCE CHARACTERISTICS

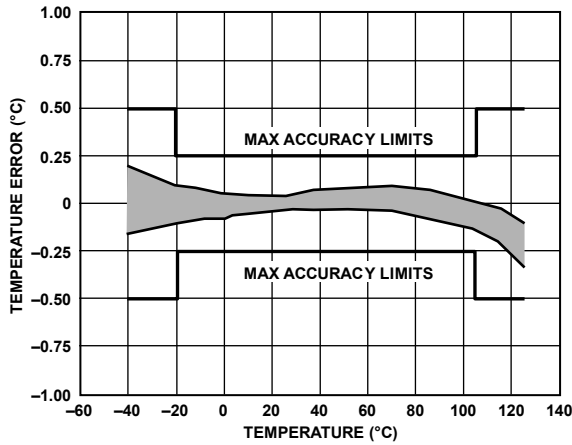

Figure 4. Temperature Accuracy at 3 V

09012-027

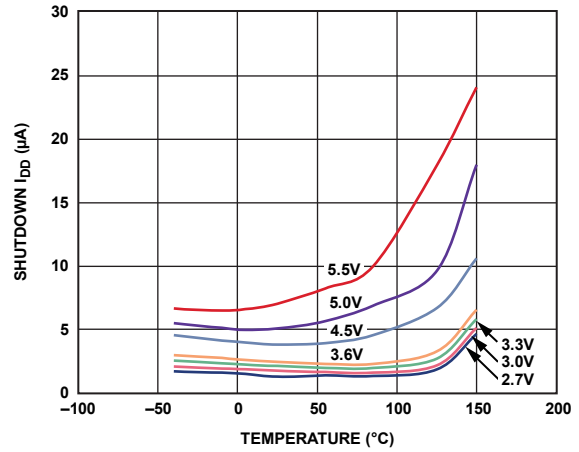

Figure 7. Shutdown Current vs. Temperature

09012-032

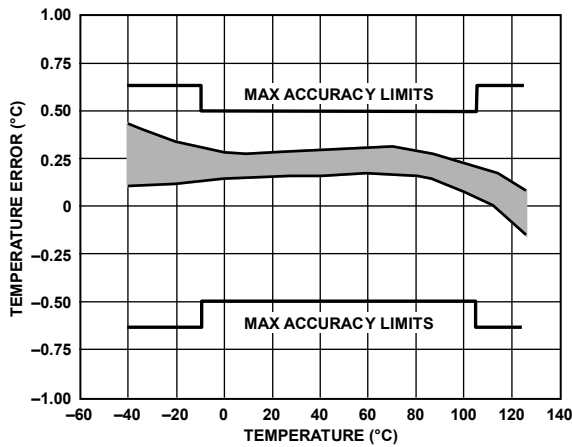

Figure 5. Temperature Accuracy at 5 V

09012-028

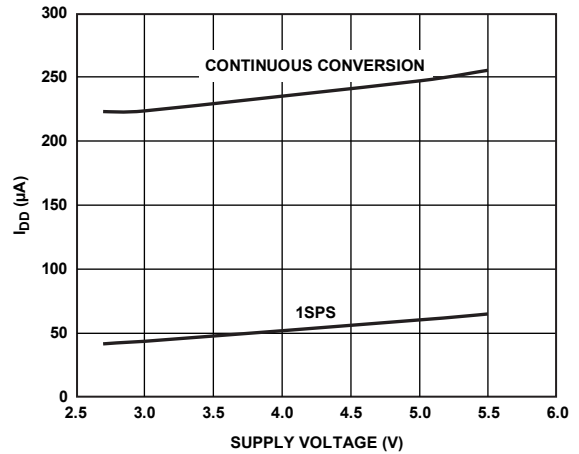

Figure 8. Average Operating Supply Current vs. Supply Voltage

09012-029

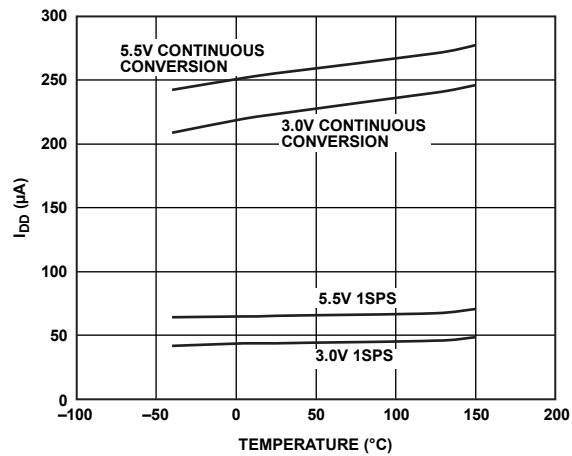

Figure 6. Operating Supply Current vs. Temperature

09012-028

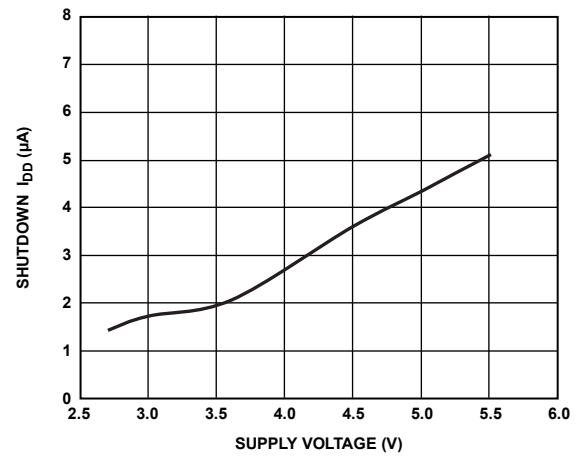

Figure 9. Shutdown Current vs. Supply Voltage

09012-210

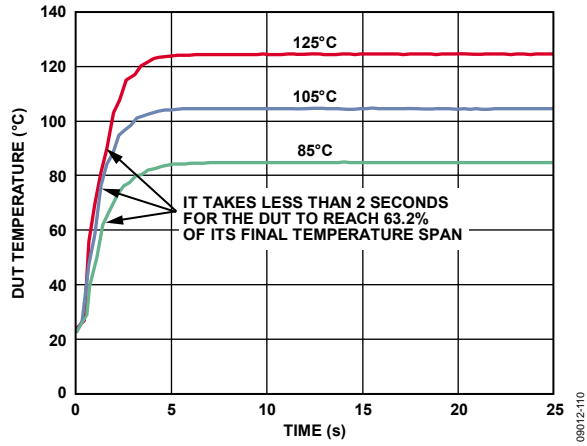

Figure 10. Thermal Response Time

THEORY OF OPERATION

CIRCUIT INFORMATION

The ADT7320 is a high accuracy digital temperature sensor that uses a 16-bit ADC to monitor and digitize the temperature to a resolution of 0.0078°C. By default, the ADC resolution is set to 13 bits (0.0625°C). An internal temperature sensor generates a voltage proportional to absolute temperature; this voltage is compared to an internal voltage reference and input into a precision digital modulator.

The internal temperature sensor has high accuracy and linearity over the entire rated temperature range without the need for correction or calibration by the user.

The sensor output is digitized by a sigma-delta (Σ - Δ) modulator, also known as the charge balance type ADC. This type of converter uses time domain oversampling and a high accuracy comparator to deliver 16 bits of resolution in an extremely compact circuit.

CONVERTER DETAILS

The Σ - Δ modulator consists of an input sampler, a summing network, an integrator, a comparator, and a 1-bit digital-to-analog converter (DAC). This architecture creates a negative feedback loop and minimizes the integrator output by changing the duty cycle of the comparator output in response to the input voltage changes. The comparator samples the output of the integrator at a much higher rate than the input sampling frequency. This oversampling spreads the quantization noise over a much wider band than that of the input signal, improving overall noise performance and increasing accuracy.

The modulated output of the comparator is encoded using a circuit technique that results in SPI temperature data.

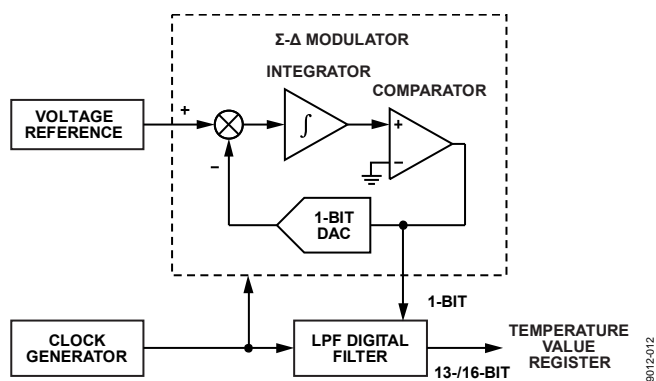

Figure 11. Σ - Δ Modulator

The ADT7320 can be configured to operate in any one of the following four operating modes: normal mode, one-shot mode, 1 SPS mode, and shutdown mode.

CONTINUOUS CONVERSION MODE

In continuous conversion mode (default power-up mode), the ADT7320 runs an automatic conversion sequence. During this automatic conversion sequence, a conversion takes 240 ms to complete and the ADT7320 is continuously converting. This means that as soon as one temperature conversion is completed, another temperature conversion begins. Each temperature conversion result is stored in the temperature value register and is available through the SPI interface. In continuous conversion mode, the read operation provides the most recent converted result.

On power-up, the first conversion is a fast conversion, taking typically 6 ms. If the temperature exceeds 147°C, the CT pin is asserted low. If the temperature exceeds 64°C, the INT pin is asserted low. Fast conversion temperature accuracy is typically within $\pm 5^\circ\text{C}$.

The conversion clock for the part is generated internally. No external clock is required except when reading from and writing to the serial port.

The measured temperature value is compared with a critical temperature limit (stored in the 16-bit T_{CRIT} setpoint register), a high temperature limit (stored in the 16-bit T_{HIGH} setpoint register), and a low temperature limit (stored in the 16-bit T_{LOW} setpoint register). If the measured value exceeds the high or low temperature limits, the INT pin is activated; if it exceeds the T_{CRIT} limit, the CT pin is activated. The polarity of the INT and CT pins is programmable for via the configuration register, and the INT and CT pins are also programmable for interrupt mode via the configuration register.

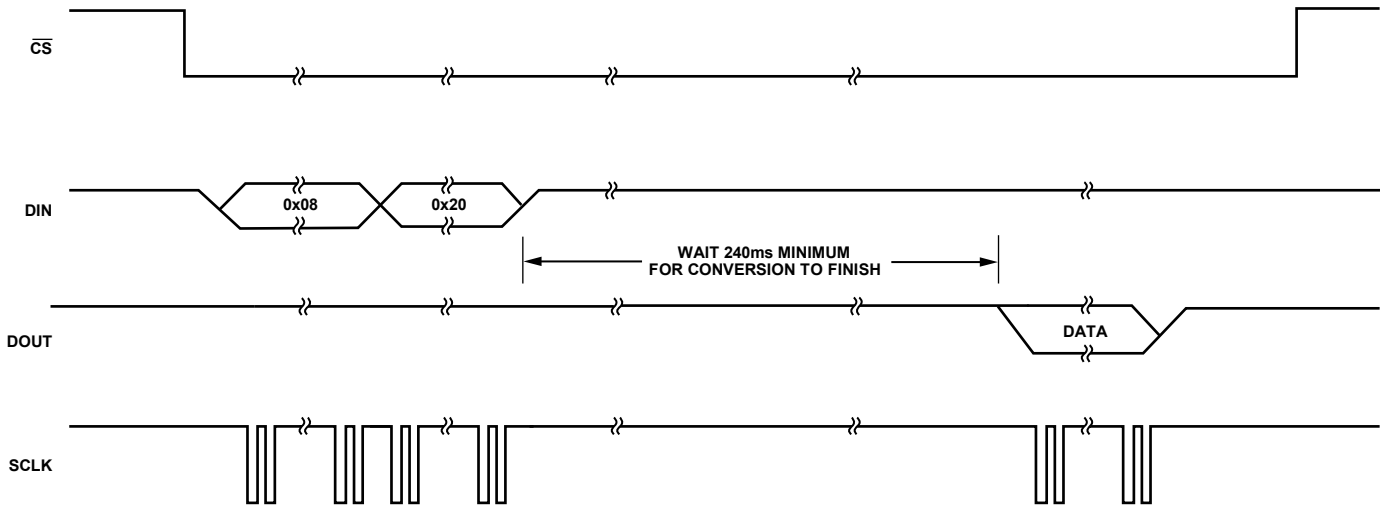

Figure 12. Typical SPI One-Shot Write to Configuration Register Followed by a Read from the Temperature Value Register

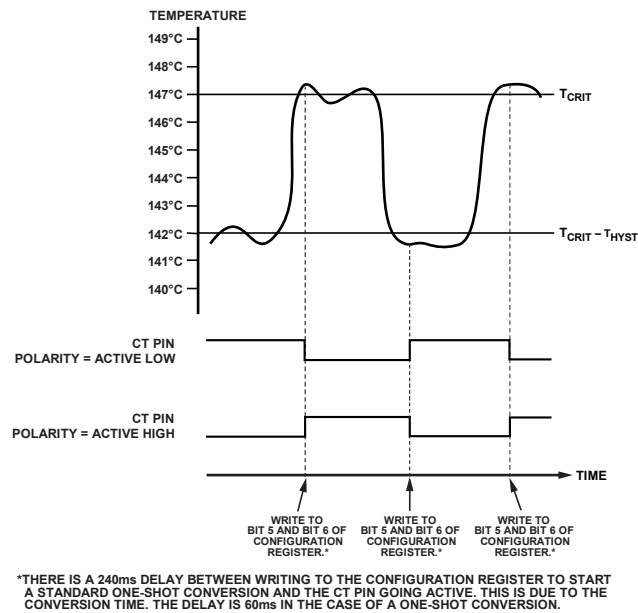

Figure 13. One-Shot CT Pin

ONE-SHOT MODE

When one-shot mode is enabled, the ADT7320 immediately completes a conversion and then goes into shutdown mode. The one-shot mode is useful when one of the circuit design priorities is to reduce power consumption.

To enable one-shot mode, set Bits [6:5] of the configuration register (Register Address 0x01) to 01.

After writing to the operation mode bits, wait for at least 240 ms before reading back the temperature from the temperature value register. This delay ensures that the ADT7320 has adequate time to power up and complete a conversion.

To obtain an updated temperature conversion, reset Bits[6:5] of the configuration register (Register Address 0x01) to 01.

CT and INT Operation in One-Shot Mode

See Figure 13 for more information on one-shot CT pin operation for T_{CRIT} overtemperature events when one of the limits is exceeded. Note that in interrupt mode, a read from any register resets the INT and CT pins.

For the INT pin in comparator mode, if the temperature drops below the $T_{HIGH} - T_{HYST}$ value or goes above the $T_{LOW} + T_{HYST}$ value, a write to the operation mode bits (Bit 5 and Bit 6 of the configuration register, Register Address 0x01) resets the INT pin.

For the CT pin in comparator mode, if the temperature drops below the $T_{CRIT} - T_{HYST}$ value, a write to the operation mode bits (Bit 5 and Bit 6 of the configuration register, Register Address 0x01) resets the CT pin (see Figure 13).

When using one-shot mode, ensure that the refresh rate is appropriate to the application being used.

1 SPS MODE

In 1 SPS mode, the part performs one measurement per second. A conversion takes 60 ms typically, and the part remains in the idle state for the remaining 940 ms period. This mode is enabled by setting Bits[6:5] of the configuration register (Register Address 0x01) to 10.

SHUTDOWN MODE

The ADT7320 can be placed in shutdown mode by setting Bits[6:5] of the configuration register (Register Address 0x01) to 11. The ADT7320 can be taken out of shutdown mode by setting Bits[6:5] of the configuration register (Register Address 0x01) to 00. The ADT7320 typically takes 1 ms (with a 0.1 μ F decoupling capacitor) to come out of shut-down mode. The conversion result from the last conversion prior to shutdown can still be read from the ADT7320 even when it is in shutdown mode. When the part is taken out of shutdown mode, the internal clock restarts and a conversion is initiated.

FAULT QUEUE

Bit 0 and Bit 1 of the configuration register (Register Address 0x01) are used to set up a fault queue. Up to four faults are provided to prevent false tripping of the INT and CT pins when the ADT7320 is used in a noisy temperature environment. The number of faults set in the queue must occur consecutively to set the INT and CT outputs. For example, if the number of faults set in the queue is four, then four consecutive temperature conversions must occur, with each result exceeding a temperature limit set in any of the limit registers, before the INT and CT pins are activated. If two consecutive temperature conversions exceed a temperature limit and the third conversion does not, the fault count is reset to zero.

TEMPERATURE DATA FORMAT

One LSB of the ADC corresponds to 0.0625°C in 13-bit mode or 0.0078°C in 16-bit mode. The ADC can theoretically measure a temperature range of 255°C, but the ADT7320 is guaranteed to measure a low value temperature limit of -40°C to a high value temperature limit of +150°C. The temperature measurement result is stored in the 16-bit temperature value register and is compared with the high temperature limits stored in the T_{CRIT} setpoint register and the T_{HIGH} setpoint register. It is also compared with the low temperature limit stored in the T_{LOW} setpoint register.

Temperature data in the temperature value register, the T_{CRIT} setpoint register, the T_{HIGH} setpoint register, and the T_{LOW} setpoint register are represented by a 13-bit, twos complement word. The MSB is the temperature sign bit. On power-up the three LSBs, Bit 0 to Bit 2, are not part of the temperature conversion result and are flag bits for T_{CRIT}, T_{HIGH}, and T_{LOW}. Table 5 shows the 13-bit temperature data format without Bit 0 to Bit 2.

The number of bits in the temperature data-word can be extended to 16 bits, twos complement by setting Bit 7 to 1 in the configuration register (Register Address 0x01). When using a 16-bit temperature data value, Bit 0 to Bit 2 are not used as flag bits and are instead the LSB bits of the temperature value. The power-on default setting has a 13-bit temperature data value.

Reading back the temperature from the temperature value register requires a 2-byte read. Designers that use a 9-bit temperature data format can still use the ADT7320 by ignoring the last four LSBs of the 13-bit temperature value. These four LSBs are Bit 3 to Bit 6 in Table 5.

Table 5. 13-Bit Temperature Data Format

Temperature	Digital Output (Binary) Bits[15:3]
-40°C	1 1101 1000 0000
-25°C	1 1110 0111 0000
-0.0625°C	1 1111 1111 1111
0°C	0 0000 0000 0000
+0.0625°C	0 0000 0000 0001
+25°C	0 0001 1001 0000
+105°C	0 0110 1001 0000
+125°C	0 0111 1101 0000
+150°C	0 1001 0110 0000

TEMPERATURE CONVERSION FORMULAS

16-Bit Temperature Data Format

$$\text{Positive Temperature} = \text{ADC Code (dec)}/128$$

$$\text{Negative Temperature} = (\text{ADC Code (dec)} - 65,536)/128$$

where ADC Code uses all 16 bits of the data byte, including the sign bit.

$$\text{Negative Temperature} = (\text{ADC Code (dec)} - 32,768)/128$$

where the MSB is removed from the ADC code.

13-Bit Temperature Data Format

$$\text{Positive Temperature} = \text{ADC Code (dec)}/16$$

$$\text{Negative Temperature} = (\text{ADC Code (dec)} - 8192)/16$$

where ADC Code uses all 13 bits of the data byte, including the sign bit.

$$\text{Negative Temperature} = (\text{ADC Code (dec)} - 4096)/16$$

where the MSB is removed from the ADC code.

10-Bit Temperature Data Format

$$\text{Positive Temperature} = \text{ADC Code (dec)}/2$$

$$\text{Negative Temperature} = (\text{ADC Code (dec)} - 1024)/2$$

where ADC Code uses all 10 bits of the data byte, including the sign bit.

$$\text{Negative Temperature} = (\text{ADC Code (dec)} - 512)/2$$

where the MSB is removed from the ADC Code.

9-Bit Temperature Data Format

$$\text{Positive Temperature} = \text{ADC Code (dec)}$$

$$\text{Negative Temperature} = \text{ADC Code (dec)} - 512$$

where ADC Code uses all nine bits of the data byte, including the sign bit.

$$\text{Negative Temperature} = \text{ADC Code (dec)} - 256$$

where the MSB is removed from the ADC Code.

REGISTERS

The ADT7320 contains eight registers:

- A status register
- A configuration register
- Five temperature registers
- An ID register

The status register, temperature value register, and the ID register are read only.

Table 6. ADT7320 Registers

Register Address	Description	Power-On Default
0x00	Status	0x80
0x01	Configuration	0x00
0x02	Temperature value	0x0000
0x03	ID	0xC3
0x04	T _{CRIT} setpoint	0x4980 (147°C)
0x05	T _{HYST} setpoint	0x05 (5°C)
0x06	T _{HIGH} setpoint	0x2000 (64°C)
0x07	T _{LOW} setpoint	0x0500 (10°C)

STATUS REGISTER

This 8-bit read-only register (Register Address 0x00) reflects the status of the overtemperature and undertemperature interrupts that can cause the CT and INT pins to become active. It also reflects the status of a temperature conversion operation. The interrupt flags in this register are reset by a read operation to the status register and/or when the temperature value returns within the temperature limits including hysteresis. The RDY bit is reset after a read from the temperature value register. In one-shot and 1 SPS modes, the RDY bit is reset after a write to the operation mode bits in the configuration register.

Table 7. Status Register (Register Address 0x00)

Bit(s)	Default Value	Type	Name	Description
[3:0]	0000	R	Unused	Reads back 0.
[4]	0	R	T _{LOW}	This bit is set to 1 when the temperature goes below the T _{LOW} temperature limit. The bit is cleared to 0 when the status register is read and/or when the temperature measured rises above the limit set in the T _{LOW} + T _{HYST} setpoint registers.
[5]	0	R	T _{HIGH}	This bit is set to 1 when the temperature rises above the T _{HIGH} temperature limit. This bit is cleared to 0 when the status register is read and/or when the temperature measured drops below the limit set in the T _{HIGH} – T _{HYST} setpoint registers.
[6]	0	R	T _{CRIT}	This bit is set to 1 when the temperature rises above the T _{CRIT} temperature limit. This bit is cleared to 0 when the status register is read and/or when the temperature measured drops below the limit set in the T _{CRIT} – T _{HYST} setpoint registers.
[7]	1	R	RDY	This bit goes low when the temperature conversion result is written to the temperature value register. It is reset to 1 when the temperature value register is read. In one-shot and 1 SPS modes, this bit is reset after a write to the operation mode bits in the configuration register.

CONFIGURATION REGISTER

This 8-bit read/write register (Register Address 0x01) stores various configuration modes for the [ADT7320](#), including shutdown, overtemperature and undertemperature interrupts, one-shot, continuous conversion, interrupt pin polarity, and overtemperature fault queues.

Table 8. Configuration Register (Register Address 0x01)

Bit(s)	Default Value	Type	Name	Description
[1:0]	00	R/W	Fault queue	These two bits set the number of undertemperature/overtemperature faults that can occur before setting the INT and CT pins. This helps to avoid false triggering due to temperature noise. 00 = 1 fault (default). 01 = 2 faults. 10 = 3 faults. 11 = 4 faults.
[2]	0	R/W	CT pin polarity	This bit selects the output polarity of the CT pin. 0 = active low. 1 = active high.
[3]	0	R/W	INT pin polarity	This bit selects the output polarity of the INT pin. 0 = active low. 1 = active high.
[4]	0	R/W	INT/CT mode	This bit selects comparator mode or interrupt mode. 0 = interrupt mode. 1 = comparator mode.
[6:5]	00	R/W	Operation mode	These two bits set the operational mode of the ADT7320 . 00 = continuous conversion (default). When one conversion is finished, the ADT7320 begins the next conversion. 01 = one-shot mode. Conversion time is typically 240 ms. 10 = 1 SPS mode. Conversion time is typically 60 ms. This operational mode reduces the average current consumption. 11 = shutdown. All circuitry except for the interface circuitry is powered down.
[7]	0	R/W	Resolution	This bit sets the resolution of the ADC when converting. 0 = 13-bit resolution. Sign bit + 12 bits gives a temperature resolution of 0.0625°C. 1 = 16-bit resolution. Sign bit + 15 bits gives a temperature resolution of 0.0078°C.

TEMPERATURE VALUE REGISTER

The temperature value register stores the temperature measured by the internal temperature sensor. The temperature is stored in a 16-bit, twos complement format. The temperature is read back from the temperature value register (Register Address 0x02) as a 16-bit value.

Bit 2, Bit 1, and Bit 0 are event alarm flags for T_{CRIT} , T_{HIGH} , and T_{LOW} , respectively. When the ADC is configured to convert the temperature to a 16-bit digital value, Bit 2, Bit 1, and Bit 0 are no longer used as flag bits and are, instead, used as the LSB bits for the extended digital value.

ID REGISTER

This 8-bit read-only register (Register Address 0x03) stores the manufacturer ID in Bit 7 to Bit 3 and the silicon revision in Bit 2 to Bit 0. The default setting for the ID register is 0xC3.

T_{CRIT} SETPOINT REGISTER

The 16-bit T_{CRIT} setpoint register (Register Address 0x04) stores the critical overtemperature limit value. A critical overtemperature event occurs when the temperature value stored in the temperature value register exceeds the value stored in this register. The CT pin is activated if a critical overtemperature event occurs. The temperature is stored in twos complement format with the MSB being the temperature sign bit.

The default setting for the T_{CRIT} setpoint is 147°C.

Table 9. Temperature Value Register (Register Address 0x02)

Bit(s)	Default Value	Type	Name	Description
[0]	0	R	T_{LOW} flag/LSB0	Flags a T_{LOW} event if the configuration register, Register Address 0x01[7] = 0 (13-bit resolution). When the temperature value is below T_{LOW} , this bit is set to 1. Contains Least Significant Bit 0 of the 15-bit temperature value when the configuration register, Register Address 0x01[7] = 1 (16-bit resolution).
[1]	0	R	T_{HIGH} flag/LSB1	Flags a T_{HIGH} event if the configuration register, Register Address 0x01[7] = 0 (13-bit resolution). When the temperature value is above T_{HIGH} , this bit is set to 1. Contains Least Significant Bit 1 of the 15-bit temperature value when the configuration register, Register Address 0x01[7] = 1 (16-bit resolution).
[2]	0	R	T_{CRIT} flag/LSB2	Flags a T_{CRIT} event if the configuration register, Register Address 0x01[7] = 0 (13-bit resolution). When the temperature value exceeds T_{CRIT} , this bit is set to 1. Contains the Least Significant Bit 2 of the 15-bit temperature value if the configuration register, Register Address 0x01[7] = 1 (16-bit resolution).
[7:3]	00000	R	Temp	Temperature value in twos complement format.
[14:8]	0000000	R	Temp	Temperature value in twos complement format.
15	0	R	Sign	Sign bit; indicates if the temperature value is negative or positive.

Table 10. ID Register (Register Address 0x03)

Bit(s)	Default Value	Type	Name	Description
[2:0]	011	R	Revision ID	Contains the silicon revision identification number.
[7:3]	11000	R	Manufacturer ID	Contains the manufacturer identification number.

Table 11. T_{CRIT} Setpoint Register (Register Address 0x04)

Bit(s)	Default Value	Type	Name	Description
[15:0]	0x4980	R/W	T_{CRIT}	16-bit critical overtemperature limit, stored in twos complement format.

T_{HYST} SETPOINT REGISTER

The 8-bit T_{HYST} setpoint register (Register Address 0x05) stores the temperature hysteresis value for the T_{HIGH}, T_{LOW}, and T_{CRIT} temperature limits. The temperature hysteresis value is stored in straight binary format using the four LSBs. Increments are possible in steps of 1°C from 0°C to 15°C. The value in this register is subtracted from the T_{HIGH} and T_{CRIT} values and added to the T_{LOW} value to implement hysteresis.

The default setting for the T_{HYST} setpoint is 5°C.

T_{HIGH} SETPOINT REGISTER

The 16-bit T_{HIGH} setpoint register (Register Address 0x06) stores the overtemperature limit value. An overtemperature event occurs when the temperature value stored in the temperature value register exceeds the value stored in this register. The INT pin is activated if an overtemperature event occurs. The temperature is stored in twos complement format with the most significant bit being the temperature sign bit.

The default setting for the T_{HIGH} setpoint is 64°C.

T_{LOW} SETPOINT REGISTER

The 16-bit T_{LOW} setpoint register (Register Address 0x07) stores the undertemperature limit value. An undertemperature event occurs when the temperature value stored in the temperature value register is less than the value stored in this register. The INT pin is activated if an undertemperature event occurs. The temperature is stored in twos complement format with the MSB being the temperature sign bit.

The default setting for the T_{LOW} setpoint is 10°C.

Table 12. T_{HYST} Setpoint Register (Register Address 0x05)

Bit(s)	Default Value	Type	Name	Description
[3:0]	0101	R/W	T _{HYST}	Hysteresis value, from 0°C to 15°C. Stored in straight binary format. The default setting is 5°C.
[7:4]	0000	R/W	N/A	N/A = not applicable. Not used.

Table 13. T_{HIGH} Setpoint Register (Register Address 0x06)

Bit(s)	Default Value	Type	Name	Description
[15:0]	0x2000	R/W	T _{HIGH}	16-bit overtemperature limit, stored in twos complement format.

Table 14. T_{LOW} Setpoint Register (Register Address 0x07)

Bit(s)	Default Value	Type	Name	Description
[15:0]	0x0500	R/W	T _{LOW}	16-bit undertemperature limit, stored in twos complement format.

SERIAL INTERFACE

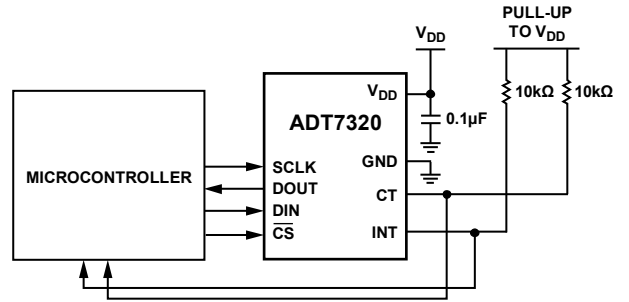

Figure 14. Typical SPI Interface Connection

09012-014

The ADT7320 has a 4-wire serial peripheral interface (SPI). The interface has a data input pin (DIN) for writing data to the device, a data output pin (DOUT) for reading data back from the device, and a serial data clock pin (SCLK) for clocking data into and out of the device. A chip select pin (CS) enables or disables the serial interface. CS is required for correct operation of the interface. Data is clocked out of the ADT7320 on the falling edge of SCLK, and data is clocked into the device on the rising edge of SCLK.

SPI COMMAND BYTE

All data transactions on the bus begin with the master taking CS from high to low and sending out the command byte. The command byte indicates to the ADT7320 whether the transaction is a read or a write and provides the address of the register for the data transfer. Table 15 shows the command byte.

Table 15. Command Byte

C7	C6	C5	C4	C3	C2	C1	C0
0	R/W	Register address			0	0	0

Bit C7, Bit C2, Bit C1, and Bit C0 of the command byte must all be set to 0 to successfully begin a bus transaction. The SPI interface does not work correctly if a 1 is written into any of these bits.

Bit C6 is the read/write bit; 1 indicates a read, and 0 indicates a write.

Bits[C5:C3] contain the target register address. One register can be read from or written to per bus transaction.

WRITING DATA

Data is written to the ADT7320 in 8 bits or 16 bits, depending on the addressed register. The first byte written to the device is the command byte, with the read/write bit set to 0. The master then supplies the 8-bit or 16-bit input data on the DIN line. The ADT7320 clocks the data into the register addressed in the command byte on the rising edge of SCLK. The master finishes the write transaction by pulling CS high.

Figure 15 shows a write to an 8-bit register, and Figure 16 shows a write to a 16-bit register.

The master must begin a new write transaction on the bus for every register write. Only one register is written to per bus transaction.

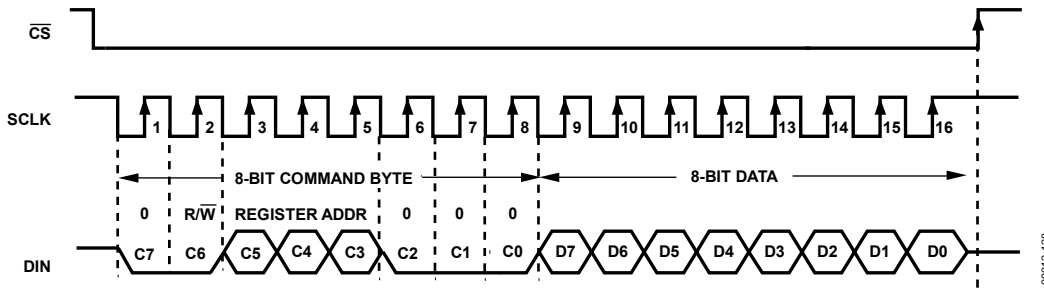

Figure 15. Writing to an 8-Bit Register

08012-128

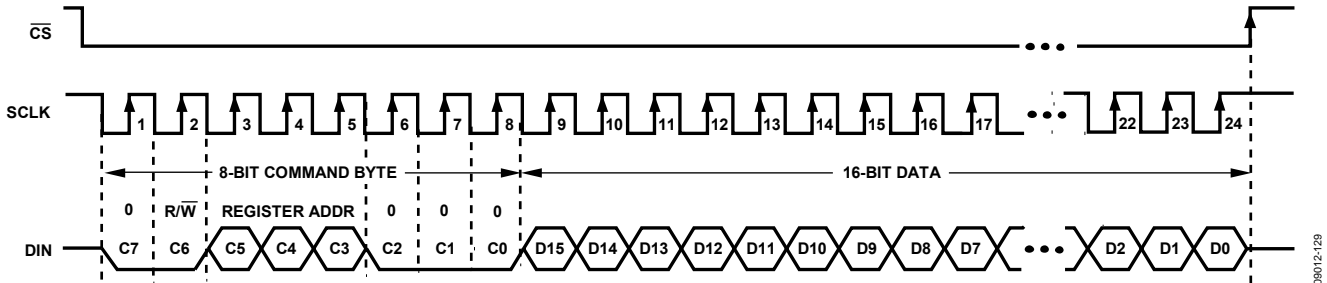

Figure 16. Writing to a 16-Bit Register

08012-129

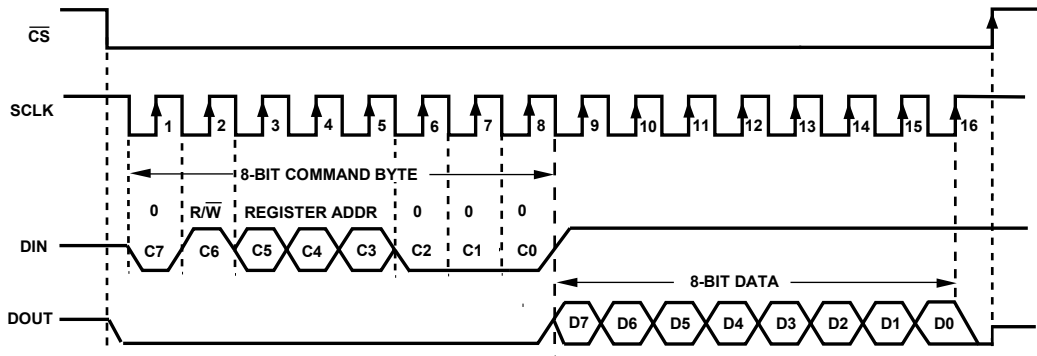

Figure 17. Reading from an 8-Bit Register

09012-030

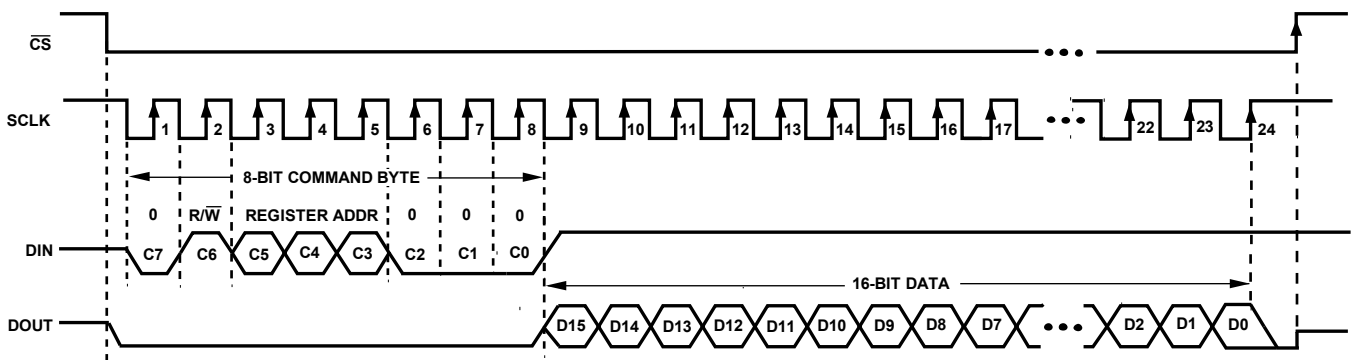

Figure 18. Reading from a 16-Bit Register

09012-031

READING DATA

A read transaction begins when the master writes the command byte to the ADT7320 with the read/write bit set to 1. The master then supplies 8 or 16 clock pulses, depending on the addressed register, and the ADT7320 clocks out data from the addressed register on the DOUT line. Data is clocked out on the first falling edge of SCLK following the command byte.

The read transaction finishes when the master pulls \overline{CS} high.

INTERFACING TO DSPs OR MICROCONTROLLERS

The ADT7320 can be operated with \overline{CS} used as a frame synchronization signal. This setup is useful for DSP interfaces. In this case, the first bit (MSB) is effectively clocked out by \overline{CS} because \overline{CS} normally occurs after the falling edge of SCLK in DSPs. SCLK can continue to run between data transfers, provided that the timing values are obeyed.

\overline{CS} can be tied to ground and the serial interface can operate in a 3-wire mode. DIN, DOUT, and SCLK are used to communicate with the ADT7320 in this mode.

For microcontroller interfaces, it is recommended that SCLK idle high between data transfers.

SERIAL INTERFACE RESET

The serial interface can be reset by writing a series of 1s on the DIN input. If a Logic 1 is written to the ADT7320 DIN line for at least 32 serial clock cycles, the serial interface is reset. This ensures that the interface can be reset to a known state if the interface is lost due to a software error or a glitch in the system. A reset returns the interface to the state in which it expects a write to a communications register. This operation resets the contents of all registers to their power-on values. Following a reset, allow a period of 500 μ s before addressing the serial interface.

INT AND CT OUTPUTS

The INT and CT pins are open-drain outputs, and both pins require a 10 kΩ pull-up resistor to V_{DD}. The ADT7320 must be fully powered up to V_{DD} before reading INT and CT data.

UNDERTEMPERATURE AND OVERTEMPERATURE DETECTION

The INT and CT pins have two undertemperature/overtemperature modes: comparator mode and interrupt mode. The interrupt mode is the default power-up overtemperature mode. The INT output pin becomes active when the temperature is greater than the temperature stored in the T_{HIGH} setpoint register or less than the temperature stored in the T_{LOW} setpoint register. How this pin reacts after an undertemperature or overtemperature event depends on the overtemperature mode selected.

Figure 19 illustrates the comparator and interrupt modes for events exceeding the T_{HIGH} limit with both pin polarity settings. Figure 20 illustrates the comparator and interrupt modes for events exceeding the T_{LOW} limit with both pin polarity settings.

Comparator Mode

In comparator mode, the INT pin returns to its inactive status when the temperature drops below the T_{HIGH} - T_{HYST} limit or rises above the T_{LOW} + T_{HYST} limit.

Placing the ADT7320 into shutdown mode does not reset the INT state in comparator mode.

Interrupt Mode

In interrupt mode, the INT pin returns to its inactive status when any ADT7320 register is read. When the INT pin is reset, it becomes active again only when the temperature is greater than the temperature stored in the T_{HIGH} setpoint register or less than the temperature stored in the T_{LOW} setpoint register.

Placing the ADT7320 into shutdown mode resets the INT pin in interrupt mode.

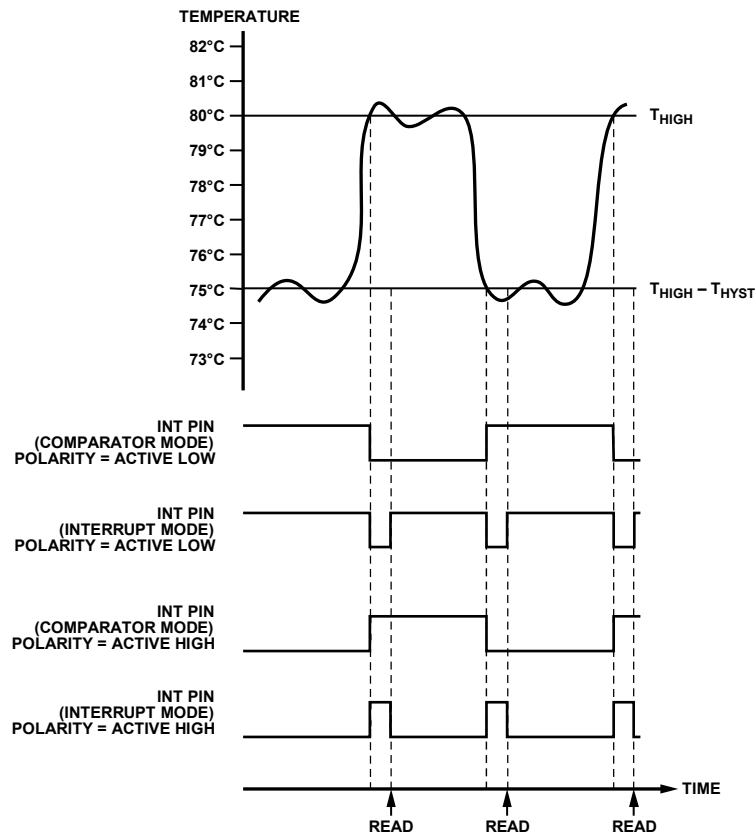

Figure 19. INT Output Temperature Response for T_{HIGH} Overtemperature Events

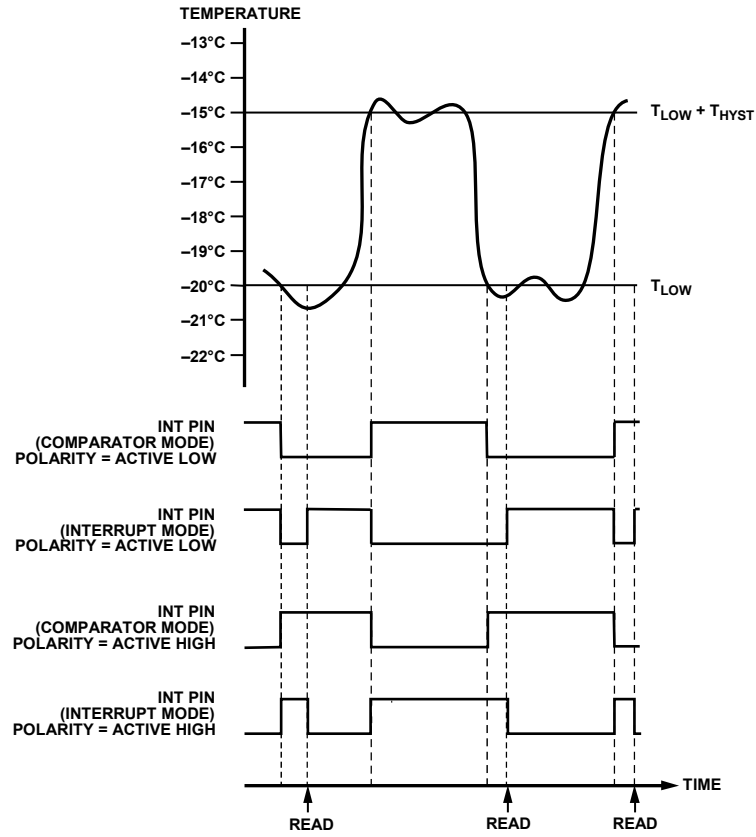

Figure 20. INT Output Temperature Response for T_{LOW} Undertemperature Events

09012-021

APPLICATIONS INFORMATION

THERMAL RESPONSE TIME

Thermal response is a function of the thermal mass of the temperature sensor, but it is also heavily influenced by the mass of the object that the IC is mounted to. For example, a large PCB containing large amounts of copper tracing can act as a large heat sink and slow the thermal response. For a faster thermal response, it is recommended that the sensor be mounted on a PCB that is as small as possible.

Figure 10 shows the typical response time of less than 2 seconds to reach 63.2% of the temperature span of the DUT. The temperature values are the digital bytes read back through the digital interface. The response time includes all delays incurred on chip during signal processing.

SUPPLY DECOUPLING

The ADT7320 must have a decoupling capacitor connected between V_{DD} and GND; otherwise, incorrect temperature readings will be obtained. A 0.1 μF decoupling capacitor, such as a high frequency ceramic type, must be used and mounted as close as possible to the V_{DD} pin of the ADT7320.

If possible, the ADT7320 should be powered directly from the system power supply. This arrangement, shown in Figure 21, isolates the analog section from the logic switching transients. Even if a separate power supply trace is not available, generous supply bypassing reduces supply line induced errors. Local supply bypassing consisting of a 0.1 μF ceramic capacitor is critical for the temperature accuracy specifications to be achieved.

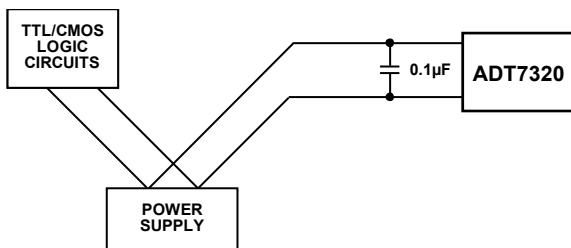

Figure 21. Use of Separate Traces to Reduce Power Supply Noise

09012-9022

POWERING FROM A SWITCHING REGULATOR

Precision analog devices such as the ADT7320 require a well-filtered power source. If the ADT7320 is powered from a switching regulator, noise may be generated above 50 kHz that may affect the temperature accuracy specifications. To prevent this, an RC filter should be used between the power supply and ADT7320 V_{DD} . The value of the components used should be carefully considered to ensure that the peak value of the supply noise is less than 1 mV. The RC filter should be mounted as far away as possible from the ADT7320 to ensure that the thermal mass is kept as low as possible.

TEMPERATURE MEASUREMENT

The ADT7320 accurately measures and converts the temperature at the surface of its own semiconductor chip. Thermal paths run through the leads, the exposed pad, as well as the plastic package. When the ADT7320 is used to measure the temperature of a nearby heat source, the thermal impedance between the heat source and the ADT7320 must be considered because this impedance affects the accuracy and thermal response of the measurement.

For air or surface temperature measurements, take care to isolate the package, leads, and exposed pad from ambient air temperature. Use of a thermally conductive adhesive can help to achieve a more accurate surface temperature measurement.

QUICK GUIDE TO MEASURING TEMPERATURE

The following is a quick guide for measuring temperature in continuous conversion mode (default power-up mode). Execute each step sequentially.

1. After power-up, reset the serial interface (load 32 consecutive 1s on DIN). This ensures all internal circuitry is properly initialized.
2. Verify the setup by reading the device ID (Register Address 0x03). It should read 0xC3.
3. After consistent consecutive readings are obtained from Step 2, read the configuration register (Register Address 0x01), T_{CRIT} (Register Address 0x04), T_{HIGH} (Register Address 0x06), and T_{LOW} (Register Address 0x07). Compare these values with the specified defaults in Table 6. If all the readings match, the interface is operational.
4. Write to the configuration register to set the ADT7320 to the desired configuration. Read the temperature value register. It should produce a valid temperature measurement.

OUTLINE DIMENSIONS

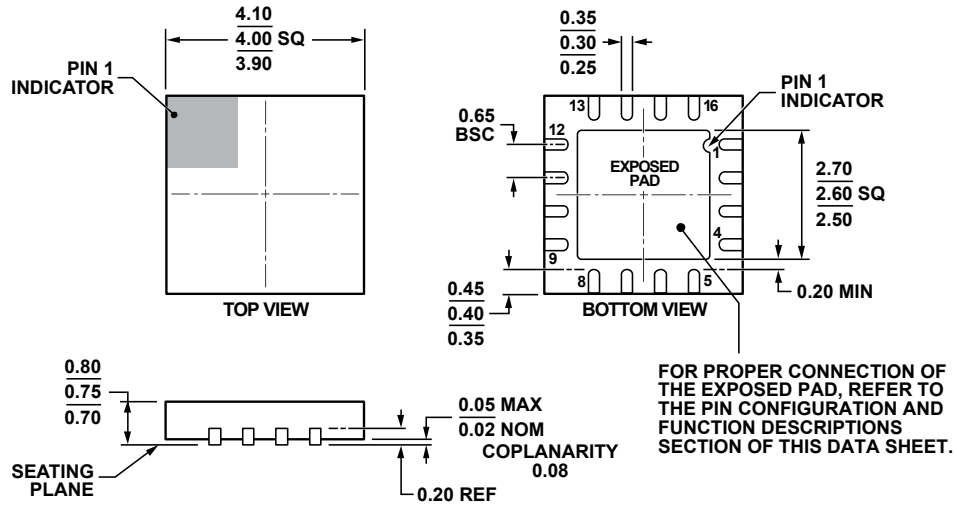

COMPLIANT TO JEDEC STANDARDS MO-220-WGGC.

Figure 22. 16-Lead Lead Frame Chip Scale Package [LFCSP_WQ]
 4 mm × 4 mm Body, Very Very Thin Quad
 (CP-16-17)
 Dimensions shown in millimeters

08-16-2010-C

ORDERING GUIDE

Model ¹	Temperature Range ²	Package Description	Package Option
ADT7320UCPZ-R2	-40°C to +150°C	16-lead LFCSP_WQ	CP-16-17
ADT7320UCPZ-RL7	-40°C to +150°C	16-Lead LFCSP_WQ	CP-16-17
EVAL-ADT7X20EBZ		Evaluation Board	

¹ Z = RoHS Compliant Part.

² Operating at extended temperatures over prolonged periods may shorten the lifetime performance of the part.

NOTES

Looking for pricing, stock, or lifecycle information?

Click below to explore more details on WIN SOURCE:

 [View ADT7320UCPZ-RL7 on WIN SOURCE](#)

 [Analog Devices Inc. Information](#)

Optimize Your Supply Chain with WIN SOURCE Solutions

-  Global Sourcing Solution
-  Obsolete Management
-  Cost Control Management
-  Shortage Management
-  Alternative Solution
-  Excess Inventory Management