



**THE DATASHEET OF
V2AF109A200Y2EDP**



TransFeed Automotive Series

AVX Multilayer Ceramic Transient Voltage Suppressors TVS Protection and EMI Attenuation in a Single Chip



GENERAL DESCRIPTION

AVX has combined the best electrical characteristics of its TransGuard® Transient Voltage Suppressors (TVS) and its Feedthru Capacitors into a single chip for state-of-the-art overvoltage circuit protection and EMI reduction over a broad range of frequencies. This unique combination of multilayer ceramic construction in a feedthru configuration gives the circuit designer a single 0805 chip that responds to transient events faster than any TVS device on the market today, and provides significant EMI attenuation when in the off-state.

Automotive TransFeeds are designed for automotive applications and are AEC-Q 200 qualified.

The reduction in parallel inductance, typical of the feedthru chip construction when compared to the construction of standard TVS or ceramic capacitor chips, gives the TransFeed product two very important electrical advantages: (1) faster “turn-on” time. Calculated response times of <200 pSec are not unusual with this device, and measured response times range from 200 – 250 pSec. The TransFeed “turn-on” characteristic is less than half that of an equivalent TransGuard® part — and TransGuards® clamp transient voltages faster than any other bipolar TVS solution such as diodes; (2) the second electrical advantage of lower parallel inductance, coupled with optimal series

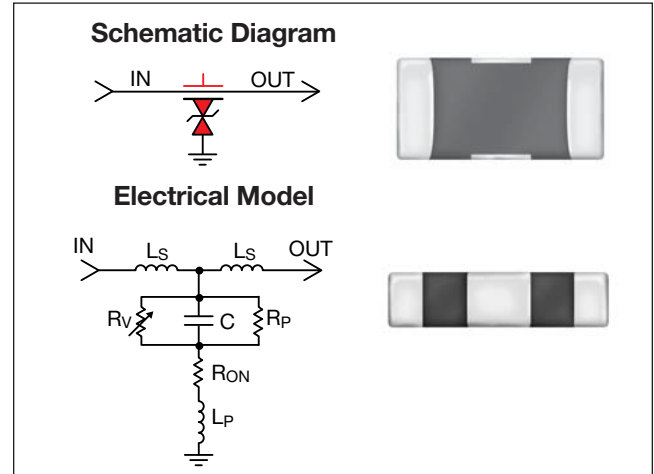

inductance, is the enhanced attenuation characteristics of the TransFeed product. Not only is there significantly greater attenuation at a higher self-resonance frequency, but the roll-off characteristic becomes much flatter, resulting in EMI filtering over a much broader frequency spectrum. Typical applications include filtering/protection on Microcontroller I/O Lines, Interface I/O Lines, Power Line Conditioning and Power Regulation.

TYPICAL APPLICATIONS

- Drive by Wire
- Dimming Mirror Circuit
- Filtering/protection on Microcontroller I/O lines
- Filtering/protection on Interface I/O lines
- Power Line Conditioning
- Power Regulation
- LCD Dashboard driver

Where designers are concerned with both transient voltage protection and EMI attenuation, either due to the electrical performance of their circuits or due to required compliance to specific EMC regulations, the TransFeed product is an ideal choice.

GENERAL CHARACTERISTICS

- Operating Temperature: -55°C to +125°C
- Working Voltage: 5.6Vdc - 26Vdc
- Case Size: 0805
- Energy Rating: 0.05 - 0.3J
- Current: 20 - 120A
- Max Feedthru Current: 0.5 - 1A

FEATURES

- Bi-directional TVS
- Narrow band, high attenuation filter
- EMI Filtering over broader frequency range
- Fastest Response Time to ESD Strikes
- AEC-Q 200 Qualified

TransFeed Automotive Series

AVX Multilayer Ceramic Transient Voltage Suppressors

TVS Protection and EMI Attenuation in a Single Chip



HOW TO ORDER

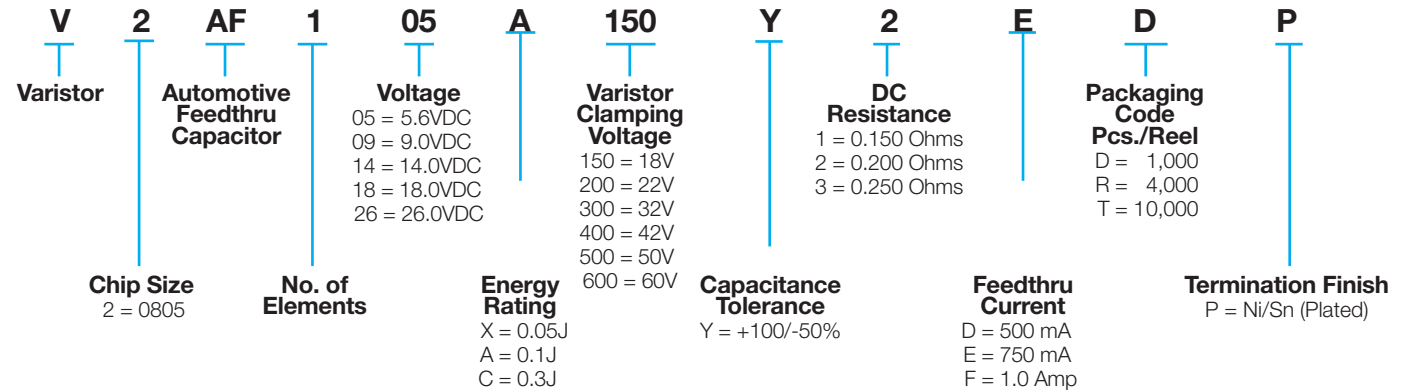

TRANSFEED ELECTRICAL SPECIFICATIONS

AVX Part Number	Working Voltage (DC)	Working Voltage (AC)	Breakdown Voltage	Clamping Voltage	Maximum Leakage Current	Transient Energy Rating	Peak Current Rating	Typical Cap	DC Resistance	Maximum Feedthru Current	Jump Start Voltage
V2AF105A150Y2E__	5.6	4.0	8.5±20%	18	35	0.10	30	800	0.200	0.75	-
V2AF105C150Y1F__	5.6	4.0	8.5±20%	18	35	0.30	120	2500	0.150	1.00	-
V2AF109A200Y2E__	9.0	6.4	12.7±15%	22	25	0.10	30	575	0.200	0.75	-
V2AF109C200Y1F__	9.0	6.4	12.7±15%	22	25	0.30	120	1800	0.150	1.00	-
V2AF114A300Y2E__	14.0	10.0	18.5±12%	32	15	0.10	30	300	0.200	0.75	27.5
V2AF114C300Y1F__	14.0	10.0	18.5±12%	32	15	0.30	120	900	0.150	1.00	27.5
V2AF118A400Y2E__	18.0	13.0	25.5±10%	42	10	0.10	30	200	0.200	0.75	27.5
V2AF118C400Y1F__	18.0	13.0	25.5±10%	42	10	0.30	120	500	0.150	1.00	27.5
V2AF118X500Y3D__	18.0	13.0	25.5±10%	50	10	0.05	20	75	0.250	0.50	27.5
V2AF126C600Y2E__	26.0	18.0	34.5±10%	60	10	0.3	80	250	0.2	0.75	27.5

Termination Finish Code
Packaging Code

V_w (DC)	DC Working Voltage (V)	E_T	Transient Energy Rating (J, 10x1000µS)
V_w (AC)	AC Working Voltage (V)	I_p	Peak Current Rating (A, 8x20µS)
V_B	Typical Breakdown Voltage (V @ 1mA _{DC})	Cap	Typical Capacitance (pF) @ 1MHz and 0.5 V
V_B Tol	V_B Tolerance is ± from Typical Value	DCR	DC Resistance (Ohms)
V_C	Clamping Voltage (V @ 1A 8x20µS)	I_{FT}	Maximum Feedthru Current (A)
I_L	Maximum Leakage Current at the Working Voltage (µA)	V_{JUMP}	Jump Start Voltage (V, 5 min)

TransFeed Automotive Series

AVX Multilayer Ceramic Transient Voltage Suppressors

TVS Protection and EMI Attenuation in a Single Chip



DIMENSIONS

	L	W	T	BW	BL	EW	X	S	mm (inches)
0805	2.01 ± 0.20 (0.079 ± 0.008)	1.25 ± 0.20 (0.049 ± 0.008)	1.143 Max. (0.045 Max.)	0.46 ± 0.10 (0.018 ± 0.004)	0.18 + 0.25 - 0.08 (0.007 + 0.010 - 0.003)	0.25 ± 0.13 (0.010 ± 0.005)	1.02 ± 0.10 (0.040 ± 0.004)	0.23 ± 0.05 (0.009 ± 0.002)	

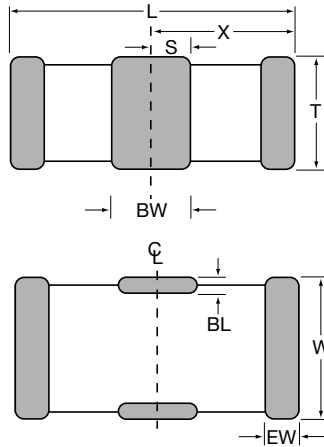

RECOMMENDED SOLDER PAD LAYOUT (Typical Dimensions)

	T	P	S	W	L	C	mm (inches)
0805	3.45 (0.136)	0.51 (0.020)	0.76 (0.030)	1.27 (0.050)	1.02 (0.040)	0.46 (0.018)	

4 Pad Layout

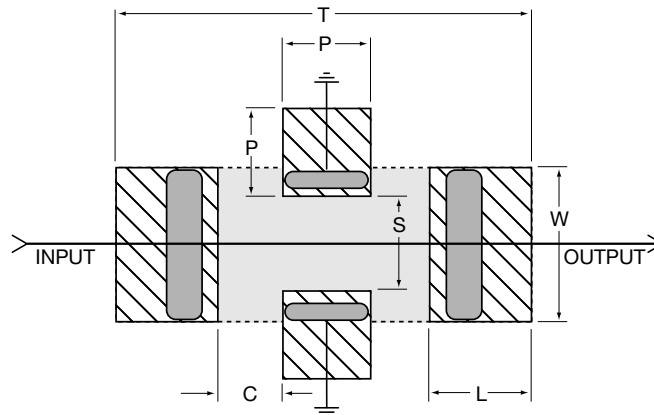

TransFeed Automotive Series

AVX Multilayer Ceramic Transient Voltage Suppressors

TVS Protection and EMI Attenuation in a Single Chip



PERFORMANCE CHARACTERISTICS

FEEDTHRU VARISTORS

AVX Multilayer Feedthru Varistors (MLVF) are an ideal choice for system designers with transient strike and broadband EMI/RFI concerns.

Feedthru Varistors utilize a ZnO varistor material and the electrode pattern of a feedthru capacitor. This combination allows the package advantage of the feedthru and material advantages of the ZnO dielectric to be optimized.

ZnO MLV Feedthrus exhibit electrical and physical advantages over standard ZnO MLVs. Among them are:

1. Faster Turn on Time
2. Broadband EMI attenuation
3. Small size (relative to discrete MLV and EMI filter schemes)

The electrical model for a ZnO MLV and a ZnO Feedthru MLV are shown below. The key difference in the model for the Feedthru is a transformation in parallel to series inductance. The added series inductance helps lower the injected transient peak current (by $2\pi fL$) resulting in an additional benefit of a lower clamping voltage. The lowered parallel inductance decreases the turn on time for the varistor to <250ps.

Discrete MLV Model

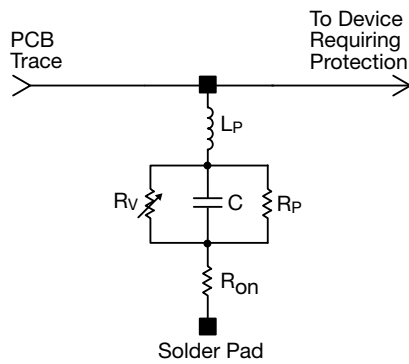

Where: R_v = Voltage Variable resistance (per VI curve)
 $R_p \geq 10^{12} \Omega$
 C = defined by voltage rating and energy level
 R_{on} = turn on resistance
 L_p = parallel body inductance

Discrete MLVF Model

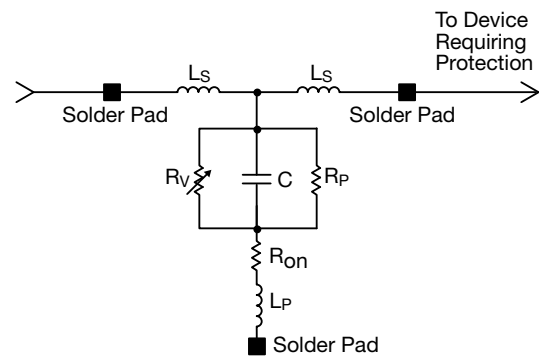

Where: R_v = Voltage Variable resistance (per VI curve)
 R_p = Body IR
 C = defined by voltage rating and energy level
 R_{on} = turn on resistance
 L_p = minimized parallel body inductance
 L_s = series body inductance

TransFeed Automotive Series

AVX Multilayer Ceramic Transient Voltage Suppressors TVS Protection and EMI Attenuation in a Single Chip



PERFORMANCE CHARACTERISTICS

APPLICATIONS

- EMI Suppression
- Broadband I/O Filtering
- Vcc Line Conditioning

FEATURES

- Small Size
- Low ESR
- Ultra-fast Response Time
- Broad S21 Characteristics

MARKET SEGMENTS

- Computers
- Automotive
- Power Supplies
- Multimedia Add-On Cards
- Bar Code Scanners
- Remote Terminals
- Medical Instrumentation
- Test Equipment
- Transceivers
- Cellular Phones / Pagers

TYPICAL CIRCUITS REQUIRING TRANSIENT VOLTAGE PROTECTION AND EMI FILTERING

The following applications and schematic diagrams show where TransFeed TVS/ EMI filtering devices might be used:

- System Board Level Interfaces: (Fig. 1)
Digital to RF
Analog to Digital
Digital to Analog
- Voltage Regulation (Fig. 2)
- Power Conversion Circuits (Fig. 3)
- GaAs FET Protection (Fig. 4)

Fig. 1 – System Interface

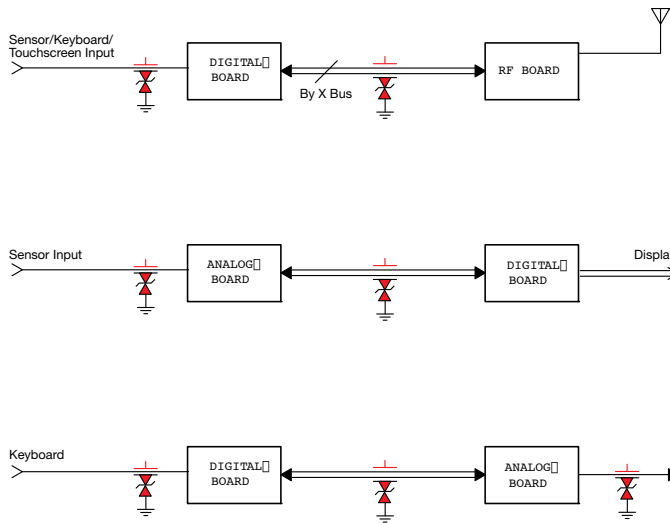

Fig. 2 – Voltage Regulators

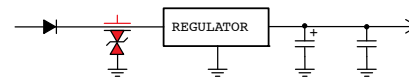

Fig. 3 – Power Conversion Circuits/Power Switching Circuits

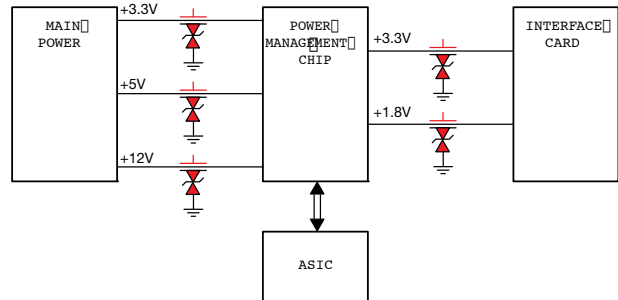

Fig. 4 – GaAs FET Protection

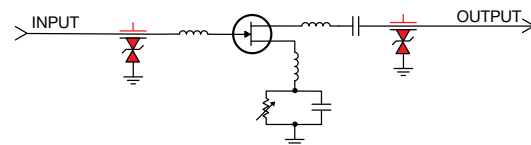
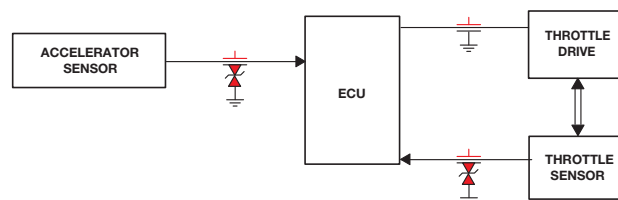

Fig. 5 – Automotive TransFeed - Throttle by Wire



SPECIFICATION COMPARISON

MLVF 0805	PARAMETER	MLV 0805
5ph	L_s typical	N/A
<600nh	L_p typical	<1.5nh
<0.025 Ω	R_{on} typical	<0.1 Ω
100pf to 2.5nf	C typical	100pf to 5.5nf
see VI curves	R_v typical	see VI curves
>0.25 x 10 ¹² Ω	R_p typical	>1 x 10 ¹² Ω
<250ps	Typical turn on time Typical frequency response	<500ps

A comparison table showing typical element parameters and resulting performance features for MLV and MLVF is shown above.

Looking for pricing, stock, or lifecycle information?

Click below to explore more details on WIN SOURCE:

- ⊖ [View V2AF109A200Y2EDP on WIN SOURCE](#)
- ⊖ [AVX Corporation Information](#)

Optimize Your Supply Chain with WIN SOURCE Solutions

- ✓ Global Sourcing Solution
- ✓ Obsolete Management
- ✓ Cost Control Management
- ✓ Shortage Management
- ✓ Alternative Solution
- ✓ Excess Inventory Management