



**THE DATASHEET OF
AFT20S015GNR1**





RF Power LDMOS Transistors

N-Channel Enhancement-Mode Lateral MOSFETs

These 1.5 W RF power LDMOS transistors are designed for cellular base station applications covering the frequency range of 1805 to 2700 MHz.

2100 MHz

- Typical Single-Carrier W-CDMA Performance: $V_{DD} = 28$ Vdc, $I_{DQ} = 132$ mA, $P_{out} = 1.5$ W Avg., Input Signal PAR = 9.9 dB @ 0.01% Probability on CCDF.

Frequency	G_{ps} (dB)	η_D (%)	Output PAR (dB)	ACPR (dBc)	IRL (dB)
2110 MHz	17.5	22.0	8.9	-43.0	-11
2140 MHz	17.6	22.0	9.0	-44.0	-12
2170 MHz	17.6	22.0	9.1	-44.0	-14

1800 MHz

- Typical Single-Carrier W-CDMA Performance: $V_{DD} = 28$ Vdc, $I_{DQ} = 132$ mA, $P_{out} = 1.5$ W Avg., Input Signal PAR = 9.9 dB @ 0.01% Probability on CCDF.

Frequency	G_{ps} (dB)	η_D (%)	Output PAR (dB)	ACPR (dBc)	IRL (dB)
1805 MHz	18.0	21.0	9.2	-42.0	-11
1840 MHz	18.1	22.0	9.2	-44.0	-10
1880 MHz	18.0	22.0	9.1	-45.0	-10

2600 MHz

- Typical Single-Carrier W-CDMA Performance: $V_{DD} = 28$ Vdc, $I_{DQ} = 132$ mA, $P_{out} = 2.1$ W Avg., Input Signal PAR = 9.9 dB @ 0.01% Probability on CCDF.

Frequency	G_{ps} (dB)	η_D (%)	Output PAR (dB)	ACPR (dBc)	IRL (dB)
2300 MHz	15.7	23.0	9.0	-45.0	-6
2400 MHz	16.0	23.0	8.8	-44.0	-7
2500 MHz	15.8	23.0	8.6	-43.0	-6
2600 MHz	15.8	21.0	8.5	-43.0	-7
2700 MHz	15.5	20.0	8.4	-42.0	-8

Features

- Greater Negative Gate-Source Voltage Range for Improved Class C Operation
- Designed for Digital Predistortion Error Correction Systems
- Optimized for Doherty Applications
- In Tape and Reel. R1 Suffix = 500 Units, 24 mm Tape Width, 13-inch Reel.

AFT20S015NR1
AFT20S015GNR1

1805–2700 MHz, 1.5 W AVG., 28 V
AIRFAST RF POWER LDMOS
TRANSISTORS

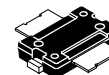

TO-270-2
PLASTIC
AFT20S015NR1

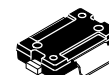

TO-270-2 GULL
PLASTIC
AFT20S015GNR1

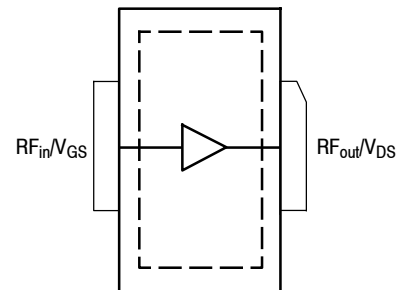

(Top View)

Note: The backside of the package is the source terminal for the transistor.

Figure 1. Pin Connections

Table 1. Maximum Ratings

Rating	Symbol	Value	Unit
Drain-Source Voltage	V_{DSS}	-0.5, +65	Vdc
Gate-Source Voltage	V_{GS}	-6.0, +10	Vdc
Operating Voltage	V_{DD}	32, +0	Vdc
Storage Temperature Range	T_{stg}	-65 to +150	°C
Case Operating Temperature Range	T_C	-40 to +150	°C
Operating Junction Temperature Range (1,2)	T_J	-40 to +225	°C
CW Operation @ $T_C = 25^\circ\text{C}$ Derate above 25°C	CW	11 0.1	W W/°C

Table 2. Thermal Characteristics

Characteristic	Symbol	Value (2,3)	Unit
Thermal Resistance, Junction to Case Case Temperature 77°C, 1.5 W CW, 28 Vdc, $I_{DQ} = 132$ mA, 2140 MHz	$R_{\theta JC}$	4.2	°C/W

Table 3. ESD Protection Characteristics

Test Methodology	Class
Human Body Model (per JESD22-A114)	1C
Machine Model (per EIA/JESD22-A115)	A
Charge Device Model (per JESD22-C101)	IV

Table 4. Moisture Sensitivity Level

Test Methodology	Rating	Package Peak Temperature	Unit
Per JESD22-A113, IPC/JEDEC J-STD-020	3	260	°C

Table 5. Electrical Characteristics ($T_A = 25^\circ\text{C}$ unless otherwise noted)

Characteristic	Symbol	Min	Typ	Max	Unit
----------------	--------	-----	-----	-----	------

Off Characteristics

Zero Gate Voltage Drain Leakage Current ($V_{DS} = 65$ Vdc, $V_{GS} = 0$ Vdc)	I_{DSS}	—	—	10	μAdc
Zero Gate Voltage Drain Leakage Current ($V_{DS} = 28$ Vdc, $V_{GS} = 0$ Vdc)	I_{DSS}	—	—	1	μAdc
Gate-Source Leakage Current ($V_{GS} = 5$ Vdc, $V_{DS} = 0$ Vdc)	I_{GSS}	—	—	1	μAdc

On Characteristics

Gate Threshold Voltage ($V_{DS} = 10$ Vdc, $I_D = 17.6$ μAdc)	$V_{GS(th)}$	1.5	2.0	2.5	Vdc
Gate Quiescent Voltage ($V_{DD} = 28$ Vdc, $I_D = 132$ mA, Measured in Functional Test)	$V_{GS(Q)}$	2.4	3.0	3.4	Vdc
Drain-Source On-Voltage ($V_{GS} = 10$ Vdc, $I_D = 176$ Adc)	$V_{DS(on)}$	0.1	0.2	0.3	Vdc

1. Continuous use at maximum temperature will affect MTTF.
2. MTTF calculator available at <http://www.freescale.com/rf>. Select Software & Tools/Development Tools/Calculators to access MTTF calculators by product.
3. Refer to AN1955, *Thermal Measurement Methodology of RF Power Amplifiers*. Go to <http://www.freescale.com/rf>. Select Documentation/Application Notes - AN1955.

(continued)

Table 5. Electrical Characteristics ($T_A = 25^\circ\text{C}$ unless otherwise noted) (continued)

Characteristic	Symbol	Min	Typ	Max	Unit
Functional Tests ^(1,2) (In Freescale Test Fixture, 50 ohm system) $V_{DD} = 28\text{ Vdc}$, $I_{DQ} = 132\text{ mA}$, $P_{out} = 1.5\text{ W Avg.}$, $f = 2170\text{ MHz}$, Single-Carrier W-CDMA, IQ Magnitude Clipping, Input Signal PAR = 9.9 dB @ 0.01% Probability on CCDF. ACPR measured in 3.84 MHz Channel Bandwidth @ $\pm 5\text{ MHz}$ Offset.					
Power Gain	G_{ps}	16.0	17.6	19.0	dB
Drain Efficiency	η_D	20.0	22.0	—	%
Output Peak-to-Average Ratio @ 0.01% Probability on CCDF	PAR	8.6	9.1	—	dB
Adjacent Channel Power Ratio	ACPR	—	-44.0	-41.0	dBc
Input Return Loss	IRL	—	-14	-9	dB

Load Mismatch (In Freescale Test Fixture, 50 ohm system) $I_{DQ} = 132\text{ mA}$, $f = 2140\text{ MHz}$

VSWR 10:1 at 32 Vdc, 14 W CW ⁽³⁾ Output Power (3 dB Input Overdrive from 12 W CW ⁽³⁾ Rated Power)	No Device Degradation
--	-----------------------

Typical Performance (In Freescale Test Fixture, 50 ohm system) $V_{DD} = 28\text{ Vdc}$, $I_{DQ} = 132\text{ mA}$, 2110-2170 MHz Bandwidth

P_{out} @ 1 dB Compression Point, CW	P1dB	—	16.2 ^(3,4)	—	W
AM/PM (Maximum value measured at the P3dB compression point across the 2110-2170 MHz frequency range.)	Φ	—	-16	—	°
VBW Resonance Point (IMD Third Order Intermodulation Inflection Point)	VBW_{res}	—	170	—	MHz
Gain Flatness in 60 MHz Bandwidth @ $P_{out} = 1.5\text{ W Avg.}$	G_F	—	0.05	—	dB
Gain Variation over Temperature (-30°C to $+85^\circ\text{C}$)	ΔG	—	0.01	—	dB/°C
Output Power Variation over Temperature (-30°C to $+85^\circ\text{C}$) ⁽³⁾	$\Delta P1dB$	—	0.004	—	dB/°C

1. Part internally matched on input.
2. Measurements made with device in straight lead configuration, before any lead forming operation is applied. Lead forming is used for gull wing (GN) parts.
3. Exceeds recommended operating conditions. See CW operation data in Maximum Ratings table.
4. Calculated from load pull P3dB measurements.

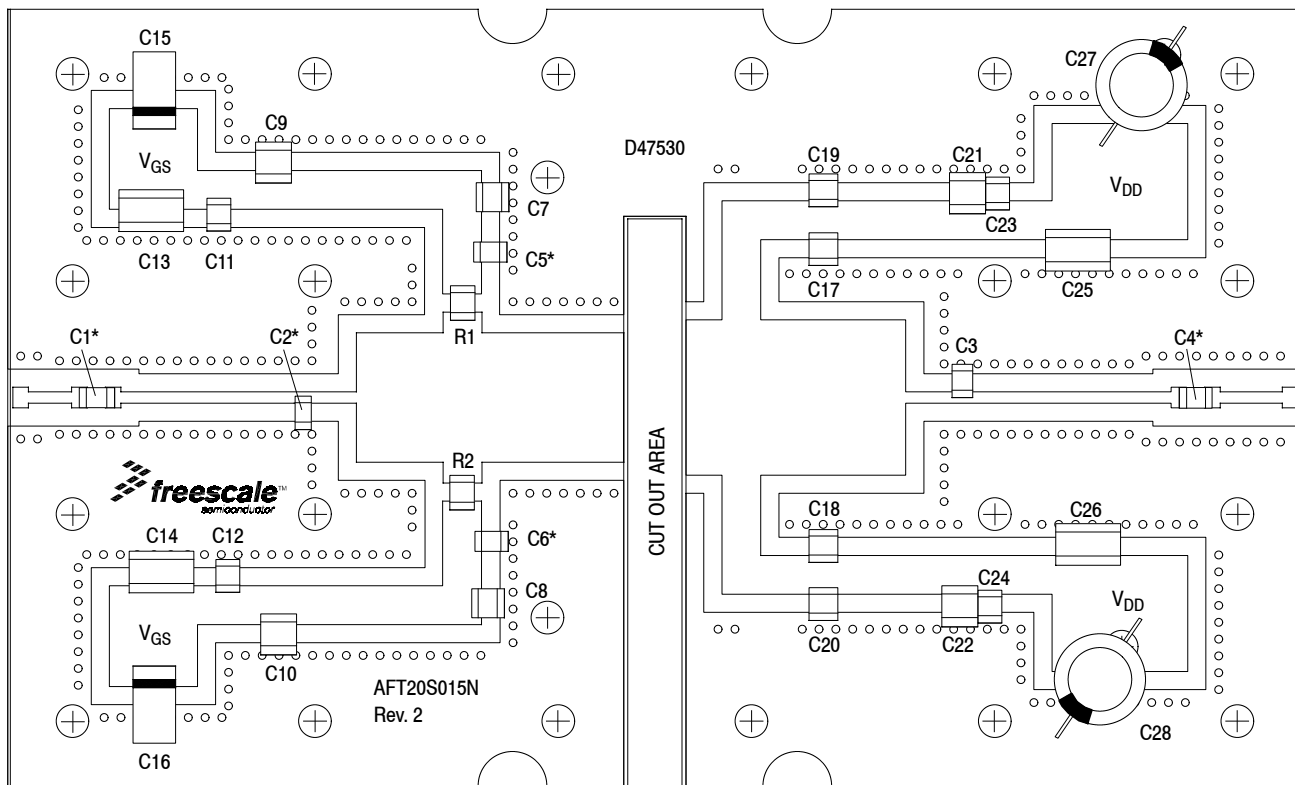

*C1, C2, C4, C5 and C6 are mounted vertically.

Figure 2. AFT20S015NR1 Test Circuit Component Layout — 2110-2170 MHz

Table 6. AFT20S015NR1 Test Circuit Component Designations and Values — 2110-2170 MHz

Part	Description	Part Number	Manufacturer
C1	8.2 pF Chip Capacitor	ATC100B8R2CT500XT	ATC
C2	2.4 pF Chip Capacitor	ATC800B2R4BT500XT	ATC
C3	1.7 pF Chip Capacitor	ATC100B1R7BT500XT	ATC
C4	9.1 pF Chip Capacitor	ATC100B9R1CT500XT	ATC
C5, C6	6.8 pF Chip Capacitors	ATC100B6R8CT500XT	ATC
C7, C8	240 pF Chip Capacitors	ATC100B241JT200XT	ATC
C9, C10, C21, C22	220 pF Chip Capacitors	C1812C224K5RAC-TU	Kemet
C11, C12, C23, C24	0.1 μ F Chip Capacitors	CDR33BX104AKWS	AVX
C13, C14, C25, C26	2.2 μ F Chip Capacitors	C1825C225J5RAC-TU	Kemet
C15, C16	22 μ F, 35 V Tantalum Capacitors	T491X226K035AT	Kemet
C17, C18, C19, C20	75 pF Chip Capacitors	ATC800B750JT500XT	ATC
C27, C28	470 μ F, 63 V Electrolytic Capacitors	MCGPR63V477M13X26-RH	Multicomp
R1, R2	1 Ω Chip Resistors	CRCW12061R00FKEA	Vishay
PCB	Rogers RO4350B, 0.020", $\epsilon_r = 3.66$	D47530	MTL

TYPICAL CHARACTERISTICS — 2110-2170 MHz

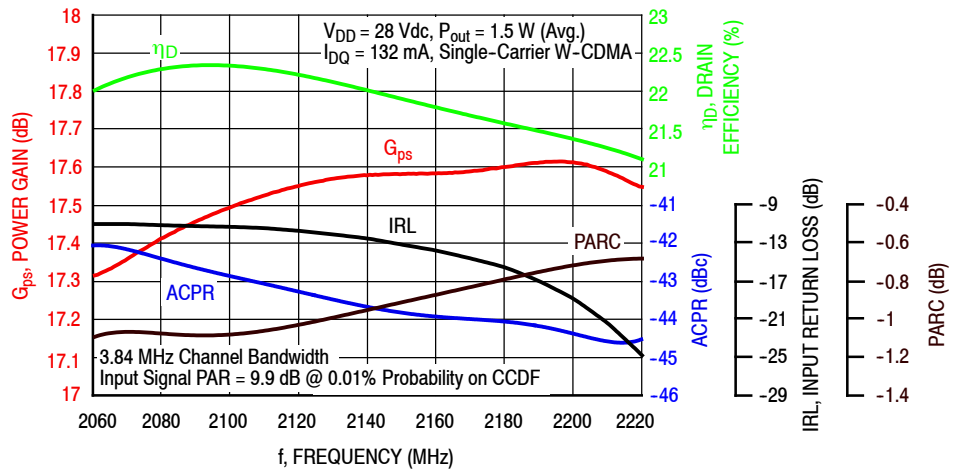

Figure 3. Single-Carrier Output Peak-to-Average Ratio Compression (PARC) Broadband Performance @ $P_{out} = 1.5$ Watts Avg.

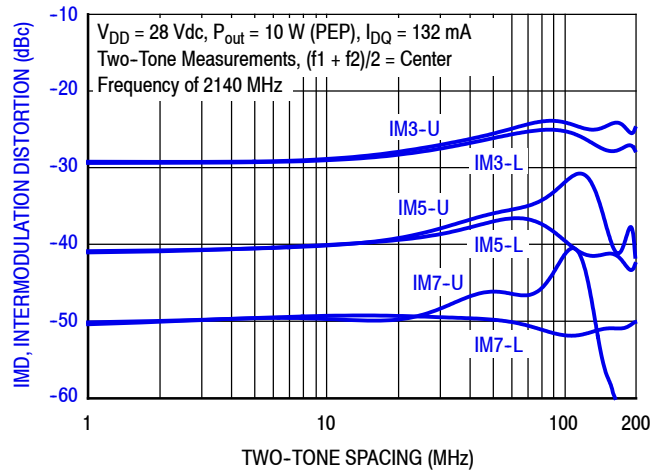

Figure 4. Intermodulation Distortion Products versus Two-Tone Spacing

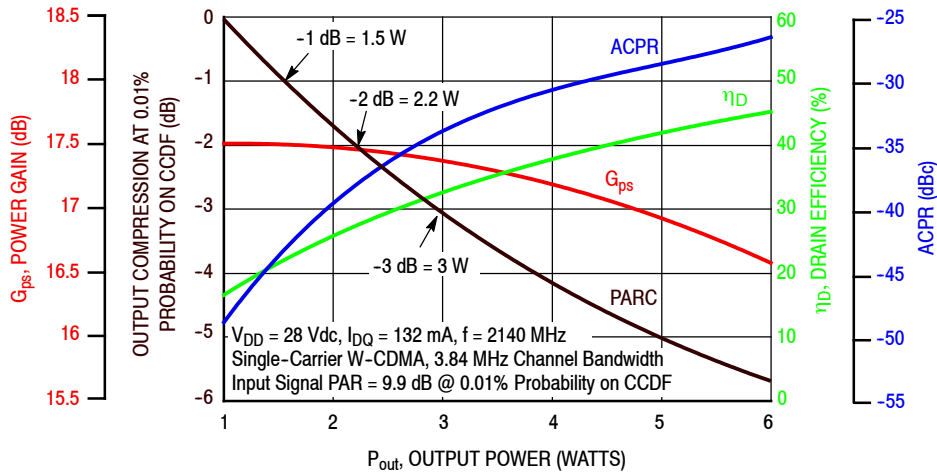

Figure 5. Output Peak-to-Average Ratio Compression (PARC) versus Output Power

TYPICAL CHARACTERISTICS — 2110-2170 MHz

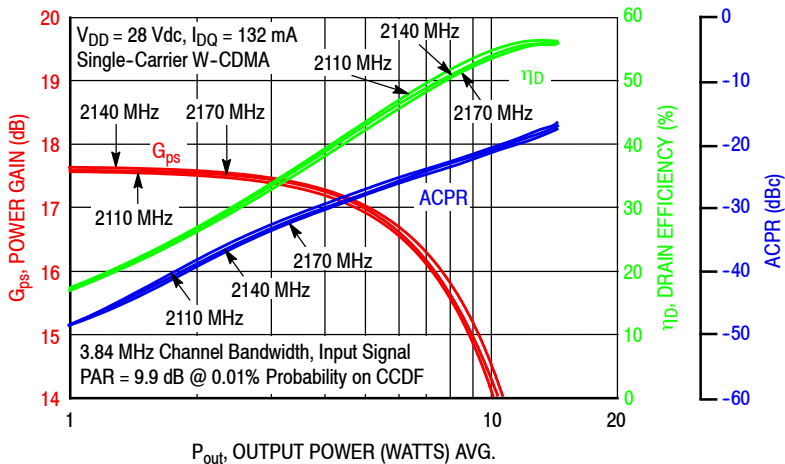

Figure 6. Single-Carrier W-CDMA Power Gain, Drain Efficiency and ACPR versus Output Power

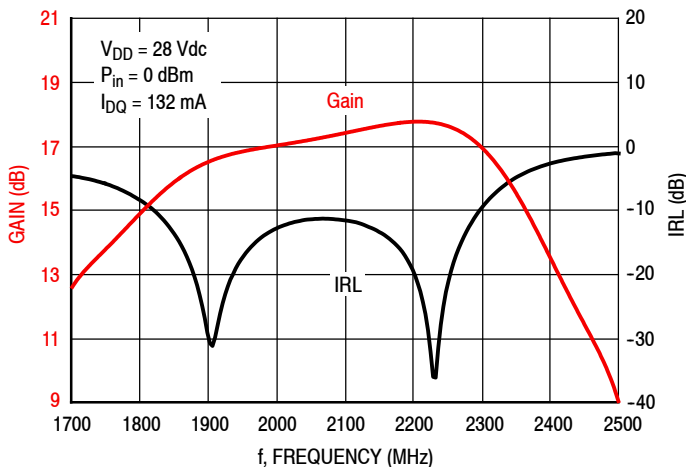
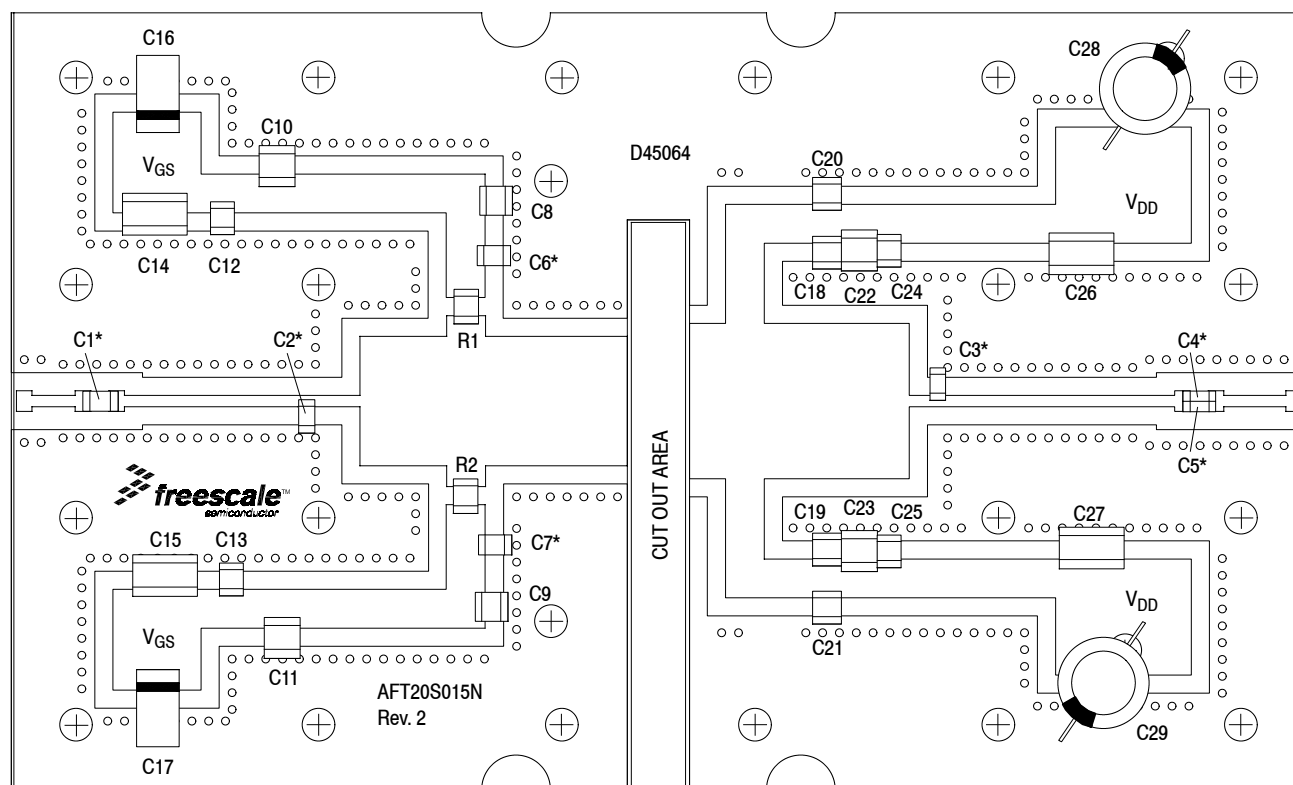

Figure 7. Broadband Frequency Response

ALTERNATE CHARACTERIZATION — 1805-1880 MHz



*C1, C2, C3, C4, C5, C6 and C7 are mounted vertically.

Figure 8. AFT20S015NR1 Test Circuit Component Layout — 1805-1880 MHz

Table 7. AFT20S015NR1 Test Circuit Component Designations and Values — 1805-1880 MHz

Part	Description	Part Number	Manufacturer
C1	11 pF Chip Capacitor	ATC100B11R0CT500XT	ATC
C2, C3	3.3 pF Chip Capacitors	ATC800B3R3BT500XT	ATC
C4, C5	47 pF Chip Capacitors	ATC600F47BT250XT	ATC
C6, C7	6.8 pF Chip Capacitors	ATC100B6R8CT500XT	ATC
C8, C9	240 pF Chip Capacitors	ATC100B241JT200XT	ATC
C10, C11, C22, C23	220 pF Chip Capacitors	C1812C224K5RAC-TU	Kemet
C12, C13, C24, C25	0.1 μ F Chip Capacitors	CDR33BX104AKWS	AVX
C14, C15, C26, C27	2.2 μ F, 50 V Chip Capacitors	C1825C225J5RAC-TU	Kemet
C16, C17	22 μ F, 35 V Tantalum Capacitors	T491X226K035AT	Kemet
C18, C19, C20, C21	75 pF Chip Capacitors	ATC800B750JT500XT	ATC
C28, C29	470 μ F, 63 V Electrolytic Capacitors	MCGPR63V477M13X26-RH	Multicomp
R1, R2	1 Ω Chip Resistors	CRCW12061R00FKEA	Vishay
PCB	Rogers RO4350B, 0.020", $\epsilon_r = 3.66$	D45064	MTL

ALTERNATE CHARACTERIZATION — 1805-1880 MHz

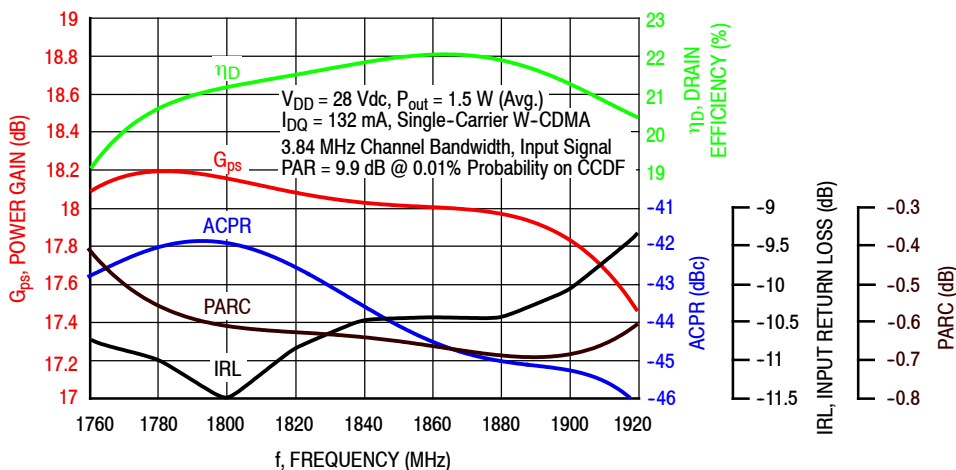

Figure 9. Single-Carrier Output Peak-to-Average Ratio Compression (PARC) Broadband Performance @ $P_{out} = 1.5$ Watts Avg.

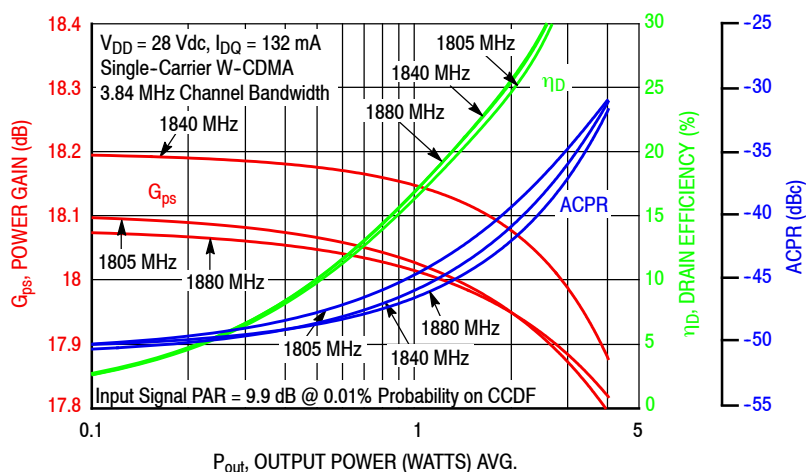

Figure 10. Single-Carrier W-CDMA Power Gain, Drain Efficiency and ACPR versus Output Power

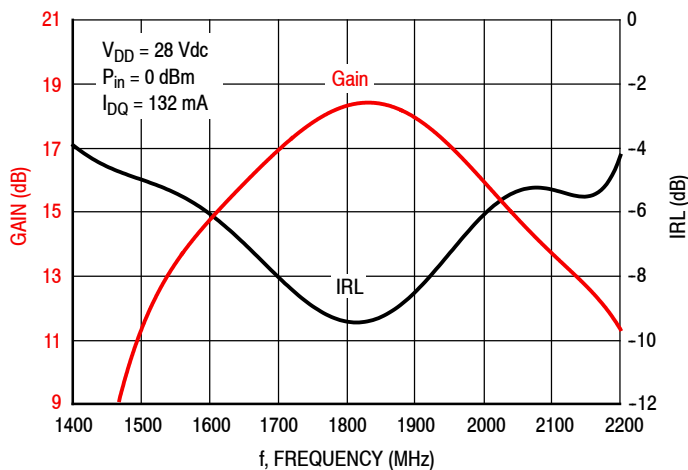
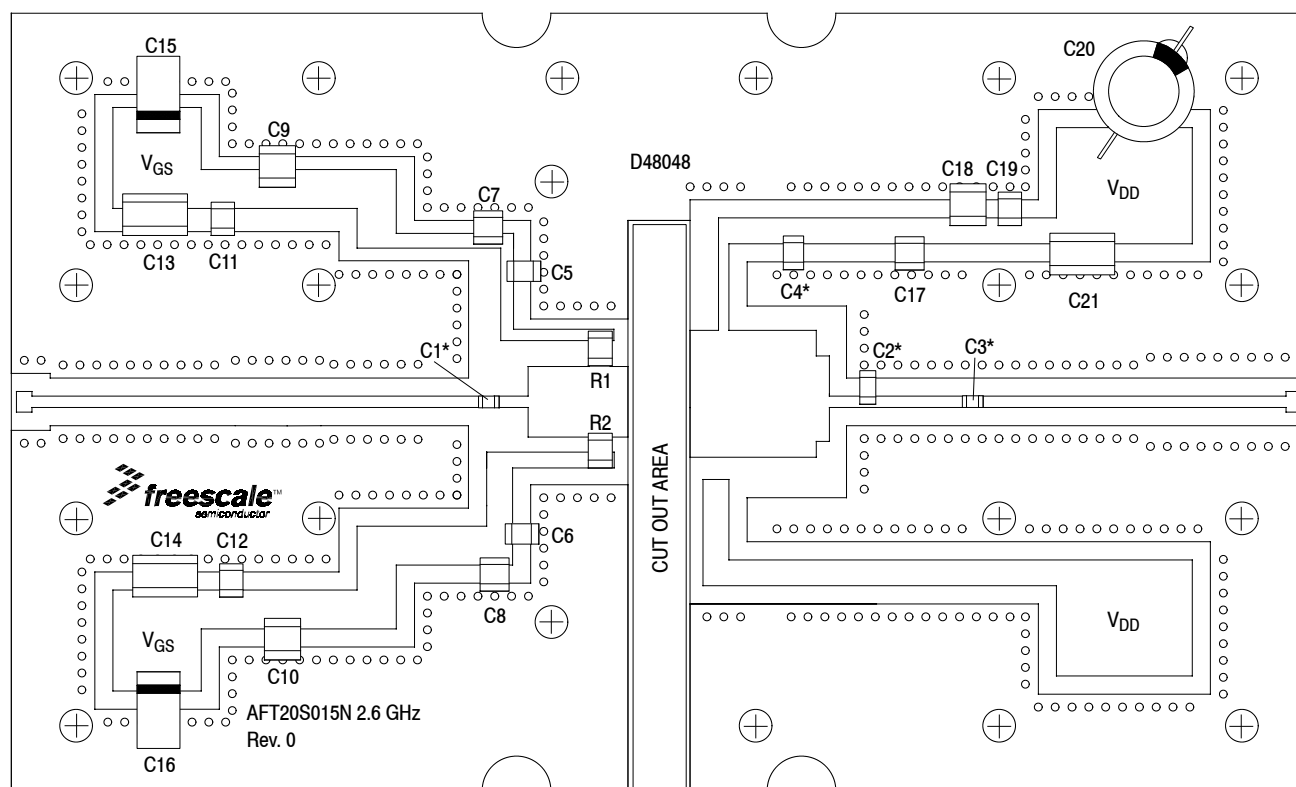

Figure 11. Broadband Frequency Response

ALTERNATE CHARACTERIZATION — 2300-2700 MHz



*C1, C2, C3 and C4 are mounted vertically.

Figure 12. AFT20S015NR1 Test Circuit Component Layout — 2300-2700 MHz

Table 8. AFT20S015NR1 Test Circuit Component Designations and Values — 2300-2700 MHz

Part	Description	Part Number	Manufacturer
C1	4.3 pF Chip Capacitor	ATC600F4R3CT250XT	ATC
C2	1.3 pF Chip Capacitor	ATC800B1R3BT500XT	ATC
C3	8.2 pF Chip Capacitor	ATC600F8R2BT250XT	ATC
C4	6.8 pF Chip Capacitor	ATC100B6R8CT500XT	ATC
C5, C6	6.8 pF Chip Capacitors	ATC800B6R8CT500XT	ATC
C7, C8, C17	2.2 μ F Chip Capacitors	C3225X7R1H225KT	TDK
C9, C10, C18	220 nF Chip Capacitors	C1812C224K5RAC-TU	Kemet
C11, C12, C19	0.1 μ F Chip Capacitors	CDR33BX104AKWS	AVX
C13, C14, C21	2.2 μ F Chip Capacitors	C1825C225J5RAC-TU	Kemet
C15, C16	22 μ F, 35 V Tantalum Capacitors	T491X226K035AT	Kemet
C20	470 μ F, 63 V Electrolytic Capacitor	MCGPR63V477M13X26-RH	Multicomp
R1, R2	4.75 Ω Chip Resistors	CRCW12064R75FKEA	Vishay
PCB	Rogers RO4350B, 0.020", $\epsilon_r = 3.66$	D48048	MTL

ALTERNATE CHARACTERIZATION — 2300-2700 MHz

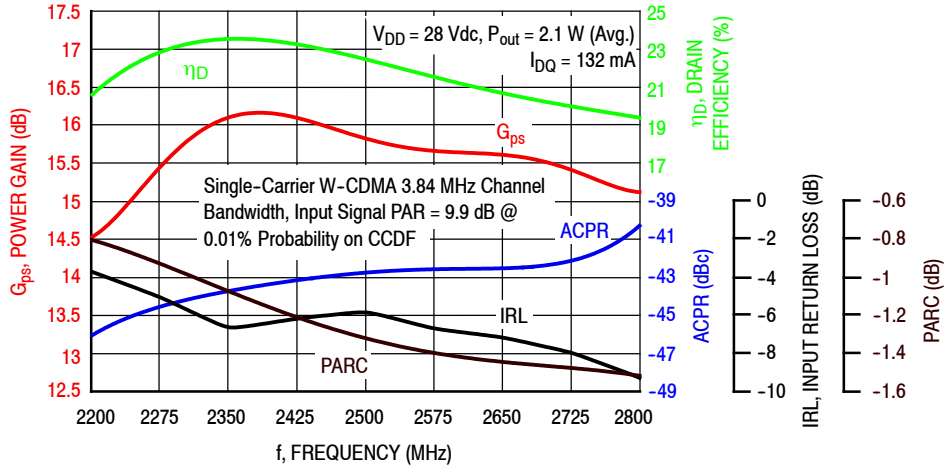

Figure 13. Single-Carrier Output Peak-to-Average Ratio Compression (PARC) Broadband Performance @ $P_{out} = 2.1$ Watts Avg.

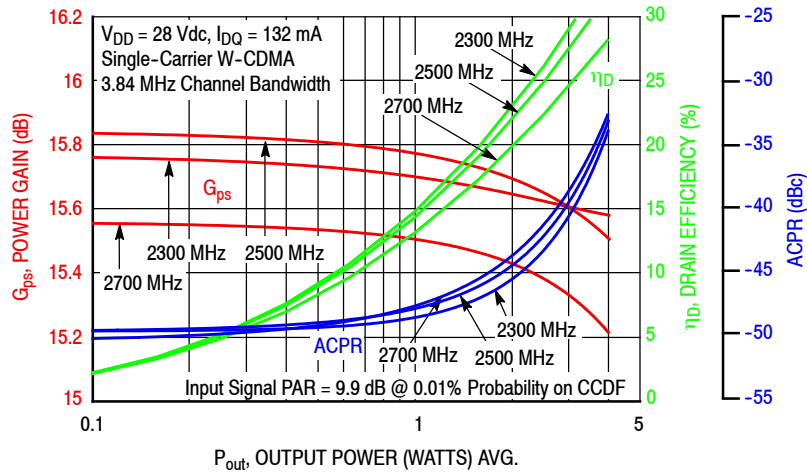

Figure 14. Single-Carrier W-CDMA Power Gain, Drain Efficiency and ACPR versus Output Power

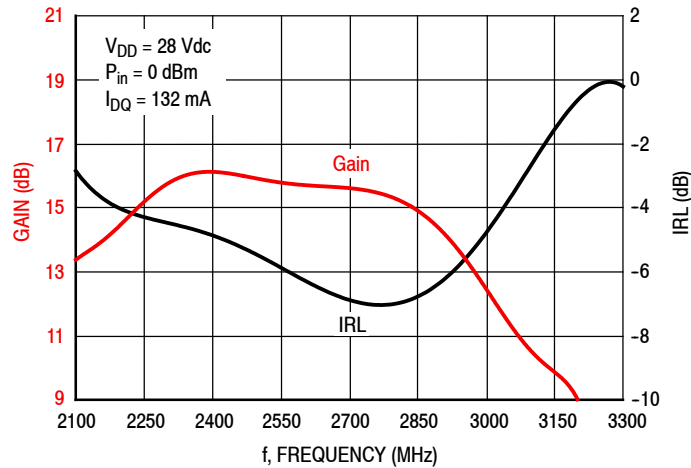
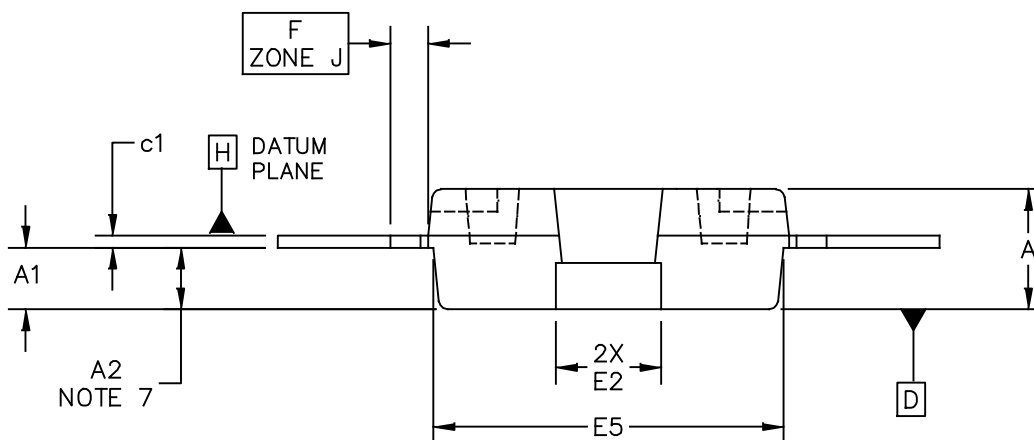
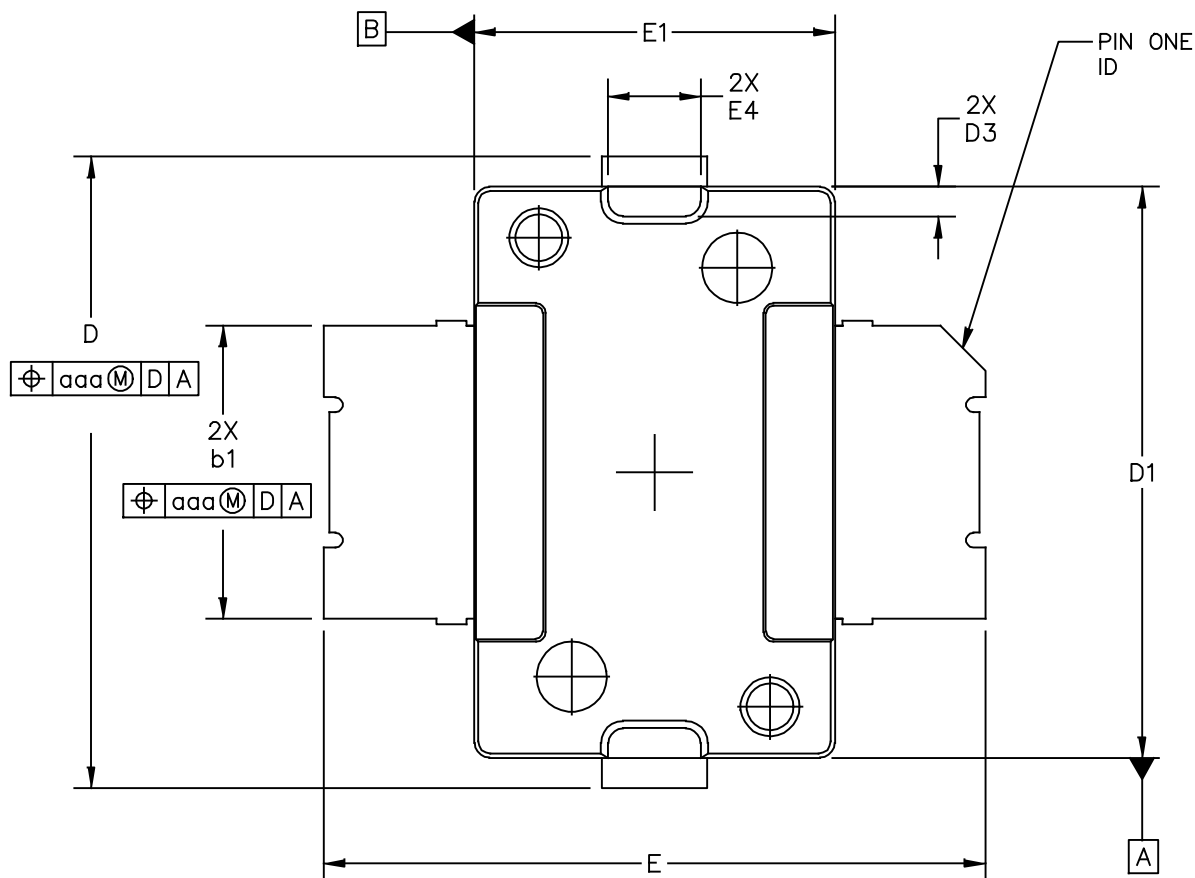
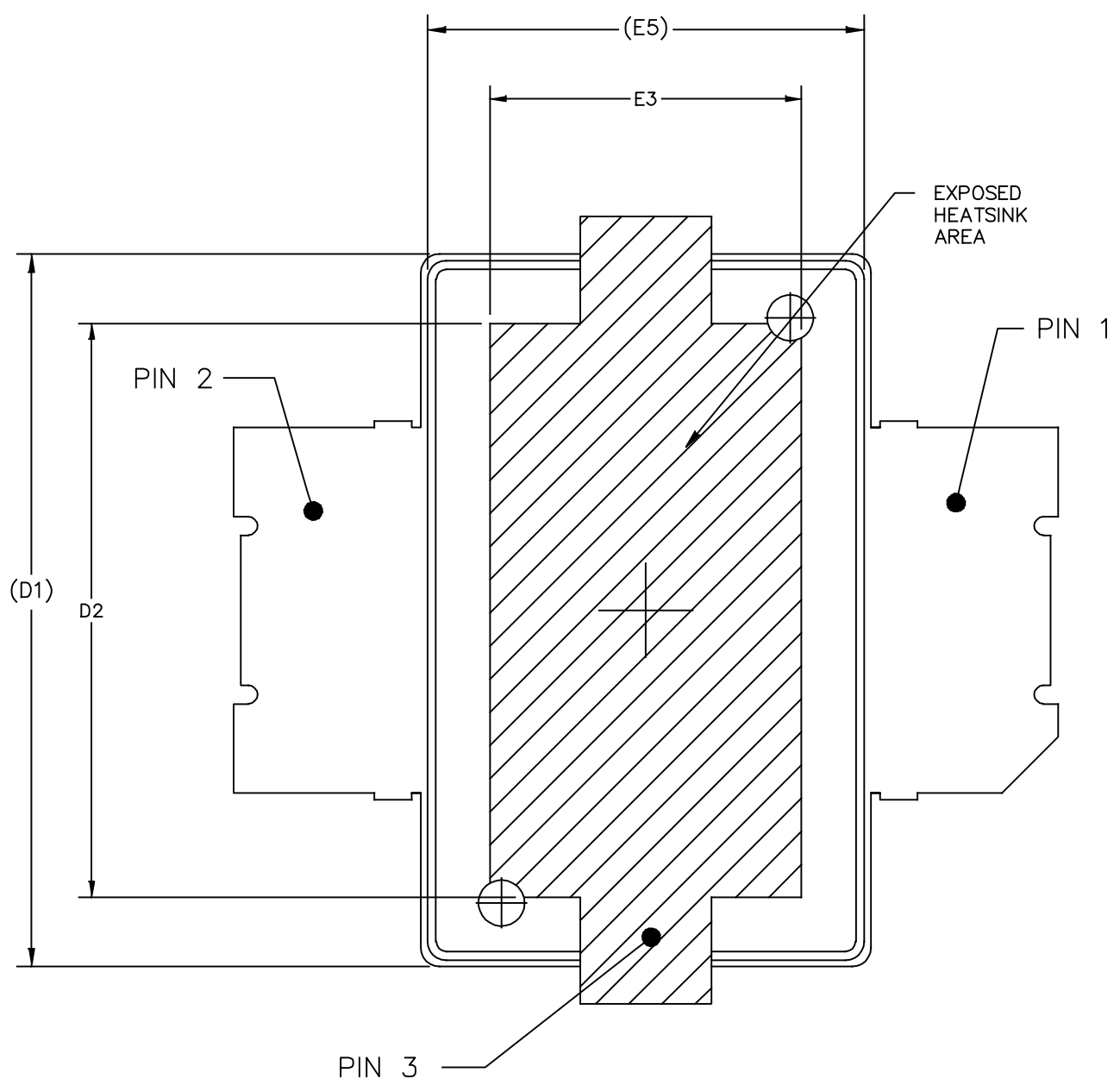

Figure 15. Broadband Frequency Response

PACKAGE DIMENSIONS



© FREESCALE SEMICONDUCTOR, INC. ALL RIGHTS RESERVED.		MECHANICAL OUTLINE		PRINT VERSION NOT TO SCALE	
TITLE: TO-270 SURFACE MOUNT			DOCUMENT NO: 98ASH98117A		REV: K
			CASE NUMBER: 1265-09		29 JUN 2007
			STANDARD: JEDEC TO-270 AA		



BOTTOM VIEW

© FREESCALE SEMICONDUCTOR, INC. ALL RIGHTS RESERVED.	MECHANICAL OUTLINE	PRINT VERSION NOT TO SCALE	
TITLE: TO-270 SURFACE MOUNT	DOCUMENT NO: 98ASH98117A	REV: K	
	CASE NUMBER: 1265-09	29 JUN 2007	
	STANDARD: JEDEC TO-270 AA		

NOTES:

1. CONTROLLING DIMENSION: INCH
2. INTERPRET DIMENSIONS AND TOLERANCES PER ASME Y14.5M-1994.
3. DATUM PLANE -H- IS LOCATED AT TOP OF LEAD AND IS COINCIDENT WITH THE LEAD WHERE THE LEAD EXITS THE PLASTIC BODY AT THE TOP OF THE PARTING LINE.
4. DIMENSIONS "D1" AND "E1" DO NOT INCLUDE MOLD PROTRUSION. ALLOWABLE PROTRUSION IS .006 PER SIDE. DIMENSIONS "D1 AND "E1" DO INCLUDE MOLD MISMATCH AND ARE DETERMINED AT DATUM PLANE -H-.
5. DIMENSION "b1" DOES NOT INCLUDE DAMBAR PROTRUSION. ALLOWABLE DAMBAR PROTRUSION SHALL BE .005 TOTAL IN EXCESS OF THE "b1" DIMENSION AT MAXIMUM MATERIAL CONDITION.
6. DATUMS -A- AND -B- TO BE DETERMINED AT DATUM PLANE -H-.
7. DIMENSION "A2" APPLIES WITHIN ZONE "J" ONLY.
8. DIMENSIONS "D" AND "E2" DO NOT INCLUDE MOLD PROTRUSION. OVERALL LENGTH INCLUDING MOLD PROTRUSION SHOULD NOT EXCEED 0.430 INCH FOR DIMENSION "D" AND 0.080 INCH FOR DIMENSION "E2". DIMENSIONS "D" AND "E2" DO INCLUDE MOLD MISMATCH AND ARE DETERMINED AT DATUM PLANE -D-.

STYLE 1:

- PIN 1 - DRAIN
- PIN 2 - GATE
- PIN 3 - SOURCE

DIM	INCH		MILLIMETER		DIM	INCH		MILLIMETER	
	MIN	MAX	MIN	MAX		MIN	MAX	MIN	MAX
A	.078	.082	1.98	2.08	F	.025 BSC		0.64 BSC	
A1	.039	.043	0.99	1.09	b1	.193	.199	4.90	5.06
A2	.040	.042	1.02	1.07	c1	.007	.011	0.18	0.28
D	.416	.424	10.57	10.77	aaa	.004		0.10	
D1	.378	.382	9.60	9.70					
D2	.290	----	7.37	----					
D3	.016	.024	0.41	0.61					
E	.436	.444	11.07	11.28					
E1	.238	.242	6.04	6.15					
E2	.066	.074	1.68	1.88					
E3	.150	----	3.81	----					
E4	.058	.066	1.47	1.68					
E5	.231	.235	5.87	5.97					
© FREESCALE SEMICONDUCTOR, INC. ALL RIGHTS RESERVED.			MECHANICAL OUTLINE			PRINT VERSION NOT TO SCALE			
TITLE: TO-270 SURFACE MOUNT					DOCUMENT NO: 98ASH98117A			REV: K	
					CASE NUMBER: 1265-09			29 JUN 2007	
					STANDARD: JEDEC TO-270 AA				

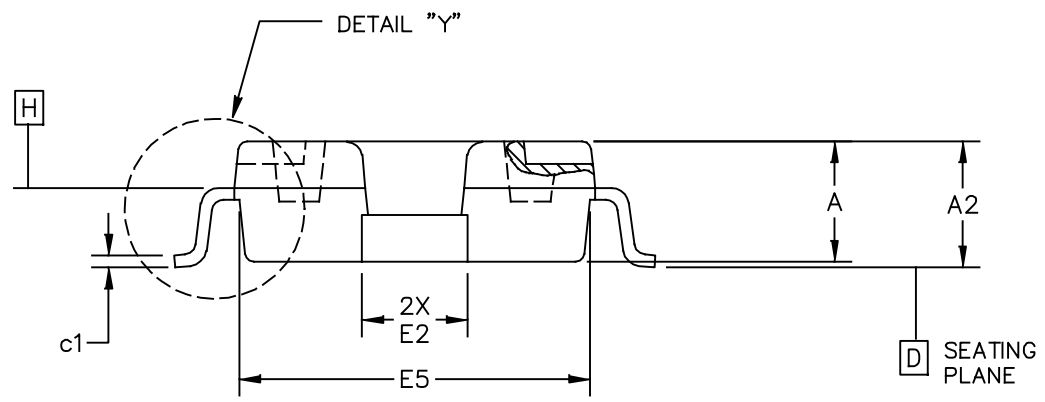
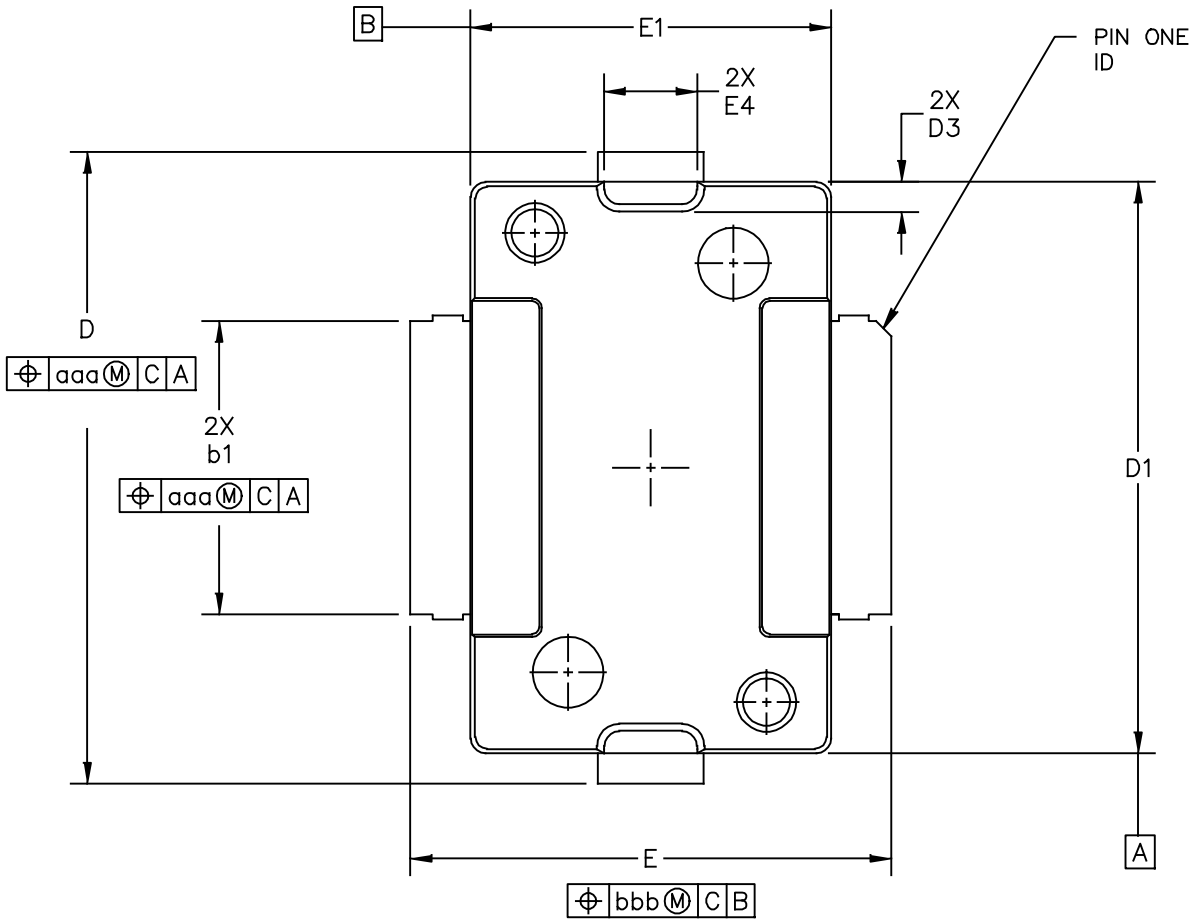

© FREESCALE SEMICONDUCTOR, INC. ALL RIGHTS RESERVED.		MECHANICAL OUTLINE		PRINT VERSION NOT TO SCALE	
TITLE: TO-270 GULL WING		DOCUMENT NO: 98ASA99301D		REV: C	
		CASE NUMBER: 1265A-03		02 JUL 2007	
		STANDARD: JEDEC TO-270 BA			

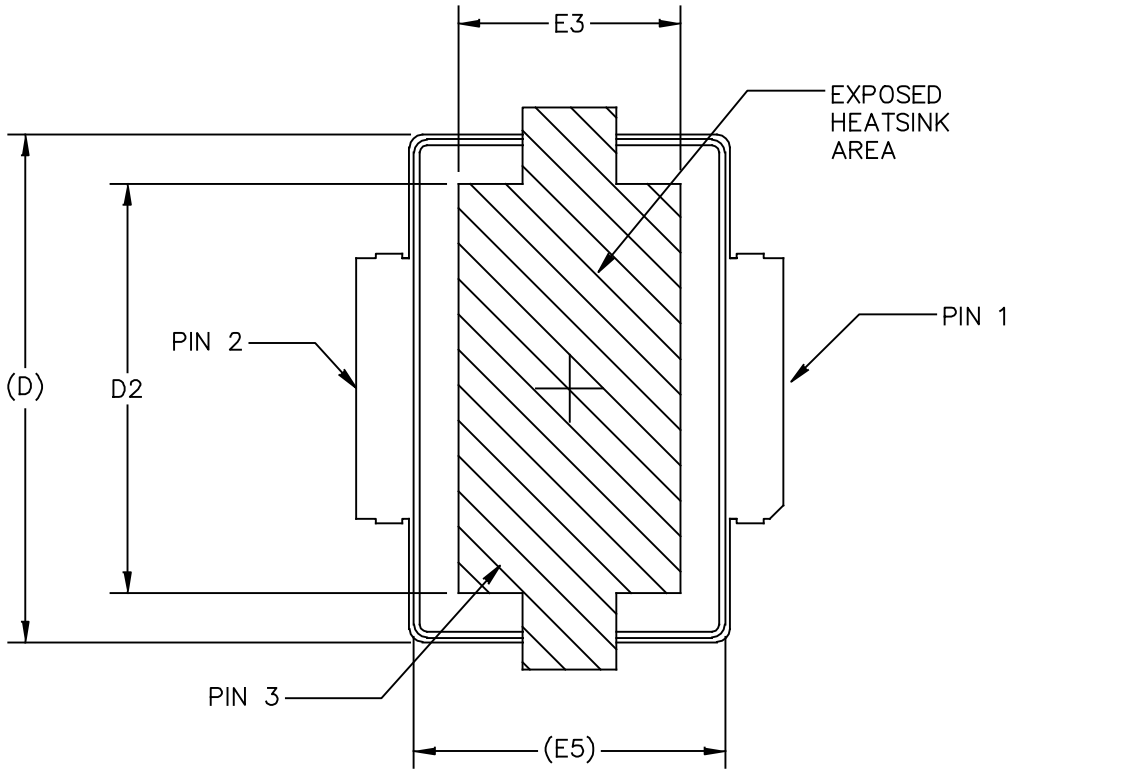

BOTTOM VIEW

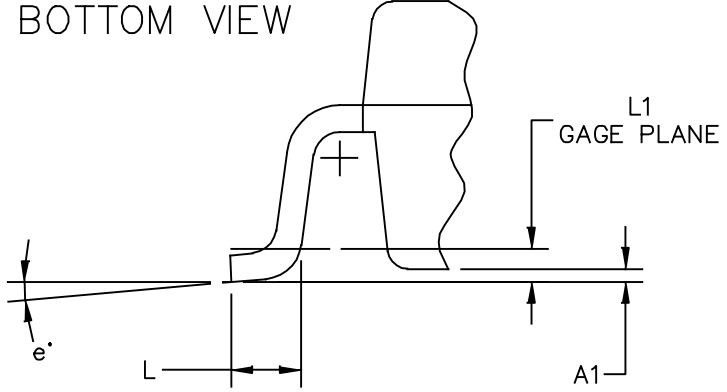

DETAIL "Y"

© FREESCALE SEMICONDUCTOR, INC. ALL RIGHTS RESERVED.	MECHANICAL OUTLINE	PRINT VERSION NOT TO SCALE	
TITLE: TO-270 GULL WING	DOCUMENT NO: 98ASA99301D	REV: C	
	CASE NUMBER: 1265A-03	02 JUL 2007	
	STANDARD: JEDEC TO-270 BA		

NOTES:

1. CONTROLLING DIMENSION: INCH
2. INTERPRET DIMENSIONS AND TOLERANCES PER ASME Y14.5M-1994.
3. DATUM PLANE -H- IS LOCATED AT TOP OF LEAD AND IS COINCIDENT WITH THE LEAD WHERE THE LEAD EXITS THE PLASTIC BODY AT THE TOP OF THE PARTING LINE.
4. DIMENSIONS "D1" AND "E1" DO NOT INCLUDE MOLD PROTRUSION. ALLOWABLE PROTRUSION IS .006 PER SIDE. DIMENSIONS "D1 AND "E1" DO INCLUDE MOLD MISMATCH AND ARE DETERMINED AT DATUM PLANE -H-.
5. DIMENSION b1 DOES NOT INCLUDE DAMBAR PROTRUSION. ALLOWABLE DAMBAR PROTRUSION SHALL BE .005 TOTAL IN EXCESS OF THE b1 DIMENSION AT MAXIMUM MATERIAL CONDITION.
6. DATUMS -A- AND -B- TO BE DETERMINED AT DATUM PLANE -H-.
7. DIMENSIONS "D" AND "E2" DO NOT INCLUDE MOLD PROTRUSION. ALLOWABLE PROTRUSION IS .003 PER SIDE. DIMENSIONS "D AND "E2" DO INCLUDE MOLD MISMATCH AND ARE DETERMINED AT DATUM PLANE -D-.

STYLE 1:

- PIN 1 - DRAIN
- PIN 2 - GATE
- PIN 3 - SOURCE

DIM	INCH		MILLIMETER		DIM	INCH		MILLIMETER	
	MIN	MAX	MIN	MAX		MIN	MAX	MIN	MAX
A	.078	.082	1.98	2.08	L	.018	.024	0.46	0.61
A1	.001	.004	0.02	0.10	L1	.01 BSC		0.25 BSC	
A2	.077	.088	1.96	2.24	b1	.193	.199	4.90	5.06
D	.416	.424	10.57	10.77	c1	.007	.011	0.18	0.28
D1	.378	.382	9.60	9.70	e	2'	8'	2'	8'
D2	.290	-	7.37	-	aaa	.004		0.10	
D3	.016	.024	0.41	0.61					
E	.316	.324	8.03	8.23					
E1	.238	.242	6.04	6.15					
E2	.066	.074	1.68	1.88					
E3	.150	-	3.81	-					
E4	.058	.066	1.47	1.68					
E5	.231	.235	5.87	5.97					
© FREESCALE SEMICONDUCTOR, INC. ALL RIGHTS RESERVED.			MECHANICAL OUTLINE			PRINT VERSION NOT TO SCALE			
TITLE: TO-270 GULL WING					DOCUMENT NO: 98ASA99301D			REV: C	
					CASE NUMBER: 1265A-03			02 JUL 2007	
					STANDARD: JEDEC TO-270 BA				

PRODUCT DOCUMENTATION, SOFTWARE AND TOOLS

Refer to the following documents, software and tools to aid your design process.

Application Notes

- AN1907: Solder Reflow Attach Method for High Power RF Devices in Plastic Packages
- AN1955: Thermal Measurement Methodology of RF Power Amplifiers
- AN3789: Clamping of High Power RF Transistors and RFICs in Over-Molded Plastic Packages

Engineering Bulletins

- EB212: Using Data Sheet Impedances for RF LDMOS Devices

Software

- Electromigration MTTF Calculator
- RF High Power Model
- .s2p File

Development Tools

- Printed Circuit Boards

For Software and Tools, do a Part Number search at <http://www.freescale.com>, and select the “Part Number” link. Go to the Software & Tools tab on the part’s Product Summary page to download the respective tool.

REVISION HISTORY

The following table summarizes revisions to this document.

Revision	Date	Description
0	Apr. 2013	<ul style="list-style-type: none"> • Initial Release of Data Sheet
1	Nov. 2013	<ul style="list-style-type: none"> • Upper frequency limit changed from 2690 to 2700 MHz to reflect measurement data, p. 1 • Table 2, Thermal Characteristics: changed 2170 to 2140 MHz to reflect recent thermal test results, p. 2 • Table 5, Electrical Characteristics, Load Mismatch: updated VSWR power levels (8 W CW to 14 W CW, 7 W CW to 12 W CW) to reflect recent characterization data test results, p. 3 • Table 5, Electrical Characteristics, Typical Performance: changed P1dB from 7 W to 16.2 W based on P3dB load pull calculations, p. 3 • Figs. 2, 8, 12, Test Circuit Component Layout: added MTL number, pp. 4, 7, 9 • Tables 6, 7, 8, Test Circuit Component Designations and Values: updated PCB description to reflect most current board specifications from Rogers and added MTL part number, pp. 4, 7, 9

How to Reach Us:

Home Page:
freescale.com

Web Support:
freescale.com/support

Information in this document is provided solely to enable system and software implementers to use Freescale products. There are no express or implied copyright licenses granted hereunder to design or fabricate any integrated circuits based on the information in this document.

Freescale reserves the right to make changes without further notice to any products herein. Freescale makes no warranty, representation, or guarantee regarding the suitability of its products for any particular purpose, nor does Freescale assume any liability arising out of the application or use of any product or circuit, and specifically disclaims any and all liability, including without limitation consequential or incidental damages. "Typical" parameters that may be provided in Freescale data sheets and/or specifications can and do vary in different applications, and actual performance may vary over time. All operating parameters, including "typicals," must be validated for each customer application by customer's technical experts. Freescale does not convey any license under its patent rights nor the rights of others. Freescale sells products pursuant to standard terms and conditions of sale, which can be found at the following address: freescale.com/SalesTermsandConditions.

Freescale and the Freescale logo are trademarks of Freescale Semiconductor, Inc., Reg. U.S. Pat. & Tm. Off. Airfast is a trademark of Freescale Semiconductor, Inc. All other product or service names are the property of their respective owners.

© 2013 Freescale Semiconductor, Inc.

Looking for pricing, stock, or lifecycle information?

Click below to explore more details on WIN SOURCE:

⊖ [View AFT20S015GNR1](#) on WIN SOURCE

⊖ [NXP / Nexperia](#) Information

Optimize Your Supply Chain with WIN SOURCE Solutions

- ✓ Global Sourcing Solution
- ✓ Obsolete Management
- ✓ Cost Control Management
- ✓ Shortage Management
- ✓ Alternative Solution
- ✓ Excess Inventory Management