



**THE DATASHEET OF  
AFT21S230SR5**



# RF Power LDMOS Transistors

## N-Channel Enhancement-Mode Lateral MOSFETs

These 50 W RF power LDMOS transistors are designed for cellular base station applications covering the frequency range of 2110 to 2170 MHz.

- Typical Single-Carrier W-CDMA Performance:  $V_{DD} = 28$  Vdc,  $I_{DQ} = 1500$  mA,  $P_{out} = 50$  W Avg., Input Signal PAR = 9.9 dB @ 0.01% Probability on CCDF.

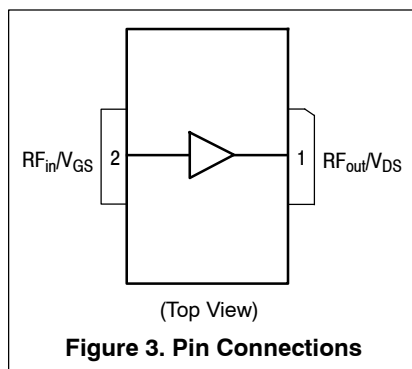
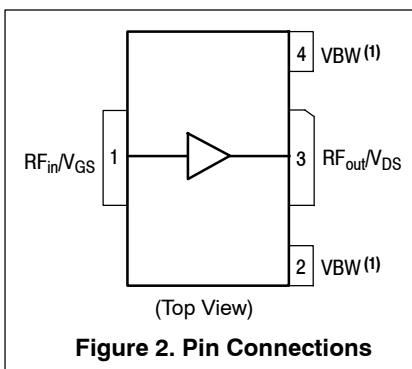
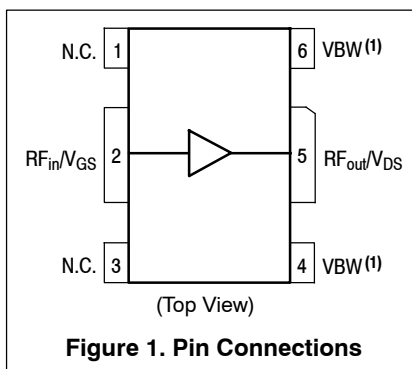
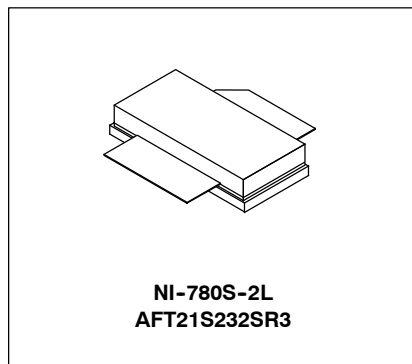
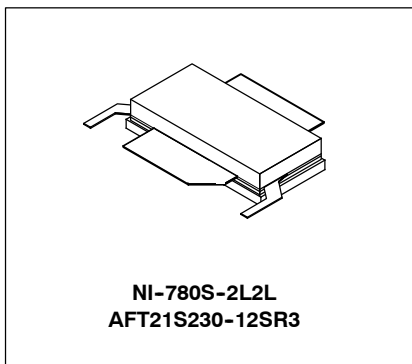
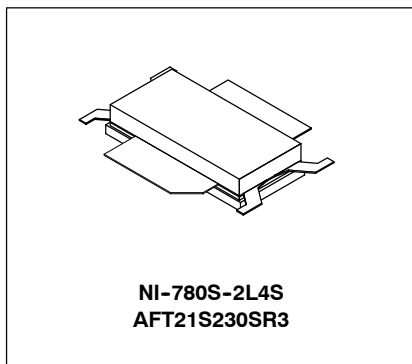
Frequency	$G_{ps}$ (dB)	$\eta_D$ (%)	Output PAR (dB)	ACPR (dBc)	IRL (dB)
2110 MHz	16.7	30.5	7.2	-35.7	-19
2140 MHz	17.0	31.0	7.1	-35.4	-20
2170 MHz	17.2	31.8	7.0	-34.8	-15

**AFT21S230SR3**  
**AFT21S230-12SR3**  
**AFT21S232SR3**

**2110–2170 MHz, 50 W AVG., 28 V**  
**AIRFAST RF POWER LDMOS**  
**TRANSISTORS**

### Features

- Greater Negative Gate-Source Voltage Range for Improved Class C Operation
- Designed for Digital Predistortion Error Correction Systems
- Optimized for Doherty Applications
- NI-780S-2L2L, NI-780S-2L4S: R3 Suffix = 250 Units, 44 mm Tape Width, 13-inch Reel.
- NI-780S-2L: R3 Suffix = 250 Units, 56 mm Tape Width, 13-inch Reel. For R5 Tape and Reel options, see p. 17.



1. Device can operate with the  $V_{DD}$  current supplied through pin 4 and pin 6 (AFT21S230S) or pin 2 and pin 4 (AFT21S230-12S) at a reduced RF output power level. Refer to CW operation data in the Maximum Ratings table.

**Table 1. Maximum Ratings**

Rating	Symbol	Value	Unit
Drain-Source Voltage	$V_{DSS}$	-0.5, +65	Vdc
Gate-Source Voltage	$V_{GS}$	-6.0, +10	Vdc
Operating Voltage	$V_{DD}$	32, +0	Vdc
Storage Temperature Range	$T_{stg}$	-65 to +150	°C
Case Operating Temperature Range	$T_C$	-40 to +150	°C
Operating Junction Temperature Range (1,2)	$T_J$	-40 to +225	°C
CW Operation @ $T_C = 25^\circ\text{C}$ when DC current is fed through drain lead, pin 5 (AFT21S230S), pin 3 (AFT21S230-12S) or pin 1 (AFT21S232S) Derate above 25°C	CW	161 0.75	W W/°C
CW Operation @ $T_C = 25^\circ\text{C}$ when DC current is fed through pin 4 and pin 6 (AFT21S230S) or pin 2 and pin 4 (AFT21S230-12S) Derate above 25°C	CW	104 0.44	W W/°C

**Table 2. Thermal Characteristics**

Characteristic	Symbol	Value (2,3)	Unit
Thermal Resistance, Junction to Case Case Temperature 80°C, 50 W CW, 28 Vdc, $I_{DQ} = 1500$ mA, 2110 MHz Case Temperature 86°C, 140 W CW(4), 28 Vdc, $I_{DQ} = 1500$ mA, 2110 MHz	$R_{\theta JC}$	0.43 0.38	°C/W

**Table 3. ESD Protection Characteristics**

Test Methodology	Class
Human Body Model (per JESD22-A114)	2
Machine Model (per EIA/JESD22-A115)	B
Charge Device Model (per JESD22-C101)	IV

**Table 4. Electrical Characteristics** ( $T_A = 25^\circ\text{C}$  unless otherwise noted)

Characteristic	Symbol	Min	Typ	Max	Unit
<b>Off Characteristics</b>					
Zero Gate Voltage Drain Leakage Current ( $V_{DS} = 65$ Vdc, $V_{GS} = 0$ Vdc)	$I_{DSS}$	—	—	10	$\mu\text{Adc}$
Zero Gate Voltage Drain Leakage Current ( $V_{DS} = 28$ Vdc, $V_{GS} = 0$ Vdc)	$I_{DSS}$	—	—	1	$\mu\text{Adc}$
Gate-Source Leakage Current ( $V_{GS} = 5$ Vdc, $V_{DS} = 0$ Vdc)	$I_{GSS}$	—	—	1	$\mu\text{Adc}$
<b>On Characteristics</b>					
Gate Threshold Voltage ( $V_{DS} = 10$ Vdc, $I_D = 291$ $\mu\text{Adc}$ )	$V_{GS(th)}$	1.5	2.0	2.5	Vdc
Gate Quiescent Voltage ( $V_{DD} = 28$ Vdc, $I_D = 1500$ mAdc, Measured in Functional Test)	$V_{GS(Q)}$	2.2	2.7	3.2	Vdc
Drain-Source On-Voltage ( $V_{GS} = 10$ Vdc, $I_D = 3.7$ Adc)	$V_{DS(on)}$	0.1	0.2	0.3	Vdc

1. Continuous use at maximum temperature will affect MTTF.
2. MTTF calculator available at <http://www.freescale.com/rf>. Select Software & Tools/Development Tools/Calculators to access MTTF calculators by product.
3. Refer to AN1955, *Thermal Measurement Methodology of RF Power Amplifiers*. Go to <http://www.freescale.com/rf>. Select Documentation/Application Notes - AN1955.
4. Exceeds recommended operating conditions. See CW operation data in Maximum Ratings table.

(continued)

**Table 4. Electrical Characteristics** ( $T_A = 25^\circ\text{C}$  unless otherwise noted) (continued)

Characteristic	Symbol	Min	Typ	Max	Unit
<b>Functional Tests</b> <sup>(1)</sup> (In Freescale Test Fixture, 50 ohm system) $V_{DD} = 28\text{ Vdc}$ , $I_{DQ} = 1500\text{ mA}$ , $P_{out} = 50\text{ W Avg.}$ , $f = 2110\text{ MHz}$ , Single-Carrier W-CDMA, IQ Magnitude Clipping, Input Signal PAR = 9.9 dB @ 0.01% Probability on CCDF. ACPR measured in 3.84 MHz Channel Bandwidth @ $\pm 5\text{ MHz}$ Offset.					
Power Gain	$G_{ps}$	16.0	16.7	19.0	dB
Drain Efficiency	$\eta_D$	29.0	30.5	—	%
Output Peak-to-Average Ratio @ 0.01% Probability on CCDF	PAR	6.7	7.2	—	dB
Adjacent Channel Power Ratio	ACPR	—	-35.7	-34.0	dBc
Input Return Loss	IRL	—	-19	-10	dB

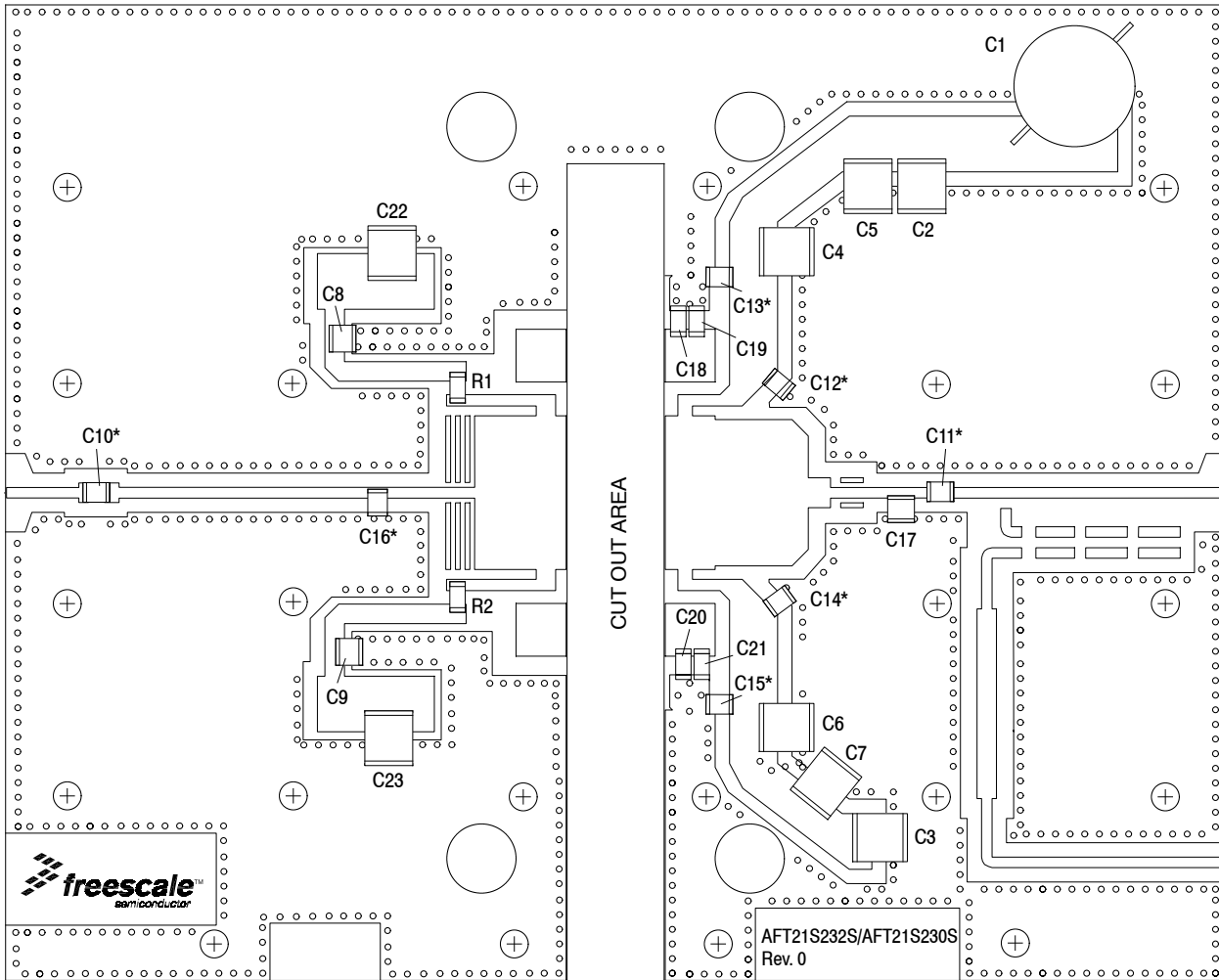
**Load Mismatch** (In Freescale Test Fixture, 50 ohm system)  $I_{DQ} = 1500\text{ mA}$ ,  $f = 2140\text{ MHz}$ 

VSWR 10:1 at 32 Vdc, 269 W CW <sup>(2)</sup> Output Power (3 dB Input Overdrive from 182 W CW <sup>(2)</sup> Rated Power)	No Device Degradation
--	-----------------------

**Typical Performance** (In Freescale Test Fixture, 50 ohm system)  $V_{DD} = 28\text{ Vdc}$ ,  $I_{DQ} = 1500\text{ mA}$ , 2110-2170 MHz Bandwidth

$P_{out}$ @ 1 dB Compression Point, CW	$P_{1dB}$	—	182 <sup>(2)</sup>	—	W
AM/PM (Maximum value measured at the P3dB compression point across the 2110-2170 MHz bandwidth)	$\Phi$	—	-19.3	—	°
VBW Resonance Point (IMD Third Order Intermodulation Inflection Point)	$VBW_{res}$	—	95 60	—	MHz
AFT21S230S AFT21S232S					
Gain Flatness in 60 MHz Bandwidth @ $P_{out} = 50\text{ W Avg.}$	$G_F$	—	0.5	—	dB
Gain Variation over Temperature ( $-30^\circ\text{C}$ to $+85^\circ\text{C}$ )	$\Delta G$	—	0.016	—	dB/°C
Output Power Variation over Temperature ( $-30^\circ\text{C}$ to $+85^\circ\text{C}$ ) <sup>(2)</sup>	$\Delta P_{1dB}$	—	0.007	—	dB/°C

1. Part internally matched both on input and output.
2. Exceeds recommended operating conditions. See CW operation data in Maximum Ratings table.



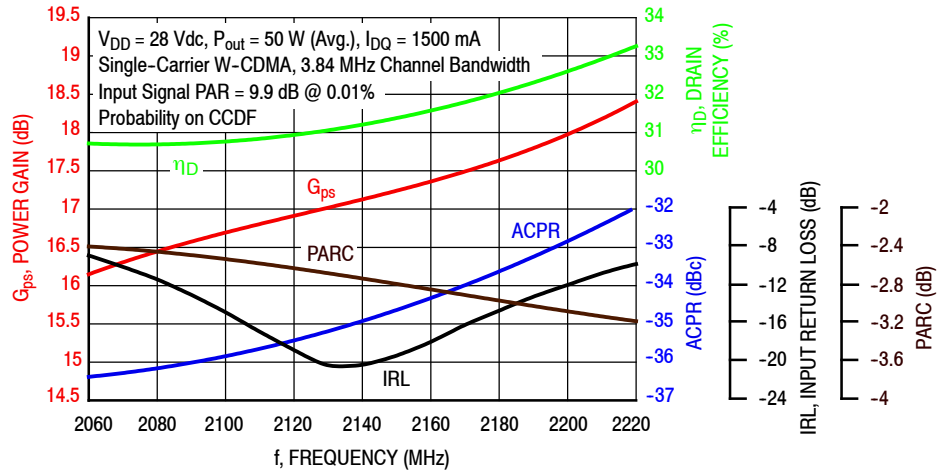
\*C10, C11, C12, C13, C14, C15 and C16 are mounted vertically.

**Figure 4. AFT21S230SR3(232SR3) Test Circuit Component Layout**

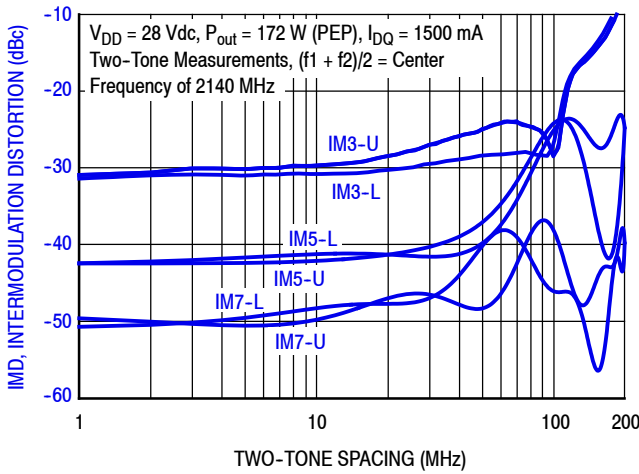
**Table 5. AFT21S230SR3(232SR3) Test Circuit Component Designations and Values**

Part	Description	Part Number	Manufacturer
C1	470 $\mu$ F, 63 V Electrolytic Capacitor	B41694A5477Q7	EPCOS
C2, C3, C4, C5, C6, C7, C22, C23	10 $\mu$ F, 100 V Chip Capacitors	C5750X7S2A106M	TDK
C8, C9, C10, C11, C12, C13, C14, C15	6.8 pF Chip Capacitors	ATC100B6R8BT500XT	ATC
C16	0.6 pF Chip Capacitor	ATC100B0R6BT500XT	ATC
C17	0.3 pF Chip Capacitor	ATC100B0R3BT500XT	ATC
C18, C19, C20, C21	1 $\mu$ F, 50 V Chip Capacitors	CDR34BX104AKWS	AVX
R1, R2	8.2 $\Omega$ , 1/4 W Chip Resistors	RC1206FR-108R2L	Yageo
PCB	Rogers RO4350B, 0.020", $\epsilon_r = 3.66$	—	MTL

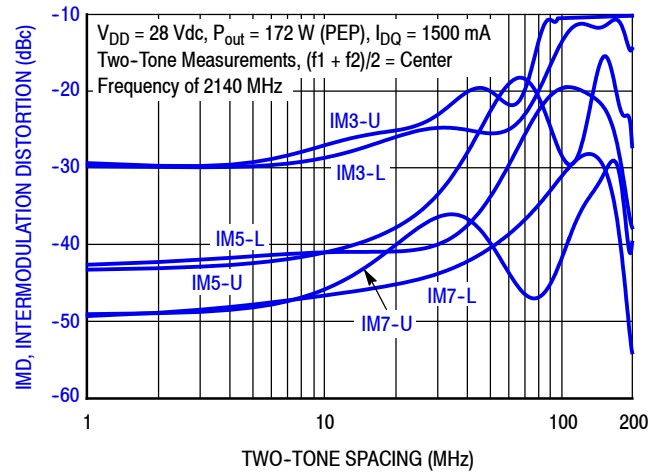
### TYPICAL CHARACTERISTICS



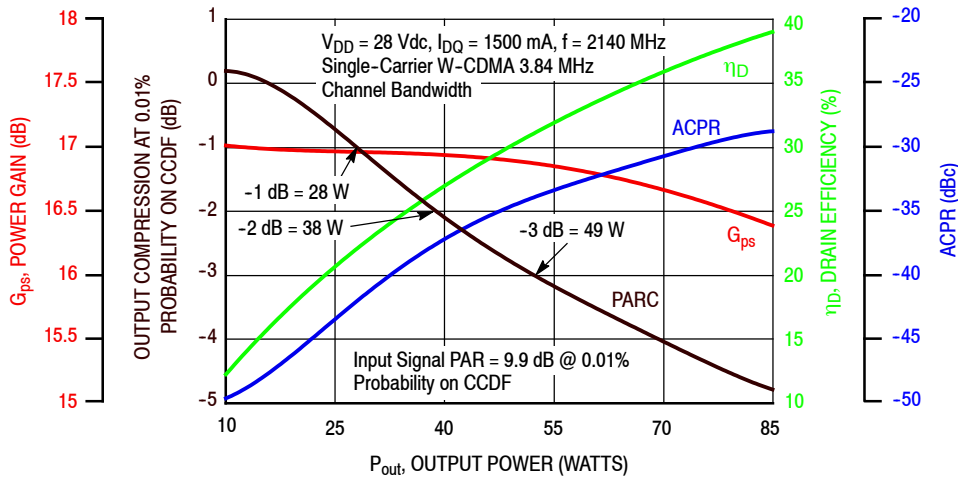
**Figure 5. Single-Carrier Output Peak-to-Average Ratio Compression (PARC) Broadband Performance @  $P_{out} = 50$  Watts Avg.**



**Figure 6a. Intermodulation Distortion Products versus Two-Tone Spacing — AFT21S230S**

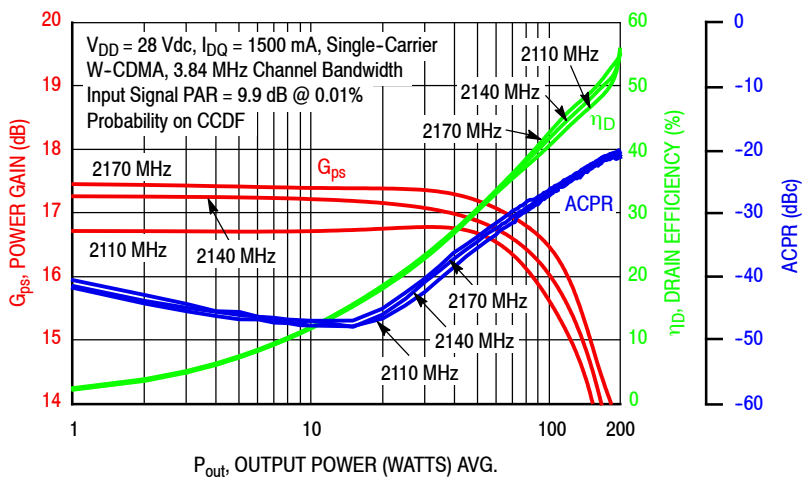


**Figure 6b. Intermodulation Distortion Products versus Two-Tone Spacing — AFT21S232S**

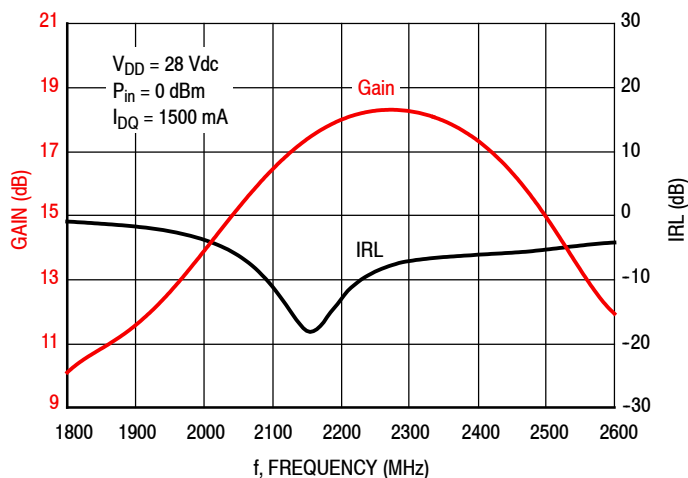


**Figure 7. Output Peak-to-Average Ratio Compression (PARC) versus Output Power**

### TYPICAL CHARACTERISTICS



**Figure 8. Single-Carrier W-CDMA Power Gain, Drain Efficiency and ACPR versus Output Power**



**Figure 9. Broadband Frequency Response**

$V_{DD} = 28 \text{ Vdc}$ ,  $I_{DQ} = 1500 \text{ mA}$ , Pulsed CW, 10  $\mu\text{sec(ON)}$ , 10% Duty Cycle

f (MHz)	$Z_{\text{source}} (\Omega)$	$Z_{\text{in}} (\Omega)$	$Z_{\text{load}}^{(1)} (\Omega)$	Max Linear Gain (dB)	Max Output Power							
					P1dB				P3dB			
					(dBm)	(W)	$\eta_D$ (%)	AM/PM (°)	(dBm)	(W)	$\eta_D$ (%)	AM/PM (°)
2110	1.20 - j6.00	1.20 + j5.90	1.50 - j3.90	17.7	54.3	269	55.4	11	55.2	331	57.0	16
2140	1.70 - j6.40	1.50 + j6.30	1.60 - j4.00	17.7	54.3	269	55.1	10	55.2	331	56.0	15
2170	1.70 - j6.80	1.75 + j6.70	1.50 - j4.00	17.8	54.3	269	54.7	11	55.2	331	56.0	16

(1) Load impedance for optimum P1dB power.

$Z_{\text{source}}$  = Measured impedance presented to the input of the device at the package reference plane.

$Z_{\text{in}}$  = Impedance as measured from gate contact to ground.

$Z_{\text{load}}$  = Measured impedance presented to the output of the device at the package reference plane.

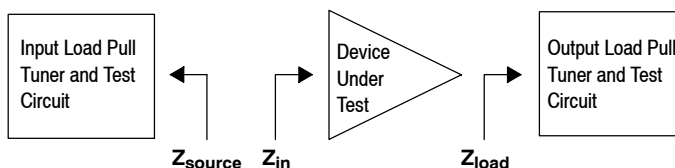


Figure 10. Load Pull Performance — Maximum P1dB Tuning

$V_{DD} = 28 \text{ Vdc}$ ,  $I_{DQ} = 1500 \text{ mA}$ , Pulsed CW, 10  $\mu\text{sec(ON)}$ , 10% Duty Cycle

f (MHz)	$Z_{\text{source}} (\Omega)$	$Z_{\text{in}} (\Omega)$	$Z_{\text{load}}^{(1)} (\Omega)$	Max Linear Gain (dB)	Max Drain Efficiency							
					P1dB				P3dB			
					(dBm)	(W)	$\eta_D$ (%)	AM/PM (°)	(dBm)	(W)	$\eta_D$ (%)	AM/PM (°)
2110	1.20 - j6.00	1.20 + j5.93	2.10 - j2.41	20.0	52.7	186	64.9	16	54.3	269	66.2	20
2140	1.70 - j6.40	1.40 + j6.30	1.80 - j2.60	19.8	52.8	191	64.2	16	53.4	219	65.4	24
2170	1.70 - j6.80	1.80 + j6.80	1.70 - j2.60	20.0	52.8	191	64.2	17	54.2	263	65.5	22

(1) Load impedance for optimum P1dB efficiency.

$Z_{\text{source}}$  = Measured impedance presented to the input of the device at the package reference plane.

$Z_{\text{in}}$  = Impedance as measured from gate contact to ground.

$Z_{\text{load}}$  = Measured impedance presented to the output of the device at the package reference plane.

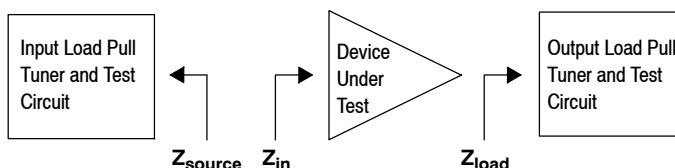


Figure 11. Load Pull Performance — Maximum Drain Efficiency Tuning

### P1dB - TYPICAL LOAD PULL CONTOURS — 2140 MHz

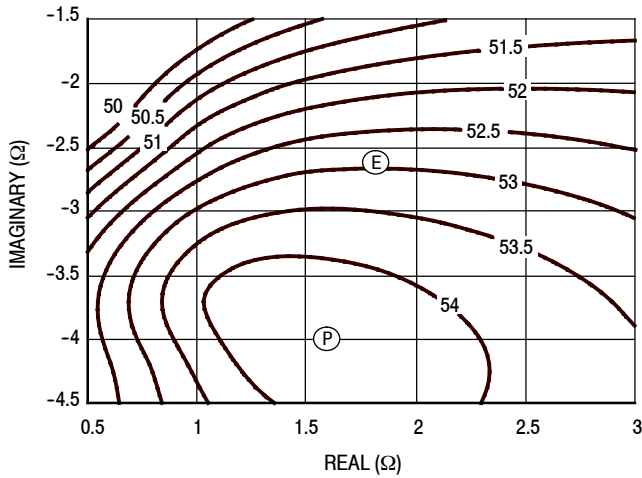


Figure 12. P1dB Load Pull Output Power Contours (dBm)

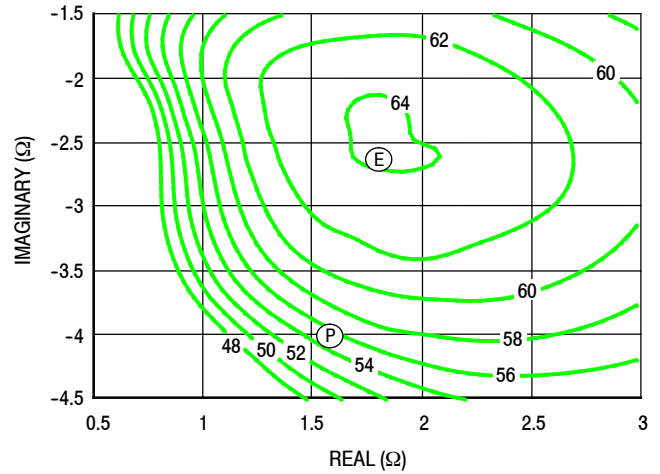


Figure 13. P1dB Load Pull Efficiency Contours (%)

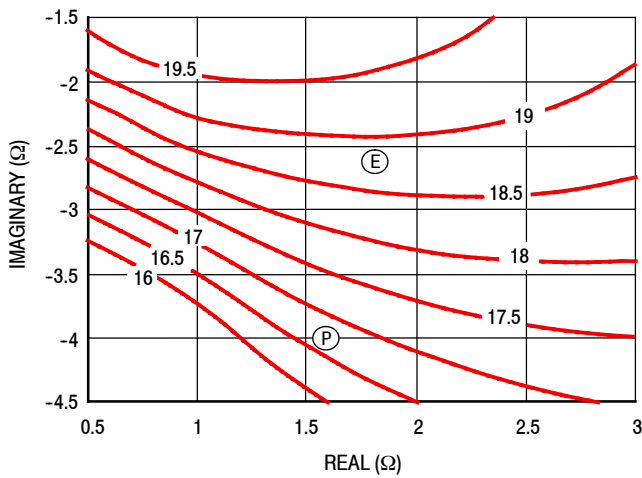


Figure 14. P1dB Load Pull Gain Contours (dB)

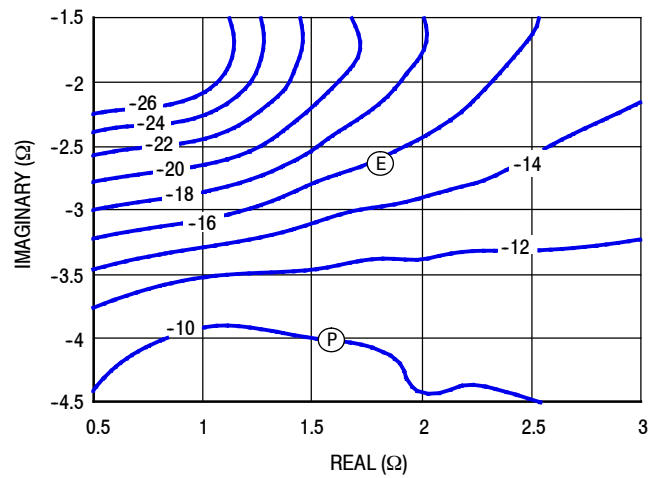
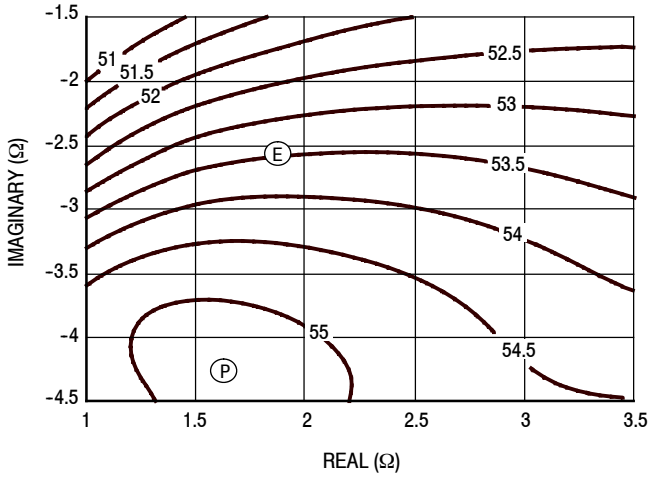


Figure 15. P1dB Load Pull AM/PM Contours (°)

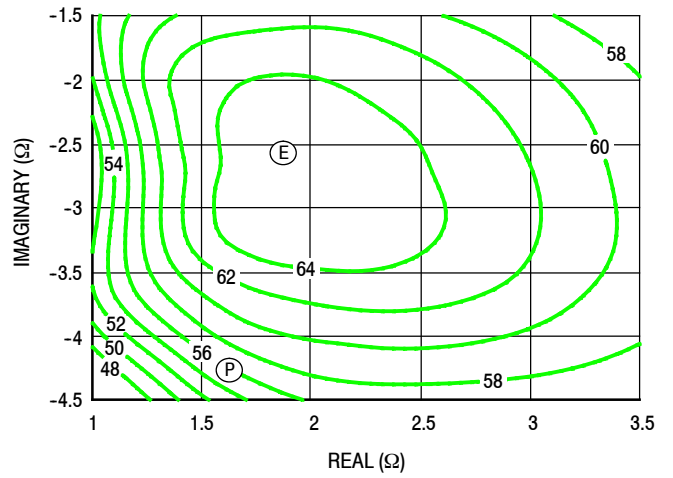
**NOTE:** (P) = Maximum Output Power  
(E) = Maximum Drain Efficiency

- Gain
- Drain Efficiency
- Linearity
- Output Power

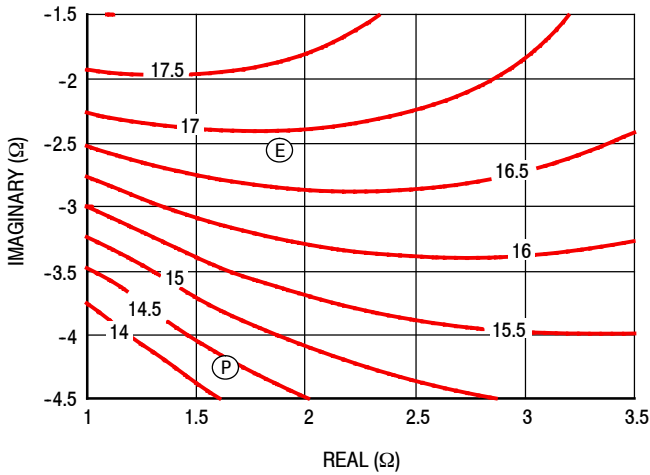
**P3dB - TYPICAL LOAD PULL CONTOURS — 2140 MHz**



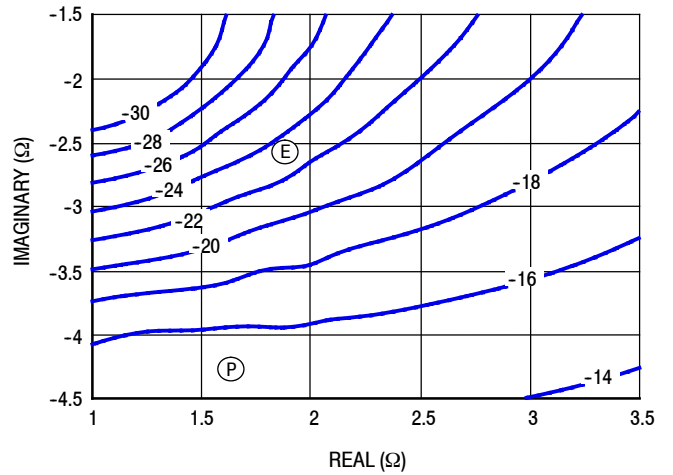
**Figure 16. P3dB Load Pull Output Power Contours (dBm)**



**Figure 17. P3dB Load Pull Efficiency Contours (%)**



**Figure 18. P3dB Load Pull Gain Contours (dB)**

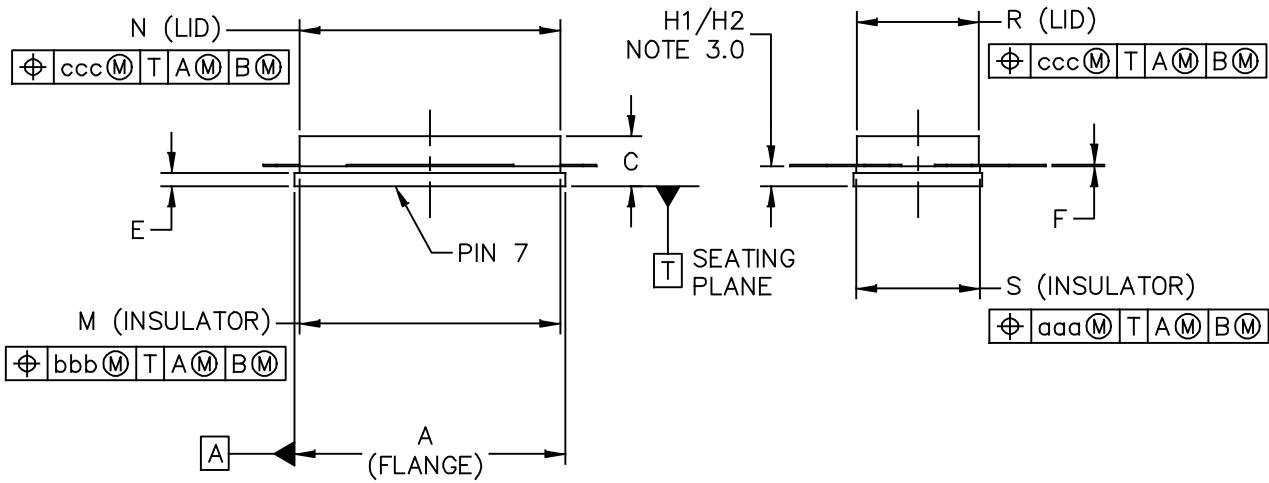
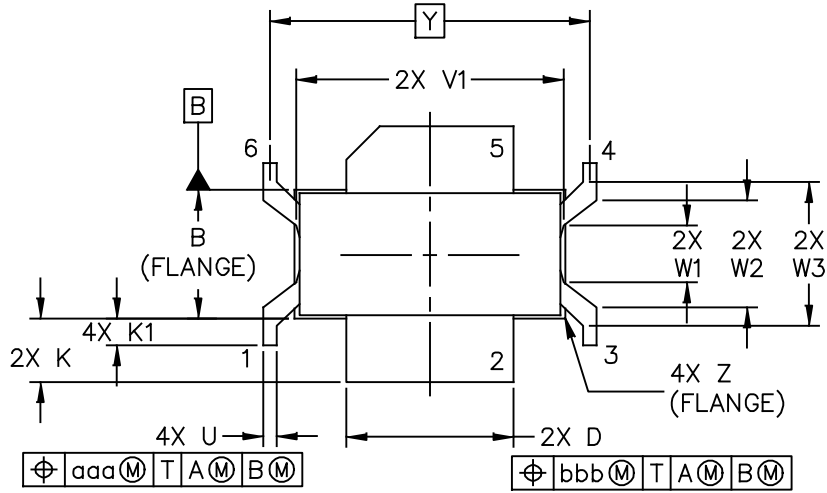


**Figure 19. P3dB Load Pull AM/PM Contours (°)**

**NOTE:** (P) = Maximum Output Power  
 (E) = Maximum Drain Efficiency

- Gain
- Drain Efficiency
- Linearity
- Output Power

### PACKAGE DIMENSIONS



© FREESCALE SEMICONDUCTOR, INC. ALL RIGHTS RESERVED.	MECHANICAL OUTLINE	PRINT VERSION NOT TO SCALE	
TITLE:  NI-780S-6	DOCUMENT NO: 98ASA00443D	REV: A	
	CASE NUMBER: 2268-02	24 MAY 2012	
	STANDARD: NON-JEDEC		

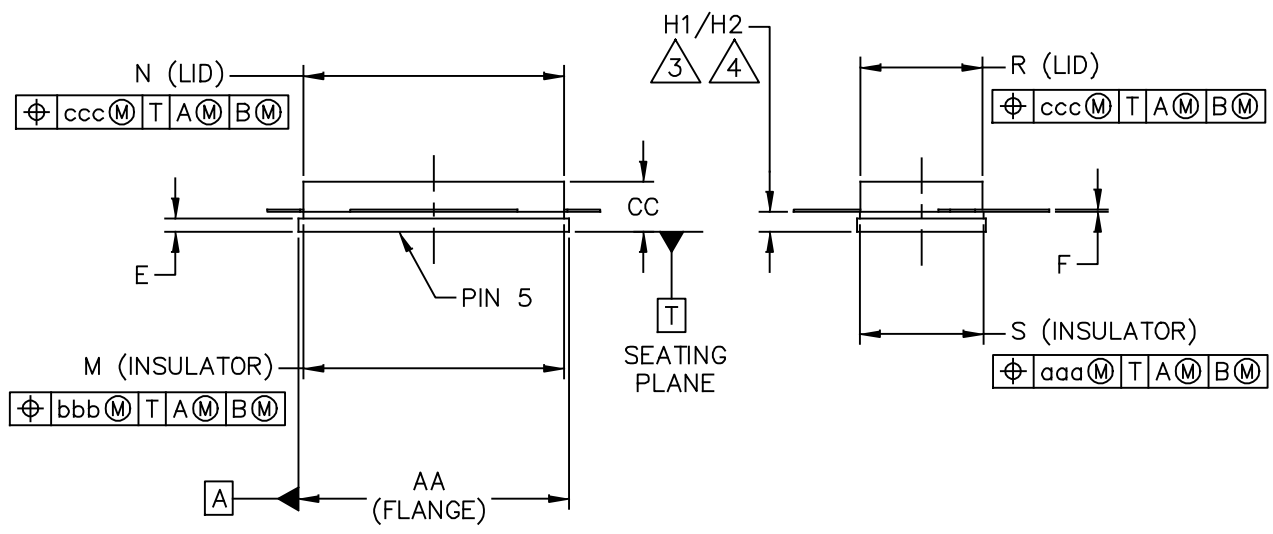
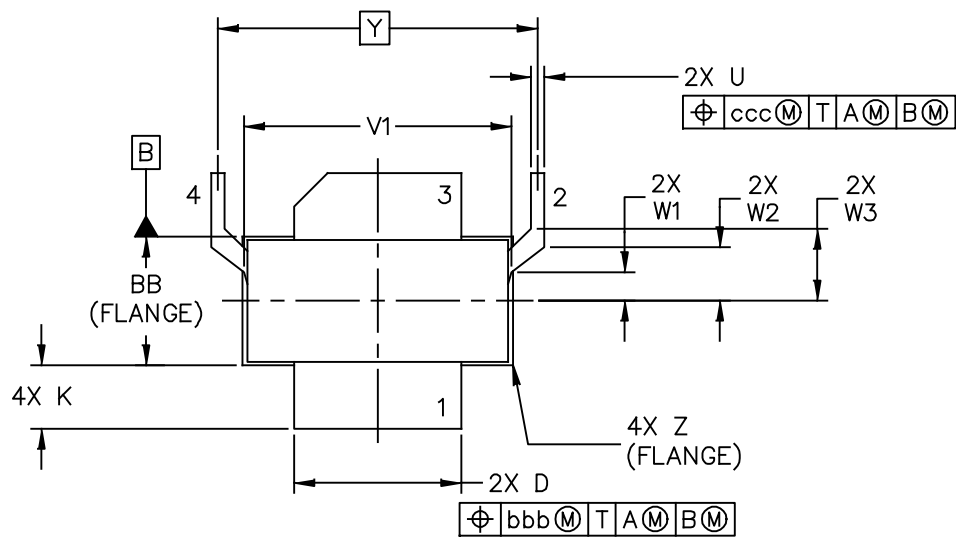
NOTES:

1.0 CONTROLLING DIMENSION: INCH.

2.0 INTERPRET DIMENSIONS AND TOLERANCES PER ASME Y14.5M-1994.

3.0 DIMENSIONS H1 AND H2 ARE MEASURED .030 INCH (0.762 MM) AWAY FROM FLANGE PARALLEL TO DATUM B. H1 APPLIES TO PINS 2 & 5. H2 APPLIES TO PINS 1, 3, 4 & 6.

DIM	INCH		MILLIMETER		DIM	INCH		MILLIMETER	
	MIN	MAX	MIN	MAX		MIN	MAX	MIN	MAX
A	.805	– .815	20.45	– 20.70	R	.365	– .375	9.27	– 9.53
B	.380	– .390	9.65	– 9.91	S	.365	– .375	9.27	– 9.53
C	.125	– .170	3.18	– 4.32	U	.035	– .045	0.89	– 1.14
D	.495	– .505	12.57	– 12.83	V1	.795	– .805	20.19	– 20.45
E	.035	– .045	0.89	– 1.14	W1	.165	– .175	4.19	– 4.45
F	.004	– .007	0.10	– 0.18	W2	.315	– .325	8.00	– 8.26
H1	.057	– .067	1.45	– 1.70	W3	.425	– .435	10.80	– 11.05
H2	.054	– .070	1.37	– 1.78	Y	.956 BSC		24.28 BSC	
K	.170	– .210	4.32	– 5.33	Z	R.000 – R.040		R.00 – R1.02	
K1	.070	– .090	1.78	– 2.29	aaa	– .005	–	–	0.127 –
M	.774	– .786	19.66	– 19.96	bbb	– .010	–	–	0.254 –
N	.772	– .788	19.61	– 20.02	ccc	– .015	–	–	0.381 –
© FREESCALE SEMICONDUCTOR, INC. ALL RIGHTS RESERVED.			MECHANICAL OUTLINE			PRINT VERSION NOT TO SCALE			
TITLE:  NI-780S-6					DOCUMENT NO: 98ASA00443D			REV: A	
					CASE NUMBER: 2268-02			24 MAY 2012	
					STANDARD: NON-JEDEC				



© FREESCALE SEMICONDUCTOR, INC. ALL RIGHTS RESERVED.	MECHANICAL OUTLINE	PRINT VERSION NOT TO SCALE
TITLE:  NI-780-2S2L	DOCUMENT NO: 98ASA00517D	REV: A
	STANDARD: NON-JEDEC	
	08 MAR 2013	

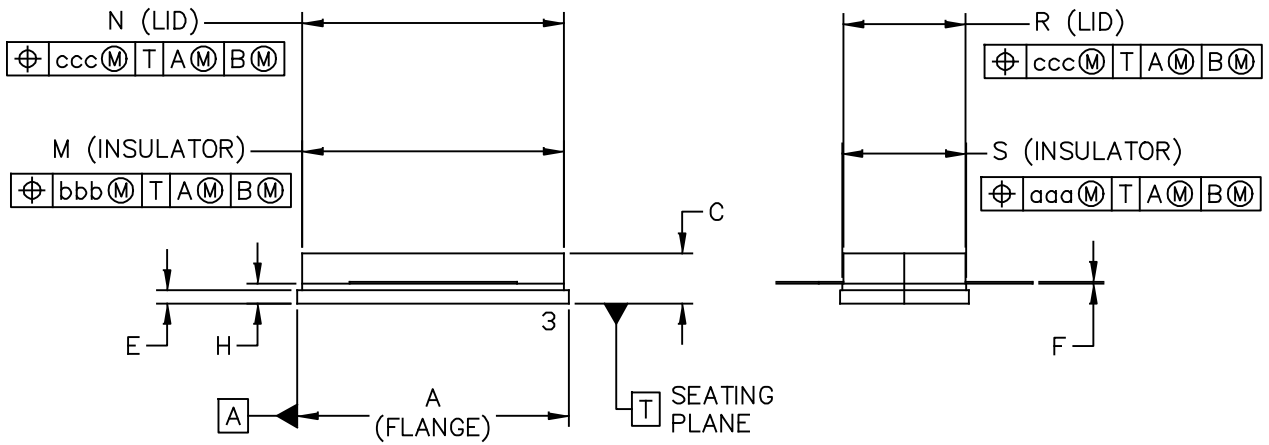
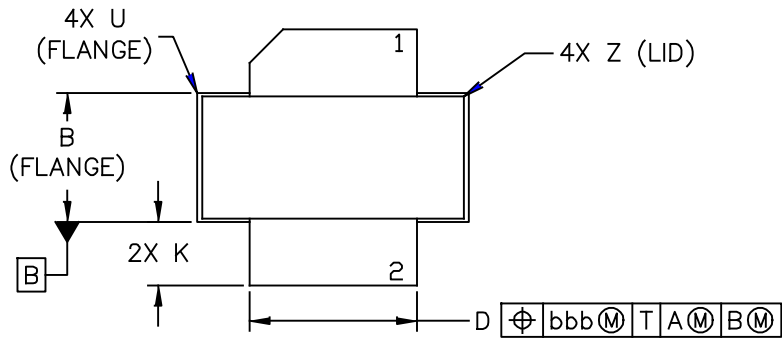
NOTES:

1. CONTROLLING DIMENSION: INCH.
2. INTERPRET DIMENSIONS AND TOLERANCES PER ASME Y14.5M-1994.

3. DIMENSIONS H1 AND H2 ARE MEASURED .030 INCH (0.762 MM) AWAY FROM FLANGE PARALLEL TO DATUM B. H1 APPLIES TO PINS 1 & 3. H2 APPLIES TO PINS 2 & 4.

4. TOLERANCE OF DIMENSION H2 IS TENTATIVE AND COULD CHANGE ONCE SUFFICIENT MANUFACTURING DATA IS AVAILABLE.

DIM	INCH		MILLIMETER		DIM	INCH		MILLIMETER	
	MIN	MAX	MIN	MAX		MIN	MAX	MIN	MAX
AA	.805	– .815	20.45	– 20.70	R	.365	– .375	9.27	– 9.53
BB	.380	– .390	9.65	– 9.91	S	.365	– .375	9.27	– 9.53
CC	.125	– .170	3.18	– 4.32	U	.035	– .045	0.89	– 1.14
D	.495	– .505	12.57	– 12.83	V1	.795	– .805	20.19	– 20.45
E	.035	– .045	0.89	– 1.14	W1	.080	– .090	2.03	– 2.29
F	.004	– .007	0.10	– 0.18	W2	.155	– .165	3.94	– 4.19
H1	.057	– .067	1.45	– 1.70	W3	.210	– .220	5.33	– 5.59
H2	.054	– .070	1.37	– 1.78	Y	.956 BSC		24.28 BSC	
K	.170	– .210	4.32	– 5.33	Z	R.000 – R.040		R0.00 – R1.02	
M	.774	– .786	19.66	– 19.96	aaa	– .005	–	– 0.13	–
N	.772	– .788	19.61	– 20.02	bbb	– .010	–	– 0.25	–
					ccc	– .015	–	– 0.38	–
© FREESCALE SEMICONDUCTOR, INC. ALL RIGHTS RESERVED.			MECHANICAL OUTLINE			PRINT VERSION NOT TO SCALE			
TITLE:  NI-780-2S2L					DOCUMENT NO: 98ASA00517D      REV: A				
					STANDARD: NON-JEDEC				
					08 MAR 2013				



© FREESCALE SEMICONDUCTOR, INC. ALL RIGHTS RESERVED.		MECHANICAL OUTLINE		PRINT VERSION NOT TO SCALE	
TITLE:  NI-780S		DOCUMENT NO: 98ASB16718C		REV: H	
		CASE NUMBER: 465A-06		31 MAR 2005	
		STANDARD: NON-JEDEC			

NOTES:

1. DIMENSIONING AND TOLERANCING PER ANSI Y14.5M-1994.
2. CONTROLLING DIMENSION: INCH.
3. DELETED
4. DIMENSION H IS MEASURED .030 (0.762) AWAY FROM PACKAGE BODY.

STYLE 1:

- PIN 1. DRAIN
2. GATE
3. SOURCE

DIM	INCH		MILLIMETER		DIM	INCH		MILLIMETER	
	MIN	MAX	MIN	MAX		MIN	MAX	MIN	MAX
A	.805	– .815	20.45	– 20.7	U	–	– .040	–	– 1.02
B	.380	– .390	9.65	– 9.91	Z	–	– .030	–	– 0.76
C	.125	– .170	3.18	– 4.32	aaa	–	.005 –	–	0.127 –
D	.495	– .505	12.57	– 12.83	bbb	–	.010 –	–	0.254 –
E	.035	– .045	0.89	– 1.14	ccc	–	.015 –	–	0.381 –
F	.003	– .006	0.08	– 0.15	–	–	– –	–	– –
H	.057	– .067	1.45	– 1.7	–	–	– –	–	– –
K	.170	– .210	4.32	– 5.33	–	–	– –	–	– –
M	.774	– .786	19.61	– 20.02	–	–	– –	–	– –
N	.772	– .788	19.61	– 20.02	–	–	– –	–	– –
R	.365	– .375	9.27	– 9.53	–	–	– –	–	– –
S	.365	– .375	9.27	– 9.52	–	–	– –	–	– –

© FREESCALE SEMICONDUCTOR, INC. ALL RIGHTS RESERVED.	MECHANICAL OUTLINE	PRINT VERSION NOT TO SCALE
TITLE:  NI-780S	DOCUMENT NO: 98ASB16718C CASE NUMBER: 465A-06 STANDARD: NON-JEDEC	REV: H 31 MAR 2005

Refer to the following documents, software and tools to aid your design process.

**Application Notes**

- AN1955: Thermal Measurement Methodology of RF Power Amplifiers

**Engineering Bulletins**

- EB212: Using Data Sheet Impedances for RF LDMOS Devices

**Software**

- Electromigration MTTF Calculator
- RF High Power Model
- .s2p File

**Development Tools**

- Printed Circuit Boards

For Software and Tools, do a Part Number search at <http://www.freescale.com>, and select the “Part Number” link. Go to the Software & Tools tab on the part’s Product Summary page to download the respective tool.

**R5 TAPE AND REEL OPTION**

NI-780S-2L4S: R5 Suffix = 50 Units, 44 mm Tape Width, 13-inch Reel.

NI-780S-2L: R5 Suffix = 50 Units, 56 mm Tape Width, 13-inch Reel.

The R5 tape and reel option for AFT21S230S and AFT21S232S parts will be available for 2 years after release of AFT21S230S and AFT21S232S. Freescale Semiconductor, Inc. reserves the right to limit the quantities that will be delivered in the R5 tape and reel option. At the end of the 2 year period customers who have purchased this device in the R5 tape and reel option will be offered AFT21S230S and AFT21S232S in the R3 tape and reel option.

**REVISION HISTORY**

The following table summarizes revisions to this document.

Revision	Date	Description
0	Oct. 2012	• Initial Release of Data Sheet
1	Nov. 2012	• Corrected Tape and Reel tape width from 32 mm to 44 mm, pp. 1, 17
2	Mar. 2013	<ul style="list-style-type: none"> <li>• Table 1. Maximum Ratings, CW Operation for drain lead: changed CW Operation @ <math>T_C = 25^\circ\text{C}</math> from 163 W to 161 W and changed derate factor from 0.79 W/<math>^\circ\text{C}</math> to 0.75 W/<math>^\circ\text{C}</math> to reflect recent thermal measurement test results of the AFT21S230S and AFT21S232S parts, p. 2</li> <li>• Table 1. Maximum Ratings: added CW Operation rating and derate factor if the AFT21S230S part is biased through pin 4 and pin 6, p. 2</li> <li>• Table 4. Load Mismatch: added footnote 2, indicating CW output power and CW rated power exceed recommended operating conditions, p. 3</li> </ul>
3	Mar. 2014	<ul style="list-style-type: none"> <li>• Added part number AFT21S230-12SR3, p. 1</li> <li>• Added NI-780S-2L2L package isometric, p. 1, and Mechanical Outline, pp. 12-13</li> <li>• Added Fig. 2, Pin Connections drawing for AFT21S230-12SR3 and VBW lead DC feed connections footnote for AFT21S230SR3 and AFT21S230-12SR3, p. 1</li> <li>• Maximum Ratings table, CW operation: added AFT21S230-12S part to VBW lead DC feed condition information, pp. 2-3</li> <li>• Table 5, Test Circuit Component Designations and Values: updated PCB description to reflect most current board specifications from Rogers, p. 4</li> </ul>

### ***How to Reach Us:***

**Home Page:**  
[freescale.com](http://freescale.com)

**Web Support:**  
[freescale.com/support](http://freescale.com/support)

Information in this document is provided solely to enable system and software implementers to use Freescale products. There are no express or implied copyright licenses granted hereunder to design or fabricate any integrated circuits based on the information in this document.

Freescale reserves the right to make changes without further notice to any products herein. Freescale makes no warranty, representation, or guarantee regarding the suitability of its products for any particular purpose, nor does Freescale assume any liability arising out of the application or use of any product or circuit, and specifically disclaims any and all liability, including without limitation consequential or incidental damages. "Typical" parameters that may be provided in Freescale data sheets and/or specifications can and do vary in different applications, and actual performance may vary over time. All operating parameters, including "typicals," must be validated for each customer application by customer's technical experts. Freescale does not convey any license under its patent rights nor the rights of others. Freescale sells products pursuant to standard terms and conditions of sale, which can be found at the following address: [freescale.com/SalesTermsandConditions](http://freescale.com/SalesTermsandConditions).

Freescale and the Freescale logo are trademarks of Freescale Semiconductor, Inc., Reg. U.S. Pat. & Tm. Off. Airfast is a trademark of Freescale Semiconductor, Inc. All other product or service names are the property of their respective owners.  
© 2012–2014 Freescale Semiconductor, Inc.

## Looking for pricing, stock, or lifecycle information?

Click below to explore more details on WIN SOURCE:

 [View AFT21S230SR5 on WIN SOURCE](#)

 [NXP / Nexperia Information](#)

## Optimize Your Supply Chain with WIN SOURCE Solutions

-  Global Sourcing Solution
-  Obsolete Management
-  Cost Control Management
-  Shortage Management
-  Alternative Solution
-  Excess Inventory Management