



AK5397

32-Bit Stereo Premium ADC

1. General Description

The AK5397 is a high performance 32-bit stereo ADC that achieves class leading performance of 127dB dynamic range for stereo output. This is a flagship addition to AKM's VERITA series of product in the Audio 4 Pro™ family. The AK5397 integrates a newly developed circuit by VELVET SOUND™ technology achieving rich sound field and bass representation that realizes a music playback experience with less distortion. The

class leading performance with a maximum 768kHz PCM output is supported for digital output and newly developed 32-bit digital filters are integrated for the best sound quality. The AK5397 is suitable for digital video recorders and high quality sound studio mixers for recording and editing high-resolution sound sources.

2. Features

- Advanced multi bit Architecture ADC
- Resolution: 32bit
- Sampling Rate: 8kHz ~ 768kHz
- Full Differential Inputs
- S/(N+D): 108dB
- DR, S/N: 127dB (Mono Mode: 130dB)
- Sharp Roll Off Digital Filter (GD=41.5/fs)
 - ▶ Passband: 0 ~ 21.82kHz (@ fs=48kHz)
 - ▶ Passband Ripple: +0.00010/-0.00015dB
 - ▶ Stopband Attenuation: 100dB
- Short Delay Digital Filter (GD=12.5/fs)
 - ▶ Passband: 0 ~ 22.22kHz (@ fs=48kHz)
 - ▶ Passband Ripple: +0.055/-0.015dB
 - ▶ Stopband Attenuation: 93dB
- Minimum Phase Digital Filter (GD=3.5/fs)
 - ▶ Passband: 0 ~ 21.75kHz(@ fs=48kHz)
 - ▶ Passband Ripple: +0.04/-0.02dB
 - ▶ Stopband Attenuation: 93dB
- Master / Slave Mode
- Master Clock:
 - ▶ 256fs/512fs (Normal Speed; 8kHz~48kHz)
 - ▶ 256fs (Double Speed; 48Hz ~ 96kHz)
 - ▶ 128fs (Quad Speed; 96kHz ~ 192kHz)
 - ▶ 64fs (Octal Speed; 192kHz ~ 384kHz)
 - ▶ 32fs (Hex Speed; 384kHz ~ 768kHz)
- Audio Interface Format: 32bit MSB justified, I2S compatible or TDM
- Cascade TDM I/F: 8ch/48kHz, 4ch/96kHz, 4ch/192kHz
- Digital HPF for Offset Cancel
- Overflow Flag
- Power Supply:
 - ▶ 4.75 ~ 5.25V(Analog), 3.0 ~ 3.6V(Digital)
- Power Dissipation: 455mW
- Ta = -10 ~ 70 °C
- Package: 44-pin LQFP

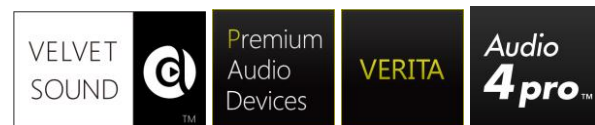

3. Block Diagram

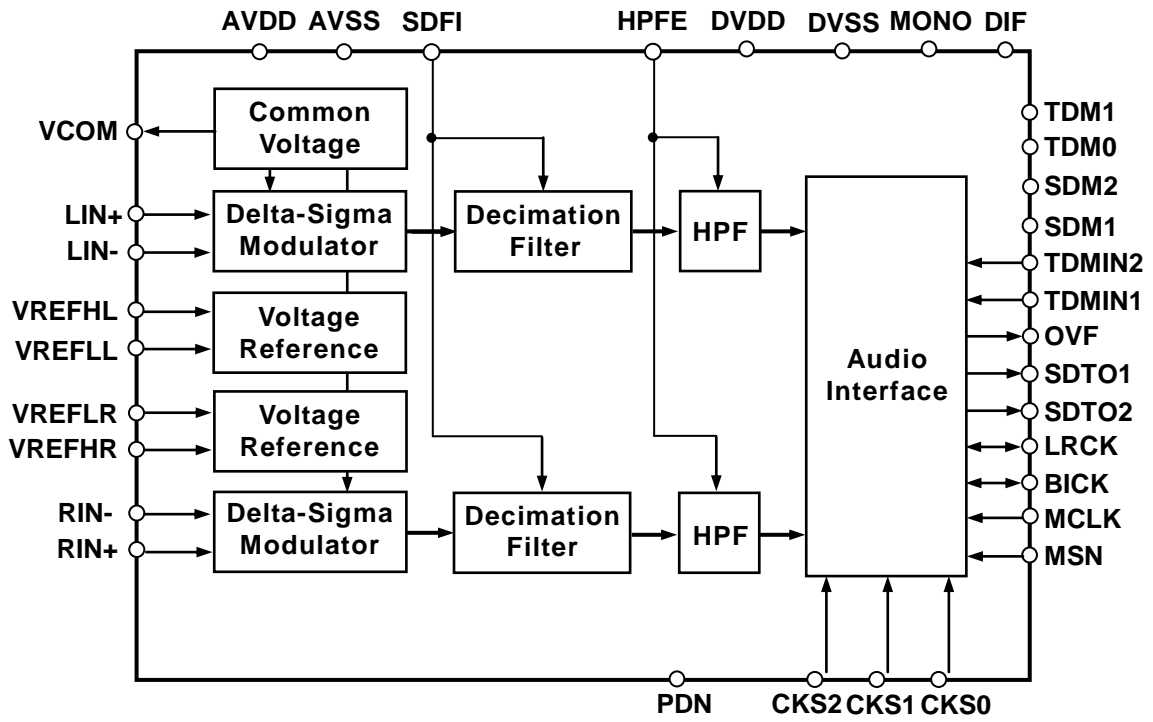

Figure 1. Block Diagram

4. Table of Contents

1.	General Description	1
2.	Features	1
3.	Block Diagram	2
4.	Table of Contents	3
5.	Pin Configurations and Functions	4
■	Pin Configurations	4
■	Functions	5
■	Handling of Unused Pin	6
6.	Absolute Maximum Ratings	7
7.	Recommended Operating Conditions	7
8.	Electrical Characteristics	8
■	Analog Characteristics	8
■	Sharp Roll-Off Filter Characteristics	9
■	Short Delay Filter Characteristics	11
■	Minimum Phase Filter Characteristics	12
■	Digital Filter Plot	14
■	DC Characteristics	18
■	Switching Characteristics	18
■	Timing Diagrams	21
9.	Functional Descriptions	23
■	System Clock	23
■	Master Mode/Slave Mode	24
■	Audio Interface Format	25
■	Cascade TDM Mode	29
■	Digital High Pass Filter	33
■	Overflow Detection	33
■	Mono Mode	33
■	Digital Output Data	34
■	Power Down & Reset	36
10.	SYSTEM DESIGN	37
11.	PACKAGE	41
■	Outline Dimensions	41
■	Material & Lead finish	42
■	MARKING	42
12.	Ordering Guide	42
13.	Revision History	43
	IMPORTANT NOTICE	44

5. Pin Configurations and Functions

■ Pin Configurations

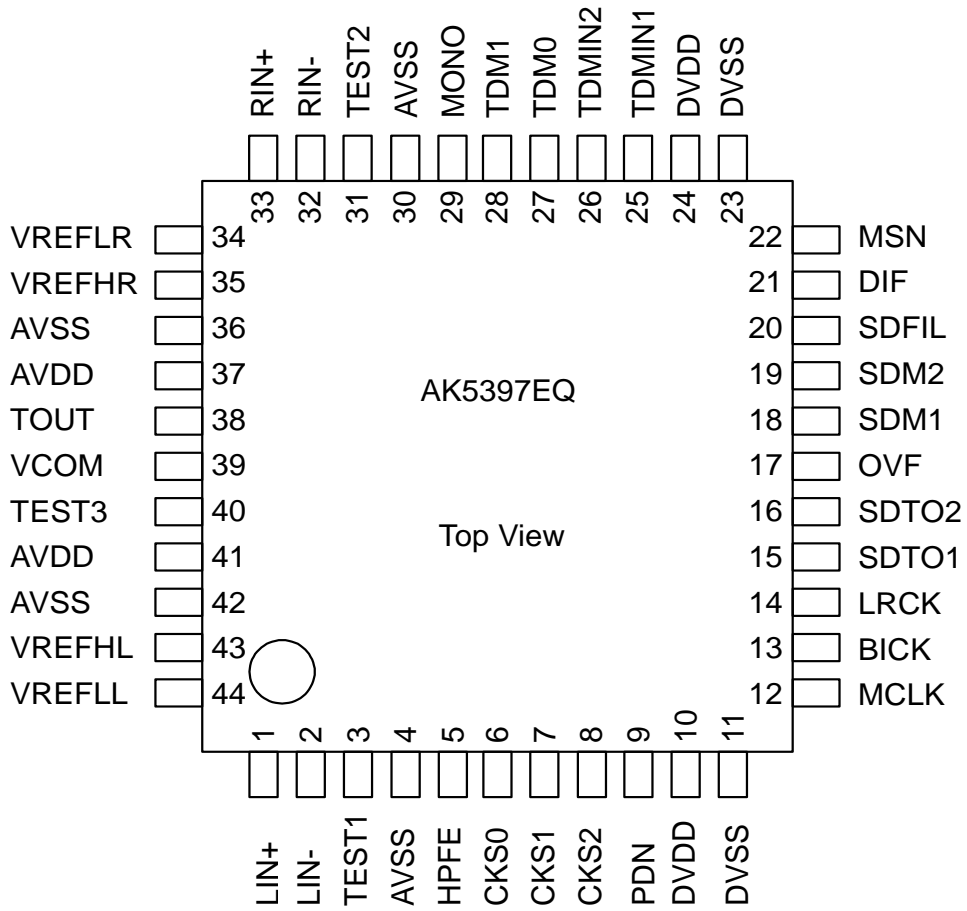

Figure 2. Pin Configurations

■ Functions

No.	Pin Name	Power	I/O	Function
1	LIN+	A	I	Lch Positive Analog Input Pin
2	LIN-	A	I	Lch Negative Analog Input Pin
3	TEST1	A	-	Test Pin This pin must be connected to AVSS.
4	AVSS	A	-	Analog Ground Pin, 0V
5	HPFE	D	I	HPF Enable Pin “L”: Disable, “H” Enable
6	CKS0	D	I	Clock Mode Select #0 Pin
7	CKS1	D	I	Clock Mode Select #1 Pin
8	CKS2	D	I	Clock Mode Select #2 Pin
9	PDN	D	I	Power down & Reset pin “L”: All blocks are powered-down and reset. “H”: Normal Operation
10	DVDD	D	-	Digital Power Supply Pin, 3.0V ~ 3.6V
11	DVSS	D	-	Digital Ground Pin, 0V
12	MCLK	D	I	Master Clock Input Pin
13	BICK	D	I/O	Serial Data Clock Pin When PDN pin = “L”, BICK outputs “L” in master mode.
14	LRCK	D	I/O	L/R Channel Select Clock Pin When PDN pin = “L”, LRCK outputs “L” in master mode.
15	SDTO1	D	O	Serial Data Output #1 Pin (Sharp Roll Off Filter Output) When PDN pin = “L”, SDTO1 outputs “L”.
16	SDTO2	D	O	Serial Data Output #2 Pin (Short Delay or Minimum Phase Filter Output) When PDN pin = “L”, SDTO2 outputs “L”.
17	OVF	D	O	Analog Input Overflow Detect Pin This pin goes to “H” if any analog inputs overflows When the PDN pin = “L”, the OVF pin outputs “L”.
18	SDM1	D	I	SDTO1 Output Mute Pin This function is synchronized with LRCK edges. “L”: Normal Operation, “H”: “L” output
19	SDM2	D	I	SDTO2 Output Mute Pin This function is synchronized with LRCK edges. “L”: Normal Operation, “H”: “L” output
20	SDFIL	D	I	SDTO2 Digital Filter Select Pin “L”: Short Delay, “H”: Minimum Phase
21	DIF	D	I	Audio Interface Format Pin “L”: 32bit MSB justified, “H”: 32bit I ² S Compatible
22	MSN	D	I	Master/Slave mode Select Pin “L”: Slave mode, “H”: Master mode
23	DVSS	D	-	Digital Ground Pin, 0V
24	DVDD	D	-	Digital Power Supply Pin, 3.0 ~ 3.6V
25	TDMIN1	D	I	TDM Data Input #1 Pin
26	TDMIN2	D	I	TDM Data Input #2 Pin
27	TDM0	D	I	TDM I/F Format Enable Pin “L”: Normal Mode, “H”: TDM Mode
28	TDM1	D	I	TDM I/F BICK Frequency Select Pin “L”: 256fs, “H”: 128fs

No.	Pin Name	Power	I/O	Function
29	MONO	D	I	Stereo/Mono mode Select Pin "L": Stereo mode, "H": Mono mode
30	AVSS	A	-	Analog Ground Pin, 0V
31	TEST2	A	I	Test Pin This pin must be connected to AVSS.
32	RIN-	A	I	Rch Negative Analog Input Pin
33	RIN+	A	I	Rch Positive Analog Input Pin
34	VREFLR	A	I	Rch Negative Reference Voltage Input Pin Normally connected to AVSS.
35	VREFHR	A	I	Rch Positive Reference Voltage Input Pin, 4.75 ~ 5.25V Normally connected to the VREFLR pin with a large electrolytic capacitor and a 0.1μF ceramic capacitor.
36	AVSS	A	-	Analog Ground Pin, 0V
37	AVDD1	A	-	Analog Power Supply Pin, 4.75 ~ 5.25V
38	TOUT	A	I	TEST Pin This pin must be Connected to AVSS.
39	VCOM	A	O	Common Voltage Output Pin, AVDD/2 Normally connected to AVSS with a 0.1μF ceramic capacitor in parallel with a 10μF electrolytic capacitor.
40	TEST3	A	I	Test Pin This pin must be connected to AVSS.
41	AVDD2	A	-	Analog Power Supply Pin, 4.75 ~ 5.25V
42	AVSS	A	-	Analog Ground Pin, 0V
43	VREFHL	A	I	Lch Positive Reference Voltage Input Pin, 4.75 ~ 5.25V Normally connected to the VREFLL pin with a large electrolytic capacitor and a 0.1μF ceramic capacitor.
44	VREFLL	A	I	Lch Negative Reference Voltage Input Pin Normally connected to AVSS.

Note 1. All digital input pins must not be left floating.

■ Handling of Unused Pin

The unused I/O pin must be processed as below.

Classification	Pin Name	Setting
Digital	TEST1/2/3, TOUT	This pin must be connected to AVSS.
	TDMIN1/2	This pin must be connected to DVSS.
	SDTO1, SDTO2, OVF	This pin must be open.
Analog	LIN+, LIN-	Connect the LIN+ pin and the LIN- pin.
	RIN+, RIN-	Connect the RIN+ pin and the RIN- pin.

6. Absolute Maximum Ratings

(AVSS=DVSS=0V; [Note 2](#))

Parameter		Symbol	Min.	Max.	Unit
Power Supplies:	Analog	AVDD	-0.3	6.0	V
	Digital	DVDD	-0.3	4.6	V
	AVSS-DVSS (Note 3)	ΔGND1	-	0.3	V
Input Current, Any Pin Except Supplies		IIN	-	±10	mA
Analog Input Voltage (Note 4)		VINA	-0.3	AVDD+0.3	V
Digital Input Voltage (Note 5)		VIND	-0.3	DVDD+0.3	V
Ambient Temperature (power applied)		Ta	-10	70	°C
Storage Temperature		Tstg	-65	150	°C

Note 2. All voltages with respect to ground.

Note 3. AVSS and DVSS must be connected to the same analog ground plane.

Note 4. VREFHL, VREFLL, VREFHR, VREFLR, LIN+, LIN-, RIN+, RIN-, TEST1-3 and TOUT pins.

Note 5. CKS0, CKS1, CKS2, PDN, SDM1, SDM2, SDFIL, TDMIN1, TDMIN2, MCLK, BICK, LRCK, DIF, MSN, HPFE, MONO, TDM0, TDM1pins

WARNING: Operation at or beyond these limits may result in permanent damage to the device.
Normal operation is not guaranteed at these extremes.

7. Recommended Operating Conditions

(AVSS=DVSS=0V; [Note 2](#))

Parameter		Symbol	Min.	Typ.	Max.	Unit
Power Supplies: (Note 6)	Analog	AVDD	4.75	5.0	5.25	V
	Digital	DVDD	3.0	3.3	3.6	V
Voltage Reference (Note 9)	“H” voltage reference (Note 7)	VREFHL/R	AVDD-0.5	-	AVDD	V
	“L” voltage reference (Note 8)	VREFLL/R	-	AVSS	-	V
	(VREFHL/R) – (VREFLL/R)	ΔVREF	AVDD-0.5	-	AVDD	V

Note 2. All voltages with respect to ground.

Note 6. AVDD and DVDD are powered up simultaneously.

Note 7. VREFHL pin, VREFHR pin

Note 8. VREFLL pin, VREFLR pin

Note 9. VREFLL and VREFLR pins must be connected to AVSS.

Analog input voltage scales with voltage of {(VREFH) – (VREFL)}.

$$V_{in} (\text{typ.}) = \pm 2.8 \times \{(VREFH) - (VREFL)\} / 5 \text{ [V]}$$

WARNING: AKM assumes no responsibility for the usage beyond the conditions in this datasheet.

8. Electrical Characteristics

■ Analog Characteristics

(Ta = 25°C; AVDD=5.0V; DVDD=3.3V; AVSS=DVSS=0V; VREFHL=VREFHR=AVDD, VREFLL=VREFLR=AVSS; fs=48kHz, 96kHz, 192kHz; BICK=64fs; Signal Frequency=1kHz; 32bit Data; Measurement frequency=10Hz~20kHz at fs=48kHz, 40Hz~40kHz at fs=96kHz, 80Hz~80kHz at fs=192kHz; External circuit: [Figure 41](#) "Analog input buffer circuit example 2"; unless otherwise specified)

Parameter		Min.	Typ.	Max.	Unit
Resolution				32	Bits
Analog Input Characteristics:					
S/(N+D)	fs=48kHz BW=20kHz	-1dBFS	92	100	dB
		-1dBFS (Note 10)	-	108	
		-2dBFS (Note 10)	-	110	
		-20dBFS	-	102	
		-60dBFS	-	64	
	fs=96kHz BW=40kHz	-1dBFS	92	99	dB
		-1dBFS (Note 10)	-	107	
		-20dBFS	-	99	
		-60dBFS	-	60	
	fs=192kHz BW=80kHz	-1dBFS	91	99	dB
		-1dBFS (Note 10)	-	106	
		-20dBFS	-	94	
		-60dBFS	-	54	
Dynamic Range (-60dBFS with A-weighted)					
(Stereo Mode)		122	127		dB
(Mono Mode)		125	130		dB
S/N (A-weighted) fs=48kHz					
(Stereo Mode)		122	127		dB
(Mono Mode)		125	130		dB
S/N (Without A-weighted) fs=96kHz					
(Stereo Mode)		115	120		dB
S/N (Without A-weighted) fs=192kHz					
(Stereo Mode)		111	116		dB
Input Resistance		650	720		Ω
Interchannel Isolation		120	130		dB
Interchannel Gain Mismatch			0.1	0.5	dB
Gain Drift			150		ppm/°C
Input Voltage (Note 11)		±2.6	±2.8	±3.0	Vpp
Input DC Bias Voltage			0.382 × AVDD		Vpp
Power Supplies:					
Power Supply Current					
AVDD + VREFHL + VREFHR			74.6	94.0	mA
DVDD (fs=48kHz, MSN=H, SDM1=L, SDM2=H)			24	33	mA
(fs=96kHz, MSN=H, SDM1=L, SDM2=L)			52	71	mA
(fs=192kHz, MSN=H, SDM1=L, SDM2=L)			53	72	mA
(fs=384kHz, MSN=H, SDM1=L, SDM2=L)			34	46	mA
(fs=768kHz, MSN=H, SDM1=L, SDM2=L)			34	46	mA
Power down current (AVDD + DVDD)			10	100	uA
Power Supply Rejection (Note 12)		-	50	-	dB

Note 10. Using the circuit as shown in [Figure 40](#)(Analog input buffer circuit example 1)

Note 11. This value is (LIN+) – (LIN-) and (RIN+) - (RIN-). Input voltage is proportional to a difference between VREFP and VREFL voltages.

$$V_{in} (\text{typ.}) = \pm 2.8 \times \{(VREFH) - (VREFL)\} / 5 [V]$$

Note 12. PSRR is applied to AVDD and DVDD with 1kHz, 20mVpp. The VREFHL/R and VREFLL/R pins held a constant voltage.

■ Sharp Roll-Off Filter Characteristics

(1) Sharp Roll-Off Filter Characteristics (fs=48kHz)

(Ta=25°C; AVDD=4.75~5.25V; DVDD=3.0~3.6V; fs=48kHz)

Parameter	Symbol	Min.	Typ.	Max.	Unit	
ADC Digital Filter (Decimation LPF):						
Passband (Note 13) Figure 3-(1)	PB	0		21.82	kHz	
Passband Ripple (Note 14) Figure 3-(3)	PR	-0.00015		+0.00010	dB	
Frequency Response (Note 14)	FR	-0.001dB	-	21.93	-	kHz
		-0.1dB	-	22.54	-	kHz
		-3.0dB	-	23.62	-	kHz
		-6.0dB	-	23.99	-	kHz
Stopband (Note 14) Figure 3-(2)	SB	26.17		3072	kHz	
Stopband Attenuation Figure 3-(4)	SA	100			dB	
Group Delay Distortion	ΔGD		0		1/fs	
Group Delay (Note 15)	GD		41.5		1/fs	
ADC Digital Filter (HPF):						
Frequency response (Note 14)	FR	-3dB	-	0.93	-	Hz
		-0.1dB	-	6.1	-	Hz

(2) Sharp Roll-Off Filter Characteristics (fs=96kHz)

(Ta=25°C; AVDD=4.75~5.25V; DVDD=3.0~3.6V; fs=96kHz)

Parameter	Symbol	Min.	Typ.	Max.	Unit	
ADC Digital Filter (Decimation LPF):						
Passband (Note 13) Figure 4-(1)	PB	0		43.62	kHz	
Pass Band Ripple (Note 14) Figure 4-(3)	PR	-0.00015		+0.00015	dB	
Frequency Response (Note 14)	FR	-0.001dB	-	43.87	-	kHz
		-0.1dB	-	45.10	-	kHz
		-3.0dB	-	47.25	-	kHz
		-6.0dB	-	47.99	-	kHz
Stopband (Note 14) Figure 4-(2)	SB	52.36		3072	kHz	
Stopband Attenuation Figure 4-(4)	SA	100			dB	
Group Delay Distortion	ΔGD		0		1/fs	
Group Delay (Note 15)	GD		41.4		1/fs	
ADC Digital Filter (HPF):						
Frequency response (Note 14)	FR	-3dB	-	0.93	-	Hz
		-0.1dB	-	6.1	-	Hz

(3) Sharp Roll-Off Filter Characteristics (fs=192kHz)
 (Ta=25°C; AVDD=4.75~5.25V; DVDD=3.0~3.6V; fs=192kHz)

Parameter		Symbol	Min.	Typ.	Max.	Unit
ADC Digital Filter (Decimation LPF):						
Passband	(Note 13) Figure 5-(1)	PB	0		87.32	kHz
PassBand Ripple	(Note 14) Figure 5-(2)	PR	-0.005		+0.006	dB
Frequency Response (Note 14)	-0.1dB	FR	-	89.52	-	kHz
	-3.0dB		-	94.33	-	kHz
	-6.0dB		-	95.97	-	kHz
Stopband	(Note 14) Figure 5-(3)	SB	105.60		3072	kHz
Stopband Attenuation	Figure 5-(4)	SA	100			dB
Group Delay Distortion		ΔGD		0		1/fs
Group Delay	(Note 15)	GD		36.3		1/fs
ADC Digital Filter (HPF):						
Frequency response (Note 14)	-3dB	FR	-	0.93	-	Hz
	-0.1dB		-	6.1	-	Hz

(4) Sharp Roll-Off Filter Characteristics (fs=384kHz)
 (Ta=25°C; AVDD=4.75~5.25V; DVDD=3.0~3.6V; fs=384kHz)

Parameter		Symbol	Min.	Typ.	Max.	Unit
ADC Digital Filter (Decimation LPF):						
Frequency Response (Note 14)	-0.1dB	FR	0	60.67	-	kHz
	-1.0B		-	86.93	-	kHz
	-3.0dB		-	107.70	-	kHz
	-6.0dB		-	125.30	-	kHz
Stopband	(Note 14) Figure 6-(1)	SB	223.93		3072	kHz
Stopband Attenuation	Figure 6-(2)	SA	83			dB
Group Delay Distortion		ΔGD		0		1/fs
Group Delay	(Note 15)	GD		10.6		1/fs

(5) Sharp Roll-Off Filter Characteristics (fs=768kHz)
 (Ta=25°C; AVDD=4.75~5.25V; DVDD=3.0~3.6V; fs=768kHz)

Parameter		Symbol	Min.	Typ.	Max.	Unit
ADC Digital Filter (Decimation LPF):						
Frequency Response (Note 14)	-0.1dB	FR	0	34.01	-	kHz
	-1.0dB		-	101.51	-	kHz
	-3.0dB		-	163.13	-	kHz
	-6.0dB		-	216.16	-	kHz
Stopband	(Note 14) Figure 7-(1)		533.42		3072	KHz
Stopband Attenuation	Figure 7-(2)		85			dB
Group Delay Distortion		ΔGD		0		1/fs
Group Delay	(Note 15)	GD		8.4		1/fs

Note 13. The definition of Passband is applied to the frequency which is within the limits of Passband Ripple.

Note 14. The passband and stopband frequencies scales with fs. The reference frequency of these responses is 1kHz.

Note 15. The calculated delay time induced by digital filtering. This time is from the input of an analog signal to the setting of 32bit data both of channels to the ADC output register for ADC.

■ Short Delay Filter Characteristics

(1) Short Delay Filter Characteristics (fs=48kHz)

(Ta=25°C; AVDD=4.75~5.25V; DVDD=3.0~3.6V; fs=48kHz; SDFIL="L")

Parameter		Symbol	Min.	Typ.	Max.	Unit
ADC Digital Filter (Decimation LPF):						
Passband	(Note 13) Figure 8-(1)	PB	0		22.22	kHz
Passband Ripple	(Note 14) Figure 8-(2)	PR	-0.015		+0.055	dB
Frequency Response (Note 14)	-0.1dB	FR	-	22.40	-	kHz
	-3.0dB		-	23.70	-	kHz
	-6.0dB		-	24.28	-	kHz
Stopband	(Note 14) Figure 8-(3)	SB	27.93		3072	kHz
Stopband Attenuation	Figure 8-(4)	SA	93			dB
Group Delay Distortion		ΔGD			±0.1	1/fs
Group Delay	(Note 15)	GD		12.5		1/fs
ADC Digital Filter (HPF):						
Frequency response (Note 14)	-3dB	FR	-	0.93	-	Hz
	-0.1dB		-	6.1	-	Hz

(2) Short Delay Filter Characteristics (fs=96kHz)

(Ta=25°C; AVDD=4.75~5.25V; DVDD=3.0~3.6V; fs=96kHz; SDFIL="L")

Parameter		Symbol	Min.	Typ.	Max.	Unit
ADC Digital Filter (Decimation LPF):						
Passband	(Note 13) Figure 9-(1)	PB	0		44.46	kHz
Passband Ripple	(Note 14) Figure 9-(2)	PR	-0.05		+0.02	dB
Frequency Response (Note 14)	-0.1dB	FR	-	44.68	-	kHz
	-3.0dB		-	47.40	-	kHz
	-6.0dB		-	48.56	-	kHz
Stopband	(Note 14) Figure 9-(3)	SB	55.90		3072	kHz
Stopband Attenuation	Figure 9-(4)	SA	93			dB
Group Delay Distortion		ΔGD			±0.075	1/fs
Group Delay	(Note 15)	GD		12.4		1/fs
ADC Digital Filter (HPF):						
Frequency response (Note 14)	-3dB	FR	-	0.93	-	Hz
	-0.1dB		-	6.1	-	Hz

(3) Short Delay Filter Characteristics (fs=192kHz)

(Ta=25°C; AVDD=4.75~5.25V; DVDD=3.0~3.6V; fs=192kHz; SDFIL="L")

Parameter		Symbol	Min.	Typ.	Max.	Unit
ADC Digital Filter (Decimation LPF):						
Passband	(Note 13) Figure 10-(1)	PB	0		80.71	kHz
Passband Ripple	(Note 14) Figure 10-(2)	PR	-0.05		+0.02	dB
Frequency Response (Note 14)	-0.1dB	PB	-	82.5	-	kHz
	-3.0dB		-	92.86	-	kHz
	-6.0dB		-	96.31	-	kHz
Stopband	(Note 14) Figure 10-(3)	SB	116.67		3072	kHz
Stopband Attenuation	Figure 10-(4)	SA	93			dB
Group Delay Distortion		ΔGD			±0.02	1/fs
Group Delay	(Note 15)	GD		12.2		1/fs
ADC Digital Filter (HPF):						
Frequency response (Note 14)	-3dB	FR	-	0.93	-	Hz
	-0.1dB		-	6.1	-	Hz

Note 13. The definition of Passband is applied to the frequency which is within the limits of Passband Ripple.

Note 14. The passband and stopband frequencies scales with fs. The reference frequency of these responses is 1kHz.

Note 15. The calculated delay time induced by digital filtering. This time is from the input of an analog signal to the setting of 32bit data both of channels to the ADC output register for ADC.

■ Minimum Phase Filter Characteristics

(1) Minimum Phase Filter Characteristics (fs=48kHz)

(Ta=25°C; AVDD=4.75~5.25V; DVDD=3.0~3.6V; fs=48kHz; SDFIL="H")

Parameter		Symbol	Min.	Typ.	Max.	Unit
ADC Digital Filter (Decimation LPF):						
Passband	(Note 13) Figure 11-(1)	PB	0		21.75	kHz
Passband Ripple	(Note 14) Figure 11-(2)	PR	-0.02		+0.04	dB
Frequency Response (Note 14)	-0.1dB	FR	-	21.97	-	kHz
	-3.0dB		-	23.49	-	kHz
	-6.0dB		-	24.12	-	kHz
Stopband	(Note 14) Figure 11-(3)	SB	27.97		3072	kHz
Stopband Attenuation	Figure 11-(4)	SA	93			dB
Group Delay Distortion		ΔGD			±1.5	1/fs
Group Delay	(Note 15)	GD		3.5		1/fs
ADC Digital Filter (HPF):						
Frequency response (Note 14)	-3dB	FR	-	0.93	-	Hz
	-0.1dB		-	6.1	-	Hz

(2) Minimum Phase Filter Characteristics (fs=96kHz)

(Ta=25°C; AVDD=4.75~5.25V; DVDD=3.0~3.6V; fs=96kHz; SDFIL="H")

Parameter		Symbol	Min.	Typ.	Max.	Unit
ADC Digital Filter (Decimation LPF):						
Passband	(Note 13) Figure 12-(1)	PB	0		43.55	kHz
Passband Ripple	(Note 14) Figure 12-(2)	PR	-0.04		+0.02	dB
Frequency Response (Note 14)	-0.1dB	FR	-	43.87	-	kHz
	-3.0dB		-	46.98	-	kHz
	-6.0dB		-	48.26	-	kHz
Stopband	(Note 14) Figure 12-(3)	SB	55.96		3072	kHz
Stopband Attenuation	Figure 12-(4)	SA	93			dB
Group Delay Distortion		ΔGD			±1.5	1/fs
Group Delay	(Note 15)	GD		3.4		1/fs
ADC Digital Filter (HPF):						
Frequency response (Note 14)	-3dB	FR	-	0.93	-	Hz
	-0.1dB		-	6.1	-	Hz

(3) Minimum Phase Filter Characteristics (fs=192kHz)

(Ta=25°C; AVDD=4.75~5.25V; DVDD=3.0~3.6V; fs=192kHz; SDFIL="H")

Parameter		Symbol	Min.	Typ.	Max.	Unit
ADC Digital Filter (Decimation LPF):						
Passband	(Note 13) Figure 13-(1)	PB	0		80.97	kHz
Passband Ripple	(Note 14) Figure 13-(2)	PR	-0.045		+0.015	dB
Frequency Response (Note 14)	-0.1dB	FR	-	82.55	-	kHz
	-3.0dB		-	92.02	-	kHz
	-6.0dB		-	95.44	-	kHz
Stopband	(Note 14) Figure 13-(3)	SB	115.57		3072	kHz
Stopband Attenuation	Figure 13-(4)	SA	93			dB
Group Delay Distortion		ΔGD			±1.6	1/fs
Group Delay	(Note 15)	GD		4.2		1/fs
ADC Digital Filter (HPF):						
Frequency response (Note 14)	-3dB	FR	-	0.93	-	Hz
	-0.1dB		-	6.1	-	Hz

Note 13. The definition of Passband is applied to the frequency which is within the limits of Passband Ripple.

Note 14. The passband and stopband frequencies scales with fs. The reference frequency of these responses is 1kHz.

Note 15. The calculated delay time induced by digital filtering. This time is from the input of an analog signal to the setting of 32bit data both of channels to the ADC output register for ADC.

■ Digital Filter Plot

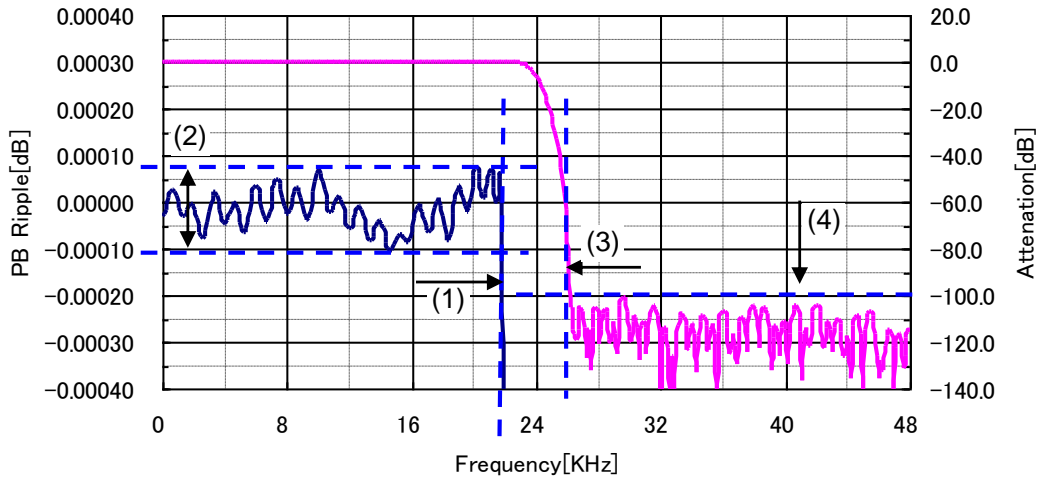

Figure 3. Sharp Roll Off Filter Normal Mode

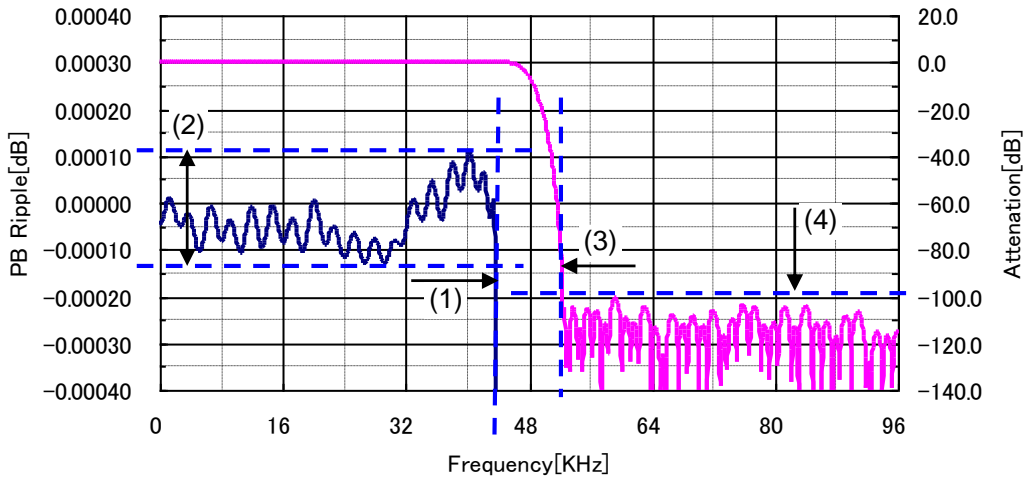

Figure 4. Sharp Roll Off Filter Double Mode

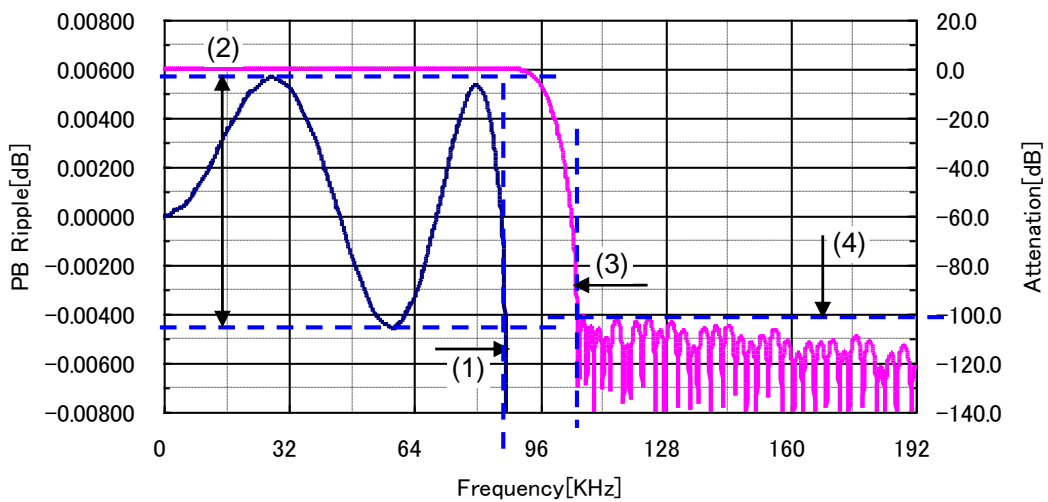

Figure 5. Sharp Roll Off Filter Quad Mode

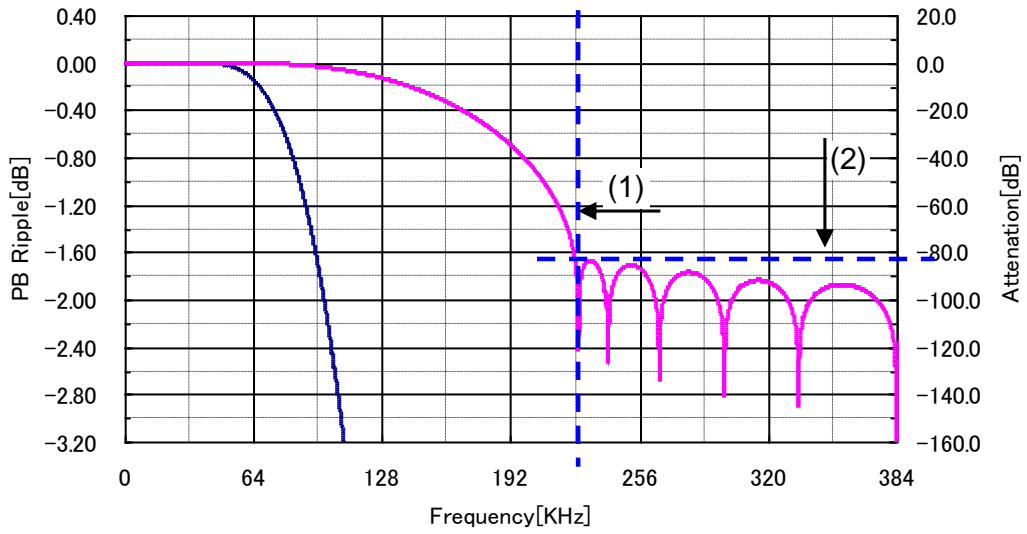

Figure 6. Sharp Roll Off Filter Octal Mode

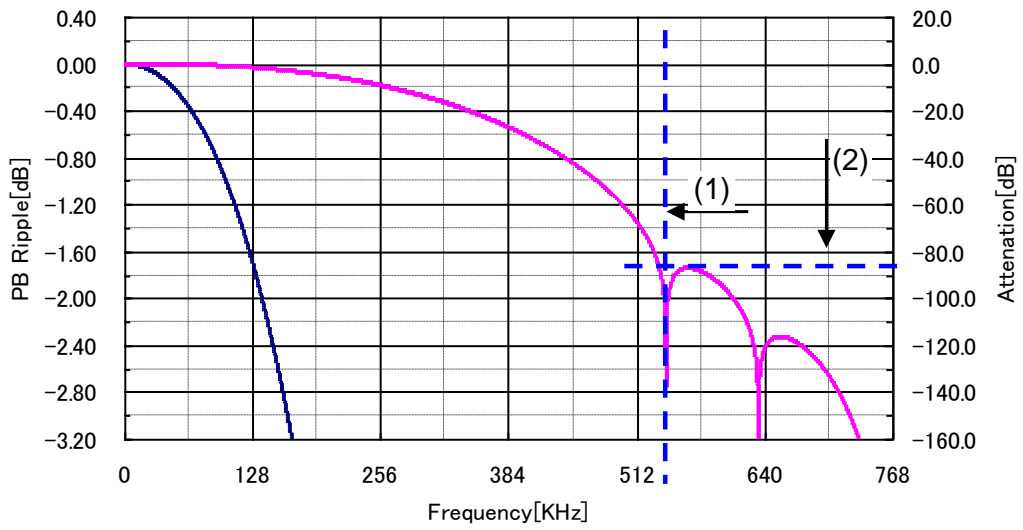

Figure 7. Sharp Roll Off Filter Hex Mode

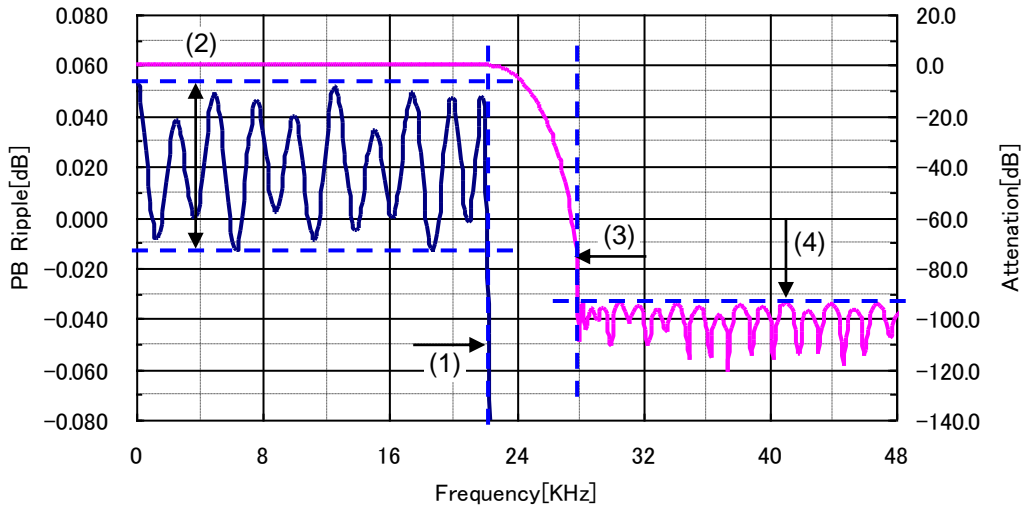

Figure 8 Short Delay Filter Normal Mode

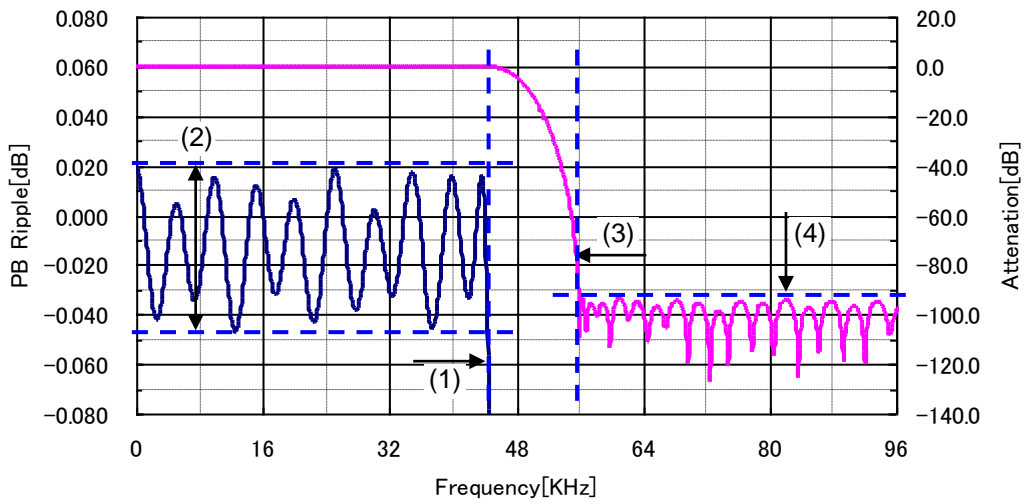

Figure 9. Short Delay Filter Double Mode

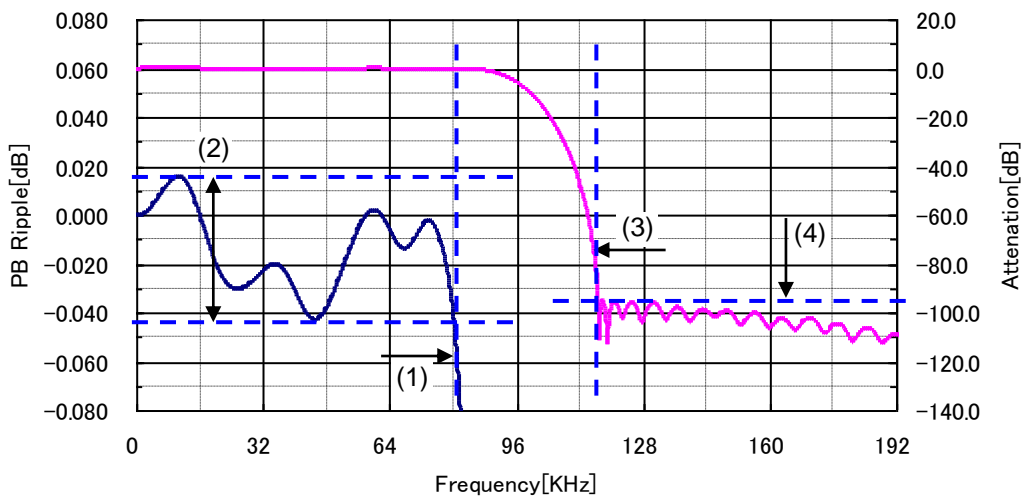

Figure 10. Short Delay Filter Quad Mode

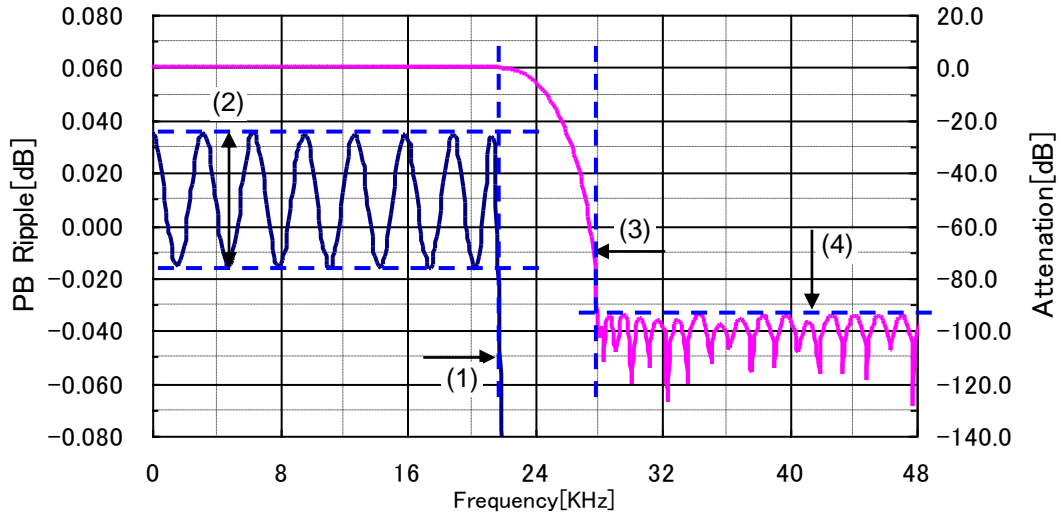

Figure 11. Minimum Phase Filter Normal Mode

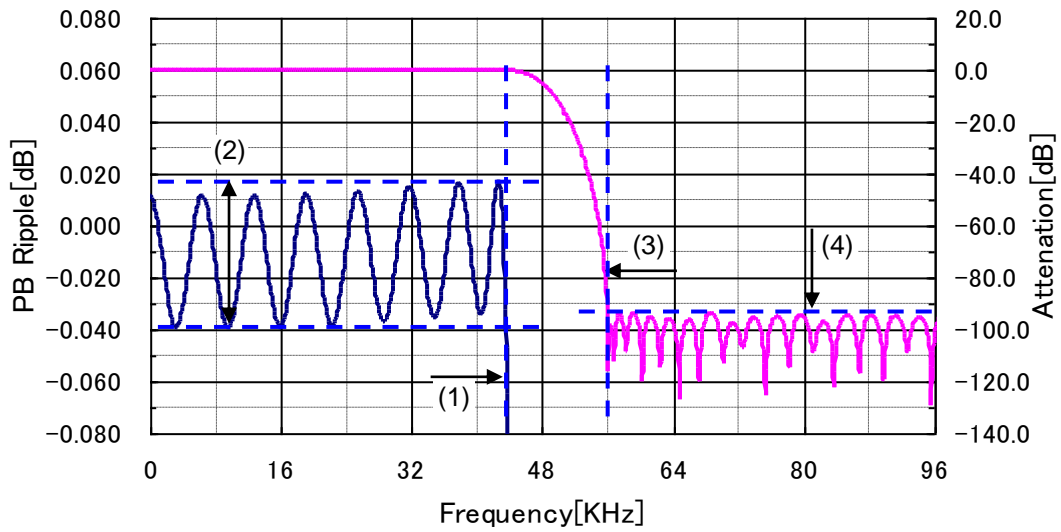

Figure 12. Minimum Phase Filter Double Mode

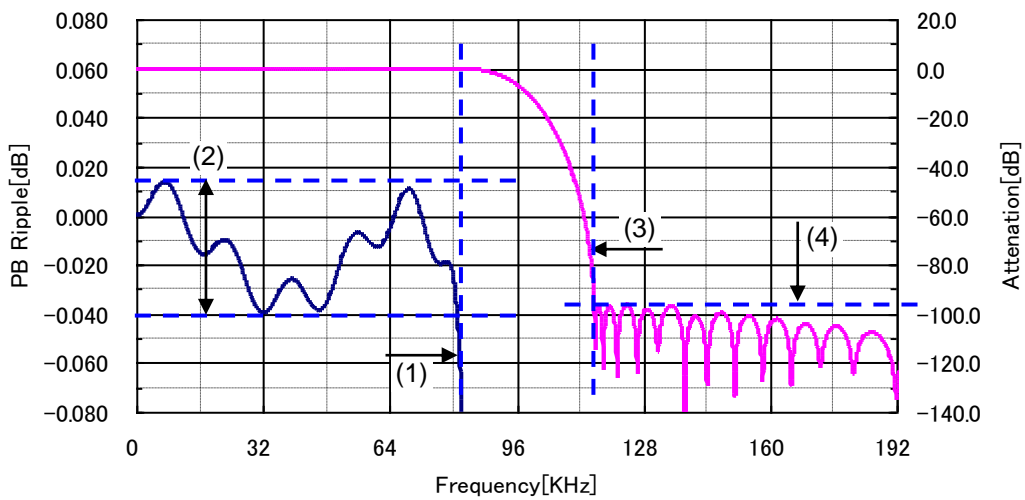

Figure 13. Minimum Phase Filter Quad Mode

■ DC Characteristics

(Ta= -10~70°C; AVDD=4.75~5.25V; DVDD=3.0~3.6V)

Parameter	Symbol	Min.	Typ.	Max.	Unit
High-Level Input Voltage (Note 5)	VIH	70%DVDD	-	-	V
Low-Level Input Voltage (Note 5)	VIL	-	-	30%DVDD	V
High-Level Output Voltage (Iout=-100μA)	VOH	DVDD-0.5	-	-	V
Low-Level Output Voltage (Iout= 100μA)	VOL	-	-	0.5	V
Input Leakage Current	Iin	-	-	±10	μA

Note 5. CKS0, CKS1, CKS2, PDN, SDM1, SDM2, SDFIL, TDMIN1, TDMIN2, MCLK, BICK, LRCK, DIF, MSN, HPFE, MONO, TDM0, TDM1pin

■ Switching Characteristics

(Ta= -10~70°C; AVDD=4.75~5.25V; DVDD=3.0~3.6V; CL=20pF)

Parameter	Symbol	Min.	Typ.	Max.	Unit
Master Clock Timing					
Frequency	fCLK	2.048	12.288	24.576	MHz
Pulse Width Low	tCLKL	0.4/fCLK			ns
Pulse Width High	tCLKH	0.4/fCLK			ns
LRCK Timing (Slave Mode)					
Normal mode (TDM1="L", TDM0="L")					
LRCK Frequency	fs	8		768	kHz
Duty Cycle	Duty	45		55	%
TDM256 MODE (TDM1="L", TDM0="H")					
LRCK Frequency	fs	8		48	kHz
"H" time	tLRH	1/256fs			ns
"L" time	tLRL	1/256fs			ns
TDM128 MODE (TDM1="H", TDM0="H")					
LRCK Frequency	fs	8		192	kHz
"H" time	tLRH	1/128fs			ns
"L" time	tLRL	1/128fs			ns
LRCK Timing (Master Mode)					
Normal mode (TDM1="L", TDM0="L")					
LRCK Frequency	fs	8		768	kHz
Duty Cycle	Duty		50		%
TDM256 MODE (TDM1="L", TDM0="H")					
LRCK Frequency	fs	8		48	kHz
"H" time (Note 16)	tLRH		1/8fs		ns
TDM128 MODE (TDM1="H", TDM0="H")					
LRCK Frequency	fs	8		192	kHz
"H" time (Note 16)	tLRH		1/4fs		ns

Note 16. "L" time at I²S format.

Parameter	Symbol	Min.	Typ.	Max.	Unit
Audio Interface Timing (Slave mode)					
Normal mode (TDM1="L", TDM0="L") (8kHz ≤ fs ≤ 192kHz)					
BICK Period (8kHz ≤ fs ≤ 48kHz)	tBCK	1/128fs			ns
(48kHz < fs ≤ 192kHz)	tBCK	1/64fs			ns
BICK Pulse Width Low	tBCKL	32			ns
Pulse Width High	tBCKH	32			ns
LRCK Edge to BICK "↑" (Note 17)	tLRB	20			ns
BICK "↑" to LRCK Edge (Note 17)	tBLR	20			ns
LRCK to SDTO1/2 (MSB) (Except I ² S mode)	tLRS			20	ns
BICK "↓" to SDTO1/2	tBSD			20	ns
Normal mode (TDM1="L", TDM0="L") (192kHz ≤ fs ≤ 768kHz)					
BICK Period (192kHz ≤ fs ≤ 384kHz)	tBCK	1/64fs			ns
(384kHz < fs ≤ 768kHz)	tBCK	1/32fs			ns
BICK Pulse Width Low	tBCKL	16			ns
Pulse Width High	tBCKH	16			ns
LRCK Edge to BICK "↑" (Note 17)	tLRB	10			ns
BICK "↑" to LRCK Edge (Note 17)	tBLR	10			ns
BICK "↓" to SDTO1/2	tBSD			10	ns
TDM256 mode (TDM1="L", TDM0="H")					
BICK Period	tBCK	1/256fs			ns
BICK Pulse Width Low	tBCKL	32			ns
Pulse Width High	tBCKH	32			ns
LRCK Edge to BICK "↑" (Note 17)	tLRB	20			ns
BICK "↑" to LRCK Edge (Note 17)	tBLR	20			ns
BICK "↓" to SDTO1/2	tBSD			20	ns
TDMIN1/2 Setup Time	tTDS	10			ns
TDMIN1/2 Hold Time	tTDH	10			ns
TDM128 mode (TDM1="H", TDM0="H") (8kHz ≤ fs ≤ 96kHz)					
BICK Period	tBCK	1/128fs			ns
BICK Pulse Width Low	tBCKL	32			ns
Pulse Width High	tBCKH	32			ns
LRCK Edge to BICK "↑" (Note 17)	tLRB	20			ns
BICK "↑" to LRCK Edge (Note 17)	tBLR	20			ns
BICK "↓" to SDTO1/2	tBSD			20	ns
TDMIN1/2 Setup Time	tTDS	10			ns
TDMIN1/2 Hold Time	tTDH	10			ns
TDM128 mode (TDM1="H", TDM0="H") (96kHz < fs ≤ 192kHz)					
BICK Period	tBCK	1/128fs			ns
BICK Pulse Width Low	tBCKL	16			ns
Pulse Width High	tBCKH	16			ns
LRCK Edge to BICK "↑" (Note 17)	tLRB	10			ns
BICK "↑" to LRCK Edge (Note 17)	tBLR	10			ns
BICK "↓" to SDTO1/2	tBSD			10	ns
TDMIN1/2 Setup Time	tTDS	10			ns
TDMIN1/2 Hold Time	tTDH	10			ns

Parameter	Symbol	Min.	Typ.	Max.	Unit
Audio Interface Timing (Master mode)					
Normal mode (TDM1="L", TDM0="L") BICK Frequency (8kHz ≤ fs ≤ 192kHz) (192kHz < fs ≤ 384kHz)	fBCK fBCK		64fs 32fs		Hz Hz
BICK Duty	dBCK		50		%
BICK "↓" to LRCK	tMBLR	-12		12	ns
BICK "↓" to SDTO1/2	tBSD	-20		20	ns
Normal mode (TDM1="L", TDM0="L") (384kHz < fs ≤ 768kHz)	fBCK dBCK		32fs 50		Hz %
BICK Duty	dBCK		50		%
BICK "↓" to LRCK	tMBLR	-6		6	ns
BICK "↓" to SDTO1/2	tBSD	-10		10	ns
TDM256 mode (TDM1="L", TDM0="H") BICK Frequency BICK Duty (Note 18)	fBCK dBCK		256fs 50		Hz %
BICK "↓" to LRCK	tMBLR	-12		12	ns
BICK "↓" to SDTO1/2	tBSD	-20		20	ns
TDMIN1/2 Setup Time	tTDS	10			ns
TDMIN1/2 Hold Time	tTDH	10			ns
TDM128 mode (TDM1="H", TDM0="H") (8kHz ≤ fs ≤ 96kHz)	fBCK dBCK		128fs 50		Hz %
BICK Duty	dBCK		50		%
BICK "↓" to LRCK	tMBLR	-12		12	ns
BICK "↓" to SDTO1/2	tBSD	-20		20	ns
TDMIN1/2 Setup Time	tTDS	10			ns
TDMIN1/2 Hold Time	tTDH	10			ns
TDM128 mode (TDM1="H", TDM0="H") (96kHz < fs ≤ 192kHz)	fBCK dBCK		128fs 50		Hz %
BICK Duty	dBCK		50		%
BICK "↓" to LRCK	tMBLR	-6		6	ns
BICK "↓" to SDTO1/2	tBSD	-10		10	ns
TDMIN1/2 Setup Time	tTDS	10			ns
TDMIN1/2 Hold Time	tTDH	10			ns
Reset timing RSTN Pulse width	tRTW	150			ns

Note 17. BICK rising edge must not occur at the same time as LRCK edge.

Note 18. This value is MCLK=512fs. Duty cycle is not guaranteed when MCLK=256fs.

■ Timing Diagrams

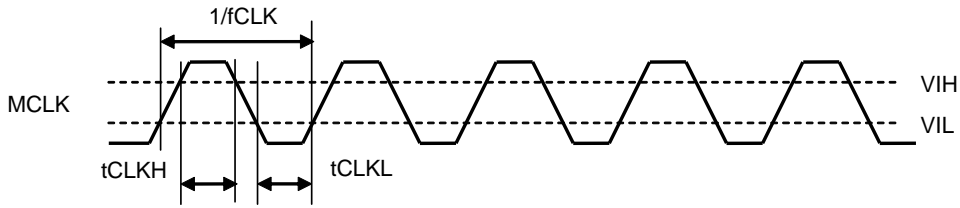

Figure 14. MCLK Timing (TDM0 pin = "L" or "H")

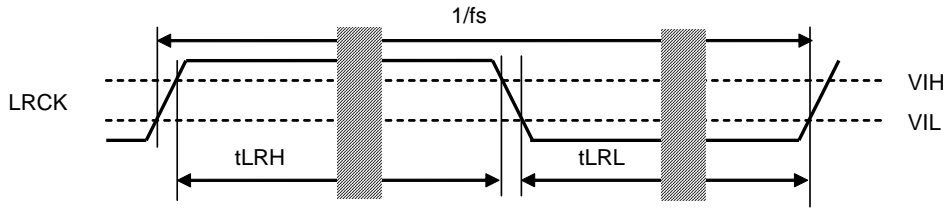

Figure 15. LRCK Timing (TDM0 pin = "L" or "H")

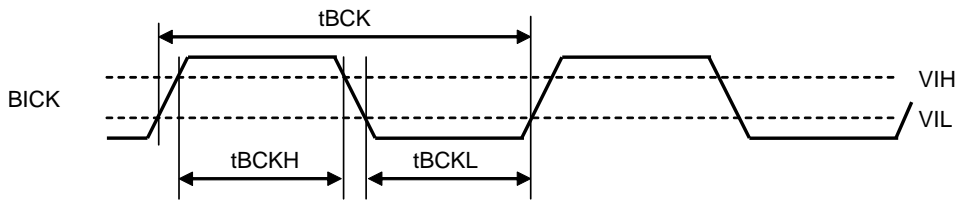

Figure 16. BICK Timing (TDM0 pin = "L" or "H")

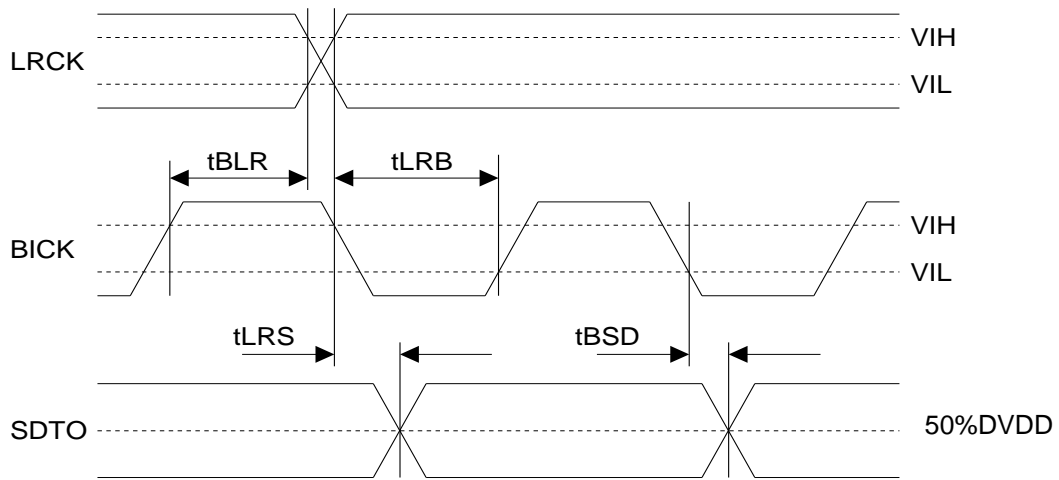

Figure 17. Audio Interface Timing (Slave mode, TDM0 pin = "L")

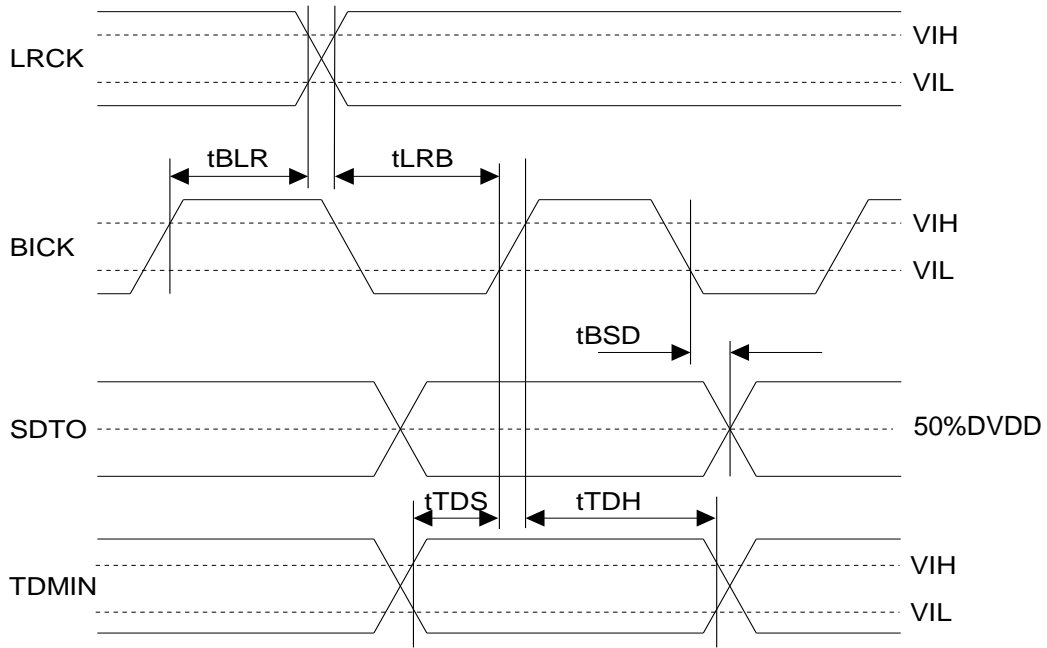

Figure 18. Audio Interface Timing (Slave mode, TDM0 pin = "H")

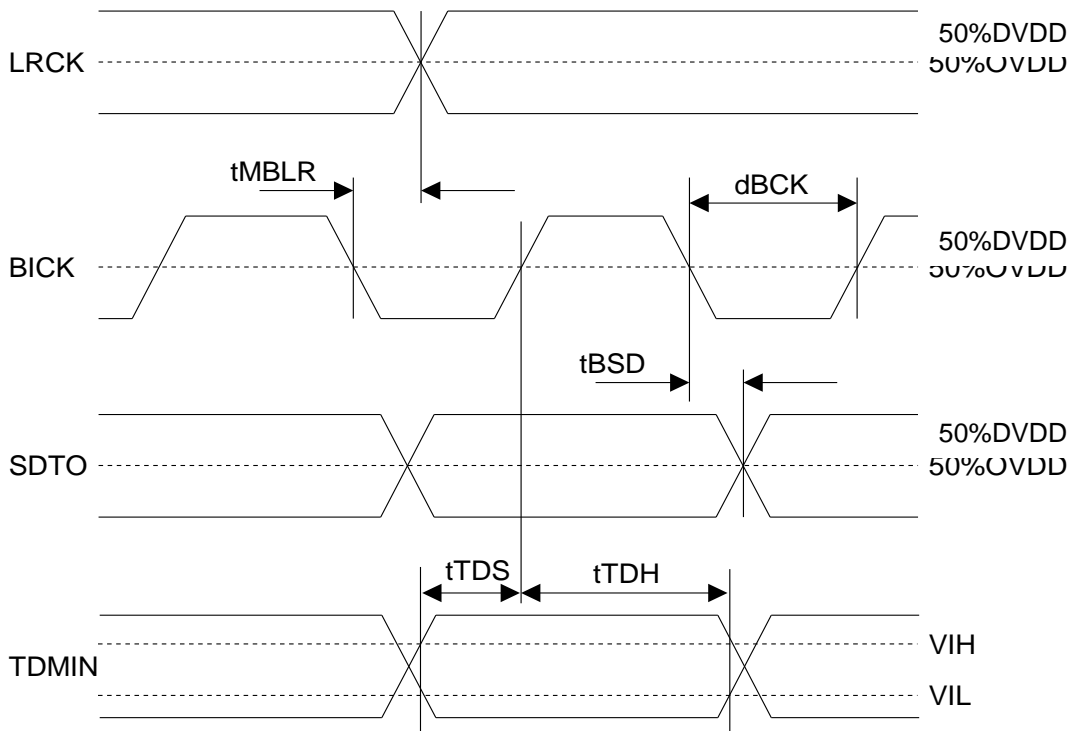

Figure 19. Audio Interface Timing (Master mode, TDM0 pin= "H" or "L")

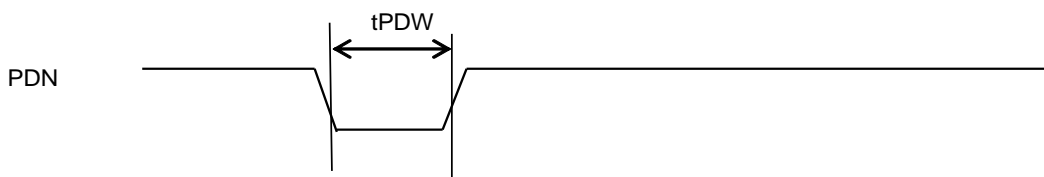

Figure 20. Reset & Calibration Timing

Note: SDTO shows SDTO1 and SDTO2. TDMIN shows TDMIN1 and TDMIN2.

9. Functional Descriptions

■ System Clock

MCLK, BICK and LRCK (fs) clocks are required in slave mode. A stable clock must be supplied when the AK5397 is in operation (PDN pin = "H"). The LRCK clock input must be synchronized with MCLK, however the phase is not critical. [Table 1](#) shows the relationship of typical sampling frequency and the system clock frequency. MCLK frequency, BICK frequency and master/slave mode are selected by CKS2-0 and MSN pins as shown in [Table 2](#).

The MSN pin controls Master/Slave mode switching. The AK5397 outputs BICK and LRCK in master mode when inputting MCLK. When the AK5397 is in slave mode, MCLK, BICK and LRCK should be input. ([Table 4](#))

For synchronization between multiple devices, the AK5397 should be reset by the PDN pin after an operation clock change, clock mode switching, digital I/F change and Master/Slave mode switching. Clock and Mode changes should only be made during the reset.

fs	MCLK				
	32fs	64fs	128fs	256fs	512fs
32kHz	N/A	N/A	N/A	8.192MHz	16.384MHz
44.1kHz	N/A	N/A	N/A	11.2896MHz	22.5792MHz
48kHz	N/A	N/A	N/A	12.288MHz	24.576MHz
96kHz	N/A	N/A	N/A	24.576MHz	N/A
192kHz	N/A	N/A	24.576MHz	N/A	N/A
384kHz	N/A	24.576MHz	N/A	N/A	N/A
768kHz	24.576MHz	N/A	N/A	N/A	N/A

Table 1. System Clock Example (N/A: Not Available)

MSN pin	CKS2 pin	CKS1 pin	CKS0 pin	MCLK	BICK	Sampling Speed
L (Slave)	0	0	0	256fs	$64fs \leq BICK \leq 128fs$	Normal Speed Mode ($8kHz \leq fs \leq 48kHz$)
	0	0	1	(Table 3)		Auto Setting Mode
	0	1	0	256fs	64fs	Double Speed Mode ($48kHz < fs \leq 96kHz$)
	0	1	1	128fs	64fs	Quad Speed Mode ($96kHz < fs \leq 192kHz$)
	1	0	0	64fs	64fs	Octal Speed Mode ($fs = 384kHz$)
	1	0	1	32fs	32fs	Hex Speed Mode ($fs = 768kHz$)
	1	1	0	N/A		
	1	1	1			
H (Master)	0	0	0	256fs	64fs	Normal Speed Mode ($8kHz \leq fs \leq 48kHz$)
	0	0	1	512fs	64fs	
	0	1	0	256fs	64fs	Double Speed Mode ($48kHz < fs \leq 96kHz$)
	0	1	1	128fs	64fs	Quad Speed Mode ($96kHz < fs \leq 192kHz$)
	1	0	0	64fs	64fs	Octal Speed Mode ($fs = 384kHz$)
	1	0	1	32fs	32fs	Hex Speed Mode ($fs = 768kHz$)
	1	1	0	N/A		
	1	1	1			

Table 2. Setting of MCLK /BICK/Sampling Speed

MCLK	BICK	Sampling Speed
512fs	$64fs \leq BICK \leq 128fs$	Normal Speed Mode ($8kHz \leq fs \leq 48kHz$)
256fs	64fs	Double Speed Mode ($48kHz < fs \leq 96kHz$)
128fs	64fs	Quad Speed Mode ($96kHz < fs \leq 192kHz$)
64fs	64fs	Octal Speed Mode ($fs = 384kHz$)
32fs	32fs	Hex Speed Mode ($fs = 768kHz$)

Table 3. Auto Setting Mode (Slave Mode)

■ Master Mode/Slave Mode

The MSN pin selects either master or slave modes as shown in Table 4. The AK5397 outputs BICK and LRCK in master mode. In slave mode, provide MCLK, BICK and LRCK.

MSN pin	Mode	BICK, LRCK
L	Slave Mode	BICK = Input LRCK = Input
H	Master Mode	BICK = Output LRCK = Output

Table 4. Master mode/Slave mode

■ Audio Interface Format

12 types of audio data interface can be selected by the TDM1-0, MSN and DIF pins as shown in [Table 5](#). The audio data format can be selected by the DIF pin. In all formats the serial data is MSB-first, 2's complement format. The SDTO1/2 is clocked out on the falling edge of BICK.

In normal mode, Mode 0-1 are the slave mode, and Mode 2-3 are the master mode. BICK frequency is shown in [Table 2](#).

In TDM256 mode, BICK must be fixed to 256fs. In the slave mode, "H" time and "L" time of LRCK must be 1/256fs at least. In the master mode, "H" time ("L" time at I²S mode) of LRCK is 1/8fs typically. TDM256 mode supports only Normal Speed.

In TDM128 mode, BICK must be fixed to 128fs. In the slave mode, "H" time and "L" time of LRCK must be 1/128fs at least. In the master mode, "H" time ("L" time at I²S mode) of LRCK is 1/4fs typically. TDM128 mode supports Normal/Double/Quad Speed.

TDM1 pin	TDM0 pin	MSN pin	DIF pin	Mode	SDTO	LRCK		BICK		
							I/O		I/O	
L	L	L (Slave)	L	0	Normal	32bit, MSB justified	H/L	I	(Table 2)	I
			H	1		32bit, I ² S Compatible	L/H	I		I
		H (Master)	L	2		32bit, MSB justified	H/L	O		O
			H	3		32bit, I ² S Compatible	L/H	O		O
L	H	L (Slave)	L	4	TDM256	32bit, MSB justified	↑	I	256fs	I
			H	5		32bit, I ² S Compatible	↓	I	256fs	I
		H (Master)	L	6		32bit, MSB justified	↑	O	256fs	O
			H	7		32bit, I ² S Compatible	↓	O	256fs	O
H	H	L (Slave)	L	8	TDM128	32bit, MSB justified	↑	I	128fs	I
			H	9		32bit, I ² S Compatible	↓	I	128fs	I
		H (Master)	L	10		32bit, MSB justified	↑	O	128fs	O
			H	11		32bit, I ² S Compatible	↓	O	128fs	O
H	L	N/A	N/A	12	N/A	N/A	N/A	N/A	N/A	

Table 5. Audio Interface Format (N/A: Not available)

Sampling Speed	Audio Interface Format	The maximum number of channels
Normal Speed	Normal	2ch
	TDM256	8ch
	TDM128	4ch
Double Speed	Normal	2ch
	TDM256	N/A
	TDM128	4ch
Quad Speed	Normal	2ch
	TDM256	N/A
	TDM128	4ch
Octal Speed	Normal	2ch
	TDM256	N/A
	TDM128	N/A
Hex Speed	Normal	2ch (SDTO1: Lch, SDTO2: Rch)
	TDM256	N/A
	TDM128	N/A

Table 6. Relationship between Sampling Speed and Audio Interface Format (N/A: Not available)

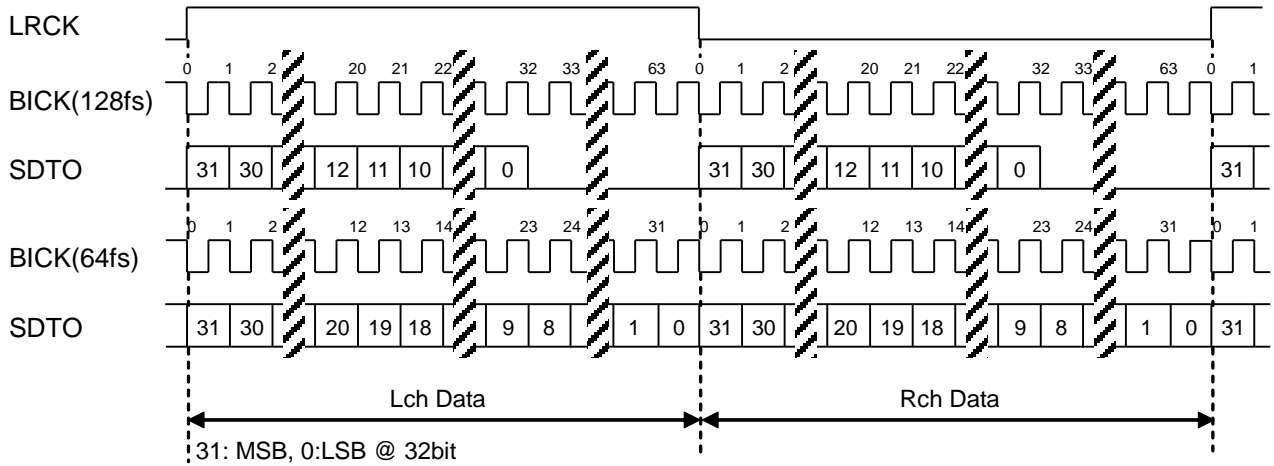

Figure 21. Mode 0/2 Timing (Normal mode, MSB justified, Normal/Double/Quad/Octal speed mode)

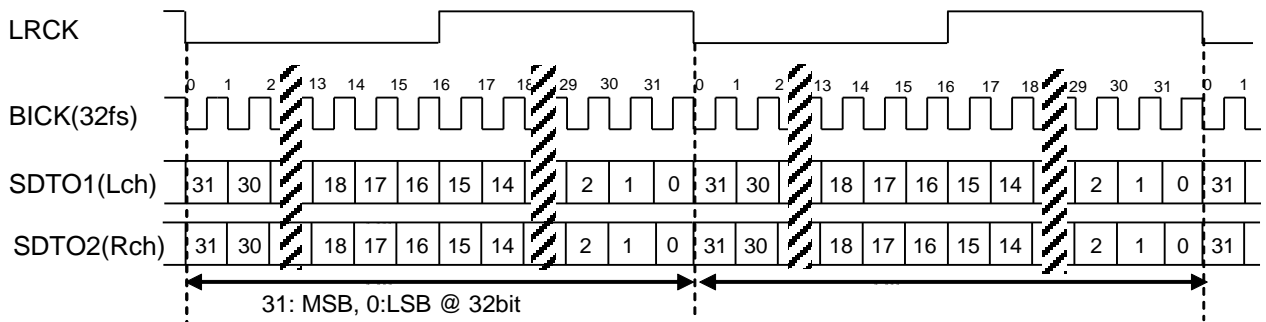

Figure 22. Mode 0/2 Timing (Normal mode, MSB justified, Hex speed mode)

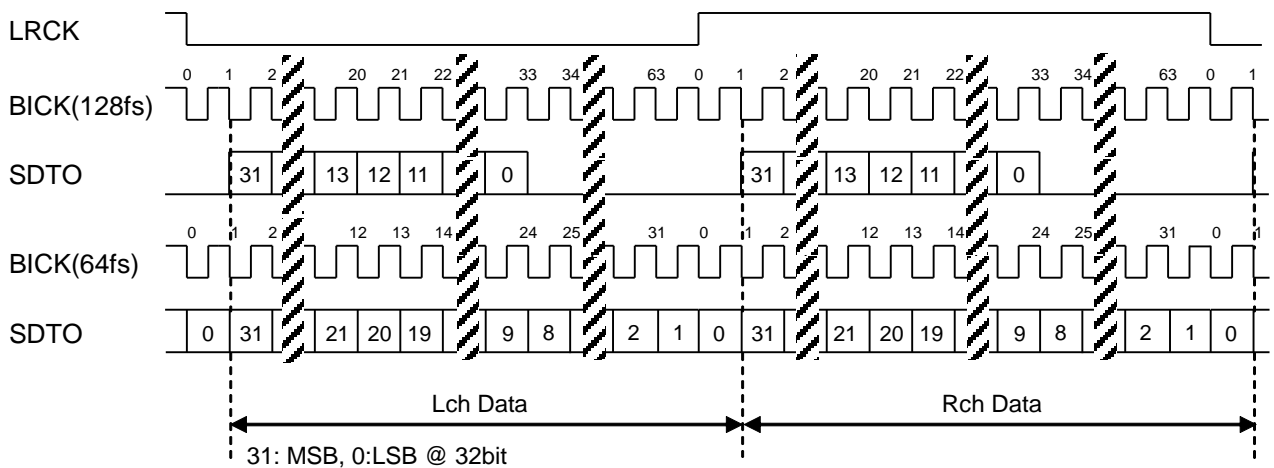

Figure 23. Mode 1/3 Timing (Normal mode, I²S Compatible, Normal/Double/Quad/Octal Speed)

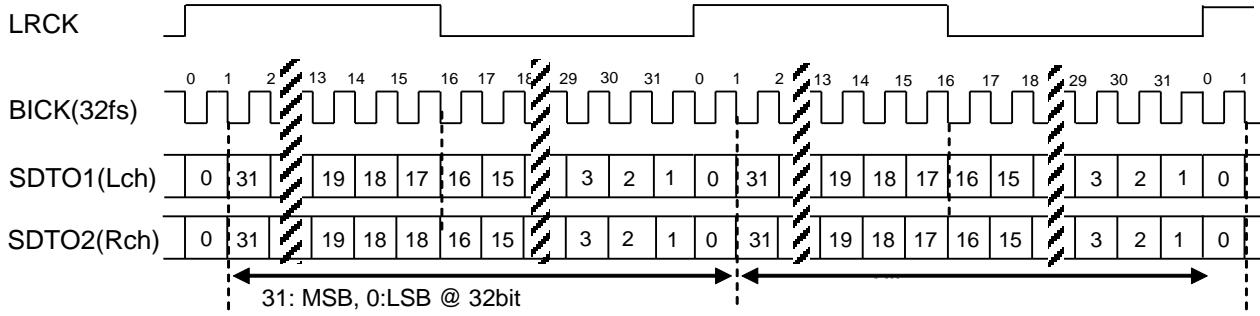

Figure 24. Mode 1/3 Timing (Normal mode, I²S Compatible, Hex Speed)

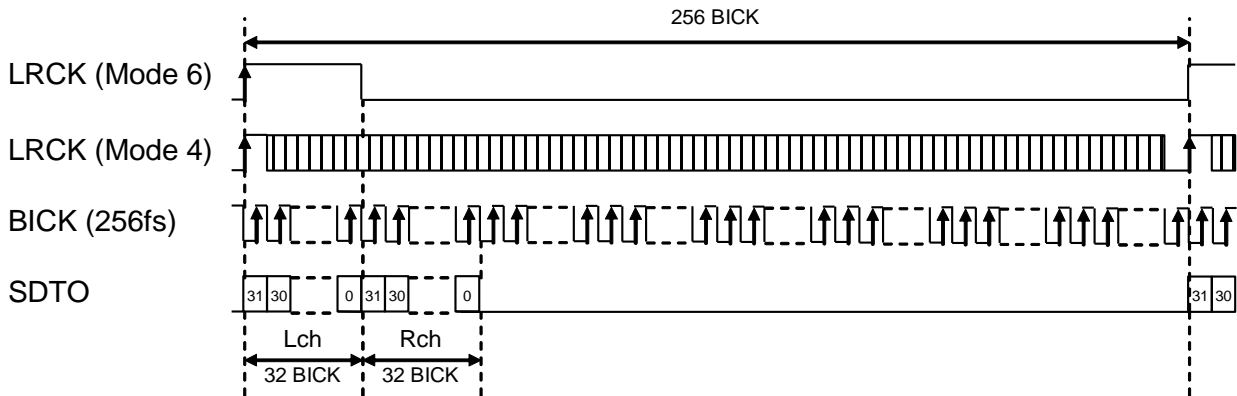

Figure 25. Mode 4/6 Timing (TDM256 mode, MSB justified)

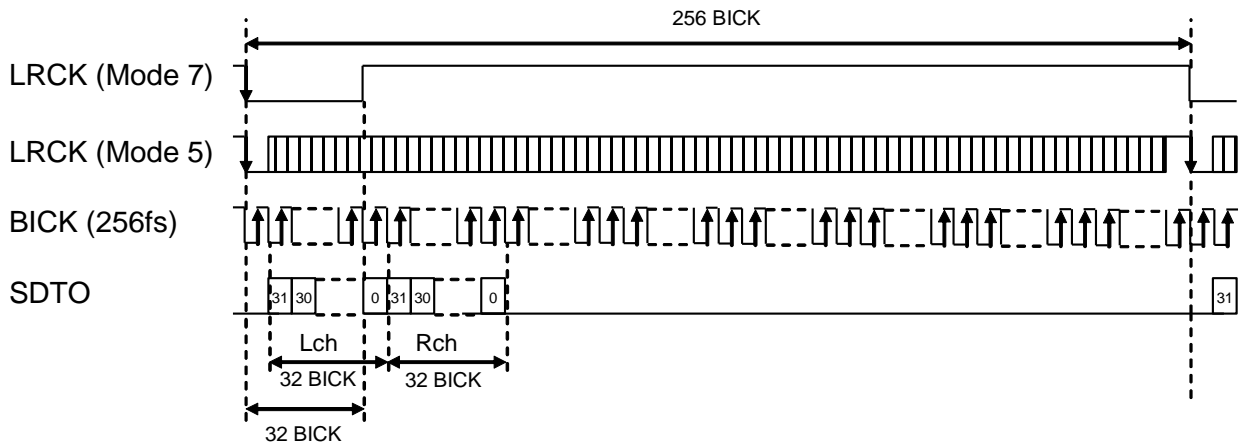

Figure 26. Mode 5/7 Timing (TDM256 mode, I²S Compatible)

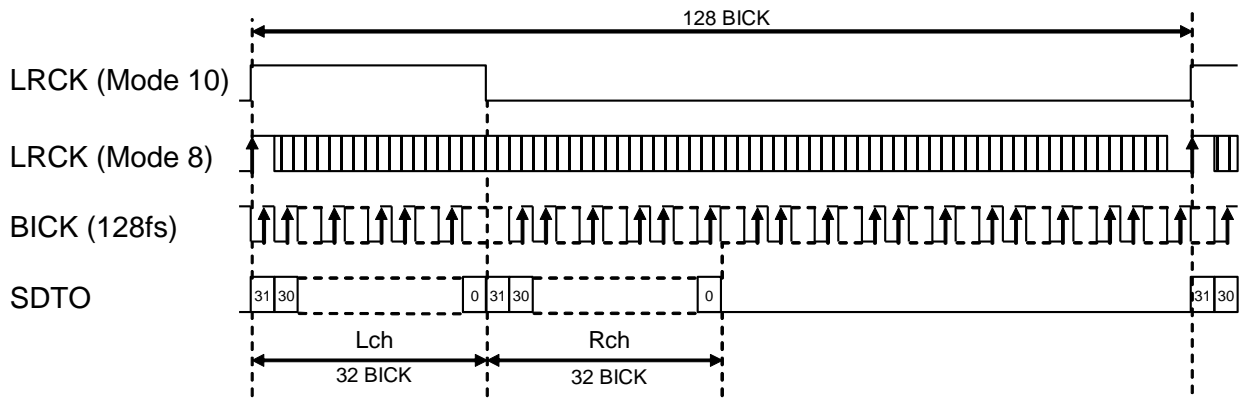

Figure 27. Mode 8/10 Timing (TDM128 mode, MSB justified)

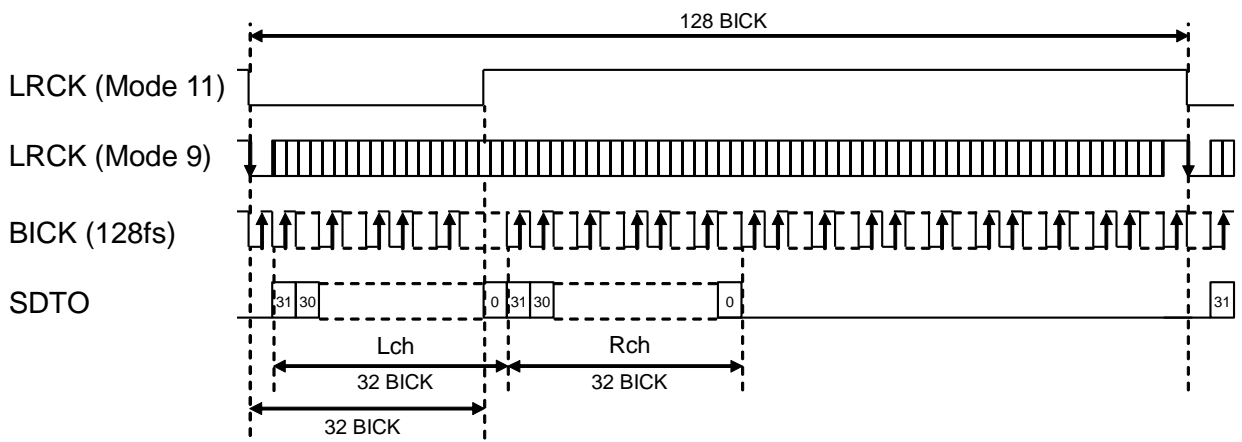

Figure 28. Mode 9/11 Timing (TDM128 mode, I²S Compatible)

■ Cascade TDM Mode

(1) TDM256 mode

The AK5397 supports cascading of up to four devices in a daisy chain configuration at TDM256 mode. In this mode, the SDTO1 pin (SDTO2 pin) is connected to the TDMIN1 pin (TDMIN2 pin) of next device. When four devices are connected by daisy-chaining as Figure 29, the SDTO1 pin (SDTO2 pin) of device #4 can send 8ch TDM data.

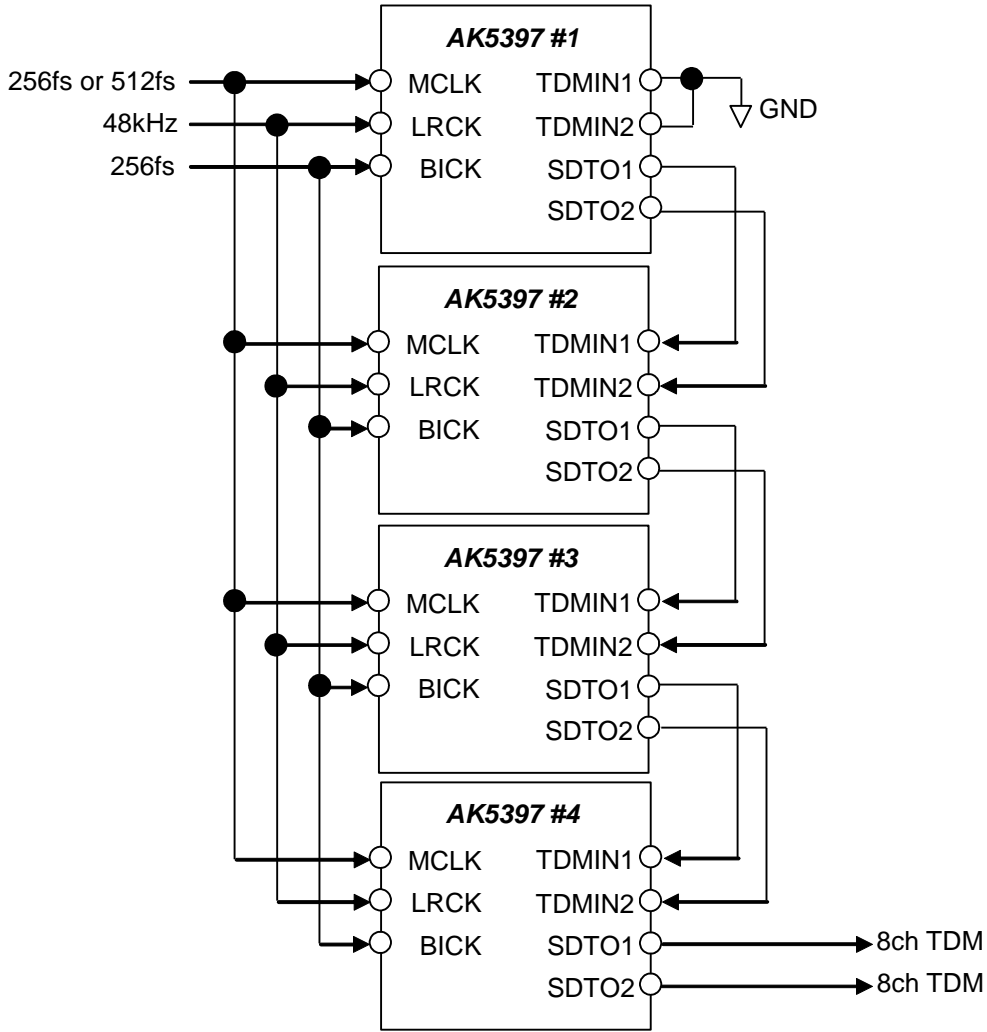

Figure 29. Cascade TDM Connection Diagram

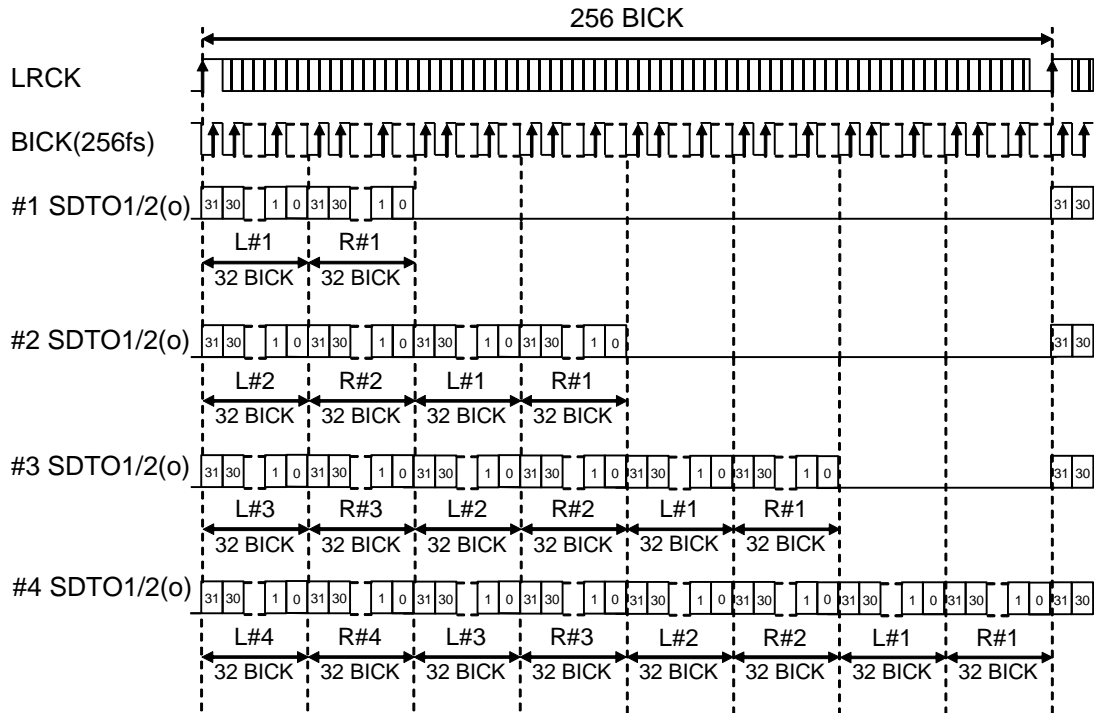

Figure 30. Cascade TDM Timing (Mode 4; TDM256 mode, MSB justified, Slave mode)

(2) TDM128 mode

The AK5397 supports cascading of two devices in a daisy chain configuration at TDM128 mode. In this mode, the SDTO1 pin (SDTO2 pin) is connected to the TDMIN1 pin (TDMIN2 pin) of next device. When two devices are connected by daisy-chaining as Figure 31, the SDTO1 pin (SDTO2 pin) of device #2 can send 4ch TDM data.

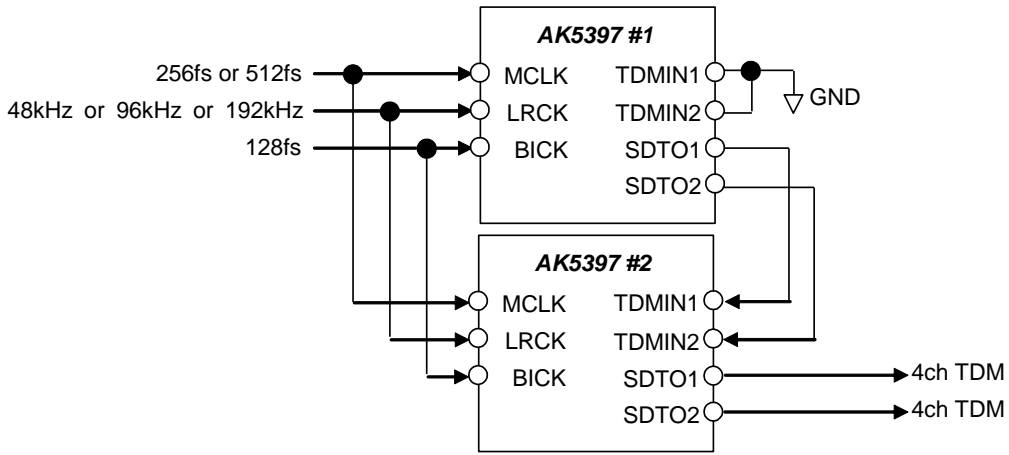

Figure 31. Cascade TDM Connection Diagram

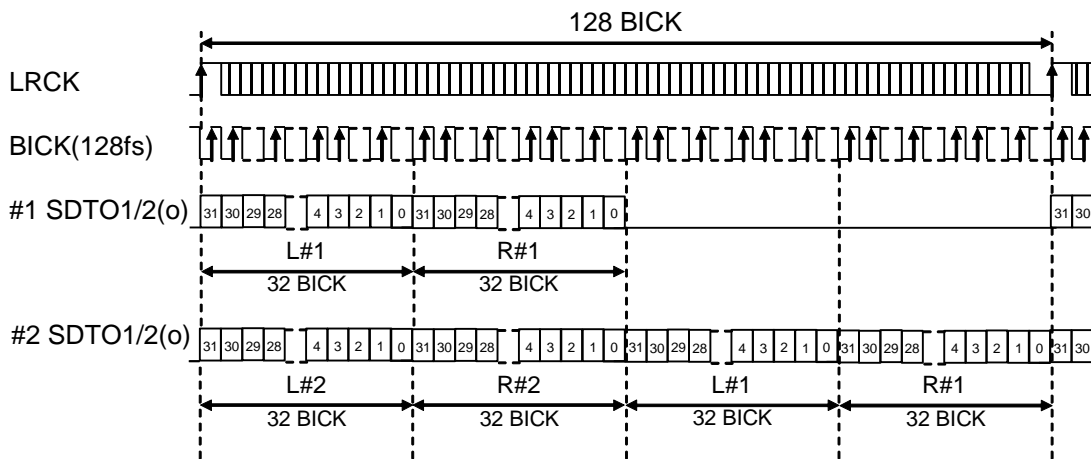

Figure 32. Cascade TDM Timing (Mode 8; TDM128 mode, MSB justified, Slave mode)

When using multiple devices in slave mode on cascade connection, internal operation timing of each device may differ for one MCLK cycle depending on PDN, MCLK and BICK input timings. To prevent this timing difference, BICK “↓” should be more than ± 10ns from MCLK “↑” and PDN “↑” should be more than ± 15ns from MCLK “↑” as shown in Table 7.

This timing can be achieved by inputting BICK divided half on MCLK “↓” when MCLK=2 x BICK (Normal 512fs, Double Speed) (Figure 33), and can be achieved by inputting BICK synchronized to MCLK when MCLK=BICK (Normal 256fs mode, Quad speed) (Figure 34).

Parameter	Symbol	min	typ	max	Unit
MCLK “↑” to BICK “↓”	tMCB	10			ns
BICK “↓” to MCLK “↑”	tBIM	10			ns
MCLK “↑” to PDN “↑”	tMPD	15			ns
PDN “↑” to MCLK “↑”	tPDM	15			ns

Table 7. TDM Mode Clock Timing

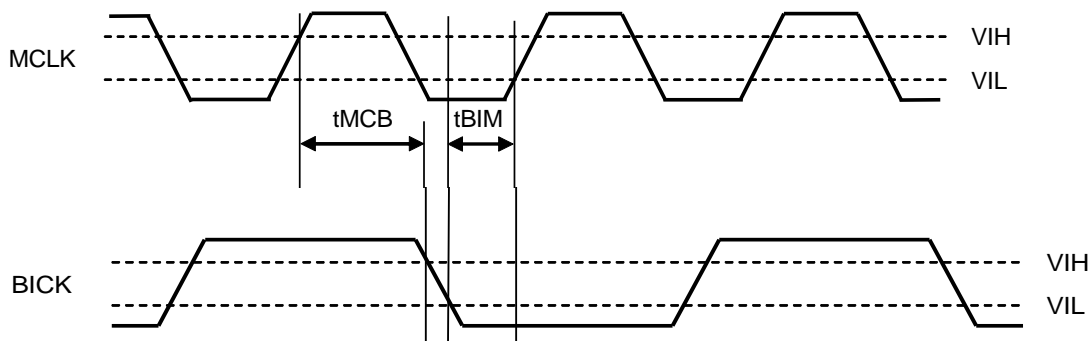

Figure 33. Audio Interface Timing (Slave mode, TDM Mode MCLK=2 x BICK)

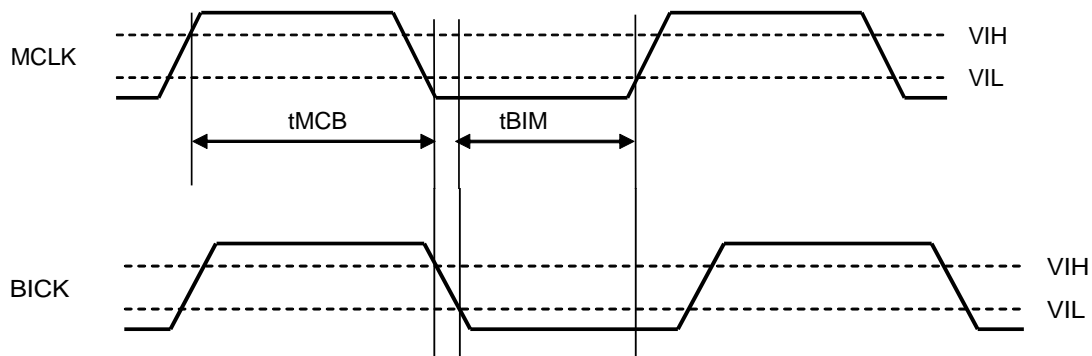

Figure 34. Audio Interface Timing (Slave mode, TDM Mode MCLK=BICK)

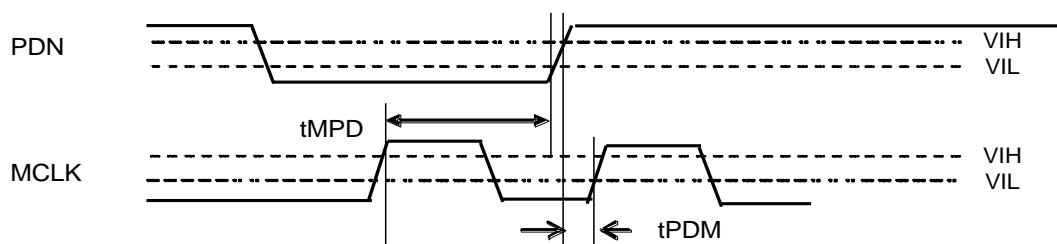

Figure 35. Reset Timing (Slave mode, TDM Mode)

■ Digital High Pass Filter

The AK5397 has a digital high pass filter for DC offset cancellation. The high pass filter is controlled by the HPFE pin as shown by Table 8 and is reflected in both SDTO1 and SDTO2. The cut-off frequency of the high pass filter is fixed 1.0Hz. The high pass filter is disabled in fs=384KHz mode or fs=768KHz mode, and the setting of HPFE pin is ignored. The high pass filter setting should only be changed when the PDN pin = "L".

HPFE pin	HPF
L	OFF
H	ON

Table 8. Setting of HPF

■ Overflow Detection

The AK5397 has an overflow detect function for the analog input. The OVF pin becomes "H" for one cycle after LRCK "↑" if either channel overflows (more than -0.276dBFS). The OVF output for overflowed analog input has the same group delay as the ADC. The OVF pin is "L" for 1028/fs (=21.41ms@fs=48kHz) after the PDN pin="↑", and then overflow detection is enabled.

■ Mono Mode

When the MONO pin is set to "H", the AK5397 becomes MONO mode. In the Mono mode, L channel and R channel data are summed digitally and divided into half. The dynamic range and S/N can be improved about 3dB when the same analog signal is input to left and right channels. In this mode, the left and right channel data on SDTO1 and SDTO2 are the same data.

MONO pin	SDTO1/2 Output Data
L	Stereo Mode
H	Mono Mode

Table 9. The setting of MONO mode.

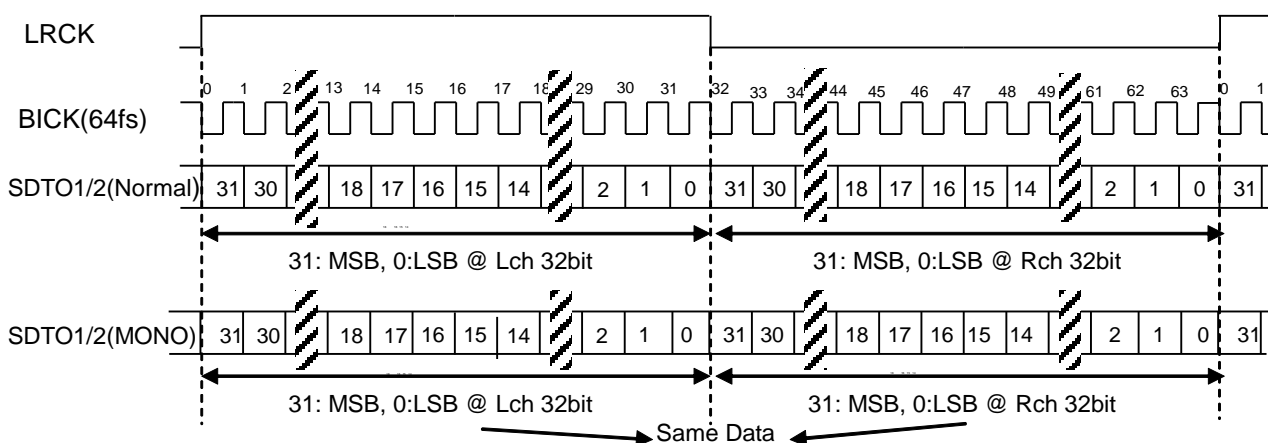

Figure 36. Audio Interface Timing (Normal mode or MONO mode, MSB justified)

■ Digital Output Data

The AK5397 has two kinds of output data. These data are sent from SDTO1 and SDTO2 pins at the same time. The SDTO1 pin is passed through “Sharp Roll-off” and the SDTO2 pin is passed through “Short Delay Filter” or “Minimum Phase Filter” selected by the SDFIL pin as shown by Table 12.

When $f_s=384\text{kHz}$, 768kHz , the AK5397 does not support “Short Delay Filter” and “Minimum Phase Filter”. When $f_s=384\text{kHz}$, the SDTO1 pin is passed through “Sharp Roll-off Filter”, and the SDTO2 pin is “L”. When $f_s=768\text{kHz}$, the SDTO1 and SDTO2 pins are passed through “Sharp Roll-off Filter” as shown in Table 10. However, in MONO mode, the SDTO1 pin outputs the data of $(Lch+Rch)/2$, and the SDTO2 pin is “L” as shown in Table 11.

The output data of SDTO1 and SDTO2 pins can be disabled by using SDM1 and SDM2 pins respectively as shown in Figure 37, Table 13 and Table 14. However, the SDM2 pin can output data if $f_s=768\text{kHz}$ even when the SDM2 pin = “H”.

Sampling Speed	SDTO1 Output Data	SDTO2 Output Data
48kHz	Sharp Roll-off Filter	Short Delay Filter
96kHz	Sharp Roll-off Filter	Short Delay Filter
192kHz	Sharp Roll-off Filter	Short Delay Filter
384kHz	Sharp Roll-off Filter	“L” Output
768kHz	Sharp Roll-off Filter (Lch)	Sharp Roll-off Filter (Rch)

Table 10. SDTO1 / SDTO2 Output Data (MONO = “L”)

Sampling Speed	SDTO1 Output Data	SDTO2 Output Data
48kHz	Sharp Roll Off Filter	Short Delay Filter
96kHz	Sharp Roll Off Filter	Short Delay Filter
192kHz	Sharp Roll Off Filter	Short Delay Filter
384kHz, 768kHz	Sharp Roll Off filter (Lch+Rch)/2	“L” Output

Table 11. SDTO1 / SDTO2 Output Data (MONO = “H”)

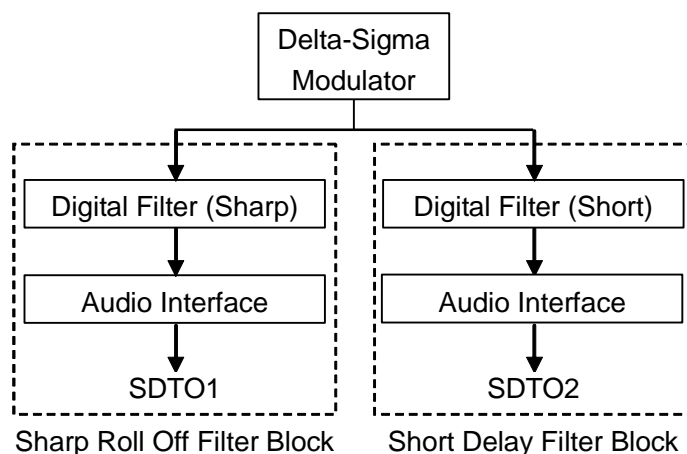

Figure 37. Digital Filter Block

SDFIL pin	SDTO2 Output Data
L	Short Delay Filter
H	Minimum Phase Filter

Table 12. The setting of SDFIL pin

SDM1 pin	SDTO1 Output Data
L	Normal output
H	"L" output

Table 13. The setting of SD1M pin

SDM2 pin	SDTO2 Output Data
L	Normal output
H	"L" output

Table 14. The setting of SD2M pin

The SDTO1/2 outputs settle to data correspondent to the analog input signals after group delay time when SDM1/2 pins are changed "H" → "L" and SDTO1/2 pins are in Normal Output Mode.

■ Power Down & Reset

The AK5397 is placed in the power-down mode by bringing the PDN pin “L” and the digital filter is also reset at the same time. This reset should always be made after power-up. In the power-down mode, the VCOM is AVSS level. An analog initialization cycle starts after exiting the power-down mode. The output data SDTO1/2 are valid after 1028 cycles of LRCK clock in master mode (1029 cycles in slave mode). During initialization, the ADC digital data outputs of both channels are forced to “0”. The ADC outputs settle to data correspondent to the input signals after the end of initialization (This settling takes approximately the group delay time).

The AK5397 should be reset once by bringing the PDN pin “L” after power-up. The AK5397 exits reset and power down state by MCLK rising edge after setting the PDN pin to “H”. The internal timing starts clocking by the rising edge (falling edge in I2S mode) of LRCK after exiting reset and power down state by MCLK.

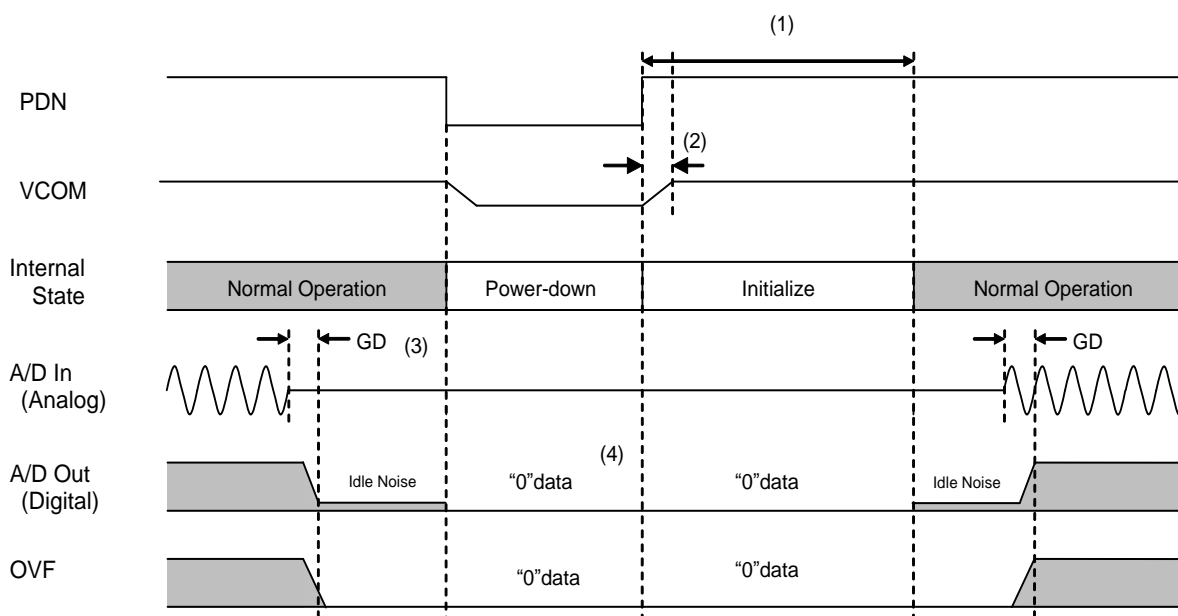

Notes:

- (1) 1030/fs in slave mode, 1031/fs in master mode.
- (2) The VCOM voltage reaches 2.5V in 1.53 ms (typ), 2.64ms (max) after the PDN pin = “H”.
- (3) Analog output corresponding to digital input has group delay (GD).
- (4) ADC and OVF outputs are “0” data in the power-down mode.

Figure 38. Power-down/up sequence example

10. SYSTEM DESIGN

Figure 39 shows the system connection diagram. An evaluation board (AKD5397) is available for fast evaluation as well as suggestions for peripheral circuitry.

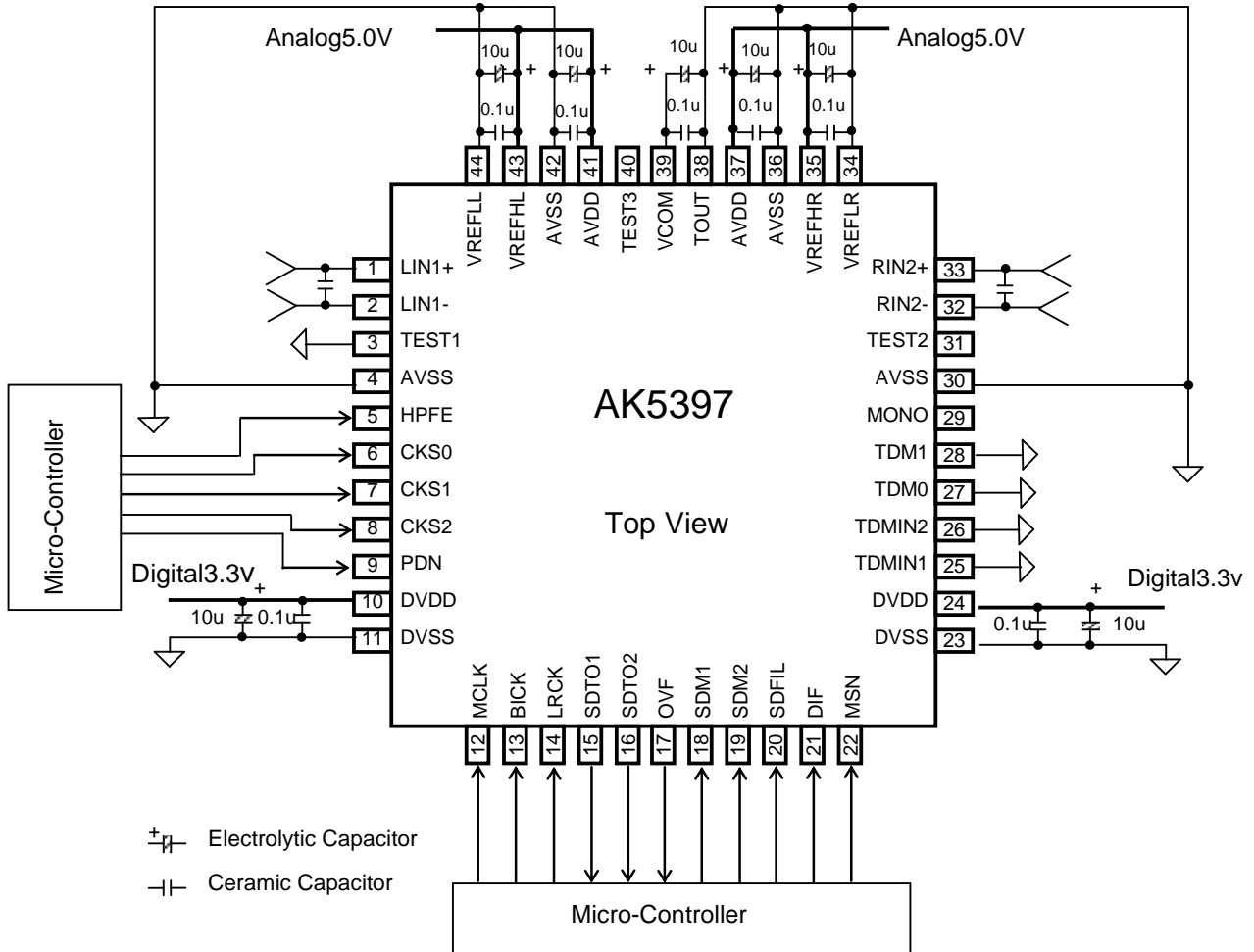

Note:

- AVSS and DVSS of the AK5397 must be distributed separately from the ground of external controllers.
- All digital input pins should not be left floating.

Figure 39. System Design

1. Grounding and Power Supply Decoupling

The AK5397 requires careful attention to power supply and grounding arrangements. To minimize digital noise coupling, AVDD and DVDD should be individually de-coupled at the AK5397. AVDD is usually supplied from analog supply in system and DVDD is supplied from digital supply in system. Power lines of AVDD and DVDD should be distributed separately from the point with low impedance of regulator etc. AVSS and DVSS must be connected to the same analog ground plane. Decoupling capacitors for high frequency should be placed as near as possible to the supply pin.

2. Voltage Reference Inputs

The reference voltage for A/D converter is the difference between VREFHL/R pin and VREFLL/R pin. VREFLL/R pins are connected to AVSS and an electrolytic capacitor over 10 μ F parallel with a 0.1 μ F ceramic capacitor between the VREFHL/R pin and the VREFLL/R pin eliminates the effects of high frequency noise. It is important that a ceramic capacitor should be as near to the pins as possible. All digital signals, especially clocks, should be kept away from the VREFHL/R and VREFLL/R pins in order to avoid unwanted coupling into the AK5397.

VCOM is a signal ground of this chip. A 10 μ F electrolytic capacitor in parallel with a 0.1 μ F ceramic capacitor attached to the VCOM pin eliminates the effects of high frequency noise. No load current may be drawn from the VCOM pin. All signals, especially clocks, should be kept away from the VCOM pin in order to avoid unwanted coupling into the AK5397.

3. Analog Inputs

The Analog input signal is differentially supplied into the modulator via the LIN+ (RIN+) and the LIN- (RIN-) pins. The input voltage is the difference between the LIN+ (RIN+) and LIN- (RIN-) pins. The full scale signal on each pin is nominally ± 2.80 V (typ). The output code format is two's complement. The output voltage (VAOUT) is positive full scale for 7FFFFFFFH (@32bit) and negative full scale for 80000000H (@32bit). The ideal VAOUT is 0V for 00000000H (@32bit). The internal HPF removes DC offset.

The AK5397 samples the analog inputs at 128fs (6.144MHz@fs=48kHz, Normal Speed Mode). The digital filter rejects noise above the stop band except for multiples of 128fs. The AK5397 includes an anti-aliasing filter (RC filter) to attenuate a noise around 128fs.

The AK5397 requires a +5V analog supply voltage. Any voltage which exceeds the upper limit of AVDD+0.3V and lower limit of AVSS-0.3V and any current beyond 10mA for the analog input pins (LIN+/-, RIN+/-) should be avoided. Excessive currents to the input pins may damage the device. Hence input pins must be protected from signals at or beyond these limits. Use caution especially when using ± 15 V for other analog circuits in the system.

4. External Analog Circuit Examples

Figure 40 shows an input buffer circuit example 1. (1st order HPF; $f_c=0.795\text{Hz}$, 2nd order LPF; $f_c=438\text{kHz}$, gain=-9.63dB). The analog signal is able to input through XLR or BNC connectors. (short JP1 and JP2 for BNC input, open JP1 and JP2 for XLR input). The input level of this circuit is 17.0Vpp (AK5397: 5.6Vpp Typ.). When using this circuit, analog characteristics at $f_s=48\text{kHz}$ is DR=124dB, S/(N+D)=108dB.

Resistor values should be in $\pm 1\%$ accuracy.

When the bias voltage is more than $0.28 \times AVDD + 0.6$ [V], the internal diode is powered up.

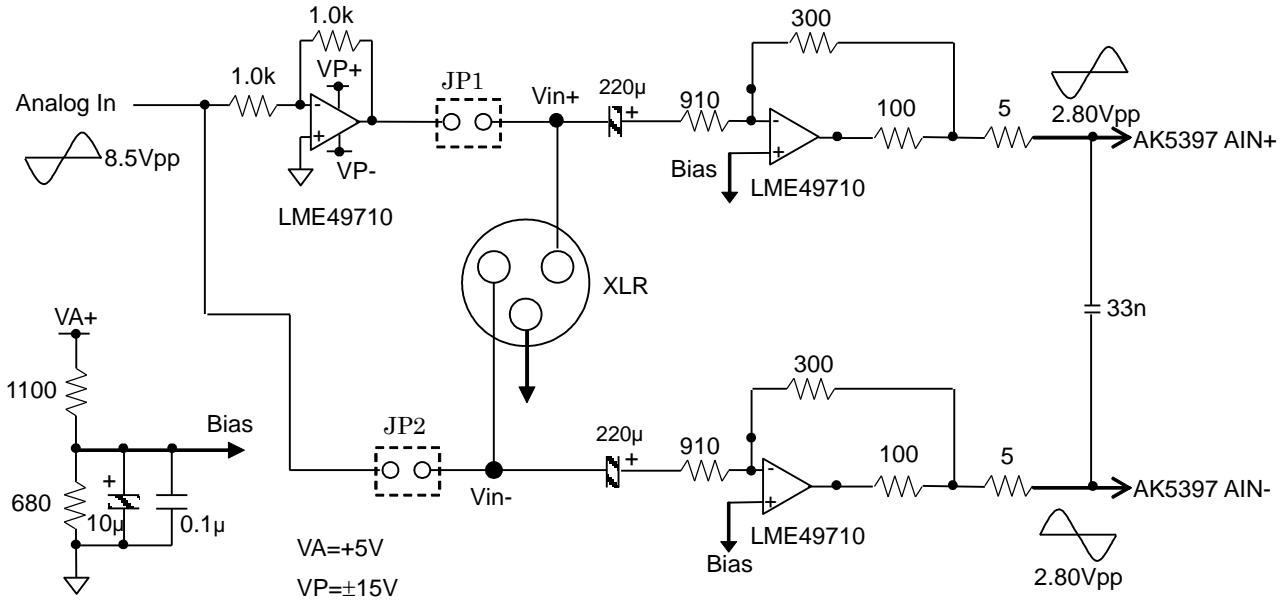

Figure 40. Analog Input Buffer Circuit Example 1

f_{in}	1Hz	10Hz
Frequency Response	-2.13dB	-0.03dB

Table 15. Frequency Response of HPF

f_{in}	20kHz	40kHz	80kHz	6.144MHz
Frequency Response	0.01dB	-0.04dB	-0.14dB	-30.31dB

Table 16. Frequency Response of LPF

Figure 41 shows an input buffer circuit example 1. (1st order HPF; $f_c=0.795\text{Hz}$, 2nd order LPF; $f_c=290\text{kHz}$, gain=963 dB). The analog signal is able to input through XLR or BNC connectors. (short JP1 and JP2 for BNC input, open JP1 and JP2 for XLR input). The input level of this circuit is 17.0Vpp (AK5397: 5.6Vpp Typ.). When using this circuit, analog characteristics at $f_s=48\text{kHz}$ is DR=127dB, S/(N+D)=100dB. Resistor values should be in $\pm 1\%$ accuracy. When the bias voltage is more than $0.28 \times AVDD + 0.6$ [V], the internal diode is powered up.

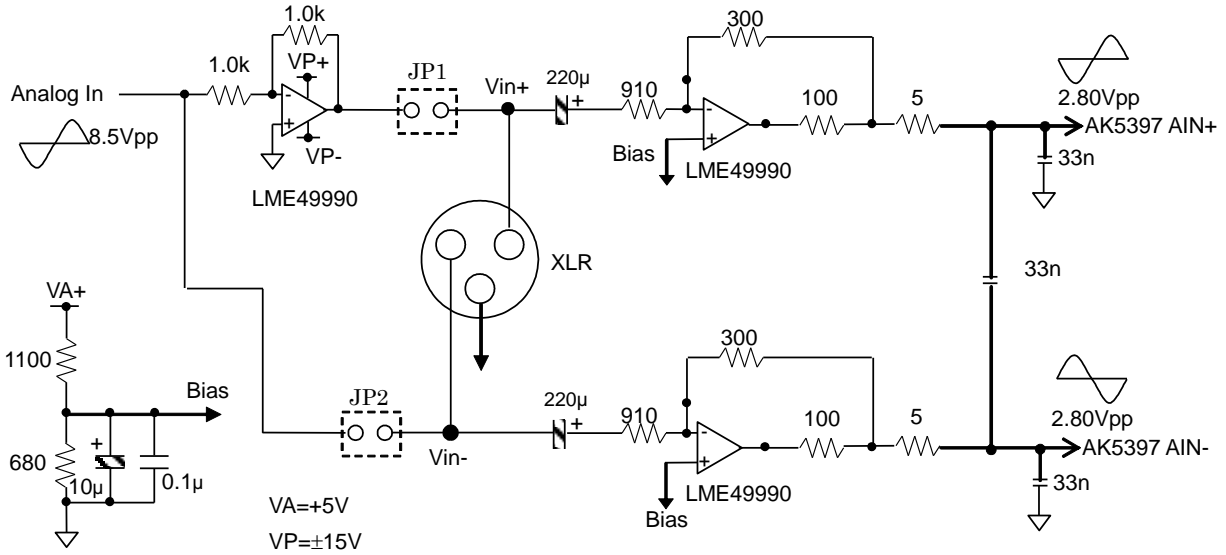

Figure 41. Analog Input Buffer Circuit Example 2

f_{in}	1Hz	10Hz
Frequency Response	-2.1dB	-0.03dB

Table 17. Frequency Response of HPF

f_{in}	20kHz	40kHz	80kHz	6.144MHz
Frequency Response	-0.01dB	-0.02dB	-0.08dB	-33.82dB

Table 18. Frequency Response of LPF

11. PACKAGE

■ Outline Dimensions

44pin LQFP (Unit: mm)

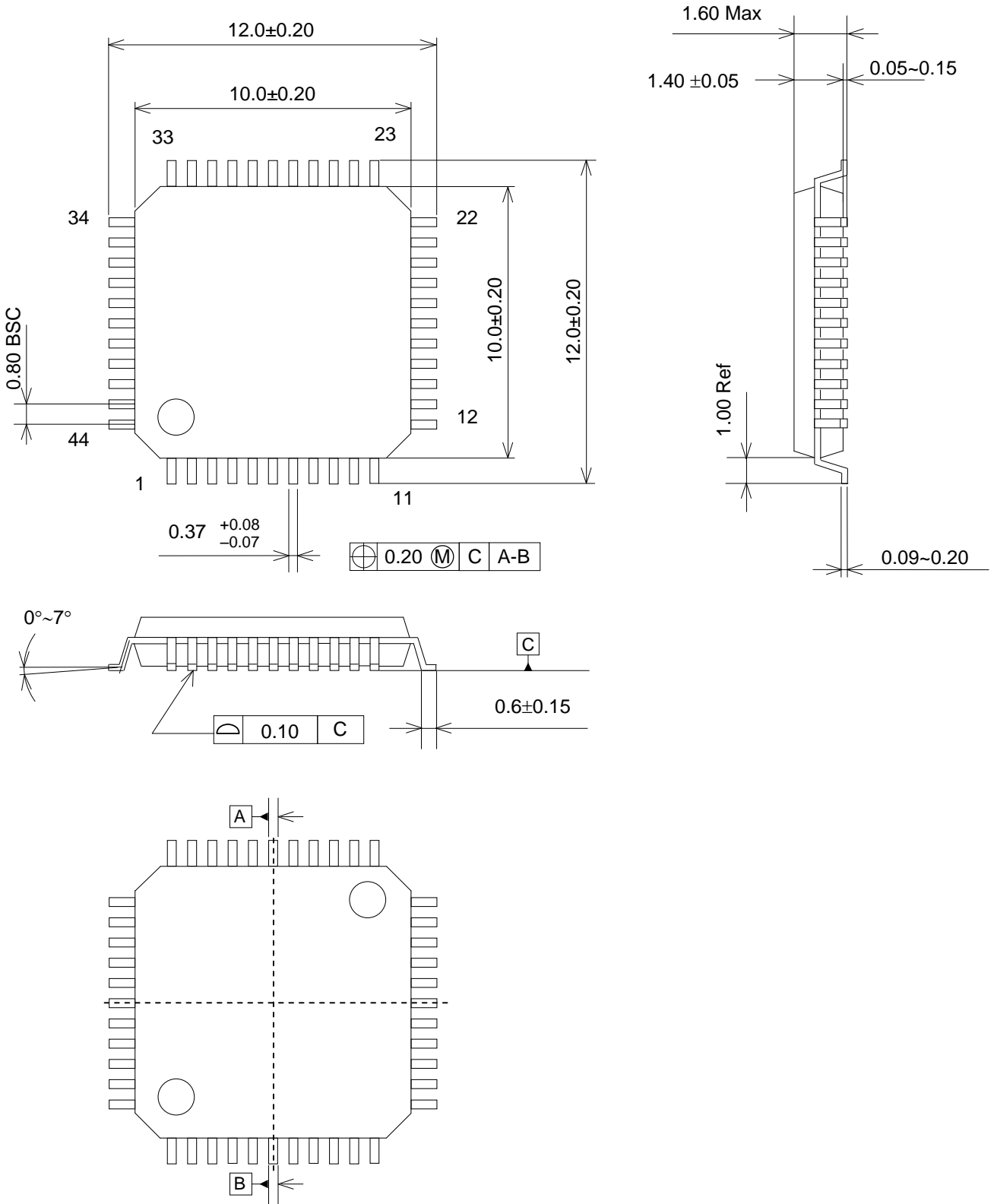

■ Material & Lead finish

Package molding compound: Epoxy, Halogen (bromine and chlorine) free
 Lead frame material: Cu
 Lead frame surface treatment: Solder (Pb free) plate

■ MARKING

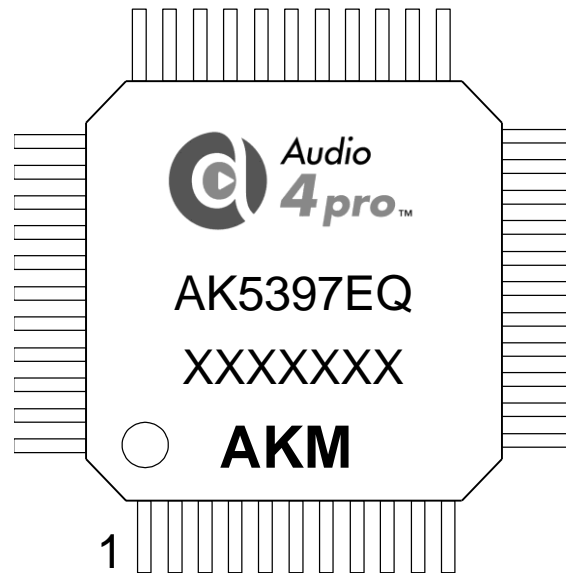

- 1) Pin #1 indication
- 2) Audio 4 pro Logo
- 3) Date Code: XXXXXXXX(7 digits)
- 4) Marking Code: AK5397
- 5) AKM Logo

12. Ordering Guide

AK5397EQ	-10 ~ +70°C	44pin LQFP (0.8mm pitch)
AKD5397	Evaluation Board for AK5397	

13. Revision History



Date (Y/M/D)	Revision	Reason	Page	Contents
14/11/14	00	First Edition		

IMPORTANT NOTICE





0. Asahi Kasei Microdevices Corporation ("AKM") reserves the right to make changes to the information contained in this document without notice. When you consider any use or application of AKM product stipulated in this document ("Product"), please make inquiries the sales office of AKM or authorized distributors as to current status of the Products.
1. All information included in this document are provided only to illustrate the operation and application examples of AKM Products. AKM neither makes warranties or representations with respect to the accuracy or completeness of the information contained in this document nor grants any license to any intellectual property rights or any other rights of AKM or any third party with respect to the information in this document. You are fully responsible for use of such information contained in this document in your product design or applications. AKM ASSUMES NO LIABILITY FOR ANY LOSSES INCURRED BY YOU OR THIRD PARTIES ARISING FROM THE USE OF SUCH INFORMATION IN YOUR PRODUCT DESIGN OR APPLICATIONS.
2. The Product is neither intended nor warranted for use in equipment or systems that require extraordinarily high levels of quality and/or reliability and/or a malfunction or failure of which may cause loss of human life, bodily injury, serious property damage or serious public impact, including but not limited to, equipment used in nuclear facilities, equipment used in the aerospace industry, medical equipment, equipment used for automobiles, trains, ships and other transportation, traffic signaling equipment, equipment used to control combustions or explosions, safety devices, elevators and escalators, devices related to electric power, and equipment used in finance-related fields. Do not use Product for the above use unless specifically agreed by AKM in writing.
3. Though AKM works continually to improve the Product's quality and reliability, you are responsible for complying with safety standards and for providing adequate designs and safeguards for your hardware, software and systems which minimize risk and avoid situations in which a malfunction or failure of the Product could cause loss of human life, bodily injury or damage to property, including data loss or corruption.
4. Do not use or otherwise make available the Product or related technology or any information contained in this document for any military purposes, including without limitation, for the design, development, use, stockpiling or manufacturing of nuclear, chemical, or biological weapons or missile technology products (mass destruction weapons). When exporting the Products or related technology or any information contained in this document, you should comply with the applicable export control laws and regulations and follow the procedures required by such laws and regulations. The Products and related technology may not be used for or incorporated into any products or systems whose manufacture, use, or sale is prohibited under any applicable domestic or foreign laws or regulations.
5. Please contact AKM sales representative for details as to environmental matters such as the RoHS compatibility of the Product. Please use the Product in compliance with all applicable laws and regulations that regulate the inclusion or use of controlled substances, including without limitation, the EU RoHS Directive. AKM assumes no liability for damages or losses occurring as a result of noncompliance with applicable laws and regulations.
6. Resale of the Product with provisions different from the statement and/or technical features set forth in this document shall immediately void any warranty granted by AKM for the Product and shall not create or extend in any manner whatsoever, any liability of AKM.
7. This document may not be reproduced or duplicated, in any form, in whole or in part, without prior written consent of AKM.

Looking for pricing, stock, or lifecycle information?

Click below to explore more details on WIN SOURCE:

-  [View AK5397EQ on WIN SOURCE](#)
-  [AKM Semiconductor Inc. Information](#)

Optimize Your Supply Chain with WIN SOURCE Solutions

-  Global Sourcing Solution
-  Obsolete Management
-  Cost Control Management
-  Shortage Management
-  Alternative Solution
-  Excess Inventory Management