



**THE DATASHEET OF  
AMC1305M25DW**



# AMC1305x

## High-Precision, Reinforced Isolated Delta-Sigma Modulators

### 1 Features

- Pin-Compatible Family Optimized for Shunt-Resistor-Based Current Measurements:
  - ±50-mV or ±250-mV Input Voltage Ranges
  - CMOS or LVDS Digital Interface Options
- Excellent DC Performance Supporting High-Precision Sensing on System Level:
  - Offset Error: ±50 μV or ±150 μV (max)
  - Offset Drift: 1.3 μV/°C (max)
  - Gain Error: ±0.3% (max)
  - Gain Drift: ±40 ppm/°C (max)
- Safety-Related Certifications:
  - 7000-V<sub>PK</sub> Reinforced Isolation per DIN V VDE V 0884-10 (VDE V 0884-10): 2006-12
  - 5000-V<sub>RMS</sub> Isolation for 1 Minute per UL1577
  - CAN/CSA No. 5A-Component Acceptance Service Notice, IEC 60950-1, and IEC 60065 End Equipment Standards
- Transient Immunity: 15 kV/μs (min)
- High Electromagnetic Field Immunity (see Application Note [SLLA181A](#))
- External 5-MHz to 20-MHz Clock Input for Easier System-Level Synchronization
- Fully Specified Over the Extended Industrial Temperature Range

### 2 Applications

- Shunt Resistor Based Current Sensing In:
  - Industrial Motor Drives
  - Photovoltaic Inverters
  - Uninterruptible Power Supplies
- Isolated Voltage Sensing

### 3 Description

The AMC1305 device is a precision, delta-sigma ( $\Delta\Sigma$ ) modulator with the output separated from the input circuitry by a capacitive double isolation barrier that is highly resistant to magnetic interference. This barrier is certified to provide reinforced isolation of up to 7000 V<sub>PEAK</sub> according to the DIN V VDE V 0884-10, UL1577, and CSA standards. Used in conjunction with isolated power supplies, the device prevents noise currents on a high common-mode voltage line from entering the local system ground and interfering with or damaging low voltage circuitry.

The AMC1305 is optimized for direct connection to shunt resistors or other low voltage level signal sources and supports excellent dc and ac performance. Shunt resistors are typically used to sense currents in motor drives, green energy generation systems, or other industrial applications. By using an appropriate digital filter (that is, as integrated on the [TMS320F2837x](#)) to decimate the bit stream, the device can achieve 16 bits of resolution with a dynamic range of 85 dB (13.8 ENOB) at a data rate of 78 kSPS.

On the high-side, the modulator is supplied with a nominal voltage of 5 V (AVDD), whereas the isolated digital interface operates from a 3.3-V or 5-V power supply (DVDD).

The AMC1305 is available in a wide-body SOIC-16 (DW) package and is specified from –40°C to +125°C.

#### Device Information<sup>(1)</sup>

PART NUMBER	PACKAGE	BODY SIZE (NOM)
AMC1305x	SOIC (16)	10.30 mm x 7.50 mm

(1) For all available packages, see the orderable addendum at the end of the datasheet.

#### Simplified Schematic

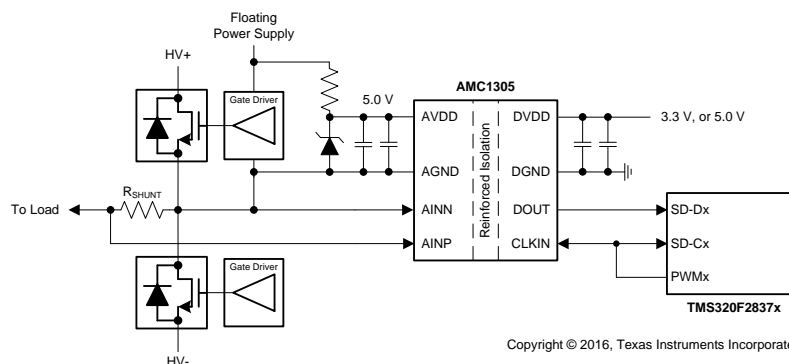

## Table of Contents

<b>1 Features</b> .....	<b>1</b>	8.1 Overview .....	<b>21</b>
<b>2 Applications</b> .....	<b>1</b>	8.2 Functional Block Diagram .....	<b>21</b>
<b>3 Description</b> .....	<b>1</b>	8.3 Feature Description .....	<b>22</b>
<b>4 Revision History</b> .....	<b>2</b>	8.4 Device Functional Modes .....	<b>24</b>
<b>5 Device Comparison Table</b> .....	<b>4</b>	<b>9 Application and Implementation</b> .....	<b>25</b>
<b>6 Pin Configurations and Functions</b> .....	<b>4</b>	9.1 Application Information .....	<b>25</b>
<b>7 Specifications</b> .....	<b>5</b>	9.2 Typical Applications .....	<b>26</b>
7.1 Absolute Maximum Ratings .....	<b>5</b>	<b>10 Power-Supply Recommendations</b> .....	<b>30</b>
7.2 ESD Ratings .....	<b>5</b>	<b>11 Layout</b> .....	<b>31</b>
7.3 Recommended Operating Conditions .....	<b>5</b>	11.1 Layout Guidelines .....	<b>31</b>
7.4 Thermal Information .....	<b>5</b>	11.2 Layout Examples .....	<b>31</b>
7.5 Power Ratings .....	<b>5</b>	<b>12 Device and Documentation Support</b> .....	<b>33</b>
7.6 Insulation Specifications .....	<b>6</b>	12.1 Documentation Support .....	<b>33</b>
7.7 Safety-Related Certifications .....	<b>7</b>	12.2 Related Links .....	<b>33</b>
7.8 Safety Limiting Values .....	<b>7</b>	12.3 Receiving Notification of Documentation Updates .....	<b>33</b>
7.9 Electrical Characteristics: AMC1305M05 .....	<b>8</b>	12.4 Community Resource .....	<b>33</b>
7.10 Electrical Characteristics: AMC1305x25 .....	<b>10</b>	12.5 Trademarks .....	<b>33</b>
7.11 Switching Characteristics .....	<b>12</b>	12.6 Electrostatic Discharge Caution .....	<b>33</b>
7.12 Insulation Characteristics Curves .....	<b>13</b>	12.7 Glossary .....	<b>34</b>
7.13 Typical Characteristics .....	<b>14</b>	<b>13 Mechanical, Packaging, and Orderable Information</b> .....	<b>34</b>
<b>8 Detailed Description</b> .....	<b>21</b>		

## 4 Revision History

NOTE: Page numbers for previous revisions may differ from page numbers in the current version.

<b>Changes from Revision E (January 2017) to Revision F</b>	<b>Page</b>
<ul style="list-style-type: none"> <li>Changed minimum specification from DGND – 0.3 to DGND – 0.5 and maximum specification from DVDD + 0.3 to DVDD + 0.5 in <i>Digital input voltage</i> parameter row of <i>Absolute Maximum Ratings</i> table .....</li> </ul>	<b>5</b>

<b>Changes from Revision D (August 2016) to Revision E</b>	<b>Page</b>
<ul style="list-style-type: none"> <li>Changed <math>V_{(ESD)}</math> for Human-body model (HBM) from <math>\pm 1000</math> V to <math>\pm 2500</math> V .....</li> </ul>	<b>5</b>

<b>Changes from Revision C (December 2014) to Revision D</b>	<b>Page</b>
<ul style="list-style-type: none"> <li>Added last two <i>Features</i> bullets .....</li> </ul>	<b>1</b>
<ul style="list-style-type: none"> <li>Changed <i>Simplified Schematic</i> figure .....</li> </ul>	<b>1</b>
<ul style="list-style-type: none"> <li>Moved <i>Power Rating</i>, <i>Insulation Specifications</i>, <i>Regulatory Information</i>, and <i>Safety Limiting Values</i> tables .....</li> </ul>	<b>5</b>
<ul style="list-style-type: none"> <li>Changed <i>Insulation Specifications</i> table as per ISO standard .....</li> </ul>	<b>6</b>
<ul style="list-style-type: none"> <li>Added <i>Insulation Characteristics Curves</i> section .....</li> </ul>	<b>13</b>
<ul style="list-style-type: none"> <li>Changed <a href="#">Figure 54</a> .....</li> </ul>	<b>26</b>
<ul style="list-style-type: none"> <li>Changed <a href="#">Figure 58</a> .....</li> </ul>	<b>30</b>

<b>Changes from Revision B (October 2014) to Revision C</b>	<b>Page</b>
<ul style="list-style-type: none"> <li>Changed device status of AMC1305M05 to Production Data .....</li> </ul>	<b>1</b>
<ul style="list-style-type: none"> <li>Changed document status from Mixed Status to Production Data .....</li> </ul>	<b>1</b>
<ul style="list-style-type: none"> <li>Updated ESD Ratings table to latest standard .....</li> </ul>	<b>5</b>

---

**Changes from Revision A (November 2014) to Revision B** **Page**

- Changed device status of AMC1305M25 to Production Data ..... 1
  - Changed Features bullet from "Safety and Regulatory Approvals" to "Safety-Related Certifications" ..... 1
- 

**Changes from Original (June 2014) to Revision A** **Page**

- Made changes to product preview data sheet..... 1
-

## 5 Device Comparison Table

PART NUMBER	INPUT VOLTAGE RANGE	DIFFERENTIAL INPUT RESISTANCE	SNR (sinc <sup>3</sup> Filter, 78 kSPS)	OUTPUT INTERFACE
AMC1305L25	±250 mV	25 kΩ	82 dB	LVDS
AMC1305M05	±50 mV	5 kΩ	76 dB	CMOS
AMC1305M25	±250 mV	25 kΩ	82 dB	CMOS

## 6 Pin Configurations and Functions

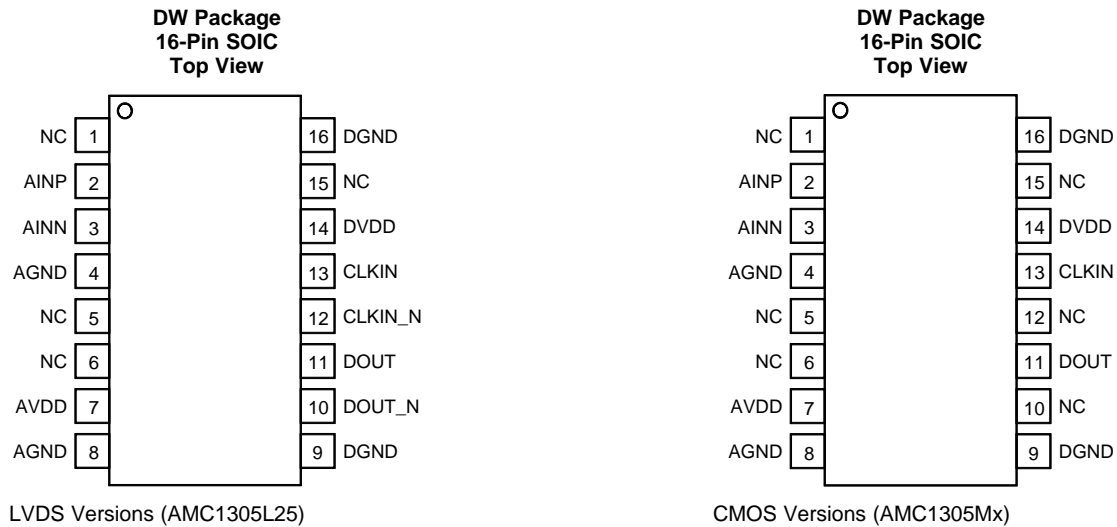

### Pin Functions

PIN		I/O	DESCRIPTION
NAME	NO.		
AGND	4	—	This pin is internally connected to pin 8 and can be left unconnected or tied to high-side ground
	8	—	High-side ground reference
AINN	3	I	Inverting analog input
AINP	2	I	Noninverting analog input
AVDD	7	—	High-side power supply, 4.5 V to 5.5 V. See the <a href="#">Power-Supply Recommendations</a> section for decoupling recommendations.
CLKIN	13	I	Modulator clock input, 5 MHz to 20.1 MHz
CLKIN_N	12	I	AMC1305L25 only: inverted modulator clock input
DGND	9, 16	—	Controller-side ground reference
DOUT	11	O	Modulator data output
DOUT_N	10	O	AMC1305L25 only: inverted modulator data output
DVDD	14	—	Controller-side power supply, 3.0 to 5.5 V
NC	1	—	This pin can be connected to AVDD or can be left unconnected
	5	—	This pin can be left unconnected or tied to AGND only
	6, 10, 12	—	These pins have no internal connection (pins 10 and 12 on the AMC1305Mx only).
	15	—	This pin can be left unconnected or tied to DVDD only

## 7 Specifications

### 7.1 Absolute Maximum Ratings

over the operating ambient temperature range (unless otherwise noted)<sup>(1)</sup>

	MIN	MAX	UNIT
Supply voltage, AVDD to AGND or DVDD to DGND	-0.3	6.5	V
Analog input voltage at AINP, AINN	AGND – 6	AVDD + 0.5	V
Digital input voltage at CLKIN, CLKIN_N	DGND – 0.5	DVDD + 0.5	V
Input current to any pin except supply pins	-10	10	mA
Maximum virtual junction temperature, T <sub>J</sub>		150	°C
Storage temperature, T <sub>stg</sub>	-65	150	°C

(1) Stresses beyond those listed under *Absolute Maximum Ratings* may cause permanent damage to the device. These are stress ratings only, and do not imply functional operation of the device at these or any other conditions beyond those indicated. Exposure to absolute-maximum-rated conditions for extended periods may affect device reliability.

### 7.2 ESD Ratings

		VALUE	UNIT
V <sub>(ESD)</sub> Electrostatic discharge	Human-body model (HBM), per ANSI/ESDA/JEDEC JS-001 <sup>(1)</sup>	±2500	V
	Charged-device model (CDM), per JEDEC specification JESD22-C101 <sup>(2)</sup>	±1000	

(1) JEDEC document JEP155 states that 500-V HBM allows safe manufacturing with a standard ESD control process.

(2) JEDEC document JEP157 states that 250-V CDM allows safe manufacturing with a standard ESD control process.

### 7.3 Recommended Operating Conditions

over operating free-air temperature range (unless otherwise noted)

		MIN	NOM	MAX	UNIT
AVDD	High-side (analog) supply voltage	4.5	5.0	5.5	V
DVDD	Controller-side (digital) supply voltage	3.0	3.3	5.5	V
T <sub>A</sub>	Operating ambient temperature range	-40		125	°C

### 7.4 Thermal Information

THERMAL METRIC <sup>(1)</sup>		AMC1305x	UNIT
		DW (SOIC)	
		16 PINS	
R <sub>θJA</sub>	Junction-to-ambient thermal resistance	80.2	°C/W
R <sub>θJC(top)</sub>	Junction-to-case (top) thermal resistance	40.5	°C/W
R <sub>θJB</sub>	Junction-to-board thermal resistance	45.1	°C/W
ψ <sub>JT</sub>	Junction-to-top characterization parameter	11.9	°C/W
ψ <sub>JB</sub>	Junction-to-board characterization parameter	44.5	°C/W
R <sub>θJC(bot)</sub>	Junction-to-case (bottom) thermal resistance	n/a	°C/W

(1) For more information about traditional and new thermal metrics, see the [Semiconductor and IC Package Thermal Metrics](#) application report.

### 7.5 Power Ratings

PARAMETER	TEST CONDITIONS	VALUE	UNIT	
P <sub>D</sub>	Maximum power dissipation (both sides)	AVDD = 5.5 V, DVDD = 5.5 V, LVDS, R <sub>LOAD</sub> = 100 Ω	89.1	mW
P <sub>D1</sub>	Maximum power dissipation (high-side supply)	AVDD = 5.5 V	45.1	mW
P <sub>D2</sub>	Maximum power dissipation (low-side supply)	DVDD = 5.5 V, LVDS, R <sub>LOAD</sub> = 100 Ω	44	mW

## 7.6 Insulation Specifications

PARAMETER		TEST CONDITIONS	VALUE	UNIT
<b>GENERAL</b>				
CLR	Minimum air gap (clearance) <sup>(1)</sup>	Shortest pin-to-pin distance through air	≥ 8	mm
CPG	Minimum external tracking (creepage) <sup>(1)</sup>	Shortest pin-to-pin distance across the package surface	≥ 8	mm
DTI	Distance through insulation	Minimum internal gap (internal clearance) of the double insulation (2 × 0.0135 mm)	0.027	mm
CTI	Comparative tracking index	DIN EN 60112 (VDE 0303-11); IEC 60112	≥ 600	V
	Material group	According to IEC 60664-1	I	
	Overvoltage category per IEC 60664-1	Rated mains voltage ≤ 300 V <sub>RMS</sub>	I-IV	
		Rated mains voltage ≤ 600 V <sub>RMS</sub>	I-III	
		Rated mains voltage ≤ 1000 V <sub>RMS</sub>	I-II	
<b>DIN V VDE V 0884-10 (VDE V 0884-10): 2006-12<sup>(2)</sup></b>				
V <sub>IORM</sub>	Maximum repetitive peak isolation voltage	At ac voltage (bipolar or unipolar)	1414	V <sub>PK</sub>
V <sub>IOWM</sub>	Maximum-rated isolation working voltage	At ac voltage (sine wave)	1000	V <sub>RMS</sub>
		At dc voltage	1500	V <sub>DC</sub>
V <sub>IOTM</sub>	Maximum transient isolation voltage	V <sub>TEST</sub> = V <sub>IOTM</sub> , t = 60 s (qualification test)	7000	V <sub>PK</sub>
		V <sub>TEST</sub> = 1.2 × V <sub>IOTM</sub> , t = 1 s (100% production test)	8400	
V <sub>IOSM</sub>	Maximum surge isolation voltage <sup>(3)</sup>	Test method per IEC 60065, 1.2/50-μs waveform, V <sub>TEST</sub> = 1.6 × V <sub>IOSM</sub> = 10000 V <sub>PK</sub> (qualification)	6250	V <sub>PK</sub>
q <sub>pd</sub>	Apparent charge <sup>(4)</sup>	Method a, after input/output safety test subgroup 2 / 3, V <sub>ini</sub> = V <sub>IOTM</sub> , t <sub>ini</sub> = 60 s, V <sub>pd(m)</sub> = 1.2 × V <sub>IORM</sub> = 1697 V <sub>PK</sub> , t <sub>m</sub> = 10 s	≤ 5	pC
		Method a, after environmental tests subgroup 1, V <sub>ini</sub> = V <sub>IOTM</sub> , t <sub>ini</sub> = 60 s, V <sub>pd(m)</sub> = 1.6 × V <sub>IORM</sub> = 2263 V <sub>PK</sub> , t <sub>m</sub> = 10 s	≤ 5	pC
		Method b1, at routine test (100% production) and preconditioning (type test), V <sub>ini</sub> = V <sub>IOTM</sub> , t <sub>ini</sub> = 1 s, V <sub>pd(m)</sub> = 1.875 × V <sub>IORM</sub> = 2652 V <sub>PK</sub> , t <sub>m</sub> = 1 s	≤ 5	pC
C <sub>IO</sub>	Barrier capacitance, input to output <sup>(5)</sup>	V <sub>IO</sub> = 0.5 V <sub>PP</sub> at 1 MHz	1.2	pF
R <sub>IO</sub>	Insulation resistance, input to output <sup>(5)</sup>	V <sub>IO</sub> = 500 V at T <sub>S</sub> = 150°C	> 10 <sup>9</sup>	Ω
	Pollution degree		2	
	Climatic category		40/125/21	
<b>UL1577</b>				
V <sub>ISO</sub>	Withstand isolation voltage	V <sub>TEST</sub> = V <sub>ISO</sub> = 5000 V <sub>RMS</sub> or 7000 V <sub>DC</sub> , t = 60 s (qualification test), V <sub>TEST</sub> = 1.2 × V <sub>ISO</sub> = 6000 V <sub>RMS</sub> , t = 1 s (100% production test)	5000	V <sub>RMS</sub>

- (1) Apply creepage and clearance requirements according to the specific equipment isolation standards of an application. Care must be taken to maintain the creepage and clearance distance of a board design to ensure that the mounting pads of the isolator on the printed circuit board (PCB) do not reduce this distance. Creepage and clearance on a PCB become equal in certain cases. Techniques such as inserting grooves or ribs on the PCB are used to help increase these specifications.
- (2) This coupler is suitable for *safe electrical insulation* only within the safety ratings. Compliance with the safety ratings shall be ensured by means of suitable protective circuits.
- (3) Testing is carried out in air or oil to determine the intrinsic surge immunity of the isolation barrier.
- (4) Apparent charge is electrical discharge caused by a partial discharge (pd).
- (5) All pins on each side of the barrier are tied together, creating a two-pin device.

## 7.7 Safety-Related Certifications

VDE	UL
Certified according to DIN V VDE V 0884-10 (VDE V 0884-10): 2006-12, DIN EN 60950-1 (VDE 0805 Teil 1): 2014-08, and DIN EN 60095 (VDE 0860): 2005-11	Recognized under UL1577 component recognition and CSA component acceptance NO 5 programs
Reinforced insulation	Single protection
File number: 40040142	File number: E181974

## 7.8 Safety Limiting Values

Safety limiting intends to prevent potential damage to the isolation barrier upon failure of input or output (I/O) circuitry. A failure of the I/O circuitry may allow low resistance to ground or the supply and, without current limiting, dissipate sufficient power to overheat the die and damage the isolation barrier, potentially leading to secondary system failures.

PARAMETER	TEST CONDITIONS	MIN	TYP	MAX	UNIT
I <sub>S</sub> Safety input, output, or supply current	$\theta_{JA} = 80.2^{\circ}\text{C/W}$ , AVDD = DVDD = 5.5 V, T <sub>J</sub> = 150°C, T <sub>A</sub> = 25°C, see <a href="#">Figure 3</a>			283	mA
	$\theta_{JA} = 80.2^{\circ}\text{C/W}$ , AVDD = DVDD = 3.6 V, T <sub>J</sub> = 150°C, T <sub>A</sub> = 25°C, see <a href="#">Figure 3</a>			432	mA
P <sub>S</sub> Safety input, output, or total power	$\theta_{JA} = 80.2^{\circ}\text{C/W}$ , T <sub>J</sub> = 150°C, T <sub>A</sub> = 25°C, see <a href="#">Figure 4</a>			1558 <sup>(1)</sup>	mW
T <sub>S</sub> Maximum safety temperature				150	°C

(1) Input, output, or the sum of input and output power must not exceed this value.

The maximum safety temperature is the maximum junction temperature specified for the device. The power dissipation and junction-to-air thermal impedance of the device installed in the application hardware determines the junction temperature. The assumed junction-to-air thermal resistance in the [Thermal Information](#) table is that of a device installed on a high-K test board for leaded surface-mount packages. The power is the recommended maximum input voltage times the current. The junction temperature is then the ambient temperature plus the power times the junction-to-air thermal resistance.

## 7.9 Electrical Characteristics: AMC1305M05

All minimum and maximum specifications at  $T_A = -40^\circ\text{C}$  to  $+125^\circ\text{C}$ ,  $AVDD = 4.5\text{ V}$  to  $5.5\text{ V}$ ,  $DVDD = 3.0\text{ V}$  to  $5.5\text{ V}$ ,  $AINP = -50\text{ mV}$  to  $50\text{ mV}$ ,  $AINN = 0\text{ V}$ , and sinc<sup>3</sup> filter with OSR = 256, unless otherwise noted. Typical values are at  $T_A = 25^\circ\text{C}$ ,  $CLKIN = 20\text{ MHz}$ ,  $AVDD = 5.0\text{ V}$ , and  $DVDD = 3.3\text{ V}$ .

PARAMETER		TEST CONDITIONS	MIN	TYP	MAX	UNIT
<b>ANALOG INPUTS</b>						
$V_{\text{Clipping}}$	Maximum differential voltage input range (AINP-AINN)			±62.5		mV
FSR	Specified linear full-scale range (AINP-AINN)		-50		50	mV
$V_{\text{CM}}$	Operating common-mode input range		-0.032		$AVDD - 2$	V
$C_{\text{ID}}$	Differential input capacitance			2		pF
$I_{\text{IB}}$	Input current	Inputs shorted to AGND	-97	-72	-57	µA
$R_{\text{ID}}$	Differential input resistance			5		kΩ
$I_{\text{OS}}$	Input offset current			±5		nA
CMTI	Common-mode transient immunity		15			kV/µs
CMRR	Common-mode rejection ratio	$f_{\text{IN}} = 0\text{ Hz}$ , $V_{\text{CM min}} \leq V_{\text{IN}} \leq V_{\text{CM max}}$		-104		dB
		$f_{\text{IN}}$ from 0.1 Hz to 50 kHz, $V_{\text{CM min}} \leq V_{\text{IN}} \leq V_{\text{CM max}}$		-75		
BW	Input bandwidth			800		kHz
<b>DC ACCURACY</b>						
DNL	Differential nonlinearity	Resolution: 16 bits	-0.99		0.99	LSB
INL	Integral nonlinearity <sup>(1)</sup>	Resolution: 16 bits	-4	±1.5	4	LSB
$E_{\text{O}}$	Offset error	Initial, at 25°C	-50	±2.5	50	µV
$TCE_{\text{O}}$	Offset error thermal drift <sup>(2)</sup>		-1.3		1.3	µV/°C
$E_{\text{G}}$	Gain error	Initial, at 25°C	-0.3%	-0.02%	0.3%	
$TCE_{\text{G}}$	Gain error thermal drift <sup>(3)</sup>		-40	±20	40	ppm/°C
PSRR	Power-supply rejection ratio	$V_{\text{AVDD}}$ from 4.5 to 5.5V, at dc		105		dB
<b>AC ACCURACY</b>						
SNR	Signal-to-noise ratio	$f_{\text{IN}} = 1\text{ kHz}$	76	81		dB
SINAD	Signal-to-noise + distortion	$f_{\text{IN}} = 1\text{ kHz}$	76	81		dB
THD	Total harmonic distortion	$f_{\text{IN}} = 1\text{ kHz}$		-90	-83	dB
SFDR	Spurious-free dynamic range	$f_{\text{IN}} = 1\text{ kHz}$	83	92		dB
<b>DIGITAL INPUTS/OUTPUTS</b>						
<b>External Clock</b>						
$f_{\text{CLKIN}}$	Input clock frequency		5	20	20.1	MHz
Duty <sub>CLKIN</sub>	Duty cycle	$5\text{ MHz} \leq f_{\text{CLKIN}} \leq 20.1\text{ MHz}$	40%	50%	60%	
<b>CMOS Logic Family, CMOS with Schmitt-Trigger</b>						
$I_{\text{IN}}$	Input current	$DGND \leq V_{\text{IN}} \leq DVDD$	-1		1	µA
$C_{\text{IN}}$	Input capacitance			5		pF
$V_{\text{IH}}$	High-level input voltage		$0.7 \times DVDD$		$DVDD + 0.3$	V
$V_{\text{IL}}$	Low-level input voltage		-0.3		$0.3 \times DVDD$	V
$C_{\text{LOAD}}$	Output load capacitance	$f_{\text{CLKIN}} = 20\text{ MHz}$		30		pF
$V_{\text{OH}}$	High-level output voltage	$I_{\text{OH}} = -20\text{ µA}$	$DVDD - 0.1$			V
		$I_{\text{OH}} = -4\text{ mA}$	$DVDD - 0.4$			
$V_{\text{OL}}$	Low-level output voltage	$I_{\text{OL}} = 20\text{ µA}$			0.1	V
		$I_{\text{OL}} = 4\text{ mA}$			0.4	

(1) Integral nonlinearity is defined as the maximum deviation from a straight line passing through the end-points of the ideal ADC transfer function expressed as number of LSBs or as a percent of the specified linear full-scale range FSR.

(2) Offset error drift is calculated using the box method as described by the following equation:

$$TCE_{\text{O}} = \frac{\text{value}_{\text{MAX}} - \text{value}_{\text{MIN}}}{\text{TempRange}}$$

(3) Gain error drift is calculated using the box method as described by the following equation:

$$TCE_{\text{G}} (\text{ppm}) = \left( \frac{\text{value}_{\text{MAX}} - \text{value}_{\text{MIN}}}{\text{value} \times \text{TempRange}} \right) \times 10^6$$

**Electrical Characteristics: AMC1305M05 (continued)**

All minimum and maximum specifications at  $T_A = -40^{\circ}\text{C}$  to  $+125^{\circ}\text{C}$ ,  $AVDD = 4.5\text{ V}$  to  $5.5\text{ V}$ ,  $DVDD = 3.0\text{ V}$  to  $5.5\text{ V}$ ,  $A\text{INP} = -50\text{ mV}$  to  $50\text{ mV}$ ,  $A\text{INN} = 0\text{ V}$ , and sinc<sup>3</sup> filter with  $\text{OSR} = 256$ , unless otherwise noted. Typical values are at  $T_A = 25^{\circ}\text{C}$ ,  $\text{CLKIN} = 20\text{ MHz}$ ,  $AVDD = 5.0\text{ V}$ , and  $DVDD = 3.3\text{ V}$ .

PARAMETER		TEST CONDITIONS	MIN	TYP	MAX	UNIT
<b>POWER SUPPLY</b>						
AVDD	High-side supply voltage		4.5	5.0	5.5	V
I <sub>AVDD</sub>	High-side supply current			6.5	8.2	mA
P <sub>AVDD</sub>	High-side power dissipation			32.5	45.1	mW
DVDD	Controller-side supply voltage		3.0	3.3	5.5	V
I <sub>DVDD</sub>	Controller-side supply current	3.0 V ≤ DVDD ≤ 3.6 V		2.7	4.0	mA
		4.5 V ≤ DVDD ≤ 5.5 V		3.2	5.5	
P <sub>DVDD</sub>	Controller-side power dissipation	3.0 V ≤ DVDD ≤ 3.6 V		8.9	14.4	mW
		4.5 V ≤ DVDD ≤ 5.5 V		16.0	30.3	

## 7.10 Electrical Characteristics: AMC1305x25

All minimum and maximum specifications at  $T_A = -40^\circ\text{C}$  to  $125^\circ\text{C}$ ,  $AVDD = 4.5\text{ V}$  to  $5.5\text{ V}$ ,  $DVDD = 3.0\text{ V}$  to  $5.5\text{ V}$ ,  $AINP = -250\text{ mV}$  to  $250\text{ mV}$ ,  $AINN = 0\text{ V}$ , and sinc<sup>3</sup> filter with  $OSR = 256$ , unless otherwise noted. Typical values are at  $T_A = 25^\circ\text{C}$ ,  $CLKIN = 20\text{ MHz}$ ,  $AVDD = 5.0\text{ V}$ , and  $DVDD = 3.3\text{ V}$ .

PARAMETER		TEST CONDITIONS	MIN	TYP	MAX	UNIT
<b>ANALOG INPUTS</b>						
$V_{Clipping}$	Maximum differential voltage input range (AINP-AINN)			$\pm 312.5$		mV
FSR	Specified linear full-scale range (AINP-AINN)		-250		250	mV
$V_{CM}$	Operating common-mode input range		-0.16		$AVDD - 2$	V
$C_{ID}$	Differential input capacitance			1		pF
$I_{IB}$	Input current	Inputs shorted to AGND	-82	-60	-48	$\mu\text{A}$
$R_{ID}$	Differential input resistance			25		k $\Omega$
$I_{OS}$	Input offset current			$\pm 5$		nA
CMTI	Common-mode transient immunity		15			kV/ $\mu\text{s}$
CMRR	Common-mode rejection ratio	$f_{IN} = 0\text{ Hz}$ , $V_{CM\ min} \leq V_{IN} \leq V_{CM\ max}$		-95		dB
		$f_{IN}$ from 0.1 Hz to 50 kHz, $V_{CM\ min} \leq V_{IN} \leq V_{CM\ max}$		-76		
BW	Input bandwidth			1000		kHz
<b>DC ACCURACY</b>						
DNL	Differential nonlinearity	Resolution: 16 bits	-0.99		0.99	LSB
INL	Integral nonlinearity <sup>(1)</sup>	Resolution: 16 bits	-4	$\pm 1.5$	4	LSB
$E_O$	Offset error	Initial, at $25^\circ\text{C}$	-150	$\pm 40$	150	$\mu\text{V}$
$TCE_O$	Offset error thermal drift <sup>(2)</sup>		-1.3		1.3	$\mu\text{V}/^\circ\text{C}$
$E_G$	Gain error	Initial, at $25^\circ\text{C}$	-0.3	-0.02	0.3	%FS
$TCE_G$	Gain error thermal drift <sup>(3)</sup>		-40	$\pm 20$	40	ppm/ $^\circ\text{C}$
PSRR	Power-supply rejection ratio	$V_{AVDD}$ from 4.5 V to 5.5 V, at dc		90		dB
<b>AC ACCURACY</b>						
SNR	Signal-to-noise ratio	$f_{IN} = 1\text{ kHz}$	82	85		dB
SINAD	Signal-to-noise + distortion	$f_{IN} = 1\text{ kHz}$	80	84		dB
THD	Total harmonic distortion	$f_{IN} = 1\text{ kHz}$		-90	-83	dB
SFDR	Spurious-free dynamic range	$f_{IN} = 1\text{ kHz}$	83	92		dB
<b>DIGITAL INPUTS/OUTPUTS</b>						
<b>External Clock</b>						
$f_{CLKIN}$	Input clock frequency		5	20	20.1	MHz
Duty <sub>CLKIN</sub>	Duty cycle	$5\text{ MHz} \leq f_{CLKIN} \leq 20.1\text{ MHz}$	40%	50%	60%	
<b>CMOS Logic Family (AMC1305M25), CMOS with Schmitt-Trigger</b>						
$I_{IN}$	Input current	$DGND \leq V_{IN} \leq DVDD$	-1		1	$\mu\text{A}$
$C_{IN}$	Input capacitance			5		pF
$V_{IH}$	High-level input voltage		$0.7 \times DVDD$		$DVDD + 0.3$	V
$V_{IL}$	Low-level input voltage		-0.3		$0.3 \times DVDD$	V
$C_{LOAD}$	Output load capacitance	$f_{CLKIN} = 20\text{ MHz}$		30		pF
$V_{OH}$	High-level output voltage	$I_{OH} = -20\ \mu\text{A}$	$DVDD - 0.1$			V
		$I_{OH} = -4\ \text{mA}$	$DVDD - 0.4$			
$V_{OL}$	Low-level output voltage	$I_{OL} = 20\ \mu\text{A}$			0.1	V
		$I_{OL} = 4\ \text{mA}$			0.4	

(1) Integral nonlinearity is defined as the maximum deviation from a straight line passing through the end-points of the ideal ADC transfer function expressed as the number of LSBs or as a percent of the specified linear full-scale range FSR.

(2) Offset error drift is calculated using the box method as described by the following equation:

$$TCE_O = \frac{value_{MAX} - value_{MIN}}{TempRange}$$

(3) Gain error drift is calculated using the box method as described by the following equation:

$$TCE_G (ppm) = \left( \frac{value_{MAX} - value_{MIN}}{value \times TempRange} \right) \times 10^6$$

**Electrical Characteristics: AMC1305x25 (continued)**

All minimum and maximum specifications at  $T_A = -40^\circ\text{C}$  to  $125^\circ\text{C}$ ,  $AVDD = 4.5\text{ V}$  to  $5.5\text{ V}$ ,  $DVDD = 3.0\text{ V}$  to  $5.5\text{ V}$ ,  $A_{INP} = -250\text{ mV}$  to  $250\text{ mV}$ ,  $A_{INN} = 0\text{ V}$ , and sinc<sup>3</sup> filter with  $OSR = 256$ , unless otherwise noted. Typical values are at  $T_A = 25^\circ\text{C}$ ,  $CLKIN = 20\text{ MHz}$ ,  $AVDD = 5.0\text{ V}$ , and  $DVDD = 3.3\text{ V}$ .

PARAMETER		TEST CONDITIONS	MIN	TYP	MAX	UNIT
<b>LVDS Logic Family (AMC1305L25)</b>						
$V_{OD}$	Differential output voltage	$R_{LOAD} = 100\ \Omega$	250	350	450	mV
$V_{OCM}$	Output common-mode voltage		1.125	1.23	1.375	V
$I_S$	Output short-circuit current				24	mA
$V_{ICM}$	Input common-mode voltage	$V_{ID} = 100\text{ mV}$	0.05	1.25	3.25	V
$V_{ID}$	Differential input voltage		100	350	600	mV
$I_{IN}$	Input current	$DGND \leq V_{IN} \leq 3.3\text{ V}$	-24	0	20	$\mu\text{A}$
<b>POWER SUPPLY</b>						
$AVDD$	High-side supply voltage		4.5	5.0	5.5	V
$I_{AVDD}$	High-side supply current			6.5	8.2	mA
$P_{AVDD}$	High-side power dissipation			32.5	45.1	mW
$DVDD$	Controller-side supply voltage		3.0	3.3	5.5	V
$I_{DVDD}$	Controller-side supply current	AMC1305L25, $R_{LOAD} = 100\ \Omega$		6.1	8.0	mA
		AMC1305M25, $3.0 \leq DVDD \leq 3.6\text{ V}$ , $C_{LOAD} = 5\text{ pF}$		2.7	4.0	
		AMC1305M25, $4.5 \leq DVDD \leq 5.5\text{ V}$ , $C_{LOAD} = 5\text{ pF}$		3.2	5.5	
$P_{DVDD}$	Controller-side power dissipation	AMC1305L25, $R_{LOAD} = 100\ \Omega$		20.1	44.0	mW
		AMC1305M25, $3.0 \leq DVDD \leq 3.6\text{ V}$ , $C_{LOAD} = 5\text{ pF}$		8.9	14.4	
		AMC1305M25, $4.5 \leq DVDD \leq 5.5\text{ V}$ , $C_{LOAD} = 5\text{ pF}$		16.0	30.3	

## 7.11 Switching Characteristics

over operating free-air temperature range (unless otherwise noted)

PARAMETER		MIN	TYP	MAX	UNIT
$t_{CLK}$	CLKIN, CLKIN_N clock period	49.75	50	200	ns
$t_{HIGH}$	CLKIN, CLKIN_N clock high time	19.9	25	120	ns
$t_{LOW}$	CLKIN, CLKIN_N clock low time	19.9	25	120	ns
$t_D$	Falling edge of CLKIN, CLKIN_N to DOUT, DOUT_N valid delay, $C_{LOAD} = 5$ pF	0		15	ns
$t_{iSTART}$	Interface startup time (DVDD at 3.0 V min to DOUT, DOUT_N valid with $AVDD \geq 4.5$ V)	32		32	CLKIN cycles
$t_{ASTART}$	Analog startup time (AVDD step up to 4.5 V with $DVDD \geq 3.0$ V)		1		ms

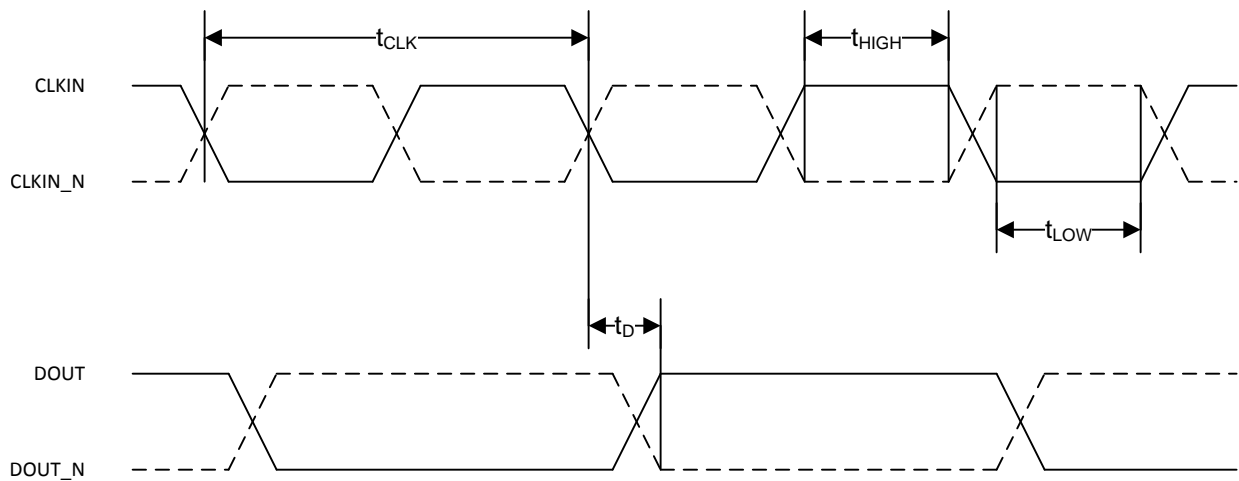
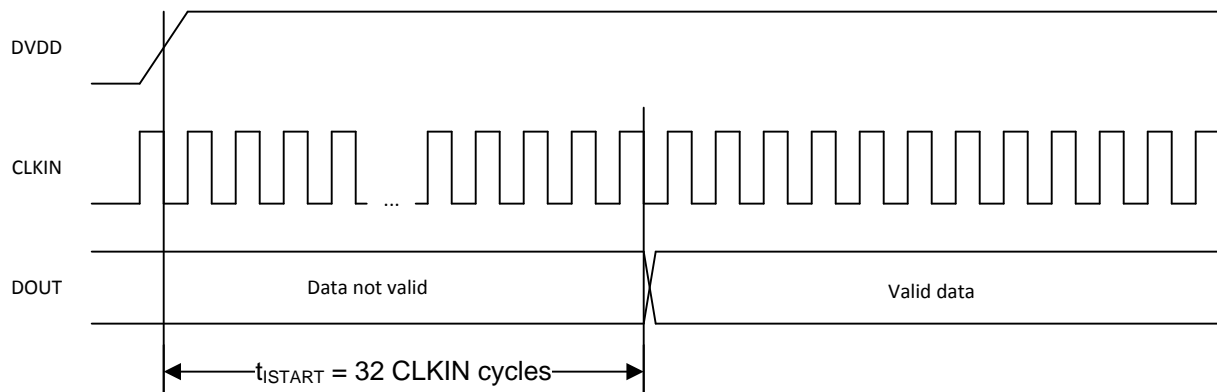
**Figure 1. Digital Interface Timing**

**Figure 2. Digital Interface Startup Timing**

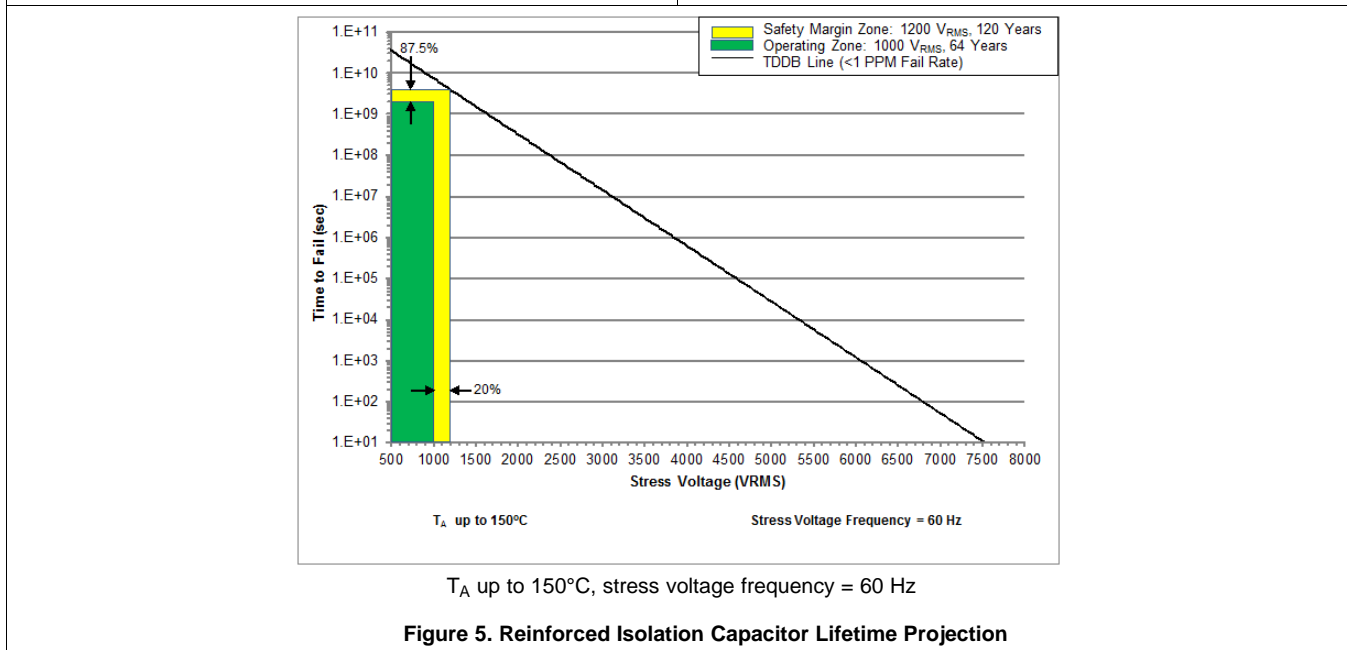
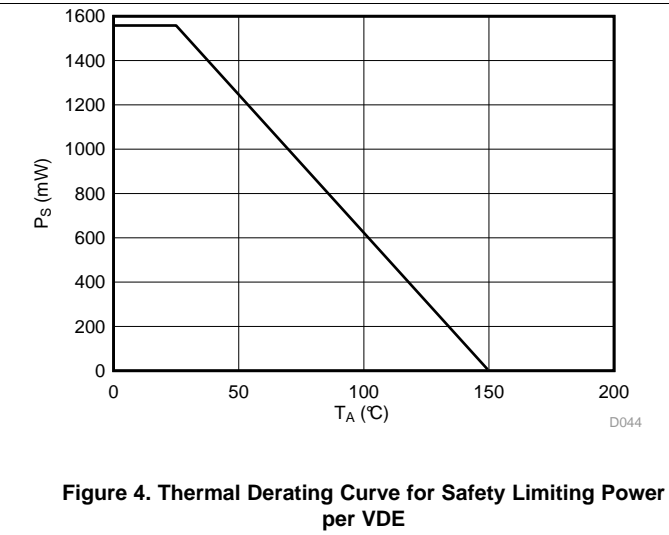
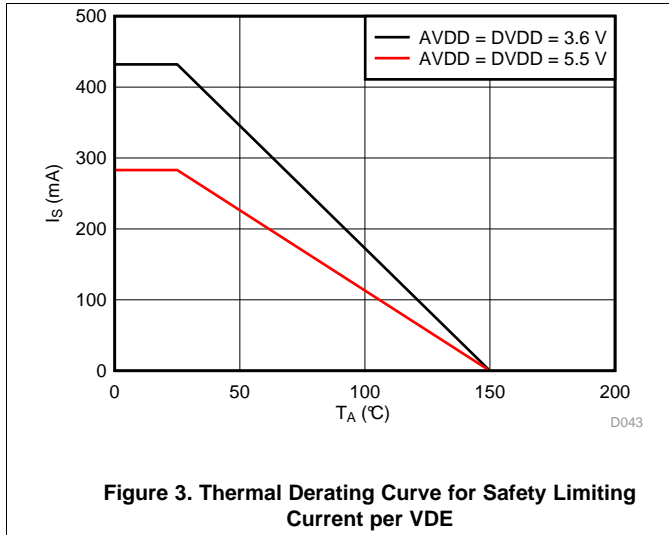
### 7.12 Insulation Characteristics Curves



### 7.13 Typical Characteristics

At  $T_A = 25^\circ\text{C}$ ,  $AV_{DD} = 5.0\text{ V}$ ,  $DV_{DD} = 3.3\text{ V}$ ,  $A_{INP} = -250\text{ mV}$  to  $250\text{ mV}$ ,  $A_{INN} = 0\text{ V}$ ,  $f_{CLKIN} = 20\text{ MHz}$ , and sinc<sup>3</sup> filter with OSR = 256, unless otherwise noted.

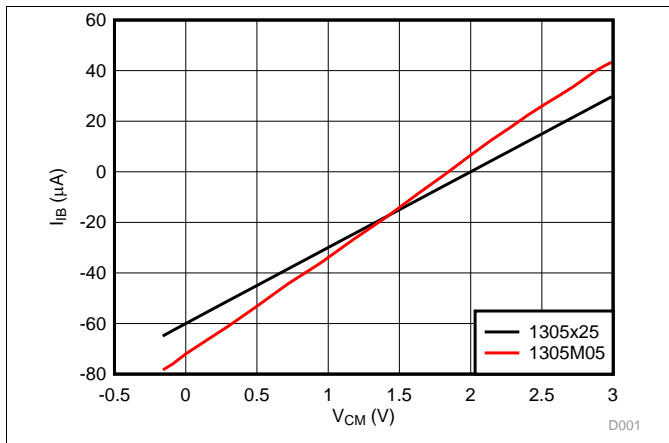

Figure 6. Input Current vs Input Common-Mode Voltage

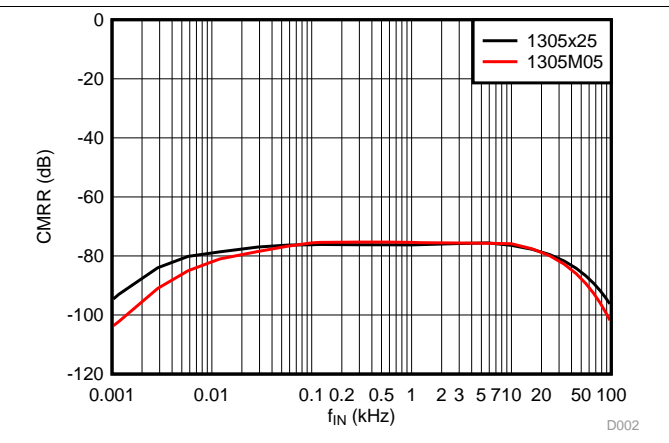

Figure 7. Common-Mode Rejection Ratio vs Input Signal Frequency

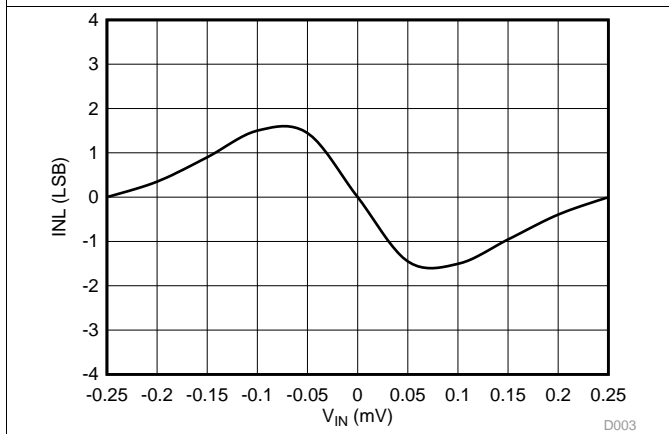

Figure 8. Integral Nonlinearity vs Input Signal Amplitude

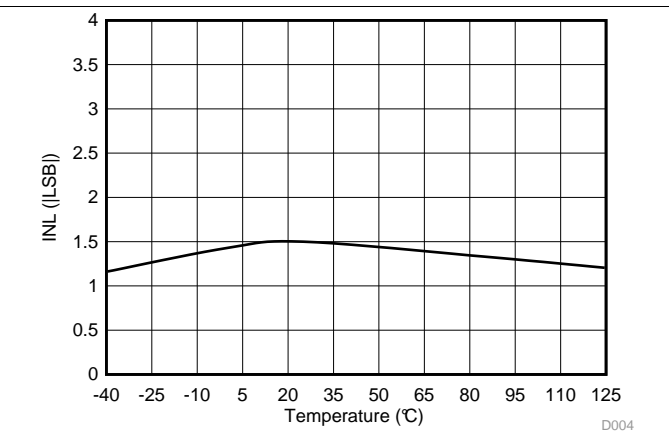

Figure 9. Integral Nonlinearity vs Temperature

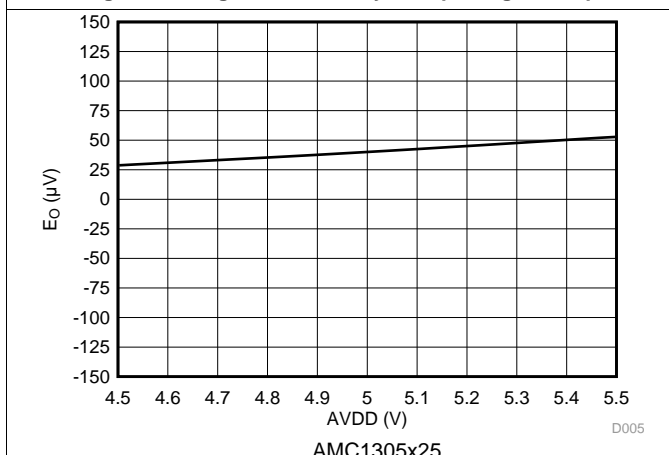

Figure 10. Offset Error vs High-Side Supply Voltage

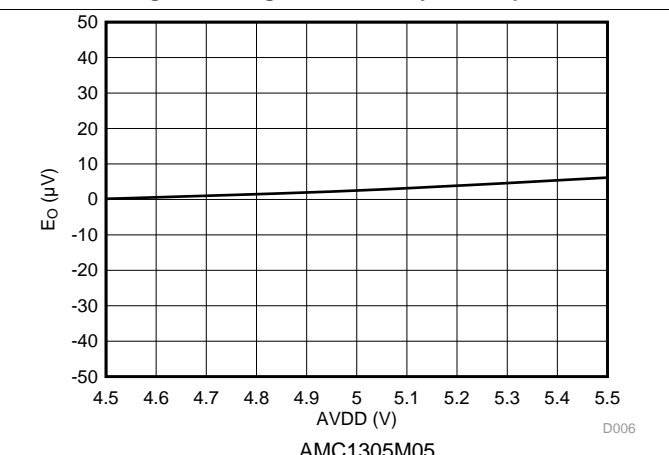
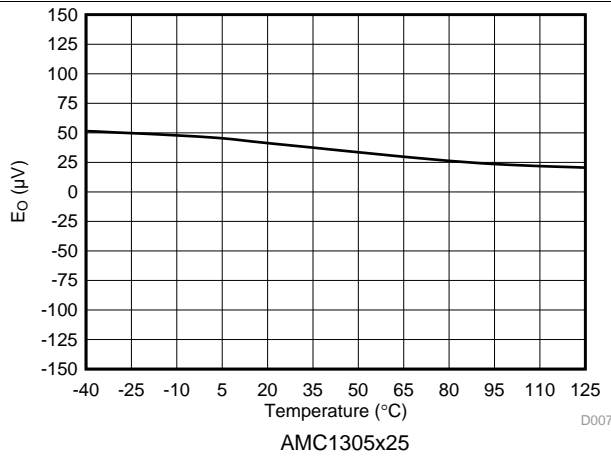

Figure 11. Offset Error vs High-Side Supply Voltage

**Typical Characteristics (continued)**

At  $T_A = 25^\circ\text{C}$ ,  $AVDD = 5.0\text{ V}$ ,  $DVDD = 3.3\text{ V}$ ,  $A\text{INP} = -250\text{ mV to }250\text{ mV}$ ,  $A\text{INN} = 0\text{ V}$ ,  $f_{\text{CLKIN}} = 20\text{ MHz}$ , and sinc<sup>3</sup> filter with OSR = 256, unless otherwise noted.



**Figure 12. Offset Error vs Temperature**

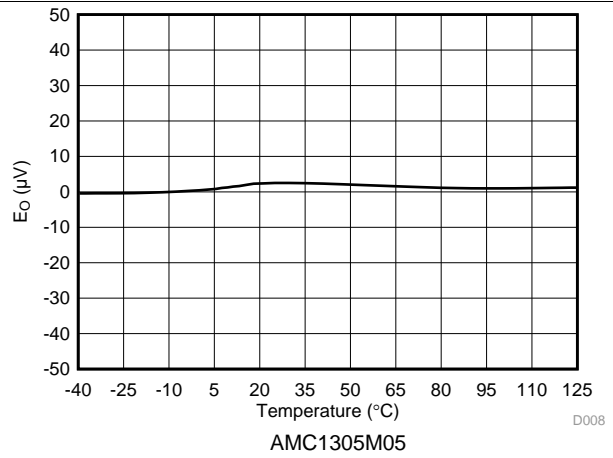

**Figure 13. Offset Error vs Temperature**

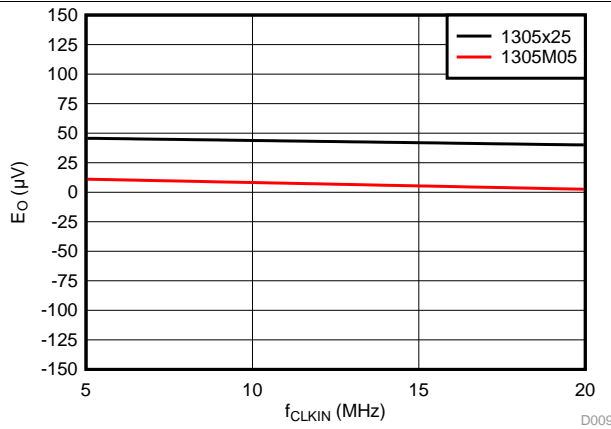

**Figure 14. Offset Error vs Clock Frequency**

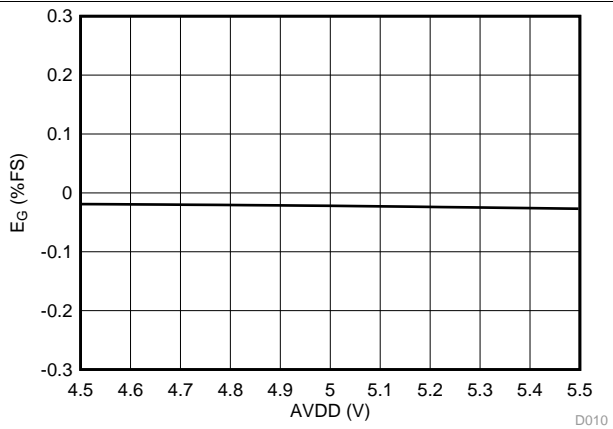

**Figure 15. Gain Error vs High-Side Supply Voltage**

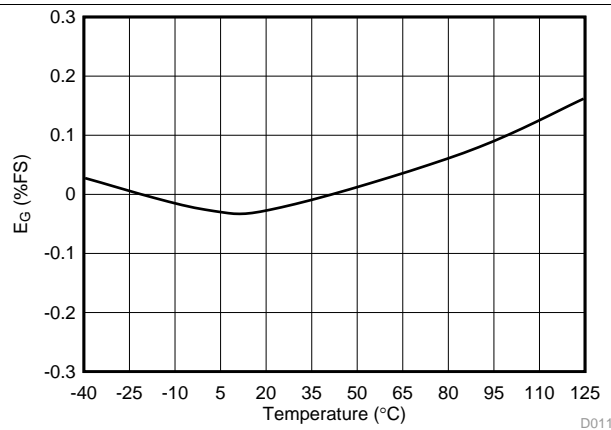

**Figure 16. Gain Error vs Temperature**

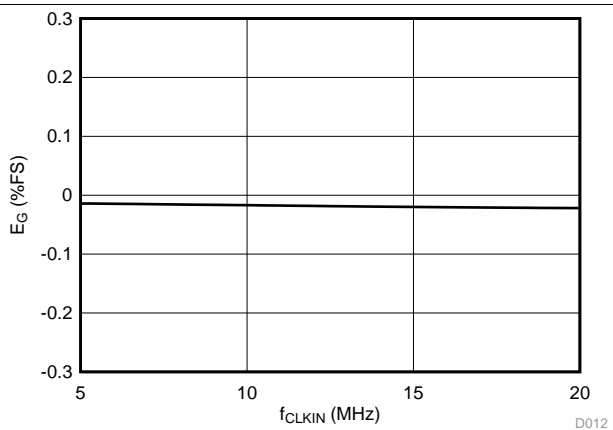

**Figure 17. Gain Error vs Clock Frequency**

**Typical Characteristics (continued)**

At  $T_A = 25^\circ\text{C}$ ,  $AVDD = 5.0\text{ V}$ ,  $DVDD = 3.3\text{ V}$ ,  $A\text{INP} = -250\text{ mV to }250\text{ mV}$ ,  $A\text{INN} = 0\text{ V}$ ,  $f_{\text{CLKIN}} = 20\text{ MHz}$ , and sinc<sup>3</sup> filter with OSR = 256, unless otherwise noted.

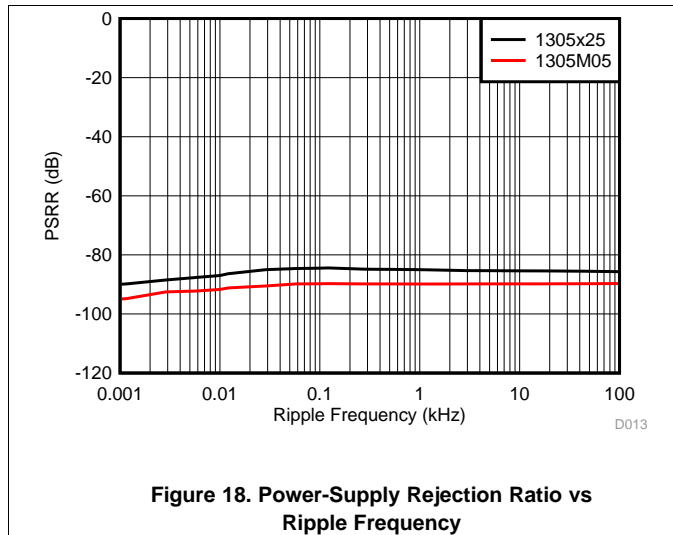

**Figure 18. Power-Supply Rejection Ratio vs Ripple Frequency**

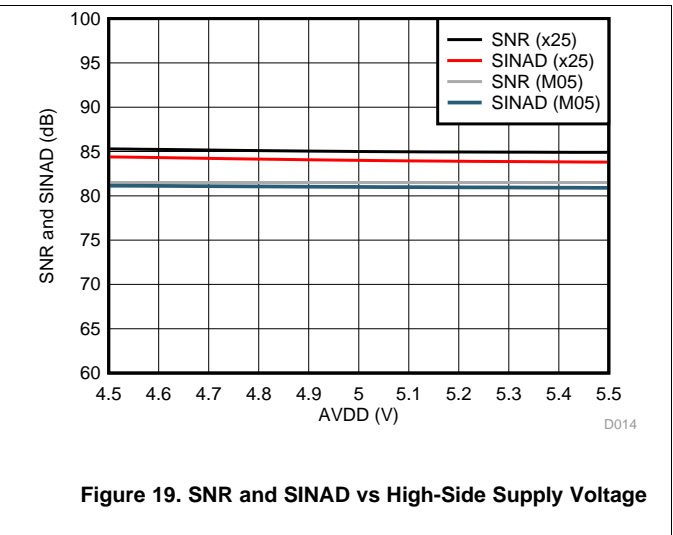

**Figure 19. SNR and SINAD vs High-Side Supply Voltage**

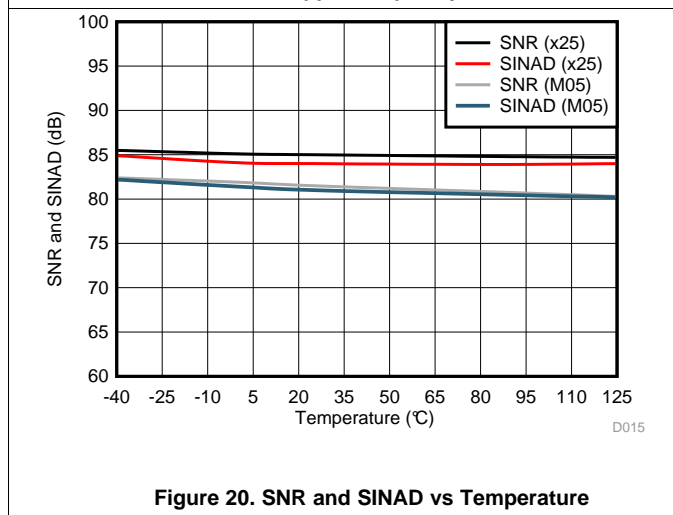

**Figure 20. SNR and SINAD vs Temperature**

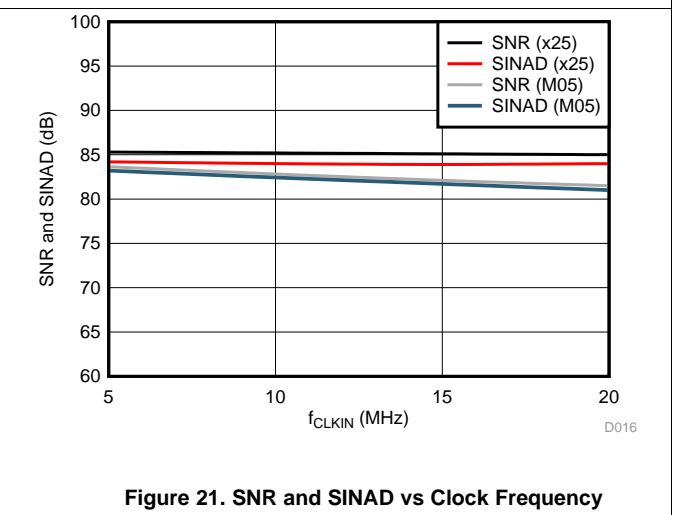

**Figure 21. SNR and SINAD vs Clock Frequency**

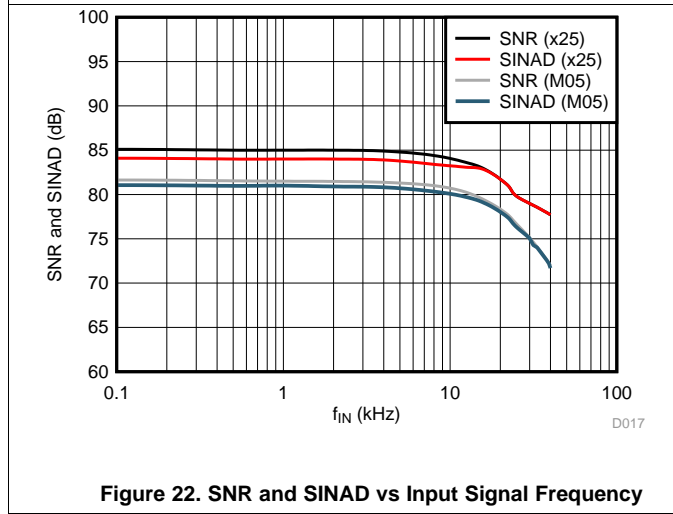

**Figure 22. SNR and SINAD vs Input Signal Frequency**

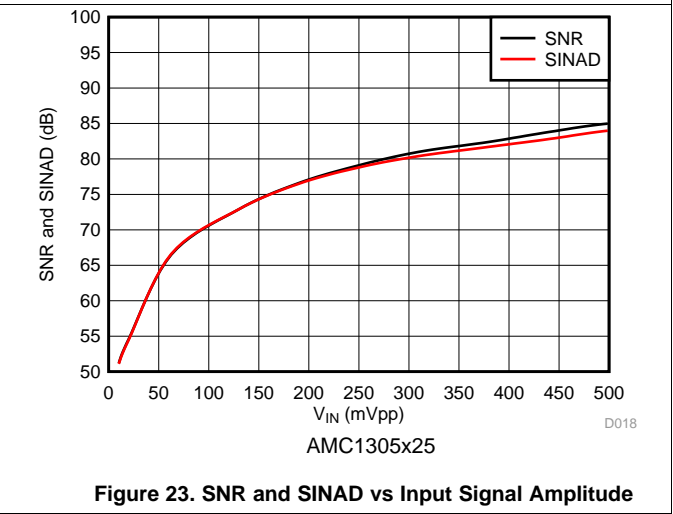

**Figure 23. SNR and SINAD vs Input Signal Amplitude**

Typical Characteristics (continued)

At  $T_A = 25^\circ\text{C}$ ,  $AVDD = 5.0\text{ V}$ ,  $DVDD = 3.3\text{ V}$ ,  $A\text{INP} = -250\text{ mV to }250\text{ mV}$ ,  $A\text{INN} = 0\text{ V}$ ,  $f_{\text{CLKIN}} = 20\text{ MHz}$ , and sinc<sup>3</sup> filter with OSR = 256, unless otherwise noted.

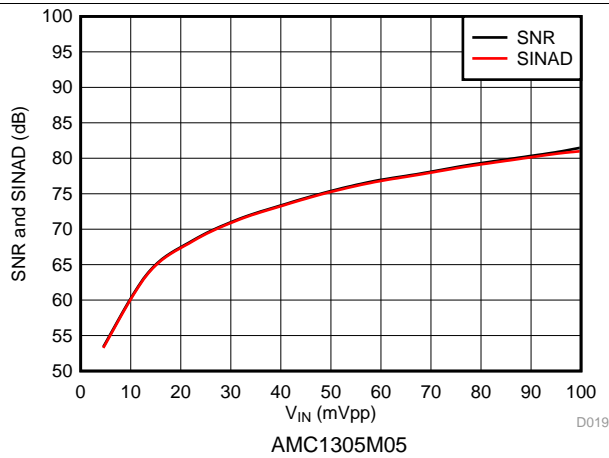

Figure 24. SNR and SINAD vs Input Signal Amplitude

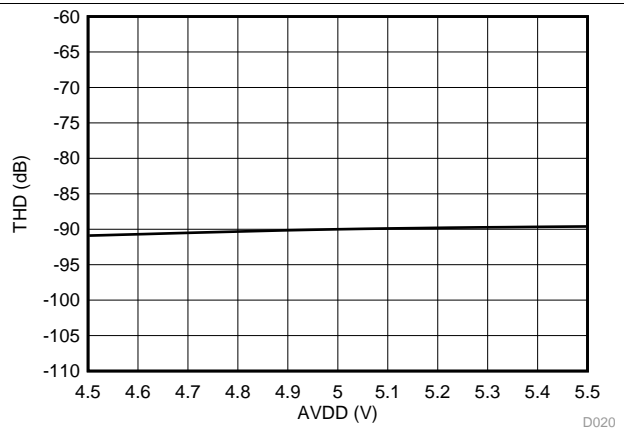

Figure 25. Total Harmonic Distortion vs High-Side Supply Voltage

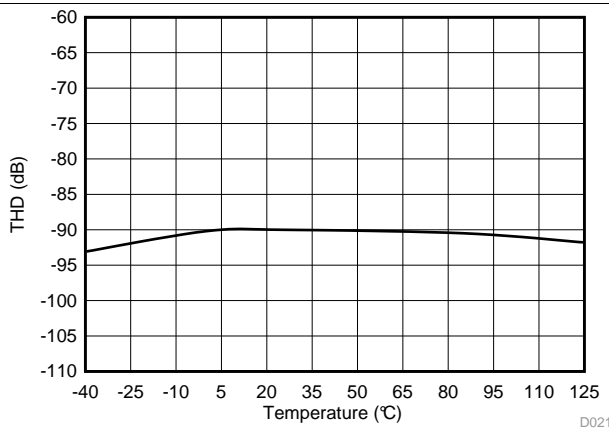

Figure 26. Total Harmonic Distortion vs Temperature

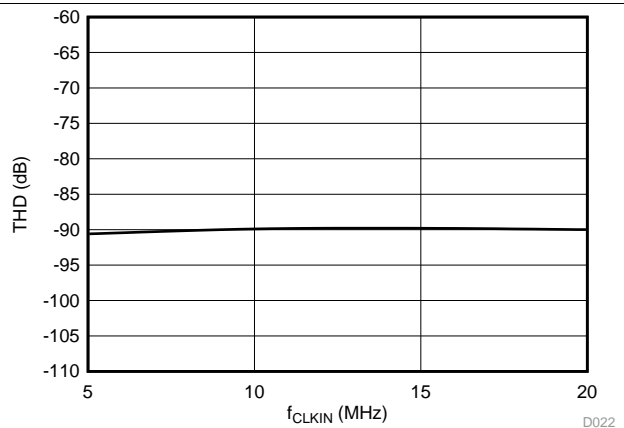

Figure 27. Total Harmonic Distortion vs Clock Frequency

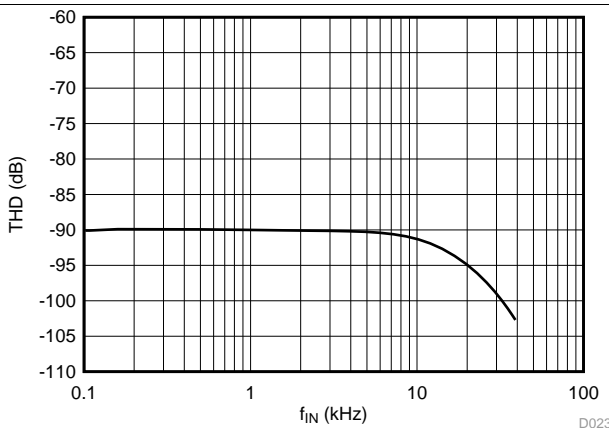

Figure 28. Total Harmonic Distortion vs Input Signal Frequency

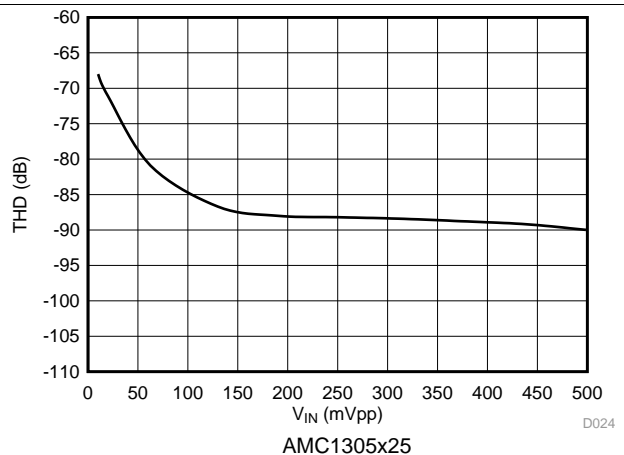

Figure 29. Total Harmonic Distortion vs Input Signal Amplitude

Typical Characteristics (continued)

At  $T_A = 25^\circ\text{C}$ ,  $AV_{DD} = 5.0\text{ V}$ ,  $DV_{DD} = 3.3\text{ V}$ ,  $A_{INP} = -250\text{ mV to }250\text{ mV}$ ,  $A_{INN} = 0\text{ V}$ ,  $f_{CLKIN} = 20\text{ MHz}$ , and sinc<sup>3</sup> filter with OSR = 256, unless otherwise noted.

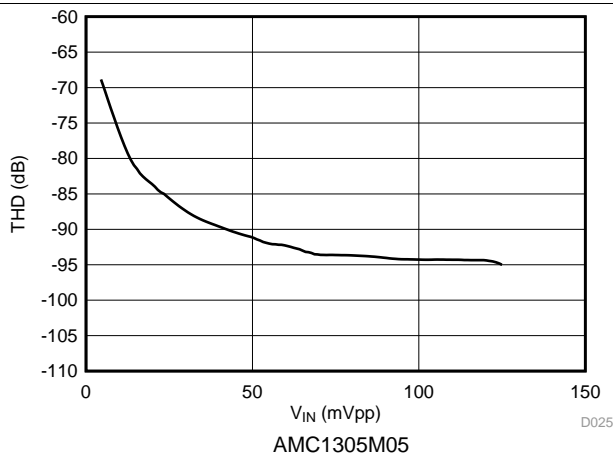

Figure 30. Total Harmonic Distortion vs Input Signal Amplitude

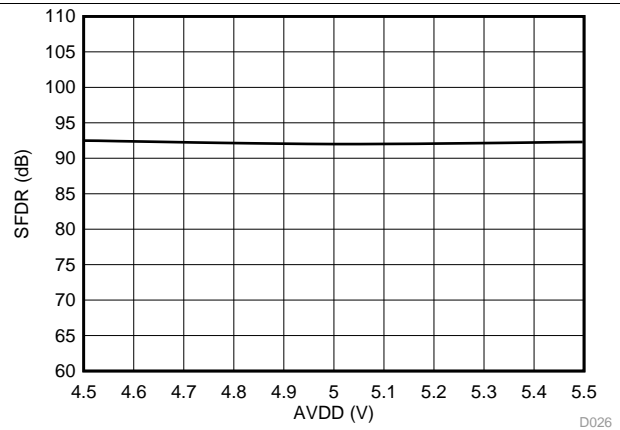

Figure 31. Spurious-Free Dynamic Range vs High-Side Supply Voltage

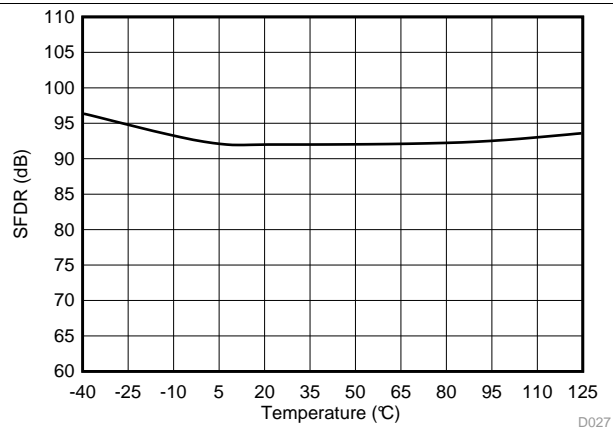

Figure 32. Spurious-Free Dynamic Range vs Temperature

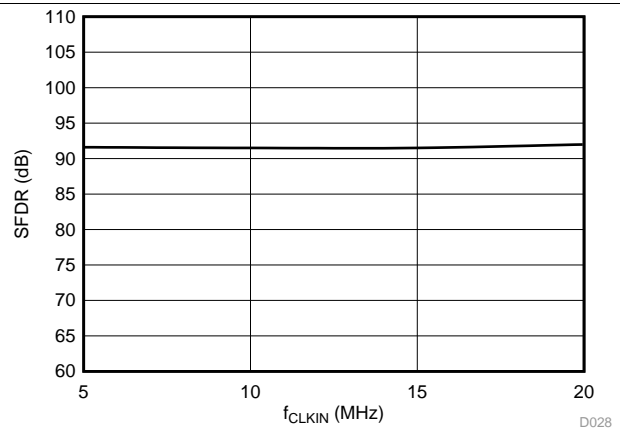

Figure 33. Spurious-Free Dynamic Range vs Clock Frequency

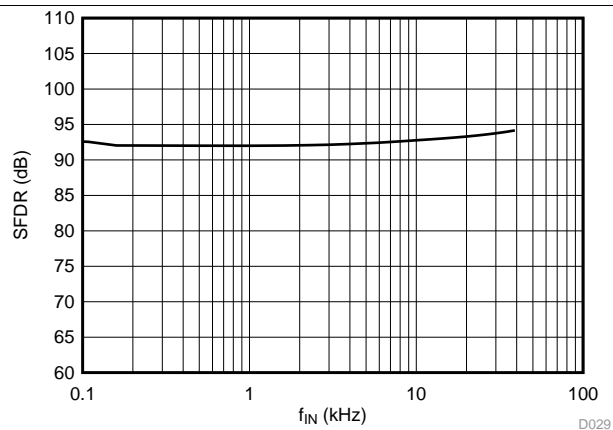

Figure 34. Spurious-Free Dynamic Range vs Input Signal Frequency

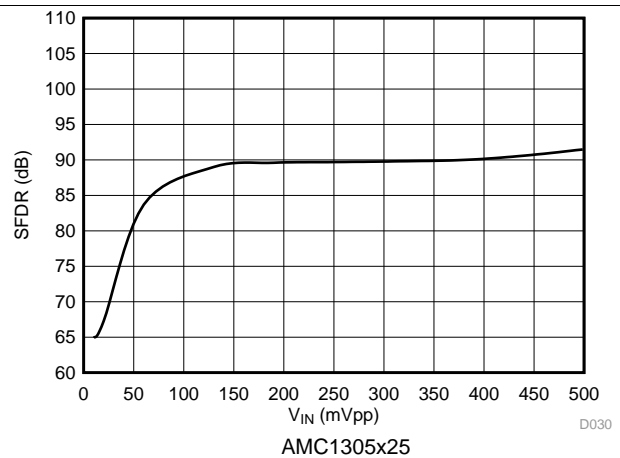

Figure 35. Spurious-Free Dynamic Range vs Input Signal Amplitude

### Typical Characteristics (continued)

At  $T_A = 25^\circ\text{C}$ ,  $AV_{DD} = 5.0\text{ V}$ ,  $DV_{DD} = 3.3\text{ V}$ ,  $A_{INP} = -250\text{ mV to }250\text{ mV}$ ,  $A_{INN} = 0\text{ V}$ ,  $f_{CLKIN} = 20\text{ MHz}$ , and sinc<sup>3</sup> filter with OSR = 256, unless otherwise noted.

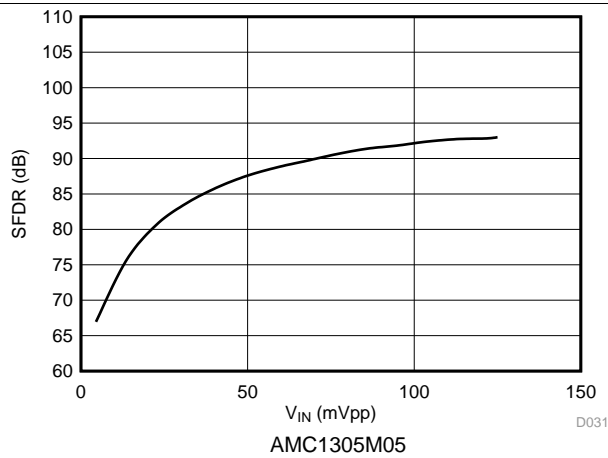

Figure 36. Spurious-Free Dynamic Range vs Input Signal Amplitude

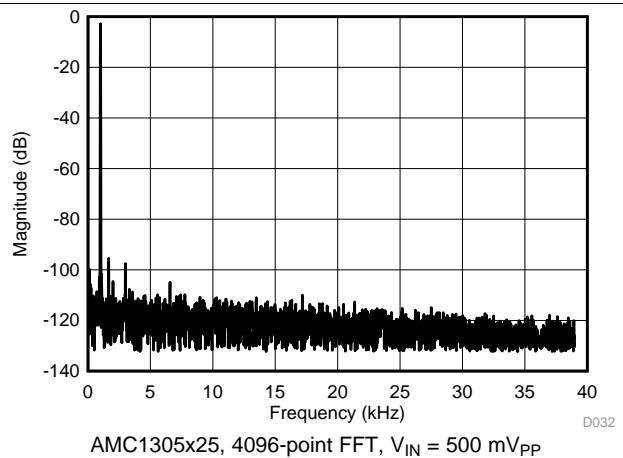

Figure 37. Frequency Spectrum with 1-kHz Input Signal

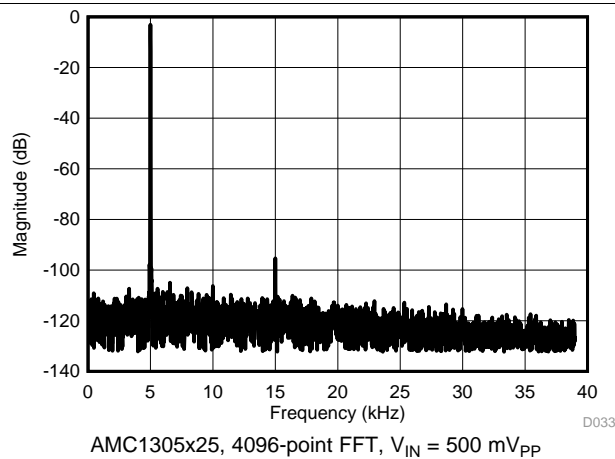

Figure 38. Frequency Spectrum with 5-kHz Input Signal

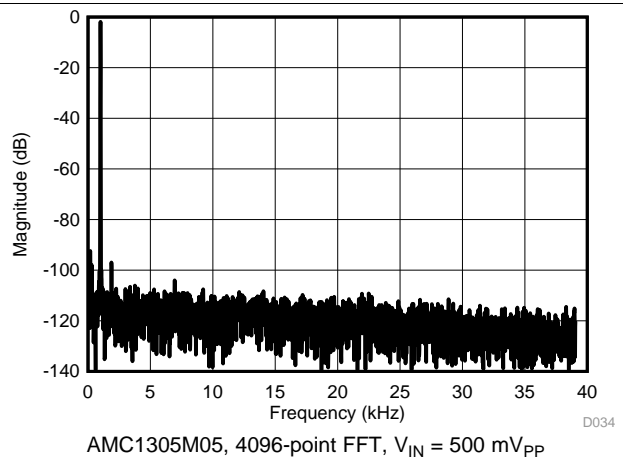

Figure 39. Frequency Spectrum with 1-kHz Input Signal

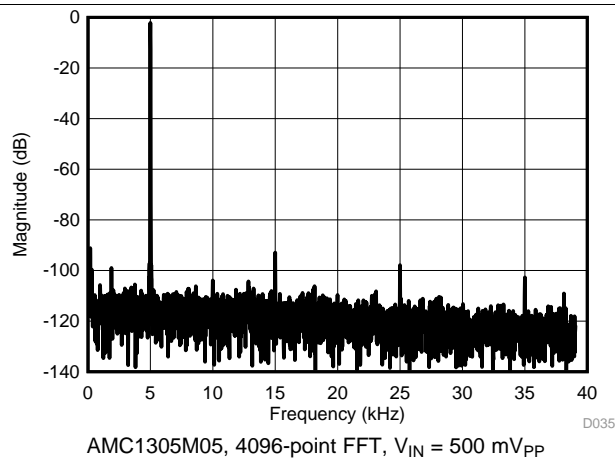

Figure 40. Frequency Spectrum with 5-kHz Input Signal

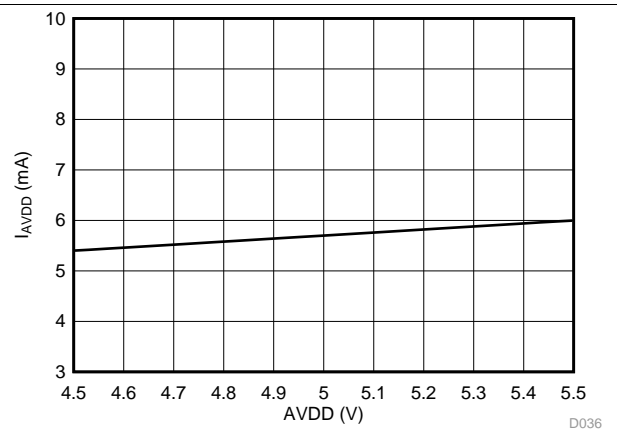

Figure 41. High-Side Supply Current vs High-Side Supply Voltage

### Typical Characteristics (continued)

At  $T_A = 25^\circ\text{C}$ ,  $AVDD = 5.0\text{ V}$ ,  $DVDD = 3.3\text{ V}$ ,  $A\text{INP} = -250\text{ mV to }250\text{ mV}$ ,  $A\text{INN} = 0\text{ V}$ ,  $f_{\text{CLKIN}} = 20\text{ MHz}$ , and sinc<sup>3</sup> filter with OSR = 256, unless otherwise noted.

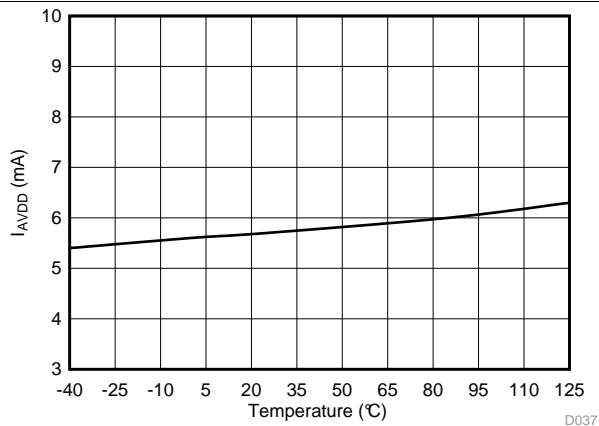

Figure 42. High-Side Supply Current vs Temperature

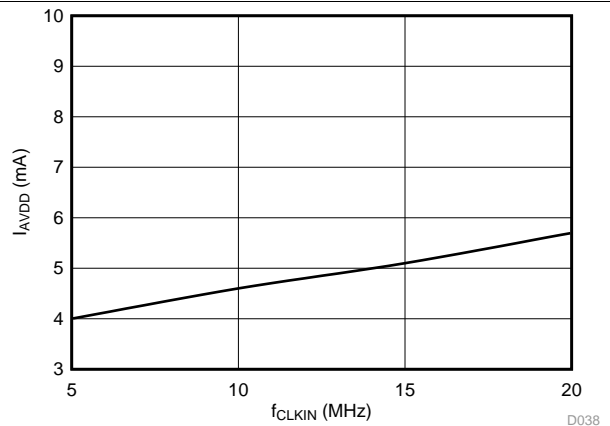

Figure 43. High-Side Supply Current vs Clock Frequency

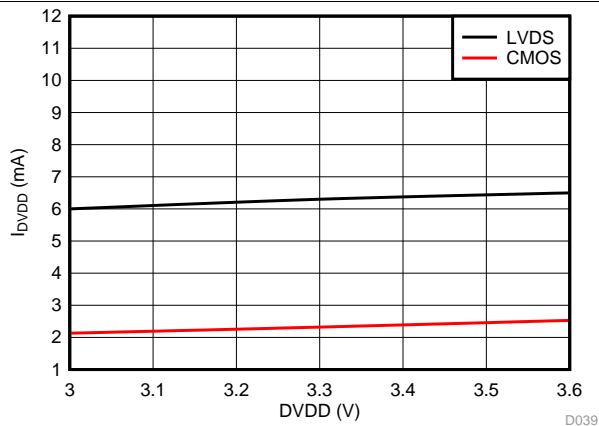

Figure 44. Controller-Side Supply Current vs Controller-Side Supply Voltage (3.3 V, nom)

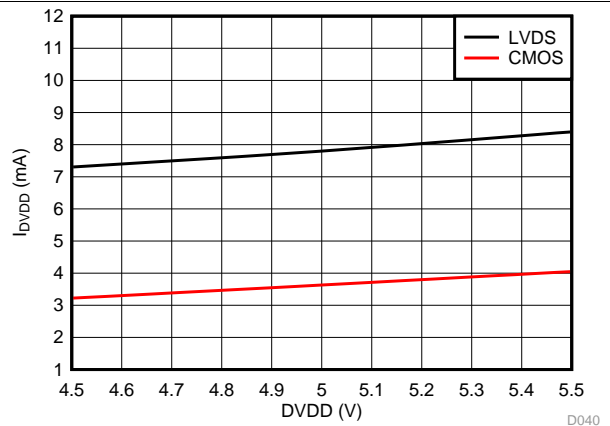

Figure 45. Controller-Side Supply Current vs Controller-Side Supply Voltage (5 V, nom)

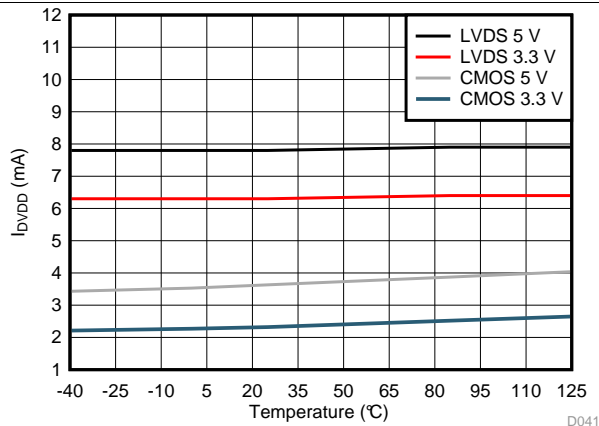

Figure 46. Controller-Side Supply Current vs Temperature

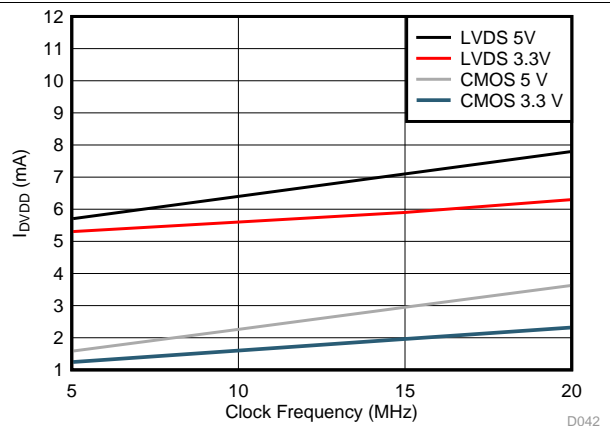

Figure 47. Controller-Side Supply Current vs Clock Frequency

## 8 Detailed Description

### 8.1 Overview

The differential analog input (AINP and AINN) of the AMC1305 is a fully-differential amplifier feeding the switched-capacitor input of a second-order delta-sigma ( $\Delta\Sigma$ ) modulator stage that digitizes the input signal into a 1-bit output stream. The isolated data output (DOUT) of the converter provides a stream of digital ones and zeros synchronous to the externally-provided clock source at the CLKIN pin with a frequency in the range of 5 MHz to 20.1 MHz. The time average of this serial bit-stream output is proportional to the analog input voltage.

The [Functional Block Diagram](#) section shows a detailed block diagram of the AMC1305. The analog input range is tailored to directly accommodate a voltage drop across a shunt resistor used for current sensing. The SiO<sub>2</sub>-based capacitive isolation barrier supports a high level of magnetic field immunity as described in the application report [ISO72x Digital Isolator Magnetic-Field Immunity](#) (SLLA181A), available for download at [www.ti.com](http://www.ti.com). The external clock input simplifies the synchronization of multiple current-sense channels on the system level. The extended frequency range of up to 20.1 MHz supports higher performance levels compared to other solutions available on the market.

### 8.2 Functional Block Diagram

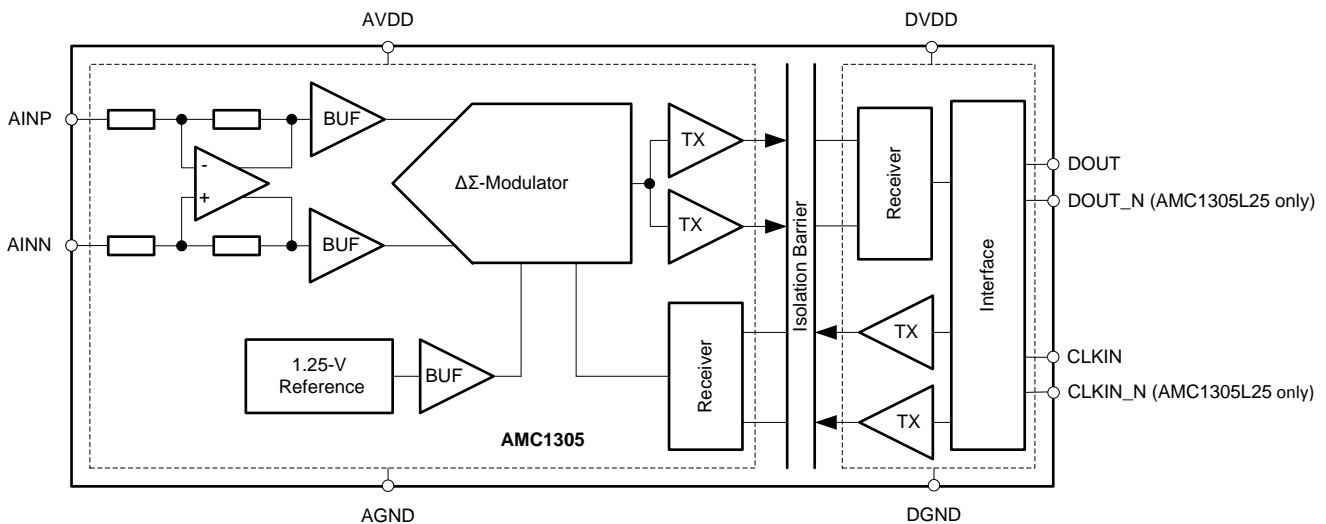

## 8.3 Feature Description

### 8.3.1 Analog Input

The AMC1305 incorporates front-end circuitry that contains a differential amplifier and sampling stage, followed by a  $\Delta\Sigma$  modulator. The gain of the differential amplifier is set by internal precision resistors to a factor of 4 for devices with a specified input voltage range of  $\pm 250$  mV (for the AMC1305x25), or to a factor of 20 for devices with a  $\pm 50$ -mV input voltage range (for the AMC1305M05), resulting in a differential input impedance of 5 k $\Omega$  (for the AMC1305M05) or 25 k $\Omega$  (for the AMC1305x25).

Consider the input impedance of the AMC1305 in designs with high-impedance signal sources that can cause degradation of gain and offset specifications. The importance of this effect, however, depends on the desired system performance. Additionally, the input bias current caused by the internal common-mode voltage at the output of the differential amplifier causes an offset that depends on the actual amplitude of the input signal. See the [Isolated Voltage Sensing](#) section for more details on reducing these effects.

There are two restrictions on the analog input signals (AINP and AINN). First, if the input voltage exceeds the range of AGND – 6 V to AVDD + 0.5 V, the input current must be limited to 10 mA because the device input electrostatic discharge (ESD) protection diodes turn on. In addition, the linearity and noise performance of the device are ensured only when the differential analog input voltage remains within the specified linear full-scale range (FSR), that is  $\pm 250$  mV (for the AMC1305x25) or  $\pm 50$  mV (for the AMC1305M05), and within the specified input common-mode range.

### 8.3.2 Modulator

The modulator implemented in the AMC1305 is a second-order, switched-capacitor, feed-forward  $\Delta\Sigma$  modulator, such as the one conceptualized in [Figure 48](#). The analog input voltage  $V_{IN}$  and the output  $V_5$  of the 1-bit digital-to-analog converter (DAC) are differentiated, providing an analog voltage  $V_1$  at the input of the first integrator stage. The output of the first integrator feeds the input of the second integrator stage, resulting in output voltage  $V_3$  that is differentiated with the input signal  $V_{IN}$  and the output of the first integrator  $V_2$ . Depending on the polarity of the resulting voltage  $V_4$ , the output of the comparator is changed. In this case, the 1-bit DAC responds on the next clock pulse by changing its analog output voltage  $V_5$ , causing the integrators to progress in the opposite direction while forcing the value of the integrator output to track the average value of the input.

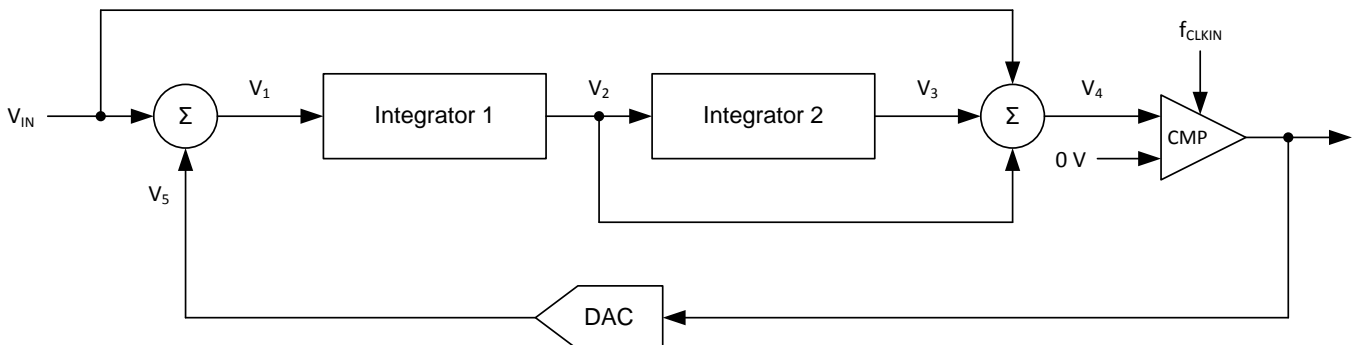

**Figure 48. Block Diagram of a Second-Order Modulator**

The modulator shifts the quantization noise to high frequencies; see [Figure 49](#). Therefore, use a low-pass digital filter at the output of the device to increase overall performance. This filter is also used to convert from the 1-bit data stream at a high sampling rate into a higher-bit data word at a lower rate (decimation). TI's microcontroller family [TMS320F2837x](#) offers a suitable programmable, hardwired filter structure termed a *sigma-delta filter module* (SDFM) optimized for usage with the AMC1305 family. Also, SD24\_B converters on the [MSP430F677x](#) microcontrollers offer a path to directly access the integrated sinc-filters, thus offering a system-level solution for multichannel isolated current sensing. An additional option is to use a suitable application-specific device (such as the [AMC1210](#), a four-channel digital sinc-filter). Alternatively, a field-programmable gate array (FPGA) can be used to implement the digital filter.

## Feature Description (continued)

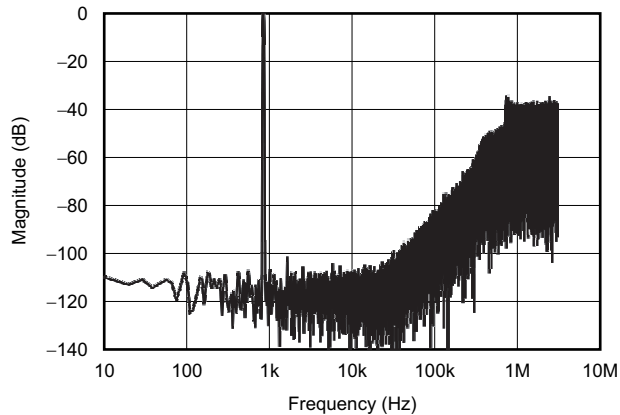

Figure 49. Quantization Noise Shaping

### 8.3.3 Digital Output

A differential input signal of 0 V ideally produces a stream of ones and zeros that are high 50% of the time. A differential input of 250 mV (for the AMC1305x25) or 50 mV (for the AMC1305M05) produces a stream of ones and zeros that are high 90% of the time. A differential input of –250 mV (–50 mV for the AMC1305M05) produces a stream of ones and zeros that are high 10% of the time. These input voltages are also the specified linear ranges of the different AMC1305 versions with performance as specified in this document. If the input voltage value exceeds these ranges, the output of the modulator shows non-linear behavior while the quantization noise increases. The output of the modulator would clip with a stream of only zeros with an input less than or equal to –312.5 mV (–62.5 mV for the AMC1305M05) or with a stream of only ones with an input greater than or equal to 312.5 mV (62.5 mV for the AMC1305M05). In this case, however, the AMC1305 generates a single 1 (if the input is at negative full-scale) or 0 every 128 clock cycles to indicate proper device function (see the [Fail-Safe Output](#) section for more details). The input voltage versus the output modulator signal is shown in [Figure 50](#).

The density of ones in the output bit-stream for any input voltage value (with the exception of a full-scale input signal as described in [Output Behavior in Case of Full-Scale Input](#)) can be calculated using [Equation 1](#):

$$\frac{V_{IN} + V_{Clipping}}{2 * V_{Clipping}} \quad (1)$$

The AMC1305 system clock is typically 20 MHz and is provided externally at the CLKIN pin. Data are synchronously provided at 20 MHz at the DOUT pin. Data change at the CLKIN falling edge. For more details, see the [Switching Characteristics](#) table.

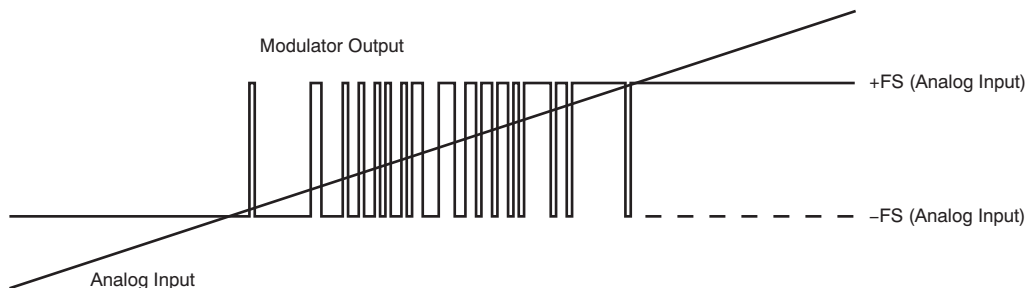

Figure 50. Analog Input versus AMC1305 Modulator Output

## 8.4 Device Functional Modes

### 8.4.1 Fail-Safe Output

In the case of a missing high-side supply voltage (AVDD), the output of a  $\Delta\Sigma$  modulator is not defined and could cause a system malfunction. In systems with high safety requirements, this behavior is not acceptable. Therefore, the AMC1305 implements a fail-safe output function that ensures the device maintains its output level in case of a missing AVDD, as shown in Figure 51.

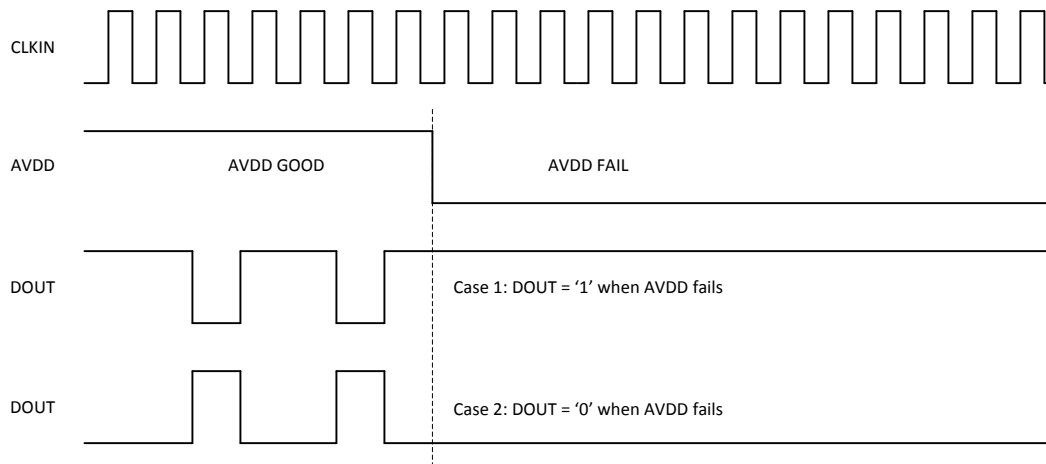

Figure 51. Fail-Safe Output of the AMC1305

### 8.4.2 Output Behavior in Case of Full-Scale Input

If a full-scale input signal is applied to the AMC1305 (that is,  $V_{IN} \geq V_{Clipping}$ ), the device generates a single one or zero every 128 bits at DOUT, depending on the actual polarity of the signal being sensed, as shown in Figure 52. In this way, differentiating between a missing AVDD and a full-scale input signal is possible on the system level.

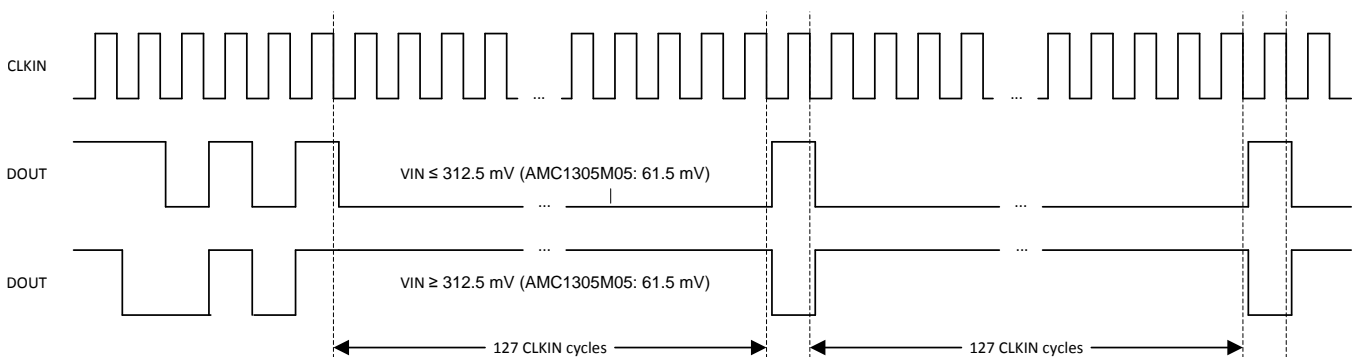

Figure 52. Overrange Output of the AMC1305

## 9 Application and Implementation

### NOTE

Information in the following applications sections is not part of the TI component specification, and TI does not warrant its accuracy or completeness. TI's customers are responsible for determining suitability of components for their purposes. Customers should validate and test their design implementation to confirm system functionality.

### 9.1 Application Information

#### 9.1.1 Digital Filter Usage

The modulator generates a bit stream that is processed by a digital filter to obtain a digital word similar to a conversion result of a conventional analog-to-digital converter (ADC). A very simple filter, built with minimal effort and hardware, is a sinc<sup>3</sup>-type filter, as shown in Equation 2:

$$H(z) = \left( \frac{1 - z^{-OSR}}{1 - z^{-1}} \right)^3 \quad (2)$$

This filter provides the best output performance at the lowest hardware size (count of digital gates) for a second-order modulator. All the characterization in this document is also done with a sinc<sup>3</sup> filter with an over-sampling ratio (OSR) of 256 and an output word width of 16 bits.

$$SNR = 1.76dB + 6.02dB * ENOB \quad (3)$$

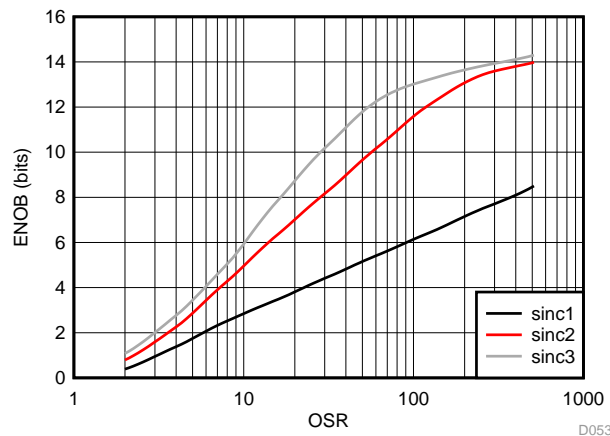

Figure 53. Measured Effective Number of Bits versus Oversampling Ratio

An example code for an implementation of a sinc<sup>3</sup> filter in an FPGA, see the application note [Combining ADS1202 with FPGA Digital Filter for Current Measurement in Motor Control Applications \(SBAA094\)](#), available for download at [www.ti.com](http://www.ti.com).

## 9.2 Typical Applications

### 9.2.1 Frequency Inverter Application

Because to their high ac and dc performance, isolated  $\Delta\Sigma$  modulators are being widely used in new generation frequency inverter designs. Frequency inverters are critical parts of industrial motor drives, photovoltaic inverters (string and central inverters), uninterruptible power supplies (UPS), electrical and hybrid electrical vehicles, and other industrial applications. The input structure of the AMC1305 is optimized for use with low-impedance shunt resistors and is therefore tailored for isolated current sensing using shunts.

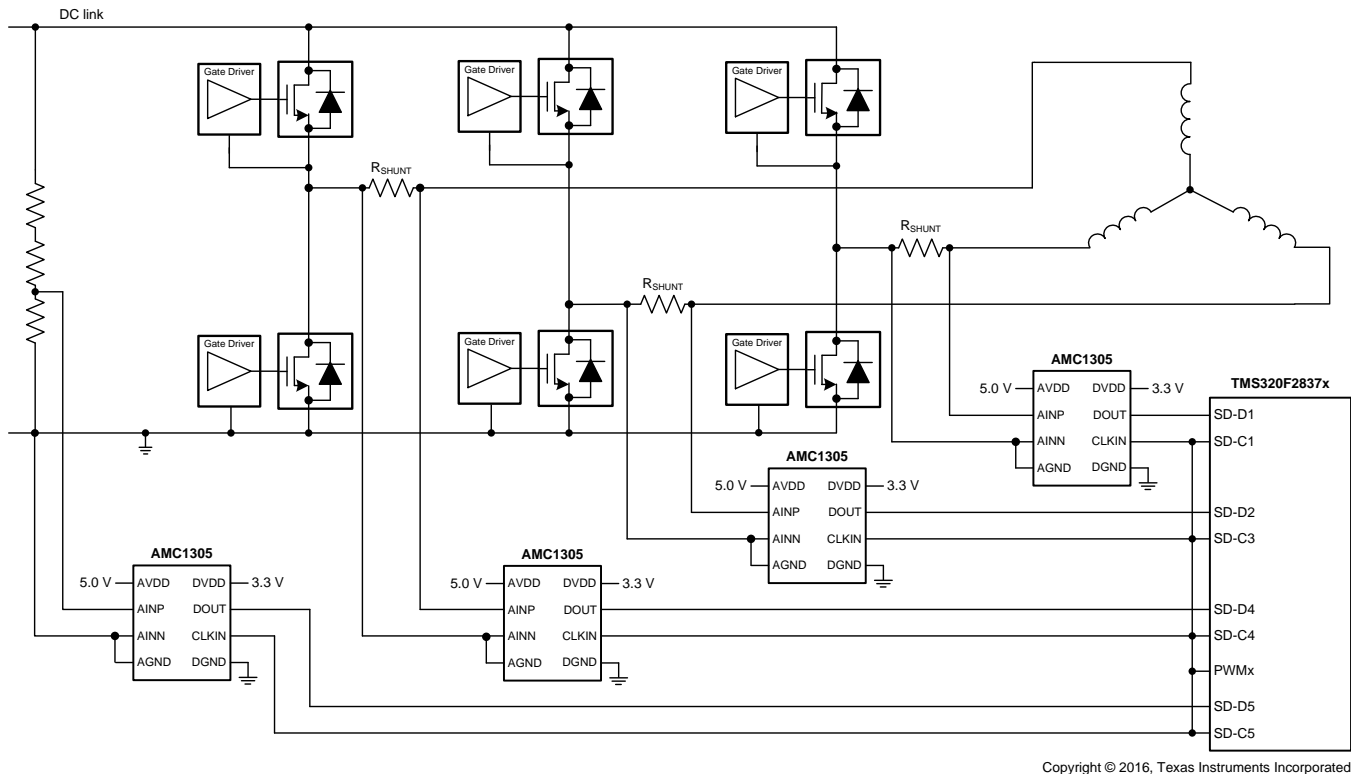

Copyright © 2016, Texas Instruments Incorporated

Figure 54. The AMC1305 in a Frequency Inverter Application

#### 9.2.1.1 Design Requirements

A typical operation of the device in a frequency inverter application is shown in Figure 54. When the inverter stage is part of a motor drive system, measurement of the motor phase current is done via the shunt resistors ( $R_{SHUNT}$ ). Depending on the system design, either all three or only two phase currents are sensed.

In this example, an additional fourth AMC1305 is used to support isolated voltage sensing of the dc link. This high voltage is reduced using a high-impedance resistive divider before being sensed by the device across a smaller resistor. The value of this resistor can degrade the performance of the measurement, as described in the [Isolated Voltage Sensing](#) section.

#### 9.2.1.2 Detailed Design Procedure

The usually recommended RC filter in front of a  $\Delta\Sigma$  modulator to improve signal-to-noise performance of the signal path, is not required for the AMC1305. By design, the input bandwidth of the analog front-end of the device is limited to 1 MHz.

For modulator output bit-stream filtering, a device from TI's [TMS320F2837x](#) family of dual-core MCUs is recommended. This family supports up to eight channels of dedicated hardwired filter structures that significantly simplify system level design by offering two filtering paths per channel: one providing high accuracy results for the control loop and one fast response path for overcurrent detection.

## Typical Applications (continued)

### 9.2.1.3 Application Curve

In motor control applications, a very fast response time for overcurrent detection is required. The time for fully settling the filter in case of a step-signal at the input of the modulator depends on its order; that is, a sinc<sup>3</sup> filter requires three data updates for full settling (with  $f_{DATA} = f_{CLK} / OSR$ ). Therefore, for overcurrent protection, filter types other than sinc<sup>3</sup> can be a better choice; an alternative is the sinc<sup>2</sup> filter. Figure 55 compares the settling times of different filter orders.

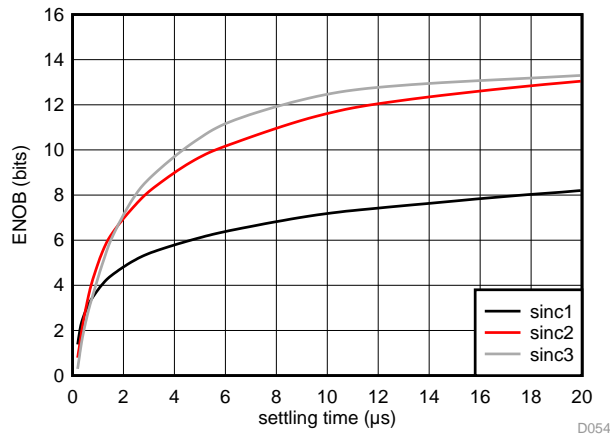

**Figure 55. Measured Effective Number of Bits versus Settling Time**

The delay time of the sinc filter with a continuous signal is half of its settling time.

## Typical Applications (continued)

### 9.2.2 Isolated Voltage Sensing

The AMC1305 is optimized for usage in current-sensing applications using low-impedance shunts. However, the device can also be used in isolated voltage-sensing applications if the impact of the (usually higher) impedance of the resistor used in this case is considered.

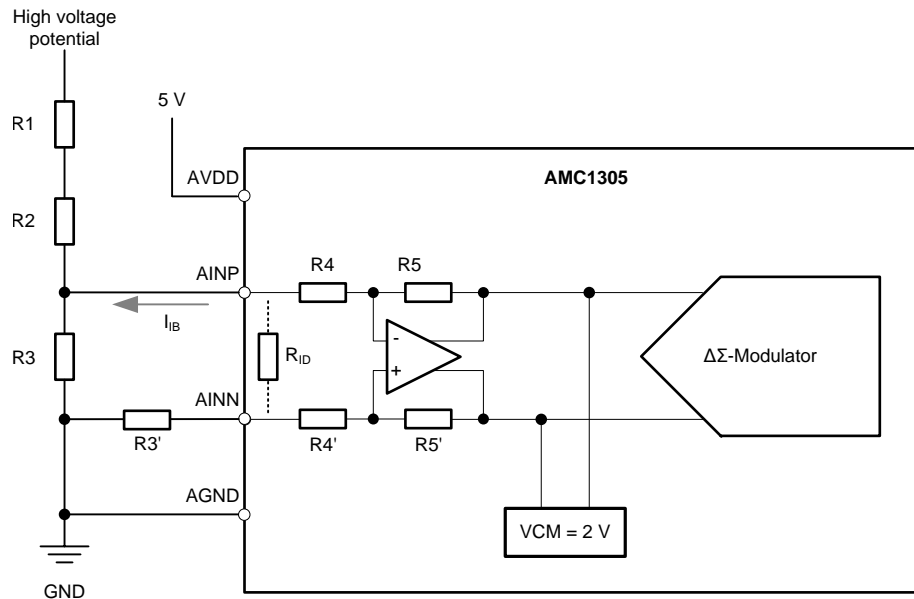

**Figure 56. Using AMC1305 for Isolated Voltage Sensing**

#### 9.2.2.1 Design Requirements

Figure 56 shows a simplified circuit typically used in high-voltage sensing applications. The high impedance resistors (R1 and R2) are used as voltage dividers and dominate the current value definition. The resistance of the sensing resistor R3 is chosen to meet the input voltage range of the AMC1305. This resistor and the differential input impedance of the device (the AMC1305x25 is 25 kΩ, the AMC1305M05 is 5 kΩ) also create a voltage divider that results in an additional gain error. With the assumption of R1, R2, and R<sub>IN</sub> having a considerably higher value than R3, the resulting total gain error can be estimated using Equation 4, with E<sub>G</sub> being the gain error of the AMC1305.

$$|E_{Tot}| = |E_G| + \frac{R_3}{R_{IN}} \quad (4)$$

This gain error can be easily minimized during the initial system level gain calibration procedure.

#### 9.2.2.2 Detailed Design Procedure

As indicated in Figure 56, the output of the integrated differential amplifier is internally biased to a common-mode voltage of 2 V. This voltage results in a bias current I<sub>B</sub> through the resistive network R4 and R5 (or R4' and R5') used for setting the gain of the amplifier. The value range of this current is specified in the Electrical Characteristics table. This bias current generates additional offset error that depends on the value of the resistor R3. Because the value of this bias current depends on the actual common-mode amplitude of the input signal (as shown in Figure 57), the initial system offset calibration does not minimize its effect. Therefore, in systems with high accuracy requirements TI recommends using a series resistor at the negative input (AINN) of the AMC1305 with a value equal to the shunt resistor R3 (that is R3' = R3 in Figure 56) to eliminate the effect of the bias current.

**Typical Applications (continued)**

This additional series resistor (R3') influences the gain error of the circuit. The effect can be calculated using Equation 5 with R5 = R5' = 50 kΩ and R4 = R4' = 2.5 kΩ (for the AMC1305M05) or 12.5 kΩ (for the AMC1305x25).

$$E_G(\%) = \left( 1 - \frac{R4}{R4'+R3'} \right) * 100\% \tag{5}$$

**9.2.2.3 Application Curve**

Figure 57 shows the dependency of the input bias current on the common-mode voltage at the input of the AMC1305.

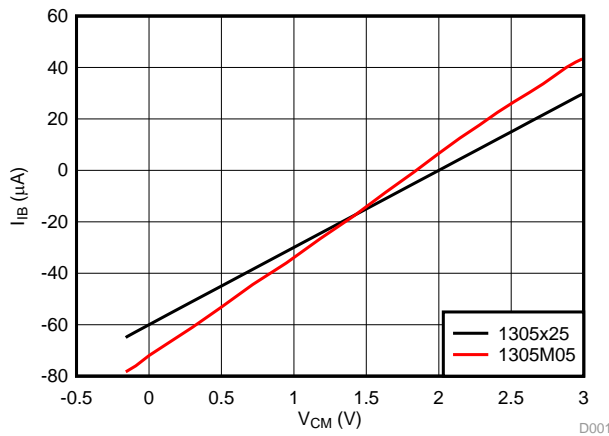
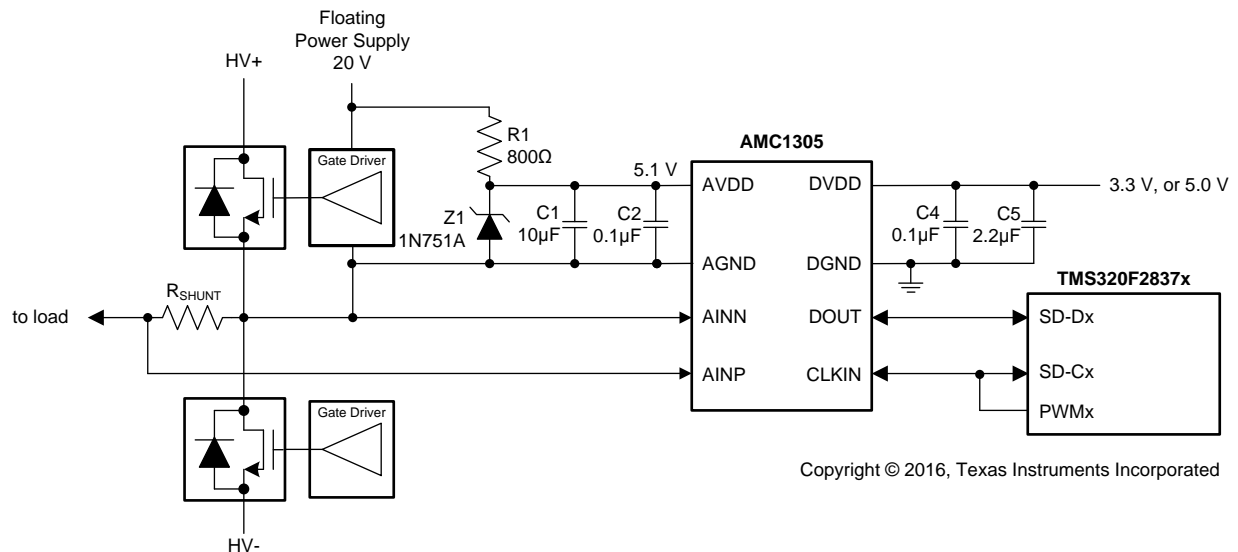

**Figure 57. Input Current vs Input Common-Mode Voltage**

## 10 Power-Supply Recommendations

In a typical frequency inverter application, the high-side power supply (AVDD) for the device is derived from the floating power supply of the upper gate driver. For lowest cost, a Zener diode can be used to limit the voltage to  $5\text{ V} \pm 10\%$ . Alternatively a low-cost low-drop regulator (LDO), for example the [LM317-N](#), can be used to minimize noise on the power supply. A low-ESR decoupling capacitor of  $0.1\ \mu\text{F}$  is recommended for filtering this power-supply path. Place this capacitor ( $C_2$  in [Figure 58](#)) as close as possible to the AVDD pin of the AMC1305 for best performance. If better filtering is required, an additional  $10\text{-}\mu\text{F}$  capacitor can be used. The floating ground reference (AGND) is derived from the end of the shunt resistor, which is connected to the negative input (AINN) of the device. If a four-pin shunt is used, the device inputs are connected to the inner leads, while AGND is connected to one of the outer leads of the shunt.

For decoupling of the digital power supply on controller side, TI recommends using a  $0.1\text{-}\mu\text{F}$  capacitor assembled as close to the DVDD pin of the AMC1305 as possible, followed by an additional capacitor in the range of  $1\ \mu\text{F}$  to  $10\ \mu\text{F}$ .



Copyright © 2016, Texas Instruments Incorporated

Figure 58. Zener-Diode-Based High-Side Power Supply

## 11 Layout

### 11.1 Layout Guidelines

A layout recommendation showing the critical placement of the decoupling capacitors (as close as possible to the AMC1305) and placement of the other components required by the device is shown in Figure 59.

For the AMC1305L25 version, place the 100-Ω termination resistor as close as possible to the CLKIN, CLKIN\_N inputs of the device to achieve highest signal integrity. If not integrated, an additional termination resistor is required as close as possible to the LVDS data inputs of the MCU or filter device; see Figure 60.

### 11.2 Layout Examples

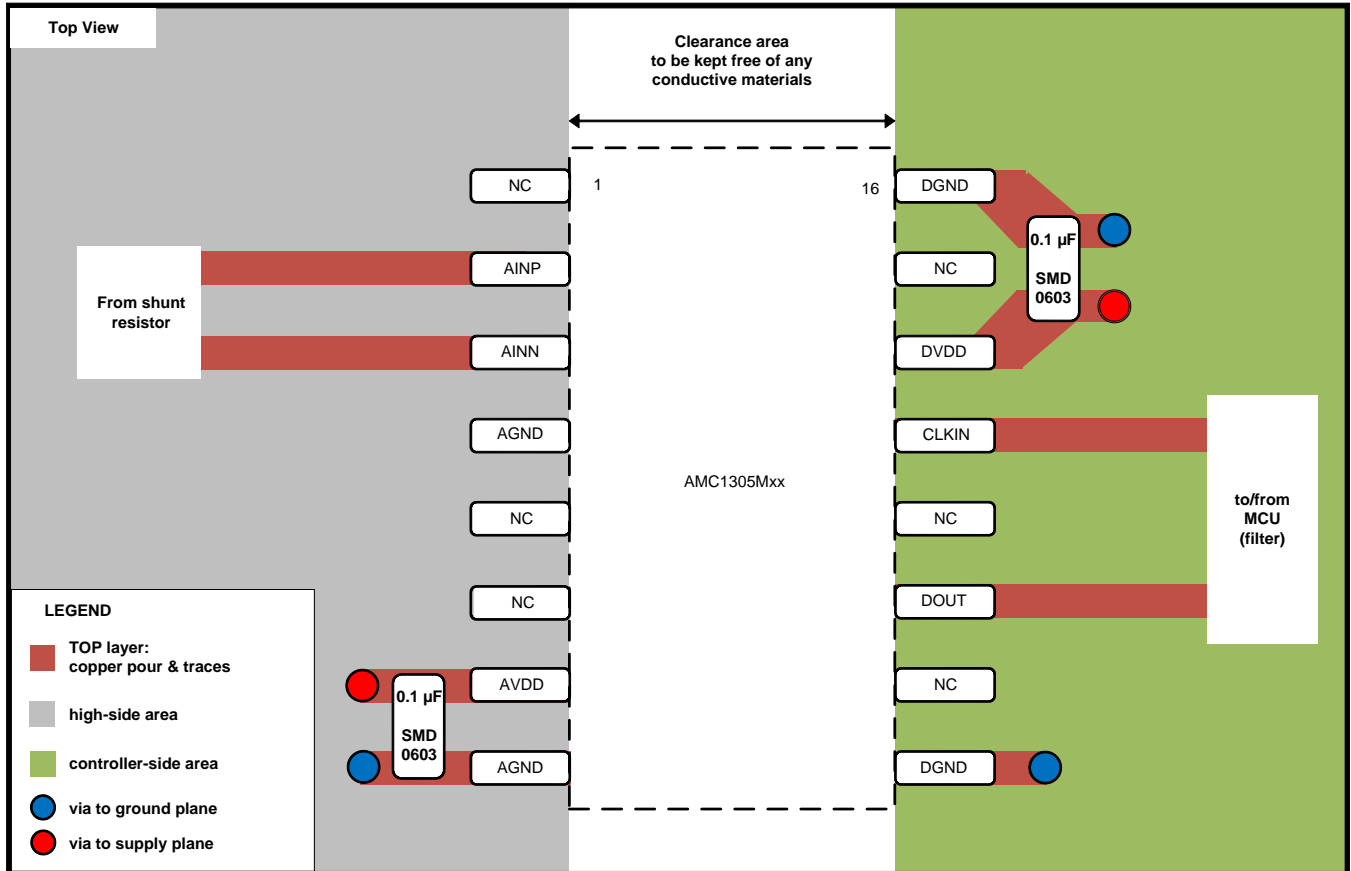

Figure 59. Recommended Layout of the AMC1305Mx

Layout Examples (continued)

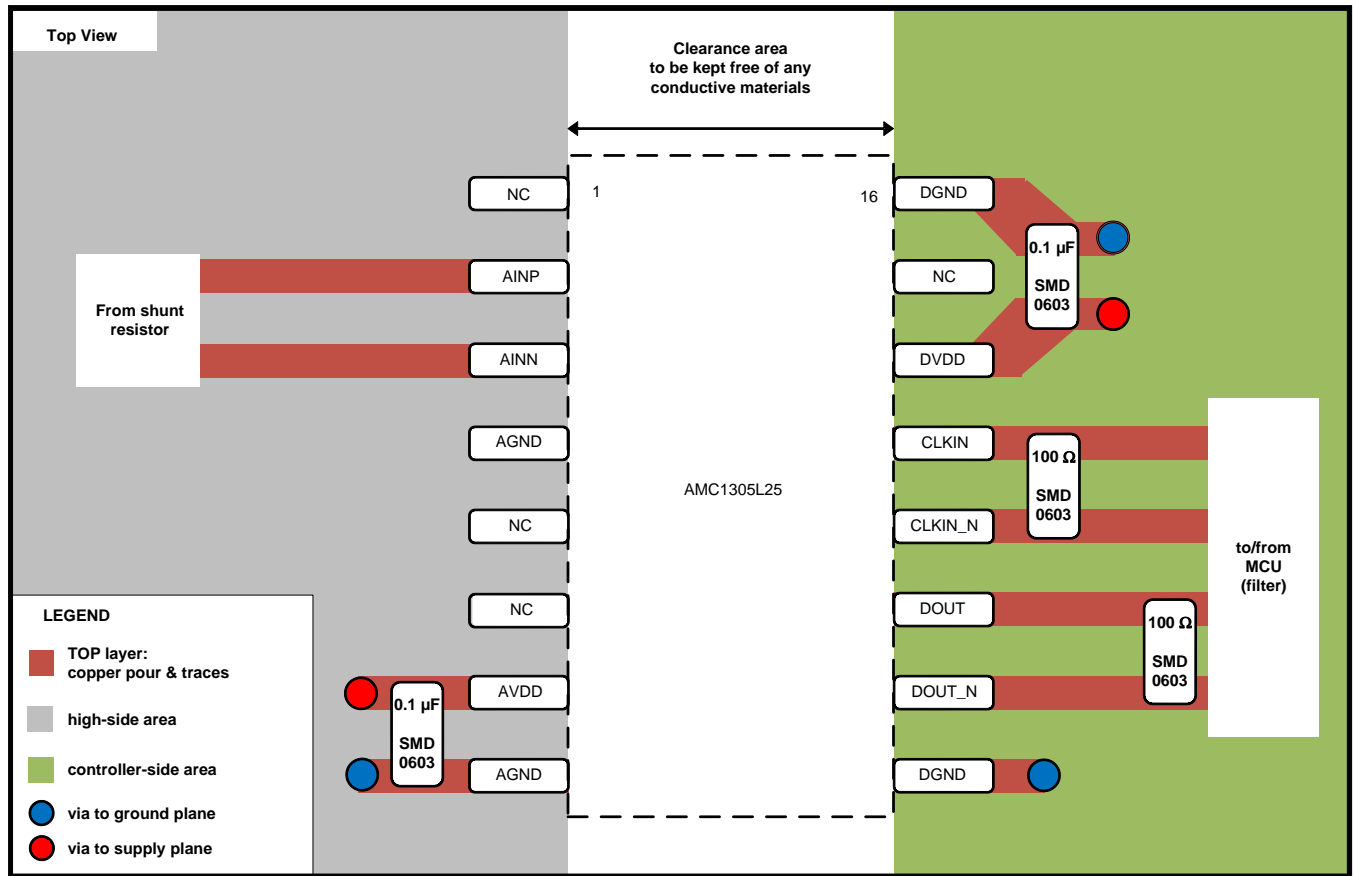

Figure 60. Recommended Layout of the AMC1305L25

## 12 Device and Documentation Support

### 12.1 Documentation Support

#### 12.1.1 Related Documentation

For related documentation see the following:

- [Isolation Glossary](#)
- [ISO72x Digital Isolator Magnetic-Field Immunity](#)
- [Combining ADS1202 with FPGA Digital Filter for Current Measurement in Motor Control Applications](#)
- [LM117, LM317-N Wide Temperature Three-Pin Adjustable Regulator](#)
- [TMS320F2837xD Dual-Core Delfino™ Microcontrollers](#)
- [MSP430F677x Polyphase Metering SoCs](#)
- [AMC1210 Quad Digital Filter for 2nd-Order Delta-Sigma Modulator](#)

#### 12.2 Related Links

The table below lists quick access links. Categories include technical documents, support and community resources, tools and software, and quick access to order now.

**Table 1. Related Links**

PARTS	PRODUCT FOLDER	ORDER NOW	TECHNICAL DOCUMENTS	TOOLS & SOFTWARE	SUPPORT & COMMUNITY
AMC1305L25	<a href="#">Click here</a>	<a href="#">Click here</a>	<a href="#">Click here</a>	<a href="#">Click here</a>	<a href="#">Click here</a>
AMC1305M05	<a href="#">Click here</a>	<a href="#">Click here</a>	<a href="#">Click here</a>	<a href="#">Click here</a>	<a href="#">Click here</a>
AMC1305M25	<a href="#">Click here</a>	<a href="#">Click here</a>	<a href="#">Click here</a>	<a href="#">Click here</a>	<a href="#">Click here</a>

#### 12.3 Receiving Notification of Documentation Updates

To receive notification of documentation updates, navigate to the device product folder on ti.com. In the upper right corner, click on *Alert me* to register and receive a weekly digest of any product information that has changed. For change details, review the revision history included in any revised document.

#### 12.4 Community Resource

The following links connect to TI community resources. Linked contents are provided "AS IS" by the respective contributors. They do not constitute TI specifications and do not necessarily reflect TI's views; see TI's [Terms of Use](#).

**TI E2E™ Online Community** *TI's Engineer-to-Engineer (E2E) Community*. Created to foster collaboration among engineers. At e2e.ti.com, you can ask questions, share knowledge, explore ideas and help solve problems with fellow engineers.

**Design Support** *TI's Design Support* Quickly find helpful E2E forums along with design support tools and contact information for technical support.

#### 12.5 Trademarks

E2E is a trademark of Texas Instruments.

All other trademarks are the property of their respective owners.

#### 12.6 Electrostatic Discharge Caution



This integrated circuit can be damaged by ESD. Texas Instruments recommends that all integrated circuits be handled with appropriate precautions. Failure to observe proper handling and installation procedures can cause damage.

ESD damage can range from subtle performance degradation to complete device failure. Precision integrated circuits may be more susceptible to damage because very small parametric changes could cause the device not to meet its published specifications.

## 12.7 Glossary

[SLYZ022](#) — *TI Glossary*.

This glossary lists and explains terms, acronyms, and definitions.

## 13 Mechanical, Packaging, and Orderable Information

The following pages include mechanical, packaging, and orderable information. This information is the most current data available for the designated devices. This data is subject to change without notice and revision of this document. For browser-based versions of this data sheet, refer to the left-hand navigation.

## PACKAGING INFORMATION

Orderable Device	Status (1)	Package Type	Package Drawing	Pins	Package Qty	Eco Plan (2)	Lead/Ball Finish (6)	MSL Peak Temp (3)	Op Temp (°C)	Device Marking (4/5)	Samples
AMC1305L25DW	ACTIVE	SOIC	DW	16	40	Green (RoHS & no Sb/Br)	CU NIPDAU	Level-3-260C-168 HR	-40 to 125	AMC1305L25	<a href="#">Samples</a>
AMC1305L25DWR	ACTIVE	SOIC	DW	16	2000	Green (RoHS & no Sb/Br)	CU NIPDAU	Level-3-260C-168 HR	-40 to 125	AMC1305L25	<a href="#">Samples</a>
AMC1305M05DW	ACTIVE	SOIC	DW	16	40	Green (RoHS & no Sb/Br)	CU NIPDAU	Level-3-260C-168 HR	-40 to 125	AMC1305M05	<a href="#">Samples</a>
AMC1305M05DWR	ACTIVE	SOIC	DW	16	2000	Green (RoHS & no Sb/Br)	CU NIPDAU	Level-3-260C-168 HR	-40 to 125	AMC1305M05	<a href="#">Samples</a>
AMC1305M25DW	ACTIVE	SOIC	DW	16	40	Green (RoHS & no Sb/Br)	CU NIPDAU	Level-3-260C-168 HR	-40 to 125	AMC1305M25	<a href="#">Samples</a>
AMC1305M25DWR	ACTIVE	SOIC	DW	16	2000	Green (RoHS & no Sb/Br)	CU NIPDAU	Level-3-260C-168 HR	-40 to 125	AMC1305M25	<a href="#">Samples</a>

(1) The marketing status values are defined as follows:

**ACTIVE:** Product device recommended for new designs.

**LIFEBUY:** TI has announced that the device will be discontinued, and a lifetime-buy period is in effect.

**NRND:** Not recommended for new designs. Device is in production to support existing customers, but TI does not recommend using this part in a new design.

**PREVIEW:** Device has been announced but is not in production. Samples may or may not be available.

**OBSOLETE:** TI has discontinued the production of the device.

(2) Eco Plan - The planned eco-friendly classification: Pb-Free (RoHS), Pb-Free (RoHS Exempt), or Green (RoHS & no Sb/Br) - please check <http://www.ti.com/productcontent> for the latest availability information and additional product content details.

**TBD:** The Pb-Free/Green conversion plan has not been defined.

**Pb-Free (RoHS):** TI's terms "Lead-Free" or "Pb-Free" mean semiconductor products that are compatible with the current RoHS requirements for all 6 substances, including the requirement that lead not exceed 0.1% by weight in homogeneous materials. Where designed to be soldered at high temperatures, TI Pb-Free products are suitable for use in specified lead-free processes.

**Pb-Free (RoHS Exempt):** This component has a RoHS exemption for either 1) lead-based flip-chip solder bumps used between the die and package, or 2) lead-based die adhesive used between the die and leadframe. The component is otherwise considered Pb-Free (RoHS compatible) as defined above.

**Green (RoHS & no Sb/Br):** TI defines "Green" to mean Pb-Free (RoHS compatible), and free of Bromine (Br) and Antimony (Sb) based flame retardants (Br or Sb do not exceed 0.1% by weight in homogeneous material)

(3) MSL, Peak Temp. - The Moisture Sensitivity Level rating according to the JEDEC industry standard classifications, and peak solder temperature.

(4) There may be additional marking, which relates to the logo, the lot trace code information, or the environmental category on the device.

(5) Multiple Device Markings will be inside parentheses. Only one Device Marking contained in parentheses and separated by a "~" will appear on a device. If a line is indented then it is a continuation of the previous line and the two combined represent the entire Device Marking for that device.

<sup>(6)</sup> Lead/Ball Finish - Orderable Devices may have multiple material finish options. Finish options are separated by a vertical ruled line. Lead/Ball Finish values may wrap to two lines if the finish value exceeds the maximum column width.

**Important Information and Disclaimer:**The information provided on this page represents TI's knowledge and belief as of the date that it is provided. TI bases its knowledge and belief on information provided by third parties, and makes no representation or warranty as to the accuracy of such information. Efforts are underway to better integrate information from third parties. TI has taken and continues to take reasonable steps to provide representative and accurate information but may not have conducted destructive testing or chemical analysis on incoming materials and chemicals. TI and TI suppliers consider certain information to be proprietary, and thus CAS numbers and other limited information may not be available for release.

In no event shall TI's liability arising out of such information exceed the total purchase price of the TI part(s) at issue in this document sold by TI to Customer on an annual basis.

**OTHER QUALIFIED VERSIONS OF AMC1305L25, AMC1305M05, AMC1305M25 :**

- Automotive: [AMC1305L25-Q1](#), [AMC1305M05-Q1](#), [AMC1305M25-Q1](#)

**NOTE: Qualified Version Definitions:**

- Automotive - Q100 devices qualified for high-reliability automotive applications targeting zero defects

## TAPE AND REEL INFORMATION



### QUADRANT ASSIGNMENTS FOR PIN 1 ORIENTATION IN TAPE



\*All dimensions are nominal

Device	Package Type	Package Drawing	Pins	SPQ	Reel Diameter (mm)	Reel Width W1 (mm)	A0 (mm)	B0 (mm)	K0 (mm)	P1 (mm)	W (mm)	Pin1 Quadrant
AMC1305L25DWR	SOIC	DW	16	2000	330.0	16.4	10.75	10.7	2.7	12.0	16.0	Q1
AMC1305M05DWR	SOIC	DW	16	2000	330.0	16.4	10.75	10.7	2.7	12.0	16.0	Q1
AMC1305M25DWR	SOIC	DW	16	2000	330.0	16.4	10.75	10.7	2.7	12.0	16.0	Q1

## TAPE AND REEL BOX DIMENSIONS

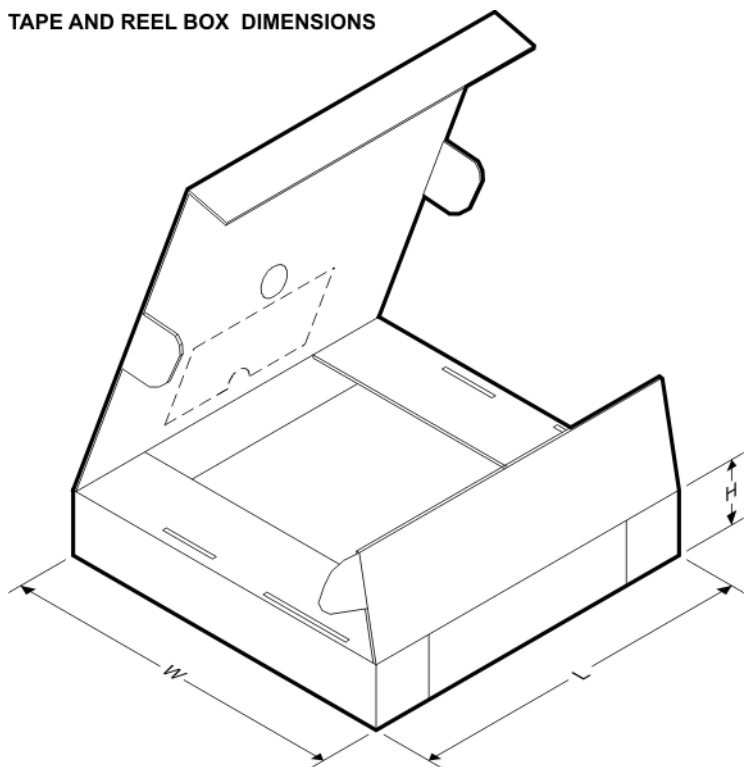

\*All dimensions are nominal

Device	Package Type	Package Drawing	Pins	SPQ	Length (mm)	Width (mm)	Height (mm)
AMC1305L25DWR	SOIC	DW	16	2000	350.0	350.0	43.0
AMC1305M05DWR	SOIC	DW	16	2000	350.0	350.0	43.0
AMC1305M25DWR	SOIC	DW	16	2000	350.0	350.0	43.0

## GENERIC PACKAGE VIEW

**DW 16**

**SOIC - 2.65 mm max height**

7.5 x 10.3, 1.27 mm pitch

SMALL OUTLINE INTEGRATED CIRCUIT

This image is a representation of the package family, actual package may vary.  
Refer to the product data sheet for package details.



4224780/A



# DW0016B

# PACKAGE OUTLINE

## SOIC - 2.65 mm max height

SOIC

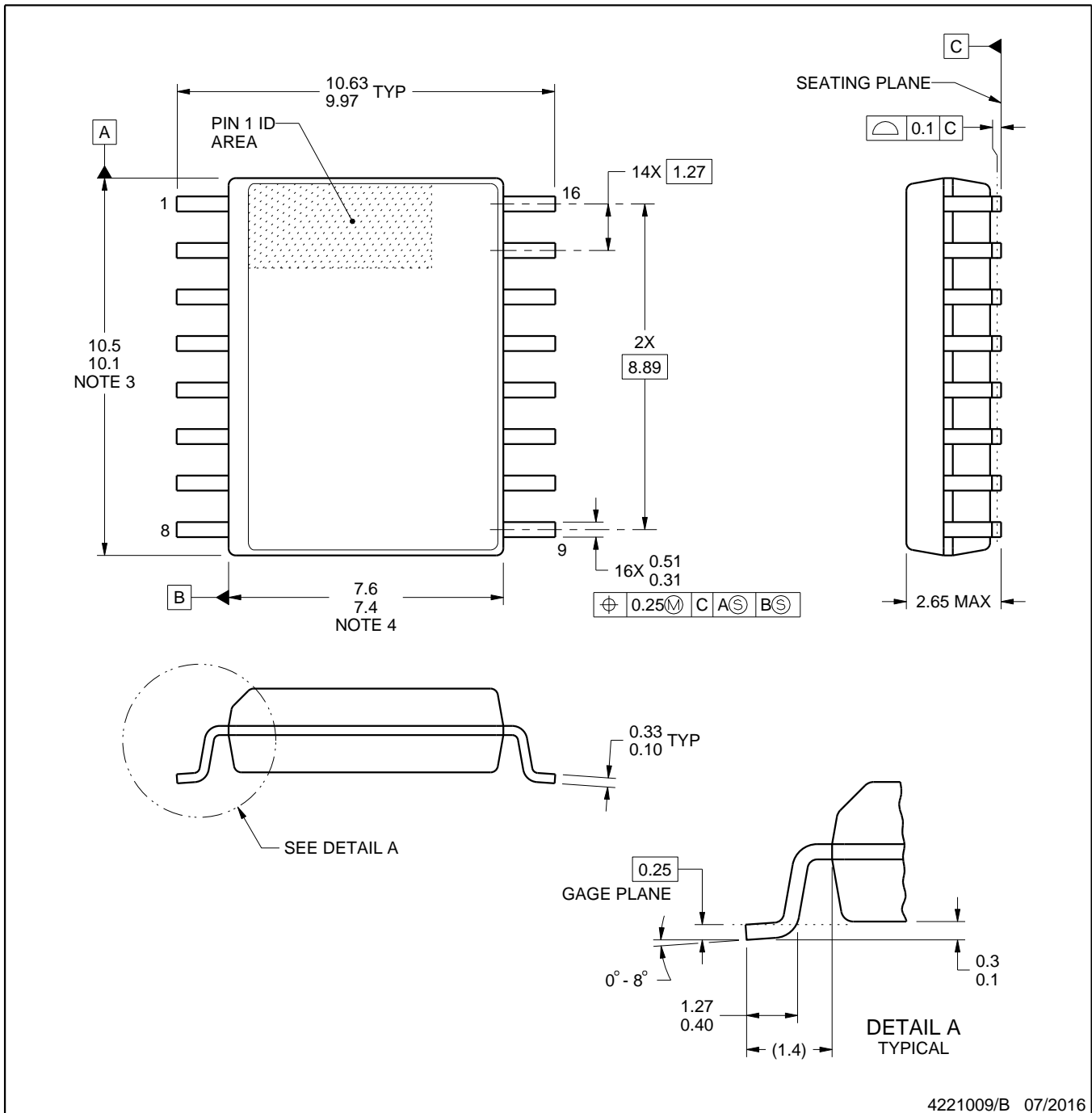

4221009/B 07/2016

### NOTES:

1. All linear dimensions are in millimeters. Dimensions in parenthesis are for reference only. Dimensioning and tolerancing per ASME Y14.5M.
2. This drawing is subject to change without notice.
3. This dimension does not include mold flash, protrusions, or gate burrs. Mold flash, protrusions, or gate burrs shall not exceed 0.15 mm, per side.
4. This dimension does not include interlead flash. Interlead flash shall not exceed 0.25 mm, per side.
5. Reference JEDEC registration MS-013.

# EXAMPLE BOARD LAYOUT

DW0016B

SOIC - 2.65 mm max height

SOIC

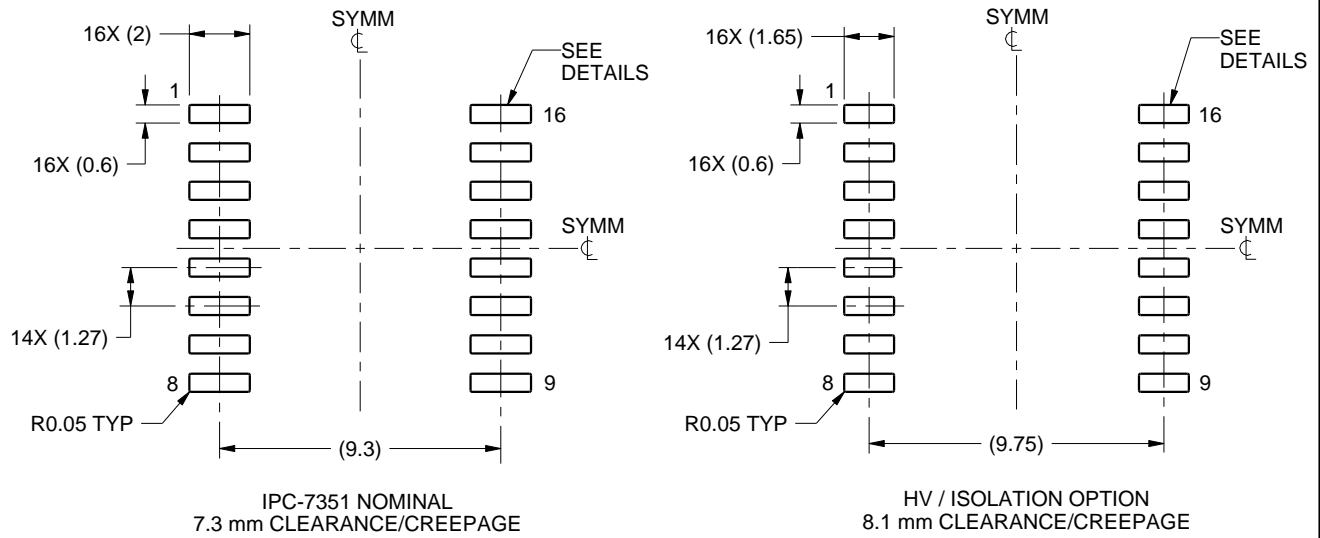

LAND PATTERN EXAMPLE  
SCALE:4X

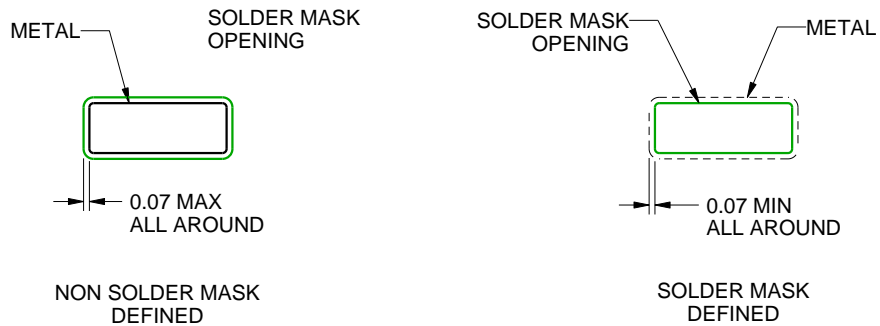

SOLDER MASK DETAILS

4221009/B 07/2016

NOTES: (continued)

- 6. Publication IPC-7351 may have alternate designs.
- 7. Solder mask tolerances between and around signal pads can vary based on board fabrication site.

# EXAMPLE STENCIL DESIGN

DW0016B

SOIC - 2.65 mm max height

SOIC

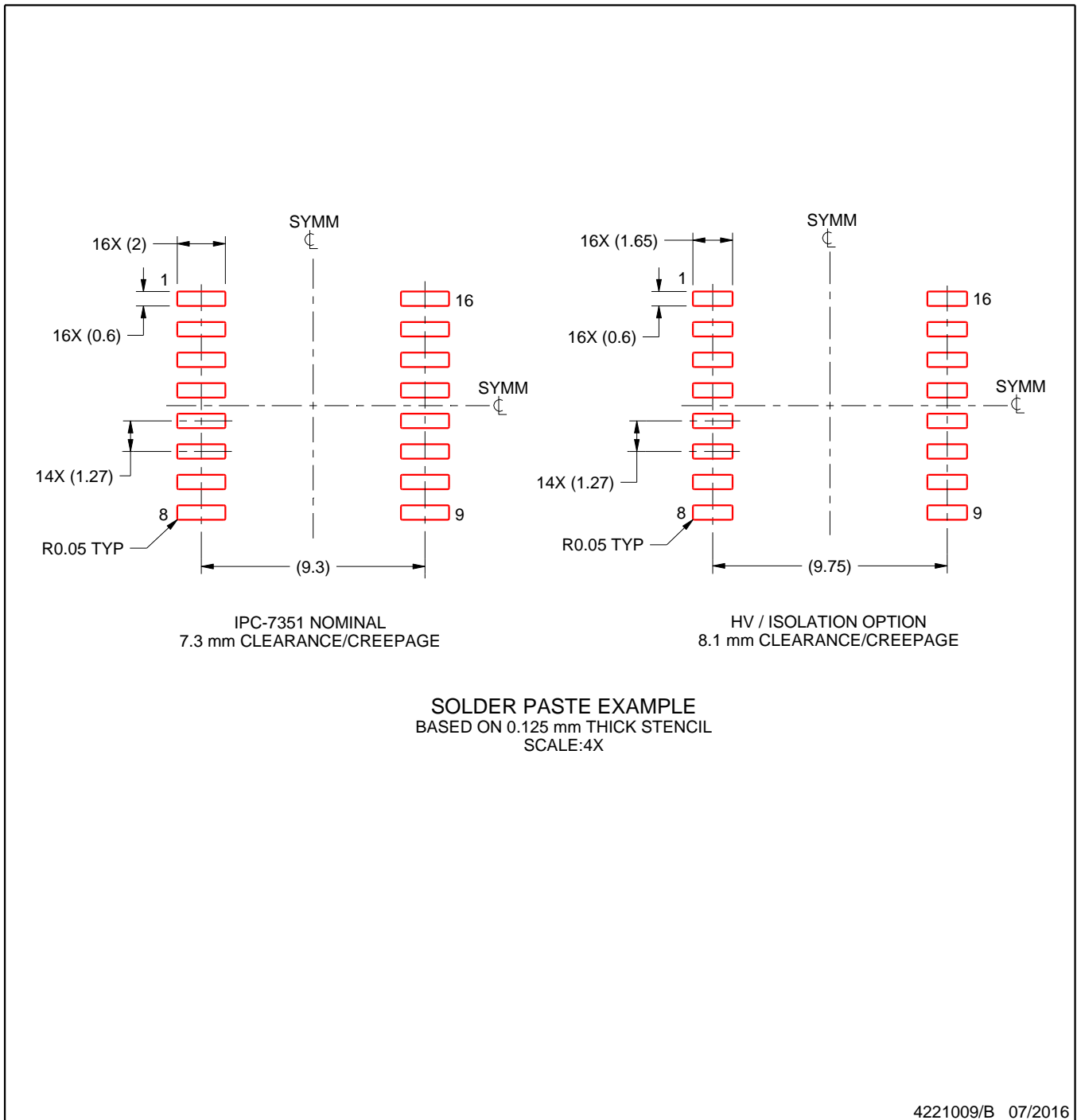

NOTES: (continued)

8. Laser cutting apertures with trapezoidal walls and rounded corners may offer better paste release. IPC-7525 may have alternate design recommendations.
9. Board assembly site may have different recommendations for stencil design.

## IMPORTANT NOTICE AND DISCLAIMER

TI PROVIDES TECHNICAL AND RELIABILITY DATA (INCLUDING DATASHEETS), DESIGN RESOURCES (INCLUDING REFERENCE DESIGNS), APPLICATION OR OTHER DESIGN ADVICE, WEB TOOLS, SAFETY INFORMATION, AND OTHER RESOURCES "AS IS" AND WITH ALL FAULTS, AND DISCLAIMS ALL WARRANTIES, EXPRESS AND IMPLIED, INCLUDING WITHOUT LIMITATION ANY IMPLIED WARRANTIES OF MERCHANTABILITY, FITNESS FOR A PARTICULAR PURPOSE OR NON-INFRINGEMENT OF THIRD PARTY INTELLECTUAL PROPERTY RIGHTS.

These resources are intended for skilled developers designing with TI products. You are solely responsible for (1) selecting the appropriate TI products for your application, (2) designing, validating and testing your application, and (3) ensuring your application meets applicable standards, and any other safety, security, or other requirements. These resources are subject to change without notice. TI grants you permission to use these resources only for development of an application that uses the TI products described in the resource. Other reproduction and display of these resources is prohibited. No license is granted to any other TI intellectual property right or to any third party intellectual property right. TI disclaims responsibility for, and you will fully indemnify TI and its representatives against, any claims, damages, costs, losses, and liabilities arising out of your use of these resources.

TI's products are provided subject to TI's Terms of Sale ([www.ti.com/legal/termsofsale.html](http://www.ti.com/legal/termsofsale.html)) or other applicable terms available either on [ti.com](http://ti.com) or provided in conjunction with such TI products. TI's provision of these resources does not expand or otherwise alter TI's applicable warranties or warranty disclaimers for TI products.

Mailing Address: Texas Instruments, Post Office Box 655303, Dallas, Texas 75265  
Copyright © 2019, Texas Instruments Incorporated

## Looking for pricing, stock, or lifecycle information?

Click below to explore more details on WIN SOURCE:

⊖ [View AMC1305M25DW](#) on WIN SOURCE

⊖ [Texas Instruments](#) Information

## Optimize Your Supply Chain with WIN SOURCE Solutions

- ✓ Global Sourcing Solution
- ✓ Obsolete Management
- ✓ Cost Control Management
- ✓ Shortage Management
- ✓ Alternative Solution
- ✓ Excess Inventory Management