



THE DATASHEET OF FAN7315G



FAN7315

LCD Back Light Inverter Drive IC

Features

- Wide Dimming Range
 - Analog dimming (2.5 : 1)
 - Burst dimming (>100 : 1)
- High Efficiency Single Stage Power Conversion
- Wide Input Voltage Range 7.4V to 20V
- Back Light Lamp Ballast and Soft Dimming
- Few External Components
- Precision Voltage Reference Trimmed to 2%
- ZVS full-bridge topology
- Soft Start
- PWM Control at fixed frequency
- Analog, Burst Dimming Function
- Open Lamp Protection
- Open Lamp Regulation
- Short Lamp Protection
- Thermal Protection
- 20 Pin SSOP

Description

The FAN7315 provides all the control functions for a series parallel resonant converter and also contains a pulse width modulation (PWM) controller to develop a supply voltage. Typical operating frequency range is between 30kHz and 250kHz depending on the CCFL and the transformer's characteristics.



Internal Block Diagram

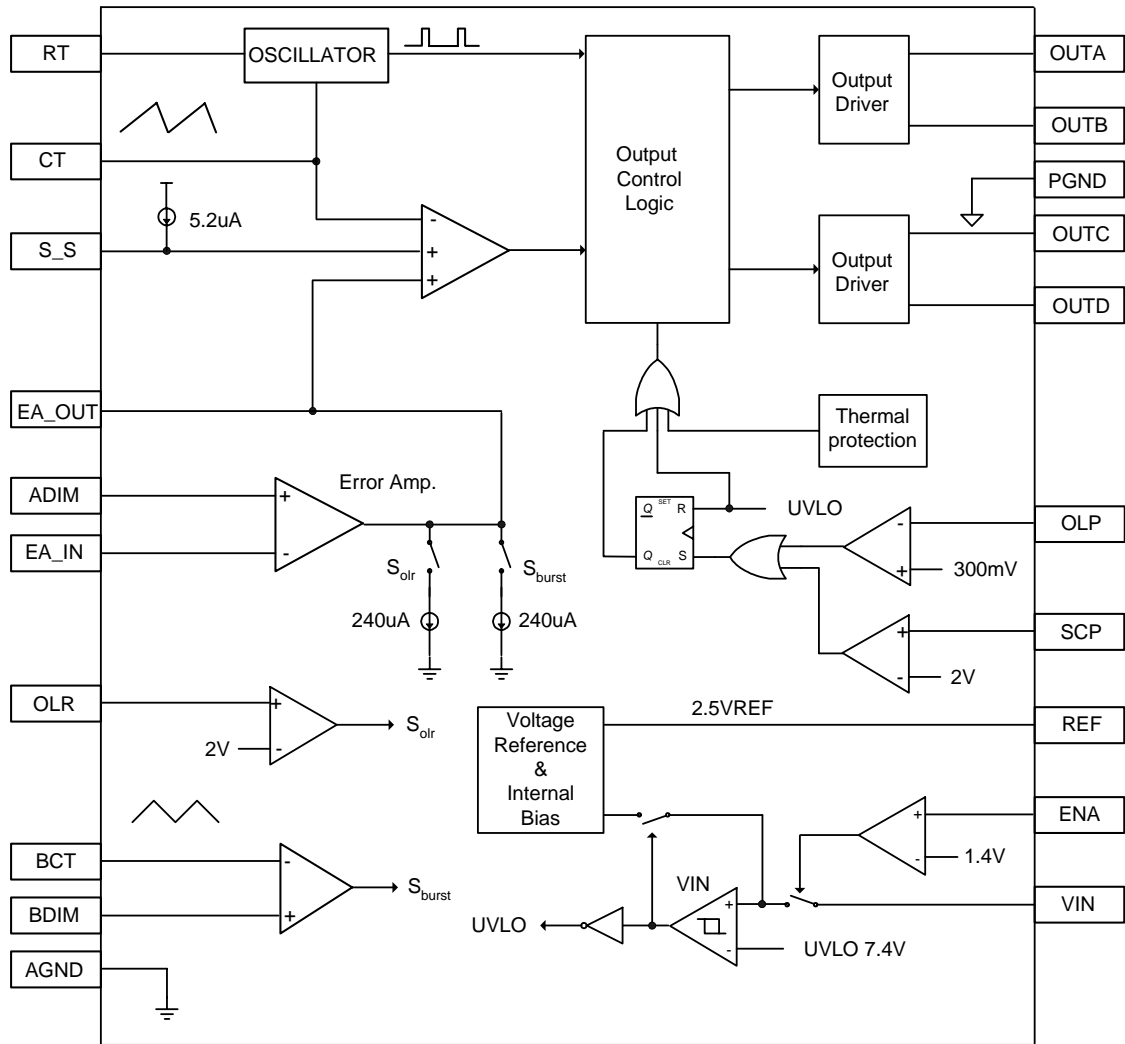

Pin Assignments



Pin Definitions

No	Name	Function Description	No	Name	Function Description
1	OLP	Open Lamp Protection	11	BCT	Burst Dimming Timing Capacitor
2	OLR	Open Lamp Regulation	12	RT	Timing Resistor
3	ENA	Enable Input	13	CT	Timing Capacitor
4	S/S	Soft Start	14	OUTD	NMOSFET Drive Output D
5	AGND	Analog Ground	15	OUTC	PMOSFET Drive Output C
6	V25	2.5V Reference Voltage	16	PGND	Power Ground
7	ADIM	Analog Dimming Input	17	VIN	Supply Voltage
8	BDIM	Burst Dimming Input	18	OUTA	PMOSFET Drive Output A
9	EA_IN	Error Amplifier Input	19	OUTB	NMOSFET Drive Output B
10	EA_OUT	Error Amplifier Output	20	SCP	Short Circuit Protection

Absolute Maximum Ratings

V_{CC}=12V, for typical values T_a=25°C, for min/max values T_a is the operating ambient temperature range with -40°C ≤ T_a ≤ 85°C and 7.4V ≤ V_{CC} ≤ 20V, unless otherwise specified.

Characteristics	Symbol	Value	Unit
Supply Voltage	V _{CC}	7.4 ~ 20	V
Operating Temperature Range	T _{opr}	-40 ~ 85	°C
Storage Temperature Range	T _{stg}	-65 ~ 150	°C
Thermal Resistance Junction-Air (Note1,2)	R _{θJA}	112	°C/W
Power Dissipation	P _d	1.1	W

Note:

1. Thermal resistance test board
Size: 76.2mm * 114.3mm * 1.6mm(1S0P)
JEDEC standard: JESD51-3, JESD51-7
2. Assume no ambient airflow

Electrical Characteristics

V_{CC}=12V, for typical values Ta=25°C, for min/max values Ta is the operating ambient temperature range with -40°C ≤ Ta ≤ 85°C and 7.4V ≤ V_{CC} ≤ 20V, unless otherwise specified.

Characteristics	Symbol	Test Condition	Min.	Typ.	Max.	Unit
REFERENCE SECTION						
Load Regulation	ΔV _{25load}	0 ≤ I ₂₅ ≤ 3mA	-	2	25	mV
Line Regulation	ΔV _{25line}	7.4V ≤ V _{CC} ≤ 20V	-	2	25	mV
2.5V Regulation Voltage	V ₂₅	-	2.44	2.49	2.54	V
OSCILLATOR SECTION(MAIN)						
Oscillation Frequency	fosc	Ta=25°C, Ct = 330pF, Rt = 45k	93	100	107	kHz
		Ct = 330pF, Rt = 45k	89	100	111	kHz
CT High Voltage	V _{cth}	-	-	1.95	-	V
CT Low Voltage	V _{ctl}	-	-	0.5	-	V
OSCILLATOR SECTION(BURST)						
Oscillation Frequency	fosc _b	C _{tb} = 6.8nF, R _t =45k	150	191	232	Hz
BCT High Voltage	V _{bcth}	-	-	2	-	V
BCT Low Voltage	V _{bctl}	-	-	0.5	-	V
ERROR AMP SECTION						
Error Amp Transconductance(Note1)	G _m	V _a = 1~2.5V	100	360	600	umho
Output Sink Current	I _{sin}	EA_OUT = 1V	44	73	100	uA
Output Source Current	I _{sur}	EA_OUT = 1V	33	50	67	uA
Open Lamp Regulation Current	I _{olr}	OLR=2.5V	160	240	320	uA
EA_OUT High Volgate	V _{ea_outh}		2.2	2.5	2.8	V
SOFT START SECTION						
Soft Start Current	I _{ss}	S _S =0V	3.5	5.2	6.9	uA
Soft Start Clamping Voltage	V _{ssh}	-	2.2	2.55	2.9	V
PROTECTION SECTION						
Open Lamp Protection Voltage	V _{olp}	-	245	300	425	mV
Open Lamp Regulation Voltage	V _{olr}	-	1.8	2	2.2	V
Short Circuit Protection Voltage	V _{scp}	-	1.75	2	2.25	V
Thermal Shutdown On Temp.(Note1)	TSD _{on}	-	130	150	170	°C
TSD Hysterisis(Note1)	TSD _{hy}	-	-	30	-	°C
UNDER VOLTAGE LOCK OUT SECTION						
Start Threshold Voltage On	V _{thon}	-	5.2	6.3	7.4	V
UVLO Hysteresis	V _{hys}	-	100	300	500	mV
Start Up Current	I _{st}	V _{CC} = V _{th} -0.2V	48	85	122	uA
Operating Supply Current	I _{op}	V _{CC} = 12V	-	-	2	mA
Stand-by Current	I _{sb}	V _{CC} = 12V, ENA=0V	55	80	105	uA

Electrical Characteristics (Continued)

V_{CC}=12V, for typical values T_a=25°C, for min/max values T_a is the operating ambient temperature range with -40°C ≤ T_a ≤ 85°C and 7.4V ≤ V_{CC} ≤ 20V, unless otherwise specified.

Characteristics	Symbol	Test Condition	Min.	Typ.	Max.	Unit
ON/OFF SECTION						
Off State Input Voltage	V _{off}	-	-	-	0.7	V
On State Input Voltage	V _{on}	-	2.1	-	-	V
OUTPUT SECTION						
PMOS Gate High Voltage	V _{pdhv}	V _{CC} =12V	-	V _{CC}	-	V
PMOS Gate Low Voltage	V _{pdlv}	V _{CC} =12V	V _{CC} -7.25	V _{CC} -6.5	V _{CC} -5.55	
NMOS Gate High Voltage	V _{ndhv}	V _{CC} = 12V	5.55	6.5	7.25	V
NMOS Gate Low Voltage	V _{ndlv}	V _{CC} =12V			0.2	
PMOS Gate Voltage With UVLO Activated	V _{puv}	V _{CC} = V _{th} -0.5V	V _{CC} -0.2	-	-	V
NMOS Gate Voltage With UVLO Activated	V _{nuv}	V _{CC} = V _{th} -0.5V	-	-	0.2	
Rising Time(Note1)	T _r	V _{CC} = 12V, C _{load} =1700pF	-	100	300	ns
Falling Time(Note1)	T _f	V _{CC} = 12V, C _{load} =1700pF	-	100	300	ns
Max./Min Overlap						
Min. Overlap between diagonal switches(Note1)		f _{osc} =100KHz	-	0	-	%
Max. Overlap between diagonal switches(Note1)		f _{osc} =100KHz	-	100	-	%
Delay Time						
PDR_A/NDR_B(Note1)		f _{osc} =100KHz, R _t =45k	-	325	-	ns
PDR_C/NDR_D(Note1)		f _{osc} =100KHz, R _t =45k	-	325	-	ns

Note:

1. These parameters, although guaranteed, are not 100% tested in production.

Ordering Information

Product number	Package	Operating Temperature
FAN7315G	20-SSOP	-40°C ~ 85°C

DISCLAIMER

FAIRCHILD SEMICONDUCTOR RESERVES THE RIGHT TO MAKE CHANGES WITHOUT FURTHER NOTICE TO ANY PRODUCTS HEREIN TO IMPROVE RELIABILITY, FUNCTION OR DESIGN. FAIRCHILD DOES NOT ASSUME ANY LIABILITY ARISING OUT OF THE APPLICATION OR USE OF ANY PRODUCT OR CIRCUIT DESCRIBED HEREIN; NEITHER DOES IT CONVEY ANY LICENSE UNDER ITS PATENT RIGHTS, NOR THE RIGHTS OF OTHERS.

LIFE SUPPORT POLICY

FAIRCHILD'S PRODUCTS ARE NOT AUTHORIZED FOR USE AS CRITICAL COMPONENTS IN LIFE SUPPORT DEVICES OR SYSTEMS WITHOUT THE EXPRESS WRITTEN APPROVAL OF THE PRESIDENT OF FAIRCHILD SEMICONDUCTOR CORPORATION. As used herein:

1. Life support devices or systems are devices or systems which, (a) are intended for surgical implant into the body, or (b) support or sustain life, and (c) whose failure to perform when properly used in accordance with instructions for use provided in the labeling, can be reasonably expected to result in a significant injury of the user.
2. A critical component in any component of a life support device or system whose failure to perform can be reasonably expected to cause the failure of the life support device or system, or to affect its safety or effectiveness.

Looking for pricing, stock, or lifecycle information?

Click below to explore more details on WIN SOURCE:

- [View FAN7315G on WIN SOURCE](#)
- [Fairchild/ON Semiconductor Information](#)

Optimize Your Supply Chain with WIN SOURCE Solutions

- ✓ Global Sourcing Solution
- ✓ Obsolete Management
- ✓ Cost Control Management
- ✓ Shortage Management
- ✓ Alternative Solution
- ✓ Excess Inventory Management