



**THE DATASHEET OF
AN87C196JV20F8**





87C196KD 16-BIT HIGH PERFORMANCE CHMOS MICROCONTROLLER

Automotive

- -40°C to +125°C
- 32 Kbytes of On-Chip EPROM
- 232 Byte Register File
- 768 Bytes of Additional RAM
- Register-to-Register Architecture
- 28 Interrupt Sources/16 Vectors
- Peripheral Transaction Server
- 1.75 μ s 16 x 16 Multiply (16 MHz)
- 3.0 μ s 32/16 Divide (16 MHz)
- Powerdown and Idle Modes
- Five 8-Bit I/O Ports
- 16-Bit Watchdog Timer
- Dynamically Configurable 8-Bit or 16-Bit Buswidth
- Full Duplex Serial Port
- High Speed I/O Subsystem
- 16-Bit Timer
- 16-Bit Up/Down Counter with Capture
- 3 Pulse-Width-Modulated Outputs
- Four 16-Bit Software Timers
- 8- or 10-Bit 8-Channel A/D Converter with Sample/Hold
- HOLD/HLDA Bus Protocol
- OTP One-Time Programmable and QROM Versions
- Available in 12 MHz and 16 MHz Versions
- 16 MHz Operation

The 87C196KD 16-bit microcontroller is a high-performance member of the MCS® 96 microcontroller family. The 87C196KD is an enhanced 8XC196KC device with 1000 bytes RAM, 16 MHz operation and 32 Kbytes of on-chip EPROM. Intel's CHMOS process provides a high-performance processor along with low power consumption.

Four high-speed capture inputs are provided to record times when events occur. Six high-speed outputs are available for pulse or waveform generation. The high-speed output can also generate four software timers or start an A/D conversion. Events can be based on the timer or up/down counter.

NOTICE:

This datasheet contains information on products in full production. Specifications within this datasheet are subject to change without notice. Verify with your local Intel sales office that you have the latest datasheet before finalizing a design.

MCS® 96 is a registered trademark of Intel Corporation.

*Other brands and names are the property of their respective owners.
Information in this document is provided in connection with Intel products. Intel assumes no liability whatsoever, including infringement of any patent or copyright, for sale and use of Intel products except as provided in Intel's Terms and Conditions of Sale for such products. Intel retains the right to make changes to these specifications at any time, without notice. Microcomputer Products may have minor variations to this specification known as errata.
COPYRIGHT © INTEL CORPORATION, 1995

January 1995

Order Number: 272168-002

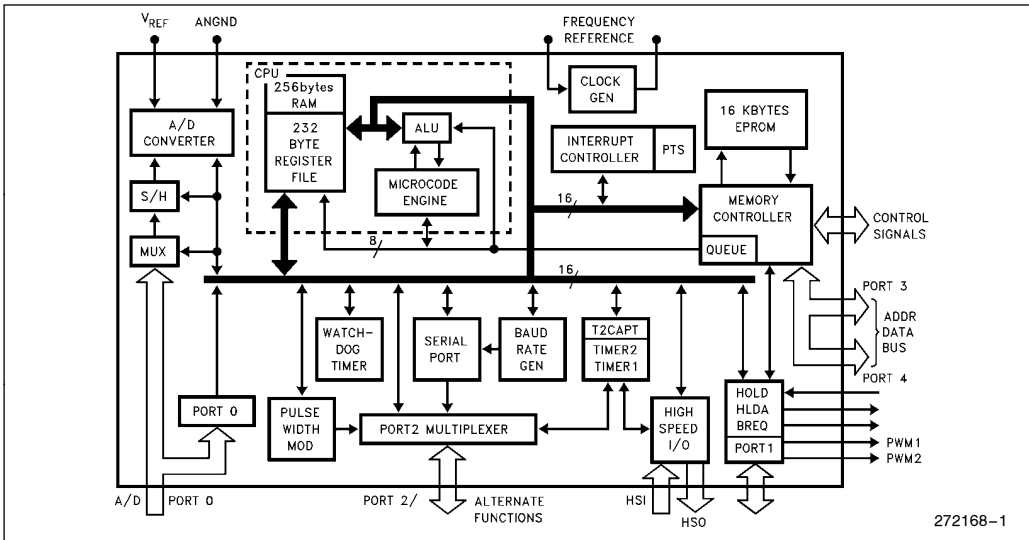

Figure 1. 87C196KD Block Diagram

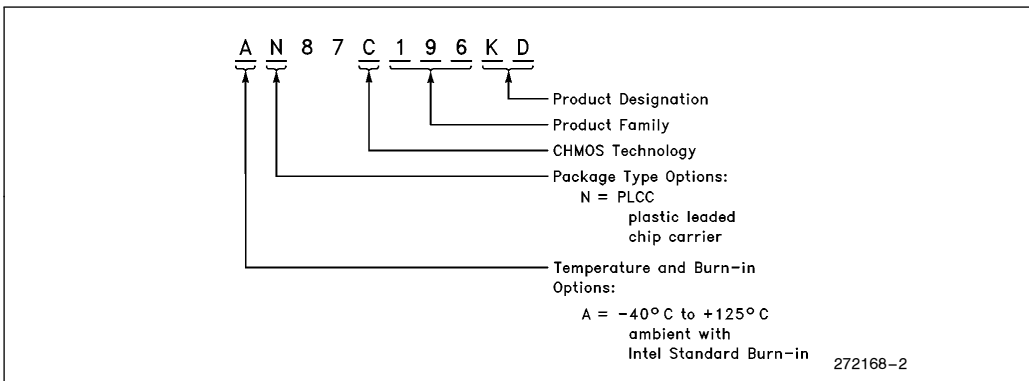

Figure 2. The 87C196KD Family Nomenclature

87C196KD Enhanced Feature Set over the 87C196KC

1. The 87C196KD has twice the RAM and twice the EPROM of the 87C196KC.
2. The vertical windowing scheme has been extended to allow all 1000 bytes of register RAM to be windowed into the lower register file.
3. A CLKOUT disable bit has been added to the IOC3 SFR. This can be used to reduce noise in systems not requiring the CLKOUT signal.

PACKAGING

PLCC	Description	PLCC	Description	PLCC	Description
9	ACH7/P0.7	54	AD6/P3.6	31	P1.6/ $\overline{\text{HLDA}}$
8	ACH6/P0.6	53	AD7/P3.7	30	P1.5/ $\overline{\text{BREQ}}$
7	ACH2/P0.2	52	AD8/P4.0	29	HSO.1
6	ACH0/P0.0	51	AD9/P4.1	28	HSO.0
5	ACH1/P0.1	50	AD10/P4.2	27	HSO.5/HSI.3
4	ACH3/P0.3	49	AD11/P4.3	26	HSO.4/HSI.2
3	NMI	48	AD12/P4.4	25	HSI.1
2	$\overline{\text{EA}}$	47	AD13/P4.5	24	HSI.0
1	V _{CC}	46	AD14/P4.6	23	P1.4/PWM2
68	V _{SS}	45	AD15/P4.7	22	P1.3/PWM1
67	XTAL1	44	T2CLK/P2.3	21	P1.2
66	XTAL2	43	READY	20	P1.1
65	CLKOUT	42	T2RST/P2.4	19	P1.0
64	BUSWIDTH	41	$\overline{\text{BHE}}/\overline{\text{WRH}}$	18	TXD/P2.0
63	INST	40	$\overline{\text{WR}}/\overline{\text{WRL}}$	17	RXD/P2.1
62	ALE/ $\overline{\text{ADV}}$	39	PWM0/P2.5	16	$\overline{\text{RESET}}$
61	$\overline{\text{RD}}$	38	P2.7/T2CAPTURE	15	EXTINT/P2.2
60	AD0/P3.0	37	V _{PP}	14	V _{SS}
59	AD1/P3.1	36	V _{SS}	13	V _{REF}
58	AD2/P3.2	35	HSO.3	12	ANGND
57	AD3/P3.3	34	HSO.2	11	ACH4/P.04
56	AD4/P3.4	33	P2.6/T2UP-DN	10	ACH5/P.05
55	AD5/P3.5	32	P1.7/ $\overline{\text{HOLD}}$		

Figure 3. 68-Pin PLCC Functional Pin-out

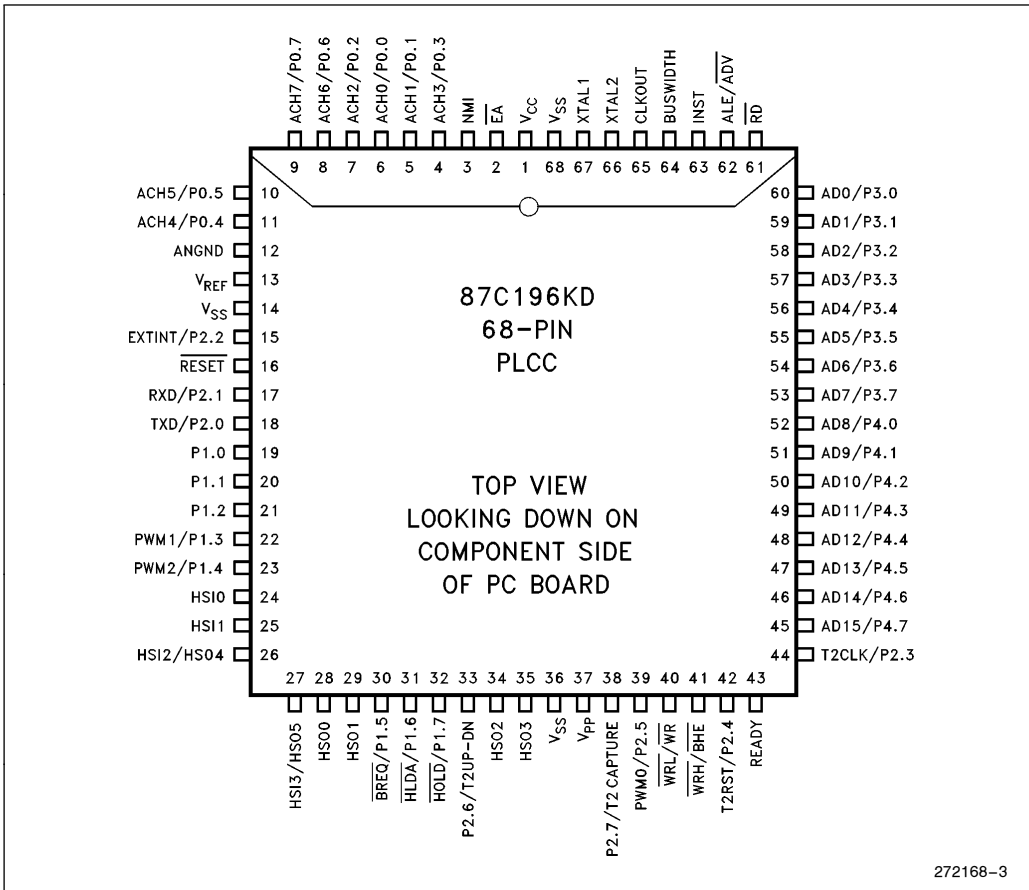

Figure 4. 68-Pin PLCC Package

Table 1. Prefix Identification

PLCC	
87C196KD	AN87C196KD*

*OTP Version

PIN DESCRIPTIONS

Symbol	Name and Function
V _{CC}	Main supply voltage (5V).
V _{SS}	Digital circuit ground (0V). There are three V _{SS} pins, all of which must be connected.
V _{REF}	Reference voltage for the A/D converter (5V). V _{REF} is also the supply voltage to the analog portion of the A/D converter and the logic used to read Port 0. Must be connected for A/D and Port 0 to function.
ANGND	Reference ground for the A/D converter. Must be held at nominally the same potential as V _{SS} .
V _{PP}	Timing pin for the return from powerdown circuit. Connect this pin with a 1 μF capacitor to V _{SS} and a 1 MΩ resistor to V _{CC} . If this function is not used V _{PP} may be tied to V _{CC} . This pin is the programming voltage on the EPROM device.
XTAL1	Input of the oscillator inverter and of the internal clock generator.
XTAL2	Output of the oscillator inverter.
CLKOUT	Output of the internal clock generator. The frequency of CLKOUT is 1/2 the oscillator frequency.
$\overline{\text{RESET}}$	Reset input to the chip.
BUSWIDTH	Input for buswidth selection. If CCR bit 1 is a one, this pin selects the bus width for the bus cycle in progress. If BUSWIDTH is a 1, a 16-bit bus cycle occurs. If BUSWIDTH is a 0 an 8-bit cycle occurs. If CCR bit 1 is a 0, the bus is always an 8-bit bus.
NMI	A positive transition causes a vector through 203EH.
INST	Output high during an external memory read indicates the read is an instruction fetch. INST is valid throughout the bus cycle. INST is activated only during external memory accesses and output low for a data fetch.
$\overline{\text{EA}}$	Input for memory select (External Access). $\overline{\text{EA}}$ equal to a TTL-high causes memory accesses to locations 2000H through 5FFFH to be directed to on-chip ROM/EPROM. $\overline{\text{EA}}$ equal to a TTL-low causes accesses to those locations to be directed to off-chip memory.
ALE/ $\overline{\text{ADV}}$	Address Latch Enable or Address Valid output, as selected by CCR. Both pin options provide a signal to demultiplex the address from the address/data bus. When the pin is $\overline{\text{ADV}}$, it goes inactive high at the end of the bus cycle. ALE/ $\overline{\text{ADV}}$ is activated only during external memory accesses.
$\overline{\text{RD}}$	Read signal output to external memory. $\overline{\text{RD}}$ is activated only during external memory reads.
$\overline{\text{WR}}$ / $\overline{\text{WRL}}$	Write and Write Low output to external memory, as selected by the CCR. $\overline{\text{WR}}$ will go low for every external write, while $\overline{\text{WRL}}$ will go low only for external writes where an even byte is being written. $\overline{\text{WR}}$ / $\overline{\text{WRL}}$ is activated only during external memory writes.
$\overline{\text{BHE}}$ / $\overline{\text{WRH}}$	Bus High Enable or Write High output to external memory, as selected by the CCR. $\overline{\text{BHE}} = 0$ selects the bank of memory that is connected to the high byte of the data bus. $\text{A0} = 0$ selects the bank of memory that is connected to the low byte of the data bus. Thus accesses to a 16-bit wide memory can be to the low byte only ($\text{A0} = 0$, $\overline{\text{BHE}} = 1$), to the high byte only ($\text{A0} = 1$, $\overline{\text{BHE}} = 0$), or both bytes ($\text{A0} = 0$, $\overline{\text{BHE}} = 0$). If the $\overline{\text{WRH}}$ function is selected, the pin will go low if the bus cycle is writing to an odd memory location. $\overline{\text{BHE}}$ / $\overline{\text{WRH}}$ is valid only during 16-bit external memory write cycles.





PIN DESCRIPTIONS (Continued)

Symbol	Name and Function
READY	Ready input to lengthen external memory cycles, for interfacing to slow or dynamic memory, or for bus sharing. When the external memory is not being used, READY has no effect.
HSI	Inputs to High Speed Input Unit. Four HSI pins are available: HSI.0, HSI.1, HSI.2 and HSI.3. Two of them (HSI.2 and HSI.3) are shared with the HSO Unit.
HSO	Outputs from High Speed Output Unit. Six HSO pins are available: HSO.0, HSO.1, HSO.2, HSI.3, HSO.4 and HSO.5. Two of them (HSO.4 and HSO.5) are shared with the HSI Unit.
Port 0	8-bit high impedance input-only port. These pins can be used as digital inputs and/or as analog inputs to the on-chip A/D converter.
Port 1	8-bit quasi-bidirectional I/O port.
Port 2	8-bit multi-functional port. All of its pins are shared with other functions in the 87C196KD.
Ports 3 and 4	8-bit bidirectional I/O ports with open drain outputs. These pins are shared with the multiplexed address/data bus.
$\overline{\text{HOLD}}$	Bus Hold input requesting control of the bus.
$\overline{\text{HLDA}}$	Bus Hold acknowledge output indicating release of the bus.
$\overline{\text{BREQ}}$	Bus Request output activated when the bus controller has a pending external memory cycle.





ELECTRICAL CHARACTERISTICS

NOTICE: This is a production data sheet. The specifications are subject to change without notice.

Absolute Maximum Ratings*

- Ambient Temperature
Under Bias -40°C to +125°C
- Storage Temperature -65°C to +150°C
- Voltage On Any Pin to V_{SS}
Except E_A and V_{PP} -0.5V to +7.0V
- Voltage from E_A or
V_{PP} to V_{SS} -0.5V to +13.0V
- Power Dissipation 0.43W

**WARNING: Stressing the device beyond the "Absolute Maximum Ratings" may cause permanent damage. These are stress ratings only. Operation beyond the "Operating Conditions" is not recommended and extended exposure beyond the "Operating Conditions" may affect device reliability.*

OPERATING CONDITIONS

Symbol	Description	Min	Max	Units
T _A	Ambient Temperature Under Bias	-40	+125	°C
V _{CC}	Digital Supply Voltage	4.50	5.50	V
V _{REF}	Analog Supply Voltage	4.50	5.50	V
F _{OSC}	Oscillator Frequency	4	16	MHz

NOTE:
ANGND and V_{SS} should be nominally at the same potential.

DC CHARACTERISTICS (Over Specified Operating Conditions)

Symbol	Description	Min	Max	Units	Test Conditions
V _{IL}	Input Low Voltage	-0.5	0.8	V	
V _{IH}	Input High Voltage (Note 1)	0.2 V _{CC} + 1.0	V _{CC} + 0.5	V	
V _{IH1}	Input High Voltage on XTAL 1, EA	0.7 V _{CC}	V _{CC} + 0.5	V	
V _{IH2}	Input High Voltage on RESET	2.2	V _{CC} + 0.5	V	
V _{OL}	Output Low Voltage		0.3 0.45 1.5	V	I _{OL} = 200 μA I _{OL} = 2.8 mA I _{OL} = 7 mA
V _{OL1}	Output Low Voltage in RESET on P2.5 (Note 2)		0.8	V	I _{OL} = +0.2 mA
V _{OH}	Output High Voltage (Standard Outputs)	V _{CC} - 0.3 V _{CC} - 0.7 V _{CC} - 1.5		V	I _{OH} = -200 μA I _{OH} = -3.2 mA I _{OH} = -7 mA
V _{OH1}	Output High Voltage (Quasi-bidirectional Outputs)	V _{CC} - 0.3 V _{CC} - 0.7 V _{CC} - 1.5		V	I _{OH} = -10 μA I _{OH} = -30 μA I _{OH} = -60 μA
I _{OH2}	Output High Current In RESET on P2.0 (Note 2)	-0.8		mA	V _{IH} = V _{CC} - 1.5 V

- NOTES:**
1. All pins except RESET, XTAL1 and EA.
 2. Violating these specifications in Reset may cause the part to enter test modes.





DC CHARACTERISTICS (Over Specified Operating Conditions)

Symbol	Description	Min	Typ	Max	Units	Test Conditions
I_{LI}	Input Leakage Current (Std. Inputs)			± 10	μA	$0 < V_{IN} < V_{CC} - 0.3V$
I_{LI1}	Input Leakage Current (Port 0)			± 3	μA	$0 < V_{IN} < V_{REF}$
I_{TL}	1 to 0 Transition Current (QBD Pins)			-650	μA	$V_{IN} = 2.0V$
I_{IL}	Logical 0 Input Current (QBD Pins)			-70	μA	$V_{IN} = 0.45V$
I_{CC}	Active Mode Current in Reset		65	75	mA	$XTAL1 = 16\text{ MHz}$ $V_{CC} = V_{PP} = V_{REF} = 5.5V$
I_{REF}	A/D Converter Reference Current		2	5	mA	
I_{IDLE}	Idle Mode Current		15	30	mA	
R_{RST}	Reset Pullup Resistor	6K		65K	Ω	$V_{CC} = 5.0V, V_{IN} = 4.0V$
C_S	Pin Capacitance (Any Pin to V_{SS})			10	pF	

NOTES:

(Notes apply to all specifications)

- QBD (Quasi-bidirectional) pins include Port 1, P2.6 and P2.7.
- Standard Outputs include AD0-15, RD, WR, ALE, BHE, INST, HSO pins, PWM/P2.5, CLKOUT, RESET, Ports 3 and 4, TXD/P2.0 and RXD (in serial mode 0). The V_{OH} specification is not valid for RESET. Ports 3 and 4 are open-drain outputs.
- Standard Inputs include HSI pins, READY, BUSWIDTH, NMI, RXD/P2.1, EXTINT/P2.2, T2CLK/P2.3 and T2RST/P2.4.
- Maximum current per pin must be externally limited to the following values if V_{OL} is held above 0.45V or V_{OH} is held below $V_{CC} - 0.7V$:
 - I_{OL} on Output pins: 10 mA
 - I_{OH} on quasi-bidirectional pins: self limiting
 - I_{OH} on Standard Output pins: 10 mA
- Maximum current per bus pin (data and control) during normal operation is ± 3.2 mA.
- During normal (non-transient) conditions the following total current limits apply:

Port 1, P2.6	I_{OL} : 29 mA	I_{OH} is self limiting
HSO, P2.0, RXD, \overline{RESET}	I_{OL} : 29 mA	I_{OH} : 26 mA
P2.5, P2.7, WR, BHE	I_{OL} : 13 mA	I_{OH} : 11 mA
AD0-AD15	I_{OL} : 52 mA	I_{OH} : 52 mA
RD, ALE, INST-CLKOUT	I_{OL} : 13 mA	I_{OH} : 13 mA



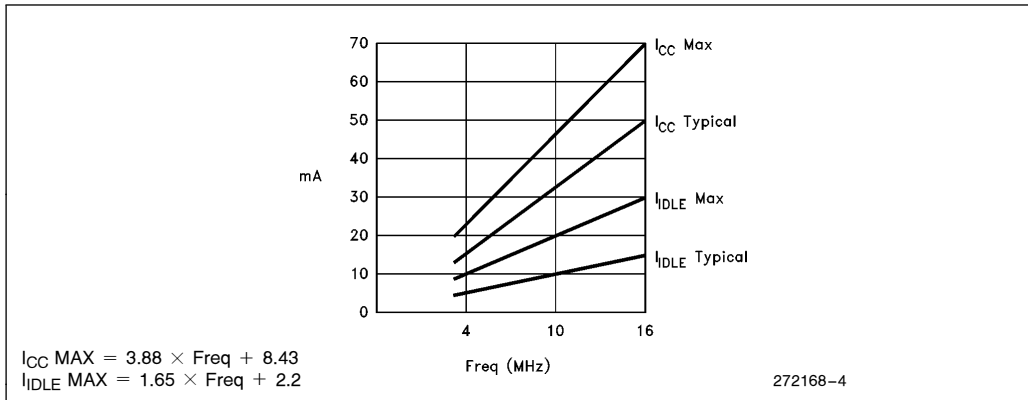

Figure 5. I_{CC} and I_{IDLE} vs Frequency

AC CHARACTERISTICS

For use over specified operating conditions.

Test Conditions: Capacitive load on all pins = 100 pF, Rise and fall times = 10 ns, F_{OSC} = 16 MHz

The system must meet these specifications to work with the 87C196KD:

Symbol	Description	Min	Max	Units	Notes
T _{AVYV}	Address Valid to READY Setup		2 T _{OSC} - 75	ns	
T _{LLYV}	ALE Low to READY Setup		T _{OSC} - 77	ns	
T _{YLYH}	Non READY Time	No upper limit		ns	
T _{CLYX}	READY Hold after CLKOUT Low	0	T _{OSC} - 30	ns	(Note 1)
T _{LLYX}	READY Hold after ALE Low	T _{OSC} - 15	2 T _{OSC} - 40	ns	(Note 1)
T _{AVGV}	Address Valid to Buswidth Setup		2 T _{OSC} - 75	ns	
T _{LLGV}	ALE Low to Buswidth Setup		T _{OSC} - 65	ns	
T _{CLGX}	Buswidth Hold after CLKOUT Low	0		ns	
T _{AVDV}	Address Valid to Input Data Valid		3 T _{OSC} - 55	ns	(Note 2)
T _{RLDV}	\overline{RD} Active to Input Data Valid		T _{OSC} - 25	ns	(Note 2)
T _{CLDV}	CLKOUT Low to Input Data Valid		T _{OSC} - 45	ns	
T _{RHDZ}	End of \overline{RD} to Input Data Float		T _{OSC}	ns	
T _{RDX}	Data Hold after \overline{RD} Inactive	0		ns	

NOTES:

1. If max is exceeded, additional wait states will occur.
2. If wait states are used, add 2 T_{OSC} * N, where N = number of wait states.



AC CHARACTERISTICS (Continued)

For use over specified operating conditions.

Test Conditions: Capacitive load on all pins = 100 pF, Rise and fall times = 10 ns, $F_{OSC} = 16$ MHz**The 87C196KD will meet these specifications:**

Symbol	Description	Min	Max	Units	Notes
F_{XTAL}	Frequency on XTAL ₁	4.0	16	MHz	(Note 1)
T_{OSC}	$1/F_{XTAL}$	62.5	250	ns	
T_{XHCH}	XTAL1 High to CLKOUT High or Low	20	110	ns	
T_{CLCL}	CLKOUT Cycle Time	$2 T_{OSC}$		ns	
T_{CHCL}	CLKOUT High Period	$T_{OSC} - 10$	$T_{OSC} + 15$	ns	
T_{CLLH}	CLKOUT Falling Edge to ALE Rising	-5	15	ns	
T_{LLCH}	ALE Falling Edge to CLKOUT Rising	-25	+15	ns	
T_{LHLH}	ALE Cycle Time	$4 T_{OSC}$		ns	(Note 4)
T_{LHLL}	ALE High Period	$T_{OSC} - 10$	$T_{OSC} + 10$	ns	
T_{AVLL}	Address Setup to ALE Falling Edge	$T_{OSC} - 15$			
T_{LLAX}	Address Hold after ALE Falling Edge	$T_{OSC} - 35$		ns	
T_{LLRL}	ALE Falling Edge to \overline{RD} Falling Edge	$T_{OSC} - 35$		ns	
T_{RLCL}	\overline{RD} Low to CLKOUT Falling Edge	0	35	ns	
T_{RLRH}	\overline{RD} Low Period	$T_{OSC} - 5$		ns	(Note 4)
T_{RHLH}	\overline{RD} Rising Edge to ALE Rising Edge	T_{OSC}	$T_{OSC} + 25$	ns	(Note 2)
T_{RLAZ}	\overline{RD} Low to Address Float		5	ns	
T_{LLWL}	ALE Falling Edge to \overline{WR} Falling Edge	$T_{OSC} - 10$		ns	
T_{CLWL}	CLKOUT Low to \overline{WR} Falling Edge	0	25	ns	
T_{QVWH}	Data Stable to \overline{WR} Rising Edge	$T_{OSC} - 30$			(Note 4)
T_{CHWH}	CLKOUT High to \overline{WR} Rising Edge	-5	15	ns	
T_{WLWH}	\overline{WR} Low Period	$T_{OSC} - 30$		ns	(Note 4)
T_{WHQX}	Data Hold after \overline{WR} Rising Edge	$T_{OSC} - 25$		ns	
T_{WHLH}	\overline{WR} Rising Edge to ALE Rising Edge	$T_{OSC} - 10$	$T_{OSC} + 15$	ns	(Note 2)
T_{WHBX}	\overline{BHE} , INST after \overline{WR} Rising Edge	$T_{OSC} - 10$		ns	
T_{WHAX}	AD8-15 HOLD after \overline{WR} Rising	$T_{OSC} - 30$		ns	(Note 3)
T_{RHBX}	\overline{BHE} , INST after \overline{RD} Rising Edge	$T_{OSC} - 10$		ns	
T_{RHAX}	AD8-15 HOLD after \overline{RD} Rising	$T_{OSC} - 25$		ns	(Note 3)

NOTES:

1. Testing performed at 4.0 MHz. However, the device is static by design and will typically operate below 1 Hz.
2. Assuming back-to-back bus cycles.
3. 8-Bit bus only.
4. If wait states are used, add $2 T_{OSC} * N$, where N = number of wait states.

System Bus Timings

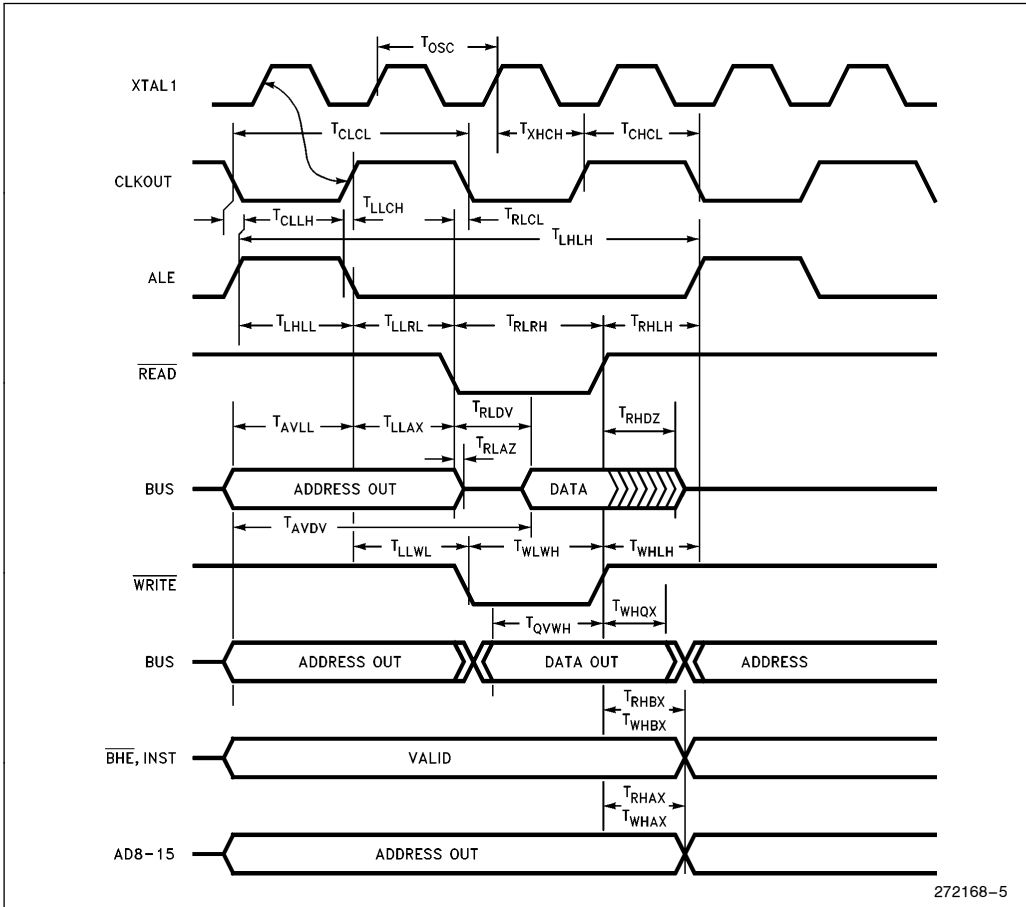

READY Timings (One Wait State)

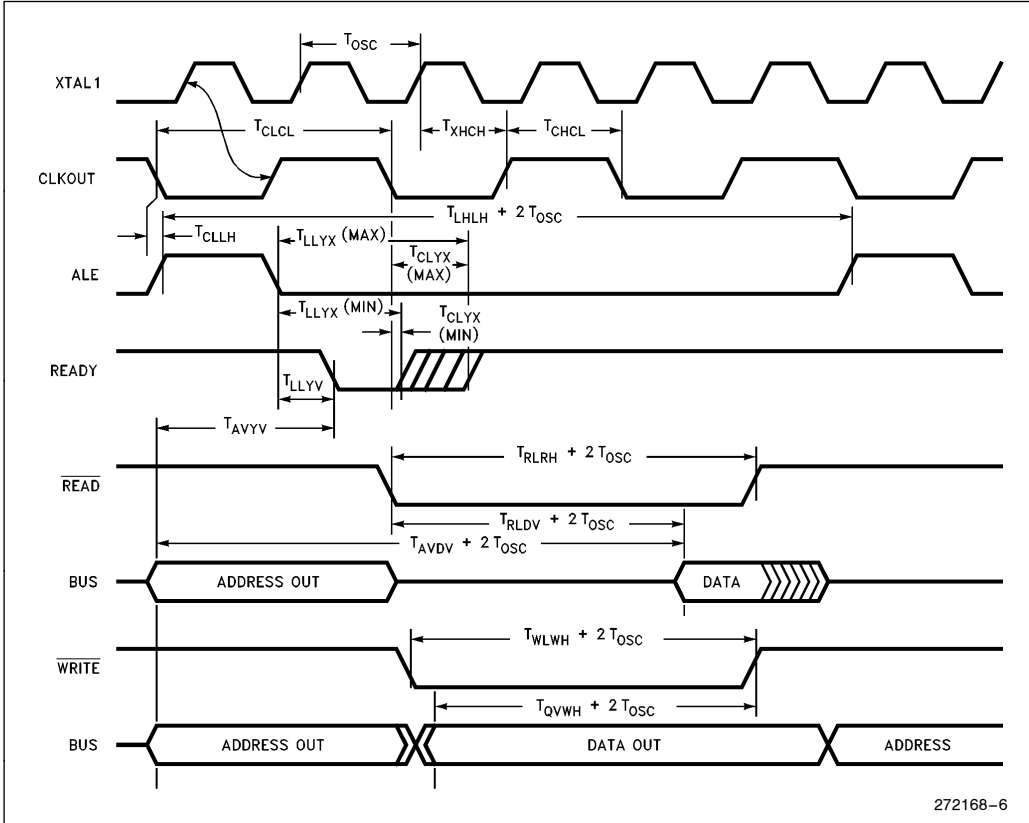

Buswidth Timings

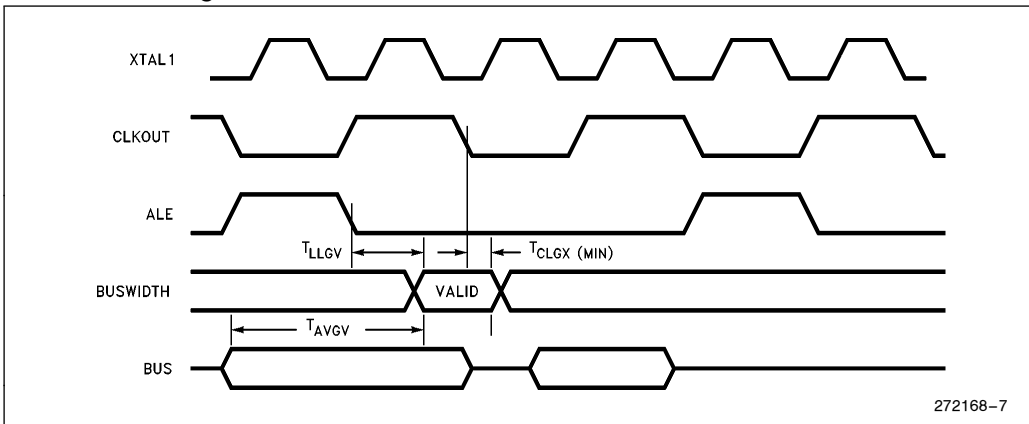

HOLD/HLDA Timings

Symbol	Description	Min	Max	Units	Notes
T _{HVCH}	HOLD Setup	60		ns	(Note 1)
T _{CLHAL}	CLKOUT Low to HLDA Low	-15	15	ns	
T _{CLBRL}	CLKOUT Low to BREQ Low	-15	15	ns	
T _{HALAZ}	HLDA Low to Address Float		15	ns	
T _{HALBZ}	HLDA Low to BHE, INST, RD, WR Weakly Driven		20	ns	
T _{CLHAH}	CLKOUT Low to HLDA High	-15	15	ns	
T _{CLBRH}	CLKOUT Low to BREQ High	-15	15	ns	
T _{HAHAX}	HLDA High to Address No Longer Float	-15		ns	
T _{HAHBV}	HLDA High to BHE, INST, RD, WR Valid	-10	15	ns	
T _{CLLH}	CLKOUT Low to ALE High	-5	15	ns	

NOTE:

1. To guarantee recognition at next clock.

DC SPECIFICATIONS IN HOLD

	Min	Max	Units
Weak Pullups on \overline{ADV} , \overline{RD} , \overline{WR} , \overline{WRL} , \overline{BHE}	50K	250K	$V_{CC} = 5.5V, V_{IN} = 0.45V$
Weak Pulldowns on ALE, INST	10K	50K	$V_{CC} = 5.5V, V_{IN} = 2.4$

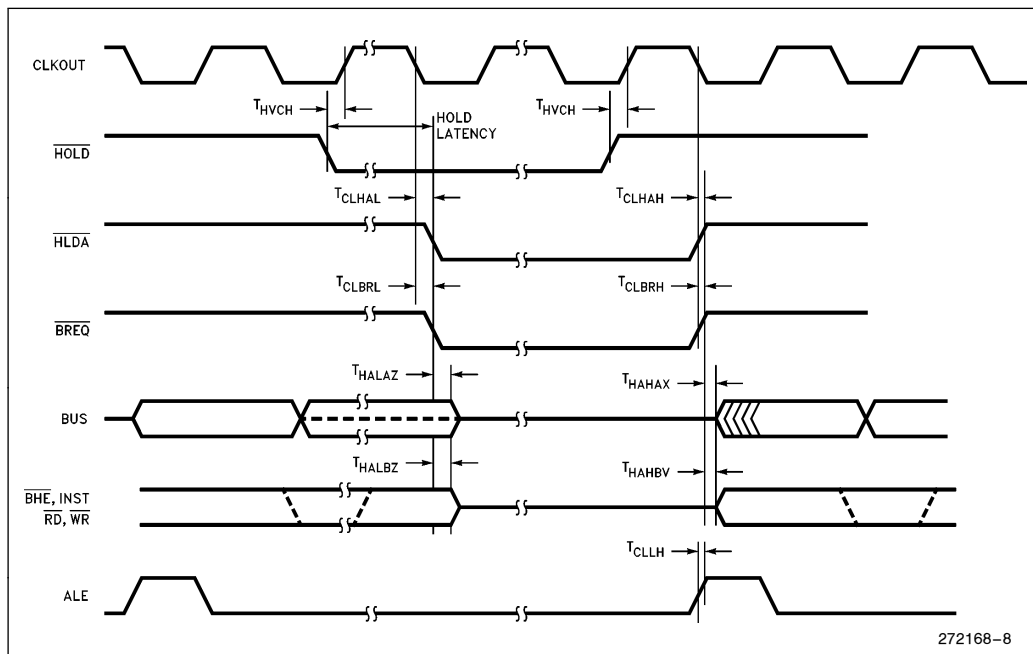

272168-8

EXTERNAL CLOCK DRIVE

Symbol	Parameter	Min	Max	Units
1/T _{XLXL}	Oscillator Frequency	4.0	16.0	MHz
T _{XLXL}	Oscillator Frequency	62.5	250	ns
T _{XHXX}	High Time	22		ns
T _{XLXX}	Low Time	22		ns
T _{XLXH}	Rise Time		10	ns
T _{XHXL}	Fall Time		10	ns

EXTERNAL CLOCK DRIVE WAVEFORMS

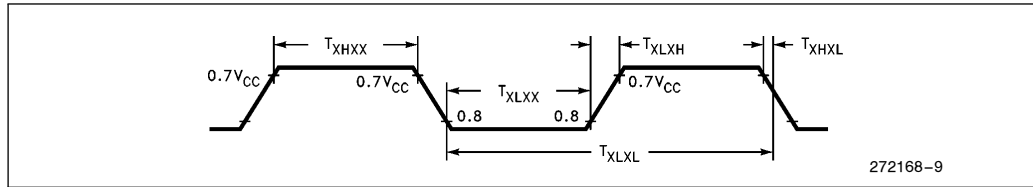

An external oscillator may encounter as much as a 100 pF load at XTAL1 when it starts-up. This is due to interaction between the amplifier and its feedback capacitance. Once the external signal meets the V_{IL} and V_{IH} specifications the capacitance will not exceed 20 pF.

AC TESTING INPUT, OUTPUT WAVEFORMS

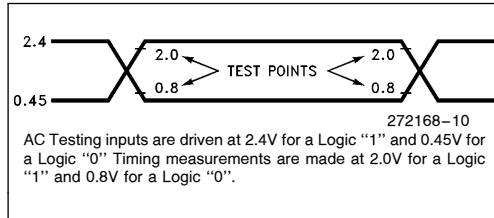

FLOAT WAVEFORMS

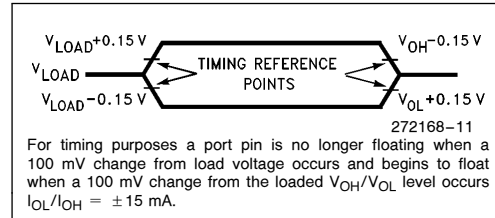

EXPLANATION OF AC SYMBOLS

Each symbol is two pairs of letters prefixed by "T" for time. The characters in a pair indicate a signal and its condition, respectively. Symbols represent the time between the two signal/condition points.

Conditions:

- H— High
- L— Low
- V— Valid
- X— No Longer Valid
- Z— Floating

Signals:

- A— Address
- B— \overline{BHE}
- C— CLKOUT
- D— DATA
- G— Buswidth
- H— \overline{HOLD}
- HA— \overline{HLDA}

L— ALE/ \overline{ADV}

- BR— \overline{BREQ}
- R— \overline{RD}
- W— $\overline{WR}/\overline{WRH}/\overline{WRL}$
- X— XTAL1
- Y— READY
- Q— Data Out

AC CHARACTERISTICS—SERIAL PORT—SHIFT REGISTER MODE

SERIAL PORT TIMING—SHIFT REGISTER MODE

Symbol	Parameter	Min	Max	Units
T_{XLXL}	Serial Port Clock Period (BRR \geq 8002H)	$6 T_{OSC}$		ns
T_{XLXH}	Serial Port Clock Falling Edge to Rising Edge (BRR \geq 8002H)	$4 T_{OSC} - 50$	$4 T_{OSC} + 50$	ns
T_{XLXL}	Serial Port Clock Period (BRR = 8001H)	$4 T_{OSC}$		ns
T_{XLXH}	Serial Port Clock Falling Edge to Rising Edge (BRR = 8001H)	$2 T_{OSC} - 50$	$2 T_{OSC} + 50$	ns
T_{QVXH}	Output Data Setup to Clock Rising Edge	$2 T_{OSC} - 50$		ns
T_{XHQX}	Output Data Hold after Clock Rising Edge	$2 T_{OSC} - 50$		ns
T_{XHQV}	Next Output Data Valid after Clock Rising Edge		$2 T_{OSC} + 50$	ns
T_{DVXH}	Input Data Setup to Clock Rising Edge	$T_{OSC} + 50$		ns
T_{XHDX}	Input Data Hold after Clock Rising Edge	0		ns
T_{XHQZ}	Last Clock Rising to Output Float		$1 T_{OSC}$	ns

WAVEFORM—SERIAL PORT—SHIFT REGISTER MODE

SERIAL PORT WAVEFORM—SHIFT REGISTER MODE

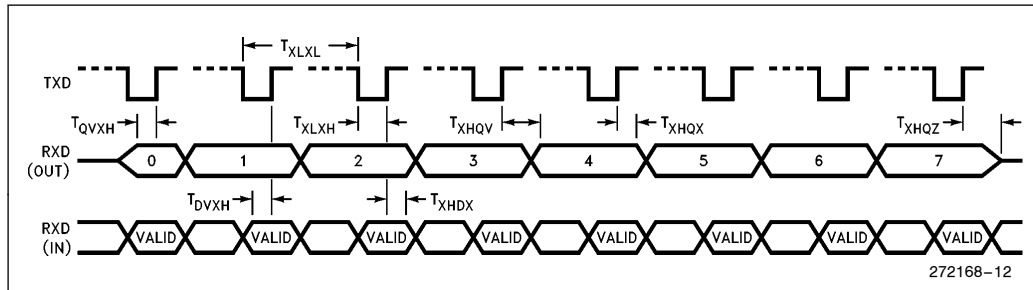

EPROM SPECIFICATIONS

AC EPROM Programming Characteristics

Operating Conditions: Load Capacitance = 150 pF, $T_A = +25^\circ\text{C} \pm 5^\circ\text{C}$, V_{CC} , $V_{REF} = 5\text{V}$, V_{SS} , $ANGND = 0\text{V}$, $V_{PP} = 12.50\text{V} \pm 0.25\text{V}$, $EA = 12.50\text{V} \pm 0.25\text{V}$

Symbol	Description	Min	Max	Units
T_{SHLL}	Reset High to First $\overline{\text{PALE}}$ Low	1100		T_{OSC}
T_{LLLH}	$\overline{\text{PALE}}$ Pulse Width	50		T_{OSC}
T_{AVLL}	Address Setup Time	0		T_{OSC}
T_{LLAX}	Address Hold Time	100		T_{OSC}
T_{PLDV}	$\overline{\text{PROG}}$ Low to Word Dump Valid		50	T_{OSC}
T_{PHDX}	Word Dump Data Hold		50	T_{OSC}
T_{DVPL}	Data Setup Time	0		T_{OSC}
T_{PLDX}	Data Hold Time	400		T_{OSC}
$T_{PLPH(2)}$	$\overline{\text{PROG}}$ Pulse Width	50		T_{OSC}
T_{PHLL}	$\overline{\text{PROG}}$ High to Next $\overline{\text{PALE}}$ Low	220		T_{OSC}
T_{LHPL}	$\overline{\text{PALE}}$ High to $\overline{\text{PROG}}$ Low	220		T_{OSC}
T_{PHPL}	$\overline{\text{PROG}}$ High to Next $\overline{\text{PROG}}$ Low	220		T_{OSC}
T_{PHIL}	$\overline{\text{PROG}}$ High to $\overline{\text{AINC}}$ Low	0		T_{OSC}
T_{ILIH}	$\overline{\text{AINC}}$ Pulse Width	240		T_{OSC}
T_{ILVH}	$\overline{\text{PVER}}$ Hold after $\overline{\text{AINC}}$ Low	50		T_{OSC}
T_{ILPL}	$\overline{\text{AINC}}$ Low to $\overline{\text{PROG}}$ Low	170		T_{OSC}
T_{PHVL}	$\overline{\text{PROG}}$ High to $\overline{\text{PVER}}$ Valid		220	T_{OSC}

NOTES:

- Run Time Programming is done with $F_{OSC} = 6.0\text{ MHz to }12.0\text{ MHz}$, $V_{REF} = 5\text{V} \pm 0.50\text{V}$, $T_A = +25^\circ\text{C to } \pm 5^\circ\text{C}$ and $V_{PP} = 12.50\text{V}$. For run-time programming over a full operating range, contact the factory.
- This specification is for the Word Dump Mode. For programming pulses, use $300 T_{OSC} + 100 \mu\text{s}$.

DC EPROM Programming Characteristics

Symbol	Description	Min	Max	Units
I_{PP}	V_{PP} Supply Current (When Programming)		100	mA

NOTE:

V_{PP} must be within 1V of V_{CC} while $V_{CC} < 4.5\text{V}$. V_{PP} must not have a low impedance path to ground of V_{SS} while $V_{CC} > 4.5\text{V}$.



EPROM PROGRAMMING WAVEFORMS

SLAVE PROGRAMMING MODE DATA PROGRAM MODE WITH SINGLE PROGRAM PULSE

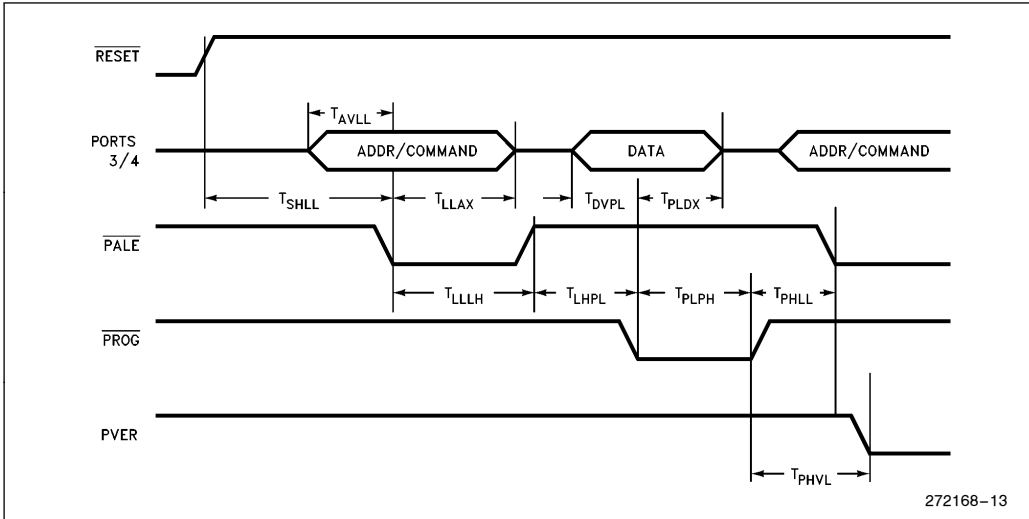

SLAVE PROGRAMMING MODE IN WORD DUMP WITH AUTO INCREMENT

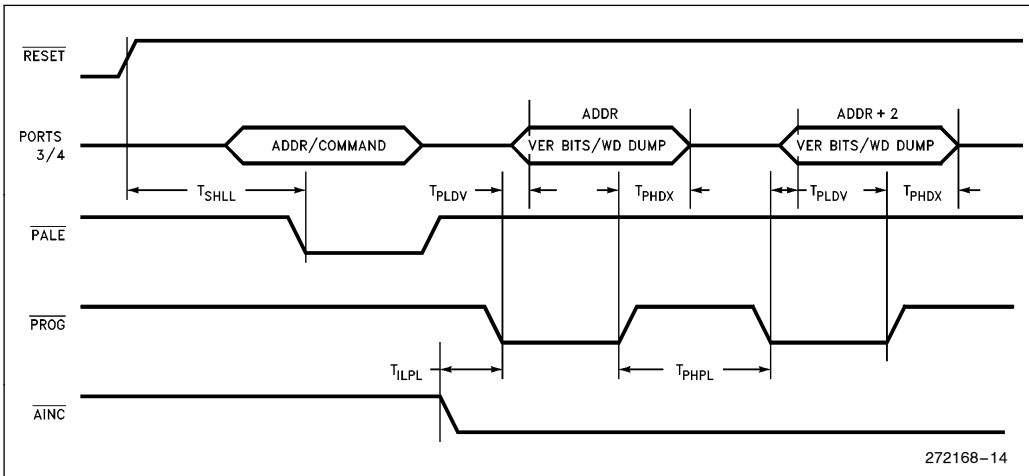

SLAVE PROGRAMMING MODE TIMING IN DATA PROGRAM WITH REPEATED PROG PULSE AND AUTO INCREMENT

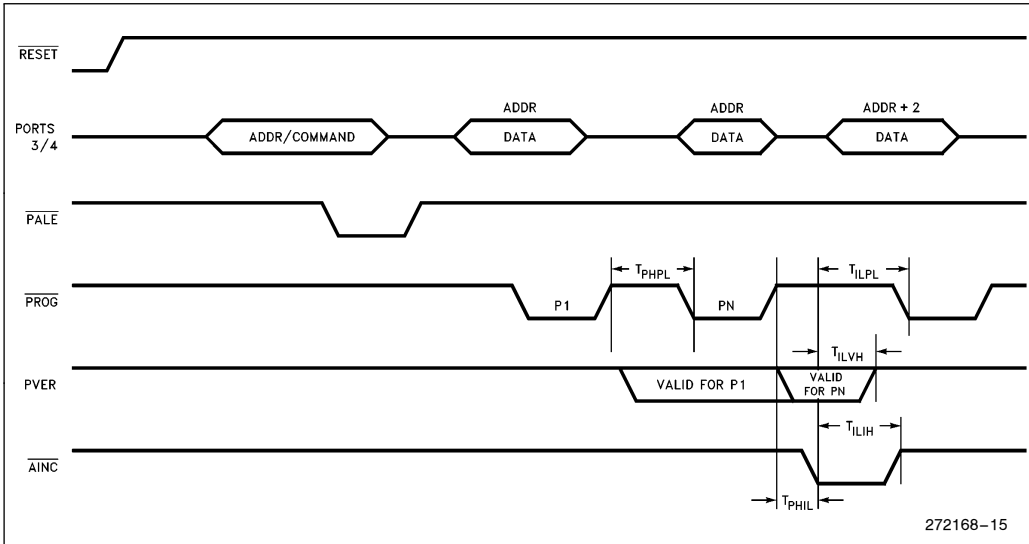

10-BIT A/D CHARACTERISTICS

The speed of the A/D converter in the 10-bit mode can be adjusted by setting a clock prescaler on or off. At high frequencies more time is needed for the comparator to settle. The maximum frequency with the clock prescaler disabled is 6 MHz. The conversion times with the prescaler turned on or off is shown in the table below. The AD_TIME register has not been characterized for the 10-bit mode.

The converter is ratiometric, so the absolute accuracy is dependent on the accuracy and stability

of V_{REF} . V_{REF} must be close to V_{CC} since it supplies both the resistor ladder and the digital section of the converter.

A/D CONVERTER SPECIFICATIONS

The specifications given below assume adherence to the Operating Conditions section of this data-sheet. Testing is performed with $V_{REF} = 5.12V$.

Clock Prescaler On IOC2.4 = 0	Clock Prescaler Off IOC2.4 = 1
156.5 States 19.5 μs @ 16 MHz	89.5 States 29.8 μs @ 6 MHz

Parameter	Typical (3)	Minimum	Maximum	Units*	Notes
Resolution		1024 10	1024 10	Levels Bits	
Absolute Error		0	± 4	LSBs	
Full Scale Error	± 3			LSBs	
Zero Offset Error	± 3			LSBs	
Non-Linearity		0	± 4	LSBs	
Differential Non-Linearity Error		> -1	+2	LSBs	
Channel-to-Channel Matching		0	± 1	LSBs	
Repeatability	± 0.25			LSBs	
Temperature Coefficients:					
Offset	0.009			LSB/°C	
Full Scale	0.009			LSB/°C	
Differential Non-Linearity	0.009			LSB/°C	
Off Isolation		-60		dB	1, 2
Feedthrough	-60			dB	1
V_{CC} Power Supply Rejection	-60			dB	1
Input Resistance		750	1.2K	Ω	
DC Input Leakage		0	3.0	μA	
Sample Time: Prescaler On	16			States	
Prescaler Off	8			States	
Input Capacitance	3			pF	

NOTES:

- *An "LSB", as used here, has a value of approximately 5 mV.
- 1. DC to 100 KHz.
- 2. Multiplexer Break-Before-Make Guaranteed.
- 3. Typical values are expected for most devices at 25°C.



8-BIT MODE A/D CHARACTERISTICS

The 8-bit mode trades off resolution for a faster conversion time. The AD_TIME register must be used when performing an 8-bit conversion.

Sample Time 20 States	Convert Time 56 States
A6H in AD_TIME 9.8 μ s @ 16 MHz	

The following specifications are tested @ 16 MHz with OA6H in AD_TIME. The actual AD_TIME register is tested with all possible values, to ensure functionality, but the accuracy of the A/D converter is not.

Parameter	Typical	Minimum	Maximum	Units*	Notes
Resolution		256 8	256 8	Levels Bits	
Absolute Error		0	± 2	LSBs	
Full Scale Error	± 1			LSBs	
Zero Offset Error	± 2			LSBs	
Non-Linearity		0	± 2	LSBs	
Differential Non-Linearity Error		> -1	$+ 1$	LSBs	
Channel-to-Channel Matching			± 1	LSBs	
Repeatability	± 0.25			LSBs	
Temperature Coefficients:					
Offset	0.003			LSB/ $^{\circ}$ C	
Full Scale	0.003			LSB/ $^{\circ}$ C	
Differential Non-Linearity	0.003			LSB/ $^{\circ}$ C	

NOTES:

*An "LSB", as used here, has a value of approximately 20 mV.

1. Typical values are expected for most devices at 25 $^{\circ}$ C.

8XC196KB TO 87C196KD DESIGN CONSIDERATIONS

1. Memory Map. The 87C196KD has 512 bytes of RAM/SFRs and 32K of ROM/EPROM. The extra 256 bytes of RAM will reside in locations 100H–1FFH and the extra 24K of EPROM will reside in locations 4000H–9FFFH. These locations are external memory on the 87C196KB.
2. The CDE pin on the KB has become a V_{SS} pin on the KC to support 16 MHz operation.
3. EPROM programming. The 87C196KD has a different programming algorithm to support 32K of on-board memory. When performing Run-Time Programming, use the section of code on page 99 of the 80C196KC User's Guide, Order Number 270704.

4. ONCE Mode Entry. The ONCE mode is entered on the 87C196KD by driving the TXD pin low on the rising edge of RESET. The TXD pin is held high by a pullup that is specified at 1.4 mA and remain at 2.0V. This Pullup must not be overridden or the 87C196KD will enter the ONCE mode.
5. During the bus HOLD state, the 87C196KD weakly holds RD, WR, ALE, BHE and INST in their inactive states. The 87C196KB only holds ALE in its inactive state.
6. A RESET pulse from the 87C196KD is 16 states rather than 4 states as on the 87C196KB (i.e., a watchdog timer overflow). This provides a longer RESET pulse for other devices in the system.





8XC196KD ERRATA

1. It is possible for the device to fail to recognize an interrupt on EXTINIT, for both P2.2 and P0.7, and NMI. The problem is most likely to occur on P0.7 while the device is operating at low voltage (<4.7V), high frequency (16 MHz) and high temperature (>85°C). There is a window of about 2 ns near clockout falling during which these interrupts may be missed.

2. In Mode 0, the serial port does not work if the highest baud rate is selected (SP_BAUD = 8001h). Data shifted into the device will not be correctly read at this baud rate.

DATASHEET REVISION HISTORY

The following are the key differences between this datasheet and the -005 version:

1. The “preliminary” status was dropped and replaced with production status (no label).
Trademarks were updated.



Looking for pricing, stock, or lifecycle information?

Click below to explore more details on WIN SOURCE:

 [View AN87C196JV20F8 on WIN SOURCE](#)

 [Intel Information](#)

Optimize Your Supply Chain with WIN SOURCE Solutions

-  Global Sourcing Solution
-  Obsolete Management
-  Cost Control Management
-  Shortage Management
-  Alternative Solution
-  Excess Inventory Management